

UNITED STATES PATENT AND TRADEMARK OFFICE

BEFORE THE PATENT TRIAL AND APPEAL BOARD

MEDTRONIC VASCULAR, INC.,
MEDTRONIC GALWAY VASCULAR UNLIMITED COMPANY,
MEDTRONIC LOGISTICS LLC, MEDTRONIC, INC.,
and MEDTRONIC USA, INC.,
Petitioners,

v.

TMT SYSTEMS, INC.,
Patent Owner

IPR2021-01532
Patent 7,101,393 B2

**PETITIONERS MEDTRONIC VASCULAR, INC., MEDTRONIC
GALWAY VASCULAR UNLIMITED COMPANY, MEDTRONIC
LOGISTICS LLC, MEDTRONIC, INC., AND MEDTRONIC USA, INC.,
INC.'S NOTICE OF APPEAL UNDER 37 C.F.R. § 90.2(a)**

Pursuant to 35 U.S.C. §§ 141-144, 319, and 37 C.F.R. § 90.2(a), notice is hereby given that Petitioners Medtronic Vascular, Inc., Medtronic Galway Vascular Unlimited Company, Medtronic Logistics LLC, Medtronic, Inc., and Medtronic USA, Inc. (collectively, “Medtronic”) appeal to the United States Court of Appeals for the Federal Circuit from the Final Written Decision (“Final Written Decision”) (Paper No. 56, dated March 7, 2023) entered by the United States Patent and Trademark Office, Patent Trial and Appeal Board (“Board”) in IPR2021-01532, and from all underlying orders, decisions, rulings, and opinions. A copy of the Final Written Decision is attached hereto as Exhibit A.

In accordance with 37 C.F.R. § 90.2(a)(3)(ii), Medtronic further indicates that the issues on appeal may include, but are not limited to, whether the Board erred in determining that claims 1, 2, 4, 10, 11, and 26 of U.S. Patent No. 7,101,393 were not shown to be unpatentable under 35 U.S.C. § 103, any findings supporting or related to the Board’s determination, and all other issues decided adversely to Medtronic in any order, decision, ruling, and/or opinion, including but not limited to the Board’s failure to properly consider evidence of record, the Board’s legal errors in undertaking the obviousness analysis, and the Board’s findings that conflict with the evidence of record and/or are not supported by substantial evidence.

Simultaneous with this submission, a copy of this Notice of Appeal is being filed through the Patent Trial and Appeal Case Tracking System (“P-TACTS”) System. In addition, a copy of the Notice of Appeal, along with the required docketing fee, is being filed with the Clerk of Court for the United States Court of Appeals for the Federal Circuit.

Dated: May 5, 2023

Respectfully submitted,

/Alexis R. Cohen/

Alexis R. Cohen

Reg. No. 76,998

Wilmer Cutler Pickering Hale and Dorr LLP

2100 Pennsylvania Avenue NW

Washington, DC 20037

(202) 663-6000

Attorney for Petitioners

CERTIFICATE OF SERVICE

I hereby certify that on this May 5, 2023, a copy of Petitioners Medtronic Vascular, Inc., Medtronic Galway Vascular Unlimited Company, Medtronic Logistics LLC, Medtronic, Inc., and Medtronic USA, Inc.’s Notice of Appeal Under 37 C.F.R. § 90.2(a) was served in its entirety by electronic mail on Patent Owner’s counsel at the following addresses included in Patent Owner’s Mandatory Notices:

Nathaniel T. Browand
NBrowand@milbank.com

Christopher J. Gaspar
CGaspar@milbank.com

Michael Scerbo
MScerbo@milbank.com

Javier J. Ramos
JRamos@milbank.com

Pursuant to 37 C.F.R. §§ 90.2(a)(1) and 104.2(a), I hereby certify that, in addition to being filed electronically through the Patent Trial and Appeal Case Tracking System (“P-TACTS”) system, a true and correct original version of the foregoing PETITIONERS’ NOTICE OF APPEAL is being filed by Express Mail on this 5th day of May, 2023, with the Director of the United States Patent and Trademark Office, at the following address:

Office of the General Counsel
United States Patent and Trademark Office
P.O. Box 1450
Alexandria, VA 22313-1450

Pursuant to 37 C.F.R. § 90.2(a)(2) and Federal Circuit Rule 15(a)(1), and Rule 52(a),(e), I hereby certify that a true and correct copy of the foregoing PETITIONERS' NOTICE OF APPEAL is being filed in the United States Court of Appeals for the Federal Circuit using the Court's CM/ECF filing system on this 5th day of May, 2023, and the filing fee is being paid electronically using pay.gov.

Dated: May 5, 2023

Respectfully submitted,
/Alexis R. Cohen/
Alexis R. Cohen
Reg. No. 76,998
Attorney for Petitioners

EXHIBIT A

UNITED STATES PATENT AND TRADEMARK OFFICE

BEFORE THE PATENT TRIAL AND APPEAL BOARD

MEDTRONIC VASCULAR, INC.,
MEDTRONIC GALWAY VASCULAR UNLIMITED COMPANY,
MEDTRONIC LOGISTICS LLC, MEDTRONIC, INC.,
and MEDTRONIC USA, INC.,
Petitioner,

v.

TMT SYSTEMS, INC.,
Patent Owner.

IPR2021-01532
Patent 7,101,393 B2

Before JAMES A. TARTAL, RYAN H. FLAX, and
CYNTHIA M. HARDMAN, *Administrative Patent Judges*.

HARDMAN, *Administrative Patent Judge*.

JUDGMENT
Final Written Decision
Determining No Challenged Claim Unpatentable
35 U.S.C. § 318(a)
Denying Patent Owner's Motion to Exclude Evidence
37 C.F.R. § 42.64

I. INTRODUCTION

This is a Final Written Decision in an *inter partes* review challenging the patentability of claims 1, 2, 4, 10, 11, and 26 of U.S. Patent No. 7,101,393 B2 (“the ’393 patent,” Ex. 1001). We have jurisdiction under 35 U.S.C. § 6.

Petitioner has the burden of proving unpatentability of the challenged claims by a preponderance of the evidence. 35 U.S.C. § 316(e). Having reviewed the parties’ arguments and cited evidence, for the reasons discussed below, we find that Petitioner has not demonstrated by a preponderance of the evidence that claims 1, 2, 4, 10, 11, and 26 are unpatentable. Additionally, for the reasons discussed below, we deny Patent Owner’s Motion to Exclude (Paper 48).

A. *Procedural History*

Medtronic Vascular, Inc., Medtronic Vascular Galway Unlimited Company, Medtronic Logistics LLC, Medtronic, Inc., and Medtronic USA, Inc. (collectively, “Petitioner”) filed a Petition requesting *inter partes* review of claims 1, 2, 4, 10, 11, and 26 of the ’393 patent. Paper 4 (“Pet.”); Paper 18 (granting Petitioner’s unopposed request to add parties to caption). Patent Owner TMT Systems, Inc. filed a Preliminary Response to the Petition. Paper 12. The parties further submitted an authorized Reply and Sur-reply to the Preliminary Response. Papers 13, 16. In view of the then-available preliminary record, we instituted an *inter partes* review. Paper 20 (“Dec.”).

After institution, Patent Owner filed a Response. Paper 34 (“PO Resp.”). Petitioner filed a Reply. Paper 37 (“Reply”). Patent Owner filed a Sur-reply. Paper 43 (“Sur-reply”).

Patent Owner filed a Motion to Exclude Evidence. Paper 48. Petitioner opposed that motion. Paper 50. Patent Owner filed a Reply. Paper 52.

On December 14, 2022, we held an oral hearing, the transcript of which is of record. Paper 55 (“Tr.”).

B. Real Parties in Interest

Petitioner identifies Medtronic Vascular, Inc., Medtronic Vascular Galway Unlimited Company, Medtronic Logistics LLC, Medtronic, Inc., and Medtronic USA, Inc. as the real parties-in-interest. Pet. 4. Patent Owner identifies TMT Systems, Inc. and Dr. Timur P. Sarac as the real parties-in-interest. Paper 7, 1; Paper 23, 1.

C. Related Matters

The parties identify a district court litigation involving the ’393 patent: *TMT Sys., Inc. et al. v. Medtronic, Inc. and Medtronic USA, Inc.*, No. 6:20-cv-00973-ADA (W.D. Tex.). Pet. 3; Paper 7, 1; Paper 23, 1. Petitioner indicates that this case “is stayed at least until the Board issues a final written decision in this proceeding.” Paper 27, 3.

The parties identify IPR2021-01533 as related to the ’393 patent. Pet. 1, 3; Paper 3 (“Petition Ranking”), 1; Paper 7, 1. We denied institution of that petition for *inter partes* review. *See Medtronic Vascular Inc. et al. v. TMT Sys. Inc.*, IPR2021-01533, Paper 20 (PTAB Mar. 22, 2022).

D. The ’393 Patent (Ex. 1001)

The ’393 patent is directed to “an endovascular apparatus having an expandable attachment device¹ for securing the endovascular apparatus to an

¹ The parties equate the term “attachment device” with “stent.” *See, e.g.*, Pet. 13; PO Resp. 11.

interior wall of a lumen.” Ex. 1001, 1:7–11. The Specification explains that the device is useful for treating aneurysms or arterial blockages, wherein the expandable attachment device is attached to an endovascular apparatus, such as a prosthetic graft, stent, or tubular sleeve. *See id.* at 1:7–2:67.

The Specification explains that “[i]n the past aortic aneurysms were treated almost exclusively by surgical repair” in which “the aneurysm would be resected and replaced by an artificial artery known as a prosthetic graft.” *Id.* at 1:25–28. “Because of the substantial risks associated with such an invasive surgery, however, other treatments for aortic aneurysms have been proposed including endovascular grafting.” *Id.* at 1:28–31. For prior endovascular grafts introduced into the patient percutaneously, the Specification indicates that “the graft must be collapsible into a small profile for negotiating the vascular system,” and “[u]pon reaching the site of the aneurysm the graft and its attachment devices can be expanded into a desired shape.” *Id.* at 1:43–47. According to the Specification, “[a] variety of expandable attachment devices have been proposed for securing an endovascular graft to an interior wall of a vessel most of which use stents with hooks or barbs to penetrate the intima of the vessel.” *Id.* at 1:48–51.

Regarding the invention, the Specification explains that “an endovascular apparatus having a new expandable attachment device is desired,” and that it “should be small with a low profile and should expand to many times its initial diameter” and “should exert enough radial force when expanded to fix into the aorta and thereby reduce blood leaks around the apparatus.” *Id.* at 1:54–60.

The ’393 patent describes such an expandable attachment device that “includ[es] a plurality of telescoping arms that are joined together to form an

expandable ring,” such that the “ring may function similarly to stents.” *Id.* at 1:66–2:2. According to the Specification, “[t]he expandable attachment device comprises a plurality of telescoping arms that are attached to form an expandable ring. Each telescoping arm is similar to an expandable presentation pointer. Alternatively, each telescoping arm may function like an accordion.” *Id.* at 2:36–40.

We reproduce below Figure 4C of the ’393 patent.

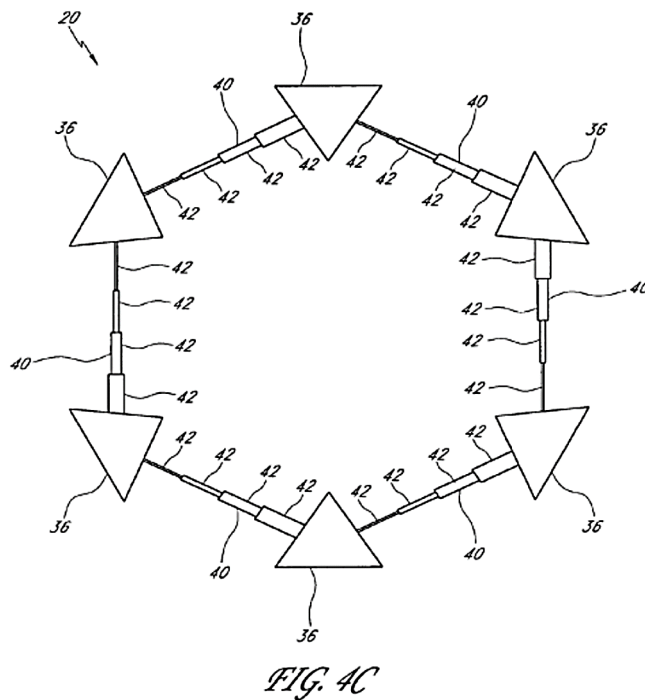

Figure 4C, reproduced above, is a top view of an expandable attachment device in a fully expanded state. *Id.* at 3:13–14. As shown in Figure 4C, expandable attachment device 20 includes a plurality of fixation components 36 positioned about its perimeter and “telescopic arm 40 is used

to attach each fixation component 36 to an adjacent fixation component 36.”² *Id.* at 5:1–5, 12–14. The Specification explains that

[t]he telescoping arm 40 may be pivotably attached to a fixation component 36 at one or both ends of the arm 40. A telescoping arm 40 is made up of a plurality of segments 42. The segments 42 may be in slideable contact with one another and may be incrementally sized so as to fit within one another. For example, each telescoping arm 40 may be constructed from what is referred to generally as “nested tubes.”

....

[T]he attachment device may take variety of shapes depending upon the configuration of the telescoping arms 40 and the fixation components 36. For example, referring to FIGS. 12A–D, the telescoping arms 40 may be positioned in a single plane. Alternatively, referring to FIGS. 13A–U, the telescoping arms 40 may be positioned in multiple planes in, for example, what is referred to herein as an “M configuration.” One possible advantage of the M configuration is that it may produce superior radial force for holding the attachment device in position. In addition, the M configuration may produce the same ratio of expansion (i.e., the ratio of the final outer diameter of the attachment device in its expanded state to the initial outer diameter of the attachment device in its collapsed state) as the “single plane configuration” using fewer parts.

Id. at 5:14–21, 31–46.

² Throughout this Decision, we omit bolding of reference numbers in quotes from the ’393 patent and prior art patents.

We reproduce below Figure 12A of the '393 patent.

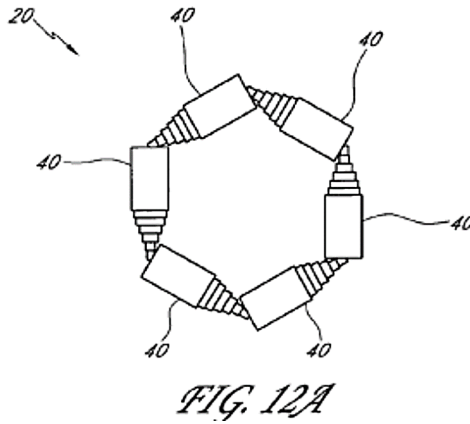
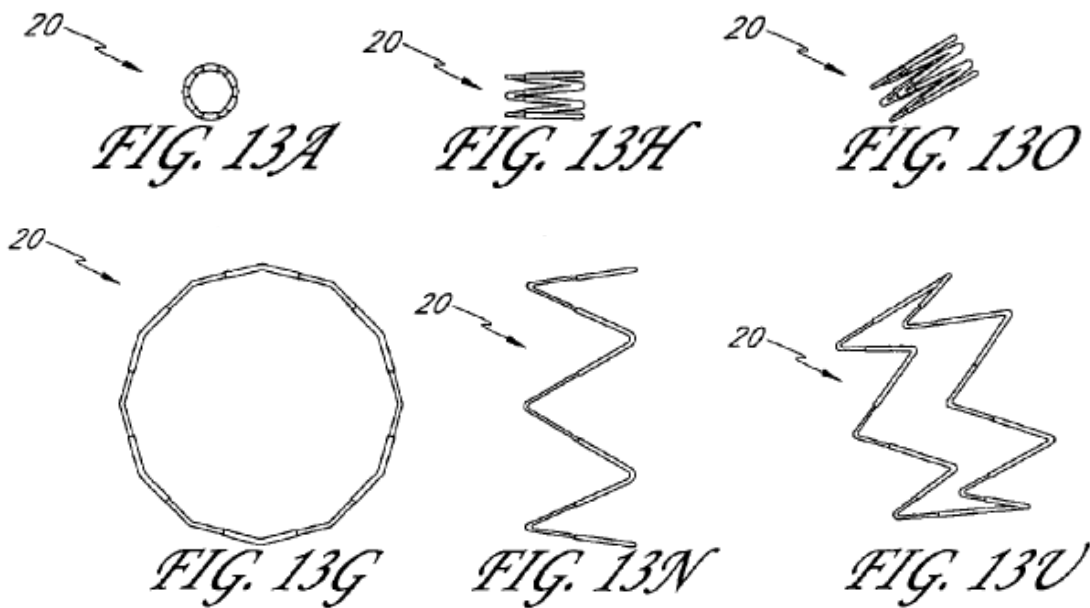

Figure 12A, reproduced above, “is a schematic top view of an expandable attachment device according to a second aspect in a partially expanded state.” *Id.* at 3:29–31. Figure 12A shows that “telescoping arms 40 may be positioned in a single plane.” *Id.* at 5:34–35.

We reproduce below Figures 13A, 13G, 13H, 13N, 13O, and 13U of the '393 patent.



Figures 13A and 13G “are schematic top views of an expandable attachment device according to a third aspect in various states of expansion.” *Id.* at 3:38–40. Figures 13H and 13N “are schematic side views of the expandable attachment device” of Figures 13A and 13G, respectively. *Id.* at 3:41–42. Figures 13O and 13U “are schematic isometric views of the expandable attachment device” of Figures 13A and 13G, respectively. *Id.* at 3:43–44. Figures 13A, 13G, 13H, 13N, 13O, and 13U show that “telescoping arms 40 may be positioned in multiple planes” in what is referred to as an “M configuration.” *Id.* at 5:36–38.

We reproduce below Figure 9 of the '393 patent.

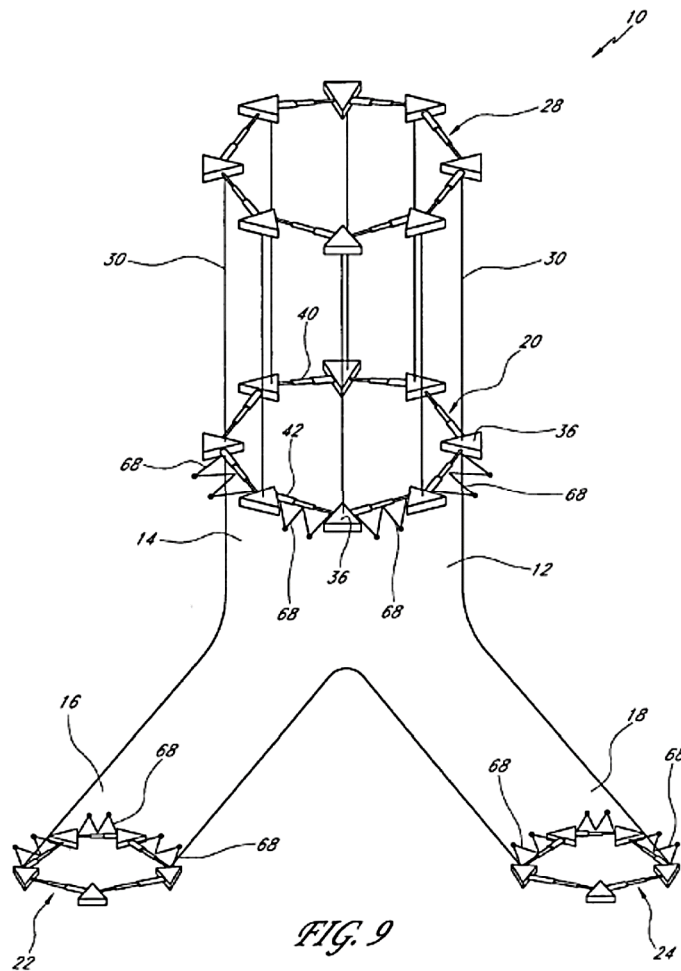

Figure 9, reproduced above, “is an endovascular apparatus according to a fourth aspect.” *Id.* at 3:23–24. Figure 9 shows a plurality of “M springs 68” that are used “as graft expanders” to “reduce leakage around the perimeter of the tubular sleeve 12.” *Id.* at 6:22–28. “In the embodiment shown in FIG. 9, the M springs 68 are not attached to the segments” of telescoping arms 40 and “are located on the exterior” of tubular sleeve 12. *Id.* at 6:30–33. The Specification further discloses that

[i]n another embodiment, the M springs 68 may be . . . attached to the fixation components 36. Of course, in place of the “M springs” 68, springs in the shape of a “V” may be used. Alternatively, in another embodiment . . . , the M springs 68 may be replaced by telescoping arms 40 in an “M configuration.”

Id. at 6:33–40.

E. The Challenged Claims

Petitioner challenges independent claims 1 and 26, along with dependent claims 2, 4, 10, and 11 of the ’393 patent. Pet. 6. Independent claim 1, reproduced below, is illustrative.

1. An attachment device that is expandable from a first state to a second state for securing an endovascular apparatus to an interior wall of a lumen, the device comprising:
 - a plurality of telescoping arms, the arms being operatively connected to one another so as to form a perimeter of variable length, wherein the telescoping arms are operatively coupled to one another at an angle so that multiple telescoping arms form the shape of a M.

Ex. 1001, 7:16–23.

F. The Asserted Unpatentability Challenges

We instituted trial based on the following three obviousness challenges:

Claim(s) Challenged	35 U.S.C. §³	Reference(s)/Basis
1, 2, 4, 11, 26	§ 103(a)	Quiachon, ⁴ Lazarus ⁵
10	§ 103(a)	Quiachon, Lazarus, Lau ⁶
1, 2, 4, 10, 11, 26	§ 103(a)	Hartley, ⁷ Lazarus

Dec. 9, 56; Pet. 6.

Petitioner support its contentions with two declarations from Elliot L. Chaikof, M.D., Ph.D. (Exs. 1003, 1072), among other evidence. Patent Owner support its contentions with a declaration from Dr. Joel Berry (Ex. 2083), among other evidence.

³ The Leahy-Smith America Invents Act (“AIA”), Pub. L. No. 112-29, 125 Stat. 284, 287–88 (2011), amended 35 U.S.C. § 103, effective March 16, 2013. Because the application from which the ’393 patent issued claims an effective filing date prior to March 16, 2013, which Petitioner does not contest, we apply the pre-AIA version of § 103. *See* Ex. 1001, Feb. 28, 2017 Certificate of Correction for ’393 patent (listing provisional patent applicated filed on July 22, 2002); *see also* Pet. 5 n.3, 17.

⁴ Quiachon et al., US 5,824,044, issued Oct. 20, 1998 (Ex. 1004, “Quiachon”).

⁵ Lazarus, US 6,165,214, issued Dec. 26, 2000 (Ex. 1006, “Lazarus”).

⁶ Lau et al., US 5,919,225, issued July 6, 1999 (Ex. 1007, “Lau”).

⁷ Hartley et al., WO 99/29262 A1, published June 17, 1999 (Ex. 1005, “Hartley”).

II. ANALYSIS

A. *Level of Ordinary Skill in the Art*

We consider Petitioner’s unpatentability challenges in view of the understanding of a person of ordinary skill in the art (sometimes referred to herein as “POSA” or “skilled artisan”) as of the claimed July 22, 2002 priority date. *See* Ex. 1001, Feb. 28, 2017 Certificate of Correction for ’393 patent (listing provisional patent applicated filed on July 22, 2002); Pet. 17; PO Resp. 9. Petitioner contends that a person of ordinary skill in the art as of this date would have been:

a medical practitioner, with experience using endovascular stent grafts and with training, experience, or familiarity applying principles of engineering to the design, development, or testing of endovascular devices; and/or an engineer having at least a bachelor of science degree and with several years of experience in the design, development, or testing of endovascular devices and their clinical use.

Pet. 22–23 (citing Ex. 1003 (Chaikof Decl.) ¶¶ 26–28). Petitioner offers that “a higher level of education could reduce the number of years of experience required.” *Id.* at 23. Petitioner also asserts that a person of ordinary skill in the art would have been “familiar with the design and operation of endovascular stent grafts and the equipment and tools required to treat a patient using an endovascular stent graft.” *Id.*

For purposes of this proceeding, Patent Owner applies Petitioner’s proposed definition of the skilled artisan. PO Resp. 12.

We adopt Petitioner’s proposed level of ordinary skill in the art because it is unopposed and is consistent with the cited prior art and the disclosure of the ’393 patent. *See Okajima v. Bourdeau*, 261 F.3d 1350,

1355 (Fed. Cir. 2001) (indicating that the prior art itself may reflect an appropriate skill level).

B. Claim Construction

In an *inter partes* review, we interpret a claim “using the same claim construction standard that would be used to construe the claim in a civil action under 35 U.S.C. 282(b).” 37 C.F.R. § 42.100(b). Under this standard, we construe the claim “in accordance with the ordinary and customary meaning of such claim as understood by one of ordinary skill in the art and the prosecution history pertaining to the patent.” *Id.*

In our Institution Decision, we preliminarily construed a number of claim terms. *See* Dec. 22–37. On the full trial record, however, we determine that no claim term needs express construction to determine whether Petitioner has carried its burden of demonstrating unpatentability of the challenged claims.⁸ *See Vivid Techs., Inc. v. Am. Sci. & Eng’g, Inc.*, 200 F.3d 795, 803 (Fed. Cir. 1999) (stating that claim terms need be construed only to the extent necessary to resolve the controversy).

⁸ We further note that both parties applied the Board’s preliminary constructions in their post-institution briefs, although Patent Owner argues that the Board should re-consider its preliminary construction of “shape of an M.” *See* PO Resp. 12–13 (“PO applies the Board’s preliminary constructions,” but urges that “the Board should re-consider its preliminary construction of ‘shape of a M’” (and related terms); Reply 10 n.4 (“For purposes of this IPR, Petitioner accepts the Board’s preliminary constructions.”). Our analysis herein would be the same even under Patent Owner’s proposed construction of “shape of an M” (and related terms).

C. Overview of Asserted Prior Art

1. Quiachon (Ex. 1004)

Quiachon “relates to an improved system and method for emplacing a prosthesis and, more particularly, to a delivery catheter and method of use for placement within a corporeal lumen of a bifurcated graft having attachment systems.” Ex. 1004 (Quiachon), 1:12–16. Quiachon discloses an “intraluminal delivery system for securing a prosthesis within or between vessels or corporeal lumens of an animal, such as a human.” *Id.* at 2:36–38.

Quiachon discloses a prosthesis comprising a y-shaped bifurcated graft having a self-expanding attachment system at each of its three orifices. *Id.* at 2:52–54. An embodiment of Quiachon’s self-expanding attachment system is depicted in Figure 17, which we reproduce below.

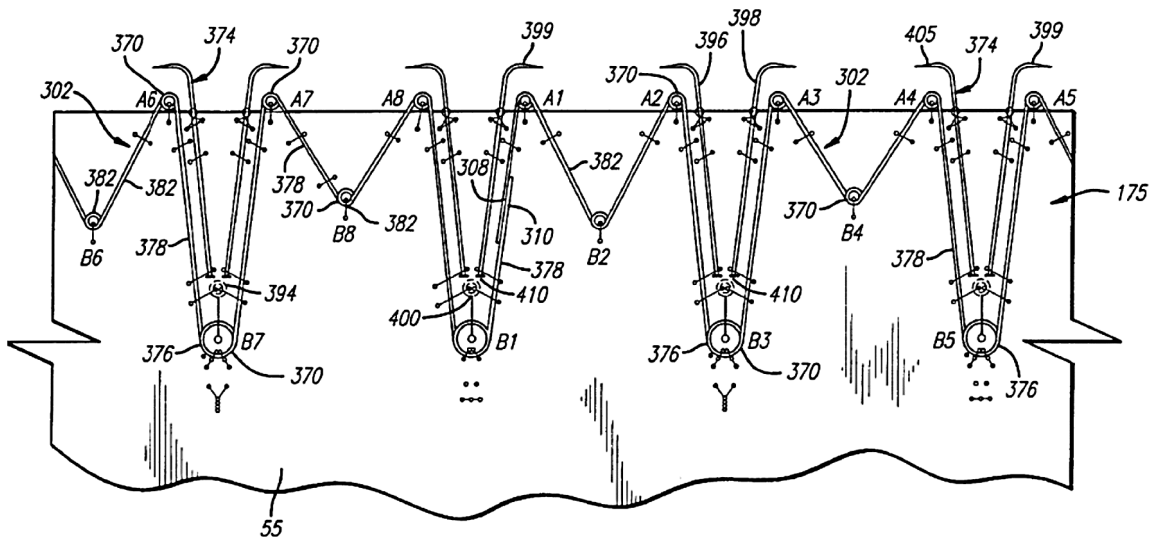

FIG. 17

- | | |
|--------------|-----------------------------------|
| → HALF KNOT | ⊗ HALF KNOT WITH WRAP AROUND |
| • ENTRY (IN) | ⋯ SINGLE KNOT |
| • EXIT (OUT) | ⋈ SUTURE BEADING (4 SQUARE KNOTS) |

Quiachon’s Figure 17, reproduced above, is a plan view of the inside of a graft cut longitudinally, showing an attachment system as sewn into the

main tubular member of the graft. *Id.* at 4:49–51. Quiachon discloses that its “attachment system [175] serves to yieldably urge” graft 55 “from a first compressed or collapsed position to a second expanded position and provides a fluid tight seal between the graft and corporeal lumen wall.”

Id. at 15:3–4, 10–14. Quiachon explains that the attachment system includes sinusoidal wire frame 302 that “is wound into helical coils or helices [370] with one and a half rotations and include[s] apices A1 through A8.” *Id.* at 15:15–16, 26–28, 49–51.

Quiachon further discloses that “the protruding apices A1 through A8 are integrally connected to adjacent base apices B1 through B8 by struts,” in which “not all of the struts are of equal length,” but “[r]ather, the length of the struts are configured to stagger the apices along different planes that are spaced longitudinally apart and are perpendicular to the axis of the graft 55.” *Id.* at 15:37–43. Quiachon states that “[i]t is an important objective of the present invention to create a narrow profile for the attachment system 175 when the attachment system is constricted radially.” *Id.* at 15:43–46.

According to Quiachon, “[s]ince the helical apices tend to have a greater radial width than the struts, staggering the apices serves the purpose of creating a narrow profile for insertion into a capsule.” *Id.* at 15:46–49. The pattern of struts “accomplishes the purpose of minimizing the radial profile of the graft in [a] collapsed position.” *Id.* at 15:54–55.

Quiachon further discloses that its attachment system also includes V-shaped lumen piercing members 374 that fit between the struts and are “adjacent to apices B1, B3, B5 and B7 in a close proximal relationship.” *Id.* at 15:64–66.

2. *Hartley (Ex. 1005)*

Hartley “relates . . . to endoluminal aortic stents and a method of deployment of such stents which allows accurate placement of a covered stent in the aorta.” Ex. 1005 (Hartley), 1:4–7. Hartley describes that its stents are “capable of being deployed and positioned accurately above the renal arteries in the treatment of infra-renal aortic aneurysmal disease.” *Id.* at 1:7–9. The “prosthesis compris[es] two or more Z stents sutured to a graft.” *Id.* at 2:21–25. The graft is compressed and placed “into a sheath which fits snugly,” and each stent is expanded “to its full extent, holding it against the aortic wall with a radial force.” *Id.* at 4:18–19, 6:3–4.

An embodiment of Hartley’s prosthesis is depicted in Figure 2, which we reproduce below.

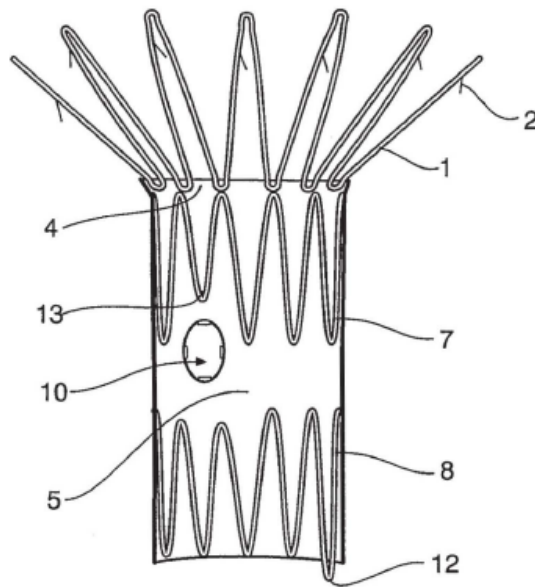

FIG 2

Hartley’s Figure 2, reproduced above, is an inside view “illustrating the internal Z stents and their relationship with the fenestrations for the intersecting arteries.” *Id.* at 5:16–18. As shown in Figure 2, two “stainless

steel or nitinol Z stents 7 and 8 are fitted within the bio-compatible material tube 5” and “[f]enestrations 10 are provided in the bio-compatible material tube 5 [for] providing a[n] aperture in the tube which will in use align with the renal or other arteries.” *Id.* at 7:13–14, 7:17–19.

3. *Lazarus (Ex. 1006)*

Lazarus “relates . . . to grafts positionable intraluminally for repairing aneurysms or other vascular defects in humans.” Ex. 1006 (Lazarus), 1:8–11. According to Lazarus, “[t]he most commonly used intraluminal graft structures have hooks or barbs which pierce into or through the wall of the vessel to anchor the graft to the vessel above the aneurysm,” and it would “be advantageous to provide an intraluminal graft structured to be flexible and adjustable to thereby facilitate insertion and placement of the graft within a vessel which displays abnormal morphology.” *Id.* at 1:53–56, 2:10–14.

An embodiment of Lazarus’ graft is depicted in Figure 7, which we reproduce below.

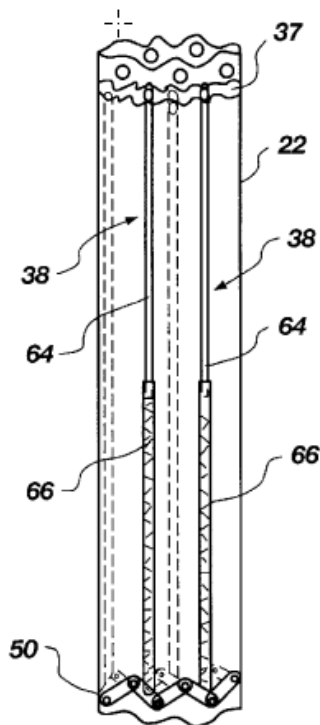

Fig. 7

Lazarus's Figure 7, reproduced above, is an elevational view of a vascular graft having longitudinal support structures 38. *Id.* at 8:9–11. The graft includes circumferential support structures such as expandable cranial ring 37 and flattened ring 50, which provide an automatic self-expanding capability. *Id.* at 9:3–6, 25–29.

Lazarus's vascular graft further includes tubular body 22 that is "adjustable with the longitudinal support structures" such as "longitudinal support structures 38 . . . comprising a first support member 64 and a second support member 66 telescopically positioned relative to each other." *Id.* at 10:31–38. Lazarus explains that "once deployed in the diseased vessel, the length of the longitudinal support structures 38 may be modified to provide an optimal fit within the vessel." *Id.* at 10:38–41.

4. *Lau (Ex. 1007)*

Lau discloses “a foldable stent or stent-graft which may percutaneously [be] delivered with (or on) a catheter, typically an endovascular catheter, to a body cavity or lumen and then expanded.”

Ex. 1007 (Lau), 1:13–16. Lau further discloses that:

a variety of materials variously metallic, super-elastic alloys, and preferably nitinol, are suitable for use in these stents. Primary requirements of the materials are that they be suitably springy even when fashioned into very thin sheets or small diameter wires. Various stainless steels which have been physically, chemically, and otherwise treated to produce high springiness are suitable as are other metal alloys such as cobalt chrome alloys (e.g., ELGILOY), platinum/tungsten alloys, various titanium alloys, and especially the nickel-titanium alloys generically known as “nitinol”).

Id. at 13:33–43.

D. *Alleged Obviousness*

Petitioner asserts three obviousness challenges: (1) claims 1, 2, 4, 11, and 26 over the combination of Quiachon and Lazarus; (2) claim 10 over the combination of Quiachon, Lazarus, and Lau; and (3) claims 1, 2, 4, 10, 11, and 26 over the combination of Hartley and Lazarus. Pet. 6. Patent Owner opposes Petitioner’s obviousness challenges. PO Resp. 26–63.

For the reasons discussed below, on this record we determine that Petitioner has not shown by a preponderance of the evidence that any challenged claim is unpatentable.

1. *Legal Standards*

Under pre-AIA § 103, a claim is unpatentable as obvious “if the differences between the subject matter sought to be patented and the prior art are such that the subject matter as a whole would have been obvious at the

time the invention was made to a person having ordinary skill in the art to which said subject matter pertains.” 35 U.S.C. § 103(a) (2012); *see also KSR Int’l Co. v. Teleflex Inc.*, 550 U.S. 398, 406 (2007). The question of obviousness is resolved based on underlying factual determinations including: (1) the scope and content of the prior art; (2) any differences between the claimed subject matter and the prior art; (3) the level of ordinary skill in the art;⁹ and (4) any objective indicia of nonobviousness.¹⁰ *Graham v. John Deere Co.*, 383 U.S. 1, 17–18 (1966). An obviousness determination requires finding “a motivation to combine accompanied by a reasonable expectation of achieving what is claimed in the patent-at-issue.” *Intelligent Bio-Sys., Inc. v. Illumina Cambridge Ltd.*, 821 F.3d 1359, 1367 (Fed. Cir. 2016).

2. *Alleged Obviousness Over Quiachon and Lazarus*

As noted above, the parties dispute whether claims 1, 2, 4, 11, and 26 are unpatentable as obvious over the combination of Quiachon and Lazarus. We first summarize Petitioner’s arguments, then analyze those arguments and Patent Owner’s responses thereto. We focus on whether Petitioner has adequately demonstrated that a person of ordinary skill in the art would have combined the teachings of Quiachon and Lazarus to achieve the claimed invention as Petitioner proposes, because this issue is dispositive of all challenged claims. *Cf. Samsung Elecs. Co., Ltd. v. Elm 3DS Innovations, LLC*, 925 F.3d 1373, 1383 (Fed. Cir. 2019) (not reaching other issues where analysis of reasonable expectation of success arguments was dispositive).

⁹ *See supra* Section II.A.

¹⁰ Patent Owner does not assert objective indicia supporting nonobviousness of the challenged claims. *See generally* PO Resp.; Reply 31 n.12.

*a) Overview of Petitioner's Obviousness Argument
Based on Quiachon and Lazarus*

Petitioner asserts that Quiachon teaches “nearly all limitations” of claims 1, 2, 4, 11, and 26, except the “telescoping arms” limitation, for which Petitioner turns to Lazarus. Reply 1. More specifically, Petitioner asserts that Quiachon’s “self-expanding superior attachment system” is “[a]n attachment device that is expandable from a first state to a second state for securing an endovascular apparatus to an interior wall of a lumen” as claimed, because it comprises “expandable rings that function like stents,” and it “serves to yieldably urge the graft 55 from a first compressed or collapsed position to a second expanded position and provides a fluid tight seal between the graft and corporeal lumen wall.” Pet. 36–37 (quoting Ex. 1004 (Quiachon), 15:3–14, 26:43–47, 29:34–37). Petitioner asserts that Quiachon’s attachment system comprises a plurality of arms (which Quiachon calls “struts”) that connect each of eight outwardly protruding apices A1–A8 to adjacent base apices B1–B8, as shown in Quiachon’s Figure 17. *Id.* at 38 (citing Ex. 1004 (Quiachon), 15:29–32, Fig. 17).

For the claimed “telescoping arms” limitation, Petitioner cites Lazarus’s disclosure of “longitudinal support structures having telescoping members.” *Id.* at 39 (citing Ex. 1006 (Lazarus), 4:7–9, 3:36–37, 4:10–20, 10:28–40, Fig. 7).

Petitioner argues that a person of ordinary skill in the art would have been motivated to combine Quiachon’s struts with Lazarus’s telescoping longitudinal support structures because both references: (a) are directed to “maximally compressing a stent and successfully expanding the stent at the site of an aneurysm for a secure fit;” and (b) disclose advantages of their

designs. *Id.* at 40 (citing Ex. 1003 (Chaikof Decl.) ¶¶ 142–153). Petitioner further asserts that a person of ordinary skill in the art would have been motivated to use Lazarus’s telescoping arms “to further improve” Quiachon’s attachment system “to yield the predictable results of having a compressible and expandable device that could hold an endovascular graft open at the site of an aneurysm,” and to “achieve the flexibility and adjustability disclosed in Lazarus.” *Id.* at 40, 41 (citing, e.g., Ex. 1003 (Chaikof Decl.) ¶¶ 146–147; Ex. 1006 (Lazarus), 2:10–14).

Petitioner asserts that a skilled artisan would have had a reasonable expectation of success in combining these features of Quiachon and Lazarus because both references are directed to endovascular stent grafts for treating aneurysms, and because the combination “would have involved simple substitution of one known element (telescoping arms) for another (non-telescoping arms) to obtain predictable results (stent compression and expansion).” *Id.* at 42–43 (citing Ex. 1003 (Chaikof Decl.) ¶¶ 143, 149–150).

Petitioner asserts that in its proposed combination, the telescoping arms are “operatively connected to one another so as to form a perimeter of variable length” as required by claim 1 because Quiachon’s struts are connected using helical coils, and the perimeter of the device changes in length as the stent radially expands. *Id.* at 43–45 (citing Ex. 1004 (Quiachon), 15:3–5, 15:10–14, 15:36–39, 15:29–35; Ex. 1003 (Chaikof Decl.) ¶¶ 154–157). Petitioner also asserts that in its proposed combination, the telescoping arms are “operatively coupled to one another at an angle so that multiple telescoping arms form the shape of a M,” given that Quiachon’s struts are coupled at an angle, as depicted in Quiachon’s figures.

Id. at 46, 48 (citing, e.g., Ex. 1004 (Quiachon), 15:29–40, Figs. 14–19; Ex. 1003 (Chaikof Decl.) ¶¶ 161–170).

b) Analysis of Motivation to Combine

Considering all of the arguments and evidence of record, we find that Petitioner has not adequately demonstrated that a person of ordinary skill in the art would have been motivated to “combine the struts of Quiachon with the telescoping longitudinal support structures of Lazarus” in the manner Petitioner proposes. Pet. 40. To provide context for our analysis, we first highlight relevant teachings from Quiachon and Lazarus.

Quiachon’s intraluminal graft includes a self-expanding attachment system comprising “expandable rings that function like stents.” Pet. 37; Ex. 1003 (Chaikof Decl. ¶ 136); Ex. 1004 (Quiachon), 2:52–54, 15:3–14. The attachment system urges the graft from a compressed state to an expanded state, “and provides a fluid tight seal between the graft and corporeal lumen wall.” Ex. 1004 (Quiachon), 15:10–14. The attachment system comprises a sinusoidal wire frame made from a single piece of wire, forming a loop that provides “a continuous spring like attachment system.” *Id.* at 15:3–5, 15:15–28. The wire frame comprises outwardly protruding apices A1–A8 and base apices B1–B8, where the protruding apices are connected to the base apices by struts of varying length. *Id.* at 15:18–21, 15:30–39. This embodiment is depicted in Petitioner’s annotated version of Quiachon’s Figure 17, reproduced below:

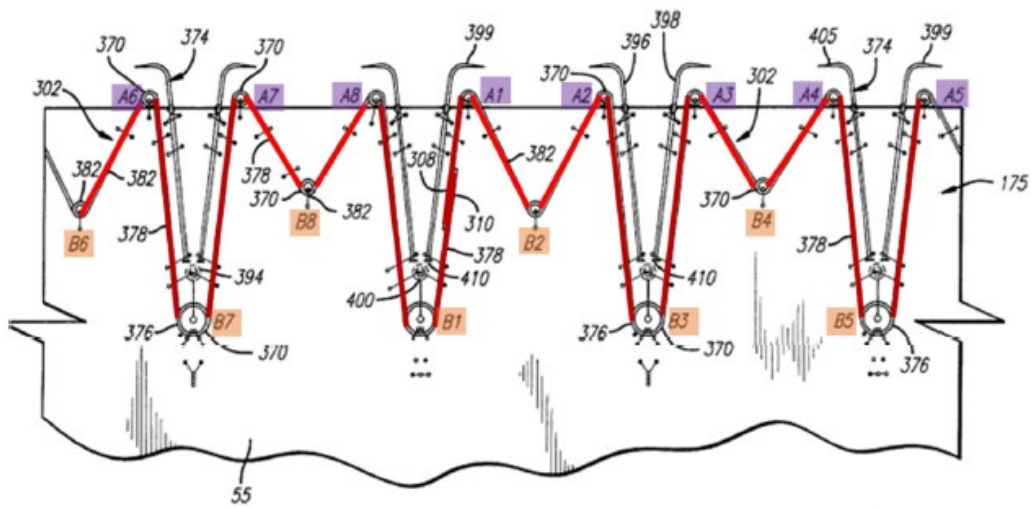

FIG. 17

- HALF KNOT
- ENTRY (IN)
- EXIT (OUT)
- ↻ HALF KNOT WITH WRAP AROUND
- SINGLE KNOT
- Y SUTURE BEADING (4 SQUARE KNOTS)

Pet. 38. In Petitioner’s annotated version of Quiachon’s Figure 17, reproduced above, the struts are colored red, the protruding apices A1–A7 are tagged in purple, and the base apices B1–B8 are tagged in orange. *Id.*

Turning to Lazarus, it teaches an intraluminal graft, as depicted in Patent Owner’s annotated version of Lazarus Figure 7, reproduced below.

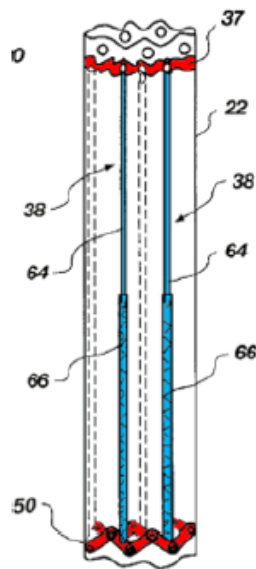

Fig. 7

Lazarus, Figure 7 (annotated).

PO Resp. 21. Patent Owner’s annotated version of Lazarus’s Figure 7, reproduced above, depicts a vascular graft having circumferential support structures at the top and bottom of the graft (colored red), and telescoping longitudinal support structures (colored blue) oriented between the circumferential support structures, along the length of the graft. *See id.* at 20–21; Ex. 2083 (Berry Decl.) ¶¶ 75–76; Ex. 1006 (Lazarus), 9:4–6 (describing circumferential support structure 37), 9:18–21 (describing circumferential support structure 50), 9:55–10:5 (describing longitudinal support structures 38).

Lazarus teaches that its longitudinal support structures “extend along the length of the tubular body 22 and support the tubular body 22 in a fully extended form when deployed,” and “serve to limit longitudinal movement of the graft.” *Id.* at 9:55–60. These structures “may be adjustable in length,” e.g., by telescoping, “to modify the length of the vascular graft.” *Id.* at 4:5–9, 10:28–30.

Lazarus teaches that its circumferential support structures “expand[] radially outward from the longitudinal axis” of the graft and attach the graft to the vessel wall. *Id.* at 8:60–9:6; *see also id.* at 9:7–43 (describing embodiments that spring open and have “automatic self-expanding capability”); 11:14–20 (“attachment of the vascular graft 20 to the inner wall of the vessel is accomplished in the present invention by expansion of the circumferential support structures against the inner vessel wall”); Ex. 2083 (Berry Decl.) ¶ 103.

Petitioner argues that a person of ordinary skill in the art would have been motivated “to form the struts in Quiachon’s attachment system out of the telescoping members disclosed in Lazarus.” Pet. 41. As Petitioner’s declarant Dr. Chaikof explains, this would “provide telescoping components between each apex” in Quiachon’s attachment system. Ex. 1003 (Chaikof Decl.) ¶ 150. Dr. Chaikof states that this modification “would merely be altering the plane in which Lazarus’s telescoping components telescope to help provide a more optimal fit in the patient’s vessel and provide a fluid tight seal.” *Id.*

As will be discussed below, we find that Petitioner has not persuasively demonstrated that a person of ordinary skill in the art would have had a reason to make the proposed modification. Rather, we agree with Patent Owner that Petitioner appears to “merely pluck[] features from different references in an attempt to construct the claimed invention.” PO Resp. 33; *see also ATD Corp. v. Lydall, Inc.*, 159 F.3d 534, 546 (Fed. Cir. 1998) (“Determination of obviousness cannot be based on the hindsight combination of components selectively culled from the prior art to fit the parameters of the patented invention.”).

To explain, we emphasize that Lazarus teaches two distinct structural components with distinct functionality, namely: (1) longitudinal support structures, which are “oriented along the length of the biocompatible graft tube” to “maintain the tube in its full, predetermined length following deployment;” and (2) circumferential support structures, which expand circumferentially and provide “attachment of the vascular graft 20 to the inner wall of the vessel.”¹¹ Ex. 1006 (Lazarus), 3:49–55, 11:14–20. Lazarus teaches that these two structures act “in tandem” to support the graft. *Id.* at 3:61–64, 8:56–59; *see also id.* at 2:22–26.

Lazarus teaches that the longitudinal support structures can telescope. *See id.* at 4:5–9. It does not teach that the circumferential support structures can telescope. *See, e.g.*, PO Resp. 42 (“There is no suggestion in Lazarus that telescoping members could be used with, or instead of, the circumferential support structures.”); Ex. 2083 (Berry Decl.) ¶ 105 (“Lazarus discloses three different embodiments of its circumferential support structures, none of which includes telescoping members.”), ¶¶ 112–16 (discussing Lazarus’s circumferential support structures and the lack of any teaching or suggestion in Lazarus to make them telescope); Ex. 2124 (Chaikof Second Tr.), 83:23–84:14 (admitting that Lazarus does not teach any telescoping circumferential support structures).

¹¹ The challenged ’393 patent also discloses two distinct structures, i.e., (1) longitudinal support columns, which may telescope, and which can be placed between expandable attachment devices to increase the length of the graft; and (2) attachment devices that expand circumferentially, which in the case of the ’393 patent, may include telescoping arms. *See, e.g.*, Ex. 1001, 4:10–26, 5:31–46; Fig. 14; PO Resp. 32.

Despite a lack of teaching in Lazarus to use telescoping functionality with the circumferential support structures, Petitioner asserts that a person of ordinary skill in the art would have modified Quiachon's continuous wire frame to impart telescoping functionality to the struts, to "further improve the known attachment system in Quiachon to yield the predictable results of having a compressible and expandable device that could hold an endovascular graft open at the site of an aneurysm." Pet. 40; *see also* Ex. 1003 (Chaikof Decl.) ¶¶ 146–47, 150. We are not persuaded.

Like Lazarus's circumferential support structures, Quiachon's wire frame expands circumferentially. *Compare, e.g.,* Ex. 1006 (Lazarus), 11:14–20 (describing circumferential support structures that expand to attach the graft to the vessel wall), *with* Ex. 1004 (Quiachon), 15:3–39 (describing self-expanding attachment system that provides a fluid tight seal between the graft and vessel wall). Thus, even if a person of ordinary skill in the art would have been motivated to incorporate Lazarus's longitudinal support structures into Quiachon's attachment system to "achieve the flexibility and adjustability disclosed in Lazarus" as Petitioner asserts (Pet. 41), we find that the specific combination Petitioner proposes to reach the claimed subject matter is not supported by the record.

More specifically, we agree with Patent Owner and credit Dr. Berry's testimony that "there is no motivation that [a] person of ordinary skill in the art would have used telescoping members of longitudinal support structures for an attachment system that expands radially or circumferentially" to hold an endovascular graft open or achieve stent compression and expansion. Ex. 2083 (Berry Decl.) ¶¶ 116, 118; *see also* PO Resp. 42–43. Petitioner does not point us to anything in Lazarus or Quiachon that teaches or

suggests operatively connecting the telescoping longitudinal support structures to form “a perimeter of variable length” or a “closed loop” as claimed. *See, e.g.*, Sur-reply 5, 7 (asserting that “none of the references suggests telescoping arms configured” as “a perimeter of variable length or a closed loop”); Ex. 2084 (Chaikof Tr.), 174:20–22 (agreeing that Lazarus’s longitudinal support structures are not in a ring shape); Ex. 2124 (Chaikof Second Tr.), 76:13–77:23 (same), 78:17–79:2 (agreeing that Lazarus does not teach connecting the longitudinal support structures in an M shape). Petitioner does not adequately explain why a person of ordinary skill in the art would have incorporated telescoping functionality into Quiachon’s wire frame, given the lack of any teaching or suggestion in Lazarus or Quiachon to use telescoping functionality in circumferentially-expanding devices like Quiachon’s wire frame.

Of course, *KSR*’s flexible motivation test does not require that the prior art expressly teach or suggest a reason that would have prompted a skilled artisan to combine the prior art in the manner proposed. *See KSR*, 550 U.S. at 418–19. “A motivation to combine may be found explicitly or implicitly in market forces; design incentives; the interrelated teachings of multiple patents; any need or problem known in the field of endeavor at the time of invention and addressed by the patent; and the background knowledge, creativity, and common sense of the person of ordinary skill.” *Realtime Data, LLC v. Iancu*, 912 F.3d 1368, 1374 (Fed. Cir. 2019) (quotations and citations omitted).

Here, Petitioner alleges that a skilled artisan would have been motivated to make the proposed combination because Quiachon and Lazarus “are directed to solving the same problem—maximally compressing a stent

and successfully expanding the stent at the site of an aneurysm for a secure fit—and both references disclose the advantages for the disclosed designs.” Pet. 40 (citing Ex. 1003 (Chaikof Decl.) ¶¶ 144–45). Petitioner also asserts that the skilled artisan would have been motivated based on “important design considerations,” including “the ability to ‘compress a stent graft into a delivery catheter,’ expand the device to ‘fit the morphology of the patient’s vasculature,’ and ‘reduce the incidence of endoleaks.’”¹² Reply 22 (citing, e.g., Ex. 1066 (Berry Tr.), 157:13–159:9; Ex. 1003 (Chaikof Decl.) ¶ 147).

We are not persuaded by Petitioner’s arguments. It is true that both Quiachon and Lazarus are directed to compressing and expanding a stent at the site of an aneurysm for a secure fit, and that both references disclose

¹² Patent Owner argues that “Petitioners improperly raise new theories and evidence in their Reply,” specifically, asserting that the devices in Quiachon and Hartley were ready for improvement due to “the known problem of endoleaks” and in view of “clear design incentives.” Sur-reply 12–13 (citing, e.g., Reply 21–22). We disagree with Patent Owner that these arguments are improper new theories. The Petition argues that a skilled artisan would have been motivated to combine Quiachon’s expandable frame with Lazarus’s telescoping arms to optimize fit. *See, e.g.*, Pet. 35, 40–41; Ex. 1003 (Chaikof Decl.) ¶ 147 (opining that Lazarus’s “telescoping arms would help to further ensure Quiachon’s superior attachment system is optimally fit to the dimensions of the blood vessel”). Although Petitioner may not have used the terms “endoleaks” or “design incentives” in the Petition, the Petition discusses using purportedly advantageous design features disclosed in Quiachon, Hartley, and Lazarus to create a secure seal, and Dr. Chaikof’s opening declaration explains that the purpose of creating a secure seal is to prevent endoleaks. *See* Pet. 35, 40–41; *see also* Ex. 1003 (Chaikof Decl.) ¶ 32. Thus, we do not view Petitioner’s Reply as improperly “proceed[ing] in a new direction with a new approach” or “rais[ing] a new issue” compared to the Petition. *See* Consolidated Trial Practice Guide (Nov. 2019), 74 (*available at* <https://www.uspto.gov/TrialPracticeGuideConsolidated>).

advantages of their designs. *See, e.g.*, Ex. 1004 (Quiachon), 15:10–14 (explaining that its self-expanding attachment system “provides a fluid tight seal between the graft and corporeal lumen wall”); Ex. 1006 (Lazarus), 2:22–26 (explaining that its circumferential and longitudinal support structures limit movement of the graft), 10:38–41 (explaining that “the length of the longitudinal support structures 38 may be modified to provide an optimal fit within the vessel”).

But Petitioner does not establish that this shared focus on securely fitting a graft teaches or suggests the specific modification Petitioner proposes to reach the claimed subject matter. As Patent Owner correctly notes, the mere fact that references “address[] the same technical issues and disclose[] closely related subject matters” is not by itself a sufficient motivation to combine. Sur-reply 8 (quoting *Microsoft Corp. v. Enfish, LLC*, 662 F. App’x 981, 990 (Fed. Cir. 2016) (nonprecedential)). Indeed, “[s]uch short-cut logic would lead to the conclusion that any and all combinations of elements known in this broad field would automatically be obvious, without the need for any further analysis.” *Securus Techs., Inc. v. Glob. Tel*Link Corp.*, 701 F. App’x 971, 977 (Fed. Cir. 2017) (nonprecedential).

Petitioner also asserts that a person of ordinary skill in the art would have been motivated to use Lazarus’s telescoping arms to “improve the known attachment system in Quiachon” and “achieve the flexibility and adjustability disclosed in Lazarus.” Pet. 40, 41 (citing Ex. 1003 (Chaikof Decl.) ¶ 147). These contentions are conclusory and unclear. *See, e.g.*, *KSR*, 550 U.S. at 418 (“[O]bviousness grounds cannot be sustained by mere conclusory statements; instead, there must be some articulated reasoning

with some rational underpinning to support the legal conclusion of obviousness.”) (quoting *In re Kahn*, 441 F.3d 977, 988 (Fed. Cir. 2006)). The Petition fails to identify exactly what is meant by “achiev[ing] the flexibility and adjustability disclosed in Lazarus.” Pet. 41.

If Petitioner means improving the *circumferential* compressibility, expandability, flexibility, and/or adjustability of Quiachon’s attachment system, Lazarus teaches that it is the circumferential support structures—not the telescoping longitudinal support structures—that provide this functionality. *See, e.g.*, Ex. 1006 (Lazarus), 3:36–48 (“The expandable circumferential support structures . . . provide[] the ability of reducing the circumferential dimension of the circumferential support structure prior to deployment, and . . . allow[] the structures to expand once the graft is deployed”), 6:51–53 (“When deployed in a vessel, the expandable circumferential support structures may spring open to expand the graft tube within the vessel.”); *see also id.* at 9:7–42 (discussing the circumferential support structures); PO Resp. 41 (“[It is the circumferential support structures of Lazarus, not its longitudinal support structures, that expand circumferentially and attach the vascular graft to the inner wall of the vessel.”); Ex. 2083 (Berry Decl.) ¶ 108 (“[A] person of ordinary skill in the art would recognize that the adjustability described in Lazarus concerns modifying the length of the vascular graft by way of the longitudinal support structures.”); Sur-reply 9 (“Lazarus teaches that compression and expansion is achieved by the distinct, circumferential support structures.”). Lazarus does not teach using telescoping members to achieve compressibility, expandability, flexibility, and/or adjustability in the *circumference* of the device.

Alternatively, if Petitioner means improving the *longitudinal* compressibility, expandability, flexibility, and/or adjustability of Quiachon's attachment system, Petitioner has not adequately explained why a person of ordinary skill in the art would have been motivated to specifically incorporate telescoping functionality into Quiachon's struts to achieve this. For example, Petitioner has not pointed us to any disclosure in Lazarus or Quiachon that teaches or suggests combining longitudinal and circumferential support structures into a single structure to achieve the adjustability in graft height provided by Lazarus's telescoping longitudinal support structures.

On Reply, Petitioner attempts to clarify the fit benefits a person of ordinary skill in the art purportedly would have been motivated to achieve. Specifically, Petitioner asserts that "Lazarus's telescoping arms provide fit benefits not only in the longitudinal direction, but also help support and anchor the graft within the vessel." Reply 20; *see also* Ex. 1072 (Chaikof Reply Decl.) ¶ 56 ("[T]he telescoping longitudinal support structures provide support to anchor the graft within the vessel in the radial direction, in addition to providing support in the longitudinal direction."). Patent Owner responds that where Lazarus teaches that the longitudinal support structures provide "optimal fit within the vessel" (Ex. 1006 (Lazarus), 10:38–40), a skilled artisan would have understood this to mean vis-à-vis the graft length, not the radial fit or seal between the graft and vessel wall. *See, e.g.*, Sur-reply 9–10.

Patent Owner has the better argument. Petitioner relies on Dr. Chaikof's testimony to support its argument that "Lazarus's telescoping arms provide fit benefits not only in the longitudinal direction, but also help

support and anchor the graft within the vessel.” Reply 20 (citing Ex. 1072 (Chaikof Reply Decl.) ¶ 56). But Dr. Chaikof’s testimony does not persuasively indicate that a person of ordinary skill in the art would have understood that Lazarus’s telescoping longitudinal support structures anchor the graft radially. First, Dr. Chaikof asserts that “Lazarus expressly discloses that its longitudinal support structures ‘facilitate insertion and placement of the graft within a vessel which displays abnormal morphology.’” *Id.* (quoting Ex. 1006 (Lazarus), 2:10–14). We disagree. The cited portion of Lazarus states general goals for an intraluminal graft; it does not specifically connect those goals to the longitudinal support structures.

Second, Dr. Chaikof quotes Lazarus’s statement that the “longitudinal support structures . . . provide means for *limiting movement of the intraluminal graft within the vessel.*” *Id.* (quoting Ex. 1006 (Lazarus), 2:22–26 (emphasis Dr. Chaikof’s)). Dr. Chaikof, however, fails to explain how this statement relates to radial support. Indeed, Lazarus later states that the longitudinal support structures “maintain the graft in place and function to keep the graft from moving back and forth *longitudinally* within the vessel.” Ex. 1006 (Lazarus), 3:64–67 (emphasis added). This suggests that the movement mentioned in Dr. Chaikof’s quote refers to longitudinal, not radial movement. Finally, Dr. Chaikof cross-references paragraphs 128 and 134 of his first declaration. *See* Ex. 1072 (Chaikof Reply Decl.) ¶ 56. Paragraph 128 does not address radial support, and paragraph 134 relates to Quiachon, not Lazarus. *See* Ex. 1003 (Chaikof Decl.) ¶¶ 128, 134. Accordingly, Dr. Chaikof has not adequately explained how these paragraphs support his opinion that a person of ordinary skill in the art

would have recognized that Lazarus's telescoping longitudinal support structures support the graft in the radial direction.¹³

Dr. Chaikof also cites Dr. Berry's testimony, wherein Dr. Berry agrees that "a person of ordinary skill in the art in 2002 would have understood that incorporating Lazarus's longitudinal support structures in place of Hartley's arms would provide anchor at the suprarenal aorta." Ex. 1066 (Berry Tr.), 203:1–9; Ex. 2083 (Berry Decl.) ¶ 182 (stating same); Ex. 1072 (Chaikof Reply Decl.) ¶ 56. Although this quotation mentions "anchor[ing]," we are not persuaded that Dr. Berry was referring to radial anchoring. Indeed, the preceding discussion at the deposition relates to the longitudinal support structures anchoring the long axis of the graft. *See* Ex. 1066 (Berry Tr.), 201:18–202:13. In view of the above, Petitioner has not persuaded us that a person of ordinary skill in the art would have been motivated to make the proposed combination to achieve fit benefits in the radial direction.

Outside of Lazarus, Petitioner asserts that "the knowledge generally available to a POSA prior to the '393 patent's filing would have motivated a POSA to form the struts in Quiachon's attachment system out of the

¹³ We observe that Lazarus teaches that "[t]he longitudinal support structures are forced radially outwardly from a central axis of the graft by force of the expandable caudal ring, and the longitudinal support structures aid in expansion of the graft." Ex. 1006 (Lazarus), 6:65–7:2. Petitioner does not appear to have cited or relied on this disclosure. Even if it had, this teaching does not support Petitioner's proffered motivation to combine. The teaching is directed to the longitudinal support structures themselves; it does not specifically implicate their (optional) telescoping functionality. *See id.* at 4:5–9 (teaching that "in an alternative embodiment," the longitudinal support structures *may* "hav[e] telescoping members").

telescoping members disclosed in Lazarus.” Pet. 41. Petitioner cites three references that purportedly disclose “attachment devices that could radially expand and contract due to telescoping members,” but details only one of these disclosures (Mueller, Ex. 1009) in the Petition. *Id.* (citing Ex. 1003 (Chaikof Decl.) ¶¶ 44–49, 148; Ex. 1009 (Mueller), 4:42–67, Fig. 9; Ex. 1038 (Yadav), Figs. 1–3; Ex. 1039 (Lentz), Fig. 4). Petitioner characterizes Mueller as “teach[ing] a stent with one section in ‘telescopic relationship’ with another section,” and asserts that “Mueller and other references further teach a POSA that telescoping arms can provide flexibility and support in an attachment device.” *Id.* at 41–42 (citing Ex. 1009 (Mueller), 4:42–67, 5:4–6; Ex. 1003 (Chaikof Decl.) ¶ 148); *see also* Ex. 1003 (Chaikof Decl.) ¶ 49 (“[I]t was well-known by 2002 that a stent could include ‘telescoping arms’ to compress and expand a stent.”); Ex. 1072 (Chaikof Reply Decl.) ¶ 59 (“[T]he examples of telescoping stent arms in the prior art would further inform a POSA that telescoping arms could provide improved expansion in the radial direction and increase flexibility and support.”).

We are not persuaded by Petitioner’s reliance on Mueller, Yadav, and/or Lentz.¹⁴ We agree with Patent Owner that Petitioner “fail[s] to

¹⁴ Patent Owner asserts that none of Mueller, Yadav, or Lentz is part of an instituted obviousness challenge and thus cannot be used “to disclose a missing claim limitation.” PO Resp. 40–41. This argument is unavailing. We do not understand Petitioner to be using these references “to disclose a missing claim limitation.” *Id.* Rather, Petitioner cites them to demonstrate “the knowledge generally available to a POSA.” Pet. 41. As such, in this case the references need not be part of the instituted grounds. *See Genzyme Therapeutic Prods. Ltd. P’ship v. Biomarin Pharm. Inc.*, 825 F.3d 1360, 1368–69 (Fed. Cir. 2016) (indicating that Board may use references to show

explain how the disclosures in these references relate to the longitudinal support structures disclosed in Lazarus or how this supposed general knowledge would have motivated a POSA to modify Quiachon's or Hartley's attachment system with the completely different telescoping longitudinal support structures disclosed in Lazarus." PO Resp. 40; *see also* Ex. 2083 (Berry Decl.) ¶ 110. Accordingly, we agree with Patent Owner that Petitioner's reliance on the knowledge in the art "lacks the 'reasoned explanation' required to support a motivation to combine." PO Resp. 40; *see also KSR*, 550 U.S. at 418.

Petitioner also argues that importing Lazarus's telescoping arms into Quiachon's attachment system "would have involved simple substitution of one known element (telescoping arms) for another (non-telescoping arms) to obtain predictable results (stent compression and expansion)." Pet. 42 (citing Ex. 1003 (Chaikof Decl.) ¶ 149). We are not persuaded. As discussed earlier in this section, neither Lazarus nor Quiachon teaches or suggests using telescoping functionality to expand and compress a stent's circumference. *See also* PO Resp. 43 ("There is no disclosure or suggestion in Quiachon, Hartley, or Lazarus to use telescoping arms that expand circumferentially to achieve stent compression and expansion."); Ex. 2083 (Berry Decl.) ¶¶ 118, 179 (stating same).

And although Petitioner cites Mueller, Yadav, and Lentz as demonstrating knowledge in the art that "a stent could include 'telescoping arms' to compress and expand a stent" (Ex. 1003 (Chaikof Decl.) ¶ 49), Petitioner has not directed us to objective evidence in the record indicating

the state of the art, even where those references are not part of the instituted prior art combination).

that a skilled artisan would have considered a plurality of telescoping arms to be a substitute for or interchangeable with the struts in Quiachon's continuous, spring-like wire frame (*see* Ex. 1004 (Quiachon), 15:16–29) in terms of circumferential expansion or achieving a tight seal. In other words, Petitioner has not demonstrated that its proposal is a mere “simple substitution.” Rather, Petitioner's proposal takes the telescoping functionality of Lazarus's longitudinal support structures and imports it into Quiachon's continuous, spring-like wire frame, which is a different structure that performs a different function. *See* Sur-reply 14 (arguing that Petitioner has not “explained why a POSA would have been motivated to use Lazarus's telescoping longitudinal support structures for a different function of ‘sealing’ Quiachon's or Hartley's attachment device to the vessel wall of a lumen”); *cf. Agrizap, Inc. v. Woodstream Corp.*, 520 F.3d 1337, 1344 (Fed. Cir. 2008) (finding claims to a pest control device obvious where they “simply substitute[d] a resistive electrical switch for the mechanical pressure switch employed by the [prior art],” and use of the resistive switch in the claimed manner “was already well known”).

For the above reasons, Petitioner has not carried its burden of proving by a preponderance of the evidence that a person of ordinary skill in the art would have combined Quiachon's struts with Lazarus's telescoping longitudinal support structures. This conclusion is consistent with our observation that Lazarus teaches using the longitudinal and circumferential support structures together in a manner that maintains their distinct structures and functions. For example, Lazarus teaches that the structures operate “in tandem” to create a frame that supports the graft. *See* Ex. 1006 (Lazarus), 3:61–64 (“The longitudinal support structures support the graft

longitudinally within the vessel and act in tandem with the expandable caudal ring to support the graft in the vessel from the distal end of the graft upward.”). Lazarus further teaches that the structures may be secured together using pivot pins 62, “in a manner which allows the longitudinal support structures 38 to articulate with and move relative to the ring 56.”¹⁵ *Id.* at 9:44–51. This arrangement is depicted in Lazarus’s Figure 6, which we reproduce below:

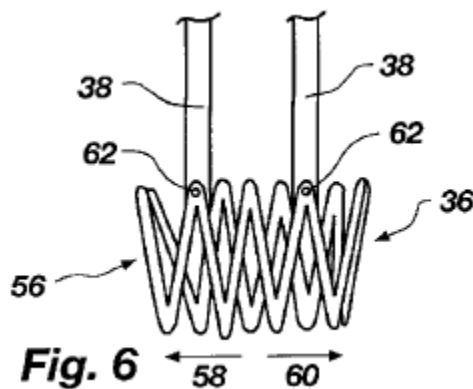

Lazarus’s Figure 6, reproduced above, shows longitudinal support structures 38 attached to circumferential support structure 56 via pivot pins 62. Thus, Lazarus teaches combining the longitudinal and circumferential support structures in a manner that maintains the separate structures of both; it does not suggest combining telescoping longitudinal support structures and circumferential support structures into a single structure, akin to Petitioner’s combination.

Finally, we observe that Dr. Chaikof’s opinion that the proposed combination “would merely be altering the plane in which Lazarus’s telescoping components telescope” is not accurate. Ex. 1003 (Chaikof

¹⁵ Ring 56 is an exemplary circumferential support structure. *See* Ex. 1006 (Lazarus), 9:18–21.

Decl.) ¶ 150. The proposed combination does not “merely . . . alter[] the plane” of Lazarus’s telescoping longitudinal support structures; it also combines them into a completely separate structure having separate functionality (Quiachon’s circumferentially-expanding wire frame). Moreover, Dr. Chaikof fails to explain why a person of ordinary skill in the art would have understood that altering the plane of Lazarus’s telescoping components would improve fit and provide a fluid tight seal. *See* 37 C.F.R. § 42.65(a) (“Expert testimony that does not disclose the underlying facts or data on which the opinion is based is entitled to little or no weight.”). The lack of articulated reasoning supporting this statement belies a hindsight bias, because it is the ’393 patent itself which teaches that the telescoping arms can be positioned in multiple planes (creating an M-shape) to produce superior radial force for holding the attachment device in position. *See* Ex. 1001, 5:36–41; Ex. 2083 (Berry Decl.) ¶ 46; *In re Ratti*, 270 F.2d 810, 813 (CCPA 1959) (reversing examiner’s obviousness rejection where “[o]nce appellant had taught how this could be done, the redesign may, by hindsight, seem to be obvious,” but “nothing in the art of record . . . suggest[ed] appellant’s novel oil seal”).

For at least the above reasons, we determine on the full trial record that Petitioner has not demonstrated by a preponderance of the evidence that “[i]t would have been obvious to combine the struts of Quiachon with the telescoping longitudinal supports structures of Lazarus.” Pet. 40.

c) Collateral Estoppel is Not Warranted

Petitioner argues that the Patent and Trademark Office (“PTO”) previously made pertinent findings during prosecution of a patent application related to the ’393 patent, and Patent Owner is collaterally

estopped from making arguments contrary to those findings. *See* Pet. 50. Patent Owner opposes. PO Resp. 64–68.

(1) *Overview of Relevant Prosecution History*

The relevant findings were made during the prosecution of U.S. Patent Application 11/484,331 (the “’331 application”), which is a continuation-in-part of the ’393 patent. *See* Pet. 18. Petitioner asserts that during prosecution of the ’331 application, Patent Owner “sought claims which included the limitations of the Challenged Claims.” *Id.*; *see also id.* at 18–19 (quoting claim limitations from the ’331 application). The examiner rejected some of those claims as obvious over Quiachon and Lazarus, finding that “it would have been obvious to make the struts [comprising the M shape] of Quiachon . . . telescoping[,] as taught by Lazarus,” “to adjust the length of the stent to better fit the patient.” *See id.* at 20, 21 (quoting Ex. 1048 (prosecution history of ’331 application), 218–19). According to Petitioner, the examiner also found this “would have been a mere combination of known elements to yield a predictable result.” *Id.* at 43 (quoting Ex. 1048 (prosecution history of ’331 application), 218–19).

Petitioner explains that Patent Owner appealed the examiner’s rejection to the Board, but during that appeal, Patent Owner did not contest the examiner’s finding “that a POSA would have been motivated to combine the teachings of Quiachon and Lazarus, such that the struts disclosed in Quiachon would telescope.” Pet. 21–22 (citing Ex. 1048 (prosecution history of ’331 application), 254). Petitioner argues: “Given that the applicant did not even contest . . . that it would have been obvious to combine the teachings of Quiachon and Lazarus, the Board did not disturb the examiner’s finding[.]” *Id.* at 22 (citing, e.g., Ex. 1004 (prosecution

history of '331 application), 338). Petitioner further asserts that “[t]he applicant did not appeal the Board’s decision.” *Id.*

Petitioner contends that following the Board decision, the examiner again rejected Patent Owner’s claims as obvious over Quiachon and Lazarus under the principles of *res judicata*, and Patent Owner ultimately canceled the claims “and did not attempt to present the claims again.” *Id.* (citing, e.g., Ex. 1004 (prosecution history of '331 application), 382).

(2) *Analysis*

“[A] party seeking to invoke collateral estoppel must show: ‘(1) the issue is identical to one decided in the first action; (2) the issue was actually litigated in the first action; (3) resolution of the issue was essential to a final judgment in the first action; and (4) [the party against whom collateral estoppel is being asserted] had a full and fair opportunity to litigate the issue in the first action.’” *Google LLC v. Hammond Dev. Int’l, Inc.*, 54 F.4th 1377, 1381 (Fed. Cir. 2022) (quoting *In re Freeman*, 30 F.3d 1459, 1465 (Fed. Cir. 1994)).

We agree with Patent Owner that Petitioner’s collateral estoppel argument fails at least because the same issues were not “actually litigated.” PO Resp. 65–66. The prosecution of the '331 application is an *ex parte* proceeding, not an adversarial proceeding such as a district court litigation or *inter partes* review. Patent Owner demonstrates that “[d]eterminations made during a prior *ex parte* prosecution do not arise from adversarial litigation.” *Id.* at 66. Rather, “there is a general consensus among courts that . . . [a] patent prosecution is not an adversarial, litigation-type proceeding, but a wholly *ex parte* proceeding before the PTO because although the process involves preparation and defense of legal claims in a

quasi-adjudicatory forum, the give-and-take of an adversary proceeding is by and large absent.” *Realvirt, LLC v. Lee*, 179 F. Supp. 3d 604, 607 (E.D. Va. 2016) (internal quotation omitted), *aff’d sub nom., Realvirt, LLC v. Iancu*, 734 F. App’x 755 (Fed. Cir. 2018); *see also id.* (stating that “PTO proceedings lack the opportunity for cross-examination, discovery, and other tools available to adversarial litigants”).

Petitioner has not cited any authority demonstrating that *ex parte* prosecution can be a basis to collaterally estop a party in a later *inter partes* review. Petitioner cites *Rimfrost AS. v. Aker Biomarine Antarctic AS.*, 2020 WL 1080516, at *9 (PTAB Mar. 6, 2020), but there, collateral estoppel was applied based on final written decisions in *inter partes* review proceedings, not based on activity in an *ex parte* prosecution. *See id.* at *10.

For at least the above reason, we agree with Patent Owner that Petitioner’s collateral estoppel argument fails.

d) Conclusion

Considering all of the arguments and evidence presented on the full trial record, we determine that Petitioner has not demonstrated by a preponderance of the evidence that claims 1, 2, 4, 11, and 26 are unpatentable as obvious over the combination of Quiachon and Lazarus.

3. *Alleged Obviousness Over Quiachon, Lazarus, and Lau*

Petitioner argues that claim 10 would have been obvious in view of Quiachon, Lazarus, and Lau. *See Pet.* 6, 61–64. For this challenge, Petitioner relies on Lau as teaching the additional limitation of dependent claim 10 (i.e., “wherein the arms are made of a nickel-titanium alloy”), but relies on the same modification of Quiachon’s struts with Lazarus’s telescoping longitudinal support structures discussed above. *See id.* at 61.

For the same reasons discussed above, we find that Petitioner has not adequately demonstrated that a person of ordinary skill in the art would have been motivated to combine Quiachon's struts with Lazarus's telescoping longitudinal support structures. *See supra* Section II.D.2(b), (c). Accordingly, we determine that Petitioner has not demonstrated by a preponderance of the evidence that claim 10 would have been unpatentable as obvious over the combination of Quiachon, Lazarus, and Lau.

4. *Alleged Obviousness Over Hartley and Lazarus*

Petitioner argues that all challenged claims (i.e., claims 1, 2, 4, 10, 11, and 26) would have been obvious over the combination of Hartley and Lazarus. *See* Pet. 6, 64–86. Petitioner asserts that Hartley teaches each limitation of the asserted claims, except the limitations directed to telescoping functionality for the claimed plurality of arms. *See* Reply 1. For the “telescoping” limitations, Petitioner turns to Lazarus. *See id.*

As discussed above in Section II.C.2, Hartley discloses “a prosthesis comprising two or more Z stents” sutured to a graft. *See* Ex. 1005 (Hartley), 2:21–25. We reproduce Petitioner's annotated version of Hartley's Figure 2 below.

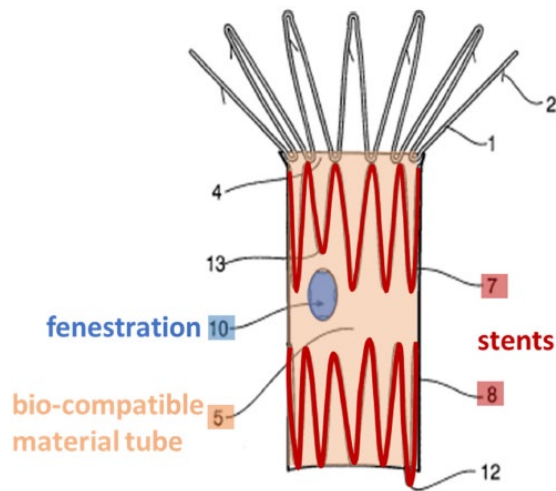

FIG 2

Pet. 67. In the annotated version of Hartley’s Figure 2 reproduced above, Petitioner colors two stents (7 and 8) in red. *See id.*; *see also* Ex. 1005 (Hartley), 7:13–14. These stents are fitted within tube 5 (colored orange), and the tube includes fenestration 10 (colored blue), which is an aperture in the tube used to align with arteries. *See* Pet. 67; *see also* Ex. 1005 (Hartley), 7:17–19. Hartley explains that each stent is compressible, and once released, it will “expand to its full extent, holding it against the aortic wall with a radial force.” Ex. 1005 (Hartley), 6:1–4; *see also* Pet. 64–65, 67 (describing Hartley’s expandable stents).

Thus, like Quiachon’s continuous wire frame, Hartley’s stents are comprised of arms operatively connected to form a compressible ring that self-expands to provide radial force against the vessel wall. *Compare, e.g.*, Ex. 1004 (Quiachon), 2:52–54, 15:3–14, *with* Ex. 1005 (Hartley), 6:1–4. In the same manner that Petitioner argues a person of ordinary skill in the art would have been motivated to combine the struts of Quiachon’s wire frame with Lazarus’s telescoping longitudinal support structures, Petitioner argues

that a person of ordinary skill in the art would have been motivated to combine “the stent arms of Hartley with the telescoping longitudinal supports structures of Lazarus.” *Compare, e.g.*, Pet. 38–43, *with id.* at, *e.g.*, 66–70; *see also* Ex. 1003 (Chaikof Decl.) ¶¶ 238–39 (discussing Hartley’s stents). Petitioner’s arguments as to why a skilled artisan would have been motivated to make this change are identical to the reasons Petitioner argued as to why a skilled artisan would have been motivated to combine Quiachon’s struts with Lazarus’s telescoping longitudinal support structures. *Compare* Pet. 40–42 (regarding the Quiachon/Lazarus combination), *with id.* at 68–70 (regarding the Hartley/Lazarus combination); *see also id.* at 35 (arguing both challenges together); Reply 17–29 (arguing the Quiachon/Lazarus and Hartley/Lazarus challenges together); Tr. 64:7–25 (in colloquy regarding differences between the Quiachon/Lazarus and Hartley/Lazarus challenges, Petitioner’s counsel stating that “fundamentally the issues are the same,” except as to (1) the claim term “shape of an M;” and (2) Patent Owner’s arguments regarding alleged problems from the proposed combination based on the location of Quiachon’s V-shaped lumen piercing members and sutures—arguments we need not and do not reach here).

We have already discussed Petitioner’s proffered reasons to combine above in connection with the Quiachon/Lazarus challenge. *See supra* Section II.D.2(b). These arguments fail with respect to the Hartley/Lazarus challenge for the same reasons discussed above. *See id.* Accordingly, we find that Petitioner has not adequately demonstrated that a person of ordinary skill in the art would have been motivated to combine Hartley’s stent arms with Lazarus’s telescoping longitudinal support structures, and

thus determine that Petitioner has not demonstrated by a preponderance of the evidence that claims 1, 2, 4, 10, 11, and 26 would have been obvious over the combination of Hartley and Lazarus.

III. PATENT OWNER'S MOTION TO EXCLUDE

Patent Owner moves to exclude Exhibits 1067, 1068, and 1071. Paper 48 (“Mot.”), 1; Paper 52 (“Reply”). Petitioner opposes. Paper 50 (“Opp.”).

Exhibits 1067 and 1071

Patent Owner argues that Petitioner filed Exhibits 1067 and 1071 with its Reply, but because neither Petitioner nor its declarant cites these exhibits, they are irrelevant and confuse the issues and should be excluded under Federal Rules of Evidence (“FRE”) 401–403. Mot. 1–2.

Petitioner responds that Exhibits 1067 and 1071 are relevant, including because Dr. Berry testified about them at his deposition, and because they do not prejudice Patent Owner. Reply 12–13; *see also id.* at 6 (citing Ex. 1066 (Berry Tr.), 53:1–75:3, 234:13–242:2).

Patent Owner, as the moving party, bears the burden of establishing that it is entitled to the requested relief. 37 C.F.R. §§ 42.20(c), 42.62(a). We determine that Patent Owner has not met its burden.

Dr. Berry testified about Exhibits 1067 and 1071 at his deposition. *See* Ex. 1066 (Berry Tr.), 53:1–75:3, 234:13–242:2. Thus, even if the exhibits are not discussed in a brief or in a declaration, we find that they give context to the deposition testimony of record. The Board is well-positioned to determine and assign appropriate weight to the presented evidence, including based on the depth of discussion of the evidence in the record. *See, e.g., Corning Inc. v. DSM IP Assets B.V.*, IPR2013-00053, Paper 66 at

19 (PTAB May 1, 2014) (“[T]he Board, sitting as a non-jury tribunal, is well-positioned to determine and assign appropriate weight to the evidence presented in this trial.”). Moreover, “there is a strong public policy for making all information filed in an administrative proceeding available to the public.” *Liberty Mut. Ins. Co. v. Progressive Cas. Ins. Co.*, CBM2012-00010, Paper 59 at 40 (PTAB Feb. 24, 2014).

In view of the above, we are unpersuaded that the probative value of Exhibits 1067 and 1071 is substantially outweighed by potential prejudice or confusion of issues. Rather than excluding these exhibits, we simply give them appropriate weight in our analysis.

Exhibit 1068

Patent Owner argues that Exhibit 1068 should be excluded under FRE 401–403, 901, and 1002. According to Patent Owner, “Petitioners cite Exhibit 1068 in their Reply and describe it as ‘Annotated Figures 13H-13N (Berry Deposition Exhibit 5.),’” but “there is no evidence or testimony as to its creation or veracity.” Mot. 2–3.

Petitioner responds that Exhibit 1068 should not be excluded because it is relevant to the issues in dispute, does not prejudice Patent Owner, and is reliable and authentic. Reply 8–10. In particular, Petitioner asserts that both Dr. Berry and Dr. Chaikof testified about the exhibit, and Dr. Chaikof cited it in his declaration and explained what it is. Reply 3 (citing Ex. 1066 (Berry Tr.), 91:5–99:4; Ex. 1072 (Chaikof Reply Decl.) ¶ 22; Ex. 2124 (Chaikof Second Tr.) 56:21–57:13, 59:21–60:1).

We determine that Patent Owner has not met its burden to exclude Exhibit 1068. As to Patent Owner’s challenges under FRE 401–403, both Dr. Berry and Dr. Chaikof testified about this exhibit. *See* Ex. 1066 (Berry

Tr.), 91:5–99:4; Ex. 1072 (Chaikof Reply Decl.) ¶ 22; Ex. 2124 (Chaikof Second Tr.), 56:21–57:13, 59:21–60:1. Thus, even if the exhibit is not discussed in a brief, we find that it gives context to the testimony of record. As noted above, the Board is well-positioned to determine and assign appropriate weight to the presented evidence, including based on the depth of discussion of the evidence in the record, and there is a strong public policy for making all information filed in an administrative proceeding available to the public. We are unpersuaded that the probative value of Exhibit 1068 is substantially outweighed by potential prejudice or confusion of issues. Rather than excluding this exhibit, we simply give it appropriate weight in our analysis.

As to Patent Owner’s argument under FRE 901, a proponent’s “burden of proof for authentication is slight.” *Lexington Ins. Co. v. W. Penn. Hosp.*, 423 F.3d 318, 328 (3d Cir. 2015). A proponent must make a showing “sufficient to support a finding that the item is what the proponent claims it is.” Fed. R. Evid. 901(a). Petitioner contends that Exhibit 1068 is an annotated version of Figures 13H–N of the ’393 patent. Opp. 1. Dr. Chaikof’s testimony supports this. He reproduces the content of Exhibit 1068 in his declaration, describing it as an “annotated version of Figures 13H to 13M” of the ’393 patent. Ex. 1072 ¶ 22. Moreover, a simple comparison of Exhibit 1068 with the figures of the ’393 patent (*see* Ex. 1001, Sheet 11) confirm that Exhibit 1068 depicts annotated versions of Figures 13H to 13M of the ’393 patent. *See* Fed. R. Evid. 901(b)(1) (stating that exhibit may be authenticated by “[a] comparison with an authenticated

specimen by . . . the trier of fact”); *Valve Corp. v. Ironburg Inventions Ltd.*, 8 F.4th 1364, 1371 (Fed. Cir. 2021).

Patent Owner asserts that the identity of the person who created the annotated figures is unknown. Mot. 2–3. This, however, is not required to authenticate the document.¹⁶ *See, e.g., Lexington Ins. Co.*, 423 F.3d at 329 (finding document authenticated even where author of handwritten notation on document remained unknown).

As to FRE 1002, Patent Owner asserts that Petitioner has not “used an original copy of the underlying document to prove its content,” and the figures in Exhibit 1068 have changes compared to those in the ’393 patent (specifically, the figures are rotated and have added colored markings and gridlines). Mot. 3. Patent Owner asserts that “[i]n the absence of testimony and cross-examination as to the Exhibit 1068’s supposed authenticity, it is not clear what other manipulations of the original may have been made to create Exhibit 1068.” *Id.*

We are not persuaded to exclude Exhibit 1068 under FRE 1002. We agree with Petitioner that the exhibit is not submitted to prove the content of Figure 13 of the ’393 patent, but is instead annotated versions of Figure 13 that provide context for Dr. Berry’s deposition testimony and Dr. Chaikof’s declaration regarding the alleged effects of telescoping the arms of the depicted attachment device. Therefore, Federal Rule of Evidence 1002 is not applicable. *See, e.g., Fed. R. Evid. 1002* (“An original writing . . . is required in order to prove its content.”).

For the above reasons, we deny Patent Owner’s motion to exclude.

¹⁶ Although not under oath, at deposition Petitioner’s counsel indicated that he created the document. *See Ex. 1066 (Berry Tr.)*, 91:12–19.

IV. CONCLUSION

Based on the information presented, we conclude that Petitioner has not demonstrated by a preponderance of the evidence that claims 1, 2, 4, 10, 11, and 26 are unpatentable. We deny Patent Owner's motion to exclude.

In summary:

Claims	35 U.S.C. §	Reference(s)/Basis	Claims Shown Unpatentable	Claims Not Shown Unpatentable
1, 2, 4, 11, 26	103	Quiachon, Lazarus		1, 2, 4, 11, 26
10	103	Quiachon, Lazarus, Lau		10
1, 2, 4, 10, 11, 26	103	Hartley, Lazarus		1, 2, 4, 10, 11, 26
Overall Outcome				1, 2, 4, 10, 11, 26

V. ORDER

In consideration of the foregoing, it is hereby:

ORDERED that Petitioner has not demonstrated by a preponderance of the evidence that claims 1, 2, 4, 10, 11, and 26 of U.S. Patent No. 7,101,393 B2 are unpatentable;

FURTHER ORDERED that Patent Owner's Motion to Exclude is *denied*; and

FURTHER ORDERED that, because this is a final written decision, parties to this proceeding seeking judicial review of our Decision must comply with the notice and service requirements of 37 C.F.R. § 90.2.

IPR2021-01532
Patent 7,101,393 B2

For PETITIONER:

David L. Cavanaugh

Alexis Cohen

Gilbert Smolenski

Jennifer Graber

WILMER CUTLER PICKERING HALE AND DORR LLP

david.cavanaugh@wilmerhale.com

alexis.cohen@wilmerhale.com

gilbert.smolenski@wilmerhale.com

jennifer.graber@wilmerhale.com

For PATENT OWNER:

Nathaniel T. Browand

Javier J. Ramos

Christopher Gaspar

MILBANK LLP

nbrowand@milbank.com

jramos@milbank.com

cgaspar@milbank.com