

UNITED STATES PATENT AND TRADEMARK OFFICE

BEFORE THE PATENT TRIAL AND APPEAL BOARD

GLOBALFOUNDRIES U.S., INC.,
GLOBALFOUNDRIES DRESDEN MODULE ONE LLC & CO. KG,
GLOBALFOUNDRIES DRESDEN MODULE TWO LLC & CO. KG,
and THE GILLETTE COMPANY,

Petitioners

v.

ZOND, LLC,
Patent Owner

Case No. IPR2014-01086¹
Patent 7,147,759 B2

PATENT OWNER'S NOTICE OF APPEAL
35 U.S.C. § 142 & 37 C.F.R. § 90.2

¹ Case IPR2014-00981 has been joined with the instant proceeding.

Pursuant to 37 C.F.R. § 90.2(a), Patent Owner, Zond, LLC, hereby provides notice of its appeal to the United States Court of Appeals for the Federal Circuit for review of the Final Written Decision of the United States Patent and Trademark Office (“USPTO”) Patent Trial and Appeals Board (“PTAB”) in *Inter Partes* Review 2014-00781, concerning U.S. Patent 7,147,759 (“the ’759 patent”), entered on August 14, 2015, attached hereto as Appendix A.

ISSUES TO BE ADDRESSED ON APPEAL

- A. Whether the PTAB erred when construing, according to its broadest reasonable interpretation in light of the specification of the ’759 patent as understood by one of ordinary skill in the art at the time of the invention, the term “without forming an arc discharge,” as recited in the claims of the ’759 patent, as “substantially eliminating the possibility of arcing?”
- B. Whether the PTAB erred in concluding that D.V. Mozgrin, *High-Current Low-Pressure Quasi-Stationary Discharge in a Magnetic Field: Experimental Research*, Thesis at Moscow Engineering Physics Institute (1994) (the “Mozgrin Thesis”) qualifies as a prior art “printed publication” under 35 U.S.C. § 102(b)?
- C. Whether the PTAB erred in finding claims 1, 4, 10, and 12 unpatentable as being obvious under 35 U.S.C. § 103(a) in view of U.S. Pat. 6,413,382

- to Wang (“Wang”) and A. A. Kudryavtsev and V.N. Skrebov, *Ionization Relaxation in a Plasma Produced by a Pulsed Inert-Gas Discharge*, 28(1) SOV. PHYS. TECH. PHYS. 30–35 (1983) (“Kudryavtsev”)?
- D. Whether the PTAB erred in finding claim 11 unpatentable as being obvious under 35 U.S.C. § 103(a) in view of Wang, Kudryavtsev and Li et al., *Low-Temperature Magnetron Sputter-Deposition, Hardness, and Electrical Resistivity of Amorphous and Crystalline Alumina Thin Films*, 18 J. VAC. SCI. TECH. A 2333–38 (2000) (“Li”)?
- E. Whether the PTAB erred in finding claim 17 unpatentable as being obvious under 35 U.S.C. § 103(a) in view of Wang, Kudryavtsev and U.S. Pat. 5,247,531 to Müller-Horsche (“Müller-Horsche”)?
- F. Whether the PTAB erred in finding claim 18 unpatentable as being obvious under 35 U.S.C. § 103(a) in view of Wang, Kudryavtsev and U.S. Pat. 5,968,327 to Kobayashi (“Kobayashi”)?
- G. Whether the PTAB erred in finding claim 44 unpatentable as being obvious under 35 U.S.C. § 103(a) in view of Wang, Kudryavtsev and the Mozgrin Thesis?

Simultaneous with submission of this Notice of Appeal to the Director of the

United States Patent and Trademark Office, this Notice of Appeal is being filed with the Patent Trial and Appeal Board. In addition, this Notice of Appeal, along with the required docketing fees, is being filed with the United States Court of Appeals for the Federal Circuit.

Respectfully submitted,

Dated: October 12, 2015

/Tarek N. Fahmi/

Tarek N. Fahmi, Reg. No. 41,402

ASCENDA LAW GROUP, PC
333 W. San Carlos St., Suite 200
San Jose, CA 95110
Tel: 866-877-4883
Email: tarek.fahmi@ascendalaw.com

APPENDIX A

UNITED STATES PATENT AND TRADEMARK OFFICE

BEFORE THE PATENT TRIAL AND APPEAL BOARD

GLOBALFOUNDRIES U.S., INC.,
GLOBALFOUNDRIES DRESDEN MODULE ONE LLC & CO. KG,
GLOBALFOUNDRIES DRESDEN MODULE TWO LLC & CO. KG, and
THE GILLETTE COMPANY,
Petitioner,

v.

ZOND, LLC,
Patent Owner.

Case IPR2014-01086¹
Patent 7,147,759 B2

Before KEVIN F. TURNER, DEBRA K. STEPHENS, JONI Y. CHANG,
SUSAN L.C. MITCHELL, and JENNIFER MEYER CHAGNON,
Administrative Patent Judges.

Opinion for the Board filed by *Administrative Patent Judge Chang.*

Opinion Dissenting-in-Part filed by *Administrative Patent Judge Stephens.*

CHANG, *Administrative Patent Judge.*

FINAL WRITTEN DECISION
Inter Partes Review
35 U.S.C. § 318(a) and 37 C.F.R. § 42.73

¹ Case IPR2014-00981 has been joined with the instant *inter partes* review.

I. INTRODUCTION

GLOBALFOUNDRIES U.S., Inc., GLOBALFOUNDRIES Dresden Module One LLC & Co. KG, and GLOBALFOUNDRIES Dresden Module Two LLC & Co. KG (collectively, “the GlobalFoundries entities”) filed a Petition requesting an *inter partes* review of claims 1, 4, 10–12, 17, 18, and 44 of U.S. Patent No. 7,147,759 B2 (Ex. 1001, “the ’759 patent”). Paper 2 (“Pet.”). Patent Owner Zond, LLC (“Zond”) filed a Preliminary Response. Paper 8 (“Prelim. Resp.”). Upon consideration of the Petition and Preliminary Response, we instituted the instant trial on October 10, 2014, pursuant to 35 U.S.C. § 314. Paper 11 (“Dec.”).

Subsequent to institution, we granted the revised Motion for Joinder filed by The Gillette Company (“Gillette”), joining Case IPR2014-00981 with the instant trial.² Paper 14. Zond filed a Response (Paper 25 (“PO Resp.”)), and GlobalFoundries filed a Reply (Paper 28 (“Reply”)). Oral hearing³ was held on June 8, 2015, and a transcript of the hearing was entered into the record. Paper 35 (“Tr.”).

We have jurisdiction under 35 U.S.C. § 6(c). This final written decision is entered pursuant to 35 U.S.C. § 318(a) and 37 C.F.R. § 42.73. For the reasons set forth below, we determine that GlobalFoundries has shown by a preponderance of the evidence that claims 1, 4, 10–12, 17, 18, and 44 of the ’759 patent are unpatentable under 35 U.S.C. § 103(a).

² In this Decision, we refer to the GlobalFoundries entities (the original Petitioner) and Gillette as “GlobalFoundries,” for efficiency.

³ The oral arguments for this review and the following *inter partes* reviews were consolidated: IPR2014-00781, IPR2014-00782, IPR2014-00800, IPR2014-00802, IPR2014-00805, IPR2014-01083, and IPR2014-01087.

A. Related District Court Proceedings

The parties indicate that the '759 patent was asserted in *Zond, LLC v. Advanced Micro Devices, Inc.*, No.1:13-cv-11577-DPW (D. Mass.), and identify other proceedings in which Zond asserted the '759 patent. Paper 5; Ex. 1034.

B. The '759 Patent

The '759 patent relates to a high-power pulsed magnetron sputtering apparatus. Ex. 1001, Abs. At the time of the invention, sputtering was a well-known technique for depositing films on semiconductor substrates. *Id.* at 1:6–13. The '759 patent indicates that prior art magnetron sputtering systems deposit films having low uniformity and poor target utilization—the target material erodes in a non-uniform manner. *Id.* at 1:55–62. To address these problems, the '759 patent discloses that increasing the power applied between the target and anode can increase the amount of ionized gas and, therefore, increase the target utilization. *Id.* at 2:60–62. However, increasing the power also “increases the probability of establishing an undesirable electrical discharge (an electrical arc) in the process chamber.” *Id.* at 2:63–67.

According to the '759 patent, forming a weakly-ionized plasma substantially eliminates the probability of establishing a breakdown condition in the chamber when high-power pulses are applied between the cathode and anode. *Id.* at 7:17–21. Once the weakly-ionized plasma is formed, high-power pulses are applied between the cathode and anode to

generate a strongly-ionized plasma from the weakly-ionized plasma. *Id.* at 7:27–30, 7:65–66.

C. Illustrative Claim

Of the challenged claims, claim 1 is the only independent claim. Claims 4, 10, 11, 12, 17, 18, and 44 depend, directly or indirectly, from claim 1. Claim 1, reproduced below, is illustrative:

1. A magnetically enhanced sputtering source comprising:
 - a) an anode;
 - b) a cathode assembly that is positioned adjacent to the anode, the cathode assembly including a sputtering target;
 - c) an ionization source that generates a weakly-ionized plasma proximate to the anode and the cathode assembly;
 - d) a magnet that is positioned to generate a magnetic field proximate to the weakly-ionized plasma, the magnetic field substantially trapping electrons in the weakly-ionized plasma proximate to the sputtering target; and
 - e) a *power supply generating a voltage pulse* that produces an electric field between the cathode assembly and the anode, the power supply being configured to generate the voltage pulse with an amplitude and a rise time that *increases an excitation rate of ground state atoms* that are present in the weakly-ionized plasma to create a multi-step ionization process that generates a strongly-ionized plasma, which comprises ions that sputter target material, from the weakly-ionized plasma, *the multi-step ionization process comprising exciting the ground state atoms to generate excited atoms, and then ionizing the excited atoms within the weakly-ionized plasma without forming an arc discharge.*

Ex. 1001, 21:22–48 (emphases added).

D. Prior Art Relied Upon

GlobalFoundries relies upon the following prior art references:

Wang	US 6,413,382 B1	July 2, 2002	(Ex. 1005)
Müller-Horsche	US 5,247,531	Sept. 21, 1993	(Ex. 1021)
Kobayashi	US 5,968,327	Oct. 19, 1999	(Ex. 1022)

D.V. Mozgrin et al., *High-Current Low-Pressure Quasi-Stationary Discharge in a Magnetic Field: Experimental Research*, 21 PLASMA PHYSICS REPORTS 400–409 (1995) (Ex. 1003, “Mozgrin”).

A.A. Kudryavtsev and V.N. Skrebov, *Ionization Relaxation in a Plasma Produced by a Pulsed Inert-Gas Discharge*, 28(1) SOV. PHYS. TECH. PHYS. 30–35 (Jan. 1983) (Ex. 1004, “Kudryavtsev”).

D.V. Mozgrin, *High-Current Low-Pressure Quasi-Stationary Discharge in a Magnetic Field: Experimental Research*, Thesis at Moscow Engineering Physics Institute (1994) (Ex. 1018, “Mozgrin Thesis”).⁴

Quan Li et al., *Low-Temperature Magnetron Sputter-Deposition, Hardness, and Electrical Resistivity of Amorphous and Crystalline Alumina Thin Films*, 18 J. VAC. SCI. TECH. A 2333–38 (2000) (Ex. 1020, “Li”).

E. Grounds of Unpatentability

We instituted the instant trial based on the following grounds of unpatentability (Dec. 29):

Claims	Basis	References
1, 4, 10, 12	§ 103(a)	Wang and Kudryavtsev
11	§ 103(a)	Wang, Kudryavtsev, and Li

⁴ The Mozgrin Thesis is a Russian-language reference. The citations to the Mozgrin Thesis are to the certified English-language translation (Ex. 1017).

Claims	Basis	References
17	§ 103(a)	Wang, Kudryavtsev, and Müller-Horsche
18	§ 103(a)	Wang, Kudryavtsev, and Kobayashi
44	§ 103(a)	Wang, Kudryavtsev, and the Mozgrin Thesis

II. ANALYSIS

A. Claim Construction

In an *inter partes* review, claim terms in an unexpired patent are given their broadest reasonable construction in light of the specification of the patent in which they appear. 37 C.F.R. § 42.100(b); *see also In re Cuozzo Speed Techs., LLC*, No. 2014-1301, 2015 WL 2097949, at *5–8 (Fed. Cir. July 8, 2015) (“Congress implicitly approved the broadest reasonable interpretation standard in enacting the AIA,”⁵ and “the standard was properly adopted by PTO regulation.”). Significantly, claims are not interpreted in a vacuum but are part of, and read in light of, the specification. *United States v. Adams*, 383 U.S. 39, 49 (1966) (“[I]t is fundamental that claims are to be construed in the light of the specifications and both are to be read with a view to ascertaining the invention.”). Claim terms are given their ordinary and customary meaning as would be understood by one of ordinary skill in the art in the context of the entire disclosure. *In re Translogic Tech., Inc.*, 504 F.3d 1249, 1257 (Fed. Cir. 2007). An inventor may rebut that presumption by providing a definition of the term in the specification with “reasonable clarity, deliberateness, and

⁵ The Leahy-Smith America Invents Act, Pub. L. No. 112–29, 125 Stat. 284 (2011) (“AIA”).

precision.” *In re Paulsen*, 30 F.3d 1475, 1480 (Fed. Cir. 1994). In the absence of such a definition, limitations are not to be read from the specification into the claims. *In re Van Geuns*, 988 F.2d 1181, 1184 (Fed. Cir. 1993).

“multi-step ionization process”

Claim 1 recites “the *multi-step ionization process* comprising exciting the ground state atoms to generate excited atoms, and then ionizing the excited atoms within the weakly-ionized plasma without forming an arc discharge.” Ex. 1001, 21:44–48 (emphasis added). Prior to institution, the parties submitted their proposed claim constructions for the claim term “multi-step ionization process.” Pet. 18; Prelim. Resp. 19–20. In the Decision on Institution, we addressed each of the parties’ contentions, and adopted Zond’s proposed construction, in light of the Specification, as the broadest reasonable interpretation. Dec. 12–13; Ex. 1001, 9:18–36. The parties do not challenge any aspect of our claim construction as to this term. PO Resp. 11–13; Reply 1–2. Upon review of the present record, we discern no reason to change our claim construction. We, therefore, construe the claim term “multi-step ionization process” in light of the Specification as “an ionization process having at least two distinct steps.”

“weakly-ionized plasma” and “strongly-ionized plasma”

Claim 1 recites “the voltage pulse with an amplitude and a rise time that increases an excitation rate of ground state atoms that are present in the *weakly-ionized plasma* to create a multi-step ionization process that generates a *strongly-ionized plasma*.” Ex. 1001, 21:38–42 (emphases added). During the pre-trial stage of this proceeding, the parties also

submitted their constructions for the claim terms “a weakly-ionized plasma” and “a strongly-ionized plasma.” Pet. 16–17; Prelim. Resp. 17–18. In our Decision on Institution, we adopted Zond’s proposed constructions, in light of the Specification, as the broadest reasonable interpretation. Dec. 10–12; *see, e.g.*, Ex. 1001, 10:3–6 (“This rapid ionization results in a strongly-ionized plasma having a large ion density being formed in an area proximate to the cathode assembly 216.”).

Subsequent to institution, notwithstanding that neither Zond, nor its expert witness, expressly challenged our claim constructions as to these terms (PO Resp. 12; Ex. 2005 ¶ 58), Zond improperly attempts to import extraneous limitations into the claim by arguing that specific ion density ranges for these claim terms are required, in connection with the ground of unpatentability based on Wang and Kudryavtsev (PO Resp. 44–45). It is well settled that if a feature is not necessary to give meaning to a claim term, it is “extraneous” and should not be read into the claim. *Renishaw PLC v. Marposs Societa’ per Azioni*, 158 F.3d 1243, 1249 (Fed. Cir. 1998); *E.I. du Pont de Nemours & Co. v. Phillips Petroleum Co.*, 849 F.2d 1430, 1433 (Fed. Cir. 1988).

Zond does not direct us to where the Specification provides an explicit definition for these claim terms, nor can we discern one. *See Paulsen*, 30 F.3d at 1480. We also do not share Zond’s view that Dr. Uwe Kortshagen’s cross-examination testimony supports its newly proposed claim constructions, requiring specific ion density ranges. PO Resp. 44 (citing Ex. 2010, 44:13–58:12). We observe that the claim terms “weakly-ionized plasma” and “strongly-ionized plasma” are relative terms, and that Dr. Kortshagen’s cross-examination testimony merely points out that one

with ordinary skill in the art possibly could have ascertained the claim scope with reasonable certainty when reading the claims in light of the Specification. *See* Ex. 2010, 44:13–58:12.

Moreover, Zond’s newly proposed constructions that require specific ion density ranges would render at least the limitation recited in dependent claim 33 superfluous. Ex. 1001, 23:35–38 (“The method of claim 20 wherein the peak plasma density of the strongly-ionized plasma is greater than about 10^{12} cm⁻³.”). It is well settled that “claims are interpreted with an eye toward giving effect to all terms in the claim.” *Bicon Inc. v. Straumann Co.*, 441 F.3d 945, 950 (Fed. Cir. 2006); *see also Stumbo v. Eastman Outdoors, Inc.*, 508 F.3d 1358, 1362 (Fed. Cir. 2007) (denouncing claim constructions that render phrases in claims superfluous). Concomitantly, “[i]t is improper for courts to read into an independent claim a limitation explicitly set forth in another claim.” *Envtl. Designs, Ltd. v. Union Oil Co. of Cal.*, 713 F.2d 698, 699 (Fed. Cir. 1983).

For the foregoing reasons, we decline to adopt Zond’s newly proposed constructions that require specific ion density ranges. Rather, upon consideration of the parties’ explanations and supporting evidence before us, we discern no reason to change our claim constructions set forth in the Decision on Institution with respect to these claim terms, which adopted Zond’s originally proposed constructions. Dec. 12. Therefore, for purposes of this Final Written Decision, we construe, in light of the Specification, the claim term “a weakly-ionized plasma” as “a plasma with a relatively low peak density of ions,” and the claim term “a strongly-ionized plasma” as “a plasma with a relatively high peak density of ions.”

“without forming an arc discharge”

Claim 1 recites, among other things, the following limitation:

the multi-step ionization process comprising exciting the ground state atoms to generate excited atoms, and then ionizing the excited atoms within the weakly-ionized plasma *without forming an arc discharge*.

Ex. 1001, 21:43–48 (emphasis added).

As we explained previously in the Decision on Institution (Dec. 23–24), neither the Specification nor the original disclosure of the ’759 patent recites the claim term “without forming an arc discharge.” Rather, they merely disclose a process that *reduces or substantially eliminates the possibility of arcing*.

For instance, the Specification of the ’759 patent discloses:

The partially ionized gas is also referred to as a weakly-ionized plasma or a pre-ionized plasma. As described herein, the formation of weakly-ionized plasma *substantially eliminates the possibility of* creating a breakdown condition when high-power pulses are applied to the weakly-ionized plasma. The suppression of this breakdown condition *substantially eliminates the occurrence of undesirable arcing* in the chamber 202.

Id. at 11:54–64 (emphases added).

As previously discussed, the weakly-ionized or pre-ionized plasma *reduces or substantially eliminates the possibility of establishing a breakdown condition* in the chamber 202 when high-power pulses are applied to the plasma.

Id. at 15:49–53 (emphasis added).

In its Responses, Zond argues that the claim term “without forming an arc discharge,” should not be construed as “reduces or substantially eliminates the possibility of arcing.” PO Resp. 22, 46–47. Zond alleges that

such a construction would not be consistent with the plain and ordinary meaning of the word “without,” essentially urging that the claim term be construed as *absolutely no arcing*. *Id.* Zond also alleges that the disputed term cannot mean a mere reduction in the number of arc discharges. *Id.*

Although Zond proffers examples of a young boy ordering ice cream without sprinkles and a customer ordering a hamburger without cheese (*id.* at 46–47), Zond does not explain adequately why *one with ordinary skill in the plasma art* would have interpreted the claim term “without forming an arc discharge,” *in light of the Specification*, to require the ionization of excited atoms be performed *completely* free of arcing. *See In re NTP, Inc.*, 654 F.3d 1279, 1288 (Fed. Cir. 2011) (stating that the Board’s claim construction “cannot be divorced from the specification and the record evidence”); *see also In re Cortright*, 165 F.3d 1353, 1358 (Fed. Cir. 1999) (stating that the Board’s claim construction “must be consistent with the one that those skilled in the art would reach”). Nor does Zond direct our attention to credible evidence that would support its attorney’s arguments regarding the disputed claim term at issue. *See* PO Resp. 46–47.

One with ordinary skill in the art would have recognized that, unlike ice cream sprinkles or cheese that can be avoided altogether simply by not adding them, electrical arcing in a real-world plasma sputtering apparatus occurs naturally under certain processing conditions. Dr. Lawrence J. Overzet testifies that “I expect that arcing will not be wholly eliminated in sputtering systems and arc-arrestor circuitry in the power supplies will continue to be required,” and that “[t]here are multiple reasons why arcing may occur, and while the multi-step ionization process disclosed in the ’759 patent may reduce or substantially eliminate the possibility of arcing, arcing

may still occur during certain instances.” Ex. 1036 ¶¶ 31, 70–71. We credit that the testimony of Dr. Overzet as it is consistent with the Specification of the ’759 patent. Ex. 1001, 11:54–64, 15:49–53.

It is well settled that “[a] claim construction that excludes the preferred embodiment is rarely, if ever, correct and would require highly persuasive evidentiary support.” *Adams Respiratory Therapeutics, Inc. v. Perrigo Co.*, 616 F.3d 1283, 1290 (Fed. Cir. 2010). A construction that excludes all disclosed embodiments, as urged by Zond here, is especially disfavored. *MBO Labs., Inc. v. Becton, Dickinson & Co.*, 474 F.3d 1323, 1333 (Fed. Cir. 2007). In short, claim construction requires claim terms to be read so that they encompass the very preferred embodiment they describe, i.e., formation of a weakly-ionized or pre-ionized plasma in a multi-step ionization process. *See On-Line Techs., Inc. v. Bodenseewerk Perkin-Elmer*, 386 F.3d 1133, 1138 (Fed. Cir. 2004).

Here, nothing in the Specification indicates that no arcing occurs when the excited atoms are ionized within the weakly-ionized plasma. Rather, it explicitly states that “the formation of weakly-ionized plasma *substantially eliminates* the possibility of creating a breakdown condition when high-power pulses are applied to the weakly-ionized plasma,” and “the suppression of this breakdown condition *substantially eliminates* the occurrence of undesirable arcing in the chamber.” Ex. 1001, 11:58–63 (emphases added). Given the disclosure in the Specification, we decline to adopt Zond’s proposed construction—absolutely no arcing—because it would be unreasonable to exclude the disclosed embodiments. *See Phillips v. AWH Corp.*, 415 F.3d 1303, 1315 (Fed. Cir. 2005) (en banc) (stating that the Specification is “the single best guide to the meaning of a disputed

term”). Instead, we construe the claim term “without forming an arc discharge” as “substantially eliminating the possibility of arcing,” consistent with an interpretation that one of ordinary skill in the art would reach when reading the claim term in the context of the Specification.

B. Principles of Law

A patent claim is unpatentable under 35 U.S.C. § 103(a) if the differences between the claimed subject matter and the prior art are such that the subject matter, as a whole, would have been obvious at the time the invention was made to a person having ordinary skill in the art to which said subject matter pertains. *KSR Int’l Co. v. Teleflex Inc.*, 550 U.S. 398, 406 (2007). The question of obviousness is resolved on the basis of underlying factual determinations including: (1) the scope and content of the prior art; (2) any differences between the claimed subject matter and the prior art; (3) the level of ordinary skill in the art; and (4) objective evidence of nonobviousness. *Graham v. John Deere Co.*, 383 U.S. 1, 17–18 (1966). In that regard, an obviousness analysis “need not seek out precise teachings directed to the specific subject matter of the challenged claim, for a court can take account of the inferences and creative steps that a person of ordinary skill in the art would employ.” *KSR*, 550 U.S. at 418; *Translogic*, 504 F.3d at 1259. The level of ordinary skill in the art is reflected by the prior art of record. See *Okajima v. Bourdeau*, 261 F.3d 1350, 1355 (Fed. Cir. 2001); *In re GPAC Inc.*, 57 F.3d 1573, 1579 (Fed. Cir. 1995); *In re Oelrich*, 579 F.2d 86, 91 (CCPA 1978).

We analyze the asserted grounds of unpatentability in accordance with the above-stated principles.

C. Claims 1, 4, 10, and 12—Obviousness over the Combination of Wang and Kudryavtsev

GlobalFoundries asserts that claims 1, 4, 10, and 12 are unpatentable under 35 U.S.C. § 103(a) as obvious over the combination of Wang and Kudryavtsev. Pet. 41–53. In its Petition, GlobalFoundries explains how the combination of the prior art technical disclosures collectively meets each claim limitation and articulates a rationale to combining the teachings. *Id.* GlobalFoundries also submitted a Declaration of Dr. Kortshagen (Ex. 1002) to support its Petition, and a Declaration of Dr. Overzet (Ex. 1036) to support its Reply to Zond’s Patent Owner Response.

Zond responds that the combination of Wang and Kudryavtsev does not disclose every claim element. PO Resp. 34–51. Zond also argues that there is insufficient reason to combine the technical disclosures of Wang and Kudryavtsev. *Id.* at 22–34. To support its contentions, Zond proffers a Declaration of Dr. Larry D. Hartsough (Ex. 2005).

We have reviewed the entire record before us, including the parties’ explanations and supporting evidence presented during this trial. We begin our discussion with a brief summary of Wang and Kudryavtsev, and then we address the parties’ contentions in turn.

Wang

Wang discloses a power pulsed magnetron sputtering apparatus for generating a very high plasma density. Ex. 1005, Abs. Wang also discloses

a sputtering method for depositing metal layers onto advanced semiconductor integrated circuit structures. *Id.* at 1:4–15.

Figure 1 of Wang, reproduced below, illustrates a magnetron sputtering system:

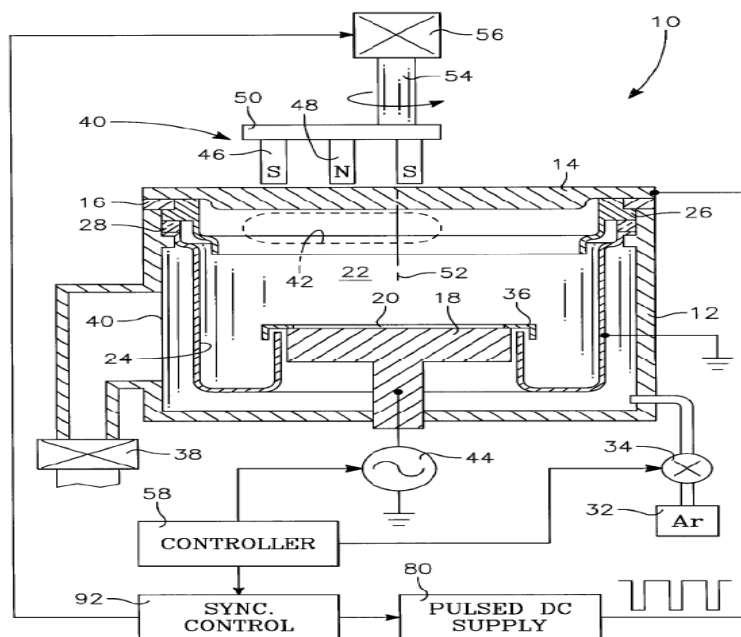

FIG. 1

As shown in Figure 1 of Wang, magnetron sputtering apparatus 10 includes anode 24, cathode 14, magnet assembly 40, and pulsed DC power supply 80, as well as pedestal 18 for supporting semiconductor substrate 20. *Id.* at 3:57–4:55. According to Wang, the apparatus is capable of creating high density plasma in region 42, which ionizes a substantial fraction of the sputtered particles into positively charged metal ions and also increases the sputtering rate. *Id.* at 4:13–34. Magnet assembly 40 creates a magnetic field near target 14, which traps electrons from the plasma to increase the electron density. *Id.* at 4:23–27. Wang further recognizes that, if a large portion of the sputtered particles are ionized, the films are deposited more uniformly and effectively—the sputtered ions can be accelerated towards a negatively

charged substrate, coating the bottom and sides of holes that are narrow and deep. *Id.* at 1:24–29.

Figure 6 of Wang, reproduced below, illustrates how the apparatus applies a pulsed power to the plasma:

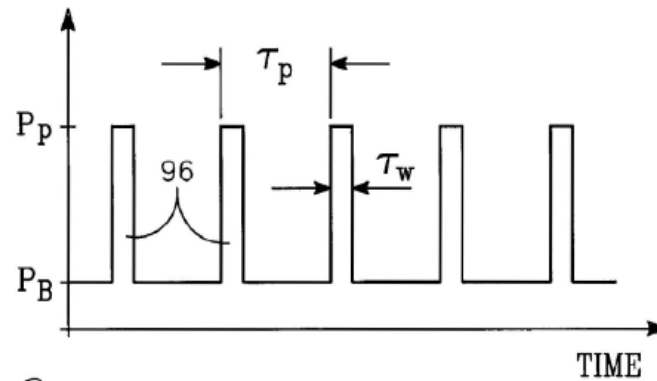
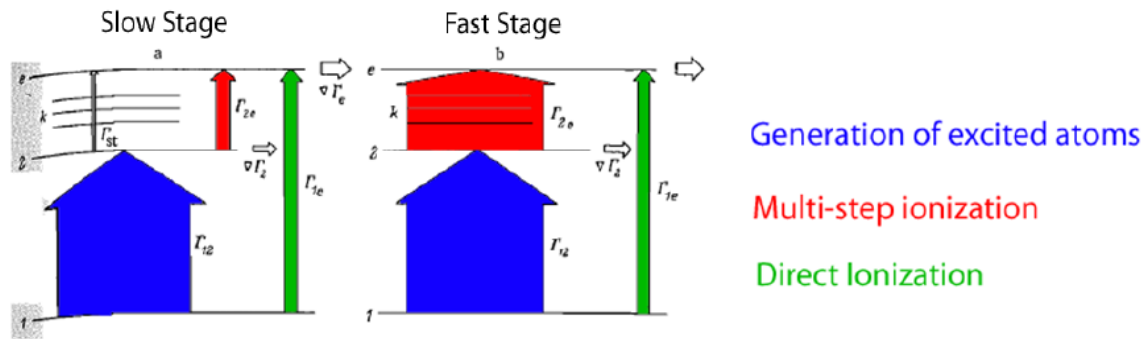

FIG. 6

As shown in Figure 6 of Wang, the target is maintained at background power level P_B between high power pulses 96 with peak power level P_P . *Id.* at 7:13–39. Background power level P_B exceeds the minimum power necessary to support a plasma in the chamber at the operational pressure (e.g., 1 kW). *Id.* Peak power P_P is at least 10 times (preferably 100 or 1000 times) background power level P_B . *Id.* The application of high peak power P_P causes the existing plasma to spread quickly, and increases the density of the plasma. *Id.* According to Dr. Kortshagen, Wang's apparatus generates a low-density (weakly-ionized) plasma during the application of background power P_B , and a high-density plasma during the application of peak power P_P . Ex. 1002 ¶¶ 127, 136–137.

Kudryavtsev

Kudryavtsev discloses a multi-step ionization plasma process, exciting the ground state atoms to generate excited atoms, and then ionizing the excited atoms. Ex. 1004, Abs., Figs. 1, 6. Figure 1 of Kudryavtsev, reproduced below (with annotations added by GlobalFoundries (Pet. 27)), illustrates the atomic energy levels during the slow and fast stages of ionization:



As shown in annotated Figure 1 of Kudryavtsev, ionization occurs with a “slow stage” (Fig. 1a) followed by a “fast stage” (Fig. 1b). During the initial slow stage, direct ionization provides a significant contribution to the generation of plasma ions (arrow Γ_{1e} showing ionization (top line labeled “e”) from the ground state (bottom line labeled “1”)). Dr. Kortshagen explains that Kudryavtsev shows the rapid increase in ionization once multi-step ionization becomes the dominant process. Ex. 1002 ¶ 81.

Indeed, Kudryavtsev discloses:

For nearly stationary n_2 [excited atom density] values . . . *there is an explosive increase in n_e [plasma density].* The subsequent increase in n_e then reaches its maximum value, equal to the rate of excitation . . . which is several orders of magnitude greater than the ionization rate during the initial stage.

Ex. 1004, 31 (emphasis added). Kudryavtsev also recognizes that “in a pulsed inert-gas discharge plasma at moderate pressures . . . [i]t is shown that the electron density increases explosively in time due to accumulation of atoms in the lowest excited states.” *Id.* at 30, Abs., Fig. 6.

Increasing excitation rate

GlobalFoundries relies upon Wang to disclose all of the structural limitations expressly recited in claims 1, 4, 10, and 12—namely, a magnetically enhanced sputtering apparatus that includes: (1) an anode; (2) a cathode assembly that is positioned adjacent to the anode, the cathode assembly including a sputtering target; (3) an ionization source; (4) a magnet; (5) a power supply generating a voltage pulse; (6) substrate support; and (7) a bias voltage power supply. Pet. 41–53. Indeed, Wang discloses these structural claim features, as well as their functionalities. *See, e.g.*, Ex. 1005, Abs., Fig. 1. For instance, Wang discloses a variable DC power supply (an ionization source) that is connected to the sputtering target, supplying a constant negative voltage to the target to generate a weakly-ionized plasma. *Id.* at 7:56–61, Figs. 6, 7.

The parties’ dispute mainly centers on: (1) whether the prior art combination renders obvious the effect or result limitations—the purportedly improved plasma characteristics resulted from applying a voltage pulse to a weakly-ionized plasma; and (2) whether GlobalFoundries has articulated a reason with rational underpinning why one with ordinary skill in the art would have combined the prior art teachings. For example, claim 1 recites “the power supply being configured to generate the voltage pulse . . . that *increases an excitation rate* of ground state atoms.” Ex. 1001, 21:35–46

(emphasis added). GlobalFoundries relies upon Wang to disclose a pulsed power supply that generates a series of voltage pulses, applying peak power pulses to a weakly-ionized plasma. Pet. 45–46 (citing Ex. 1005, 7:61–62, Fig. 7). Although Wang discloses the claimed structure (a power supply) performing the claimed function (applying a voltage pulse to a weakly-ionized plasma to increase the density of the plasma quickly without arcing) (Ex. 1005, 7:1–8:13, Figs. 6, 7), Wang does not describe expressly increasing excitation rate of the ground state atoms.

Nevertheless, GlobalFoundries asserts that Wang’s disclosed power levels of the power pulses fall within the ranges disclosed in the ’759 patent, and, therefore, “Wang is as likely as the ’759 patent to increase the excitation rate of ground state atoms within the weakly-ionized plasma and to cause multi-step ionization.” Pet. 47 (citing Ex. 1001, Fig. 5; Ex. 1005, 7:19–25). Dr. Overzet testifies (Ex. 1036 ¶ 83) and Zond’s expert, Dr. Hartsough, confirms (Ex. 1038, 99:14–23) that “the ionization rate of the strongly-ionized plasma is higher than that in the weakly-ionized plasma.” Dr. Overzet further testifies that when generating a strongly-ionized plasma from a weakly-ionized plasma, the ionization rate will increase. Ex. 1036 ¶ 83.

GlobalFoundries further alleges that, even if Wang does not disclose an increase in ionization rate, it would have been obvious, in light of Kudryavtsev’s teaching of an “explosive increase” in plasma density, to adjust Wang’s operating parameters to trigger a fast stage of ionization. Pet. 47–49. According to GlobalFoundries, triggering such a fast stage of ionization in Wang’s apparatus would increase plasma density, thereby

increasing the sputtering rate, and reducing the time required to reach a given plasma density. *Id.*

Zond counters that GlobalFoundries fails to demonstrate that one with ordinary skill in the art would have combined the systems of Wang and Kudryavtsev to achieve the claimed invention with reasonable expectation of success or predictable results. PO Resp. 14–34. In particular, Zond contends that GlobalFoundries does not take into consideration the substantial, fundamental structural differences between the systems of Wang and Kudryavtsev—e.g., pressure, chamber geometry, gap dimensions, and magnetic fields. *Id.* at 22–34 (citing, e.g., Ex. 1004, 32; Ex. 2005 ¶ 102; Ex. 1005, 4:35–37, Fig. 1). Zond also argues that GlobalFoundries fails to provide experimental data or other objective evidence to show that Wang’s system as modified would produce the claimed result. *Id.* at 32–34 (citing *Epistar v. Trs. of Boston Univ.*, Case IPR2013-00298 (PTAB Nov. 15, 2013) (Paper 18)).

In its Reply, GlobalFoundries responds that Zond’s arguments focus on bodily incorporating one system into the other. Reply 2–9. GlobalFoundries alleges that Zond improperly attempts to tie Kudryavtsev’s model on plasma characteristics to the particular dimensions and components of the apparatus used in the experiments that support Kudryavtsev’s model. *Id.* at 2, 6. According to GlobalFoundries, one with ordinary skill in the art would have understood how the structural differences would affect a magnetically enhanced sputtering system, and how to adjust for these differences to obtain the desired result. *Id.* at 6. GlobalFoundries also contends that *Epistar*, cited by Zond, which involved a direct substitution of a gallium layer for an aluminum layer, is inapplicable

to the particular facts in the instant proceeding, because the prior art combination here does not involve substitution of one apparatus feature for another. *Id.* at 8–9.

Upon consideration of the evidence before us, we are persuaded by GlobalFoundries’ contentions. GlobalFoundries merely relies upon Kudryavtsev’s teaching that an increase in the excitation rate is achieved by applying a voltage pulse to a weakly-ionized plasma. Pet. 47–49.

We also agree with GlobalFoundries that Zond’s reliance on its interpretation of *Epistar*, a non-precedential Board decision, is misplaced. “It is well-established that a determination of obviousness based on teachings from multiple references does not require an actual, physical substitution of elements.” *In re Mouttet*, 686 F.3d 1322, 1332 (Fed. Cir. 2012); *In re Etter*, 756 F.2d 852, 859 (Fed. Cir. 1985) (en banc) (noting that the criterion for obviousness is not whether the references can be combined physically, but whether the claimed invention is rendered obvious by the teachings of the prior art as a whole). In that regard, one with ordinary skill in the art is not compelled to follow blindly the teaching of one prior art reference over the other without the exercise of independent judgment. *Lear Siegler, Inc. v. Aeroquip Corp.*, 733 F.2d 881, 889 (Fed. Cir. 1984); *see also KSR*, 550 U.S. at 420–21 (stating that a person with ordinary skill in the art is “a person of ordinary creativity, not an automaton,” and “in many cases . . . will be able to fit the teachings of multiple patents together like pieces of a puzzle”).

We, further, are not persuaded by Zond’s argument that applying Kudryavtsev’s model on plasma behavior to Wang’s sputtering apparatus would have been beyond the level of ordinary skill, or that one with ordinary

skill in the art would not have had a reasonable expectation of success in combining the teachings. Obviousness does not require absolute predictability, only a reasonable expectation that the beneficial result will be achieved. *In re Merck & Co.*, 800 F.2d 1091, 1097 (Fed. Cir. 1986). As Dr. Overzet testifies, Kudryavtsev’s model on plasma behavior is not intended to be limited to a particular type of plasma apparatus. Ex. 1036 ¶ 55. Indeed, Kudryavtsev discloses a study of the ionization relaxation in plasma when the external electric field suddenly increases. Ex. 1004, 30. Specifically, Kudryavtsev discloses that “the *electron density increases explosively* in time due to accumulation of atoms in the lowest excited states.” *Id.* at Abs. (emphasis added). Kudryavtsev also describes the experimental results that confirm the model. *Id.* at 32–34. Moreover, Kudryavtsev expressly explains that “the effects studied in this work are characteristic of ionization *whenever a field is suddenly applied to a weakly ionized gas.*” *Id.* at 34 (emphasis added).

Dr. Overzet also testifies that a person having ordinary skill in the art “would have looked to Kudryavtsev to understand how plasma would react to a voltage pulse, and how to achieve an explosive increase in electron density” when generating a strongly-ionized plasma for improving sputtering and manufacturing processing. Ex. 1036 ¶ 56. Dr. Overzet further explains that such an artisan would have known how to apply Kudryavtsev’s model to Wang’s system by making any necessary changes to accommodate the differences through routine experimentation. *Id.* ¶¶ 57–58. On this record, we credit Dr. Overzet’s testimony (*id.* ¶¶ 55–58) because his explanations are consistent with the prior art of record.

Indeed, as GlobalFoundries points out (Pet. 25–28, 48), Kudryavtsev teaches the application of a voltage pulse to a weakly-ionized plasma. Ex. 1004, 32. Kudryavtsev explains that, in the initial stage, the number of atoms in the first excited state increases rapidly for a relatively slow change in the electron density, and “[t]he *rate of ionization then increases* with time.” *Id.* at 31 (emphasis added). Like Kudryavtsev, Wang applies a voltage pulse to a pre-existing, weakly-ionized plasma, quickly causing the plasma to spread and increasing the density of the plasma. Ex. 1005, 7:29–30, 61–63. Wang discloses a power supply being configured to generate a voltage pulse with an amplitude and a rise time. Ex. 1005, 7:56–8:13, Fig. 7. Significantly, it discloses power levels applied to the plasma that fall within the ranges disclosed in the ’759 patent. Ex. 1001, Fig. 5; Ex. 1005, 7:19–25. In particular, Wang discloses background power P_B of 1 kW (falling within the range of 0.1–100 kW, as disclosed in the ’759 patent, for generating a weakly-ionized plasma), and pulse peak power P_P of 1 MW (falling within the range of 1 kW–10 MW, as disclosed in the ’759 patent, for generating a strongly-ionized plasma). Ex. 1005, 7:19–25; Ex. 1001, 11:52–58, 12:24–36, Fig. 5.

When considering whether a claimed invention would have been obvious, “the knowledge of [a skilled] artisan is part of the store of public knowledge that must be consulted.” *Randall Mfg. v. Rea*, 733 F.3d 1355, 1362 (Fed. Cir. 2013). Notwithstanding that Dr. Hartsough provides a definition of “a person of ordinary skill in the art” in the context of the ’759

patent,⁶ we are mindful that the level of ordinary skill in the art also is reflected by the prior art of record. *See Okajima*, 261 F.3d at 1355. Here, as GlobalFoundries points out, Mozgrin applied Kudryavtsev’s teachings of “explosive increase” in plasma density to a magnetron sputtering system similar to Wang’s. Pet. 25–28, 41, 48; Reply 8; Ex. 1003, 401. Mozgrin cites to Kudryavtsev and discloses that in “[d]esigning the unit, we took into account the dependences which had been obtained in [Kudryavtsev] of ionization relaxation on pre-ionization parameters, pressure, and pulse voltage amplitude.” Ex. 1003, 401. This illustrates that one with ordinary skill in the art at the time of the invention was capable of applying the teachings of Kudryavtsev to well-known magnetron sputtering systems, such as Wang’s.

For the foregoing reasons, we are persuaded that GlobalFoundries has demonstrated, by a preponderance of evidence, that the proffered combination of Wang and Kudryavtsev discloses a power supply that generates a voltage pulse with an amplitude and a rise time that increases an excitation rate of ground state atoms, as recited in claim 1. GlobalFoundries also has articulated a reason with rational underpinning why one with ordinary skill in the art would have combined the technical teachings of Wang and Kudryavtsev.

⁶ “[A] person of ordinary skill in the art at the time of filing of the ’759 Patent [is] someone who holds at least a bachelor of science degree in physics, material science, or electrical/computer engineering with at least two years of work experience or equivalent in the field of development of plasma-based processing equipment.” Ex. 2005 ¶ 13.

Voltage pulse

Claim 1 recites:

the power supply being configured to generate the *voltage pulse* with an amplitude and a rise time that increases an excitation rate of ground state atoms that are present in the *weakly-ionized plasma* to create a multi-step ionization process that generates a *strongly-ionized plasma*, which comprises ions that sputter target material, from the weakly-ionized plasma

Ex. 1001, 21:37–44 (emphases added).

In its Response, Zond argues that the combination of Wang and Kudryavtsev does not teach or suggest a “voltage pulse” as recited in claim 1. PO Resp. 35–45. In particular, Zond alleges that neither Wang nor Kudryavtsev describes a weakly-ionized plasma and a strongly-ionized plasma, because they do not disclose certain *specific ion density ranges*. *Id.* at 44–45. Zond further argues that Wang controls *power* pulses, rather than *voltage* pulses. *Id.* at 36–39. Zond also contends that neither Wang nor Kudryavtsev describes *choosing* a rise time and amplitude of the voltage pulse to increase an excitation rate of ground state atoms. *Id.* at 39–45.

Zond’s arguments, however, are not commensurate with the scope of the claims. *See In re Self*, 671 F.2d 1344, 1348 (CCPA 1982) (stating that limitations not appearing in the claims cannot be relied upon for patentability). As we explained previously in the claim construction section, the claim terms “a weakly-ionized plasma” and “a strongly-ionized plasma” do not require specific ion density ranges. Rather, in light of the Specification, we construe the claim term “a weakly-ionized plasma” as “a plasma with a relatively low peak density of ions” and the claim term

“a strongly-ionized plasma” as “a plasma with a relatively high peak density of ions.”

As GlobalFoundries explains in its Petition (Pet. 42–47), Wang discloses a variable DC power supply that applies a constant negative voltage, corresponding to the background power P_B , to generate a low-density plasma (a weakly-ionized plasma). Ex. 1005, 7:17–61, Figs. 6, 7. Wang applies a voltage pulse to the weakly-ionized plasma, producing a very high-density plasma (a strongly-ionized plasma). *Id.* at Abs. Kudryavtsev expressly discloses that applying a voltage pulse with a rise time (e.g., $1-2 \times 10^{-7}$ seconds) to a weakly-ionized plasma causes an increase in excitation rate of ground state atoms. Ex. 1004, 31–32, Fig. 1 (“*The rate of ionization then increases with time and rises . . . [T]he subsequent increase in n_e [plasma density] then reaches its maximum value, . . . which is several orders of magnitude greater than the ionization rate during the initial stage.*”) (emphasis added). As discussed above, Dr. Overzet testifies that “the ionization rate of the strongly-ionized plasma is higher than that in the weakly-ionized plasma,” and, therefore, when creating a strongly-ionized plasma from a weakly-ionized plasma, the ionization rate will increase. Ex. 1036 ¶ 83. In sum, the combination of Wang and Kudryavtsev collectively discloses a multi-step ionization process, increasing the excitation rate of ground state atoms and generating a strongly-ionized plasma from a weakly-ionized plasma.

Zond also attempts to import limitations—“choosing an amplitude and a rise time” and “controlling voltage pulses”—from the Specification into the claims at issue. PO Resp. 39–45. In any event, even if the claims being challenged in this proceeding recite such limitations, we are not persuaded

by Zond's arguments that these limitations are not taught or suggested by the combination of Wang and Kudryavtsev.

Contrary to Zond's assertion that Wang does not control *voltage* pulses, Wang explicitly discloses a pulsed power supply that "produces a train of negative *voltage pulses*." See Pet. 45; Ex. 1005, 7:56–62 (emphasis added). Furthermore, as Dr. Kortshagen explains, "[t]hose voltage pulses create Wang's peak power pulses, P_P , which are applied to Wang's weakly-ionized plasma, i.e., the plasma generated by the background power, P_B ." Ex. 1002 ¶ 134.

Dr. Overzet also explains Wang discloses that "a magnitude (amplitude) of the voltage pulse at the power supply is selected and delivered to the reactor chamber during the peak power pulse P_P ." Ex. 1036 ¶ 66 (citing Ex. 1005, 7:19–22, 7:65–8:1, 9:30–40, Fig. 7). Dr. Overzet further explains that "to generate a power pulse, a *voltage pulse* with a specific amplitude and rise time is first provided by the power supply." *Id.* ¶¶ 47–48 (emphasis added). Dr. Overzet testifies that "Wang describes controlling both the magnitude and rise time of the voltage pulse at the power supply such that the electrical pulse is sufficient to increase the density of the weakly-ionized plasma and generate a strongly-ionized plasma." *Id.* ¶ 66.

Figure 7 of Wang is reproduced below (green annotation added):

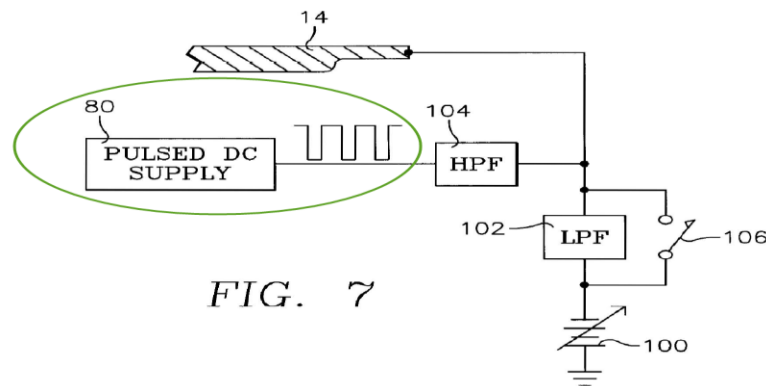

Indeed, as shown in Figure 7 of Wang, variable DC power supply 100 is connected to target 14 through low-pass filter 102, and supplies a voltage to target 14, corresponding to the background power P_B that generates a weakly-ionized plasma. Ex. 1005, 7:56–8:1. Pulsed DC power supply 80 is connected to target 14, in parallel to DC power supply 100 and through high-pass filter 104, and produces a series of *voltage pulses*. *Id.* The time constant of high-pass filter 104 is chosen to fall between the pulse width τ_w —which includes a rise time—and the pulse repetition period τ_p . *Id.* Zond’s expert, Dr. Hartsough, agrees that a high-pass filter “could enable fast rise times.” Ex. 1039, 181:9–17. As discussed above, Wang’s power levels fall within the ranges disclosed in the ’759 patent. Ex. 1001, Fig. 5; Ex. 1005, 7:19–25. Given the evidence before us, we credit Dr. Kortshagen’s testimony (Ex. 1002 ¶ 134) and Dr. Overzet’s testimony (Ex. 1036 ¶¶ 47–48, 66), as it is consistent with the prior art disclosures.

We also are not persuaded by Zond’s argument and Dr. Hartsough’s testimony that the amplitude and rise time of the voltage pulses in Wang are not controlled but, instead, vary randomly with the current. PO Resp. 36–39; Ex. 2005 ¶¶ 111–15. Zond’s argument and expert testimony are

predicated on a narrow view of Wang, focusing on Wang's first embodiment in which the "chamber impedance dramatically changes." Ex. 1005, 5:29–31. In fact, in Wang's second embodiment, as shown in Figures 6 and 7, Wang expressly indicates that "the chamber impedance changes relatively little between the two power levels P_B , P_P since a plasma always exist[s] in the chamber." Ex. 1005, 7:47–51. As Dr. Overzet testifies, the relatively constant impedance allows Wang's voltage amplitude and rise time to be controlled. Ex. 1036 ¶¶ 73–74. Upon review of the evidence before us, we credit the testimony of Dr. Overzet (Ex. 1036 ¶¶ 73–74) over that of Dr. Hartsough (Ex. 2005 ¶¶ 111–15) because Dr. Overzet's testimony is consistent with Wang's disclosure. *See Yorkey v. Diab*, 601 F.3d 1279, 1284 (Fed. Cir. 2010) (holding that Board has discretion to give more weight to one item of evidence over another "unless no reasonable trier of fact could have done so").

Zond's argument and expert testimony also do not consider Wang, as a whole, in the context of what was generally known in the art at the time of the invention. *See Translogic*, 504 F.3d at 1259–62 (stating that prior art must be read in context, taking account of the general knowledge possessed by a person with ordinary skill in the art); *Randall Mfg.*, 733 F.3d at 1362. Here, Kudryavtsev discloses an increase in the ionization rate when a *voltage pulse* with a rise time of $1-2 \times 10^{-7}$ seconds is applied to a weakly-ionized plasma. Ex. 1004, 31–34. We observe that Kudryavtsev's rise time falls squarely within the range of 1×10^{-7} seconds to 10 seconds disclosed in the '759 patent (Ex. 1001, 10:63–65). Moreover, as we noted above, Mozgrin illustrates that one of ordinary skill in the art at the time of the invention would have appreciated Kudryavtsev's teachings and applied

them to a magnetron sputtering system, generating a strongly-ionized plasma from a weakly-ionized plasma by applying a voltage pulse with a preselected amplitude and rise time. Ex. 1003, 401–06 (“Designing the unit, we took into account the dependences which had been obtained in [Kudryavtsev] of ionization relaxation on pre-ionization parameters, pressure, and pulse voltage amplitude.”). The Admitted Prior Art also discloses a well-known magnetron sputtering system in which a voltage pulse is applied between the cathode and anode that has a specific amplitude sufficient to ionize the gas and increase the amount of ionized gas, but low enough to avoid undesirable electrical discharges and target heating. Ex. 1001, 2:60–3:65, Fig. 1. Given the prior art disclosures in this record, we agree with Dr. Overzet’s testimony that a person with ordinary skill in the art would have understood that the amplitude and rise time of the voltage pulses in Wang are selected in order to increase the ionization rate of ground state atoms in the weakly-ionized plasma. See Ex. 1036 ¶ 68.

Based on the evidence before us, we are persuaded that GlobalFoundries has demonstrated, by a preponderance of evidence, that the combination of Wang and Kudryavtsev discloses controlling the voltage pulses and selecting an amplitude and a rise time of the voltage pulses to increase an excitation rate of ground state atoms that are present in weakly-ionized plasma.

Creating a multi-step ionization process without forming an arc discharge

Claim 1 recites:

the *multi-step ionization process* comprising exciting the ground state atoms to generate excited atoms, and then ionizing

the excited atoms within the weakly-ionized plasma *without forming an arc discharge*.

Ex. 1001, 21:44–48 (emphases added). As we articulated above, in light of the Specification, the claim term “without forming an arc discharge” is construed as “substantially eliminating the possibility of arcing.”

In its Petition, GlobalFoundries takes the position that the combination of Wang and Kudryavtsev collectively discloses this claim limitation. Pet. 14–15, 47–50 (citing Ex. 1002 ¶¶ 143–144). As discussed previously, the combination of Wang and Kudryavtsev discloses a multi-step ionization process, exciting the ground state atoms to generate excited atoms, and then ionizing the excited atoms within the weakly-ionized plasma to generate a strongly-ionized plasma. Like the '759 patent (Ex. 1001, 11:54–64, 15:49–53), Wang generates a weakly-ionized plasma in the background between the voltage pulses to avoid arcing (Ex. 1005, 7:1–8:13, Figs. 6, 7).

In its Response, Zond counters that Wang suggests arcing does occur after ignition because Wang states that “[p]lasma ignition . . . has a tendency to generate particles during the initial arcing, which may dislodge large particles from the target or chamber.” PO Resp. 48–49 (citing Ex. 1005, 7:3–6). Zond also contends that Wang does not state that arcing is reduced after ignition, but rather Wang discloses that the “*particulates* produced by arcing are much reduced,” suggesting that arcing will continue to occur subsequent to ignition. *Id.* at 49 (citing Ex. 1005, 7:47–49 (emphasis added by Zond)). To support Zond’s contention, Dr. Hartsough testifies that Wang does not state that arcing either does not occur, or is substantially eliminated,

while the ground state atoms are excited to generate excited atoms or while the excited atoms are ionized. Ex. 2005 ¶¶ 122–127.

Based on evidence before us, we are not persuaded by Zond’s arguments and expert testimony. An obviousness analysis is not an *ipsissimis verbis* test. See *In re Gleave*, 560 F.3d 1331, 1334 (Fed. Cir. 2009). Rather, a *prima facie* case of obviousness is established when the prior art itself would appear to have suggested the claimed subject matter to one of ordinary skill in the art. *In re Rinehart*, 531 F.2d 1048, 1051 (CCPA 1976).

Zond’s arguments and expert testimony also conflate Wang’s first embodiment with Wang’s second embodiment, and narrowly focus on the discussion regarding the disadvantages of Wang’s first embodiment. In fact, Wang acknowledges that the on-and-off pulsing in the first embodiment (shown in Figure 4) can be improved further by maintaining a background power level P_B between pulses to avoid arcing, as illustrated by Wang’s second embodiment shown in Figure 6. See Ex. 1005, 7:1–8:13.

Figures 4 and 6 of Wang are reproduced below, with red annotations added by Dr. Overzet (Ex. 1036 ¶ 73).

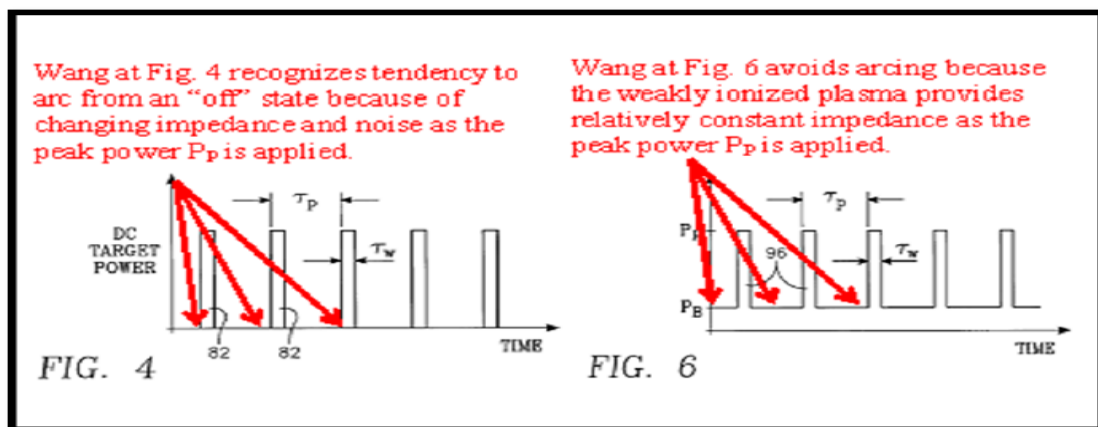

As shown in annotated Figures 4 and 6 above, Wang discloses that it is advantageous to maintain a background power level P_B between the high power pulses. Ex. 1005, 7:13–17. Notably, Wang recognizes that, in the first embodiment (shown in Figure 4), because the plasma is ignited with a high power pulse in each pulse cycle, the chamber impedance dramatically changes between the on-and-off phases, and large particles are dislodged from the target or chamber. *Id.* at 5:28–32, 7:1–13. By contrast, in Wang’s second embodiment (as shown in Figure 6), the plasma is ignited only once at a much lower power level (P_B). *Id.* at 7:47–55. Since the plasma always exists after ignition, the chamber impedance changes relatively little, and particulates produced by arcing are reduced substantially. *Id.*

Dr. Overzet testifies that the relatively constant impedance allows the strongly-ionized plasma to be generated without arcing. Ex. 1036 ¶¶ 74–75. Indeed, Zond’s expert, Dr. Hartsough, confirms that “if the impedance changes relatively little during the transition from a low-[density plasma] to a high-density plasma, then it’s indicative of no short circuit or arcing.” Ex. 1041, 88:23–89:24. Given the prior art disclosures and evidence before us, we credit Dr. Overzet’s testimony (Ex. 1036 ¶¶ 74–75).

Zond further alleges that Kudryavtsev’s system forms an arc discharge during the multi-step ionization process. PO Resp. 50–51. As support, Dr. Hartsough testifies that the voltage and current versus time plot shown in Figure 2 of Kudryavtsev, demonstrates that Kudryavtsev’s system forms an arc discharge. Ex. 2005 ¶ 127.

Zond’s argument and expert testimony, however, narrowly focus on Figure 2 of Kudryavtsev, and fail to consider Kudryavtsev’s teachings regarding the arc-free embodiment. In fact, Kudryavtsev identifies

conditions that may result in arcing as well as conditions that avoid arcing. Ex. 1004, 34. In particular, Kudryavtsev discloses that certain experiments have shown that “ionization occurs *uniformly* over a cross section of the discharge tube when a field is applied to a pre-ionized gas,” and “ionization develops more *uniformly* in the bulk, in good agreement with experiment.” *Id.* (emphases added). Dr. Overzet testifies that “a uniform plasma is indicative of a substantially constant degree of ionization across the electrodes and thus, indicative of an arc-free condition.” Ex. 1036 ¶ 34. We credit Dr. Overzet’s testimony (Ex. 1036 ¶ 34) because it is consistent with the prior art of record.

Given the evidence before us in this entire record, we determine that GlobalFoundries has demonstrated, by a preponderance of evidence, that the combination of Wang and Kudryavtsev would have suggested to one with ordinary skill in the art at the time of the invention a “multi-step ionization process comprising exciting the ground state atoms to generate excited atoms, and then ionizing the excited atoms within the weakly-ionized plasma *without forming an arc discharge,*” as recited in claim 1.

Conclusion

For the foregoing reasons, we conclude that GlobalFoundries has demonstrated, by a preponderance of evidence that claims 1, 4, 10, and 12 are unpatentable over the combination of Wang and Kudryavtsev.

D. Claim 11—Obviousness over Wang, Kudryavtsev, and Li

GlobalFoundries asserts that claim 11 is unpatentable under § 103(a) as obvious over the combination Wang, Kudryavtsev, and Li. Pet. 38–39,

54. In its Petition, GlobalFoundries alleges that Li discloses a magnetron sputtering apparatus with “a temperature controller that controls the temperatures of the substrate support,” as recited in claim 11. *Id.* (citing Ex. 1020, 2334, Fig. 1). As discussed previously, Figure 1 of Wang shows that pedestal 18 supports semiconductor substrate 20. Ex. 1005, 3:63–66. Wang also discloses a temperature controller for controlling the substrate support temperature. *See* U.S. Patent Application No. 09/414,614⁷ (“Unillustrated resistive heaters, refrigerant channels, and thermal transfer gas cavity in the pedestal 62 allow the temperature of the pedestal to be controlled.”). According to Dr. Kortshagen, it would have been obvious to one with ordinary skill in the art to use a temperature controller in Wang’s apparatus to control the substrate support temperature, “so as to control grain growth of Wang’s deposited metal as well as to assist with conformal filling of features, such as trenches, with Wang’s deposited material.” Ex. 1002 ¶ 160.

In its Response, Zond counters that Li does not teach controlling the substrate support temperature, as required by claim 11, because Li discloses controlling the *substrate* temperature, and not the *substrate support* temperature. PO Resp. 51–52. As GlobalFoundries notes, however, Li discloses an apparatus where a heater is placed beneath the substrate support and the temperature is “measured by a thermocouple attached to the substrate holder.” Ex. 1020, 2334. Based on the evidence before us, we agree with GlobalFoundries that controlling the substrate support

⁷ U.S. Patent Application No. 09/414,614 is incorporated by reference in Wang. Ex. 1005, 1:46–51.

temperature in a pulsed magnetron sputtering system was well known in the art at the time of the invention, as evidenced by Wang and Li.

For the foregoing reasons, we conclude that GlobalFoundries has demonstrated, by a preponderance of evidence, that claim 11 is unpatentable over the combination of Wang, Kudryavtsev, and Li.

E. Claim 17—Obviousness over Wang, Kudryavtsev, and Müller-Horsche

GlobalFoundries asserts that claim 17 is unpatentable under § 103(a) as obvious over the combination of Wang, Kudryavtsev, and Müller-Horsche. Pet. 54–59. Claim 17 depends from claim 1, and recites “wherein the ionization source [that generates a weakly-ionized plasma] is chosen from the group comprising a *UV source*, an X-ray source, an electron beam source, and an ion beam source.” Ex. 1001, 22:28–31 (emphasis added).

According to GlobalFoundries, Müller-Horsche discloses a UV source for pre-ionization, generating a weakly-ionized plasma, to avoid arcing. Pet. 39–41, 54–55; Ex. 1021, 1:34–36 (“The pre-ionization of the gas . . . is carried out in particular also to avoid arc discharges.”), 1:40–42 (“Typically, in such a pre-ionizing relatively low electron concentrations (for example 10^7 electrons/cm³) are generated in the discharge space.”). Dr. Kortshagen testifies that “one of ordinary skill in the art would have been motivated to combine the use of different ionization sources, such as those described by Müller-Horsche with the teachings of Wang.” Ex. 1002 ¶¶ 163–65.

Zond counters that the prior art combination does not render claim 17 obvious. PO Resp. 52–56. To support its contention, Zond advances two arguments. First, Zond argues that “Wang teaches away from the type of

pulsed energy pre-ionization that is a key aspect of Müller-Horsche,” because Wang teaches “a continuous pre-ionized gas for the stated advantage of not having to strike the arc at each pulse.” *Id.* at 53–54 (citing Ex. 1005, 7:3–17; Ex. 1021, 4:65–5:6).

Upon review the evidence before us, we are not persuaded by Zond’s argument. “A reference may be said to teach away when a person of ordinary skill, upon reading the reference, would be discouraged from following the path set out in the reference, or would be led in a direction divergent from the path that was taken by the [inventor].” *In re Gurley*, 27 F.3d 551, 553 (Fed. Cir. 1994). A reference, however, does not teach away if it merely expresses a general preference for an alternative invention but does not “criticize, discredit, or otherwise discourage” investigation into the invention claimed. *In re Fulton*, 391 F.3d 1195, 1201 (Fed. Cir. 2004).

Here, the portion of Wang relied upon by Zond does not discuss a UV source, much less teach away from using a UV source for pre-ionization to generate a weakly-ionized plasma. Zond’s argument and expert testimony again conflate Wang’s first embodiment with Wang’s second embodiment, and narrowly focus on Wang’s first embodiment in which the gas is *not pre-ionized* and the plasma is ignited using a *high power pulse*. PO Resp. 53–55; Ex. 2005 ¶¶ 166–168 (citing Ex. 1005, 7:3–17). By contrast, in the second embodiment, Wang teaches the advantages of generating a weakly-ionized plasma, to *pre-ionize the gas*, before applying the high power pulses. *Id.* at 7:13–8:12. We do not discern that these advantages criticize, discredit, or otherwise discourage using a UV source.

Moreover, Zond’s expert, Dr. Hartsough, confirms that “using a UV source to ionize gas was well known in the art.” Ex. 1038, 63:12–15.

Indeed, Müller-Horsche discloses a UV source for pre-ionization, generating a weakly-ionized plasma, to avoid arcing. Ex. 1021, 1:34–42. Zond’s argument also fails to consider Müller-Horsche, as a whole, which describes using *constant* power supply as well as using *pulsed* power supply for the pre-ionization. *Id.* at 2:52–63.

Second, Zond argues that, because Müller-Horsche teaches reducing electrode erosion or sputtering, Müller-Horsche teaches away from the very purpose of Wang’s *sputtering* apparatus. *Id.* at 55–56 (citing Ex. 2005 ¶ 169; Ex. 1021, 6:14–21). The portion of Müller-Horsche relied upon by Zond and its expert, however, is directed to the *main electrodes* that are not involved in the pre-ionization process. Ex. 1021, 6:18–21 (“Such solid profile *main electrodes* . . . have advantages as regards the erosion behavior and the control of the discharge cross-section.”). GlobalFoundries merely relies upon Müller-Horsche’s *UV pre-ionization source* for generating a weakly-ionized plasma, and not the *main electrodes*, in its proposed prior art combination. Pet. 40, 54–55. Obviousness does not require that all of the features of one reference be bodily incorporated into the other reference. *In re Keller* 642 F.2d 413, 425 (CCPA 1981).

Based on the prior art disclosures, we agree with Dr. Kortshagen’s testimony (Ex. 1002 ¶ 165) that substituting Wang’s ionization source with Müller-Horsche’s UV source for generating a weakly-ionized plasma is no more than “the predictable use of prior art elements according to their established functions.” *KSR*, 550 U.S. 417. For the foregoing reasons, we conclude that GlobalFoundries has demonstrated, by a preponderance of evidence, that claim 17 is unpatentable over the combination of Wang, Kudryavtsev, and Müller-Horsche.

F. Claim 18—Obviousness over Wang, Kudryavtsev, and Kobayashi

GlobalFoundries asserts that claim 18 is unpatentable under § 103(a) as obvious over the combinations of Wang, Kudryavtsev, and Kobayashi. Pet. 55–56. Claim 18 depends from claim 1, and further recites “wherein the magnet comprises an electro-magnet.” Ex. 1001, 22:32–33. According to GlobalFoundries, Kobayashi discloses a magnetron sputtering apparatus that includes electromagnets. Pet. 55–56 (citing Ex. 1022, 4:14–20). Dr. Kortshagen testifies that it would have been obvious “to use Kobayashi’s electromagnet in Wang so as to more precisely control the magnetic field.” Ex. 1002 ¶ 169. With respect to this ground of unpatentability, Zond essentially relies upon the same arguments presented in connection with independent claim 1. PO Resp. 13–45. We addressed those arguments in our analysis above, and found them unavailing. Upon review of the parties’ contentions and supporting evidence, we determine that GlobalFoundries has established, by a preponderance of evidence, that claim 18 is unpatentable over the combination of Wang, Kudryavtsev, and Kobayashi.

G. Claim 44—Obviousness over Wang, Kudryavtsev, and Mozgrin Thesis

GlobalFoundries asserts that claim 44 is unpatentable under § 103(a) as obvious over the combinations of Wang, Kudryavtsev, and the Mozgrin Thesis. Pet. 33–36, 54–59.

Printed Publication under 35 U.S.C. § 102

As an initial matter, we address the issue of whether the Mozgrin Thesis is available as prior art under 35 U.S.C. § 102(b)⁸ for purposes of this Final Written Decision. The determination of whether a given reference qualifies as a prior art “printed publication” involves a case-by-case inquiry into the facts and circumstances surrounding the reference’s disclosure to members of the public. *In re Klopfenstein*, 380 F.3d 1345, 1350 (Fed. Cir. 2004). “Because there are many ways in which a reference may be disseminated to the interested public, ‘public accessibility’ has been called the touchstone in determining whether a reference constitutes a ‘printed publication’ bar under 35 U.S.C. § 102(b).” *In re Hall*, 781 F.2d 897, 898–99 (Fed. Cir. 1986). To qualify as a prior art printed publication, the reference must have been disseminated or otherwise made accessible to persons interested and ordinarily skilled in the subject matter to which the document relates prior to the critical date. *Kyocera Wireless Corp. v. Int’l Trade Comm’n*, 545 F.3d 1340, 1350 (Fed. Cir. 2008).

Here, GlobalFoundries asserts that the Mozgrin Thesis is a doctoral thesis at Moscow Engineering Physics Institute, published in 1994, and, thus, it is prior art under § 102(b). Pet. 3. To support its assertion, GlobalFoundries proffers a copy of the catalog entry for the Mozgrin Thesis at the Russian State Library, and a certified English-language translation thereof. Ex. 1019. GlobalFoundries also alleges that the Mozgrin Thesis

⁸ Paragraph (b) of 35 U.S.C. § 102 was replaced with newly designated § 102(a)(1) when § 3(b)(1) of AIA took effect on September 16, 2012. Because the application that issued as the ’759 patent was filed before that date, we refer to the pre-AIA version of § 102.

was cataloged by the Russian State Library either by the imprint date of 1994 or at least by 1995, as shown on the catalog entry (“Catalog of Dissertations in Russian (since 1995)”). Reply 21–22. GlobalFoundries further asserts that the Russian State Library is an institution “by definition established to share the information that it houses with any interested person.” *Id.* Dr. Kortshagen testifies that Mozgrin—an article that was published in 1995 (Ex. 1003)—summarizes the research presented in the Mozgrin Thesis, and contains figures created from the photographs in the Mozgrin Thesis. Ex. 1002 ¶ 95.

In its Response, Zond counters that GlobalFoundries fails to demonstrate that the Mozgrin Thesis is prior art under § 102. PO Resp. 59–60. Zond contends that GlobalFoundries provides no evidence that the phrase “Imprint Moscow 1994” appearing on the catalog entry means that the Mozgrin Thesis was cataloged on that particular date. *Id.*

Upon consideration of the facts in the present record, we are persuaded by GlobalFoundries’s contentions and supporting evidence. Although evidence establishing a *specific* date of cataloging and shelving before the critical date would have been desirable, it is not required in a public accessibility determination. *See Hall*, 781 F.2d at 899. Here, the critical date is *September 30, 2002*—the filing date of the application that issued as the ’759 patent. Ex. 1001, at [22].

The certified English-language translation of the catalog entry is reproduced below with green annotations added (Ex. 1019, 1):

Logotype of RSL		Catalog of Dissertations in Russian (since 1995)	
Full View of Record			
Global Holdings		<u>All items</u>	
Holdings		<u>Department of dissertations (Khimki) 61 95-1/593-2</u>	
Author		<u>Mozgrin Dmitry Vitalievich</u>	
Title		<u>High-current low-pressure quasi-stationary discharge in a magnetic field; experimental research: ph.d. thesis in physics and mathematics: 01.04.08</u>	
Imprint		<u>Moscow 1994</u>	
Description		<u>122 pages, illustrations</u>	
Language		<u>Russian</u>	
Bibliography		<u>Bibliography: pages 111-122</u>	
Subject – Other		<u>Plasma physics and chemistry</u>	
Electronic Location		<u>http://dlib.rsl.ru/rs/0100000000/rs/01000165000/rs/01000165287/rs/01000165287.pdf</u>	
Parallel record		<u>Synopsis of a thesis</u>	

As depicted above, the catalog entry shows that it is an entry from the Russian State Library's catalog of dissertations in Russian. Ex. 1019, 2. As we determined previously in the Decision on Institution (Dec. 7–9), the catalog entry clearly shows a publication date of 1994 (“Imprint Moscow 1994”), well before the critical date of September 30, 2002. *Id.*

Zond had the opportunity, during this trial, to object to evidence and file a motion to exclude the evidence submitted by GlobalFoundries. As noted by GlobalFoundries, however, Zond did not object under 37 C.F.R. § 42.64(b) to the admissibility of the catalog entry or the Mozgrin Thesis. Reply 22. Notably, Zond does not challenge the authenticity of these documents, nor allege that they constitute inadmissible hearsay. Therefore, the information set forth in catalog entry can be relied upon by GlobalFoundries as evidence supporting its contention that Mozgrin Thesis was sufficiently accessible to the public before the critical date and it is printed publication within the meaning of § 102. Furthermore, Zond does not provide sufficient explanation or credible evidence to rebut the

information disclosed in the Russian State Library's catalog entry, including the 1994 publication date. For instance, Zond does not explain why a library, such as the Russian State Library here, would take more than seven years to catalog and index a thesis.

Zond further alleges that the Mozgrin Thesis was not sufficiently accessible to be considered a printed publication under § 102. PO Resp. 59–60. According to Zond, even if the thesis had been cataloged in a library in Russia, GlobalFoundries “would not have demonstrated that the thesis could have been obtained by any interested person outside of Russia or the countries under Russia's control.” *Id.* at 60.

Zond's argument is misplaced, as it is predicated on the notion that a cataloged thesis available in Russia, a foreign country, does not constitute sufficient accessibility to interested persons exercising reasonable diligence. Zond does not cite, nor can we discern, any authority that requires a cataloged thesis to be located physically in this country. Notably, the Federal Circuit has rejected the argument that a cataloged thesis shelved in a university library in Germany does not constitute sufficient accessibility to those interested in the art exercising reasonable diligence. *Hall*, 781 F.2d at 899–900. The Federal Circuit also has held that an Australian patent application—classified and laid open to public inspection by the Australian Patent Office—was sufficiently accessible to interested persons to qualify as a prior art printed publication under § 102. *In re Wyer*, 655 F.2d 221, 225–26 (Fed. Cir. 1981). Zond does not proffer any specific explanation as to why we should treat Russia differently than any other foreign country.

Based on the evidence before us, we observe that the Mozgrin Thesis was cataloged and indexed in a meaningful way, by the author's name, the

title of the thesis (“High-Current Low-Pressure Quasi-Stationary Discharge in a Magnetic Field”), and the subject matter of the thesis (“Plasma Physics and Chemistry”). Ex. 1019. As such, the catalog entry demonstrates that the Mozgrin Thesis was made available to interested persons by virtue of its title and “Subject” characterization. Upon consideration of the facts before us, we determine that the Russian State Library’s catalog entry is credible evidence to establish that the Mozgrin Thesis was made sufficiently accessible to the public interested in the art before the critical date of September 30, 2002.

Based on the totality of the circumstances, we are persuaded that GlobalFoundries has established, by a preponderance of the evidence, that the Mozgrin Thesis is a printed publication under § 102.

The Rise time of the voltage pulse

Claim 44 depends from claim 1, and recites “wherein the rise time of the voltage pulse is approximately between 0.01 and 100 V/ μ sec.” Ex. 1001, 24:32–34. According to GlobalFoundries, the research presented in the Mozgrin Thesis (Ex. 1017) is summarized in Mozgrin (Ex. 1003). Pet. 33. The Mozgrin Thesis discloses a pulsed magnetron sputtering system. Ex. 1017, 36, Fig. 2. As Dr. Kortshagen explains, the Mozgrin Thesis discloses a rise time range of about 1.2–72 V/ μ sec, falling squarely within the claimed range. Ex. 1002 ¶ 177 (citing Ex. 1017, 42, Fig. 3.2). Dr. Kortshagen testifies that one of ordinary skill in the art would have optimized the voltage pulses and pulse characteristics, including the rise time of the voltage pulse, to achieve the desired plasma densities and sputtering results. *Id.* ¶¶ 177–78.

Zond counters that the combination of Wang, Kudryavtsev, and the Mozgrin Thesis does not render claim 44 obvious. PO Resp. 56–59. In particular, Zond and its expert contend that the process pressures cited as critical in Wang and the Mozgrin Thesis teach away from each other. PO Resp. 57; Ex. 2005 ¶ 146–148. As support, Dr. Hartsough testifies that in light of these significant differences in Wang and the Mozgrin Thesis, one of ordinary skill in the art would not have had a reasonable expectation of success of combining the voltage rise time and other teachings of the Mozgrin Thesis with Wang to achieve subject matter of claim 44. Ex. 2005 ¶ 148.

A reference does not teach away, however, if it merely expresses a general preference for an alternative invention but does not “criticize, discredit, or otherwise discourage” investigation into the invention claimed. *Fulton*, 391 F.3d at 1201. The portion of the Mozgrin Thesis relied upon by Zond and Dr. Hartsough does not discuss a voltage pulse, let alone teach away from the claimed rise time range of a voltage pulse. Ex. 1017, 98. Rather, that portion of the Mozgrin Thesis merely explains the effect of using a low-pressure range with a moderate magnetic field. *Id.*

More importantly, we do not discern that using different pressures in the Mozgrin Thesis and Wang criticizes, discredits, or otherwise discourages the claimed rise time range of a voltage pulse. As Dr. Overzet explains, process variables, such as pressure, are routine variables that one of ordinary skill in the art would work with on a regular basis. Ex. 1036 ¶ 108. Indeed, Mozgrin discloses routine parameters of a voltage pulsed magnetron plasma apparatus that include a pressure range of 1–500 milliTorr, overlapping with

the Mozgrin Thesis (10 milliTorr) and Wang's range (1–5 milliTorr).
Ex. 1003, 406, Table 1; Ex. 1017, 98; Ex. 2004, 6:60–62.

Dr. Overzet also explains that “[t]he claimed range of between 0.01 and 100 V/ μ sec for a pulse rise time is extremely large – a factor of 10,000 between the low and high limits of the range.” Ex. 1036 ¶ 107. The Mozgrin Thesis discloses a voltage pulse rise time range of about 1.2–72 V/ μ sec, falling squarely within the claimed range. Ex. 1017, 4, Fig. 3.2. It is well settled that a *prima facie* case of obviousness typically exists when the claimed ranges overlap the ranges disclosed in the prior art. *In re Peterson*, 315 F.3d 1325, 1329 (Fed. Cir. 2003). “Such overlap itself provides sufficient motivation to optimize the ranges.” *In re Applied Materials, Inc.*, 692 F.3d 1289, 1295 (Fed. Cir. 2012); *Peterson*, 315 F.3d at 1330 (“The normal desire of scientists or artisans to improve upon what is already generally known provides the motivation to determine where in a disclosed set of . . . ranges is the optimum combination . . .”).

Dr. Overzet also explains that the voltage pulse rise time disclosed in the Mozgrin Thesis is for the purpose of transitioning from a low-density to a high-density plasma, similar to Wang—forming a strongly-ionized plasma by applying voltage pulses to a weakly-ionized plasma. Ex. 1036 ¶ 108. Dr. Overzet testifies that a person of ordinary skill in the art would have used the rise time disclosed in the Mozgrin Thesis in Wang's system with a reasonable expectation of success. *Id.* Based on the evidence before us including the prior art of record, we are persuaded that one of ordinary skill in the art would have been motivated to optimize the voltage pulses and pulse characteristics, including the rise time of the voltage pulse, to achieve the desired plasma densities and sputtering results. *See In re Boesch*,

617 F.2d 272, 276 (CCPA 1980) (“[D]iscovery of an optimum value of a result effective variable in a known process is ordinarily within the skill of the art.”).

For the foregoing reasons, we determine that GlobalFoundries has demonstrated, by a preponderance of evidence, that claim 44 is unpatentable over the combination of Wang, Kudryavtsev, and the Mozgrin Thesis.

III. CONCLUSION

For the foregoing reasons, we conclude that GlobalFoundries has demonstrated, by a preponderance of the evidence, that claims 1, 4, 10–12, 17, 18, and 44 of the ’759 patent are unpatentable based on the following grounds of unpatentability:

Claims	Basis	References
1, 4, 10, 12	§ 103(a)	Wang and Kudryavtsev
11	§ 103(a)	Wang, Kudryavtsev, and Li
17	§ 103(a)	Wang, Kudryavtsev, and Müller-Horsche
18	§ 103(a)	Wang, Kudryavtsev, and Kobayashi
44	§ 103(a)	Wang, Kudryavtsev, and the Mozgrin Thesis

IV. ORDER

In consideration of the foregoing, it is

ORDERED that claims 1, 4, 10–12, 17, 18, and 44 of the ’759 patent are held *unpatentable*; and

IPR2014-01086
Patent 7,147,759 B2

FURTHER ORDERED that, because this is a final written decision, parties to the proceeding seeking judicial review of the decision must comply with the notice and service requirements of 37 C.F.R. § 90.2.

STEPHENS, *Administrative Patent Judge, dissenting-in-part.*

I respectfully disagree with the Majority's determination that Mozgrin Thesis is prior art under 35 U.S.C. § 102(b).

Zond argues GlobalFoundries failed to show Mozgrin Thesis was disseminated or otherwise made available to interested persons as a printed publication more than one year prior to the filing date of the '759 patent. Prelim. Resp. 56–58. Specifically, Zond argues a catalog entry cannot indicate Mozgrin Thesis was available prior to the filing date of the '759 patent. *Id.* at 57 (citing Exhibit 1019).

To qualify as a printed publication within the meaning of § 102, a reference “must have been sufficiently accessible to the public interested in the art.” *In re Cronyn*, 890 F.2d 1158, 1160 (Fed. Cir. 1989) (quoting *Constant v. Adv. Micro–Devices, Inc.*, 848 F.2d 1560, 1568 (Fed.Cir.1988)). “Because there are many ways in which a reference may be disseminated to the interested public, ‘public accessibility’ has been called the touchstone in determining whether a reference constitutes a ‘printed publication’ bar under 35 U.S.C. § 102(b).” *In re Hall*, 781 F.2d 897, 898–99 (Fed. Cir. 1986).

I am not persuaded GlobalFoundries has shown Mozgrin Thesis was publically accessible *more than one year prior to the date of the application* for patent. Specifically, GlobalFoundries relies on a catalog entry from the Russian State Library's catalog of dissertations, which shows an “Imprint” of 1994. Ex. 1019, 2. GlobalFoundries asserts the Russian Library is an institution established to share information it houses with interested persons and the imprint date of 1994 and “Catalog of Dissertations in Russian (since 1995))” on the catalog entry as evidence Mozgrin Thesis is prior art under 35 U.S.C. § 102. Pet. Reply to PO Resp. 21–22. However, nothing in the

catalog entry speaks to the date on which Mozgrin Thesis was incorporated into the Russian State Library's catalog of dissertations or even, that the Russian State Library catalog of dissertations existed at the time of invention. As our reviewing court has stated, "[a]lthough 'evidence establishing a *specific* date of cataloging' was not required in *Hall*, in that case we held that 'competent evidence of the general library practice' of cataloging and shelving established that the thesis became accessible prior to the critical date." *In re Lister* 583 F.3d 1307, 1316 (Fed. Cir. 2009) (vacating and remanding the Board of Patent Appeals and Interferences' decision that a prior art reference registered with the U.S. Copyright Office and included in the Westlaw and Dialog databases was publicly accessible for the purposes of 35 U.S.C. § 102(b)). Here, neither the imprint date nor the labeling indicates the Mozgrin Thesis was publically accessible prior to the critical date. Further, GlobalFoundries "has not identified any evidence of the general practice" of the Russian State Library with regard to catalog updates. *See id.* at 1316–17. Therefore, absent any evidence pertaining to when the Russian State Library received Mozgrin Thesis, when the publicly accessible catalog was available, and what the general practices of the Russian State Library between receipt of a thesis and subsequent incorporation into a publicly accessible catalog are, the presumption Mozgrin Thesis was publicly accessible more than one year prior to the date of the application for patent is pure speculation. *See id.* at 1316.

Furthermore, I respectfully disagree Zond was required to object under 37 C.F.R. § 42.64(b). Significantly, Zond does not contend that Mozgrin Thesis is inadmissible under any Federal Rule of Evidence. Instead, Zond argues Mozgrin Thesis is not prior art under 35 U.S.C. §

102(b) because GlobalFoundries has not shown Mozgrin Thesis was publicly accessible — a challenge to the sufficiency or weight to be given to Mozgrin Thesis. Such argument is not proper in a motion to exclude, which is a challenge to the admissibility of evidence, not a challenge to sufficiency. *See* Office Patent Trial Practice Guide, 77 Fed. Reg. 48,756, 48,767 (August 14, 2012) (stating that a motion to exclude may not be used to challenge the sufficiency of the evidence to prove a particular fact).

Zond properly provided arguments in the preliminary response and response asserting GlobalFoundries has not sufficiently demonstrated that Mozgrin Thesis is prior art under 35 U.S.C. § 102(b). Accordingly, I am not persuaded GlobalFoundries has established, by a preponderance of the evidence, that Mozgrin Thesis is a printed publication under 35 U.S.C. § 102(b). It follows, I am not persuaded claim 44 is unpatentable under § 103(a) as obvious over the combinations of Wang, Kudryavtsev, and Mozgrin Thesis.

IPR2014-01086
Patent 7,147,759 B2

For PETITIONER:

GlobalFoundries:

David Tennant
dtennant@whitecase.com

Dohm Chankong
dohm.chankong@whitecase.com

Gillette:

David Cavanaugh
david.cavanaugh@wilmerhale.com

Larissa B. Park
larissa.park@wilmerhale.com

For PATENT OWNER:

Gregory J. Gonsalves
gonsalves@gonsalveslawfirm.com

Bruce J. Barker
bbarker@chsblaw.com

Tarek Fahmi
tarek.fahmi@ascendlaw.com

CERTIFICATE OF SERVICE

The undersigned hereby certifies that a copy of the foregoing:

PATENT OWNER'S NOTICE OF APPEAL

was served on October 12, 2015, by filing this document through the Patent Review Processing System as well as delivering a copy via EMAIL directed to the attorneys of record for the Petitioner at the following address:

For Petitioner:
GLOBALFOUNDRIES U.S., INC.,
GLOBALFOUNDRIES DRESDEN
MODULE ONE LLC & CO. KG,
GLOBALFOUNDRIES DRESDEN
MODULE
TWO LLC & CO. KG
David M. Tennant
Dohm Chaukong
WHITE & CASE LLP
701 THIRTEENTH STREET, NW
WASHINGTON, DC 20005
dtennant@whitecase.com
dohm.chaukong@whitecase.com

For Petitioner:
THE GILLETTE COMPANY
David L. Cavanaugh, Reg. No. 36,476
Larissa Park, Reg. No. 59,051
Wilmer Cutler Pickering Hale and Dorr
LLP
60 State Street
Boston, MA 02109
Tel: (617) 526-5000
Email:
david.cavanaugh@wilmerhale.com;
larissa.park@wilmerhale.com

The parties have agreed to electronic service in this matter.

An additional copy was served on

Director of the United States Patent and Trademark Office
c/o Office of the General Counsel
Madison Building East, 1 OB20
600 Dulany Street
Alexandria, VA 22314-5793

As required under 37 C.F.R. § 90.2(a).

Respectfully submitted,

Dated: October 12, 2015

/Tarek N. Fahmi/

Tarek N. Fahmi, Reg. No. 41,402

ASCENDA LAW GROUP, PC
333 W. San Carlos St., Suite 200
San Jose, CA 95110
Tel: 866-877-4883
Email: tarek.fahmi@ascendalaw.com