

UNITED STATES PATENT AND TRADEMARK OFFICE

BEFORE THE PATENT TRIAL AND APPEAL BOARD

INTEL CORPORATION,

Petitioner,

v.

R2 SEMICONDUCTOR, INC.,

Patent Owner.

Case IPR2017-01124

U.S. Patent No. 8,233,250

PATENT OWNER R2 SEMICONDUCTOR'S NOTICE OF APPEAL

Director of the United States Patent and Trademark Office
c/o Office of the General Counsel
Madison Building East, Room 10B20
600 Dulany Street
Alexandria, VA 22314-5793

Pursuant to 35 U.S.C. §§ 141(c) and 142 and 37 C.F.R. §§ 90.2(a) and 90.3, Patent Owner R2 Semiconductor, Inc. hereby appeals to the United States Court of Appeals for the Federal Circuit from the Patent Trial and Appeal Board's Final Written Decision, entered on July 31, 2018 (Paper 81) (a copy of which is attached), and from all underlying and related findings, orders, decisions, rulings, and opinions that are adverse to R2 Semiconductor.

For the limited purpose of providing the Director with the information requested in 37 C.F.R. § 90.2(a)(3)(ii), R2 Semiconductor further indicates that the issues on appeal may include, but are not limited to, (1) whether the Board erred in construing the challenged claims of U.S. Patent No. 8,233,250, (2) whether the Board erred in determining the prior art rendered the challenged claims obvious, and (3) whether the Board erred in determining the same prior art rendered R2 Semiconductor's proposed substitute claims obvious.

R2 Semiconductor further reserves the right to challenge any finding or determination supporting or relating to the issues above, and to challenge other issues decided adversely to R2 Semiconductor.

CERTIFICATE OF SERVICE

Pursuant to 37 C.F.R. § 90.2(a)(1), on October 2, 2018 the foregoing Notice of Appeal was filed electronically with the Board in accordance with 37 C.F.R. § 42.6(b)(1), and mailed to the Director via Priority Mail Express in accordance with 37 C.F.R. §§ 1.10 and 104.2 at the following address:

Director of the U.S. Patent and Trademark Office
c/o Office of the General Counsel
P.O. Box 1450
Alexandria, VA 22313-1450

Pursuant to 37 C.F.R. § 90.2(a)(2); Fed. R. App. P. 15; and Fed. Cir. R. 15, 25, and 52, on October 2, 2018 the foregoing Notice of Appeal was electronically filed with the Court of Appeals for the Federal Circuit via CM/ECF with requisite fees paid via pay.gov. Pursuant to Fed. Cir. R. 15(a)(1), one copy of this Notice of Appeal is being filed by hand with the Clerk's Office of the Federal Circuit on October 2, 2018.

Pursuant to 37 C.F.R. § 42.6(e) and the parties' agreement to accept electronic service, on October 2, 2018 the foregoing Notice of Appeal was served via e-mail on the following attorneys for Petitioner:

richard.goldenberg@wilmerhale.com
don.steinberg@wilmerhale.com
joshua.stern@wilmerhale.com
michael.summersgill@wilmerhale.com
theodoros.konstantakopoulos@wilmerhale.com

cosmin.maier@wilmerhale.com
shirley.cantin@wilmerhale.com

DATED: October 2, 2018

Respectfully submitted,

By /s/ James M. Glass
James M. Glass (Reg. No. 46,729)

QUINN EMANUEL URQUHART &
SULLIVAN, LLP
51 Madison Avenue, 22nd Floor
New York, NY 10010
jimglass@quinnemanuel.com

*Attorney for Patent Owner - R2
Semiconductor, Inc.*

UNITED STATES PATENT AND TRADEMARK OFFICE

BEFORE THE PATENT TRIAL AND APPEAL BOARD

INTEL CORPORATION,
Petitioner,

v.

R2 SEMICONDUCTOR, INC.,
Patent Owner.

Case IPR2017-00707
Case IPR2017-00708
Case IPR2017-01124
Patent 8,233,250 B2

Before JAMESON LEE, JEAN R. HOMERE, and JENNIFER S. BISK,
Administrative Patent Judges.

HOMERE, *Administrative Patent Judge.*

FINAL WRITTEN DECISION
Inter Partes Review
35 U.S.C. § 318(a) and 37 C.F.R. § 42.73

Case IPR2017-00707
Case IPR2017-00708
Case IPR2017-01124
Patent 8,233,250 B2

I. INTRODUCTION

Intel Corporation (“Petitioner”) filed three petitions requesting *inter partes* review of U.S. Patent No. 8,233,250 B2 (Ex. 1201, “the ’250 patent”). IPR2017-00707, Paper 4 (“Pet.”); IPR2017-00708, Paper 4 (“’708 Pet.”); IPR2017-01124, Paper 4 (“’1124 Pet.”). In each case we instituted a trial on all challenged claims resulting in review of all claims, 1–31, of the ’250 patent.¹ IPR2017-00707, Paper 10 (“Inst. Dec.”); IPR2017-00708, Paper 10 (“’708 Inst. Dec.”); IPR2017-01124, Paper 10 (“’1124 Inst. Dec.”).

Patent Owner filed a Patent Owner Response in each case. IPR2017-00707, Paper 34 (“PO Resp.”); IPR2017-00708, Paper 34 (“’708 PO Resp.”); IPR2017-01124, Paper 34 (“’1124 PO Resp.”). Similarly, Petitioner filed a Reply in each case. IPR2017-00707, Paper 60 (“Reply”); IPR2017-00708, Paper 58 (“’708 Reply”); IPR2017-01124, Paper 58 (“’1124 Reply”).²

¹ Claims 1–4, 7–9, 13–17, 20–22, and 29 were reviewed in IPR2017-00707, claims 10–12, 23–26, 28, and 31 were reviewed in IPR2017-00708, and claims 5, 6, 18, 19, 27, and 30 were reviewed in IPR2017-01124.

² Both parties also filed in each case a Motion to Exclude Evidence, each of which was fully briefed. IPR2017-00707, Papers 67, 69, 72, 74; IPR2017-00708, Papers 66, 68, 71, 73; IPR2017-01124, Papers 66, 68, 71, 73. Subsequently, the parties withdrew each of these motions. IPR2017-00707, Paper 78; IPR2017-00708, Paper 77; IPR2017-01124, Paper 78.

Case IPR2017-00707
Case IPR2017-00708
Case IPR2017-01124
Patent 8,233,250 B2

In each case, Patent Owner filed a Contingent Motion to Amend, each of which was fully briefed.³ IPR2017-00707, Papers 30, 48, 57, 69; IPR2017-00708, Papers 30, 46, 55, 61, 71; IPR2017-01124, Papers 30, 46, 55, 64.

A transcript of the consolidated oral hearing held on May 1, 2018, has been entered into the record as Paper 79⁴ (“Tr.”).

Because of the substantial overlap in substance, we exercise our discretion and consolidate pursuant to 35 U.S.C. § 315(d), for purposes of this Final Written Decision only, the three proceedings.⁵ For the reasons that follow, Petitioner has demonstrated by a preponderance of the evidence that claims 1–31 of the ’250 patent are unpatentable.

A. Related Matters

The parties indicate that the ’250 patent is involved in *R2 Semiconductor, Inc. v. Intel Corp. et al.*, Civil Action No. 2:16-cv-01011

³ Upon authorization, Patent Owner filed a corrected motion to amend in IPR2017-00708 and Petitioner filed a surreply in all three cases.

⁴ For purposes of this Decision, unless otherwise indicated, a citation to “Paper XX” or “Ex. XXXX” will refer to documents filed in IPR2017-00707. Similarly, “’708 Paper XX” or “’708 Ex. XXXX” will refer to documents filed in IPR2017-00708 and “’1124 Paper XX” or “’1124 Ex. XXXX” will refer to documents filed in IPR2017-01124. Moreover, for efficiency and clarity, unless there is a relevant difference between the cases, we will cite only to documents in IPR2017-00707.

⁵ Should the parties decide to file a rehearing request in response this Decision, they are likewise authorize to file a consolidated request.

Case IPR2017-00707
Case IPR2017-00708
Case IPR2017-01124
Patent 8,233,250 B2

(E.D. Tex.) and *Certain Integrated Circuits with Voltage Regulators and Products Containing Same*, Investigation No. 337-TA-1024 (USITC). Pet. 3; Paper 7, 1–2. Petitioner has also challenged the '250 patent in 3 additional petitions (IPR2017-00705, -00706, and -01123). Pet. 3; Paper 7, 1–2.

B. The '250 Patent

The '250 patent, titled “Over Voltage Protection of Switching Converter,” issued July 31, 2012, from U.S. Patent Application No. 12/646,451. Ex. 1201 at [54], [45], [21]. The '250 patent generally relates to a switched voltage regulator containing regulator circuitry coupled to a voltage spike protection circuitry including a dissipative element and a charge storage circuit such that the spike protection circuitry is able to protect the regulator circuitry against voltage spikes. *Id.* at Abstract. A conventional switched voltage regulator, as described in the '250 patent, is shown in Figure 2 below:

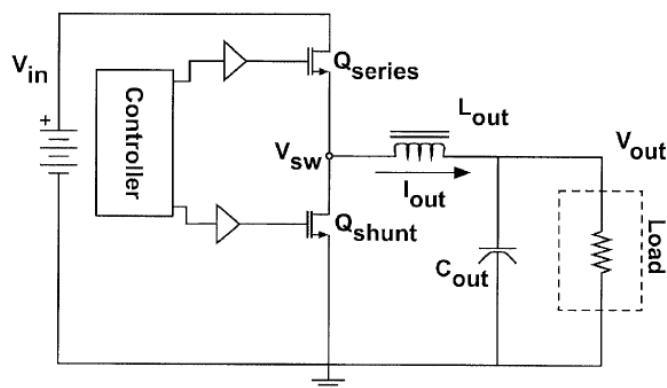

Case IPR2017-00707
Case IPR2017-00708
Case IPR2017-01124
Patent 8,233,250 B2

Figure 2 depicts a conventional switched mode regulator having transistor Q_{series} and transistor Q_{shunt} connected at common switching node V_{sw} .

As shown in Figure 2 above, the '250 patent explains that the transistors are alternately turned on and off such that current I_{out} flows from source terminal V_{in} , through operating transistor $Q_{\text{series}}/Q_{\text{shunt}}$, and through inductor L_{out} to charge up capacitor C_{out} . *Id.* at 2:2–36.⁶ According to the '250 patent, the intermittent switching of the transistors causes rapid switching in the capacitive load and “voltage spikes will occur in any converter that has fast switching transitions” caused by physical inductances present in any realistic packaged device, including the parasitic inductance of the various components of the circuit. *Id.* at 15:42–65, 16:31–37. In addition, according to the Specification, “most switched mode regulators require large valued (and physically large and thick) external inductors and capacitors to operate.” *Id.* at 1:62–64.

⁶ The '250 patent explains that “[w]hen the series switch 301 is rapidly turned off, this parasitic inductor tries to maintain the same output current, causing the voltage V_{hi} to increase rapidly in the absence of any preventive measures . . . the parasitic inductance may interact with parasitic capacitances to form a high-frequency resonant circuit, which will create a persistent ringing condition as a result of the initial rapid voltage transition.” Ex. 1201, 16:5–13.

Case IPR2017-00707
Case IPR2017-00708
Case IPR2017-01124
Patent 8,233,250 B2

The '250 patent describes “a need for a DC-DC converter that is simultaneously compact (including optimally fabrication of all active and passive components on a single semiconductor die), low in cost, and highly efficient even at small ratios of output to supply voltage and low output current.” *Id.* at 6:66–7:3. In addition, according to the '250 patent, “it is desirable to provide spike protection circuitry for the . . . elements of any DC-DC converter employing fast switching transitions.” *Id.* at 16:43–46.

To this end, the '250 patent describes coupling spike protection circuitry to the regulator circuitry (e.g. DC to DC converter) such that the spike protection circuit protects “switching elements of a converter from transient voltages to allow fast low-loss switching operations without degradation of reliability.” *Id.* at 6:66–67, 7:4–7. The voltage regulator with the protection circuit, is shown in Figure 19 below:

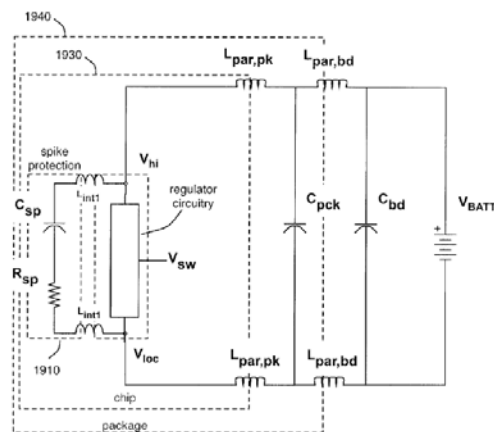

FIGURE 19

Figure 19 shows a voltage regulator including a spike protection circuitry.

Case IPR2017-00707
Case IPR2017-00708
Case IPR2017-01124
Patent 8,233,250 B2

As depicted in Figure 19, the '250 patent describes a regulator/switching circuitry wired to generate a regulated voltage from power supply V_{hi} to power supply V_{loc} , both connected to common node V_{sw} . *Id.* at 7: 11–13. In addition, spike protection circuitry 1910 including resistor R_{sp} and capacitor C_{sp} is coupled to the regulator circuitry as a way to absorb voltage spikes and ringing caused by parasitic inductances L_{int} , $L_{par, pk}$ and $L_{par, bd}$. *Id.* at 18:10–12.⁷ Thus, according to the Specification, the optimal resistance value typically matches closely the characteristic impedance of a lumped-element approximation to a transmission line containing a charge-storage circuit and a parasitic inductance associated the regulator circuit. *Id.* at 17:53–67. The '250 patent states that dissipative element R_{sp} can be realized as polysilicon transistors, thin film metallic resistors, or any other convenient resistive element. *Id.* at 18:59–61.

C. Illustrative Claim

Of the challenged claims, claims 1, 13, 26, 27, 28, 29, 30, and 31 are independent. Claim 1 is illustrative and is reproduced below with disputed limitations emphasized:

⁷ According to the '250 patent, “[t]he ringing might also cause a loss in efficiency if the ringing is poorly timed with the opening or closing of one of the switches. It is[,] therefore, important to incorporate a dissipative element in the spike protection impedance, represented schematically by R_{sp} to minimize undesired ringing in the spike protection circuit.” Ex. 1201, 17:24–29.

Case IPR2017-00707
Case IPR2017-00708
Case IPR2017-01124
Patent 8,233,250 B2

1. A voltage regulator, comprising:
regulator circuitry generating a regulated voltage from a first power supply and a second power supply;
voltage_spike protection circuitry for voltage-spike-protecting the regulator circuitry, comprising a dissipative element and a charge-storage circuit; wherein
a value of resistance of the dissipative element is based on a characteristic impedance of a lumped-element approximation of a transmission line, wherein the transmission line comprises the charge-storage circuit and a parasitic inductance associated with the regulator circuitry.

Ex. 1201, 20:31–42.

D. Asserted Grounds of Unpatentability

Petitioner asserts that (1) claims 1–4, 7–9, 13–17, 20–22, and 29 are unpatentable under § 103(a)⁸ over the combination of Shekhawat⁹ and McMurray,¹⁰ (2) claims 10–12, and 23–26 are unpatentable over the

⁸ Because the claims at issue have a filing date prior to March 16, 2013, the effective date of the Leahy-Smith America Invents Act, Pub. L. No. 112-29, 125 Stat. 284 (2011) (“AIA”), we apply the pre-AIA version of 35 U.S.C. §§ 102, 103, and 112 in this Decision.

⁹ U.S. Patent No. 7,834,597 B1 (“Shekhawat”). IPR2017-00707, Ex. 1206.

¹⁰ McMurray, “*Optimum Snubbers for Power Semiconductors*,” IEEE Transactions on Industry Applications 593, Vol. IA-8, No. 5 (Sept./Oct. 1972) (“McMurray”). Ex. 1203.

Case IPR2017-00707
Case IPR2017-00708
Case IPR2017-01124
Patent 8,233,250 B2

combination of Shekhawat, McMurray, and Ozawa¹¹, (3) claims 28 and 31 are unpatentable over the combination of Shekhawat and Ozawa, and (4) claims 5, 6, 18, 19, 27, and 30 are unpatentable over the combination of Shekhawat, McMurray, and Wong.¹² Pet. 27–72; ’708 Pet. 28–73; ’1124 Pet. 35–75.

II. DISCUSSION

A. *Claim Construction*

In an *inter partes* review, a claim in an unexpired patent shall be given its broadest reasonable construction in light of the specification of the patent in which it appears. 37 C.F.R. § 42.100(b). Under the broadest reasonable construction standard, claim terms are given their ordinary and customary meaning, as would be understood by one of ordinary skill in the art in the context of the entire disclosure. *In re Translogic Tech., Inc.*, 504 F.3d 1249, 1257 (Fed. Cir. 2007). Only terms that are in controversy need to be construed, and then only to the extent necessary to resolve the controversy. *Vivid Techs., Inc. v. Am. Sci. & Eng’g, Inc.*, 200 F.3d 795, 803 (Fed. Cir. 1999).

¹¹ JP. Patent Application No. H10-42573 (“Ozawa”). IPR2017-00708. Ex. 1329.

¹² U.S. Patent No. 5,485,292 (“Wong”) (issued Jan. 16, 1996). IPR2017-01124, Ex. 1530.

Case IPR2017-00707
Case IPR2017-00708
Case IPR2017-01124
Patent 8,233,250 B2

1. “*dissipative element*”

During the pre-institution stage of these proceedings, the parties disagreed regarding the broadest reasonable interpretation of the term “dissipative element.” Pet. 21–27; Prelim. Resp. 21–32. For purposes of the Institution Decision, we agreed with Petitioner and found the term “dissipative element” to be written in means-plus-function format with a function of dissipating energy¹³ and a corresponding structure of a resistor. Inst. Dec. 8–12. For purposes of analyzing patentability of the challenged claims, Patent Owner does not challenge this construction. PO Resp. 16. We, therefore, persuaded by the analysis and construction of the term “dissipative element” from the Institution Decision. Inst. Dec. 8–12.

2. “*voltage spike protection circuitry*”

Patent Owner asserts that the terms “voltage spike protection circuitry for voltage-spike protecting the regulator circuitry”¹⁴ and “voltage-spike-protecting the regulator circuitry with voltage spike protection circuitry”¹⁵

¹³ Both Petitioner and Patent Owner agree that, if construed as requiring means-plus-function treatment, the function of “dissipative element” would be to dissipate energy. Pet. 22, Prelim. Resp. 22.

¹⁴ As recited by independent claims 1 and 27. Ex. 1201, 20:34–35, 22:31–32. Claim 29, similarly recites “voltage spike protection circuitry . . . for voltage-spike-protecting the regulatory circuitry.” *Id.* at 22:63–65.

¹⁵ As recited by independent claims 13, 26, and 30. Ex. 1201, 21:19–20, 22:17–19, 23:11–12.

Case IPR2017-00707
Case IPR2017-00708
Case IPR2017-01124
Patent 8,233,250 B2

“do not have a plain and ordinary meaning.” PO Resp. 17–18; Tr. 33:14–39:23. Accordingly, Patent Owner proposes that to properly capture the scope of the claims as reflected in the Specification, these terms should be construed “to require that the voltage-spike protecting circuitry is on the same integrated circuit as the switches they protect.” PO Resp. 17 n.6.

Arguing that Patent Owner’s narrower construction would “improperly limit the claims to certain embodiments,” Petitioner notes that the claims explicitly define “voltage spike protection circuitry” simply as “circuitry that protects the regulator circuitry from [voltage] spikes.” Reply 3 (citing Ex. 1201, claims 1, 13, 26, 28, 29, and 31). Petitioner adds that none of the claims includes language requiring that voltage spike protection circuitry to be “located on the same integrated circuit” as the regulator circuitry. *Id.* Petitioner, therefore, asserts that the broadest reasonable construction of the term “voltage spike protection circuitry” is coextensive with the definition in the claims—“circuitry that protects the regulator circuitry from [voltage] spikes.” *Id.*

We do not agree with Patent Owner that the broadest reasonable construction of the voltage spike protection circuitry terms, as used in the ’250 patent, limits the voltage spike protection circuitry to the same chip or integrated circuit as the regulator circuitry it is designed to protect.

Patent Owner notes that every disclosed embodiment in the ’250 patent shows both the protection circuitry and the regulator circuitry on the

Case IPR2017-00707
Case IPR2017-00708
Case IPR2017-01124
Patent 8,233,250 B2

same integrated circuit. PO Resp. 18–23. Specifically, Patent Owner points to the embodiments shown in Figures 12, 18, 19, 20, and 22. *Id.* (citing Ex. 1201, Figs. 12, 19, 20, 22, 10:43–46, 16:55–56). Petitioner does not dispute that all the embodiments discussed in the Specification include the voltage spike protection circuitry on the same chip or integrated circuit as the regulator circuitry that it protects. *See* Reply 3–4. Petitioner, however, points out that each of these embodiments is identified as an “example” or an “embodiment.” *Id.* (citing Ex. 1201, 10:42; 16:52, 18:15–16, 19:35, 19:47–48). Based on this language, Petitioner argues that “[i]t is improper to read limitations from the embodiments in the specification into the claims.” *Id.* at 3 (citing *Hill-Rom Servs. v. Stryker Corp.*, 755 F.3d 1367, 1371 (Fed. Cir. 2014)). We agree with Petitioner that it would be improper to read this limitation from the Specification into the claims.

Further, Patent Owner asserts that because the Specification employs very fast switching times using small transistors in the integrated circuits, the circuitries must be located on the same integrated circuit. PO Resp. 18–20, 23–24. Specifically, Patent Owner points to the Specification’s acknowledgement that the consumer market demands creation of the “thinnest and smallest devices possible.” *Id.* at 18 (quoting Ex. 1201, 3:38–40). Patent Owner further notes the disclosure that increased switching frequency and the resulting benefit of lower-valued inductors and capacitors allows for “use of planar geometries that can be integrated on printed-circuit

Case IPR2017-00707
Case IPR2017-00708
Case IPR2017-01124
Patent 8,233,250 B2

boards or fabricated in integrated circuits.” *Id.* at 18–19 (citing Ex. 1201, 3:58–65). According to Patent Owner, it is this act of achieving very fast switching times using advanced transistors on integrated circuits that causes the problem of voltage spiking that the ’250 patent addresses. *Id.* at 19 (citing Ex. 1201, 5:49–50, 5:60–63, 6:56–65). Petitioner does not dispute that the ’250 patent teaches the benefits of small devices and fast switching times, but argues that “these passages say nothing about the *location* of the spike protection circuitry.” Reply 4.

We agree with Patent Owner that the ’250 patent describes the specific problem it is trying to solve in terms that imply single chip implementation. For example, the Specification states that “there exists a need for a DC-DC converter that is simultaneously compact (including optimally fabrication of all active and passive components on a single semiconductor die), low in cost, and highly efficient” that is protected from voltage spikes. Ex. 1201, 6:66–7:7. Dr. Pedram supports this understanding of the ’250 patent, explaining that “[b]y moving the switching transistors on-chip, one can [] ‘reduce[] the overall size of the voltage regulator’—that is, the size of the inductors and capacitors thereon.” Ex. 2208 ¶ 34 (citing Ex. 1201, 6:66–7:3, 1:62–64). We are, nonetheless, not persuaded that such description is sufficient to require Patent Owner’s proposed claim construction of the cited term. The claims are broader and do not recite the specific problem to be solved or the need to be satisfied.

Case IPR2017-00707
Case IPR2017-00708
Case IPR2017-01124
Patent 8,233,250 B2

Additionally, Patent Owner notes that “in the only section dedicated to voltage spike protection,” the two circuits are placed on the same integrated circuit. PO Resp. 19 (quoting Ex. 1201, 15:51–57 (describing “several physical inductances present in any realistic packaged device, including . . . the parasitic inductance of the traces and/or wirebonds connecting the supply leads or bumps to the contact pads *on the integrated circuit containing the converter*”). Similarly, Patent Owner asserts that the ’250 patent “disclaims voltage spike protection circuits that are *not* on the same integrated circuit as the regulatory circuitry.” PO Resp. 24 (quoting Ex. 1201, 16:29–30). Petitioner argues that this is not a *disavowal* of non-integrated-circuit implementation, but instead that it “suggests a potential disadvantage.” Reply 4–5 (citing *Epistar Corp. v. Int’l Trade Comm’n.*, 566 F.3d 1321, 1335 (Fed. Cir. 2009)). Petitioner adds that “in full context, the passage refers only to a specific ‘example,’ not all voltage spike protection circuits.” *Id.* at 4 (citing Ex. 1201, 16:13–30; Ex. 1245 ¶¶ 17–18). We agree with Petitioner that, although it may suggest a potential disadvantage of a non-integrated circuit implementation, this language does not arise to disavowel of non-integrated circuits.

We read the Specification, as a whole, as touting the benefit of voltage spike protection circuitry as being more effective in affecting voltage spikes when implemented on the same chip as the regulator circuitry. Ex. 1201, 16:29–30 (“It should be noted that inclusion of an off-

Case IPR2017-00707
Case IPR2017-00708
Case IPR2017-01124
Patent 8,233,250 B2

chip capacitor does not appreciably affect the size of the spikes.”).

Petitioner’s arguments are not inconsistent with this understanding. Reply 4 (“At most, this passage suggests a potential disadvantage associated with non-integration.”). However, the claims are not limited to the most effective implementation of the voltage spike protection circuitry. Therefore, this particular benefit does not limit the broadest reasonable interpretation of the claims.

In summary, the ’250 patent (1) discloses that the problem to be solved with voltage spiking occurs on compact, fast-switching converters, (2) suggests that implementing the voltage spike protection circuitry on a separate chip would be less effective, and (3) describes multiple embodiments showing only single chip implementation. Although the Specification touts the implementation of the voltage spike protection circuitry and the regulator circuitry on a same chip as being more effective than the implementation on different chips, it does not require a particular implementation. It is not inconsistent with the Specification for the claim term to read on both implementations. Accordingly, we agree with Petitioner that the broadest reasonable interpretation of the voltage spike protection circuitry would encompass its implementation with the regulator circuitry on the same chip, and alternatively on different chips. *See Smith*, 871 F.3d at 1383.

Case IPR2017-00707
Case IPR2017-00708
Case IPR2017-01124
Patent 8,233,250 B2

B. Level of Ordinary Skill in the Art

In determining the level of ordinary skill in the art, various factors may be considered, including the “type of problems encountered in the art; prior art solutions to those problems; rapidity with which innovations are made; sophistication of the technology; and educational level of active workers in the field.” *In re GPAC Inc.*, 57 F.3d 1573, 1579 (Fed. Cir. 1995) (internal quotation and citation omitted).

Petitioner’s Declarant, Dr. Steven B. Leeb, contends that a person having ordinary skill in the art at the time of the invention would have had (1) a Bachelor of Science degree in Electrical Engineering, and (2) two years of graduate work or experience working in the field of power electronics circuit design and chip design or equivalent experience. Ex. 1202 ¶ 57. Further, Patent Owner’s Declarant, Dr. Massoud Pedram, asserts that a person of ordinary skill in the art would have had a Bachelor of Science degree in electrical engineering, and three years of work or research experience in the fields of power electronics or high-speed mixed-signal IC design, or a Master’s degree in electrical engineering and two years of work or research experience in the fields of power electronics or high-speed mixed-signal IC design. Ex. 2001 ¶ 92. Because we do not observe a meaningful difference between the parties’ assessments, and find either assessment to be “consistent with the level of ordinary skill in the art at the time of the invention as reflected in the prior art, we adopt Patent Owner’s

Case IPR2017-00707
Case IPR2017-00708
Case IPR2017-01124
Patent 8,233,250 B2

proposed level. This definition is consistent with the level of ordinary skill reflected in the prior art references of record. *See Okajima v. Bourdeau*, 261 F.3d 1350, 1355 (Fed. Cir. 2001) (the prior art itself may reflect an appropriate level of skill in the art). *In re GPAC Inc.*, 57 F.3d 1573, 1579 (Fed. Cir. 1995); *In re Oelrich*, 579 F.2d 86, 91 (CCPA 1978). For purposes of this decision, we therefore adopt the Patent Owner's proposed level of ordinary skill in the art.

C. Obviousness over Shekhawat and McMurray

Petitioner contends that claims 1–4, 7–9, 13–17, 20–22, and 29 are unpatentable under 35 U.S.C. § 103(a) over the combination of Shekhawat and McMurray. Pet. 29–72. Patent Owner opposes. PO Resp. 26–50. As discussed below, Petitioner has made an adequate showing as to this assertion.

1. Principles of Law

A claim is unpatentable under § 103(a) if the differences between the claimed subject matter and the prior art are such that the subject matter, as a whole, would have been obvious at the time the invention was made to a person having ordinary skill in the art to which said subject matter pertains. *KSR Int'l Co. v. Teleflex Inc.*, 550 U.S. 398, 406 (2007). The question of obviousness is resolved on the basis of underlying factual determinations, including (1) the scope and content of the prior art; (2) any differences between the claimed subject matter and the prior art; (3) the level of skill in

Case IPR2017-00707
Case IPR2017-00708
Case IPR2017-01124
Patent 8,233,250 B2

the art; and (4) when in evidence, objective indicia of non-obviousness (i.e., secondary considerations). *Graham v. John Deere Co.*, 383 U.S. 1, 17–18 (1966). We analyze this asserted ground based on obviousness with the principles identified above in mind.

2. *Overview of Shekhawat*

Shekhawat describes a power converter system for converting an AC input voltage at an input terminal to an AC output voltage at an output terminal. Ex. 1206, 1:60–63. Figure 1 of Shekhawat is reproduced below.

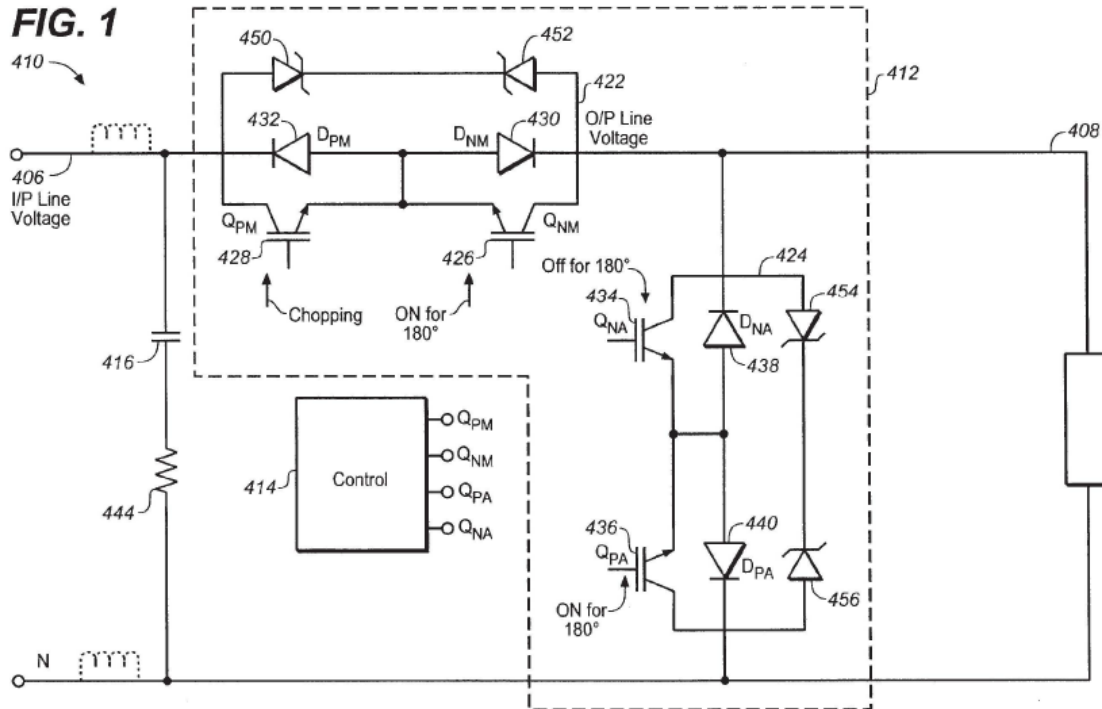

Figure 1 shows a power converter system with an AC/AC chopper circuit.

Figure 1 depicts voltage regulator/power converter 410 containing a snubber circuit¹⁶ (including capacitor 416 and resistor 444) and AC to AC chopper circuit 412. In particular, upon receiving at power terminal 406 an AC input power from a power source, power converter system 410 utilizes chopper 412 coupled to a snubber circuit to reduce voltage spike in the

¹⁶ The function of a snubber circuit is analogous to that of a voltage spike protection circuit. See Ex. 1206, 4:3–6.

Case IPR2017-00707
Case IPR2017-00708
Case IPR2017-01124
Patent 8,233,250 B2

signal, and to subsequently deliver a controlled AC output power to a load at an output terminal 408. Ex. 1206 at 3:55–4:5.

3. Overview of McMurray

McMurray discloses a design procedure for selecting the capacitance and optimum resistance in an RC snubber circuit to limit the peak voltage across a power rectifier or thyristor to absorb energy associated with the recovery current of the device. Ex. 1203, 593–96. An equivalent snubber circuit, as shown in McMurray Figure 1, is depicted below:

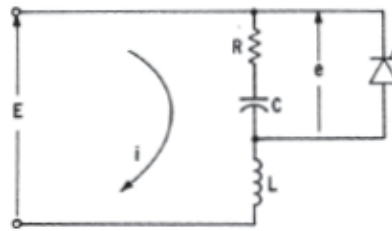

Fig. 1. Equivalent circuit of snubber.

Fig. 1 shows an equivalent snubber circuit.

Figure 1 of McMurray shows “[a] voltage E , applied to a series RCL circuit” where “[t]he voltage e across the snubber resistance and capacitance in series appears as recovery voltage on the semiconductor source.” *Id.* at 593. McMurray also discloses equation 58 for calculating the optimum resistor value based on the damping factor and characteristics of the circuit in which the snubber is to be used such as to limit the resulting voltage spike and rate of rise dv/dt . *Id.* at 594. Equation 58 is reproduced below:

Case IPR2017-00707
Case IPR2017-00708
Case IPR2017-01124
Patent 8,233,250 B2

$$R = 2\zeta_0 \sqrt{\frac{L}{C}} = \frac{2\zeta_0 E\chi_0}{I}. \quad (58)$$

Id. at 594–96. Equation 58, above, shows the value “R” necessary to achieve a particular damping factor, such as 1. *Id.* at 596.

4. *McMurray Qualifies as Prior Art*

Patent Owner argues that “Petitioner and Dr. Leeb provide absolutely no support for their bare conclusory statements that McMurray was published in 1972,” thus, not meeting their burden to show that was publicly available before the critical date. PO Resp. 25–26 (citing Pet. 5; Ex. 1202 ¶ 78).

We do not agree with Patent Owner that Petitioner has not sufficiently shown that McMurray was publicly available before December 23, 2009 (the filing date of the ’250 patent) (“critical date”). McMurray, on its face, indicates that it is an article published in the “September/October 1972” issue of “IEEE Transactions on Industry Applications, Vol. 1A-8, No. 5.” Ex. 1203. Moreover, in the lower left corner of the first page, McMurray notes that it was “approved by the Power Semiconductor Committee of the IEEE Industry Applications Society for presentation at the 1971 IEEE Industry and General Applications Group Annual Meeting, Cleveland, Ohio, October 18–21” and was “released for publication February 23, 1972.” *Id.*

We credit the publication information on the face of McMurray as evidence of its date of publication and public accessibility. As noted in

Case IPR2017-00707
Case IPR2017-00708
Case IPR2017-01124
Patent 8,233,250 B2

previous proceedings, “IEEE is a well-known, reputable compiler and publisher of scientific and technical publications.” *Ericsson Inc. v. Intellectual Ventures I LLC*, IPR2014-00527, Paper 41 at 10–11 (PTAB May 18, 2015). Petitioner also points to several other publications that cited McMurray before the critical date. Petitioner also points to several other publications that cited McMurray before the critical date. Reply 15 (citing Ex. 1207; Ex. 1211). For example, Kassakian, published in 1992 describes McMurray as the “classic” snubber reference. Ex. 1207, 3. Finally, Petitioner provides a declaration of Gerard Grenier, Senior Director of IEEE, which confirms that McMurray was published “on or before September 1972.” Ex. 1251 ¶ 10.

Taken together, the record contains sufficient evidence to show that McMurray was publicly available prior to the ’250 patent’s priority date and, thus, qualifies as prior art. *See Giora George Angres, Ltd. v. Tinny Beauty & Figure, Inc.*, 1997 WL 355479, at *7 (Fed. Cir. June 26, 1997) (unpublished) (finding “no reason to suspect that [a reference published by an established publisher] was not publicly available, including to one skilled in the art” when “no evidence was presented that it was not”) (citing *In re Hall*, 781 F.2d 897, 899 (Fed. Cir. 1986)).

5. *Obviousness Analysis*

Petitioner asserts that the combination of Shekhawat and McMurray discloses the elements of claims 1–4, 7–9, 13–17, 20–22, and 29. Pet. 27–

Case IPR2017-00707
Case IPR2017-00708
Case IPR2017-01124
Patent 8,233,250 B2

71. We begin our analysis with claim 1. We have reviewed the Petition, Patent Owner Response, and Petitioner’s Reply, as well as the relevant evidence discussed in those papers and other record papers. We are persuaded that the record sufficiently establishes Petitioner’s contentions for claims 1–4, 7–9, 13–17, 20–22, and 29.

Petitioner’s Positions

With respect to claim 1, Petitioner relies upon Shekhawat’s “power converter system 410/510” as teaching “a voltage regulator.” Pet. 29–30 (citing Ex. 1206, 1:25–27, 2:62–64, Ex. 1202 ¶¶ 88–90). In particular, Petitioner relies upon Shekhawat’s disclosure of “power converter 410... that ‘receives an AC input power ...and delivers a controlled AC output power to a load at an output terminal’” as teaching “the regulator circuitry generating a regulated voltage from a first power supply and a second power supply.” *Id.* at 30 (citing Ex. 1206, 2:62–3:2, 4:41–49, Ex. 1202 ¶ 91). According to Petitioner, Shekhawat’s node above capacitor 416/516 teaches the first power supply V_{hi} , and the node beneath resistor 444/544 teaches the second power supply V_{loc} . *Id.* at 31 (citing Ex. 1201, 9:10–16). We are persuaded by Petitioner’s showing and find that Shekhawat’s power converter system 410/510 teaches a voltage regulator.

Further, Petitioner relies upon Shekhawat’s “snubber circuit” as teaching the claimed “voltage spike protection circuitry for voltage-spike-protecting the regulator circuitry, comprising a dissipative element and a

Case IPR2017-00707
Case IPR2017-00708
Case IPR2017-01124
Patent 8,233,250 B2

charge-storage element.” *Id.* at 32–37. Petitioner asserts that because Shekhawat’s snubber circuit (including capacitor 416 and resistor 444) will also help reduce voltage spikes across main bi-directional switch 422 when the switch turns off, the snubber circuit protects the regulator circuitry of converter 410/510. *Id.* at 33 (citing Ex. 1202 ¶ 95.) Therefore, Petitioner submits that capacitor 416/516 and resistor 444/544 teach the claimed “charge_storage circuit” and “dissipative element,” respectively. *Id.* at 34 (citing Ex. 1202 ¶ 98). We are persuaded by Petitioner’s showing and find that Shekhawat’s “snubber circuit” teaches the “voltage spike protection circuitry for voltage-spike-protecting the regulator circuitry, comprising a dissipative element and a charge-storage element.”

Additionally, Petitioner relies upon McMurray’s disclosure of a design procedure for selecting the capacitance and optimum resistance for the snubber circuit to limit the peak voltage and absorb energy associated with voltage spikes as teaching “wherein a value of resistance of the dissipative element is based on a characteristic impedance of a lumped-element approximation of a transmission line.” *Id.* at 37–45. In particular, Petitioner relies upon McMurray’s disclosure of equation 58 for determining resistance R of the RC snubber circuit. In particular, Petitioner asserts that the characteristic impedance of a snubber circuit (“ Z_0 ”) equals a portion of equation 58—the expression of the square root of the ratio of the parasitic

Case IPR2017-00707
Case IPR2017-00708
Case IPR2017-01124
Patent 8,233,250 B2

impedance and the capacitance $(L_2/C_s)^{1/2}$.¹⁷ *Id.* at 39–42 (citing Ex. 1202 ¶¶ 110–113; Ex. 1209, 217).¹⁸ Further, Petitioner submits that because the characteristic impedance disclosed in McMurray lumps together all inductances into a single value “L,” and likewise lumps together all capacitances into a single value “C,” one of ordinary skill using McMurray’s technique to select a resistor of Shekhawat’s circuit would have used the lumped element approximations to determine the resistance of the snubber circuit. *Id.* at 42–44 (citing Ex. 1202 ¶¶ 113–117). Additionally, Petitioner asserts that the characteristic impedance equation $Z_0 = (L/C)^{1/2}$ defines the characteristic impedance of a transmission line. *Id.* at 44–45 (citing Ex. 1202 ¶¶ 118–19, Ex. 1209, 217). We are persuaded by Petitioner’s showing and find that McMurray’s disclosure of a design procedure for selecting the capacitance and optimum resistance for the snubber circuit to limit the peak

¹⁷ *See* Pet. 39 (citing Ex. 1202 ¶111; Ex. 1211, 72 and explaining that characteristic impedance Z_0 is provided by $(L_2/C_s)^{1/2}$).

¹⁸ For purposes of this Decision, we credit Petitioner’s explanation, supported by the testimony of Dr. Leeb, that one of ordinary skill reading Shekhawat would have understood that to calculate the value of the snubber resistor in Shekhawat Figures 1 and 3, the ordinarily skilled artisan would calculate the appropriate lumped values of L applicable to the design and the desired damping factor, such that Shekhawat’s circuit could be modeled as McMurray’s Figure 1, and then use McMurray’s teaching to set the values of the snubber resistor and capacitor—*i.e.*, using Equation (58). Pet. 42 (citing Ex. 1202 ¶ 114).

Case IPR2017-00707
Case IPR2017-00708
Case IPR2017-01124
Patent 8,233,250 B2

voltage and absorb energy associated with voltage spikes teaches “wherein a value of resistance of the dissipative element is based on a characteristic impedance of a lumped-element approximation of a transmission line.”

Petitioner relies upon Shekhawat’s snubber capacitor 416/516 in regulator circuit 410/510 as teaching the charge storage capacitor of a transmission line associated with the regulator circuitry. *Id.* at 45–46 (citing Ex. 1202 ¶ 121). Further, Petitioner asserts that McMurray’s disclosure of calculating the amount of inductance L that affects the size of the voltage spikes complements Shekhawat’s snubber circuit such that Shekhawat’s line inductances teaches parasitic inductances of wiring affecting the size of voltage spikes. *Id.* at 46–47 (citing Ex. 1202 ¶ 122). Accordingly, Petitioner submits that the ordinarily skilled artisan would include Shekhawat’s parasitic inductance in the L of McMurray’s equivalent circuit to determine the optimum resistance R . *Id.* at 47. We are persuaded that a person having ordinary skill in the art would have found it obvious to combine the teachings of Shekhawat and McMurray because we agree with Petitioner that McMurray’s technique for calculating the inductance L affecting the voltage spikes would complement Shekhawat’s snubber circuit so as to determine an optimal value for the resistance R .

Independent claims 1, 13 and 29 are substantially similar. Specifically, claims 1 and 13 have substantially similar limitations, but differ in that claim 1 is written in device form, “a voltage regulator” and claim 13

Case IPR2017-00707
Case IPR2017-00708
Case IPR2017-01124
Patent 8,233,250 B2

is written in method form, “a method of generating a regulated voltage.” Ex. 1201, 20:31–42, 21:15–28. The differences between these two claims do not affect our patentability analysis.

Claim 29, differs from claim 1 in that it specifically recites the regulator circuitry

generating a regulated voltage from a first power supply and a second power supply, the regulator circuitry comprising a series switch element and a shunt switch element connected between the first power supply and the second power supply, and a switching controller operative to generate a switching voltage through closing and opening of a series switch and a shunt switch as controlled by a series switch control signal and a shunt switch control signal

Ex. 1301, 22:54–62. For reasons similar to those discussed, above, regarding claim 1, we find that Shekhawat discloses this limitation. *See* Pet. 60–69 (citing Ex. 1206, Fig. 3, ¶¶ 57, 60, 62; Ex. 1202 ¶¶ 150–152, Ex. 1202 ¶¶ 147–163). Patent Owner does not address these limitations of claim 29.

In addition, Petitioner has shown, persuasively, that a person of ordinary skill in the art would have been motivated to combine the teachings of McMurray’s equation for the resistance value with the circuitry taught by Shekhawat. We have considered the entirety of the evidence submitted by the parties, both for and against obviousness. We determine that Petitioner has shown, by a preponderance of the evidence that independent claims 1, 13, and 29 of the ’250 patent are unpatentable over the combined teachings

Case IPR2017-00707
Case IPR2017-00708
Case IPR2017-01124
Patent 8,233,250 B2

of Shekhawat and McMurray.

We have considered Petitioner’s argument and supporting evidence, including Dr. Leeb’s testimony regarding dependent claims 2–4, 7–9, 14–17, and 20–22 of the ’250 patent. Pet. 48–71; Ex. 1202 ¶¶ 129–144, 150–153, 169–172. We find that Petitioner has shown that the combined teachings of Shekhawat and McMurray teach the limitations of the cited claims.

Likewise, Petitioner has provided sufficiently “articulated reasoning,” with “rational underpinning” and evidentiary support, to combine the teachings of these references to predictably yield the recited systems and methods. *See KSR*, 550 U.S. at 418 (quoting *Kahn*, 441 F.3d at 988). Patent Owner does not explicitly address the additional limitations of the dependent claims.

Specifically, claims 2 and 14 depend from independent claims 1 and claim 13, respectively, and add “wherein the parasitic inductance add “wherein the dissipative element damps ringing of a power supply to the regulator circuitry.” Ex. 1201, 20:51–53, 21:38–41. Claim 16 depends from independent claim 13, and adds limitations substantively similar to those in dependent claims 4 and 17—“wherein a value of resistance of the dissipative element is selected to critically damp ringing of a power supply to circuitry that generates the regulated voltage.” Ex. 1201, 21:35–38. For the reasons discussed with regard to the term “voltage spike protection circuitry” (Section II.C.5), we find Petitioner has shown the limitations of claims 2, 4, 14, and 17 are taught by the combined teachings of Shekhawat

Case IPR2017-00707
Case IPR2017-00708
Case IPR2017-01124
Patent 8,233,250 B2

and McMurray. *See* Pet. 48–51, 58–59; Ex. 1202 ¶¶ 124–127, 143.

Claims 3 and 14 depend from claim 1 and claim 15, respectively, and add “wherein the parasitic inductance comprises an inductance associated with a power supply of the regulator circuitry.” Ex. 1201, 20:48–50, 21:32–34. We are persuaded by Petitioner’s analysis and find that Petitioner has shown this limitation is disclosed by the combined teachings of Shekhawat and McMurray. *See* Pet. 51, 52, 59; Ex. 1202 ¶¶ 128, 129, 144.

Claim 7 depends from independent claim 1, and adds “further comprising at least one switching element, Ex. 1201, 20:63–64. Claim 20 depends from independent claim 13, and adds—“further comprising generating the regulated voltage through controlled closing and opening of at least one switch element.” *Id.* at 21:50–52. We are persuaded by Petitioner’s analysis and find Petitioner has shown, by a preponderance of the evidence, that this limitation would have been obvious over the combination of Shekhawat and McMurray. *See* Pet. 53, 54, 69, 70; Ex. 1202 ¶¶ 131, 132, 164, 165.

Claim 8 depends from claim 7, and adds “wherein the dissipative element suppresses ringing of the regulated voltage during a switching period of the at least one switching element.” Ex. 1201, 20:65–67. Claim 21 depends from claim 20, and adds—“wherein a value of resistance of the dissipative element is selected to suppress ringing of the regulated voltage during a switching period of the at least one switching element.” *Id.* at

Case IPR2017-00707
Case IPR2017-00708
Case IPR2017-01124
Patent 8,233,250 B2

21:53–56. We persuaded by Petitioner’s analysis and find Petitioner has shown, by a preponderance of the evidence, that this limitation would have been obvious over the combination of Shekhawat and McMurray. *See* Pet. 54–56, 70; Ex. 1202 ¶¶ 133–136, 167.

Claim 9 depends from claim 7, and adds “wherein a value of resistance of the dissipative element is selected to prevent degradation of the at least one switching element.” Ex. 1201, 21:1–3. Claim 22 depends from claim 21, and adds —“wherein at least one characteristic of the dissipative element is additionally selected to prevent degradation of the at least one switch element.” *Id.* at 21:57–59. We persuaded by Petitioner’s analysis and find Petitioner has shown, by a preponderance of the evidence, that this limitation would have been obvious over the combination of Shekhawat and McMurray. *See* Pet. 56–57, 70–71; Ex. 1202 ¶¶ 137, 168.

Patent Owner’s Positions

Patent Owner argues that the challenged claims would not have been obvious over the combination of Shekhawat and McMurray for the following reasons: (i) neither Shekhawat nor McMurray discloses the “value of the resistance of the dissipative element is [based on / matches]” as recited in independent claims 1, 13 or 29 (PO Resp. 26–32); (ii) neither Shekhawat nor McMurray discloses the “transmission line comprises...a parasitic inductance associated with the regulatory circuit,” as recited in independent claims 1, 13, and 29 (*id.* at 32–33); and (iii) neither Shekhawat nor

Case IPR2017-00707
Case IPR2017-00708
Case IPR2017-01124
Patent 8,233,250 B2

McMurray discloses the “voltage spike protection circuitry” as recited in independent claims 1, 13 or 29 (*id.* at 33–39). Further, Patent Owner argues that there is insufficient motivation to combine Shekhawat with McMurray. In particular, Patent Owner argues that Shekhawat and McMurray address different problems (*id.* at 42–43); they disclose incompatible solutions and the combination would not yield predictable results (*id.* at 43–44); and their proposed combination is not supported with a sufficient motivation (*id.* at 44–46). Additionally, Patent Owner argues considerations of non-obviousness including a long-felt-need (*id.* at 46–48), a teaching away in the prior art (*id.* at 48–49), and industry skepticism (*id.* at 49). We address each argument in turn.

a. The “value of the resistance of the dissipative element is based on matches”

Patent Owner argues that neither Shekhawat nor McMurray teaches or suggests “a value of the resistance of the dissipative element is based on the characteristic impedance of a lumped_element approximation of a transmission line...” as recited in independent claims 1, 13, and 29. PO Resp. 26. In particular, Patent Owner asserts that although McMurray discloses an RLC snubber along with an equation for calculating the value of resistance R as the square root of L/C , such equation does not disclose a transmission line or calculating the characteristic impedance thereof, much less lumped elements approximations of transmission lines, as required by

Case IPR2017-00707
Case IPR2017-00708
Case IPR2017-01124
Patent 8,233,250 B2

the claim. *Id.* at 27–29. According to Patent Owner, McMurray simply discloses resistors, capacitors, and inductors connected by wires, and is silent regarding transmission lines. *Id.* at 29–30 (citing Ex. 2210, 79:12–21). In addition, Patent Owner contends that because the Ramo reference is not asserted as a reference in the Petition, Dr. Leeb improperly relied upon Ramo to conclude that the use of square root of L/C in McMurray’s equations refers to the characteristic impedance. *Id.* at 30 (citing Ex. 1209, Ex. 1202 ¶ 123).¹⁹ Furthermore, Patent Owner argues that characteristic impedance is not an equation; instead it can be described as “the termination impedance of a uniform lossless line, so that it didn’t give any reflections or appeared to be infinitely long.” *Id.* (citing Ex. 2210, 124:2–5). Patent Owner asserts that the square root of L/C can be used to estimate an ideal type of lossless transmission line, but it is not necessarily descriptive of a transmission line in all instances. *Id.* at 31. Additionally, Patent Owner submits that despite any similarity between McMurray’s equations and those

¹⁹ Patent Owner argues that “Ramo is not asserted as anticipatory art or in combination with McMurray in the Petition, so it is improper for Dr. Leeb to rely” on it for the equation of characteristic impedance. PO Resp. 30. However, we find that Ramo is properly used as corroborating evidence of what a person of ordinary skill in the art would have known. *Ariosa Diagnostics v. Verinata Health, Inc.*, 805 F.3d 1359, 1365 (Fed. Cir. 2015) (“Art can legitimately serve to document the knowledge that skilled artisans would bring to bear in reading the prior art identified as producing obviousness.”).

Case IPR2017-00707
Case IPR2017-00708
Case IPR2017-01124
Patent 8,233,250 B2

recited in the claims, McMurray is not only devoid of any teaching pertaining to the characteristic impedance of a lumped element approximation of a transmission line, it also teaches away from transmission lines. *Id.*

Petitioner counters that the combination of Shekhawat and McMurray teaches the claimed transmission line. Reply 5. In particular, Petitioner avers that Shekhawat discloses a circuit to which a person of ordinary skill in the art (POSA) would apply the McMurray resistance equation, which has a transmission line including a “charge storage circuit” (i.e., a capacitor) and “parasitic inductance associated with the regulatory circuitry” (i.e., wire inductances) as corroborated by the Ramo reference. *Id.* at 5–6 (citing Ex. 1202, 123, 1244 ¶¶ 20–21). According to Petitioner, as acknowledged by Patent Owner and its expert witness, because a transmission line is simply a conductor or any medium designed to carry electrical signals from a source point to a destination point, McMurray’s Figure 1 shows an equivalent circuit of such a line. *Id.* at 6 (citing Ex. 2208 ¶¶ 110–111).

We agree with Petitioner. At the outset, Patent Owner’s conclusory argument alleging McMurray teaches away from transmission lines is not persuasive because Patent Owner fails to show any portion of McMurray that criticizes, discredits, or otherwise discourages the use of transmission lines. As fully discussed *infra*, the record before us supports that McMurray teaches the claimed transmission lines. Further, we agree with Petitioner

Case IPR2017-00707
Case IPR2017-00708
Case IPR2017-01124
Patent 8,233,250 B2

that McMurray's disclosure of $(L/C)^{1/2}$ is the characteristic impedance, Z_0 of a transmission line based upon which snubber resistance R is calculated. Pet. 41–44 (citing Ex. 1202 ¶ 113). In particular, we agree with Petitioner that the $(L_2/C_s)^{1/2}$ expression of equation 58 equals McMurray's characteristic impedance (Z_0) and includes approximations of lump values of L and C pertaining to all relevant material inductances and capacitances in the snubber circuit. *Id.* at 43–44. Likewise, we agree with Petitioner that McMurray's characteristic impedance is that of a transmission line. *Id.* at 45 (citing Ex. 1202 ¶ 118; Ex. 1209, 217). As corroborated by the Ramo textbook, and acknowledged by Patent Owner, we agree with Petitioner that a person of ordinary skill in the art would readily appreciate that the square root of L/C disclosed in the McMurray equation is that of a transmission line (albeit a lossless line as argued by Patent Owner). Reply 7–8 (citing Ex. 1207, 689; Ex. 1209, 45; Ex. 1244 ¶ 25). As correctly noted by Petitioner, McMurray teaches reducing a complex circuit to an equivalent circuit thereby approximating lumped RLC elements of an ideal circuit to a non-ideal equivalent circuit wherein signals are transmitted from one source point to a destination point (i.e. parasitic inductance in a transmission line). *Id.* at 8.

Therefore, based on the evidence before us, we are persuaded that “a value of [the] resistance of the dissipative element is based on the characteristic impedance of a lumped element approximation of a

Case IPR2017-00707
Case IPR2017-00708
Case IPR2017-01124
Patent 8,233,250 B2

transmission line . . . ,” as recited in independent claims 1,13, and 29, is taught by the combined teachings of Shekhawat and McMurray. *See e.g.* Ex. 1211, 12 (referring to McMurray’s paper and using its disclosed equation to “demonstrate the general behavior of an RC snubber”).

b. The Transmission Line Comprising . . . a parasitic inductance associated with the regulatory circuit

Patent Owner argues that Even if McMurray discloses a transmission line, it is a lossless one, as opposed to a transmission line type associated with a parasitic inductance. PO Resp. 33 (Ex. 1203.) According to Patent Owner, McMurray’s disclosure of a lossless transmission line (with zero reflection) in an ideal circuit teaches away from the claimed parasitic inductance. *Id.* (citing Ex. 2213).

This argument is not persuasive. Other than alleging that McMurray discusses ideal circuits, Patent Owner does not contend that any portion of McMurray criticizes, discredits, or otherwise discourages the use of parasitic inductance in determining the proper resistance value for Shekhawat’s snubber circuit. Moreover, nothing in McMurray’s disclosure that “a power converter can usually be reduced to an equivalent circuit” limits its teaching to *only* ideal circuits.²⁰ Ex. 1203, 593. To the contrary, the evidence

²⁰ Even Patent Owner, at oral hearing, doubted that McMurray is limited to ideal circuits by stating “I think McMurray talks about an ideal transient, I don’t know that it’s saying that the circuit is necessarily ideal.” Tr. 63:10–12.

Case IPR2017-00707
Case IPR2017-00708
Case IPR2017-01124
Patent 8,233,250 B2

supports a finding that a person of ordinary skill in the art would understand that McMurray applies to non-ideal circuits, which, as previously discussed, would have indicated to a person of ordinary skill that the circuit contains parasitic inductances. *See* Pet. 46–47; Reply 9. For example, Dr. Leeb testifies that McMurray’s discussion of reducing circuits to equivalents “applies to actual as well as ‘ideal’ circuits and discloses taking a ‘lumped element approximation’ according to the claims.” Ex. 1244 ¶ 26. And, other than pointing to McMurray’s “idealized” Figure 2, Dr. Pedram’s testimony to the contrary is unsupported. *See* Ex. 2208 ¶¶ 100. In fact, Mr. Fisher, President and Chief Executive Officer of Patent Owner R2 Semi, agreed that “a lumped element approximation of a transmission line” may be used “to generate an equivalent circuit that’s simplified and could be used for purposes of simulation.” Ex. 1247, 75:19–76:2.

Further, we agree with Petitioner that Shekhawat also discloses the transmission line. Reply 5–6. As acknowledged by Patent Owner’s Expert, a transmission line is any medium (e.g., a conductor) designed to carry an electrical signal. Ex. 2208 ¶¶ 110–111; Ex. 1246, 90:1–4). Because Shekhawat discloses a capacitor connected to a resistor and an inductor through connection lines so as to transmit electrical signals from a source point to a destination point, we agree with Petitioner that Shekhawat teaches the transmission lines with associated parasitic inductance. Ex. 1206, Figures 1 and 3; Reply 6. Furthermore, because McMurray discloses

Case IPR2017-00707
Case IPR2017-00708
Case IPR2017-01124
Patent 8,233,250 B2

converting a complex circuit into an equivalent simple RLC circuit, we agree with Petitioner that McMurray teaches converting an ideal complex circuit with lossless transmission lines to a non-ideal simple circuit with transmission lines including parasitic inductance. Ex. 1203, Figure 1, Reply 8–9. In light of the foregoing discussion, we agree with Petitioner that the combination of Shekhawat and McMurray teaches “a value of the resistance of the dissipative element is based on a characteristic impedance of a lumped element approximation of a transmission line, wherein the transmission line comprises the charge-storage circuit and a parasitic inductance associated with the regulator circuitry [the regulator circuitry / generation of the regulated voltage],” as required by independent claims 1, 13, and 29.

c. The “voltage spike protection circuitry”

Patent Owner argues that the combination of Shekhawat and McMurray does not teach that the voltage spike protection circuitry is on the same integrated circuit as the regulator circuitry, as required by Patent Owner’s construction. PO Resp. 33–34. According to Patent Owner, McMurray is directed to the recovery of voltage transient in a semiconductor-rectifier diode or thyristor device, and teaches away from integrated circuits. *Id.* at 34. Further, Patent Owner argues that although Shekhawat discloses a passage indicating that power converter systems can be implemented on a single semiconductor die/chip, Patent Owner contends that the passage in question is rather aspirational because it does not provide

Case IPR2017-00707
Case IPR2017-00708
Case IPR2017-01124
Patent 8,233,250 B2

information as to how such implementation of the voltage regulator circuitry and the spike protection circuitry can be achieved. *Id.* at 37 (citing Ex. 1202 ¶¶ 115–127; 1206, 8:17–22). Instead, Patent Owner argues Shekhawat teaches away from integrating the voltage regulator circuitry and the snubber circuit onto a single die because thyristors, and SCRs are discrete devices are not readily suitable for implementation in integrated devices. *Id.* at 37–40 (citing Ex. 2208 ¶¶ 110–113).

These arguments are not persuasive because they are not commensurate with the scope of the claim. Consistent with our claim construction above, because claim 1 does not recite implementing the voltage regulator on an integrated circuit, it also does not require implementing the voltage spike protector circuitry and the regulator circuitry on the same integrated circuit. Further, as correctly argued by Petitioner (Reply 10–11), because Shekhawat expressly contemplates implementing the disclosed invention in MOS technology (i.e. integrated circuit), the ordinarily skilled artisan would know how to implement the voltage regulator and the snubber circuit on a single die. Ex 1244 ¶ 33. Patent Owner’s teaching away argument is similarly unavailing because Shekhawat prescribes using MOSFETs (not IGBTs and SCRs) as transistors in integrated circuits. Ex. 1206, 3:30–34, 5:2–6. Additionally, we agree with Petitioner that McMurray is relied upon to help determine the optimum value of the snubber circuit resistance so as to reduce voltage spikes in

Case IPR2017-00707
Case IPR2017-00708
Case IPR2017-01124
Patent 8,233,250 B2

Shekhawat's voltage regulator. *Id.* at 12. Accordingly, we agree with Petitioner that the teachings of Shekhawat and McMurray disclose the voltage protection circuitry.

Regarding claims 2, 13, and 14, Patent Owner reiterates substantially the same arguments discussed above with regard to claim 1. PO Resp. 40–41. As discussed above, we do not agree with Patent Owner's characterization of the prior art because the combination of McMurray and Shekhawat teaches the snubber circuit and the regulator circuitry being implemented on a single die. Accordingly, we agree with Petitioner that the proposed combination of Shekhawat and McMurray teaches the disputed limitations.

d. Motivation to Combine Technologies of Shekhawat and McMurray to Yield a Predictable Result

Patent Owner argues that Shekhawat and McMurray relate to different technologies. PO Resp. 42. In particular, Patent Owner argues that Shekhawat relates to a power converter system for AC voltage regulation for converting an AC input voltage to an AC output voltage provided to a terminal load, whereas McMurray relates to power rectifiers such as silicon controlled rectifiers (SCFs), which are a subset of thyristors. *Id.* 41–44 (citing Ex. 1206, 1:16–18, Ex. 2208 ¶ 117). Further, Patent Owner argues that the cited references are directed to incompatible solutions that would not yield predictable results. *Id.* at 43. According to Patent Owner, Shekhawat

Case IPR2017-00707
Case IPR2017-00708
Case IPR2017-01124
Patent 8,233,250 B2

is concerned with using AC-to-AC voltage regulators to address the problem of bi-directional switches implemented with SCRs, whereas McMurray addresses the reverse recovery problem in power rectifiers, which Shahawat does not regard. *Id.* Consequently, Patent Owner argues that the references provide incompatible solutions, and the combination thereof would not produce a predictable result. *Id.* at 43–44.

We do not agree with Patent Owner’s characterization of the prior art. As noted above, Shekhawat is concerned with using a snubber circuit to reduce voltage spikes in a voltage regulator. Ex. 1206 at 3:55–4:5. McMurray discloses a design procedure for selecting the capacitance and optimum resistance in an RC snubber circuit to limit the peak voltage across a power rectifier or thyristor to absorb energy associated with the recovery current of the device. Ex. 1203, 593–96. The evidence supports a finding that a person of ordinary skill in the art would have been motivated to combine McMurray’s equations for a resistance value with Shekhawat’s circuit. The evidence shows that a person of ordinary skill in the art would have understood McMurray to be a general reference on snubbers, not specifically related only to power rectifier circuitry. *See* Ex. 1207, 3 (“McMurray’s paper . . . is the classic snubber reference,” including “techniques for designing conventional RLC snubbers.”); Ex. 1211, 12 (referring to McMurray’s paper and using its disclosed equation to “demonstrate the general behavior of an RC snubber”). This same evidence

Case IPR2017-00707
Case IPR2017-00708
Case IPR2017-01124
Patent 8,233,250 B2

shows that although McMurray discusses a particular problem to be solved, its teachings are not restricted to that problem. Instead a person of ordinary skill would understand McMurray's teachings to be generally relevant to snubbers and the problem of voltage spike protection. *See Cross Med. Products v. Medtronic Sofamor Danek Inc.*, 424 F.3d 1293, 1323 (Fed. Cir. 2005) (“One of ordinary skill in the art need not see the identical problem addressed in a prior art reference to be motivated to apply its teachings.”).

Moreover, we agree with Petitioner that Patent Owner's argument regarding incompatible solutions and unpredictable results assumes a requirement of bodily incorporation of McMurray's power rectifiers into Shekhawat circuitry. *See Reply 13–14*. This, however, is not consistent with Petitioner's assertions. Instead, the Petition's proposed modification is aimed at extending, to Shekhawat's circuitry, McMurray's technique for calculating an optimum value of the snubber circuit resistance as a way to reduce voltage spikes in Shekhawat's voltage regulator. *See Pet. 28–32*. We, therefore, agree with Petitioner, as corroborated by Dr. Leeb, that because both Shekhawat and McMurray are concerned with the same issue of setting the value of the snubber resistance, they are directed to the same technology and same problem. *Reply 13–14; Ex. 1244 ¶ 39*. We further agree with Petitioner that because Shekhawat and McMurray disclose known prior art mechanisms that perform known functions to predictably result in a

Case IPR2017-00707
Case IPR2017-00708
Case IPR2017-01124
Patent 8,233,250 B2

snubber circuit that effectively reduces voltage spikes in a regulator, the references are properly combined. *Id.* at 14.

Additionally, regarding Patent Owner’s allegation that there is insufficient motivation to support the proposed combination, Petitioner has provided the following rationales for combining Shekhawat with McMurray:

A person of ordinary skill reading Shekhawat would have known to set the value of Shekhawat’s snubber resistor to achieve the goal of Shekhawat’s snubber circuit of “reduc[ing] voltage spikes,” which can “produce a lot of electromagnetic interference (EMI) and distortion and, even worse, can cause the transistors in the bi-directional switch to avalanche, ultimately destroying them.”

Pet. 27 (citing Ex. 1206, 4:21–24, 1:50–53; Ex. 1202 ¶ 85.)

McMurray complements Shekhawat—its explanation of a well-known method of setting a resistor value is generally applicable to snubber circuits and would have been readily applied by a person of skill implementing the circuit disclosed by Shekhawat.

Id. at 28 (citing Ex. 1206, 4:21–24, Ex. 1202 ¶ 86).

A person of ordinary skill reading Shekhawat would have been familiar with design analysis for snubber circuits and would have used knowledge made common decades earlier by references like McMurray to design the component values for the given application to reduce voltage spikes in the circuit.

Id. at 29 (citing Ex. 1202 ¶ 87.)

Case IPR2017-00707
Case IPR2017-00708
Case IPR2017-01124
Patent 8,233,250 B2

We credit Dr. Leeb’s testimony. Ex. 1202 ¶¶ 85–87. Accordingly, the evidence discussed above supports a finding that a person of ordinary skill in the art would have had a reason to apply McMurray’s equation for resistance value to Shekhawat’s circuit. . See *KSR*, 550 U.S. at 398, 418 (citing *In re Kahn*, 441 F.3d 977, 988 (Fed. Cir. 2006)).

e. Objective Indicia of Non-Obviousness

The Supreme Court explained that various factors “may also serve to ‘guard against slipping into use of hindsight,’ and to resist the temptation to read into the prior art the teachings of the invention in issue.” *Graham v. John Deere Co.*, 383 U.S. at 35 (citation omitted). These factors are commonly known as secondary considerations or objective indicia of non-obviousness. Secondary considerations are an important part of the obviousness analysis, evidence of which we must consider. See *Transocean Offshore Deepwater Drilling, Inc. v. Maersk Drilling USA, Inc.*, 699 F.3d 1340, 1349 (Fed. Cir. 2012).

Patent Owner introduces evidence that it contends shows secondary considerations of non-obviousness. PO Resp. 46–49. Specifically, Patent Owner groups its evidence into three categories, long-felt need, teaching away, and industry skepticism. *Id.* We have considered all of Patent Owner’s evidence of secondary considerations. Upon consideration, however, we conclude that in each category, Patent Owner’s evidence is entitled to minimal weight because Patent Owner has not sufficiently shown

Case IPR2017-00707
Case IPR2017-00708
Case IPR2017-01124
Patent 8,233,250 B2

a nexus between the evidence and the merits of the challenged claims of the '250 patent. *Wyers v. Master Lock Co.*, 616 F.3d 1231, 1246 (Fed. Cir. 2010) (“For objective [evidence of secondary considerations] to be accorded substantial weight, its proponent must establish a nexus between the evidence and the merits of the claimed invention.”).

In addition, Patent Owner has not provided sufficient supporting or contextual evidence for us to properly evaluate the probative value of Patent Owner’s theories. As explained below, for each category, Patent Owner’s arguments relating to these objective indicia of non-obviousness are conclusory and not fully developed or explained. On balance, we view Patent Owner’s evidence as providing very minimal, if any, support for nonobviousness. These findings and conclusions regarding Patent Owner’s objective indicia of nonobviousness apply to all of the claims and grounds for unpatentability.

Long-Felt but Unresolved Need

“Evidence of a long-felt but unresolved need can weigh in favor of the non-obviousness of an invention because it is reasonable to infer the need would not have persisted had the solution been obvious.” *Apple Inc. v. Samsung Elecs. Co.*, 839 F.3d 1034, 1056 (Fed. Cir. 2016).

Patent Owner asserts that, at the time of the '250 patent, “there existed a need for an integrated voltage regulator that was low in cost, and highly efficient.” PO Resp. 46–47. To support this contention, Patent Owner

Case IPR2017-00707
Case IPR2017-00708
Case IPR2017-01124
Patent 8,233,250 B2

points to a discussion in the '250 patent itself, which explains that current voltage regulators could not meet industry expectations and that prior attempt to solve the problem were not commercially viable because of large voltage swings. *Id.* (citing Ex. 1201, 1:39–61, 5:33–6:54). In addition, Patent Owner points to International Patent Application No. WO 2013/048475 filed September 30, 2011, and owned by Petitioner. *Id.* at 47 (citing Ex. 2211). According to Patent Owner, in this application, Petitioner “acknowledged that it was facing the same problems in 2011 that were acknowledged in the '250 patent.” *Id.* (quoting Ex. 2211, 2). Patent Owner also notes that in granting a claim from a related European Patent Application, “the Examiner noted that the prior art of record did not disclose ‘wherein values of a resistor and capacitor of the resistor capacitor damping network are determined by a parasitic inductance of the input voltage.’” *Id.* at 48 (quoting Ex. 2211, 60).

Patent Owner’s evidence is insufficient to show a long-felt but unresolved need in several respects. First, Patent Owner “provided no evidence to explain how long this need was felt, or when the problem first arose.” *Perfect Web Techs., Inc. v. InfoUSA, Inc.*, 587 F.3d 1324, 1332 (Fed. Cir. 2009); *see also Iron Grip Barbell Co. v. USA Sports, Inc.*, 392 F.3d 1317, 1325 (Fed.Cir.2004) (“Absent a showing of long-felt need or the failure of others, the mere passage of time without the claimed invention is not evidence of nonobviousness.”). Second, we are not persuaded that

Case IPR2017-00707
Case IPR2017-00708
Case IPR2017-01124
Patent 8,233,250 B2

Patent Owner's evidence, including assertions from its own patent application and Petitioner's disclaimer of application 2013/048475 confirming Petitioner's view that the application is not patentable (*see* Reply 17 (citing Ex. 1254)), is sufficient to show that the alleged need was unsolved at the time of the invention. *Monarch Knitting Mach. v. Sulzer Morat GmbH*, 139 F.3d 877, 884 (Fed.Cir.1998) ("The relevant secondary consideration is 'long-felt but unsolved need,' not long-felt need in isolation."); *see also Kahn*, 441 F.3d at 990 ("[O]ur precedent requires that the applicant submit actual evidence of long-felt need, as opposed to argument."). We agree with Petitioner that the mere filing of applications (by Patent Owner or Petitioner) directed towards allegedly similar technology does not constitute evidence of a "long-felt need" absent a showing of nexus between the alleged long-felt need and the claims being challenged. Reply 17. Further, because Patent Owner has not pointed to testimony from its expert to identify, specifically, how long the alleged need was felt, and any prior unsuccessful attempts by others to provide a solution to the alleged problem, the weight of the evidence does not favor Patent Owner's position. These application statements merely are assertions not supported by underlying evidence.

Finally, for evidence of long-felt but unsolved need to be probative of nonobviousness, a patentee must demonstrate a nexus between that evidence and the patented features. *Apple Inc. v. Samsung Elecs. Co.*, 816 F.3d 788,

Case IPR2017-00707
Case IPR2017-00708
Case IPR2017-01124
Patent 8,233,250 B2

798 (Fed. Cir. 2016), (*other grounds vacated on rehearing en banc by 839 F.3d 1034 (Fed. Cir. 2016)*). Nothing in the claims requires that the invention be “low in cost” or “efficient” and Patent Owner provides no supporting data to show that the invention actually reduced cost or efficiency of integrated voltage regulators.

We, therefore, determine that Patent Owner’s evidence proposed to show a long-felt, but unsatisfied, need, is entitled to little weight.

Teaching Away

Whether prior art teaches away from the claimed invention may show objective indicia of a secondary consideration of nonobviousness. *See Ecolochem, Inc. v. S. Cal. Edison Co.*, 227 F.3d 1361, 1380 (Fed. Cir. 2000).

Patent Owner asserts that “International Patent Publication WO 2008/011530 . . . was filed on July 19, 2017 and actively teaches away from using a resistor and capacitors for spike protection” because it “expressly criticizes that technique for ‘increas[ing] components and size of the controller as well as decreas[ing] its efficiency.’” PO Resp. 48–49 (quoting Ex. 1214,²¹ 5:8–28, 3:49–64). Patent Owner provides no other explanation or evidence of how this disclosure affects our obviousness analysis.

²¹ Exhibit 1214 contains an office action for U.S. Application No. 12/646,451, and appears unrelated to WO 2008/011,530. PO Resp. 48–49; Ex. 1214. The record, therefore, does not show that WO 2008/011530 states what Patent Owner represents that it describes.

Case IPR2017-00707
Case IPR2017-00708
Case IPR2017-01124
Patent 8,233,250 B2

Petitioner argues that the language pointed to by Patent Owner “merely acknowledges consequences of a particular approach,” but does not teach away from the claimed invention. Reply 18.

As discussed above with respect to an alleged long-felt need, Patent Owner has not made the requisite showing of nexus. Nothing in the claims requires that the invention be “efficient.” Moreover, we agree with Petitioner that the quoted language does not teach away from the claimed invention. Patent Owner does not explain how this language would have taught to a person of ordinary skill that the claimed invention would be unlikely to work. *In re Gurley*, 27 F.3d 551, 553, (Fed. Cir. 1994) (“[I]n general, a reference will teach away if it suggests that the line of development flowing from the reference’s disclosure is unlikely to be productive of the result sought by the applicant.”).

We, therefore, determine that Patent Owner’s evidence does not show the prior art teaches away from the claimed invention.

Industry Skepticism

Under the title “Consideration of Non-Obviousness,” Patent Owner includes in its Response a short section titled “Industry Skepticism.” PO Resp. 84. Patent Owner asserts that “[w]hen R2 first promoted its commercial products embodying the ’250 patent to other companies in the industry, many in the industry were not expecting it to achieve its performance goals, including Intel Mobile Corporation, International

Case IPR2017-00707
Case IPR2017-00708
Case IPR2017-01124
Patent 8,233,250 B2

Rectifier, TriQuint Semiconductor and Motorola Mobility.” PO Resp. 49. To support this assertion, Patent Owner proffers an email from an employee of International Rectifier to several employees of Patent Owner stating “[f]or our market and applications in DC:DC it is necessary to convert 12V down to .8 V or so with very high efficiency at high frequency” and “[w]e are hopeful but skeptical of claims for 10’s of MHz switching in this space; please prepare for an eager audience but one prepared to ask some technical questions to validate basis for performance claims.” *Id.* (citing Ex. 2214, 2). Patent Owner provides no other explanation or evidence of how this email shows general industry skepticism of the challenged claims or connects to the identified industry members.

As discussed above with respect to the other two categories, Patent Owner has not made the requisite showing of nexus for industry skepticism. Nothing in the claims requires “10s of MHz switching” or “very high efficiency.” Additionally, we have not been directed to evidence tending to show that a Patent Owner’s product embodying the claimed invention actually achieved “10s of MHz switching” or “very high efficiency.” On this record, if there was industry skepticism, the skepticism may have been directed to non-claimed aspects of the product. In any event, a single email from a single person working in the field, at least in the context of this case, is insufficient to establish meaningful “industry skepticism.”

Case IPR2017-00707
Case IPR2017-00708
Case IPR2017-01124
Patent 8,233,250 B2

We, therefore, determine that Patent Owner's evidence proffered to show industry skepticism is entitled to little weight and does not support a finding of nonobviousness.

6. *Conclusion*

We have considered the entirety of the evidence submitted by the parties, both for and against obviousness, and determine that Petitioner has shown, by a preponderance of the evidence, that claims 1–4, 7–9, 13–17, 20–22, and 29 of the '250 patent would have been obvious over the combined teachings of Shekhawat and McMurray.

D. *Obviousness over Shekhawat, McMurray, and Ozawa*

Petitioner asserts that claims 10–12, and 23–26 are unpatentable under 35 U.S.C. § 103(a) over the combined teachings of Shekhawat, McMurray, and Ozawa. '708 Pet. 28–70. Further, Petitioner asserts that claims 28 and 31 are unpatentable over the combination Shekhawat and Ozawa. *Id.* at 70–72. Patent Owner disagrees. '708 PO Resp. 28–55. As discussed below, Petitioner has made a persuasive showing as to these assertions.

1. *Overview of Ozawa*

As depicted in Figure 11 below, Ozawa discloses a delta configured snubber circuit for a power converter segmented into a plurality of blocks (11a–c), (12a–c) arranged in parallel, wherein each power converter block contains its own delta snubber circuitry to facilitate the power handling capacity thereof. '708 Ex. 1329 ¶ 18.

(FIG. 11)

(FIG. 11)

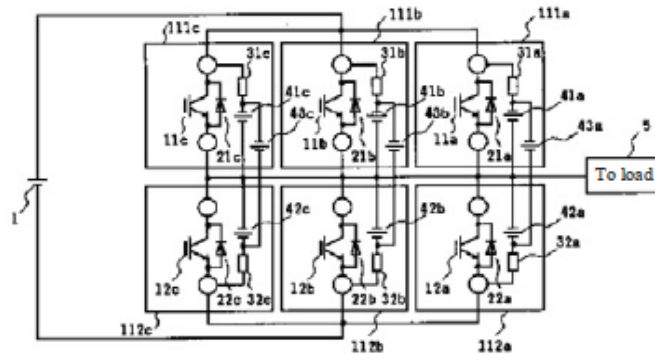

Figure 11 shows a voltage converter segmented into multiple blocks each having its own snubber circuit.

2. Obviousness Analysis

As discussed in section II.C.5 above, Petitioner accounts for all of the claim limitations required by independent claims 1, 13, and 29. Further, Petitioner accounts for dependent claims 10–12 and 23–25, as well as independent claim 26 along with a reason to combine the teachings of Shekhawat, McMurray, and Ozawa, and citing Dr. Leeb's Declaration for support. '708 Pet. 28–70; '708 Ex. 1302. Patent Owner disagrees. '708 PO Resp. 28–55. Likewise, Petitioner accounts for all the claims limitations required by claims 28 and 31 and provides a reason to combine Shekhawat and Ozawa. '708 Pet. 70–72. Patent Owner disagrees. '708 PO Resp. 42–

Case IPR2017-00707
Case IPR2017-00708
Case IPR2017-01124
Patent 8,233,250 B2

43. We have considered Petitioner’s arguments and supporting evidence, including Dr. Leeb’s testimony, regarding claims 10–12, 23–26, 28 and 31 of the ’250 patent. We find that Petitioner has shown that all the limitations of claims 10–12, 23–26, 28, and 31, in the manner as required by those claims, are taught by the combination of Shekhawat, McMurray, and Ozawa.

As an initial matter, we note Patent Owner reiterates substantially the same arguments considered and rejected above in Section II.C.5 with respect to the patentability of independent claims 1, 13, and 29. ’708 PO Resp. 28–55. Accordingly, for the reasons discussed above, we find that the combination of Shekhawat and McMurray teaches the limitations of independent claims 1, 13, and 29. We thus find that Petitioner has shown that the limitations of claims 1, 13, and 29 are disclosed by the combination of Shekhawat and McMurray. ’708 Pet. 32–51; ’Ex. 1302 ¶¶ 75–83, 91–94).

As noted in Section II.C5 above, independent claims 26 and 29 are substantively similar,²² except that claim 26 is written in method form, “a method of generating a regulated voltage,” and claim 29 written in device form, “a voltage regulator.” Ex. 1201, 22:3–27, and 22:53–23:6.

Claim 26 also differs from claims 1 and 13 in that it more specifically recites the functioning of the regulator circuitry. *Id.* For example, claim 26 recites the regulator circuitry

²² See *supra* note 26.

Case IPR2017-00707
Case IPR2017-00708
Case IPR2017-01124
Patent 8,233,250 B2

generating the regulated voltage through controlled closing and opening of a series switch element and shunt switch element, the series switch element being connected between a first voltage supply and a common node, and the shunt switch being connected between the common node and a second supply voltage

Id. at 22:5–11. Claim 26 also recites two periods, during the first of which the series switch element is closed, and during the second, the shunt switch element is closed. *Id.* at 22:12–13. Finally, claim 26 recites

wherein the series switch element and the shunt switch element form switching blocks, and each switching block comprises a plurality of switching block segments, and further comprising voltage-spike-protecting the regulator circuitry with voltage spike protection circuitry, wherein the voltage spike protection circuitry comprising a dissipative element and a charge-storage circuit;

Id. at 22:14–22.

We find that Shekhawat discloses regulator circuitry generating the regulated voltage through controlled opening and closing of series and shunt switch elements. *See* '708 Pet. 65–66 (citing '708 Ex. 1306, Fig. 3; '708Ex. 1302 ¶¶ 163–164). Moreover, Shekhawat discloses a series switching element connected at one end to the first voltage supply, the shunt switching element connected to the second voltage supply, and connected to each other at a common node. *Id.* at 67 (citing '708 Ex. 1302 ¶ 164; '708Ex.1306, Figs. 1 and 3). We also conclude that a person of ordinary skill would have understood that “to generate a regulated voltage using a switching regulator,

Case IPR2017-00707
Case IPR2017-00708
Case IPR2017-01124
Patent 8,233,250 B2

controlled opening and closing would involve sending a control signal to close the series switch element (transistor) for a period of time and then sending a control signal to close the shunt switch element (transistor) for a second period of time,” and Shekhawat discloses that the control system turns the transistors on and off. *Id.* (citing ’708Ex. 1306, Fig. 1; ’708 Ex. 1302 ¶¶ 164–165). Therefore, we are persuaded that the evidence before us shows that Shekhawat teaches the switching elements of the regulator circuitry recited by claim 26. *See also id.* 68–69 (citing ’708 Ex. 1306, Fig. 3; ’708 Ex. 1102 ¶¶ 166–169). Patent Owner does not address these limitations of claim 26.

Dependent claim 10 depends from claims and adds “wherein the at least one switching element comprises a plurality of switching block segments.” Ex. 1201, 21:4–6. Dependent claim 23 depends from claim 21, and adds “wherein at least one switch element is segmented into a plurality of switching block segments.” Ex. 1201, 21:60–62. *Id.* at 21:60–62. We are persuaded by Petitioner’s analysis and find Petitioner has shown that this limitation is disclosed by the combined teachings of Shekhawat, McMurray, and Ozawa. *See* ’708 Pet. 51–53, 64, 65; ’708 Ex. 1302 ¶¶ 129, 133–136, 158.

Dependent claims 11 and 24 depend from claims 10 and 23 respectively, and add “wherein at least a portion of the voltage spike protection circuitry is located between the plurality of switching block

Case IPR2017-00707
Case IPR2017-00708
Case IPR2017-01124
Patent 8,233,250 B2

segments.” Ex. 1201, 21:7–9, 21:63–65. We find a person of ordinary skill would apply Ozawa’s teaching of replicating elements of a circuit to Shekhawat’s voltage regulator circuitry so as to arrange the divided snubber circuits close to the respective switch segments that they protect. 708 Ex. 1329, Fig. 10, Ex. 1206, ¶ 76, Fig. 4; *see also* Figs. 7, 9. We, therefore, are persuaded by Petitioner’s analysis and find Petitioner has shown that this limitation is disclosed by the combined teachings of Shekhawat, McMurray, and Ozawa. *See* ’708 Pet. 52–53, 65; ’708 Ex. 1302 ¶¶ 137–140, 159.

Dependent claim 12 depends from claim 10 and adds “wherein charge-storage circuit comprises charge-storage circuit segments, and each charge-storage circuit segment of the spike protection circuit is physically closer to the switching block segment it protects than any other switching block segment.” Ex. 1201, 21:10–14. Dependent claim 25 depends from claim 23, and adds “wherein each charge-storage circuit segment of the spike protection circuit is physically closer to the switching block segment it protects than any other switching block segment.” *Id.* at 21:66–22:2. Petitioner relies upon Ozawa for its teaching of a well-known technique for increasing the power handling capacity of a circuit by dividing elements of a circuitry into multiple blocks. ’708 Pet. 30, 51–56 (citing ’708 Ex. 1329 ¶¶ 6, 18). Consequently Petitioner concludes that the ordinarily-skilled artisan would have been motivated to increase current control and capacity of the

Case IPR2017-00707
Case IPR2017-00708
Case IPR2017-01124
Patent 8,233,250 B2

snubber circuit in Shekhawat by using Ozawa's technique of splitting the chopper block/charge storage circuit into multiple segments so as to arrange each capacitor physically closer to a segment that it protects. *Id.* at 30–31, 56 (citing '708 Ex. 1302 ¶ 141). According to Petitioner, in light of Ozawa's teaching that the increased distance increases inductance and surge voltage, it would have been obvious to the ordinarily-skilled artisan to arrange the snubbers closer to the switches they protect because it would have helped reduce the parasitic inductance thereby reducing voltage spikes. *Id.* at 57, n. 15 (citing '708 Ex. 1302 ¶ 142 n. 18). In particular, Petitioner asserts the following:

[A] person of ordinary skill would have understood that proximity of the snubber and switching device can reduce inductance and would have placed each snubber (and its associated capacitor) close to the switching block segment it protects. One of ordinary skill would have understood from those teachings alone that placing a snubber further from the switch it protects than some other switch would increase the parasitic inductance between the snubber and the switch it protects and thereby increase the surge voltage. Accordingly, it would have been obvious to one of ordinary skill that each snubber circuit should be placed more closely to the switch it protects than any other switch.

Id. at 57 (citing '708 Ex. 1302 ¶142.)

Patent Owner asserts that while Petitioner concedes that the combination of Shekhawat and McMurray does not teach the physically closer limitation of claims 12 and 25, Petitioner identifies “nothing to

Case IPR2017-00707
Case IPR2017-00708
Case IPR2017-01124
Patent 8,233,250 B2

suggest that a POSITA would have recognized the benefits of this configuration in 2009...and relies entirely on the conclusory statements of its expert.” ’708 PO Resp. 42. We do not agree with this characterization of the record. As noted above, Petitioner relies upon Ozawa’s teaching of dividing the snubber circuit into a plurality of segments, and placing each segment physically closer to the switch that it protects so as to modify to the effectiveness of Shekhawat’s snubber circuit in protecting the regulator. Reply 13 (citing ’708 Ex. 1341 ¶ 36).

Further, Patent Owner alleges that there is insufficient motivation to combine Ozawa with Shekhawat because, unlike Shekhawat, Ozawa is concerned with the problem of a delta-configured snubber capacitor comprising numerous parts by making it more compact and economical so as to perform snubbing more effectively. PO Resp. 48–51 (citing ’708 Ex.1328 ¶¶ 1, 40, ’708 Ex. 2308 ¶¶ 131-32, 134–35, and 137). These arguments are misplaced. Patent Owner’s argument regarding incompatible solutions and unpredictable results erroneously assumes a requirement of bodily incorporation of Ozawa’s snubber circuitry into Shekhawat voltage regulator circuitry. Instead, Petitioner’s proposed modification is aimed at extending, to Shekhawat’s circuitry, Ozawa’s teaching of using the well-known segmentation technique to effectively reduce line inductance in the regulator, so as to reduce voltage spikes in the regulator. ’708 Pet. 55 (citing ’708 Ex. 1306 1:47–53, 2:57–59), ’708 Reply 12–13. We are persuaded by

Case IPR2017-00707
Case IPR2017-00708
Case IPR2017-01124
Patent 8,233,250 B2

Petitioner's assertion that Shekhawat's snubber circuit would benefit from Ozawa's segmentation technique as it would help minimize the inductance of the wiring in the regulator by keeping each snubber close to its associated switch, thereby effectively reducing voltage spikes in the regulator. *Id.* at 55–57 (citing '708 Ex. 1302 ¶¶ 140–42).

Accordingly, on the record before us, we are persuaded that Petitioner has provided an articulated reasoning with rational underpinning to support the legal conclusion of obviousness. *See KSR.*, 550 U.S. at 418 (citing *Kahn*, 441 F.3d at 977, 988). We thus agree with Petitioner that the combination of Shekhawat, McMurray, and Ozawa is sufficiently supported with proper motivation.

We have considered the entirety of the evidence, both for and against obviousness, and determine that Petitioner has shown, by a preponderance of the evidence, that claims 12 and 25 of the '250 patent are unpatentable as obvious over the combined teachings of Shekhawat, McMurray, and Ozawa.

Petitioner asserts that independent claims 28 and 31 would have been obvious under 35 U.S.C. § 103(a) as obvious over the combined teachings of Shekhawat and Ozawa. '708 Pet. 70–72. Patent Owner disagrees. '708 PO Resp. 43. We have considered Petitioner's argument and supporting evidence, including Dr. Leeb's testimony, regarding claims 28 and 31 of the '250 patent. '708 Pet. 70–72; '708 Ex. 1302 ¶¶ 171–180. We find that Petitioner has shown that all the limitations of independent claims 28 and 31

Case IPR2017-00707
Case IPR2017-00708
Case IPR2017-01124
Patent 8,233,250 B2

are taught by the combination of Shekhawat and Ozawa. Other than merely reciting the limitations of the cited claims, and alleging that the cited combination does not teach the cited limitation, which is insufficient, Patent Owner does not specifically address the limitations of claims 28 and 31.

Claims 28 and 31 recite a “voltage regulator” and a “method of generating a regulated voltage” comprising “regulator circuitry generating a regulated voltage.” Ex. 1201, 22:39–41; 24:1–4. For the reasons discussed above (Sections II.C.5 and II.D.2) with respect to independent claims 1, 13, 26, and 29, which contain substantially similar limitations, we find that Shekhawat teaches or suggests these limitations. *See* ’708 Pet. 70–71; ’708 Ex. 1302 ¶¶ 171,176.

Claims 28 and 31 recite “voltage spike protection circuitry” comprising “a dissipative element and a charge-storage circuit.” Ex. 1201, 22:42–44, 24:5–8. For the reasons discussed above (Section II.C.5) with respect to independent claims 1, 13, 26, and 29, which contain substantially similar limitations, we find that Shekhawat teaches or suggests these limitations. *See* ’708 Pet. 71–72; ’708 Ex. 1302 ¶¶ 173, 178.

Claims 28 and 31 recite “at least one switching element, wherein the at least one switching element comprises a plurality of switching block segments.” Ex. 1201, 22:45–47, 24:9–11. For the reasons discussed above (Section II.C.5) with respect to dependent claims 10 and 23, which contain substantially similar limitations, we persuaded by Petitioner’s analysis and

Case IPR2017-00707
Case IPR2017-00708
Case IPR2017-01124
Patent 8,233,250 B2

find that Shekhawat teaches ests these limitations. *See* '708 Pet. 71–72; '708 Ex. 1302 ¶¶ 174, 179.

Finally, claims 28 and 31 recite “the charge-storage circuit comprises charge-storage circuit segments, and each charge-storage circuit segment of the spike protection circuit is physically closer to the switching block segment it protects than any other switching block segment.” Ex. 1201, 22:48–52, 24:12–16. For the reasons discussed above (Section II.C.5) with respect to dependent claims 12 and 25, which contain substantially similar limitations, we persuaded by Petitioner’s analysis and find that the combination of Shekhawat and Ozawa teaches these limitations. *See* '708 Pet. 71–72; '708 Ex. 1302 ¶¶ 175, 180.

We determine that Petitioner has shown, by a preponderance of the evidence that claims 28 and 31 of the '250 patent would have been obvious over the combined teachings of Shekhawat and Ozawa.

3. Conclusion

We have considered the entirety of the evidence, both for and against obviousness, and determine that Petitioner has shown, by a preponderance of the evidence, that claims 10–12, 23–26, and 31 of the '250 patent would have been obvious over the combination of Shekhawat, McMurray, and Ozawa.

Case IPR2017-00707
Case IPR2017-00708
Case IPR2017-01124
Patent 8,233,250 B2

E. *Obviousness over Shekhawat, McMurray, and Wong*

Petitioner asserts that claims 5, 6, 18, 19, 27, and 30 are unpatentable under 35 U.S.C. § 103(a) over the combined teachings of Shekhawat, McMurray, and Wong. '1124 Pet. 35–73. Patent Owner disagrees. '1124 PO Resp. 27–54. As discussed in detail below, we find that Petitioner has shown, by a preponderance of the evidence, that all the limitations of claims 5, 6, 18, 19, 27, and 30, in the arrangement as required by these claims, are taught by the combined teachings of Shekhawat, McMurray, and Wong.

1. *Overview of Wong*

As depicted in Figure 2 below, Wong discloses a capacitor containing a plurality of silicon layers separated by an oxide. In particular, the capacitor 40 includes silicon substrate 42 with an overlying field oxide 44 above which are formed polysilicon regions 46, 52 insulated by gate oxide regions 48 and by inter-electrode oxide regions 50. Ex. 1530, 3:25–43.

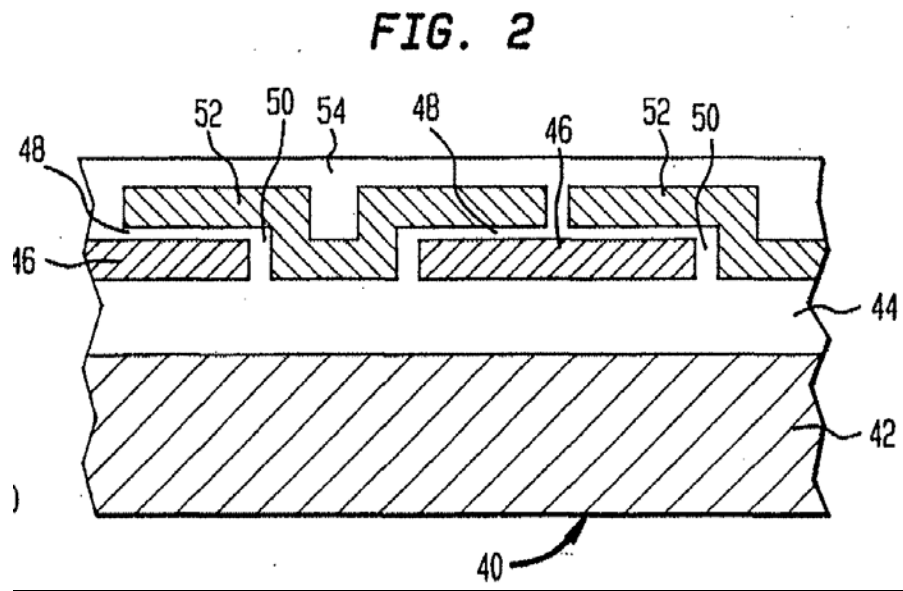

Figure 2 shows an integrated polysilicon capacitor for use in a capacitor divider network.

2. *Obviousness Analysis*

Petitioner provides explanations to account for all of the claim limitations required by claims 5, 6, 18, 19, 27, and 30 and a reason to combine the teachings of Shekhawat, McMurray, and Wong, and citing Dr. Leeb's Declaration for support. '1124 Pet. 35-74; '1124 Ex. 1502. Patent Owner disagrees. '1124 PO Resp. 27-54. We have considered Petitioner's arguments and supporting evidence, including Dr. Leeb's testimony, regarding claims 5, 6, 18, 19, 27, and 30 of the '250 patent. As discussed below, we find that Petitioner has shown that the combination of Shekhawat, McMurray, and Wong teaches all the limitations of claims 5, 6,

Case IPR2017-00707
Case IPR2017-00708
Case IPR2017-01124
Patent 8,233,250 B2

18, 19, 27, and 30, and has provided sufficiently “articulated reasoning,” with “rational underpinning” and evidentiary support, to combine the teachings of these references to predictably yield the recited systems and methods. *See KSR*, 550 U.S. at 418 (quoting *Kahn*, 441 F.3d at 988).

For the reasons discussed above in Section II.C.5, Petitioner has shown by a preponderance of the evidence that claims 1 and 13 would have been obvious over a combination of Shekhawat and McMurray.

Claim 5 depends from claim 1, and recites “further comprising at least one MOS structure, wherein the MOS structure comprises the charge-storage circuit and at least a portion of the dissipative element.” Ex. 1201, 20:54–57. Claim 18 depends from claim 13, and recites “wherein at least one MOS structure includes the charge-storage circuit and at least a portion of the dissipative element.” *Id.* at 21:42–44.

Petitioner relies on Wong for the additional limitations of claims 5 and 18. ’1124 Pet. 71; ’1124 Ex. 1502 ¶¶ 160–162. Further, Petitioner relies upon Wong for its teaching of using standard MOS technology to separate the multiple layers of a polysilicon capacitor by oxide. ’1124 Pet. 59–74 (citing ’1124 Ex. 1530, 3:30–41). Petitioner then concludes that the ordinarily skilled artisan would have looked to Wong’s teaching of using a MOS capacitor to implement Shekhawat’s power converter/snubber capacitor on a single chip, and thereby simplify fabrication, reduce space, and reduce cost. *Id.* at 60–61, 63 (citing ’1124 Ex. 1502 ¶ 147). Petitioner

Case IPR2017-00707
Case IPR2017-00708
Case IPR2017-01124
Patent 8,233,250 B2

further concludes the ordinarily-skilled artisan would have used Wong's high-voltage capacitor in Shekhawat so that the snubber capacitor could tolerate the operating voltages of Shekhawat's power converter. *Id.* at 62 (citing '1124 Ex. 1502 ¶ 145).

Patent Owner reiterates substantially the same arguments considered and rejected above in Section II.C.5 with respect to the validity of claim 1. '1124 PO Resp. 27–46, 50–54. Accordingly, for the reasons discussed above (Sections II.C.5) with respect to independent claim 1, we find that the combination of Shekhawat and McMurray teaches the limitations of the cited claims. Further, Patent Owner asserts that significant differences teach away from combining Shekhawat and Wong. '1124 PO Resp. 46. According to Patent Owner, there is insufficient motivation to combine Shekhawat and Wong because they are directed to incongruent technologies. *Id.* In particular, Patent Owner argues Shekhawat relates to high voltage, low frequency applications suitable for alternating current (AC) voltage regulation using an auxiliary bi-directional switch, and it is intended to reduce voltage spikes in an AC-to-AC power converter system. *Id.* at 46–48 (citing '1124 Ex. 2508 ¶¶ 125, 128). In contrast, Patent Owner argues that Wong is directed to a high voltage differential sensor using an input attenuator with a capacitor divider network, which is compact in construction, economical in manufacture, and capable of withstanding high input voltages without breakdown. *Id.* at 49 (citing '1124 Ex. 1530 1:9–11,

Case IPR2017-00707
Case IPR2017-00708
Case IPR2017-01124
Patent 8,233,250 B2

27–35). Therefore, Patent Owner submits that a POSITA would not look to Wong’s patent on sensors to be informed on Shekhawat’s voltage regulation design. *Id.* at 50 (citing Ex. 2508 ¶¶ 132, 137). We do not agree with Patent Owner’s characterization of Wong. Patent Owner’s argument regarding incompatible solutions and unpredictable results assumes a requirement of bodily incorporation of Wong’s differential sensors into Shekhawat circuitry. Instead, Petitioner’s proposed modification is aimed at extending to Shekhawat’s circuitry, Wong’s teaching of using MOS technology to fabricate series capacitors. *See* ’1124 Pet. 60–61, 63 (citing ’1124 Ex. 1502 ¶ 147). We agree with Petitioner that a person of ordinary skill in the art would have found it obvious to apply Wong’s teaching of using MOS technology to fabricate the capacitors in Shekhawat’s circuitry so as to yield a more compact, simple and economical AC-to-AC power converter. *Id.* Accordingly, on the record before us, we are persuaded that Petitioner has provided an articulated reasoning with rational underpinning to support the legal conclusion of obviousness. *See KSR*, 550 U.S. at 418 (citing *Kahn*, 441 F.3d at 977, 988). We thus agree with Petitioner that the combination of Shekhawat, McMurray, and Wong is sufficiently supported by a proper motivation to combine.

We are persuaded by Petitioner’s analysis, and find Petitioner has shown, by a preponderance of the evidence, that this limitation would have been obvious over the combination of Shekhawat, McMurray and Wong.

Case IPR2017-00707
Case IPR2017-00708
Case IPR2017-01124
Patent 8,233,250 B2

Claims 6 and 19 depend from claims 1 and 13 respectively and recite “wherein [the] charge-storage circuit comprises a plurality of MOS capacitors connected in series, wherein a voltage across each MOS capacitor is maintained below a predetermined threshold as determined by a maximum allowed DC voltage of each MOS capacitor.” Ex. 1201, 20:58–62, 21:45–49. We agree with Petitioner’s analysis and find Petitioner has shown, by a preponderance of the evidence, that this limitation would have been obvious over the combination of Shekhawat, McMurray, and Wong. *See* ’1124 Pet. 65–69, 71–72; ’1124 Ex. 1502 ¶¶ 150–156, 162. Patent Owner does not explicitly address the additional limitation of claims 6 and 19.

Claims 27 and 30 are independent and recite a ““voltage regulator” and “[a] method of generating a regulated voltage” comprising “regulator circuitry generating a regulated voltage,” respectively. Ex. 1201, 22:28–30; 23:7–10. For the reasons discussed above (Sections II.C.5 and II.D.2) with respect to independent claims 1, 13, 26, and 29, which contain substantially similar limitations, we find that the combination of Shekhawat and McMurray teaches these limitations. *See* ’1124 Pet. 72, 73; ’1124 Ex. 1502 ¶¶ 164, 165, 168, 169.

Claims 27 and 30 recite “voltage spike protection circuitry” comprising “a dissipative element and a charge-storage circuit.” Ex. 1201, 22:31–32, 23:11–14. For the reasons discussed above (Section II.C.5 and II.D.2) with respect to independent claims 1, 13, 26, and 29, which contain

Case IPR2017-00707
Case IPR2017-00708
Case IPR2017-01124
Patent 8,233,250 B2

substantially similar limitations, we find that the combination of Shekhawat and McMurray teaches these limitations. *See* '1124 Pet. 72–73; '1124 Ex. 1502 ¶¶ 166, 170.

Finally, claims 27 and 30 recite “the charge-storage circuit comprises a plurality of MOS capacitors connected in series, wherein a voltage across each MOS capacitor is maintained below a predetermined threshold as determined by a maximum allowed DC voltage of each MOS capacitor.” Ex. 1201, 22:34–38, 23:14–18. For the reasons discussed above with respect to dependent claims 6 and 19, which contain substantially similar limitations, we are persuaded by Petitioner’s analysis and find that these limitations are taught by the combined teachings of Shekhawat, McMurray, and Wong. *See* '1124 Pet. 72–74; '1124 Ex. 1402 ¶¶ 167, 171.

3. *Conclusion*

We have considered the entirety of the evidence, both for and against obviousness, and determine that Petitioner has shown, by a preponderance of the evidence, that claims 5, 6, 18, 19, 27, and 30 of the '250 patent would have been obvious over the combination of Shekhawat, McMurray, and Wong.

III. PATENT OWNER’S MOTION TO AMEND

We have concluded that claims 1–31 of the '250 patent are unpatentable. Therefore, we address Patent Owner’s contingent motion to substitute claims 32–62 for claims 1–31. Paper 30 (“MTA”); '708 Paper 30

Case IPR2017-00707
Case IPR2017-00708
Case IPR2017-01124
Patent 8,233,250 B2

(“’708 MTA”); ’1124 Paper 30 (“’1124 MTA”). The parties submitted full briefing on Patent Owner’s Motion to Amend in all three cases. Paper 48 (“Opp. MTA”); Paper 57 (“Reply MTA”); Paper 66 (“Sur-Reply MTA”); ’708 Paper 46 (“’708 Opp. MTA”); ’708 Paper 55 (“’708 Reply MTA”); ’708 Paper 65 (“’708 Sur-Reply MTA”); ’1124 Paper 46 (“’1124 Opp. MTA”); ’1124 Paper 55 (“’1124 Reply MTA”); ’1124 Paper 64 (“’1124 Sur-Reply MTA”).

A. *Proposed Substitute Claims*

Patent Owner proposes to substitute claims 32–62 for claims 1–31. Substitute claims 32–62 represent a one-for-one substitution for original claims 1–31 in compliance with 37 C.F.R § 42.121(a)(3).

Proposed substitute claim 32 is reproduced below, with added text underlined and deleted text stricken through. MTA, App’x A.

32. A voltage regulator, comprising:

regulator circuitry generating a regulated voltage from a first power supply and a second power supply;

wherein the regulated voltage is a DC voltage;

voltage spike protection circuitry for voltage-spike-protecting the regulator circuitry, comprising a dissipative element and a charge-storage circuit;

wherein the voltage spike protection circuitry is on the same CMOS integrated circuit as switching circuitry of the regulator circuitry;

wherein a value of resistance of the dissipative element is based on a characteristic impedance of a lumped-element

Case IPR2017-00707
Case IPR2017-00708
Case IPR2017-01124
Patent 8,233,250 B2

approximation of a transmission line,
wherein the transmission line comprises the charge-
storage circuit and a parasitic inductance associated with
the regulator circuitry.

Proposed substitute claims 32, 44, and 60 amend original independent claims 1, 13, and 29 respectively to specify that 1) the regulated voltage be a DC voltage and 2) the voltage spike protection circuitry be on the same CMOS integrated circuit as the switching circuitry of the regulator circuitry. MTA 2. Proposed substitute claims 32, 44, 57, 59, and 62 similarly amend original independent claims 1, 13, 26, 28, and 31 respectively. '708 MTA 2. Proposed substitute claims 32, 44, 58, and 61, similarly amend, by inserting these same limitations, original independent claims 1, 13, 27, and 30 respectively.²³ '1124 MTA 2. Proposed substitute claim 58 further adds a requirement that “the intermediate node between the series MOS structures is connected to a bias network.” *Id.* Substitute dependent claims 37 and 50 similarly amend dependent original claims 6 and 19 respectively to add the cited requirement. *Id.* at 3.

Proposed substitute claims 33–43 depend from claim 32 and update claim dependencies to correspond to substitute claim numbers. MTA 2; '708 MTA 2; '1124 MTA 2–3. In addition, proposed substitute claims 33, 35, and 37–39 add further limitations, which are discussed in more detail

²³ Patent Owner inadvertently refers to claims 58 and 61 (instead of original claims 27 and 30) as original claims. '1128 MTA 2.

Case IPR2017-00707
Case IPR2017-00708
Case IPR2017-01124
Patent 8,233,250 B2

below. MTA 2; '708 MTA 2; '1124 MTA 2–3. Proposed substitute claims 45–56 depend from claim 44 and update claim dependencies to correspond to substitute claim numbers. MTA 2; '708 MTA 2; '1124 MTA 2–3. In addition, proposed substitute claims 45, 48, and 50–52 add further limitations, which are discussed in more detail below. MTA 2; '708 MTA 2; '1124 MTA 2–3.

B. Requirements of 35 U.S.C. § 316(d) and 37 C.F.R. § 42.121

Pursuant to 35 U.S.C. § 316(d)(3), “[a]n amendment under this subsection may not enlarge the scope of the claims of the patent or introduce new matter.” *See Aqua Prods., Inc. v. Matal*, 872 F.3d 1290, 1340–41 (Fed. Cir. 2017) (“Part III of this opinion sets forth the judgement of this court on what the Board may and may not do with respect [to] the burden of production on remand in this case,” and “[t]here is no disagreement that the patent owner bears a burden of production in accordance 35 U.S.C. § 316(d).”); *see also, e.g., id.* at 1305–06 (explaining that “patent owner must satisfy the Board that the statutory criteria in § 316(d)(1)(a)–(b) and § 316(d)(3) are met and that any reasonable procedural obligations imposed by the Director are satisfied”). Similarly, 37 C.F.R. § 42.121(a)(2)(ii) provides that a motion to amend may be denied where the amendment seeks to enlarge the scope of the claims of the patent or introduces new subject matter. *See* “Guidance on Motions to Amend in view of *Aqua Products*”

Case IPR2017-00707
Case IPR2017-00708
Case IPR2017-01124
Patent 8,233,250 B2

(“Guidance”) (Nov. 21, 2017)

(https://www.uspto.gov/sites/default/files/documents/guidance_on_motions_to_amend_11_2017.pdf) (stating that, in addition to the requirements of 35 U.S.C. § 316(d), a motion to amend must meet the requirements of 37 C.F.R. § 42.121). In addition, with its motion to amend, a patent owner must set forth “support in the original disclosure of the patent for each claim that is added or amended. 37 C.F.R. 42 § 121(b)(1).

Patent Owner argues that all of the proposed substitute claims narrow, and do not broaden, the original claims. MTA 2; ’708 MTA 2–3; ’1124 MTA 2–3. Petitioner, however, argues that Patent Owner’s proposed amended claims impermissibly broaden the scope of the original claims they substitute for. Opp. MTA, 2–7; ’1124 Opp. MTA, 3–6. In addition, Petitioner argues that the proposed amended claims are inconsistent with and/or unsupported by the Specification. Opp. MTA 7–11, 20; ’1124 MTA 7–9.

Because we find, below, that all of the proposed substitute claims are unpatentable over the prior art of record, we do not reach these arguments regarding broadening of original claims and whether the proposed amended claims are supported by the specification.

C. Patentability

Patent Owner does not have the burden of persuasion with respect to the patentability of substitute claims presented in its Motion to Amend. *See*

Case IPR2017-00707
Case IPR2017-00708
Case IPR2017-01124
Patent 8,233,250 B2

Aqua Products, 872 F.3d at 1327; *see also* Guidance. The burden of persuasion to demonstrate the patentability of substitute claims presented in a motion to amend will ordinarily lie with the petitioner. *See Aqua Products*, 872 F.3d at 1325–26; *see also Western Digital Corp. v. Spex Techs., Inc.*, IPR2018-00082, Paper 13 (PTAB April 25, 2018) (designated informative). For the reasons explained below, considering the entirety of the record before us, we determine that Petitioner has shown, by a preponderance of the evidence that the proposed substitute claims are not patentable over the prior art of record. Patent Owner does not address secondary considerations with respect to the proposed substitute claims. *See* MTA; Reply MTA. To the extent the secondary considerations raised in arguing the patentability of the original claims also apply here, we adopt our analysis from Section II.C.5, above, and conclude that evidence as providing minimal, if any, support for nonobviousness and would not have caused the entirety of the evidence, both for and against obviousness, to weigh in favor of nonobviousness.

1. *Proposed Substitute Claims 32, 34, 36, 40–44, 46, 47, 49, 53–57, and 59–62*

Each proposed substitute independent claims 32, 44, 57, and 59–62 amend original claims 1, 13, 26, and 28–31 by adding two additional limitations 1) “wherein the regulated voltage is a DC voltage,” and 2) “wherein the voltage spike protection circuitry is on the same CMOS integrated circuit as switching circuitry of the regulator circuitry.” MTA 4–

Case IPR2017-00707
Case IPR2017-00708
Case IPR2017-01124
Patent 8,233,250 B2

8; '708 MTA 4–8; '1124 MTA 4–7. Proposed substitute claims 34, 36, 40–43, 46, 47, 49, and 53–56 depend from either claim 32 or claim 44, and amend original claims 3, 5, 9–12, 15, 16, 18, and 22–25 respectively. Other than updating the claim dependencies, proposed substitute dependent claims 34, 36, 40–43, 46, 47, 49, and 53–56 are identical to original corresponding claims 3, 5, 9–12, 15, 16, 18, and 22–25. MTA 4–8; '708 MTA 4–8; '1124 MTA 4–7. Above, in Sections II.C.5, II. D.2, and II.E.2, we determine original claims 1, 3, 5, 9–13, 15, 16, 18, 22–26, and 28–31 would have been obvious over the combination of (1) Shekhawat and McMurray, (2) Shekhawat, McMurray, and Ozawa, or (3) Shekhawat, McMurray, and Wong.

Petitioner argues that even with both additional limitations, given the obviousness of the original claims, the proposed substitute claims would have been obvious over the combination of Shekhawat and McMurray. Opp. MTA 13–18; '708 Opp. MTA 2–9; '1124 Opp. MTA 17–20. According to Petitioner, DC voltage regulators were well-known in the art. MTA 14–17. In fact, Petitioner notes that the '250 patent, itself describes “most battery-operated consumer electronics devices us[ing] DC-DC regulators.” *Id.* at 14 (quoting Ex. 1201, 1:16–19; Ex. 1244 ¶¶ 33–35). Moreover, Petitioner adds that the added limitation requiring the voltage spike protection circuitry to be on the same CMOS integrated circuit as the

Case IPR2017-00707
Case IPR2017-00708
Case IPR2017-01124
Patent 8,233,250 B2

switching circuitry would have been obvious over the combination of Shekhawat and McMurray. *Id.* at 17–20.

Patent Owner disagrees, reiterating its argument, analyzed above in Section II.D.4, that the prior art does not show snubber circuitry on the same chip or integrated circuit as the regulator circuitry. '708 Reply MTA 1–3; '1124 Reply MTA 10–12. As explained in that same Section, we do not agree with Patent Owner's characterization of the prior art, and instead find that Shekhawat discloses both the voltage spike protection and regulator circuitry to be on the same chip. Thus, we agree with Petitioner that this limitation does not alter the patentability analysis of the proposed substitute claims. Patent Owner does not appear to rely on the added limitation "wherein the regulated voltage is a DC voltage," as altering the patentability analysis of the original claims. *See* MTA; '708 MTA, '1124 MTA (none of which address this limitation). We agree that DC voltage regulators were well-known in the art. *See* Pet. 14–17; Ex. 1201, 1:16–19; Ex. 1244 ¶¶ 33–35. And we agree that a person of ordinary skill in the art would have been motivated to implement Shekhawat's voltage spike protection circuitry on the same integrated circuit as the switching circuitry with a reasonable expectation of success. *See* Opp. MTA 18–20.

We have considered the entirety of the evidence submitted by the parties, both for and against obviousness, and determine that Petitioner has shown, by a preponderance of the evidence, that proposed substitute claims

Case IPR2017-00707
Case IPR2017-00708
Case IPR2017-01124
Patent 8,233,250 B2

32, 34, 36, 40–44, 46, 47, 49, 53–57, and 59–62 would have been obvious over the combined teachings of Shekhawat and McMurray.

2. *Proposed Substitute Dependent Claims 33 and 45*

Proposed substitute claims 33 and 45 depend from claims 32 and 44 and amend original claim 2 and claim 14, respectively. In addition to updating the claim dependencies, proposed substitute claims 33 and 45 add to the original claims the limitation “wherein the dissipative element comprises the equivalent series resistance of the charge storage circuitry associated with the charge storage circuit and the resistance associated with metal traces of the integrated circuit.” MTA 4, 6. Above, in Section II.C.5, we determine original claims 2 and 14 would have been obvious over Shekhawat and McMurray. In particular, we found unpersuasive Patent Owner’s argument that the prior art does not disclose a resistance value “based on a characteristic impedance of a lumped-element approximation of a transmission line, wherein the transmission line comprises the charge-storage circuit and a parasitic inductance associated with the regulator circuitry.” Reply MTA 11. As explained in that same Section, the evidence shows that a person of ordinary skill in the art, would have understood McMurray’s equations to be referring to the characteristic impedance of a transmission line and understood McMurray to teach reducing a complex circuit to an equivalent circuit thereby approximating lumped RLC elements of an ideal circuit to a non-ideal equivalent circuit wherein signals are

Case IPR2017-00707
Case IPR2017-00708
Case IPR2017-01124
Patent 8,233,250 B2

transmitted from one source point to a destination point.

We have considered the entirety of the evidence submitted by the parties, both for and against obviousness, and determine that Petitioner has shown, by a preponderance of the evidence, that proposed substitute claims 33 and 45 would have been obvious over the combined teachings of Shekhawat and McMurray.

3. *Proposed Substitute Dependent Claims 35 and 48*

Proposed substitute claims 35 and 48 depend from claims 32 and 44 and amend original claim 4 and claim 17, respectively. In addition to updating the claim dependencies, proposed substitute claims 35 and 48 add to the original claims the limitation “wherein the voltage spike protection circuitry protects against spikes at the first power supply and the second power supply.” MTA 5– 6. Above, in Section II.C.5, we found original claims 4 and 17 would have been obvious over Shekhawat and McMurray.

Petitioner argues that proposed substitute claims 35 and 48 would have been obvious over Shekhawat and McMurray because “[i]mplementing voltage spike protection circuitry to protect against spikes at multiple power supplies was well known” is taught by Shekhawat’s Figure 3. Opp. MTA 21–22 (citing Ex. 1206, Fig. 3; Ex. 1243 ¶¶ 54–55).

In the Motion to Amend, Patent Owner submits that Shekhawat and McMurray fail to disclose the added limitation, stating that “these references disclose high voltage spikes at the *output*, e.g., load.” MTA 11. However, Patent Owner does not address the argument or evidence raised in

Case IPR2017-00707
Case IPR2017-00708
Case IPR2017-01124
Patent 8,233,250 B2

Petitioner's opposition brief. *See* Reply MTA 7–8 (arguing that proposed substitute claims 35 and 48 are supported by the specification, but nowhere addressing Petitioner's obviousness contentions).

We are persuaded by Petitioner's analysis, and find Petitioner has shown that this limitation is taught by the combination of Shekhawat and McMurray. *See* Opp. MTA 21–22; Ex. 1206, Fig. 3; Ex. 1243 ¶¶ 54–55. We have considered the entirety of the evidence submitted by the parties, both for and against obviousness, and determine that Petitioner has shown, by a preponderance of the evidence, that proposed substitute claims 35 and 48 would have been obvious over the combined teachings of Shekhawat and McMurray.

4. *Proposed Substitute Claims 37, 50, and 58*

Proposed substitute claims 37 and 50 depend from claims 32 and 44 and amend original claims 6 and claims 19, respectively. Independent claim 58 amends original claim 27. Each of proposed claims 37, 50, and 58 adds the additional limitation “wherein the intermediate node between the series MOS structures is connected to a bias network.” '1124 MTA 5–7. Above, in Section II.E.2, we found original claims 6, 19, and 27 would have been obvious over Shekhawat, McMurray, and Wong.

Petitioner argues that proposed substitute claims 37, 50, and 58 would have been obvious over the combination of Shekhawat, McMurray, Wong,

Case IPR2017-00707
Case IPR2017-00708
Case IPR2017-01124
Patent 8,233,250 B2

and Diorio.²⁴ '1124 Opp. MTA 9–12. Diorio is titled “High-Voltage CMOS-Compatible Capacitors” and describes a “high-voltage stacked capacitor [that] includes a first capacitor and a second capacitor,” each of which includes “a first semiconductive body” and a “floating electrode,” which “includes an intercapacitor node.” Ex. 1547, (54), (57). “In one embodiment, stacked capacitor **915** includes a common node 925 comprising a floating gate, as described above, and is coupled to the charge injector **905** and to the charge drain **910**.” *Id.* at 10:29–34. Dr. Leeb testifies that charge injector **905** and charge drain **910** teach a bias network. Ex. 1544 ¶ 26.

According to Petitioner, “it would have been obvious to a POSA implementing the series capacitors of Wong in Shekhawat to add a bias network at an intermediate node, as taught by Dioro” because at the relevant time, the technique was routinely “used to assure that capacitors behave in the desired manner (i.e., by properly dividing voltage among the capacitors).” '1124 Opp. MTA 10–11 (citing '1124 Ex. 1544 ¶ 27). Dr. Leeb testifies that a person of ordinary skill would have “understood that by using a bias network, the reliability of the capacitors that were originally connected in series in Wong’s capacitive divider network could be enhanced

²⁴ U.S. Patent No. 6,842,327 B1 (“Diorio”). IPR2017-01124, Ex. 1547.

Case IPR2017-00707
Case IPR2017-00708
Case IPR2017-01124
Patent 8,233,250 B2

and their consistent operation could be assured despite potential variations during fabrication.” ’1124 Ex. 1544 ¶ 29.

Patent Owner argues that Petitioner has not met its burden to show that proposed substitute claims 37, 50, and 58 would have been obvious. ’1124 Reply MTA 8–10. According to Patent Owner, Petitioner relies only on hindsight to argue that the combination is obvious. *Id.* at 9. In addition, Patent Owner argues that Petitioner’s argument based on what a person of ordinary skill in the art would have understood “should be procedurally barred under 35 U.S.C. § 311(b), which limits *inter partes* review to “ground[s] that could be raised under section 102 or 103 and ***only on the basis of prior art consisting of patents or printed publications.***” *Id.*

We agree with Petitioner. First, we do not agree with Patent Owner’s procedural argument. Petitioner may rely on the knowledge possessed by a person of ordinary skill in the art to show the obviousness of the proposed claims. *See e.g., Merck Sharp & Dohme Corp. v. Hospira, Inc.*, 874 F.3d 724, 730-31 (Fed. Cir. 2017) (affirming obviousness where limitation would have been well known to POSA); *Arendi S.A.R.L. v. Apple Inc.*, 832 F.3d 1355, 1362 (Fed. Cir. 2016) (in IPR, “common sense” can “supply a [missing] limitation”); *Perfect Web Techs.* 587 F.3d at 1328.

Second, the disclosure of Diorio itself along with testimony by Dr. Leeb show that Diorio discloses a bias network and the potential benefit of adding such a network. ’1124 Ex. 1548, 3:18–28, 10:29–34, 13:29–33;

Case IPR2017-00707
Case IPR2017-00708
Case IPR2017-01124
Patent 8,233,250 B2

'1124 Ex. 1544 ¶¶ 26–29. Patent Owner does not sufficiently refute such evidence. Moreover, we note Dr. Leeb's unrebutted testimony that a person of ordinary skill in the art would have been motivated to use these teachings of Diorio to modify Shekhawat's disclosed circuitry. Ex. 1544 ¶¶ 26–29. We have considered the entirety of the evidence submitted by the parties, both for and against obviousness, and determine that Petitioner has shown, by a preponderance of the evidence, that proposed substitute claims 37, 50, and 58 would have been obvious over the combined teachings of Shekhawat, McMurray, Wong, and Diorio.

5. *Proposed Substitute Claims 38 and 51*

Proposed substitute claims 38 and 51 depend from claims 32 and 44 and amend original claims 7 and claims 20, respectively. In addition to updating the claim dependencies, proposed substitute claims 38 and 51 add to the original claims the limitation "wherein the switching frequency of the regulator circuitry is greater than or equal to 10 MHz." MTA 5, 7. Above, in Section II.C.5, we found original claims 7 and 20 would have been obvious over Shekhawat and McMurray.

Petitioner argues that proposed substitute claims 38 and 51 would have been obvious over Shekhawat and McMurray because "[i]mplementing a regulator with switching frequency that is greater than or equal to 10MHz was well-known in the art" as acknowledged by the '250 patent, which explains in the Background that switching frequencies in the tens to

Case IPR2017-00707
Case IPR2017-00708
Case IPR2017-01124
Patent 8,233,250 B2

hundreds of MHz can be used. Opp. MTA 22 (citing Ex. 1201, 3:60–61); Ex. 1243 ¶ 59 *see also* Ex. 1239, (57) (patent issued in 1999). According to Petitioner, a person of ordinary skill “would have been further motivated to use Shekhawat with switches that operate at a switching frequency of 10 MHz or more to enable the circuitry to operate on chip with reduced energy storage elements” and that “operating a regulator at high switching frequency has several advantages, such as reducing the size of the output filter and allowing fast dynamic response.” *Id.* at 23–24 (citing Ex. 1243); Ex. 1243 ¶ 60.

Patent Owner makes the same procedural argument that arguments about the knowledge of a person of skill in the art are barred as in Section III.C.4., above. Reply MTA 12. We reject this argument for the same reasons discussed above. In addition, Patent Owner argues that the prior art does not disclose any switching frequencies or regulated voltages and that Petitioner has not shown that any of the “newly cited art” that show the claimed ranges of frequencies “disclose the other limitations of the claims, that they are analogous art to the ’250 patent, or explained why a POSA would have looked to those particular references for guidance on appropriate switching frequencies and regulated voltages” for the relevant circuit type. *Id.*

We disagree that Petitioner’s reliance on Exhibits 1239, 1242, and 1243 was improper. These references constitute corroborating evidence of

Case IPR2017-00707
Case IPR2017-00708
Case IPR2017-01124
Patent 8,233,250 B2

what a person of ordinary skill in the art would have known. *Ariosa Diagnostics*, 805 F.3d at 1365 (“Art can legitimately serve to document the knowledge that skilled artisans would bring to bear in reading the prior art identified as producing obviousness.”). Moreover, we are persuaded by Petitioner’s analysis and find Petitioner has shown that the combination of Shekhawat and McMurray teaches this limitation. See Opp. MTA 22–24; Ex. 1201, 3:60–61; Ex. 1205 ¶¶ 6, 54; Ex. 1239, (57); Ex. 1242, 873; Ex. 1243; Ex. 1244 ¶¶ 56–60. We have considered the entirety of the evidence submitted by the parties, both for and against obviousness, and determine that Petitioner has shown, by a preponderance of the evidence, that proposed substitute claims 38 and 51 would have been obvious over the combined teachings of Shekhawat and McMurray.

6. *Proposed Substitute Claims 39 and 52*

Proposed substitute claims 39 and 52 depend from claims 38 and 51 and amend original claims 8 and claims 21, respectively. In addition to updating the claim dependencies, proposed substitute claims 39 and 52 add to the original claims the limitation “wherein the regulated voltage is 0.56-3.4 volts (DC).” MTA 5, 7. Above, in Section II.C.5, we determined original claims 8 and 21 would have been obvious over Shekhawat and McMurray.

Petitioner argues that proposed substitute claims 39 and 52 would have been obvious over Shekhawat and McMurray because “[i]mplementing a regulator providing a regulated voltage within 0.56-3.4 volts (DC) was

Case IPR2017-00707
Case IPR2017-00708
Case IPR2017-01124
Patent 8,233,250 B2

well known in the art” as acknowledged by the ’250 patent. Opp. MTA 24 (citing Ex. 1201, 1:16–19; Ex. 1244 ¶¶ 61–64). Petitioner also offers evidence, in the form of multiple references, that are sufficient to establish that this voltage range was well-known to one of ordinary skill in the art. *Id.* (citing Ex. 1243, 876; Ex. 1241, 370). According to Petitioner, a person of ordinary skill “would have been motivated to implement Shekhawat’s regulator with the proposed voltage range” and that “Shekhawat expressly refers to [the] use of MOSFETs, which were known to operate within the claimed voltage range.” *Id.* at 25 (citing Ex. 1206, 3:30–34; 5:1–6); Ex. 1243 ¶ 65.

Patent Owner makes the same arguments regarding proposed substitute claims 39 and 52 as it does for proposed substitute claims 38 and 51. Reply MTA 12. We reject these arguments for the reasons given above in Section III.C.5.

We are persuaded by Petitioner’s analysis and find Petitioner has shown that this limitation is taught by the combination of Shekhawat and McMurray. *See* Opp. MTA 24–25; Ex. 1201, 1:16–19; Ex. 1205 ¶¶ 54, 60, 100; Ex. 1241, 370; Ex. 1243, 876; Ex. 1244 ¶¶ 61–65. We have considered the entirety of the evidence submitted by the parties, both for and against obviousness, and determine that Petitioner has shown, by a preponderance of the evidence, that proposed substitute claims 39 and 52 would have been obvious over the combined teachings of Shekhawat and McMurray.

Case IPR2017-00707
Case IPR2017-00708
Case IPR2017-01124
Patent 8,233,250 B2

IV. CONCLUSION

For the foregoing reasons, we determine that Petitioner has shown, by a preponderance of the evidence, that claims 1–31 would have been obvious. In addition, we determine that Petitioner has shown, by a preponderance of the evidence, that proposed substitute claims 32–62 would have been obvious. We, therefore, deny Patent Owner’s Motion to Amend.

V. ORDER

Accordingly, it is

ORDERED that claims 1–31 of the ’250 patent are held *unpatentable*;
FURTHER ORDERED that Patent Owner’s Motion to Amend is
denied;

FURTHER ORDERED that pursuant to 35 U.S.C. § 318(b), upon expiration of the time for appeal of this Decision, or the termination of any such appeal, a certificate shall issue canceling claims 1–31 in U.S. Patent No. 8,233,250 B2; and

FURTHER ORDERED that because this is a final written decision, parties to the proceeding seeking judicial review of the decision must comply with the notice and service requirements of 37 C.F.R. § 90.2.

Case IPR2017-00707
Case IPR2017-00708
Case IPR2017-01124
Patent 8,233,250 B2

For PETITIONER:

Richard Goldenberg
Donald Steinberg
Theodoros Konstantakopoulos
Cosmin Maier
WILMER CUTLER PICKERING HALE & DORR LLP
richard.goldenberg@wilmerhale.com
don.steinberg@wilmerhale.com
theodoros.konstantakopoulos@wilmerhale.com
cosmin.maier@wilmerhale.com

For PATENT OWNER:

James Glass
John McKee
QUINN EMANUEL URQUHART & SULLIVAN, LLP
jimglass@quinnemanuel.com
johnmckee@quinnemanuel.com