

UNITED STATES PATENT AND TRADEMARK OFFICE

BEFORE THE PATENT TRIAL AND APPEAL BOARD

INTEL CORPORATION,

Petitioner,

v.

R2 SEMICONDUCTOR, INC.,

Patent Owner.

Case IPR2017-00705

U.S. Patent No. 8,233,250

PATENT OWNER R2 SEMICONDUCTOR'S NOTICE OF APPEAL

Director of the United States Patent and Trademark Office
c/o Office of the General Counsel
Madison Building East, Room 10B20
600 Dulany Street
Alexandria, VA 22314-5793

Pursuant to 35 U.S.C. §§ 141(c) and 142 and 37 C.F.R. §§ 90.2(a) and 90.3, Patent Owner R2 Semiconductor, Inc. hereby appeals to the United States Court of Appeals for the Federal Circuit from the Patent Trial and Appeal Board's Final Written Decision, entered on July 31, 2018 (Paper 86) (a copy of which is attached), and from all underlying and related findings, orders, decisions, rulings, and opinions that are adverse to R2 Semiconductor.

For the limited purpose of providing the Director with the information requested in 37 C.F.R. § 90.2(a)(3)(ii), R2 Semiconductor further indicates that the issues on appeal may include, but are not limited to, (1) whether the Board erred in construing the challenged claims of U.S. Patent No. 8,233,250, (2) whether the Board erred in determining the prior art rendered the challenged claims obvious, and (3) whether the Board erred in determining the same prior art rendered R2 Semiconductor's proposed substitute claims obvious.

R2 Semiconductor further reserves the right to challenge any finding or determination supporting or relating to the issues above, and to challenge other issues decided adversely to R2 Semiconductor.

Pursuant to 37 C.F.R. § 90.2(a), R2 Semiconductor is (1) filing a copy of this Notice of Appeal with the Director, (2) electronically filing a copy of this Notice with the Federal Circuit, along with the requisite filing fee, and (3) filing this Notice with the Board.

DATED: October 2, 2018

Respectfully submitted,

QUINN EMANUEL URQUHART &
SULLIVAN, LLP

By /s/ James M. Glass
James M. Glass (Reg. No. 46,729)

QUINN EMANUEL URQUHART &
SULLIVAN, LLP
51 Madison Avenue, 22nd Floor
New York, NY 10010
jimglass@quinnemanuel.com

*Attorney for Patent Owner - R2
Semiconductor, Inc.*

CERTIFICATE OF SERVICE

Pursuant to 37 C.F.R. § 90.2(a)(1), on October 2, 2018 the foregoing Notice of Appeal was filed electronically with the Board in accordance with 37 C.F.R. § 42.6(b)(1), and mailed to the Director via Priority Mail Express in accordance with 37 C.F.R. §§ 1.10 and 104.2 at the following address:

Director of the U.S. Patent and Trademark Office
c/o Office of the General Counsel
P.O. Box 1450
Alexandria, VA 22313-1450

Pursuant to 37 C.F.R. § 90.2(a)(2); Fed. R. App. P. 15; and Fed. Cir. R. 15, 25, and 52, on October 2, 2018 the foregoing Notice of Appeal was electronically filed with the Court of Appeals for the Federal Circuit via CM/ECF with requisite fees paid via pay.gov. Pursuant to Fed. Cir. R. 15(a)(1), one copy of this Notice of Appeal is being filed by hand with the Clerk's Office of the Federal Circuit on October 2, 2018.

Pursuant to 37 C.F.R. § 42.6(e) and the parties' agreement to accept electronic service, on October 2, 2018 the foregoing Notice of Appeal was served via e-mail on the following attorneys for Petitioner:

richard.goldenberg@wilmerhale.com
don.steinberg@wilmerhale.com
joshua.stern@wilmerhale.com
michael.summersgill@wilmerhale.com
theodoros.konstantakopoulos@wilmerhale.com

cosmin.maier@wilmerhale.com
shirley.cantin@wilmerhale.com

DATED: October 2, 2018

Respectfully submitted,

By /s/ James M. Glass
James M. Glass (Reg. No. 46,729)

QUINN EMANUEL URQUHART &
SULLIVAN, LLP
51 Madison Avenue, 22nd Floor
New York, NY 10010
jimglass@quinnemanuel.com

*Attorney for Patent Owner - R2
Semiconductor, Inc.*

UNITED STATES PATENT AND TRADEMARK OFFICE

BEFORE THE PATENT TRIAL AND APPEAL BOARD

INTEL CORPORATION,
Petitioner,

v.

R2 SEMICONDUCTOR, INC.,
Patent Owner.

Case IPR2017-00705

Case IPR2017-00706

Case IPR2017-01123

Patent 8,233,250 B2

Before JAMESON LEE, JEAN R. HOMERE, and JENNIFER S. BISK,
Administrative Patent Judges.

BISK, *Administrative Patent Judge.*

FINAL WRITTEN DECISION
Inter Partes Review
35 U.S.C. § 318(a) and 37 C.F.R. § 42.73

Case IPR2017-00705
Case IPR2017-00706
Case IPR2017-01123
Patent 8,233,250 B2

I. INTRODUCTION

Intel Corporation (“Petitioner”) filed three petitions requesting *inter partes* review of U.S. Patent No. 8,233,250 B2 (Ex. 1001, “the ’250 patent”). IPR2017-00705, Paper 4 (“Pet.”); IPR2017-00706, Paper 4 (“’706 Pet.”); IPR2017-01123, Paper 4 (“’1123 Pet.”). In each case we instituted a trial on all challenged claims resulting in review of all claims, 1–31, of the ’250 patent.¹ IPR2017-00705, Paper 10 (“Inst. Dec.”); IPR2017-00706, Paper 10 (“’706 Inst. Dec.”); IPR2017-01123, Paper 10 (“’1123 Inst. Dec.”).

Patent Owner filed a Patent Owner Response in each case. IPR2017-00705, Paper 35 (“PO Resp.”); IPR2017-00706, Paper 35 (“’706 PO Resp.”); IPR2017-01123, Paper 35 (“’1123 PO Resp.”). Similarly, Petitioner filed a Reply in each case. IPR2017-00705, Paper 62 (“Reply”); IPR2017-00706, Paper 62 (“’706 Reply”); IPR2017-01123, Paper 58 (“’1123 Reply”).²

¹ Claims 1–4, 7–9, 13–17, 20–22, and 29 were reviewed in IPR2017-00705, claims 10–12, 23–26, 28, and 31 were reviewed in IPR2017-00706, and claims 5, 6, 18, 19, 27, and 30 were reviewed in IPR2017-01123.

² Both parties also filed in each case a Motion to Exclude Evidence, each of which was fully briefed. IPR2017-00705, Papers 70, 71, 73, 74, 77, 78; IPR2017-00706, Papers 71, 72, 74, 75, 78, 79; IPR2017-01123, Papers 71, 72, 74, 75, 78, 79. Subsequently, the parties withdrew each of these motions. IPR2017-00705, Paper 83; IPR2017-00706, Paper 84; IPR2017-01123, Paper 84.

Case IPR2017-00705
Case IPR2017-00706
Case IPR2017-01123
Patent 8,233,250 B2

In each case, Patent Owner filed a Contingent Motion to Amend, each of which was fully briefed.³ IPR2017-00705, Papers 30, 49, 58, 69; IPR2017-00706, Papers 66, 49, 58, 70; IPR2017-01123, Papers 30, 49, 58, 69.

A transcript of the consolidated oral hearing held on February 8, 2018, has been entered into the record as Paper 84⁴ (“Tr.”).

Because of the substantial overlap in substance, we exercise our discretion and consolidate pursuant to 35 U.S.C. § 315(d), for purposes of this Final Written Decision only, the three proceedings.⁵ For the reasons that follow, Petitioner has demonstrated by a preponderance of the evidence that claims 1–31 of the ’250 patent are unpatentable.

A. Related Matters

The parties indicate that the ’250 patent is involved in *R2 Semiconductor, Inc. v. Intel Corp. et al.*, Civil Action No. 2:16-cv-01011

³ Upon authorization, Patent Owner filed a corrected motion to amend in IPR2017-00706 and Petitioner filed a surreply in all three cases.

⁴ For purposes of this Decision, unless otherwise indicated, a citation to “Paper XX” or “Ex. XXXX” will refer to documents filed in IPR2017-00705. Similarly, “’706 Paper XX” or “’706 Ex. XXXX” will refer to documents filed in IPR2017-00706 and “’1123 Paper XX” or “’1123 Ex. XXXX” will refer to documents filed in IPR2017-01123. Moreover, for efficiency and clarity, unless there is a relevant difference between the cases, we will cite only to documents in IPR2017-00705.

⁵ The parties are authorized to file a consolidated request for rehearing in the three cases.

Case IPR2017-00705
Case IPR2017-00706
Case IPR2017-01123
Patent 8,233,250 B2

(E.D. Tex.) and *Certain Integrated Circuits with Voltage Regulators and Products Containing Same*, Investigation No. 337-TA-1024 (USITC). Pet. 3; Paper 7, 1–2. Petitioner has also challenged the '250 patent in 3 additional petitions (IPR2017-00707, -00708, and -01124). Pet. 3; Paper 7, 1–2.

B. The '250 Patent

The '250 patent relates to voltage regulators, which are “universally used to convert the battery voltage to the desired fixed value to be supplied to the integrated circuit, and to ensure that value remains constant as the battery ages and the current used by the integrated circuit changes.” Ex. 1001, 1:11–24. The '250 patent describes two types of voltage regulators – linear or switched—“switched regulator[s],” in particular,

convert[] a DC input voltage to a time-varying voltage or current, and then make[] use of rectifying or switching elements and passive components such as inductors and capacitors, in conjunction with a control circuit, to re-convert this time-varying signal to a DC voltage at a fixed value differing from the input voltage.

Id. at 1:25–36. According to the '250 patent, “switched mode converters are used for many electronic applications, particularly those where energy efficiency and/or battery life are of critical importance.” *Id.* at 1:57–61. A conventional switched voltage regulator, as described in the '250 patent, is shown in Figure 2 below:

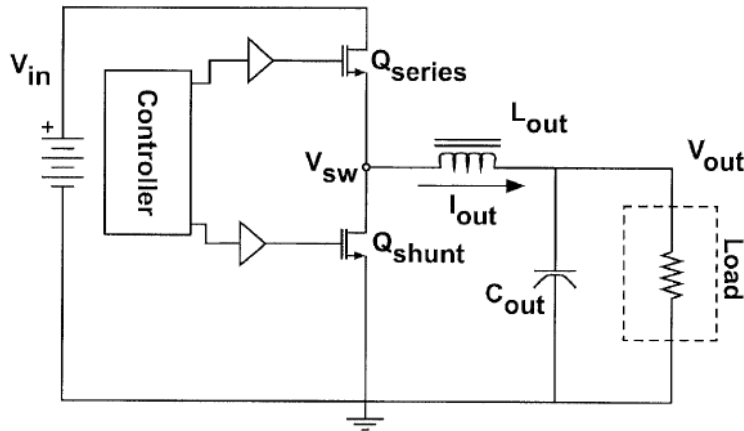

Figure 2 depicts a conventional switched mode regulator having transistor Q_{series} and transistor Q_{shunt} connected at common switching node V_{sw} .

As shown in Figure 2 above, the '250 patent explains that the transistors are alternately turned on and off such that current I_{out} flows from source terminal V_{in} , through operating transistor Q_{series}/Q_{shunt} , and through inductor L_{out} to charge up capacitor C_{out} . *Id.* at 2:2–36.⁶ According to the '250 patent, the intermittent switching of the transistors causes rapid switching in the capacitive load and “voltage spikes will occur in any

⁶ The '250 patent explains that “[w]hen the series switch 301 is rapidly turned off, this parasitic inductor tries to maintain the same output current, causing the voltage V_{hi} to increase rapidly in the absence of any preventive measures . . . [T]he parasitic inductance may interact with parasitic capacitances to form a high frequency resonant circuit, which will create a persistent ringing condition as a result of the initial rapid voltage transition.” Ex. 1001, 16:5–13.

Case IPR2017-00705
Case IPR2017-00706
Case IPR2017-01123
Patent 8,233,250 B2

converter that has fast switching transitions” caused by physical inductances present in any realistic packaged device, including the parasitic inductance of the various components of the circuit. *Id.* at 15:42–65, 16:31–37. In addition, according to the Specification, “most switched mode regulators require large valued (and physically large and thick) external inductors and capacitors to operate.” *Id.* at 1:62–64.

The ’250 patent describes “a need for a DC-DC converter that is simultaneously compact (including optimally fabrication of all active and passive components on a single semiconductor die), low in cost, and highly efficient even at small ratios of output to supply voltage and low output current.” *Id.* at 6:66–7:3. In addition, according to the ’250 patent, “[i]t is desirable to provide spike protection circuitry for the . . . elements of any DC-DC converter employing fast switching transitions.” *Id.* at 16:43–46.

To this end, the ’250 patent describes coupling spike protection circuitry to the regulator circuitry (e.g. DC to DC converter) such that the spike protection circuit protects “switching elements of a converter from transient voltages to allow fast low-loss switching operations without degradation of reliability.” *Id.* at 6:66–67, 7:4–7. The voltage regulator with the protection circuit, as described in the ’250 patent, is shown in Figure 19 below:

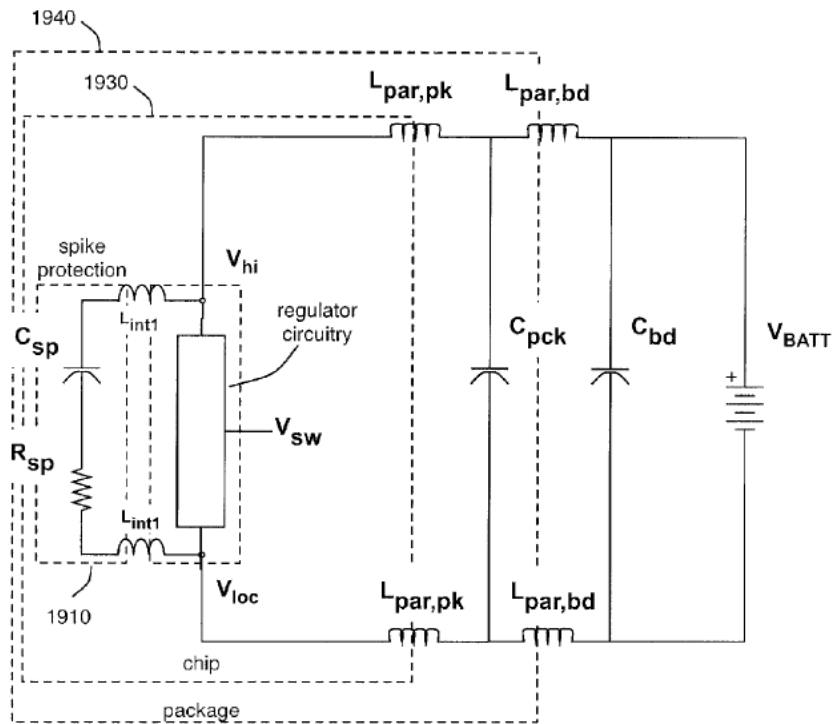

FIGURE 19

Figure 19 shows a voltage regulator including a spike protection circuitry.

As depicted in Figure 19, the '250 patent describes a regulator/switching circuitry wired to generate a regulated voltage from power supply V_{hi} to power supply V_{loc} , both connected to common node V_{sw} . *Id.* at 7:11–13. In addition, spike protection circuitry 1910 including resistor R_{sp} and capacitor C_{sp} is coupled to the regulator circuitry as a way to absorb voltage spikes and ringing caused by parasitic inductances L_{int} , $L_{par,pk}$ and

Case IPR2017-00705
Case IPR2017-00706
Case IPR2017-01123
Patent 8,233,250 B2

$L_{\text{par, bd}}$. *Id.* at 18:10–12.⁷ Thus, according to the Specification, the optimal resistance value typically matches closely the characteristic impedance of a lumped-element approximation to a transmission line containing a charge-storage circuit and a parasitic inductance associated with the regulator circuit. *Id.* at 17:53–67. The '250 patent states that dissipative element R_{sp} can be realized as polysilicon transistors, thin film metallic resistors, or any other convenient resistive element. *Id.* at 18:59–61.

C. Illustrative Claim

Of the challenged claims, claims 1, 13, 26, 27, 28, 29, 30, and 31 are independent. Claim 1 is illustrative and is reproduced below with disputed limitations emphasized:

1. A voltage regulator, comprising:
regulator circuitry generating a regulated voltage from a first power supply and a second power supply;
voltage-spike protection circuitry for voltage-spike-protecting the regulator circuitry, comprising a dissipative element and a charge-storage circuit; wherein
a value of resistance of the dissipative element is based on a characteristic impedance of a lumped-element

⁷ According to the '250 patent, the ringing might also cause a loss in efficiency if the ringing is poorly timed with the opening or closing of one of the switches. It is, therefore, important to incorporate a dissipative element in the spike protection impedance, represented schematically by R_{sp} to minimize undesired ringing in the spike protection circuit. Ex. 1001, 17:24–29.

Case IPR2017-00705
Case IPR2017-00706
Case IPR2017-01123
Patent 8,233,250 B2

approximation of a transmission line, wherein the transmission line comprises the charge-storage circuit and a parasitic inductance associated with generation of the regulator circuitry.

Ex. 1001, 20:31–42.

D. Asserted Grounds of Unpatentability

Petitioner asserts that claims 1–4, 7–17, 20–26, and 29 are unpatentable under § 103(a)⁸ as obvious over Hibino⁹ and McMurray,¹⁰ claims 28 and 31 are obvious over Hibino, and claims 5, 6, 18, 19, 27, and 30 are obvious over Hibino, McMurray, and Wong.¹¹ Pet. 28–72; ’706 Pet. 28–74; ’1123 Pet. 28–72.

⁸ Because the claims at issue have a filing date prior to March 16, 2013, the effective date of the Leahy-Smith America Invents Act, Pub. L. No. 112-29, 125 Stat. 284 (2011) (“AIA”), we apply the pre-AIA version of 35 U.S.C. §§ 102, 103, and 112 in this Decision.

⁹ International Publication No. WO2009/113298 A1 (published Sept. 17, 2009) (“Hibino”). Ex. 1004. In this Decision, all citations are to Exhibit 1005, which contains a certified English translation of Hibino.

¹⁰ William McMurray, “*Optimum Snubbers for Power Semiconductors*,” IEEE Transactions on Industry Applications, Vol. IA-8, No. 5 (Sept./Oct. 1972) (“McMurray”). Ex. 1003.

¹¹ U.S. Patent No. 5,485,292 (issued Jan. 16, 1996) (“Wong”). IPR2017-01123, Ex. 1430.

II. DISCUSSION

A. *Claim Construction*

In an *inter partes* review, a claim in an unexpired patent shall be given its broadest reasonable construction in light of the specification of the patent in which it appears. 37 C.F.R. § 42.100(b). Under the broadest reasonable construction standard, claim terms are given their ordinary and customary meaning, as would be understood by one of ordinary skill in the art in the context of the entire disclosure. *In re Translogic Tech., Inc.*, 504 F.3d 1249, 1257 (Fed. Cir. 2007). Only terms that are in controversy need to be construed, and then only to the extent necessary to resolve the controversy. *Vivid Techs., Inc. v. Am. Sci. & Eng'g, Inc.*, 200 F.3d 795, 803 (Fed. Cir. 1999).

1. “*dissipative element*”

During the pre-institution stage of these proceedings, the parties disagreed regarding the broadest reasonable interpretation of the term “dissipative element.” Pet. 23–27; Prelim. Resp. 18–28. For purposes of the Institution Decision, we agreed with Petitioner and found the term “dissipative element” to be written in means-plus-function format with a function of dissipating energy¹² and a corresponding structure of a resistor.

¹² Both Petitioner and Patent Owner agree that, if construed as requiring means-plus-function treatment, the function of “dissipative element” would be to dissipate energy. Pet. 22, Prelim. Resp. 22.

Case IPR2017-00705
Case IPR2017-00706
Case IPR2017-01123
Patent 8,233,250 B2

Inst. Dec. 9–13. For purposes of analyzing patentability of the challenged claims, Patent Owner does not challenge this construction. PO Resp. 17. We, therefore, adopt the analysis and construction of the term “dissipative element” from the Institution Decision. Inst. Dec. 9–13.

2. “*voltage spike protection circuitry*”

Patent Owner asserts that the terms “voltage spike protection circuitry for voltage-spike protecting the regulator circuitry”¹³ and “voltage-spike-protecting the regulator circuitry with voltage spike protection circuitry”¹⁴ “do not have a plain and ordinary meaning.” PO Resp. 18; Tr. 33:14–39:23. Accordingly, Patent Owner proposes that to properly capture the scope of the claims as reflected in the Specification, these terms should be construed “to require that the voltage-spike protecting circuitry is on the same integrated circuit as the switches they protect.” PO Resp. 18 n.18.

Arguing that Patent Owner’s narrower construction would “improperly limit the claims to certain embodiments,” Petitioner notes that the claims explicitly define “voltage spike protection circuitry” simply as “circuitry that protects the regulator circuitry from voltage spikes.” Reply 3

¹³ As recited by independent claims 1 and 27. Ex. 1001, 20:34–35, 22:31–32. Claim 29, similarly recites “voltage spike protection circuitry . . . for voltage-spike-protecting the regulatory circuitry.” *Id.* at 22:63–65.

¹⁴ As recited by independent claims 13, 26, and 30. Ex. 1001, 21:19–20, 22:17–19, 23:11–12.

Case IPR2017-00705
Case IPR2017-00706
Case IPR2017-01123
Patent 8,233,250 B2

(citing Ex. 1001, claims 1, 13, 26, 28, 29, and 31). Petitioner adds that none of the claims include language requiring that voltage spike protection circuitry to be “located on the same integrated circuit” as the regulator circuitry. *Id.* at 4. Petitioner, therefore, asserts that the broadest reasonable construction of the term “voltage spike protection circuitry” is coextensive with the definition in the claims—“circuitry that protects the regulator circuitry from spikes in voltage.” *Id.*

Notwithstanding Patent Owner’s arguments to the contrary, as discussed below, we agree with Petitioner that the broadest reasonable construction of the voltage spike protection circuitry terms, as used in the ’250 patent, does not limit the location of voltage spike protection circuitry to the same chip or integrated circuit as the regulator circuitry it is designed to protect.

Patent Owner notes that every disclosed embodiment in the ’250 patent shows both the protection circuitry and the regulator circuitry on the same integrated circuit. PO Resp. 19–23. Specifically, Patent Owner points to the embodiments shown in Figures 12, 18, 19, 20, and 22. *Id.* (citing Ex. 1001, Figs. 12, 19, 20, 22, 10:43–46, 16:55–56). Petitioner does not dispute that all the embodiments discussed in the Specification include the voltage spike protection circuitry on the same chip or integrated circuit as the regulator circuitry that it protects. *See* Reply 3–4. Petitioner, however, points out that each of these embodiments is identified as an “example” or

Case IPR2017-00705
Case IPR2017-00706
Case IPR2017-01123
Patent 8,233,250 B2

an “embodiment.” *Id.* (citing Ex. 1001, 10:42; 16:52, 18:15–16, 19:35, 19:47–48). Based on this language, Petitioner argues that “[i]t is improper to read limitations from the embodiments in the specification into the claims.” *Id.* at 4 (citing *Hill-Rom Servs. v. Stryker Corp.*, 755 F.3d 1367, 1371 (Fed. Cir. 2014)). We agree that it would be improper to read this limitation from the Specification into the claims.

Further, Patent Owner asserts that because the Specification employs very fast switching times using small transistors in the integrated circuits, the circuitries must be located on the same integrated circuit. PO Resp. 19–20, 23–24. Specifically, Patent Owner points to the Specification’s acknowledgement that the consumer market demands creation of the “thinnest and smallest devices possible.” *Id.* at 19 (quoting Ex. 1201, 3:38–40). Patent Owner further notes the disclosure that increased switching frequency and the resulting benefit of lower-valued inductors and capacitors allows for “use of planar geometries that can be integrated on printed-circuit boards or fabricated in integrated circuits.” *Id.* at 18–19 (quoting Ex. 1001, 3:58–65). According to Patent Owner, it is this act of achieving very fast switching times using advanced transistors on integrated circuits that causes the problem of voltage spiking that the ’250 patent addresses. *Id.* at 19 (citing Ex. 1001, 5:49–50, 5:60–63, 6:56–65). Petitioner does not dispute that the ’250 patent teaches the benefits of small devices and fast switching

Case IPR2017-00705
Case IPR2017-00706
Case IPR2017-01123
Patent 8,233,250 B2

times, but argues that “these passages say nothing about the *location* of the spike protection circuitry.” Reply 4.

We agree with Patent Owner that the ’250 patent describes the specific problem it is trying to solve in terms that imply single chip implementation. For example, the Specification states that “there exists a need for a DC-DC converter that is simultaneously compact (including optimally fabrication of all active and passive components on a single semiconductor die), low in cost, and highly efficient” that is protected from voltage spikes. Ex. 1001, 6:66–7:7. Dr. Pedram supports this understanding of the ’250 patent, explaining that “[b]y moving the switching transistors on-chip, one can ‘reduce[] the overall size of the voltage regulator’—that is, the size of the inductors and capacitors thereon.” Ex. 2008 ¶ 34 (citing Ex. 1001, 6:66–7:3, 1:62–64). We are, nonetheless, unpersuaded that such description is sufficient to require Patent Owner’s proposed claim construction of the cited term. The claims are written in broad language and do not recite the specific problem to be solved or the need to be satisfied.

Additionally, Patent Owner notes that “in the only section dedicated to voltage spike protection,” the two circuits are placed on the same integrated circuit. PO Resp. 20 (quoting Ex. 1001, 15:51–57 (describing “several physical inductances present in any realistic packaged device, including . . . the parasitic inductance of the traces and/or wirebonds connecting the supply leads or bumps to the contact pads *on the integrated*

Case IPR2017-00705
Case IPR2017-00706
Case IPR2017-01123
Patent 8,233,250 B2

circuit containing the converter”). Similarly, Patent Owner asserts that the ’250 patent “disclaims voltage spike protection circuits that are *not* on the same integrated circuit as the regulatory circuitry,” by stating “[i]t should be noted that inclusion of an off-chip capacitor does not appreciably affect the size of the spikes.” PO Resp. 24 (quoting Ex. 1001, 16:29–30). Petitioner argues that this is not a *disavowal* of non-integrated-circuit implementation, but instead that it “suggests a potential disadvantage.” Reply 4–5 (citing *Epistar Corp. v. Int’l Trade Comm’n*, 566 F.3d 1321, 1335 (Fed. Cir. 2009)). Petitioner adds that “in full context, the passage refers only to a specific ‘example,’ not all voltage spike protection circuits.” *Id.* at 5 (citing Ex. 1001, 16:13–30; Ex. 1045 ¶¶ 20–21). We agree with Petitioner that, although it may suggest a potential disadvantage of a non-integrated-circuit implementation, this language does not rise to disavowal of non-integrated circuits.

We read the Specification, as a whole, as touting the benefit of voltage spike protection circuitry as being more effective in affecting voltage spikes when implemented on the same chip as the regulator circuitry. Ex. 1001, 16:29–30 (“It should be noted that inclusion of an off-chip capacitor does not appreciably affect the size of the spikes.”). Petitioner’s arguments are not inconsistent with this understanding. Reply 4 (“At most, this passage suggests a potential disadvantage associated with non-integration.”). However, the claims are not limited to the most effective

Case IPR2017-00705
Case IPR2017-00706
Case IPR2017-01123
Patent 8,233,250 B2

implementation of the voltage spike protection circuitry. Therefore, this particular benefit does not limit the broadest reasonable interpretation of the claims.

In summary, Patent Owner's argument is that the '250 patent (1) discloses that the problem to be solved with voltage spiking occurs on compact, fast-switching converters, (2) suggests that implementing the voltage spike protection circuitry on a separate chip from the regulator circuitry would be less efficient, and (3) describes multiple embodiments showing only single chip implementation. Despite our agreement with much of this representation of what the '250 patent discloses, we do not agree that such disclosures limit the scope of the claims. Nothing in the '250 patent defines voltage spike protection circuitry to be implemented on the same integrated circuit or the same chip as the regulator circuitry. It is not inconsistent with the Specification for the claim term to read on both implementations. We, therefore, conclude that Petitioner's proposed construction is properly the broadest reasonable construction of the term. *See Smith*, 871 F.3d at 1383. Consistent with the record before us, we construe voltage spike protection circuitry to be "circuitry that protects the regulator circuitry from spikes in voltage."

B. Level of Ordinary Skill in the Art

In determining the level of ordinary skill in the art, various factors may be considered, including the "type of problems encountered in the art;

Case IPR2017-00705
Case IPR2017-00706
Case IPR2017-01123
Patent 8,233,250 B2

prior art solutions to those problems; rapidity with which innovations are made; sophistication of the technology; and educational level of active workers in the field.” *In re GPAC Inc.*, 57 F.3d 1573, 1579 (Fed. Cir. 1995) (internal quotation and citation omitted).

In our Institution Decision, we summarized the parties contentions, notably that Petitioner proposes that the person of ordinary skill “would have a Bachelor of Science degree in Electrical Engineering and two years of graduate work or work experience in power electronics circuit design and chip design, or equivalent experience” and Patent Owner proposes that such person would have “three years of work or research experience in the fields of power electronics or high-speed mixed-signal IC design,” or “a Master’s degree in electrical engineering and two years of work or research experience in the fields of power electronics or high-speed mixed-signal IC design.” Inst. Dec. 13–14 (citing Ex. 1002 ¶ 57; Ex. 2001 ¶ 92). We adopted Patent Owner’s proposed level because we did not “observe a meaningful difference[] between the parties’ assessments,” found either assessment to be “consistent with the level of ordinary skill in the art at the time of the invention as reflected in the prior art,” and found the Decision “supported by either assessment.” *Id.* at 14 (citing *Okajima v. Bourdeau*, 261 F.3d 1350, 1355 (Fed. Cir. 2001)).

Post-institution, neither party further addresses the proper level of ordinary skill in the art. *See* PO Resp., Reply. Thus, for purposes of this

Case IPR2017-00705
Case IPR2017-00706
Case IPR2017-01123
Patent 8,233,250 B2

Decision, we continue to adopt Patent Owner’s proposed level of ordinary skill in the art.

C. Obviousness over Hibino and McMurray

Petitioner asserts that claims 1–4, 7–17, 20–26, and 29 are unpatentable under 35 U.S.C. § 103(a) as obvious over the combined teachings of Hibino and McMurray. Pet. 28–72; ’706 Pet. 28–72. Patent Owner disagrees. PO Resp. 59–84; ’706 PO Resp. 63–90. As discussed below, Petitioner has made a persuasive showing as to this assertion.

1. Overview of Hibino

Hibino describes a power converter system for converting AC or DC power to AC power having a predetermined voltage and frequency, including a “snubber circuit.”¹⁵ Ex. 1005, Abstract. Figure 4 of Hibino is reproduced below.

¹⁵ The function of a snubber circuit is analogous to that of a voltage spike protection circuit. *See* Ex. 1005 ¶ 5.

Case IPR2017-00705
Case IPR2017-00706
Case IPR2017-01123
Patent 8,233,250 B2

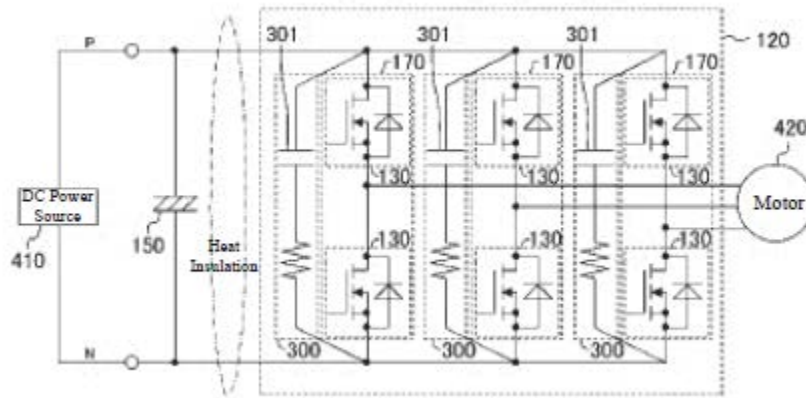

Figure 4 shows a power converter with a snubber circuit.

Figure 4 depicts power converter 400 containing snubber circuit 300 for each switching device 130. *Id.* ¶ 76. Snubber circuit 300 includes capacitor 301 and a resistor (unlabeled) and is used as a protection circuit to reduce any surge voltage generated by an inductance of a wiring when a switching device is turned on or off. *Id.* at 5, 99.

2. *Hibino Qualifies as Prior Art*

Hibino was published September 17, 2009. Ex. 1005, (43). Thus, Petitioner asserts that it is prior art under 35 U.S.C. § 102(a). Pet. 5. Patent Owner, however, argues that Hibino is not prior art to the '250 patent because the inventors of the '250 patent, David Fisher and Lawrence Burns, conceived of the claimed inventions at least as early as September 14, 2009, and thereafter “exercised reasonable diligence to reduce their invention to practice.” PO Resp. 26–59; '706 PO Resp. 27–63; '1123 PO Resp. 28–58. Petitioner argues in response that Patent Owner has failed to demonstrate

Case IPR2017-00705
Case IPR2017-00706
Case IPR2017-01123
Patent 8,233,250 B2

both conception (Reply 5–11) and reduction to practice (*id.* at 11–12). For the reasons discussed below, we agree with Petitioner that Patent Owner has not met its burden to overcome Hibino’s filing date. Specifically, we find that Patent Owner has not sufficiently shown conception of the claimed “value of resistance of the dissipative element is based on a characteristic impedance of a lumped-element approximation of a transmission line” (“the resistance value limitation”)¹⁶.

Patent Owner bears the burden to establish the facts necessary to overcome Hibino’s filing date. *In re Magnum Oil Tools Int’l, Ltd.* 829 F.3d 1364, 1375–76 (Fed. Cir. 2016) (“[I]n the context of establishing conception and reduction to practice for the purposes of establishing a priority date, the burden of production can shift from the patent challenger to the patentee . . . because . . . a patentee bears the burden of establishing that its claimed invention is entitled to an earlier priority date than an asserted prior art reference.”) (internal citations and quotations omitted). To prove conception, Patent Owner is required to show “formation in the mind of the inventor, of a definite and permanent idea of the complete and operative invention, as it is hereafter to be applied in practice.” *Dawson v. Dawson*, 710 F.3d 1347, 1352 (Fed. Cir. 2013) (internal citations and quotations omitted). Moreover, “conception must encompass all limitations of the

¹⁶ Petitioner refers to the resistance value limitation as the “based on” or “matches” limitations. Reply 6.

Case IPR2017-00705
Case IPR2017-00706
Case IPR2017-01123
Patent 8,233,250 B2

claimed invention.” *Brown v. Barbacid*, 276 F.3d 1327, 1336 (Fed. Cir. 2002). “The conception analysis necessarily turns on the inventor’s ability to describe his invention with particularity. Until he can do so, he cannot prove possession of the complete mental picture of the invention.” *Burroughs Wellcome Co. v. Barr Labs., Inc.*, 40 F.3d 1223, 1228 (Fed. Cir. 1994).

Proof of conception must be by “corroborating evidence which shows that the inventor disclosed to others his ‘completed thought expressed in such clear terms as to enable those skilled in the art’ to make the invention.” *Coleman v. Dines*, 754 F.2d 353, 359 (Fed. Cir. 1985) (citing *Field v. Knowles*, 183 F.2d 593, 601 (CCPA 1950)); see also *Mahurkar v. C.R. Bard, Inc.*, 79 F.3d 1572, 1577 (Fed. Cir. 1996) (corroboration requirement “arose out of a concern that inventors testifying in patent infringement cases would be tempted to remember facts favorable to their case by the lure of protecting their patent or defeating another’s patent”). The sufficiency of corroboration is determined according to a “rule of reason.” *Price v. Symsek*, 988 F.2d 1187, 1195 (Fed. Cir. 1993). This, however, does not dispense with the requirement that some independent evidence provide corroboration. *Coleman*, 754 F.2d at 360. The requirement of “independent” corroboration requires evidence other than the inventor’s testimony. *In re NTP, Inc.*, 654 F.3d 1279, 1291–92 (Fed. Cir. 2011).

Case IPR2017-00705
Case IPR2017-00706
Case IPR2017-01123
Patent 8,233,250 B2

To show conception prior to Hibino's priority date, Patent Owner provides testimony from Mr. Fisher that he and Mr. Burns designed an "A101 chip" incorporating the claimed voltage spike protection circuitry. PO Resp. 30–33 (citing Ex. 2015); '706 PO Resp. 31–34 (citing '706 Ex. 2115); '1123 PO Resp. 32–35 (citing '1123 Ex. 2415). According to Patent Owner, the final design of this chip was completed, recorded in schematics, and sent to a manufacturer by September 15, 2009. PO Resp. 30; Ex. 2015 ¶ 70; '706 PO Resp. 32; '706 Ex. 2115 ¶ 70; '1123 PO Resp. 33; '1123 Ex. 2415 ¶ 70. As proof, Patent Owner proffers several A101 chip schematics (Exs. 2016–2020; '706 Exs. 2116–2120; '1123 Exs. 2416–2420). PO Resp. 33–57; '706 PO Resp. 34–60; '1123 PO Resp. 35–56.

Specifically, to show conception of claim 1's resistance value limitation, Patent Owner points to the schematic of Exhibit 2016. *Id.* at 46. According to Patent Owner, this schematic "shows that the parasitic inductance associated with the regulatory circuitry that is located between the supply and regulator circuitry." *Id.* The third page of Exhibit 2016 is reproduced below.

Case IPR2017-00705
Case IPR2017-00706
Case IPR2017-01123
Patent 8,233,250 B2

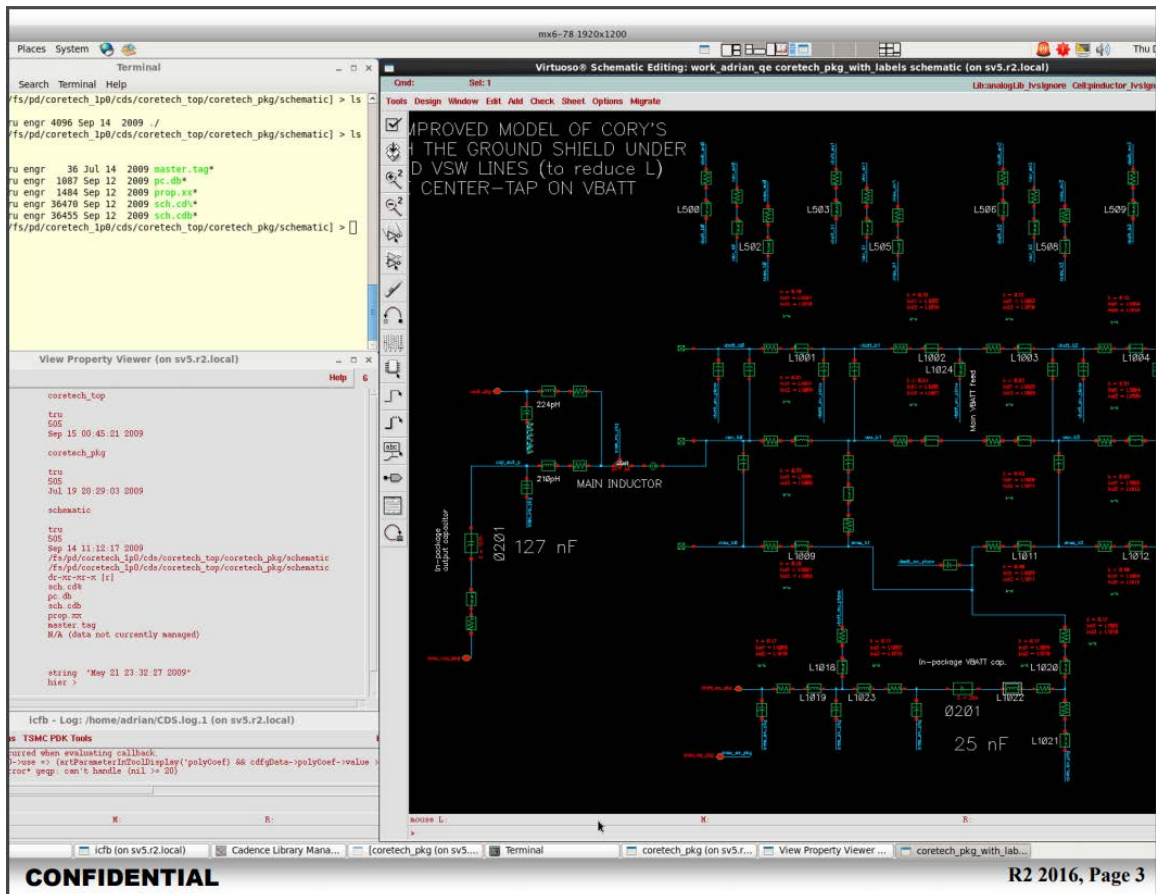

According to Patent Owner, page 3 of Exhibit 2016 shows “a close-up of the inductances” of the “coretech_pkg” created using the system design program “Cadence” at least as early as September 14, 2009. *Id.* at 46–48; Ex. 2015 ¶¶ 51–54. Patent Owner explains that this schematic “shows the parasitic inductances associated with each switching block segment,” including “the elements labelled as L500, L502, L503, L505, L506, L508, L509, L511, L1001, L1002, L1003, L1004, L1024, L1009, L1011, L1012, L1020, L1018, L1019, L1023, L1021, L1022” from each switching block

Case IPR2017-00705
Case IPR2017-00706
Case IPR2017-01123
Patent 8,233,250 B2

segment. Ex. 2015 ¶ 55; PO Resp. 46. Patent Owner also states that the schematic shows inductances associated with “a power supply,” “an integrated circuit package that includes the voltage regulator,” “an integrated circuit that includes the voltage regulator,” and “a power supply of the regulator circuitry.” Ex. 2015 ¶ 55.

Patent Owner, however, does not assert that this schematic, by itself, shows the claimed “characteristic impedance of a lumped-element approximation of a transmission line” on which the resistance value is based. PO Resp. 48. Instead, according to Patent Owner, prior to September 14, 2009, Mr. Fisher and Mr. Burns ran circuit simulations to confirm the characteristic impedance using this model. *Id.*, n.11. The results of these simulations are shown in graphics “created for the purposes of illustration for this IPR proceeding.” *Id.* (citing Ex. 2028); Ex. 2015 ¶ 73. The first page of Exhibit 2028 is reproduced below.

Case IPR2017-00705
Case IPR2017-00706
Case IPR2017-01123
Patent 8,233,250 B2

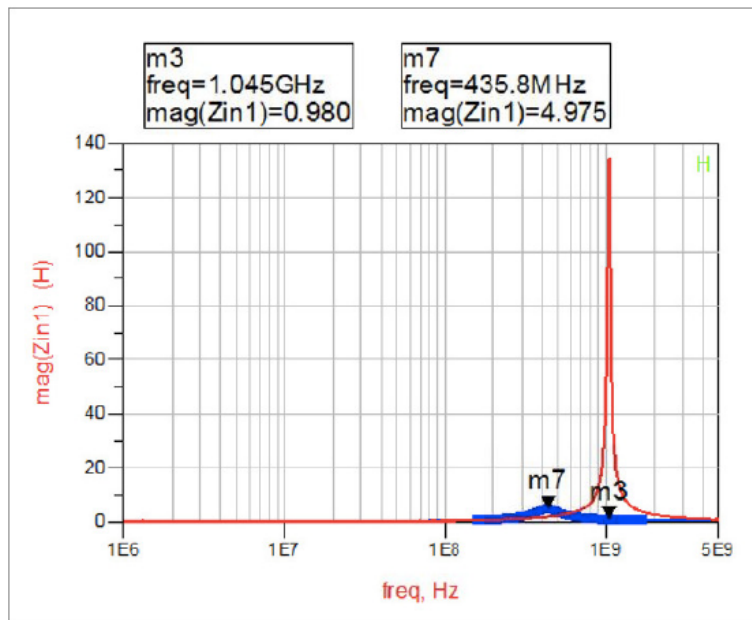

Patent Owner asserts that this graphic shows the results of the pre-September 14, 2009 simulations. Ex. 2015 ¶ 70; Ex. 2008 ¶ 90. To explain the significance of this graphic, however, Patent Owner relies not on testimony from Mr. Fisher, but on testimony from its expert Dr. Pedram. PO Resp. 49–50. According to Dr. Pedram, “[c]alculating the resistance value using the equation for the characteristic impedance for a simplified L and C circuit provides” a resistance of 0.6385 Ω , which “closely matches the actual dissipative element used in the final product of 0.5 Ω ” and “confirms that the value of the resistance in the A101 [s]chematics was based on the characteristic impedance of the lumped-element approximation in the circuit, as of September 14, 2009.” *Id.* at 49–50; Ex. 2008 ¶¶ 91–93.

Case IPR2017-00705
Case IPR2017-00706
Case IPR2017-01123
Patent 8,233,250 B2

Patent Owner also proffers testimony from Mr. Fisher regarding a presentation from September 19, 2008 (Ex. 2027).¹⁷ Ex. 2015 ¶ 40. According to Mr. Fisher, he hand wrote various notes onto the presentation, including one that was shorthand for capturing the inventor’s solution for voltage spike protection, focusing on “the characteristic impedance of a microwave transmission line representation of the voltage regulator and parasitic inductances in the circuit.” *Id.* ¶ 43 (“ μ W [i.e. microwave] R-L-C Dampener ckt. solves high spikes”).

Petitioner argues that Patent Owner has failed to show conception of the resistance value limitation. Reply 6–10. We agree with Petitioner that Mr. Fisher’s testimony purporting to show conception of this limitation is insufficient and Patent Owner has not shown that Dr. Pedram’s supporting testimony makes up for this deficiency.¹⁸

First, we agree that Patent Owner’s handwritten notes on the September 19, 2008 presentation are insufficient evidence that the inventors had conceived of the resistance value limitation prior to the critical date. Nothing in the presentation, including the handwritten note, describes how the resistance value should be calculated. Ex. 2027. And other than stating

¹⁷ Although this testimony and evidence is not referred to in Patent Owner’s briefs, Petitioner discusses them in its Reply. Reply 6–7.

¹⁸ Although Patent Owner bears the burden of overcoming Hibino as prior art, Patent Owner did not request a surreply to address Petitioner’s arguments. Nor did Patent Owner address this issue at the oral hearing.

Case IPR2017-00705
Case IPR2017-00706
Case IPR2017-01123
Patent 8,233,250 B2

that this presentation “shows the solution” of basing the resistance value on the characteristic impedance of a transmission line, Mr. Fisher does not explain how this presentation or the handwritten notes convey this idea. Ex. 2015 ¶¶ 39–44. On the contrary, Dr. Leeb testifies that the notes “do not convey to a POSITA that the inventors in fact conceived of basing a value of resistance on characteristic impedance.” Ex. 1045 ¶ 26. Thus, we are not persuaded that the September 19, 2008 presentation provides any evidence to corroborate Mr. Fisher’s testimony that he and Mr. Burns had conceived of the resistance value limitation.

Second, we are not persuaded that the proffered simulation graphic of the A101 chip schematics shows conception of the resistance value limitation. Mr. Fisher testifies that he and Mr. Burns ran the simulations “to evaluate the characteristic impedance of our design,” and “to show the relationship between voltage spikes and the resistor value,” but he does not explain how these simulations show conception of the resistance value limitation. Ex. 2015 ¶¶ 70–73. In fact, Mr. Fisher testifies that the simulation was run for several different resistance values between 0 and 25 ohms in order to “analyze the effect of the resistance on the spiking of the volume.” Ex. 1049, 91:20–92:18 (citing Ex. 2022); *see also* Ex. 2015 ¶ 71. Thus, neither Mr. Fisher’s testimony, nor the simulation results themselves, indicate that the simulation is evidence that, prior to September 17, 2009, the inventors had conceived of the resistance value limitation. Ex. 2015 ¶¶ 70–

Case IPR2017-00705
Case IPR2017-00706
Case IPR2017-01123
Patent 8,233,250 B2

73; Exs. 2022, 2023, 2028.

Finally, Dr. Pedram's analysis does not make up for these deficiencies. Dr. Pedram, for purposes of this proceeding, calculates a value of "characteristic impedance" of 0.6385Ω using "the equation for the characteristic impedance for a simplified L and C circuit." Ex. 2008 ¶ 92. Dr. Pedram concludes that because this value "closely matches the actual dissipative element used in the final product of 0.5Ω ," it "confirms that the value of the resistance in the A101 Schematics was based on the characteristic impedance of the lumped-element approximation in the circuit, as of September 14, 2009." *Id.* This conclusory analysis is not persuasive. It is unclear on its face, and Dr. Pedram does not explain, why the values .6385 and .5 are close enough to show that the value of the resistance was based on the characteristic impedance of a lumped-element approximation of a transmission line as claimed. Moreover, Dr. Leeb testifies that Dr. Pedram's calculations are incorrect. Ex. 1045 ¶¶ 30–41. For example, Dr. Leeb points out that Dr. Pedram uses a multiplier of .5, without explanation, to determine the resistance value, making his conclusion unreliable. *Id.* ¶ 40. Dr. Leeb also explains that the values of 0.6385 Ohms and 0.5 Ohms, vary by 27.7% and do not "closely match." *Id.* ¶ 41.

As explained above, Patent Owner bears the burden to establish the facts necessary to overcome Hibino's status as prior art to the challenged claims. We have reviewed all the evidence on which Patent Owner relies,

but that evidence does not establish that the subject matter recited in the challenged claims was conceived prior to September 17, 2009. Thus, we conclude that Hibino is prior art to the challenged claims for purposes of these proceedings.

3. Overview of McMurray

McMurray discloses a design procedure for selecting the capacitance and optimum resistance in an RC snubber circuit to limit the peak voltage across a power rectifier or thyristor to absorb energy associated with the recovery current of the device. Ex. 1003, 593–96. An equivalent snubber circuit, as shown in McMurray Figure 1, is reproduced below:

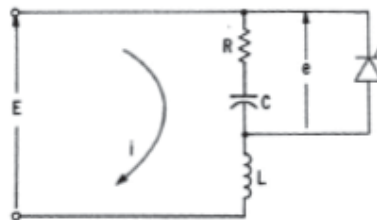

Fig. 1. Equivalent circuit of snubber.

Figure 1 of McMurray shows “[a] voltage E , applied to a series RCL circuit” where “[t]he voltage e across the snubber resistance and capacitance in series appears as recovery voltage on the semiconductor source.” *Id.* at 593. McMurray also discloses equation 58 for calculating the optimum resistor value based on the damping factor and characteristics of the circuit in which the snubber is to be used such as to limit the resulting voltage spike and rate of rise dv/dt . *Id.* at 594. Equation 58 is reproduced below:

Case IPR2017-00705
Case IPR2017-00706
Case IPR2017-01123
Patent 8,233,250 B2

$$R = 2\zeta_0 \sqrt{\frac{L}{C}} = \frac{2\zeta_0 E\chi_0}{I}. \quad (58)$$

Id. at 594–96. Equation 58, above, shows the value “R” necessary to achieve a particular damping factor, such as 1. *Id.* at 596.

4. *McMurray Qualifies as Prior Art*

Patent Owner argues that “Petitioner and Dr. Leeb provide absolutely no support for their bare conclusory statements that McMurray was published in 1972,” thus, not meeting their burden to show that was publicly available before the critical date. PO Resp. 24–25 (citing Pet. 5; Ex. 1002 ¶ 78); ’706 PO Resp. 26–27 (citing ’706 Pet. 5); ’1123 PO Resp. 26–27 (citing ’1123 Pet. 5; ’1123 Ex. 1402 ¶ 78).

We do not agree with Patent Owner that Petitioner has not sufficiently shown that McMurray was publicly available before December 23, 2009 (the filing date of the ’250 patent). McMurray, on its face, indicates that it is an article published in the “September/October 1972” issue of “IEEE Transactions on Industry Applications, Vol. 1A-8, No. 5.” Ex. 1003. Moreover, in the lower left corner of the first page, McMurray notes that it was “approved by the Power Semiconductor Committee of the IEEE Industry Applications Society for presentation at the 1971 IEEE Industry and General Applications Group Annual Meeting, Cleveland, Ohio, October 18–21” and was “released for publication February 23, 1972.” *Id.*

Case IPR2017-00705
Case IPR2017-00706
Case IPR2017-01123
Patent 8,233,250 B2

We credit the publication information on the face of McMurray as evidence of its date of publication and public accessibility. As noted in previous proceedings, “IEEE is a well-known, reputable compiler and publisher of scientific and technical publications.” *Ericsson Inc. v. Intellectual Ventures I LLC*, IPR2014-00527, Paper 41 at 10–11 (PTAB May 18, 2015). Petitioner also points to several other publications that cited McMurray before the critical date. Reply 22 (citing Ex. 1007; Ex. 1011); ’706 Reply 24 (citing ’706 Ex. 1107; ’706 Ex. 1111); ’1123 Reply 25 (citing ’1123 Ex. 1407; ’1123 Ex. 1411). For example, Kassakian, published in 1992 describes McMurray as the “classic” snubber reference. Ex. 1007, 3. Finally, Petitioner provides a declaration of Gerard Grenier, Senior Director of IEEE, which confirms that McMurray was published “on or before September 1972.” Ex. 1052 ¶ 10; ’706 Ex. 1148 ¶ 10; ’1123 Ex. 1459 ¶ 10.

Taken together, the record contains sufficient evidence to show that McMurray was publicly available prior to the ’250 patent’s priority date and, thus, qualifies as prior art. *See Giora George Angres, Ltd. v. Tinny Beauty & Figure, Inc.*, 1997 WL 355479, at *7 (Fed. Cir. June 26, 1997) (unpublished) (finding “no reason to suspect that [a reference published by an established publisher] was not publicly available, including to one skilled in the art” when “no evidence was presented that it was not”) (citing *In re Hall*, 781 F.2d 897, 899 (Fed. Cir. 1986)).

Case IPR2017-00705
Case IPR2017-00706
Case IPR2017-01123
Patent 8,233,250 B2

5. *Obviousness Analysis*

As discussed below, Petitioner accounts for all of the claim limitations required by claims 1–4, 7–17, 20–26, and 29, in the specific arrangement required by each claim, and a reason to combine the teachings of Hibino and McMurray, citing Dr. Leeb’s Declaration for support. Pet. 28–72; Ex. 1002; ’706 Pet. 28–72; ’706 Ex. 1102.

Having considered the entirety of the evidence before us, both for and against obviousness, as explained below, we find that Petitioner has demonstrated, by a preponderance of the evidence, that claims 1–4, 7–17, 20–26, and 29 of the ’250 patent would have been obvious over the combined teachings of Hibino and McMurray.

a. a voltage regulator

We find that Hibino’s “power converter” teaches the claimed “voltage regulator.” See Pet. 30–31 (citing Ex. 1005 ¶¶ 54, 91; Ex. 1002 ¶¶ 92–94) ’706 Pet. 31–32 (citing ’706 Ex. 1102 ¶¶ 92–94). Therefore, based on the evidence before us, we are persuaded that Hibino teaches the “voltage regulator,” as recited by the preamble of claims 1 and 29 and the “method of generating a regulated voltage,” as recited by the preamble of claims 13 and 29. Patent Owner does not disagree with the Petitioner’s contentions regarding this limitation.

Case IPR2017-00705
Case IPR2017-00706
Case IPR2017-01123
Patent 8,233,250 B2

b. regulator circuitry

We find that Hibino’s “‘power source 410’ in Figure 4 provides the power ‘input’ (*i.e.*, supply), and that ‘the snubber circuit (300) is electrically coupled between [the] *two* input terminals of the inverter circuit 120’ (*i.e.*, “p” and “N”).” *See* Pet. at 33–34 (citing Ex. 1005 ¶¶ 57, 63; Ex. 1002 ¶¶ 97–98); ’706 Pet. 32–34 (citing ’706 Ex. 1102 ¶¶ 98–99). Moreover, Hibino’s “upper row” of switching devices 130 “is connected to one of the two input terminals, the first power supply ‘P,’ and the lower row of switching devices 130 . . . is connected to the second power supply ‘N,’” and each switching device “is also connected to a switching node.” *See* Pet. 33–34; ’706 Pet. 32–34. Therefore, based on the evidence before us, we are persuaded that Hibino teaches the “regulator circuitry generating a regulated voltage from a first power supply and a second power supply,” as recited by claim 1, and the similar limitations recited by claims 13, 26, and 29. Patent Owner does not disagree with Petitioner’s contentions regarding this limitation.

c. voltage spike protection circuitry

We find that Hibino’s “snubber circuit” teaches the claimed “voltage spike protection circuitry for voltage-spike-protecting the regulator circuitry, comprising a dissipative element and a charge-storage element.” *See* Pet. 34–35 (citing Ex. 1005 ¶ 5); ’706 Pet. 34–35. Specifically, Hibino discloses that “a snubber circuit is used as a protection circuit so as to reduce the surge

Case IPR2017-00705
Case IPR2017-00706
Case IPR2017-01123
Patent 8,233,250 B2

voltage” to prevent breaking the switching device. Ex. 1005 ¶ 5; Ex. 1002 ¶ 99; ’706 Ex. 1102 ¶ 100. Hibino also discloses that “[i]n many cases, a snubber circuit including a capacitor is used.” Ex. 1005 ¶ 5, Figs. 3B, 4 (showing snubber circuit 300, including capacitor 301 and unlabeled resistor). We find that capacitor 301 and the resistor of snubber of Hibino’s circuit 300 constitute the claimed “charge storage circuit” and “dissipative element,” respectively. *See* Pet. 35–38 (citing Ex. 1005 Figs. 3B, 4; Ex. 1002 ¶¶ 99–109); Ex. 1009, 171; ’706 Pet. 36–38 (citing ’706 Ex. 1102 ¶¶ 100–111).

Patent Owner argues that neither Hibino nor McMurray discloses the “voltage spike protection circuitry” limitations of claims 1, 13, 26, and 29 because neither shows their respective snubber circuitry on the same chip or integrated circuit as the regulator circuitry. PO Resp. 67–74; ’706 PO Resp. 71–78. Above, in Section II.A.2 we agreed with Petitioner’s construction, that the claim, as written, does not require the voltage spike protection to be on the same chip as the regulator circuitry. Nonetheless, we find Petitioner has shown that Hibino discloses the two circuits to be on the same chip. Thus, Hibino discloses this limitation even if we agree with Patent Owner’s more limited construction of the term.

Patent Owner argues that Hibino only discloses snubber circuits that are *separate* from the switching devices they protect because they are connected by bond wires. PO Resp. 71–72 (emphasizing the bond wires

Case IPR2017-00705
Case IPR2017-00706
Case IPR2017-01123
Patent 8,233,250 B2

shown on Figures 7A and B of Hibino); '706 PO Resp. 76–78. According to Patent Owner, “bond wires are not used for interconnections within an integrated circuit.” PO Resp. 71–72 (citing Ex. 2008 ¶ 129); '706 PO Resp. 75–76 (citing '706 Ex. 2108 ¶ 127). Moreover, Patent Owner contends that “[t]here are no ‘integrated circuits’ in Figure 7” of Hibino. PO Resp. 72 (citing Ex. 2008 ¶¶ 130–31); '706 PO Resp. 76 (citing '706 Ex. 2008 ¶ 128). Finally, Patent Owner asserts that “Hibino teaches away from disclosing integrated circuits by disclosing how to implement these separate snubbers and switching devices in Figures 8(a) and 8(b) as *vertical structures*,” which “cannot be used to place the two switching devices on the same integrated circuit due to the vertical stacking of the layers.” PO Resp. 73–74; '706 PO Resp. 77–78.

We do not agree with Patent Owner’s limited reading of Hibino. First, as discussed below, we find that the evidence supports a finding that Hibino explicitly describes the two circuits being on one chip. Moreover, we conclude that Patent Owner’s arguments to the contrary amount to pointing out various examples disclosed by Hibino that do not limit this explicit disclosure. Specifically, we do not find credible Dr. Pedram’s testimony that Dr. Leeb erred in testifying that Figures 7 and 9 of Hibino show integrated circuit implementation in which the snubber and regulator circuitry is on a chip. Ex. 2008 ¶ 126 (stating that Dr. Leeb’s testimony (Ex. 1002 ¶¶ 130, 150) “is wrong”); '706 Ex. 2108 ¶ 125 (referring to '706 Ex.

Case IPR2017-00705
Case IPR2017-00706
Case IPR2017-01123
Patent 8,233,250 B2

1102 ¶¶ 130, 150). This is because Hibino, itself, explicitly describes each of Figures 7 and 9 as “an arrangement of switching devices and snubber circuits *provided on a chip*.” Ex. 1005 ¶ 54 (emphasis added). Instead, we credit Dr. Leeb’s testimony, which is consistent with the language of Hibino that “[i]n Figures 7 and 9, Hibino shows integrated circuit implementations of the converter and snubber circuit in which the circuitry is in a package, *i.e.*, on a chip.” Ex. 1002 ¶ 130 (citing Ex. 1005 ¶ 54); ’706 Ex. 1102 ¶ 130.

Moreover, we agree with Petitioner that “Hibino’s use of bond wires is not inconsistent with its integrated circuit implementation.” *See* Reply 17; ’706 Reply 17. Dr. Pedram concludes that in Hibino the snubber and regulator circuitry are connected by bond wires based on Hibino’s disclosure that “[i]n an actual situation, inductances of a *bonding wire* and the snubber circuit affect the surge voltage.” Ex. 2008 ¶ 127; ’706 Ex. 2008 ¶ 126. Dr. Pedram, however, does not explain, and it is not clear from Hibino, that the bonding wire referred to in that excerpt of Hibino is used for every connection *between* the snubber and regulator circuitry. In fact, both the ’250 patent and Hibino expressly discuss using bond wires for *external*, as opposed to internal, connections. For example, the ’250 patent discusses Figure 22 stating “[i]n the exemplary embodiment, these connections [to supply voltage, output inductor, and local ground connection] are made using a ball grid array package, but bond wires or other contact means may be employed.” Ex. 1001, 19:56–58. Similarly, Hibino discusses an example

Case IPR2017-00705
Case IPR2017-00706
Case IPR2017-01123
Patent 8,233,250 B2

which allows “wire bonding of the snubber circuit directly to the external electrodes.” Ex. 1005 ¶ 110. Thus, we find that the better reading of Hibino is that, as it explicitly describes, in at least some embodiments, the snubber and regulator circuitry may be on the same chip whether or not that embodiment makes use of bond wires for external connections.

We do not agree with Patent Owner that Hibino teaches away from disclosing integrated circuits based on its disclosure that in certain examples SiC MOSFET vertical structures are used, as shown in Figures 8A and 8B. *See* PO Resp. 73–74 (citing Ex. 1005 ¶ 101; Ex. 2008 ¶¶ 131–33); ’706 PO Resp. 77–78 (citing ’706 Ex. 2108 ¶ 132). “A reference may be said to teach away when a person of ordinary skill, upon reading the reference, would be discouraged from following the path set out in the reference, or would be led in a direction divergent from the path that was taken by the applicant.” *In re Gurley*, 27 F.3d 551, 553 (Fed.Cir.1994). Moreover, “[t]he degree of teaching away will of course depend on the particular facts; in general, a reference will teach away if it suggests that the line of development flowing from the reference’s disclosure is unlikely to be productive of the result sought by the applicant.” *Id.* Patent Owner does not explain why a person of ordinary skill, despite Hibino’s disclosure that the circuitry is “on a chip” would read Hibino as requiring the use of these vertical structures in all embodiments. A more reasonable reading of Hibino, given all of its disclosure, is that non-vertical MOSFETs can be

Case IPR2017-00705
Case IPR2017-00706
Case IPR2017-01123
Patent 8,233,250 B2

used.

Finally, we agree with Petitioner that Patent Owner's argument that "McMurray teaches away from integrated circuits because its disclosures are incompatible with them" (PO Resp. 67–71; '706 PO Resp. 71–72) is misplaced because McMurray is not relied upon for bodily incorporation into Hibino. *See* Reply 18–19; '706 Reply 18–19. Instead, Petitioner relies on McMurray for its teachings of finding the optimum value of the snubber circuit resistance so as to reduce voltage spikes in Hibino's voltage regulator. Pet. 33–49; '706 Pet. 34–49.

Therefore, based on the evidence before us, we are persuaded that Hibino teaches the "voltage spike protection circuitry for voltage-spike-protecting the regulator circuitry, comprising a dissipative element and a charge-storage circuit," as recited by claims 1 and 26, and the similar limitations recited by claims 13 and 29.

d. resistance value limitation

With respect to the resistance value limitation, we agree with Petitioner that McMurray teaches a design procedure for selecting the capacitance and optimum resistance for the snubber circuit to limit peak voltage and absorb energy associated with voltage spikes. *See* Pet. 38–43 (citing Ex. 1003, 593, 594, 596; Ex. 1002 ¶¶ 111–18; Ex. 1009, 217); '706 Pet. 38–43 (citing '706 Ex. 1102 ¶¶ 112–119). In particular, we agree with Petitioner that the characteristic impedance of a snubber circuit ("Z₀") equals

Case IPR2017-00705
Case IPR2017-00706
Case IPR2017-01123
Patent 8,233,250 B2

a portion of equation 58—the expression of the square root of the ratio of the parasitic impedance and the capacitance $(L_2/C_s)^{1/2}$.¹⁹ *See* Pet. 39–42 (citing Ex. 1003, 596; Ex. 1002 ¶¶ 114–117; Ex. 1009, 217); ’706 Pet. 39–42 (citing ’706 Ex. 1102 ¶¶ 115–118). Further, we agree that one of ordinary skill using McMurray’s technique to select a resistor of Hibino’s circuit would have used the lumped element approximations to determine the resistance of the snubber circuit. *See* Pet. 43–46 (citing Ex. 1003, 596; Ex. 1002 ¶¶ 119–23); ’706 Pet. 43–46 (citing ’706 Ex. 1102 ¶¶ 120–125).

Patent Owner argues that neither reference by itself nor the combination of the two references discloses “a characteristic impedance of a lumped element approximation of a transmission line” on which the “value of resistance of the dissipative element” could be based. PO Resp. 59–66; ’706 PO Resp. 63–70. First, according to Patent Owner, McMurray “never considers transmission lines.” *Id.* According to Patent Owner, even Petitioner’s expert, Dr. Leeb, admits that there is more than one “theor[y] that explain[s] the transmission of electrical signals through conductors, including for instance ‘a quantum model’” and “McMurray gives no indication that it applies transmission line theory—as opposed to any other method for modeling electrical signals.” *Id.* at 62–63 (citing Ex. 2010 (deposition of Dr. Leeb), 54:22–58:18).

¹⁹ *See* Pet. 42 (citing Ex. 1002 ¶117, Ex. 1011, 72, and explaining that characteristic impedance Z_0 is provided by $(L_2/C_s)^{1/2}$).

Case IPR2017-00705
Case IPR2017-00706
Case IPR2017-01123
Patent 8,233,250 B2

Second, according to Patent Owner “[e]ven if McMurray disclosed transmission lines—it does not—neither Figure 1, any of the equations cited by Dr. Leeb, or any other disclosures in McMurray refer to a ‘characteristic impedance’ that relates to a ‘transmission line.’” *Id.* at 63. According to Patent Owner, McMurray never discusses characteristic impedance and “a person of ordinary skill would not consider McMurray suggesting characteristic impedance.” *Id.* at 61. Patent Owner adds that “even if characteristic impedance can be represented as square root of an inductance divided by a capacitance, McMurray does not disclose the claim limitation.” *Id.* at 64. Patent Owner explains that “characteristic impedance is not an equation,” but, instead, is “an inherent property of a transmission line that defines the impedance that would be seen by a signal if the transmission line were infinitely long,” which can be estimated using many different equations. *Id.* at 64–65. Patent Owner concludes that “[a]ny similarity between the equations in McMurray and those in the specification of the ’250 patent are superficial.” *Id.* at 65.

Going further, Patent Owner argues that McMurray “teaches away from transmission lines.” *Id.* at 65. According to Patent Owner, McMurray relates to power rectifiers (which it refers to as “SCRs”), which are “generally intended for use in circuits requiring hundreds to thousands of volts and currents up to thousands of amps,” such as air conditioner circuits. *Id.* at 65–66. According to Patent Owner, “[i]n a circuit intended to operate

Case IPR2017-00705
Case IPR2017-00706
Case IPR2017-01123
Patent 8,233,250 B2

at 60 Hz a single value of inductance ‘L’ is sufficient for the analysis,” while “transmission lines, which are generally conductors designed to carry electricity or an electrical signal become more relevant at 10 to 100 MHz.” *Id.* at 66 (citing Ex. 2008 ¶ 119; Ex. 2029²⁰, 654–668).

At oral hearing, Patent Owner summed up this argument stating that a person of ordinary skill would not understand the equation in McMurray to show characteristic impedance because the equation “square root of L over C is only characteristic impedance for a uniform lossless line . . . [and] McMurray doesn’t say . . . anything about a uniform lossless line.” Tr. 82:25–83:6.

We do not agree with Patent Owner that a person of ordinary skill’s understanding of McMurray would be so limited. The evidence, as discussed below, shows that a person of ordinary skill in the art, in contrast to Patent Owner’s allegations, would have understood McMurray’s equations to be referring to the characteristic impedance of a transmission line.

We agree with Petitioner that McMurray’s disclosure of $(L/C)^{1/2}$ is the characteristic impedance, Z_0 , of a transmission line based upon which

²⁰ In IPR2017-00706, Patent Owner cites to Ex. 2129. In both cases it is unclear what evidence Patent Owner intends to cite to as support for this statement. Ex. 2029 of IPR2017-00705 and Ex. 2129 of IPR2017-00706 both contain a two-page invoice for attorney services.

Case IPR2017-00705
Case IPR2017-00706
Case IPR2017-01123
Patent 8,233,250 B2

snubber resistance R is calculated. Pet. 42–45 (citing Ex. 1002 ¶ 117). In particular, we agree with Petitioner that the $(L_2/C_s)^{1/2}$ expression of equation 58 equals McMurray’s characteristic impedance (Z_0) and includes approximations of lump values of L and C pertaining to all relevant material inductances and capacitances in the snubber circuit. *Id.* at 44–45. Likewise, we agree with Petitioner that McMurray’s characteristic impedance is that of a transmission line. *Id.* at 45 (citing Ex. 1002 ¶ 123, Ex. 1009, 217). As corroborated by the Ramo textbook, and acknowledged by Patent Owner, we agree with Petitioner that a person of ordinary skill in the art would readily appreciate that that the square root of L/C disclosed in the McMurray equation is that of a transmission line. Reply 15–16 (citing Ex. 1007, 689, Ex. 1009, 45, Ex. 1045 ¶¶ 50–51). As correctly noted by Petitioner, McMurray teaches reducing a complex circuit to an equivalent circuit thereby approximating lumped RLC elements of an ideal circuit to a non-ideal equivalent circuit wherein signals are transmitted from one source point to a destination point (i.e. parasitic inductance in a transmission line). *Id.* at 16.

In addition, Severns (*see* Pet. 8, 13–14, 29–30, 40 n.9), published prior to the filing of the ’250 patent, discusses designing RC-snubber circuits using models that provide good approximations, but tells the reader that “[t]hose interested in a more analytic approach, are referred to the classic paper by McMurray and in this section we will use some of the results of Dr.

Case IPR2017-00705
Case IPR2017-00706
Case IPR2017-01123
Patent 8,233,250 B2

McMurray's paper." Ex. 1011, 12.²¹ Later, when explaining "[f]inding the optimum value for Rs" for a "given choice of Cs and parasitic values," Severns gives "[t]he characteristic impedance (Z_0) of the network" as " $(L_2/C_s)^{1/2}$," and explicitly notes that "[a] detailed exposition can be found in McMurray." *Id.* at 13. Dr. Leeb refers to Severns when testifying that McMurray "is a foundational reference in the art of snubber circuit design." Ex. 1002 ¶ 79; *see also* Ex. 1002 ¶¶ 85 n.7, 115 n.13, 117 (Dr. Leeb testifying that McMurray and Severns teach similar methods for setting R in a snubber circuit). Similarly, Ramo²² (*see* Pet. 10–11, 36, 42, 46), published prior to the filing of the '250 patent, defines the constant Z_0 as "the characteristic impedance of the line" using the equation " $Z_0 = L_v =$

²¹ Exhibit 1011 has two sets of page numbers. For purposes of this Decision, we cite to the page number in the bottom middle of each page of the Exhibit.

²² Patent Owner argues that "Ramo is not asserted as anticipatory art or in combination with McMurray in the Petition, so it is improper for Dr. Leeb to rely" on it for the equation of characteristic impedance. PO Resp. 64. However, we find that Ramo is properly used as corroborating evidence of what a person of ordinary skill in the art would have known. *Ariosa Diagnostics v. Verinata Health, Inc.*, 805 F.3d 1359, 1365 (Fed. Cir. 2015) ("Art can legitimately serve to document the knowledge that skilled artisans would bring to bear in reading the prior art identified as producing obviousness.").

Case IPR2017-00705
Case IPR2017-00706
Case IPR2017-01123
Patent 8,233,250 B2

(L/C)^{1/2}Ω.” Ex. 1009, 45 (emphasis added).²³ Dr. Leeb also addresses Ramo. Ex. 1002 ¶¶ 37, 41, 42, 105, 117, 123.

We give little weight to Dr. Pedram’s testimony to the contrary. First, Dr. Pedram argues that “there are other theories that explain the transmission of electrical signals through conductors,” and explains that Dr. Leeb agrees with this statement. Ex. 2008 ¶¶ 107–108, 110. However, he does not dispute Dr. Leeb’s testimony that the only other theory he could think of, the quantum model, was “probably not commonly the first thing people think of in the theory of transmission lines” and that the “typical theory” that explains how transmission lines transfer or transmit electrical energy and signals is the transmission line theory. Ex. 2010, 55:10–59:18. This testimony, along with the explicit reference to McMurray in Severns and Ramo, shows that a person of ordinary skill in the art would have understood McMurray to be applying transmission line theory—as opposed to any other method for modeling electrical signals—to its circuit diagrams.

Second, Dr. Pedram argues that “[m]any different mathematic equations can be used to estimate the characteristic impedance of a lumped-element approximation of a transmission line” and “not every instance of the equation square root of an inductance over a capacitance means

²³ Exhibit 1009 has two sets of page numbers. For purposes of this Decision, we cite to the page number in the bottom center-right of each page of the Exhibit.

Case IPR2017-00705
Case IPR2017-00706
Case IPR2017-01123
Patent 8,233,250 B2

characteristic equation.” Ex. 2008 ¶ 114. Dr. Pedram then concludes that “[a]ny similarity between the equations in McMurray and those in the specification of the ’250 patent are superficial.” *Id.* ¶ 115. Dr. Pedram, however, does not address Severns’s discussion of that same equation explicitly as “characteristic impedance” and its referral to McMurray for a “detailed exposition” (Ex. 1011, 13) of the equation. The record objective evidence, in the form of literature in the art, directly contradicts Dr. Pedram’s testimony about what a person of ordinary skill in the art would have understood McMurray’s equations to represent.

Finally, we give little weight to Dr. Pedram’s opinion that McMurray teaches away from transmission lines. *See* Ex. 2008 ¶¶ 115–116. Dr. Pedram testifies that because McMurray relates to power rectifiers operating at 60 Hz with a time scale of milliseconds, it is irrelevant to the ’250 patent, which involves circuits operating at much higher frequencies and in a much smaller time scale measured in nanoseconds. *Id.* at 116. This testimony, however, is conclusory, and points to no supporting objective evidence. To the contrary, the objective evidence shows that a person of ordinary skill in the art would have looked to McMurray as demonstrating the general behavior of the components of a snubber circuit independent of the frequencies at which they operate. *See* Ex. 1011 (Severns), 12–13. Moreover, neither Patent Owner nor Dr. Pedram even attempts to show that

Case IPR2017-00705
Case IPR2017-00706
Case IPR2017-01123
Patent 8,233,250 B2

any portion of McMurray criticizes, discredits, or otherwise discourages the use of its disclosure in the context of transmission lines.

In sum, we agree with Petitioner that McMurray's disclosure of $(L/C)^{1/2}$ is the characteristic impedance, Z_0 , of a transmission line based upon which snubber resistance R is calculated. In particular, we agree with Petitioner that the $(L_2/C_s)^{1/2}$ expression of equation 58 equals McMurray's characteristic impedance (Z_0) and includes approximations of lump values of L and C pertaining to all relevant material inductances and capacitances in the snubber circuit. Likewise, we agree with Petitioner that McMurray's characteristic impedance is that of a transmission line. As corroborated by the Ramo textbook, we agree with Petitioner that a person of ordinary skill in the art would readily appreciate that the square root of L/C disclosed in the McMurray equation is that of a transmission line. Further, we agree that McMurray teaches reducing a complex circuit to an equivalent circuit thereby approximating lumped RLC elements of an ideal circuit to a non-ideal equivalent circuit wherein signals are transmitted from one source point to a destination point.

Therefore, based on the evidence before us, we are persuaded that Hibino in combination with McMurray teaches the "a value of resistance of the dissipative element is based on a characteristic impedance of a lumped-element approximation of a transmission line," as recited by claims 1, 13, and 26, and "the value of resistance of the dissipative element matches a

Case IPR2017-00705
Case IPR2017-00706
Case IPR2017-01123
Patent 8,233,250 B2

characteristic impedance of a lumped-element approximation of a transmission line,” as recited by claim 29.

e. “*wherein the transmission line comprises the charge-storage circuit and a parasitic inductance associated with the regulator circuitry*”

We find that Hibino’s capacitor 301 teaches the claimed “charge-storage circuit.” *See* Pet. 46. Moreover, because this capacitor is located in Hibino’s regulator circuit 120, it is “associated with the regulator circuitry.” *See id.* at 46–47 (citing Ex. 1002 ¶ 125). With respect to the claimed “parasitic inductance,” we find that a person of ordinary skill in the art would have understood that all inductances that significantly contribute to voltage spikes to be processed by Hibino’s snubber circuit should be included in the L value of McMurray’s resistance value equation. *See id.* at 47 (citing Ex. 1002 ¶ 126). The evidence supports this finding. For example, Hibino describes that the wires connecting parts of the regulator circuitry have associated inductance based on their length. Ex. 1005 ¶¶ 66–67. That a person of ordinary skill in the art would understand this inductance to be parasitic inductance is confirmed by Zhu, a paper published by IEEE in July, 1999, titled “Characterization of Power Electronics System Interconnect Parasitics Using Time Domain Reflectometry.” Ex. 1022. Zhu states that “[i]nterconnect parasitics are mainly related to device packaging and circuit layout.” *Id.* at 622. These parasitics “exist in all kinds of elements of power convertors, such as . . . wiring cables” and “may significantly affect the converter’s performance.” *Id.* Based on this

Case IPR2017-00705
Case IPR2017-00706
Case IPR2017-01123
Patent 8,233,250 B2

knowledge, Dr. Leeb concludes that “one of ordinary skill using McMurray to select a snubber resistor for Hibino’s regulator would have included Hibino’s parasitic wiring inductances in the L of McMurray’s equivalent circuit.” Ex. 1002 ¶127.

Patent Owner argues that “McMurray does not address parasitic inductance and expressly teaches against it.” PO Resp. 66–67; ’706 PO Resp. 70–71. Patent Owner bases this argument on the fact that McMurray deals with “ideal” circuits, which, because of their ideal nature, do not include parasitic inductance. Pet. 67 (citing Ex. 1003, Fig. 2). According to Patent Owner, the Petition fails to explain how or why McMurray’s disclosure of ideal circuits means leads to a disclosure of parasitic inductance as required by the challenged claims. *Id.* (citing Ex. 2008 ¶¶ 120–121).

As an initial matter, nothing in Patent Owner’s briefing supports their contention of teaching away. Other than the fact that it discusses ideal circuits, Patent Owner does not contend that any portion of McMurray criticizes, discredits, or otherwise discourages the use of parasitic inductance in determining the proper resistance value for Hibino’s snubber circuit. Moreover, nothing in McMurray’s disclosure that “a power converter can usually be reduced to an equivalent circuit” limits its teaching to *only* ideal

Case IPR2017-00705
Case IPR2017-00706
Case IPR2017-01123
Patent 8,233,250 B2

circuits.²⁴ Ex. 1003, 593. To the contrary, the evidence supports a finding that a person of ordinary skill in the art would understand that McMurray applies to actual circuits, which, as previously discussed, such person would have known that non-ideal circuits always include parasitic inductances. *See* Pet. 47–49; Reply 16–17. For example, Dr. Leeb testifies that McMurray’s discussion of reducing circuits to equivalents “applies to actual as well as ‘ideal’ circuits and discloses taking a ‘lumped element approximation’ according to the claims.” Ex. 1045 ¶ 52. And, other than pointing to McMurray’s “idealized” Figure 2, Dr. Pedram does not support his testimony to the contrary. *See* Ex. 2008 ¶¶ 117–118.²⁵ In fact, Mr. Fisher, President and Chief Executive Officer of Patent Owner R2 Semi, agreed that “a lumped element approximation of a transmission line” may be used “to generate an equivalent circuit that’s simplified and could be used for purposes of simulation.” Ex. 1049, 75:19–76:2; Ex. 1045 ¶ 52.

Therefore, based on the evidence before us, the evidence shows that Hibino in combination with McMurray teaches the “charge-storage circuit and a parasitic inductance associated with the regulator circuitry,” as recited

²⁴ Even Patent Owner’s counsel, at oral hearing, doubted that McMurray is not limited to ideal circuits by stating “I think McMurray talks about an ideal transient, I don’t know that it’s saying that the circuit is necessarily ideal.” Tr. 63:10–12.

²⁵ Patent Owner refers to ¶¶ 102–121 of Ex. 2008, but we assume this is a typographical error. PO Resp. 67.

Case IPR2017-00705
Case IPR2017-00706
Case IPR2017-01123
Patent 8,233,250 B2

by claims 1, 26, and 29 and the limitation “wherein the transmission line comprises the charge-storage circuit and a parasitic inductance associated with generation of the regulated voltage,” as recited by claim 13.

f. Reasons to Combine Hibino and McMurray

We agree with Petitioner that a person of ordinary skill in the art would have looked to McMurray as a known reference on snubber circuits and would have combined McMurray’s equation (58) with those of Hibino to achieve Hibino’s stated goal of “reducing a surge voltage generated in the inverter circuit.” *See* Pet. 28–29 (citing Ex. 1002 ¶ 89; Ex. 1003, 593–96; Ex. 1005 ¶ 63; Ex. 1007, 689).

Patent Owner argues that “[t]he Petition has not demonstrated that a POSITA would have been motivated to combine Hibino with McMurray” because they “address different problems using different solutions implemented in different technologies” and “[t]he combination of the two would be incompatible and not yield predictable results.” PO Resp. 75–82; ’706 Pet. 82–87. Patent Owner contends that “Hibino is directed to AC motors in high temperature applications” using a solution “that is specific to motors built using silicon carbide (SiC), or other wide band gap semiconductors . . . not conventional silicon (Si).” *Id.* at 76 (citing Ex. 1005 ¶¶ 3–4, 57). According to Patent Owner, McMurray instead relates to power rectifiers “intended for use in circuits requiring hundreds to thousands of volts and currents up to thousands of amps,” “a ‘latching’ device” as

Case IPR2017-00705
Case IPR2017-00706
Case IPR2017-01123
Patent 8,233,250 B2

opposed to one using transistors, like Hibino. *Id.* (citing Ex. 1003, 593). Patent Owner explains that these two types of devices do not have the “same voltage and current levels.” *Id.* (citing Ex. 2008 ¶¶ 138–140). In addition, Patent Owner argues that Hibino addresses the upper limit of an allowable temperature of SiC switching devices, while McMurray addresses the problem of “reverse recovery.” *Id.* at 77 (citing Ex. 1005 ¶¶ 7–8; Ex. 1003, 593; Ex. 2008 ¶¶ 141–143). Moreover, according to Patent Owner the two references “disclose incompatible solutions to the different problems they address” because Hibino “tries to keep the voltage constant and minimize ringing,” while McMurray “is meant to manage the transition from zero to some final device voltage value ‘E.’” *Id.* at 78–79 (citing Ex. 1005 ¶¶ 59, 72; Ex. 1003, 593; Ex. 2008 ¶ 145). Patent Owner concludes that “[t]he combination of the two would be incompatible and would certainly not yield predictable results.” *Id.* at 79 (citing Ex. 2008 ¶ 146).

The evidence supports a finding that a person of ordinary skill in the art would have been motivated to combine McMurray’s equations for a resistance value with Hibino’s circuit. The evidence shows that a person of ordinary skill in the art would have understood McMurray to be a general reference on snubbers, not specifically related only to power rectifier circuitry. *See* Ex. 1007, 3 (“McMurray’s paper . . . is the classic snubber reference,” including “techniques for designing conventional RLC snubbers.”); Ex. 1011, 12 (referring to McMurray’s paper and using its

Case IPR2017-00705
Case IPR2017-00706
Case IPR2017-01123
Patent 8,233,250 B2

disclosed equation to “demonstrate the general behavior of an RC snubber”). This same evidence shows that although McMurray discusses a particular problem to be solved, its teachings are not restricted to that problem. Instead a person of ordinary skill would understand McMurray’s teachings to be generally relevant to snubbers and the problem of voltage spike protection. *See Cross Med. Products v. Medtronic Sofamor Danek Inc.*, 424 F.3d 1293, 1323 (Fed. Cir. 2005) (“One of ordinary skill in the art need not see the identical problem addressed in a prior art reference to be motivated to apply its teachings.”); *EWP Corp. v. Reliance Universal Inc.*, 755 F.2d 898, 907 (Fed. Cir. 1985) (“A prior art reference must be considered for everything it *teaches* by way of technology and is not limited to the particular *invention* it is describing and attempting to protect.”).

Moreover, we agree with Petitioner that Patent Owner’s argument regarding incompatible solutions and unpredictable results assumes a requirement of bodily incorporation of McMurray’s power rectifiers into Hibino circuitry. *See* Reply 19–20. This, however, is not consistent with Petitioner’s assertions. Instead, the Petition’s proposed modification is aimed at extending, to Hibino’s circuitry, McMurray’s technique for calculating an optimum value of the snubber circuit resistance as a way to reduce voltage spikes in Hibino’s voltage regulator. *See* Pet. 34–46; ’706 Pet. 34–46. As a result, we are persuaded that the combination proposed by Petitioner is proper.

Case IPR2017-00705
Case IPR2017-00706
Case IPR2017-01123
Patent 8,233,250 B2

Finally, Patent Owner argues that Dr. Leeb's testimony regarding motivation to combine is insufficient. We do not agree with Patent Owner's characterization of Dr. Leeb's testimony and, more generally, of the evidence of record. As discussed above, we credit Dr. Leeb's testimony that "[a] person of ordinary skill, reading Hibino, would have known to set the value of the resistor in Hibino's snubber circuit to achieve Hibino's goal of 'reducing a surge voltage generated in the inverter circuit.'" Ex. 1002 ¶ 88. This testimony is supported by Hibino itself. Ex. 1005 ¶ 63 ("The snubber circuit (300) is a circuit for reducing a surge voltage generated in the inverter circuit. . . ."); ¶¶ 5, 9, 63, 67, 76. We also credit Dr. Leeb's testimony that a person of ordinary skill would have looked to McMurray for the well-known method of setting an appropriate resistor value for that circuit. Ex. 1002 ¶ 89. This testimony is supported by McMurray and confirmed by other available publications. Ex. 1003, 593–595; Ex. 1007, 3; Ex. 1011, 12–13. We give little weight to Dr. Pedram's testimony to the contrary that focuses on certain, isolated portions of the references as opposed to their teaching as a whole.

In sum, the evidence, as discussed above, supports a finding that a person of ordinary skill in the art would have had reason to apply McMurray's equation for resistance value to Hibino's circuit.

Case IPR2017-00705
Case IPR2017-00706
Case IPR2017-01123
Patent 8,233,250 B2

g. Objective Indicia of Non-Obviousness

The Supreme Court explained that various factors “may also serve to ‘guard against slipping into use of hindsight,’ and to resist the temptation to read into the prior art the teachings of the invention in issue.” *Graham v. John Deere Co.*, 383 U.S. 1, 36 (1966) (citation omitted). These factors are commonly known as secondary considerations or objective indicia of non-obviousness. Secondary considerations are an important part of the obviousness analysis, evidence of which we must consider. *See Transocean Offshore Deepwater Drilling, Inc. v. Maersk Drilling USA, Inc.*, 699 F.3d 1340, 1349 (Fed. Cir. 2012).

Patent Owner introduces evidence that it contends shows secondary considerations of non-obviousness. PO Resp. 81–84; ’706 PO Resp. 87–91. Specifically, Patent Owner groups its evidence into three categories, long-felt need, teaching away, and industry skepticism. *Id.* We have considered all of Patent Owner’s evidence of secondary considerations. Upon consideration, however, we conclude that in each category of objective evidence submitted by Patent Owner, Patent Owner’s evidence is entitled to minimal weight because Patent Owner has not sufficiently shown a nexus between the evidence and the merits of the challenged claims of the ’250 patent. *Wyers v. Master Lock Co.*, 616 F.3d 1231, 1246 (Fed. Cir. 2010) (“For objective [evidence of secondary considerations] to be accorded

Case IPR2017-00705
Case IPR2017-00706
Case IPR2017-01123
Patent 8,233,250 B2

substantial weight, its proponent must establish a nexus between the evidence and the merits of the claimed invention.”).

In addition, Patent Owner has not provided sufficient supporting or contextual evidence for us to properly evaluate the probative value of Patent Owner’s theories. As explained below, for each category of objective evidence, Patent Owner’s arguments relating to these objective indicia of non-obviousness are conclusory and not fully developed or explained. On balance, we view Patent Owner’s evidence as providing very minimal, if any, support for nonobviousness. These findings and conclusions regarding Patent Owner’s objective indicia of nonobviousness apply to all of the claims and grounds for unpatentability.

Long-Felt Need

“Evidence of a long-felt but unresolved need can weigh in favor of the non-obviousness of an invention because it is reasonable to infer the need would not have persisted had the solution been obvious.” *Apple Inc. v. Samsung Elecs. Co.*, 839 F.3d 1034, 1056 (Fed. Cir. 2016).

Patent Owner asserts that, at the time of the ’250 patent, “there existed a need for an integrated voltage regulator that was low in cost, and highly efficient.” PO Resp. 81. To support this contention, Patent Owner points to discussion in the ’250 patent itself, which explains that current voltage regulators could not meet industry expectations and that prior attempt to solve the problem were not commercially viable because of large voltage

Case IPR2017-00705
Case IPR2017-00706
Case IPR2017-01123
Patent 8,233,250 B2

swings. *Id.* (citing Ex. 1001, 1:39–61, 5:33–6:54). In addition, Patent Owner points to International Patent Application No. WO 2013/048475 filed September 30, 2011, and owned by Petitioner. *Id.* at 82 (citing Ex. 2011). According to Patent Owner, in this application, Petitioner “acknowledged that it was facing the same problems in 2011 that were acknowledged in the ’250 patent.” *Id.* (quoting Ex. 2011, 2). Patent Owner also notes that in granting a claim from a related European Patent Application, “the Examiner noted that the prior art of record did not disclose ‘wherein values of a resistor and capacitor of the resistor capacitor damping network are determined by a parasitic inductance of the input voltage.’” *Id.* at 83 (quoting Ex. 2011, 60).

Patent Owner’s evidence is insufficient to show a long-felt need in several respects. First, Patent Owner “provided no evidence to explain how long this need was felt, or when the problem first arose.” *Perfect Web Techs., Inc. v. InfoUSA, Inc.*, 587 F.3d 1324, 1332 (Fed. Cir. 2009); *see also Iron Grip Barbell Co. v. USA Sports, Inc.*, 392 F.3d 1317, 1325 (Fed. Cir. 2004) (“Absent a showing of long-felt need or the failure of others, the mere passage of time without the claimed invention is not evidence of nonobviousness.”). Second, we are not persuaded that Patent Owner’s evidence, including assertions from its own patent application and an application from Petitioner, which Petitioner subsequently disclaimed (*see* Reply 23 (citing Ex. 1055)), is sufficient to show that the alleged need was

Case IPR2017-00705
Case IPR2017-00706
Case IPR2017-01123
Patent 8,233,250 B2

long-felt and remained unsolved at the time of the invention despite prior attempts by others in the field to provide a solution. *Monarch Knitting Mach. Corp. v. Sulzer Morat GmbH*, 139 F.3d 877, 884 (Fed.Cir.1998) (“The relevant secondary consideration is ‘long-felt but unsolved need,’ not long-felt need in isolation.”); *see also In re Kahn*, 441 F.3d 977, 990 (Fed. Cir. 2006) (“[O]ur precedent requires that the applicant submit actual evidence of long-felt need, as opposed to argument.”). We agree with Petitioner that the mere filing of applications (by Patent Owner or Petitioner) directed towards allegedly similar technology does not constitute evidence of a “long-felt need” absent a showing of nexus between the alleged long-felt need and the claims being challenged. Reply 23. Further, because Patent Owner has not proffered testimony from its expert to identify, specifically, how long the alleged need was felt, any prior unsuccessful attempts by other to provide a solution to the alleged problem, the weight of the evidence does not favor Patent Owner’s position. These application statements are merely assertions not supported by underlying evidence.

Finally, for evidence of long-felt but unsolved need to be probative of nonobviousness, a patentee must demonstrate a nexus between that evidence and the patented features. *Apple Inc. v. Samsung Elecs. Co.*, 816 F.3d 788, (Fed. Cir. 2016), (*other grounds vacated on rehearing en banc* by 839 F.3d 1034 (Fed. Cir. 2016)). Nothing in the claims requires that the invention be “low in cost” or “efficient” and Patent Owner provides no supporting data to

Case IPR2017-00705
Case IPR2017-00706
Case IPR2017-01123
Patent 8,233,250 B2

show that the invention actually reduced cost or efficiency of integrated voltage regulators.

We, therefore, determine that Patent Owner's evidence proposed to show a long-felt, but unsatisfied, need, is entitled to little weight.

Teaching Away

Whether prior art teaches away from the claimed invention has been regarded as an objective indicia of nonobviousness. *See Ecolchem, Inc. v. S. Cal. Edison Co.*, 227 F.3d 1361, 1379 (Fed. Cir. 2000).

Patent Owner asserts that "International Patent Publication WO 2008/011530 . . . was filed on July 19, 2017 and actively teaches away from using a resistor and capacitors for spike protection" because it "expressly criticizes that technique for 'increas[ing] components and size of the controller as well as decreas[ing] its efficiency.'" PO Resp. 83–84 (quoting Ex. 1014²⁶, 5:8–28, 3:49–64). Patent Owner provides no other explanation or evidence of how this disclosure affects our obviousness analysis.

Petitioner argues that the language pointed to by Patent Owner "merely acknowledges consequences of a particular approach," but does not teach away from the claimed invention. Reply 24.

²⁶ Exhibit 1014 contains an office action for U.S. Application No. 12/646,451, and appears unrelated to WO 2008/011,530. PO Resp. 83–84; Ex. 1014. The record, therefore, does not show that WO 2008/011530 states what Patent Owner represents that it describes.

Case IPR2017-00705
Case IPR2017-00706
Case IPR2017-01123
Patent 8,233,250 B2

As discussed above with respect to an alleged long-felt need, Patent Owner has not made the requisite showing of nexus. Nothing in the claims requires that the invention be “efficient.” Moreover, we agree with Petitioner that the quoted language does not teach away from the claimed invention. Patent Owner does not explain how this language would have suggested to a person of ordinary skill that the claimed invention would be unlikely to work. *In re Gurley*, 27 F.3d 551, 553, (Fed. Cir. 1994) (“[I]n general, a reference will teach away if it suggests that the line of development flowing from the reference’s disclosure is unlikely to be productive of the result sought by the applicant.”).

We, therefore, determine that Patent Owner’s evidence does not show the prior art taught away from the claimed invention.

“Industry Skepticism”

Under the title “Consideration of Non-Obviousness,” Patent Owner includes, in its Response, a short section titled “Industry Skepticism.” PO Resp. 84. Patent Owner asserts that “[w]hen R2 first promoted its commercial products embodying the ’250 patent to other companies in the industry, many in the industry were not expecting it to achieve its performance goals, including Intel Mobile Corporation, International Rectifier, TriQuint Semiconductor and Motorola Mobility.” PO Resp. 84. To support this assertion, Patent Owner proffers an email from an employee of International Rectifier to several employees of Patent Owner stating “[f]or

Case IPR2017-00705
Case IPR2017-00706
Case IPR2017-01123
Patent 8,233,250 B2

our market and applications in DC:DC it is necessary to convert 12V down to .8 V or so with very high efficiency at high frequency” and “[w]e are hopeful but skeptical of claims for 10’s of MHz switching in this space; please prepare for an eager audience but one prepared to ask some technical questions to validate basis for performance claims.” *Id.* (citing Ex. 2014, 2). Patent Owner provides no other explanation or evidence of how this email shows general industry skepticism of the challenged claims or connects to the identified industry members.

As discussed above with respect to the other two categories, Patent Owner has not made the requisite showing of nexus for industry skepticism. Nothing in the claims requires “10s of MHz switching” or “very high efficiency.” Additionally, we have not been directed to evidence tending to show that Patent Owner’s product embodying the claimed invention actually achieved “10s of MHz switching” or “very high efficiency.” On this record, if there was industry skepticism, the skepticism may have been directed to non-claimed aspects of the product. In any event, a single email from a single person working in the field, at least in the context of this case, is insufficient to establish meaningful “industry skepticism.”

We, therefore, determine that Patent Owner’s evidence proffered to show industry skepticism is entitled to little weight, and does not support a finding of nonobviousness.

Case IPR2017-00705
Case IPR2017-00706
Case IPR2017-01123
Patent 8,233,250 B2

h. Independent Claims 1, 13, 26, and 29

As discussed above, we are persuaded that Petitioner has shown that each of the limitations recited by independent claims 1 and 13 is disclosed by the combined teachings of Hibino and McMurray. Petitioner has shown that the subject matter of claims 1 and 13 would have been obvious over the combined teachings of Hibino and McMurray. *See* Pet. 28–49, 59, 60, 62–70; '706 Pet. 66–72.

Independent claims 1, 13, 26, and 29, all recite substantially similar subject matter. Specifically, claims 1 and 13 have substantially similar limitations, but differ only in that claim 1 is written in device form, “a voltage regulator” and claim 13 is written in method form, “a method of generating a regulated voltage.” Ex. 1001, 20:31–42, 21:15–28. The differences between these two claims do not affect our patentability analysis. And, for the reasons discussed above, in Sections II.C.5.a–II.C.5.g, we conclude that a preponderance of the evidence shows these claims would have been obvious over the combined teachings of Hibino and McMurray.

Claims 26 and 29 are also substantively similar to each other with claim 26 written in method form, “a method of generating a regulated voltage,” and claim 29 written in device form, “a voltage regulator.” Ex. 1001, 22:3–27, and 22:53–23:6.

Claim 26 differs from claims 1 and 13 in that it more specifically recites the functioning of the regulator circuitry. *Id.* For example, claim 26

Case IPR2017-00705
Case IPR2017-00706
Case IPR2017-01123
Patent 8,233,250 B2

recites the regulator circuitry

generating the regulated voltage through controlled closing and opening of a series switch element and shunt switch element, the series switch element being connected between a first voltage supply and a common node, and the shunt switch being connected between the common node and a second supply voltage

Id. at 22:5–11. Claim 26 also recites two periods, during the first of which the series switch element is closed, and during the second, the shunt switch element is closed. *Id.* at 22:12–13. Finally, claim 26 recites

wherein the series switch element and the shunt switch element form switching blocks, and each switching block comprises a plurality of switching block segments, and further comprising voltage-spike-protecting the regulator circuitry with voltage spike protection circuitry, wherein the voltage spike protection circuitry comprising a dissipative element and a charge-storage circuit; wherein

Id. at 22:14–22. We find that Hibino discloses regulator circuitry generating the regulated voltage through controlled opening and closing of series and shunt switch elements. *See* '706 Pet. 49–51, 66–71 (citing '706 Ex. 1105 Fig. 4, ¶¶ 25, 60, 62; '706 Ex. 1102 ¶¶ 130–131, 158–160). Moreover, Hibino discloses a series switching element connected at one end to the first voltage supply, the shunt switching element connected to the second voltage supply, and connected to each other at a common node. *Id.* at 67 (citing '706 Ex. 1102 ¶ 161). We also conclude that a person of ordinary skill would have understood that “to generate a regulated voltage using a

Case IPR2017-00705
Case IPR2017-00706
Case IPR2017-01123
Patent 8,233,250 B2

switching regulator, controlled opening and closing would involve sending a control signal to close the series switch element (transistor) for a period of time and then sending a control signal to close the shunt switch element (transistor) for a second period of time” and Hibino discloses that the control system turns the transistors on and off. *Id.* at 68 (citing ’706 1105 ¶ 62; Ex. ’706 1102 ¶ 162). Therefore, based on the evidence before us, we are persuaded that the evidence shows that Hibino teaches the switching elements of the regulator circuitry recited by claim 26. *See also id.* 69–71 (citing ’706 Ex. 1105, Fig. 4; ’706 Ex. 1102 ¶¶ 162–163. Patent Owner does not address these limitations of claim 26.

Claim 29 is similar to claim 26 and specifically recites the regulator circuitry

generating a regulated voltage from a first power supply and a second power supply, the regulator circuitry comprising a series switch element and a shunt switch element connected between the first power supply and the second power supply, and a switching controller operative to generate a switching voltage through closing and opening of a series switch and a shunt switch as controlled by a series switch control signal and a shunt switch control signal

Id. at 22:54–62. For reasons similar to those discussed, above, regarding claim 26, we find that Hibino discloses this limitation. *See* Pet. 62–66, 70–71 (citing Ex. 1005, Fig. 4, ¶¶ 57, 60, 62; Ex. 1002 ¶¶ 155–159, 171). Patent Owner does not address these limitations of claim 29.

Case IPR2017-00705
Case IPR2017-00706
Case IPR2017-01123
Patent 8,233,250 B2

In addition, as discussed above, in Section II.C.5.f, Petitioner has shown that a person of ordinary skill in the art would have been motivated to combine the teachings of McMurray's equation for the resistance value with the circuitry taught by Hibino. Finally, Patent Owner's evidence of secondary considerations does not impact these findings for the reasons discussed in Section II.C.5.f. Therefore, we determine that Petitioner has shown, by a preponderance of the evidence, that independent claims 1, 13, 26, and 29 of the '250 patent would have been obvious over the combined teachings of Hibino and McMurray.

i. Dependent Claims 2–4, 7–12, 14–17, and 20–25

We have considered Petitioner's argument and supporting evidence, including Dr. Leeb's testimony, regarding dependent claims 2–4, 7–12, 14–17, and 20–25 of the '250 patent. Pet. 49–62; Ex. 1002 ¶¶ 129–144, 150–153, 169–172; '706 Pet. 51–66; '706 Ex. 1102 ¶¶ 130–140, 146–157. We find that Petitioner has shown that these limitations are taught by Hibino and McMurray and has provided sufficiently “articulated reasoning,” with “rational underpinning” and evidentiary support, to combine the teachings of these references to predictably yield the recited systems and methods. *See KSR Int'l Co. v. Teleflex Inc.*, 550 U.S. 398, 418 (2007) (quoting *Kahn*, 441 F.3d at 988). Patent Owner does not explicitly address the additional limitations of the dependent claims.

Case IPR2017-00705
Case IPR2017-00706
Case IPR2017-01123
Patent 8,233,250 B2

Specifically, dependent claims 2 and 14 add “wherein the parasitic inductance comprises an inductance associated with at least an integrated circuit package that includes the voltage regulator, and an integrated circuit that includes the voltage regulator.” Ex. 1001, 20:43–47, 21:32–34. In addition, dependent claims 4 and 17 add “wherein the dissipative element damps ringing of a power supply to the regulator circuitry.” Ex. 1001, 20:51–53, 21:38–41. Claim 16’s added limitation is substantively similar to those in claims 4 and 17—“wherein a value of resistance of the dissipative element is selected to critically damp ringing of a power supply to circuitry that generates the regulated voltage.” Ex. 1001, 21:35–38. For the reasons discussed with regard to the term “voltage spike protection circuitry” (Section II.C.5.a), we find Petitioner has shown these limitations are taught by the combined teachings of Hibino and McMurray. *See* Pet. 49–54, 55, 60–62; Ex. 1002 ¶¶ 129–134, 137, 150, 152, 153.

Dependent claims 3 and 15 add “wherein the parasitic inductance comprises an inductance associated with a power supply of the regulator circuitry.” Ex. 1001, 20:48–50, 21:32–34. We are persuaded by Petitioner’s analysis and find that Petitioner has shown this limitation is disclosed by the combined teachings of Hibino and McMurray. *See* Pet. 54–55, 61; Ex. 1002 ¶¶ 135–136, 151.

Case IPR2017-00705
Case IPR2017-00706
Case IPR2017-01123
Patent 8,233,250 B2

Dependent claims 7 and 20 add “further comprising at least one switching element.”²⁷ Ex. 1001, 20:63–64, 21:50–52. We are persuaded by Petitioner’s analysis and find Petitioner has shown that this limitation would have been obvious over the combined teachings of Hibino and McMurray. *See* Pet. 55–56, 70–71; Ex. 1002 ¶¶ 138–139, 169–170.

Dependent claims 8 and 21 depend from claims 7 and 20 respectively and add “wherein the dissipative element suppresses ringing of the regulated voltage during a switching period of the at least one switching element.”²⁸ Ex. 1001, 20:65–67, 21:53–56. We are persuaded by Petitioner’s analysis and find Petitioner has shown that this limitation would have been obvious over the combined teachings of Hibino and McMurray. *See* Pet. 57–58, 71; Ex. 1002 ¶¶ 140–143, 171.

Dependent claims 9 and 22 depend from claims 7 and 21 respectively and add “wherein a value of resistance of the dissipative element is selected to prevent degradation of the at least one switching element.”²⁹ Ex. 1001,

²⁷ Claim 20’s added limitation substantively similar—“further comprising generating the regulated voltage through controlled closing and opening of at least one switch element.” Ex. 1001, 21:50–52.

²⁸ Claim 21’s added limitation substantively similar—“wherein a value of resistance of the dissipative element is selected to suppress ringing of the regulated voltage during a switching period of the at least one switching element.” Ex. 1001, 21:53–56.

²⁹ Claim 22’s added limitation substantively similar—“wherein at least one characteristic of the dissipative element is additionally selected to prevent

Case IPR2017-00705
Case IPR2017-00706
Case IPR2017-01123
Patent 8,233,250 B2

21:1–3, 21:57–59. We are persuaded by Petitioner’s analysis and find Petitioner has shown that this limitation would have been obvious over the combined teachings of Hibino and McMurray. *See* Pet. 58–59, 72; Ex. 1002 ¶¶ 144, 172.

Dependent claims 10 and 23 depend from claims 7 and 21 respectively and add “wherein the at least one switching element comprises a plurality of switching block segments.”³⁰ Ex. 1001, 21:4–6, 21:60–62. We are persuaded by Petitioner’s analysis and find Petitioner has shown that this limitation would have been obvious over the combined teachings of Hibino and McMurray. *See* ’706 Pet. 51, 65; ’706 Ex. 1102 ¶¶ 132, 155.

Dependent claims 11 and 24 depend from claims 10 and 23 respectively and add “wherein at least a portion of the voltage spike protection circuitry is located between the plurality of switching block segments.” Ex. 1001, 21:7–9, 21:63–65. We find Hibino’s Figure 4 discloses several snubber circuits 300 next to a series circuit 170 that it protects. Ex. 1005, ¶ 76, Fig. 4; *see also* Figs. 7, 9. We are persuaded by Petitioner’s analysis and find Petitioner has shown that this limitation would have been obvious over the combined teachings of Hibino and McMurray.

degradation of the at least one switch element.” Ex. 1001, 21:57–59.

³⁰ Claim 23’s added limitation substantively similar—“wherein at least one switch element is segmented into a plurality of switching block segments.” Ex. 1001, 21:60–62.

Case IPR2017-00705
Case IPR2017-00706
Case IPR2017-01123
Patent 8,233,250 B2

See '706 Pet. 52–54, 65; '706 Ex. 1102 ¶¶ 133–135, 156.

Dependent claims 12 and 25 depend from claims 10 and 23 respectively and add “wherein charge-storage circuit comprises charge-storage circuit segments, and each charge-storage circuit segment of the spike protection circuit is physically closer to the switching block segment it protects than any other switching block segment.”³¹ Ex. 1001, 21:10–14, 21:66–22:2. In addition to the disclosure of Figure 4 discussed above with respect to claims 11 and 24, Hibino discusses the advantages of placing snubber circuits close to the switching circuitry it protects. Ex. 1005 ¶¶ 7, 70. We agree with Petitioner that given Hibino’s disclosure, a person of ordinary skill in the art would have understood each snubber circuit of Figure 4 should be placed more closely to the switch it protects than any other switch. '706 Pet. 55; '706 Ex. 1102 ¶¶ 136–137. We are persuaded by Petitioner’s analysis and find Petitioner has shown that this limitation would have been obvious over the combined teachings of Hibino and McMurray. *See* '706 Pet. 54–58, 65–66; '706 Ex. 1102 ¶¶ 136–140, 157.

³¹ Claim 25’s added limitation substantively similar—“wherein each charge-storage circuit segment of the spike protection circuit is physically closer to the switching block segment it protects than any other switching block segment.” Ex. 1001, 21:66–22:2.

Case IPR2017-00705
Case IPR2017-00706
Case IPR2017-01123
Patent 8,233,250 B2

j. Conclusion

We have considered the entirety of the evidence submitted by the parties, both for and against obviousness, and determine that Petitioner has shown, by a preponderance of the evidence, that claims 1–4, 7–17, 20–26, and 29 of the '250 patent would have been obvious over the combined teachings of Hibino and McMurray.

D. Obviousness over Hibino

Petitioner asserts that claims 28 and 31 would have been obvious under 35 U.S.C. § 103(a) as obvious over the teachings of Hibino. '706 Pet. 72–74. Patent Owner disagrees. '706 PO Resp. 71–77. We have considered Petitioner's argument and supporting evidence, including Dr. Leeb's testimony, regarding claims 28 and 31 of the '250 patent. '706 Pet. 72–74; '706 Ex. 1102 ¶¶ 167–176. We find that Petitioner has shown, by a preponderance of the evidence, that all the limitations of independent claims 28 and 31 are taught by Hibino. Other than making the same arguments regarding voltage spike circuitry considered and rejected above in Section II.C.5.c, Patent Owner does not specifically address the limitations of independent claims 28 and 31.

Claims 28 and 31 recite a “voltage regulator” and a “method of generating a regulated voltage” comprising “regulator circuitry generating a regulated voltage.” Ex. 1001, 22:39–41; 24:1–4. For the reasons discussed above (Sections II.C.5.a and II.C.5.b) with respect to independent claims 1,

Case IPR2017-00705
Case IPR2017-00706
Case IPR2017-01123
Patent 8,233,250 B2

13, 26, and 29, which contain substantially similar limitations, we find that Hibino teaches these limitations. *See* '706 Pet. 72–74; '706 Ex. 1102 ¶¶ 167–168, 172–173.

Claims 28 and 31 recite “voltage spike protection circuitry” comprising “a dissipative element and a charge-storage circuit.” Ex. 1001, 22:42–44, 24:5–8. For the reasons discussed above (Section II.C.5.c) with respect to independent claims 1, 13, 26, and 29, which contain substantially similar limitations, we find that Hibino teaches these limitations. *See* '706 Pet. 73–74; '706 Ex. 1102 ¶¶ 169, 174.

Claims 28 and 31 recite “at least one switching element, wherein the at least one switching element comprises a plurality of switching block segments.” Ex. 1001, 22:45–47, 24:9–11. For the reasons discussed above (Section II.C.5.i) with respect to dependent claims 10 and 23, which contain substantially similar limitations, we are persuaded by Petitioner’s analysis and find that Hibino teaches these limitations. *See* '706 Pet. 73–74; '706 Ex. 1102 ¶¶ 170, 175.

Finally, claims 28 and 31 recite “the charge-storage circuit comprises charge-storage circuit segments, and each charge-storage circuit segment of the spike protection circuit is physically closer to the switching block segment it protects than any other switching block segment.” Ex. 1001, 22:48–52, 24:12–16. For the reasons discussed above (Section II.C.5.i) with respect to dependent claims 12 and 25, which contain substantially similar

Case IPR2017-00705
Case IPR2017-00706
Case IPR2017-01123
Patent 8,233,250 B2

limitations, we are persuaded by Petitioner’s analysis and find that Hibino teaches these limitations. *See* ’706 Pet. 73–74; ’706 Ex. 1102 ¶¶ 171, 176.

We have considered the entirety of the evidence submitted by the parties, both for and against obviousness, and determine that Petitioner has shown, by a preponderance of the evidence, that claims 28 and 31 of the ’250 patent would have been obvious over the combined teachings of Hibino and McMurray.

E. Obviousness over Hibino, McMurray, and Wong

Petitioner asserts that claims 5, 6, 18, 19, 27, and 30 would have been obvious under 35 U.S.C. § 103(a) as obvious over the teachings of Hibino, McMurray, and Wong. ’1123 Pet. 35–76. Patent Owner disagrees. ’1123 PO Resp. 59–85. We have considered Petitioner’s argument and supporting evidence, including Dr. Leeb’s testimony, regarding claims 5, 6, 18, 19, 27, and 30 of the ’250 patent. ’1123 Pet. 61–71, 73–76; ’1123 Ex. 1402 ¶¶ 149–162, 168–177. As discussed in detail below, we find that Petitioner has shown, by a preponderance of the evidence, that all the limitations of claims 5, 6, 18, 19, 27, and 30 are taught by a combined teachings of Hibino, McMurray, and Wong and has provided sufficiently “articulated reasoning,” with “rational underpinning” and evidentiary support, to combine the teachings of these references to predictably yield the recited systems and methods. *See KSR*, 550 U.S. at 418 (quoting *Kahn*, 441 F.3d at 988).

Case IPR2017-00705
Case IPR2017-00706
Case IPR2017-01123
Patent 8,233,250 B2

1. *Overview of Wong*

Wong is titled “High Voltage Differential Sensor Having a Capacitive Attenuator.” Ex. 1430, (54). Specifically, Wong discusses high-voltage differential sensors, which are used in high-voltage power supply circuits to sense the voltage difference between two lines. *Id.* at 1:9–16. Wong’s high-voltage differential sensor employs “an attenuator having matched monolithic capacitor divider networks, with each network including a series connection of matched monolithically integrated capacitors.” *Id.* at 1:43–49. Wong’s Figure 2 shows this series-connected monolithically integrated capacitors made of polysilicon layers separated by oxide made using “standard MOS technology.” *Id.* at Fig. 2, 3:30–39, 4:1.

2. *Combined teachings of Hibino, McMurray, and Wong*

Petitioner asserts that a person of ordinary skill in the art would have been motivated to combine Wong with the circuit created using the teachings of Hibino and McMurray. ’1123 Pet. 57–61. Petitioner provides several reasons for this motivation. *Id.* For example, Petitioner explains that Hibino, itself, describes that its “switching devices can be implemented using MOSFET transistors, and thus, that its circuit can be implemented using MOS technology.” *Id.* at 57 (citing Ex. 1405 ¶¶ 60, 100). Moreover, according to Petitioner, at the time of the invention, “one of ordinary skill implementing the circuit design of Hibino would have readily done so using MOST technology” because “MOS technology predominated the field of

Case IPR2017-00705
Case IPR2017-00706
Case IPR2017-01123
Patent 8,233,250 B2

circuit design at that time and was a well-known, popular integrated circuit manufacturing technique.” *Id.* (citing Ex. 1434 (2005 textbook, *CMOS: Circuit Design, Layout, and Simulation*), 1; Ex. 1402 ¶ 144). In addition, Petitioner explains that capacitor 301 of Hibino’s snubber circuit is operable at high temperatures and one of ordinary skill would have been motivated to implement as much of that circuit as possible using the same fabrication process to reduce cost and size. *Id.* at 57–58 (citing Ex. 1405 ¶¶ 54, 72; Ex. 1421 (2000 textbook, *Electronics*), 16, 74; Ex. 1430, 4:1–2; Ex. 1402 ¶ 145).

Patent Owner argues that Hibino and Wong “address different and incompatible technologies” “to the different problems they address,” asserting that “[t]he combination of the two would be incompatible and would [] certainly not yield predictable results.” ’1123 PO Resp. 77, 80–85 (citing Ex. 2408 ¶ 153)³². According to Patent Owner, Hibino solves the problem of an upper limit of an allowable temperature of a capacitor by using snubber circuits comprised of high-temperature devices such as ceramic or film capacitors. *Id.* at 81–82. On the other hand, Patent Owner explains, Wong discloses a differential sensor operating with standard silicon processes. *Id.* at 83–84. Patent Owner asserts that “[a] POSITA would not look to the capacitors in Wong’s sensor operating with standard silicon processes when concerned with Hibino.” *Id.* at 84–85. In fact,

³² Patent Owner cites to paragraph 153 of Ex. 2408 (’1123 PO Resp. 84), but this Exhibit ends at paragraph 152.

Case IPR2017-00705
Case IPR2017-00706
Case IPR2017-01123
Patent 8,233,250 B2

Patent Owner asserts that Hibino *expressly teaches away* from using silicon because of the temperature issue. *Id.*

For the reasons discussed above in Section II.C.5.f, the evidence supports a finding that a person of ordinary skill in the art would have been motivated to combine McMurray's equations for a resistance value with Hibino's circuit.

For similar reasons, we find that a person of ordinary skill in the art would have been motivated to use Wong's capacitor in Hibino's snubber. Patent Owner's argument regarding incompatible solutions and unpredictable results assumes a requirement of bodily incorporation of Wong's differential sensors into Hibino circuitry. This, however, is not consistent with Petitioner's assertions. Instead, the Petition's proposed modification is aimed at extending to Hibino's circuitry using Wong's teaching of using MOS technology to fabricate series capacitors. *See* '1123 Pet. 56–61; '1123 Reply 24. As a result, we are persuaded that the combination proposed by Petitioner is proper. We also agree with Petitioner that Hibino teaches using MOSFETs generally. *See* '1123 Pet. 56–61; '1123 Reply 24; Ex. 1453 ¶ 73.

Therefore, based on the evidence before us, we are persuaded that a person of ordinary skill in the art would have found it obvious to apply Wong's teaching of using MOS technology to fabricate the capacitors in

Case IPR2017-00705
Case IPR2017-00706
Case IPR2017-01123
Patent 8,233,250 B2

Hibino's circuitry.

3. Claims 1 and 13

For the reasons discussed above in Section II.C.5, Petitioner has shown by a preponderance of the evidence, that claims 1 and 13 would have been obvious over a combined teachings of Hibino and McMurray.

4. Claims 5 and 18

Claims 5 and 18 depend from claims 1 and 13 respectively and recite “further comprising at least one MOS structure, wherein the MOS structure comprises the charge-storage circuit and at least a portion of the dissipative element.”³³ Ex. 1001, 20:54–57; 21:42–44.

Petitioner relies on Wong for the additional limitations of claim 5 and 18. '1123 Pet. 61–67, 73; '1123 Ex. 1402 ¶¶ 149–155, 168. Specifically, Petitioner asserts that a person of ordinary skill would have understood that the combined teachings of Hibino and Wong teaches the “MOS structure” recited in claims 5 and 18, including Wong's polysilicon capacitor and resistor. '1123 Pet. 63–65, 73; '1123 Ex. 1402 ¶¶ 149–155, 168. Petitioner explains, and supports with objective evidence, that this would reduce complexity, size, and cost. *Id.*; '1123 Reply 20 (citing '1123 Ex. 1455, 106:15–20, 116:11–117:2; '1123 Ex. 1453 ¶ 64).

³³ Claim 18's language is substantially similar, “wherein at least one MOS structure includes the charge-storage circuit and at least a portion of the dissipative element.” Ex. 1001, 21:42–44.

Case IPR2017-00705
Case IPR2017-00706
Case IPR2017-01123
Patent 8,233,250 B2

Patent Owner argues that Wong “does not disclose any MOS structure which comprises a portion of the dissipative element” and asserts that Petitioner “identifies no reason why a POSITA would have implemented a polysilicon resistor as part of a MOS structure in 2009” or “why a MOS structure would reduce complexity, size or cost relative to *any other arrangement.*” ’1123 PO Resp. 74 (citing ’1123 Ex. 2408 ¶ 132).³⁴

We credit Dr. Leeb’s testimony and the objective evidence he refers to on this issue. ’1123 Ex. 1402 ¶¶ 149–155 (citing Exs. 1432, 1433). We are not persuaded to the contrary by Dr. Pedram’s conclusory testimony, which does not address the objective evidence (e.g. textbooks ’1123 Exs. 1432, 1433) relied upon by Dr. Leeb. Ex. 2408 ¶¶ 128–131. Moreover, Dr. Pedram, in deposition testimony, appears to agree with Dr. Leeb’s reasoning. *See* ’1123 Ex. 1455, 106:15–20 (answering that a benefit of combining components on an integrated circuit would be “[c]ompactness, cost – lower cost and more efficiency”), 116:11–117:2 (“Cost is one factor. There are other factors that may override this consideration, but certainly from a cost perspective it’s best to work with the homogeneous fabric comprising of, say, CMOS components and other elements than to switch between different fabrication processes or try to integrate different fabrication processes.”).

³⁴ Although Patent Owner cites to paragraph 132 here (’1123 PO Resp. 74), we presume they meant to cite to paragraphs 128–131.

Case IPR2017-00705
Case IPR2017-00706
Case IPR2017-01123
Patent 8,233,250 B2

We are persuaded by Petitioner’s analysis and find Petitioner has shown that this limitation would have been obvious over the combined teachings of Hibino and Wong. *See* ’1123 Pet. 61–67, 73; ’1123 Ex. 1402 ¶¶ 149–155, 168.

5. Claims 6 and 19

Claims 6 and 19 depend from claims 1 and 13 respectively and recite “wherein [the] charge-storage circuit comprises a plurality of MOS capacitors connected in series, wherein a voltage across each MOS capacitor is maintained below a predetermined threshold as determined by a maximum allowed DC voltage of each MOS capacitor.” Ex. 1001, 20:58–62, 21:45–49. We are persuaded by Petitioner’s analysis and find Petitioner has shown that this limitation would have been obvious over the combined teachings of Hibino and Wong. *See* ’1123 Pet. 67–72, 73; ’1123 Ex. 1402 ¶¶ 157–162, 168. Patent Owner does not explicitly address the additional limitation of claims 6 and 19.

6. Claims 27 and 30

Claims 27 and 30 are independent and recite a ““voltage regulator” and “[a] method of generating a regulated voltage” comprising “regulator circuitry generating a regulated voltage.” Ex. 1001, 22:28–30; 23:7–10. For the reasons discussed above (Sections II.C.5.a and II.C.5.b) with respect to independent claims 1, 13, 26, and 29, which contain substantially similar

Case IPR2017-00705
Case IPR2017-00706
Case IPR2017-01123
Patent 8,233,250 B2

limitations, we find that Hibino teaches these limitations. *See* '1123 Pet. 74–75; '1123 Ex. 1402 ¶¶ 170–171, 174–175.

Claims 27 and 30 recite “voltage spike protection circuitry” comprising “a dissipative element and a charge-storage circuit.” Ex. 1001, 22:31–32, 23:11–14. For the reasons discussed above (Section II.C.5.c) with respect to independent claims 1, 13, 26, and 29, which contain substantially similar limitations, we find that Hibino teaches these limitations. *See* '1123 Pet. 74–75; '1123 Ex. 1402 ¶¶ 172, 176.

Finally, claims 27 and 30 recite “the charge-storage circuit comprises a plurality of MOS capacitors connected in series, wherein a voltage across each MOS capacitor is maintained below a predetermined threshold as determined by a maximum allowed DC voltage of each MOS capacitor.” Ex. 1001, 22:34–38, 23:14–18. For the reasons discussed above with respect to dependent claims 6 and 19, which contain substantially similar limitations, we are persuaded by Petitioner’s analysis and find that these limitations are taught by the combined teachings of Hibino and Wong. *See* '1123 Pet. 74–76; '1123 Ex. 1402 ¶¶ 173, 177.

7. Conclusion

We have considered the entirety of the evidence submitted by the parties, both for and against obviousness, and determine that Petitioner has shown, by a preponderance of the evidence, that claims 5, 6, 18, 19, 27, and

Case IPR2017-00705
Case IPR2017-00706
Case IPR2017-01123
Patent 8,233,250 B2

30 of the '250 patent would have been obvious over the combined teachings of Hibino, McMurray, and Wong.

III. PATENT OWNER'S MOTION TO AMEND

We have concluded that claims 1–31 of the '250 patent are unpatentable. Therefore, we address Patent Owner's contingent motion to substitute claims 32–62 for claims 1–31. Paper 30 ("MTA"); '706 Paper 66 ("706 MTA"); '1123 Paper 30 ("1123 MTA"). The parties submitted full briefing on Patent Owner's Motion to Amend in all three cases. Paper 49 ("Opp. MTA"); Paper 58 ("Reply MTA"); Paper 69 ("Sur-Reply MTA"); '706 Paper 49 ("706 Opp. MTA"); '706 Paper 58 ("706 Reply MTA"); '706 Paper 69 ("706 Sur-Reply MTA"); '1123 Paper 49 ("1123 Opp. MTA"); '1123 Paper 58 ("1123 Reply MTA"); '1123 Paper 69 ("1123 Sur-Reply MTA").

A. Proposed Substitute Claims

Patent Owner proposes to substitute claims 32–62 for claims 1–31. Substitute claims 32–62 represent a one-for-one substitution for original claims 1–31 in compliance with 37 C.F.R § 42.121(a)(3).

Proposed substitute claim 32 is reproduced below, with added text underlined and deleted text stricken through. MTA, App'x A.

~~432~~. A voltage regulator, comprising:

regulator circuitry generating a regulated voltage from a first power supply and a second power supply;

wherein the regulated voltage is a DC voltage;

Case IPR2017-00705
Case IPR2017-00706
Case IPR2017-01123
Patent 8,233,250 B2

voltage spike protection circuitry for voltage-spike-protecting the regulator circuitry, comprising a dissipative element and a charge-storage circuit;

wherein the voltage spike protection circuitry is on the same CMOS integrated circuit as switching circuitry of the regulator circuitry;

wherein a value of resistance of the dissipative element is based on a characteristic impedance of a lumped-element approximation of a transmission line,

wherein the transmission line comprises the charge-storage circuit and a parasitic inductance associated with the regulator circuitry.

Proposed substitute claim 32 amends original claim 1 to specify that 1) the regulated voltage be a DC voltage and 2) the voltage spike protection circuitry be on the same CMOS integrated circuit as the switching circuitry of the regulator circuitry. MTA 2. Each of proposed substitute claims 44 and 57–62, amend, by inserting these same limitations, original claims 13, 26–31 respectively. *Id.*; '706 MTA 2; '1123 MTA 2. Proposed substitute claim 58 further adds a requirement that “the intermediate node between the series MOS structures is connected to a bias network.” '1123 MTA 2.

Proposed substitute claims 33–43 depend from claim 32 and update claim dependencies to correspond to substitute claim numbers. MTA 2; '706 MTA 2; '1123 MTA 2–3. In addition, proposed substitute claims 33, 35, and 37–39 add further limitations, which are discussed in more detail below. MTA 2; '706 MTA 2; '1123 MTA 2–3. Proposed substitute claims

Case IPR2017-00705
Case IPR2017-00706
Case IPR2017-01123
Patent 8,233,250 B2

45–56 depend from claim 44 and update claim dependencies to correspond to substitute claim numbers. MTA 2; '706 MTA 2; '1123 MTA 2–3. In addition, proposed substitute claims 45, 48, and 50–52 add further limitations, which are discussed in more detail below. MTA 2; '706 MTA 2; '1123 MTA 2–3.

B. Requirements of U.S.C. § 316(d) and 37 C.F.R. § 42.121

Pursuant to 35 U.S.C. § 316(d)(3), “[a]n amendment under this subsection may not enlarge the scope of the claims of the patent or introduce new matter.” *See Aqua Prods., Inc. v. Matal*, 872 F.3d 1290, 1340–41 (Fed. Cir. 2017) (“Part III of this opinion sets forth the judgement of this court on what the Board may and may not do with respect [to] the burden of production on remand in this case,” and “[t]here is no disagreement that the patent owner bears a burden of production in accordance 35 U.S.C. § 316(d).”); *see also, e.g., id.* at 1305–06 (explaining that “patent owner must satisfy the Board that the statutory criteria in § 316(d)(1)(a)–(b) and § 316(d)(3) are met and that any reasonable procedural obligations imposed by the Director are satisfied”). Similarly, 37 C.F.R. § 42.121(a)(2)(ii) provides that a motion to amend may be denied where the amendment seeks to enlarge the scope of the claims of the patent or introduces new subject matter. *See* “Guidance on Motions to Amend in view of *Aqua Products*” (“Guidance”) (Nov. 21, 2017)

https://www.uspto.gov/sites/default/files/documents/guidance_on_motions

Case IPR2017-00705
Case IPR2017-00706
Case IPR2017-01123
Patent 8,233,250 B2

[to amend 11 2017.pdf](#)) (stating that, in addition to the requirements of 35 U.S.C. § 316(d), a motion to amend must meet the requirements of 37 C.F.R. § 42.121). In addition, with its motion to amend, a patent owner must set forth “support in the original disclosure of the patent for each claim that is added or amended.” 37 C.F.R. § 42.121(b)(1).

Patent Owner argues that all of the proposed substitute claims narrow, and do not broaden, the original claims. MTA 2; ’706 MTA 2–3; ’1123 MTA 2–3. Petitioner, however, argues that Patent Owner’s proposed amended claims 33, 37, 45, 50, and 58 impermissibly broaden the scope of the original claims, which they substitute. Opp. MTA, 2–7; ’1123 Opp. MTA, 3–6. In addition, Petitioner argues that claims 33, 35, 37, 45, 48, 50, and 58 are inconsistent with and/or unsupported by the Specification. Opp. MTA 7–11, 20; ’1123 MTA 7–9.

Because we find, below, that all of the proposed substitute claims are unpatentable over the prior art of record, we do not reach these arguments regarding broadening of original claims and whether the proposed amended claims are supported by the specification.

C. Patentability

Patent Owner does not have the burden of persuasion with respect to the patentability of substitute claims presented in its Motion to Amend. *See Aqua Products*, 872 F.3d at 1327; *see also* Guidance. The burden of persuasion to demonstrate the patentability of substitute claims presented in

Case IPR2017-00705
Case IPR2017-00706
Case IPR2017-01123
Patent 8,233,250 B2

a motion to amend will ordinarily lie with the petitioner. *See Aqua Products*, 872 F.3d at 1325–26; *see also Western Digital Corp. v. Spex Techs., Inc.*, IPR2018-00082, Paper 13 (PTAB April 25, 2018) (designated informative). For the reasons explained below, considering the entirety of the record before us, we determine that Petitioner has shown, by a preponderance of the evidence, that the proposed substitute claims are not patentable over the prior art of record. Patent Owner does not address secondary considerations with respect to the proposed substitute claims. *See* MTA; Reply MTA. To the extent the secondary considerations raised in arguing the patentability of the original claims also apply here, we adopt our analysis from Section II.C.5.g, above, and conclude that evidence as providing minimal, if any, support for nonobviousness and would not have caused the entirety of the evidence, both for and against obviousness, to weigh in favor of nonobviousness.

1. *Proposed Substitute Claims 32, 34, 36, 40–44, 46, 47, 49, 53–57, and 59–62*

Each of proposed substitute independent claims 32, 44, 57, and 59–62 amend original claims 1, 13, 26, and 28–31 by adding two additional limitations 1) “wherein the regulated voltage is a DC voltage,” and 2) “wherein the voltage spike protection circuitry is on the same CMOS integrated circuit as switching circuitry of the regulator circuitry.” MTA 4–8; ’706 MTA 4–8; ’1123 MTA 4–7. Proposed substitute claims 34, 36, 40–43, 46, 47, 49, and 53–56 depend from either claim 32 and 44 and amend

Case IPR2017-00705
Case IPR2017-00706
Case IPR2017-01123
Patent 8,233,250 B2

original claims 3, 5, 9–12, 15, 16, 18, and 22–25 respectively. Other than updating the claim dependencies, proposed substitute dependent claims 34, 36, 40–43, 46, 47, 49, and 53–56 are identical to the original corresponding claims 3, 5, 9–12, 15, 16, 18, and 22–25. MTA 4–8; '706 MTA 4–8; '1123 MTA 4–7. Above, in Sections II.C.5.h, II.C.5.i, II.D, and II.E, we determine original claims 1, 3, 5, 9–13, 15, 16, 18, 22–26, and 28–31 would have been obvious (1) over Hibino alone, (2) over Hibino and McMurray, and (3) over Hibino, McMurray, and Wong.

Petitioner argues that even with both additional limitations, given the obviousness of the original claims, the proposed substitute claims would have been obvious over the combined teachings of Hibino and McMurray. Opp. MTA 13–18; '706 Opp. MTA 2–9; '1123 Opp. MTA 17–20. According to Petitioner, DC voltage regulators were well-known in the art. MTA 14–17. In fact, Petitioner notes that the '250 patent, itself describes “most battery-operated consumer electronics devices us[ing] DC-DC regulators.” *Id.* at 14 (quoting Ex. 1001, 1:16–19; Ex. 1044 ¶¶ 33–35). Moreover, Petitioner adds that the added limitation requiring the voltage spike protection circuitry to be on the same CMOS integrated circuit as the switching circuitry would have been obvious over the combined teachings of Hibino and McMurray. *Id.* at 17–20.

Patent Owner disagrees, reiterating its argument, analyzed above in Section II.C.5.c, that the prior art does not show snubber circuitry on the

Case IPR2017-00705
Case IPR2017-00706
Case IPR2017-01123
Patent 8,233,250 B2

same chip or integrated circuit as the regulator circuitry. '706 Reply MTA 1–3; '1123 Reply MTA 10–12.³⁵ As explained in that same section, we do not agree with Patent Owner's characterization of the prior art, and instead find that Hibino discloses both the voltage spike protection and regulator circuitry to be on the same chip. Thus, we agree with Petitioner that Patent Owner's added limitation does not prevent claims 33 and 45 from being obvious over Hibino and McMurray.

Patent Owner does not appear to rely on the added limitation “wherein the regulated voltage is a DC voltage,” as altering the patentability analysis of the original claims. *See* MTA; '706 MTA, '1123 MTA (none of which address this limitation). We agree that DC voltage regulators were well-known in the art. *See* Pet. 15–18; Opp. MTA 13–14; Ex. 1001, 1:16–19; Ex. 1044 ¶¶ 33–36. And we agree that a person of ordinary skill in the art would have been motivated to implement Hibino's voltage spike protection circuitry on the same integrated circuit as the switching circuitry with a reasonable expectation of success. *See* Opp. MTA 15–18; Ex. 1044 ¶¶ 39–43.

³⁵ In the reply brief supporting its motion to amend in IPR2017-00705, Patent Owner does not discuss obviousness over Hibino and McMurray, but instead discusses Shekhawat, prior art at issue in the other cases, but not IPR2017-00705. Reply MTA 8–11. We, therefore, rely on Patent Owner's arguments in IPR2017-00706 and IPR2017-00708 and apply them to the claims challenged in IPR2017-00705.

Case IPR2017-00705
Case IPR2017-00706
Case IPR2017-01123
Patent 8,233,250 B2

We have considered the entirety of the evidence submitted by the parties, both for and against obviousness, and determine that Petitioner has shown, by a preponderance of the evidence, that proposed substitute claims 32, 34, 36, 40–44, 46, 47, 49, 53–57, and 59–62 would have been obvious over the combined teachings of Hibino and McMurray.

2. *Proposed Substitute Dependent Claims 33 and 45*

Proposed substitute claims 33 and 45 depend from claims 32 and 44 and amend original claim 2 and claim 14 respectively. In addition to updating the claim dependencies, proposed substitute claims 33 and 45 add to the original claims the limitation “wherein the dissipative element comprises the equivalent series resistance of the charge storage circuitry associated with the charge storage circuit and the resistance associated with metal traces of the integrated circuit.” MTA 4, 6. Above, in Section II.C.5.i, we determine original claims 2 and 14 would have been obvious over Hibino and McMurray.

Petitioner argues that proposed substitute claims 33 and 45 would have been obvious over Hibino and McMurray because a person of ordinary skill would have known that physical devices such as capacitors and metal traces have equivalent series resistance and would have known how to calculate this resistance value. Opp. MTA 11–13 (citing Ex. 1002 ¶¶ 32, 34; Ex. 1034, 69:4–9; Ex. 1035, 2:42–44, 6:11–25; Ex. 1044 ¶ 31). According to Petitioner, a person of ordinary skill in the art “would have understood to include those values in the resistance calculation because ESR, when

Case IPR2017-00705
Case IPR2017-00706
Case IPR2017-01123
Patent 8,233,250 B2

considered in addition to the resistance of a resistor as required by the claims, can be relevant to the behavior of a circuit” and, therefore, would have considered these values in the calculation of the resistance value for Hibino’s circuit using McMurray’s equations. *Id.* at 13 (citing Ex. 1037; Ex. 1003, 593; Ex. 1044 ¶ 32).

Patent Owner disagrees, reiterating its argument, analyzed above in Section II.C.5.d, that the prior art does not disclose a resistance value “based on a characteristic impedance of a lumped-element approximation of a transmission line, wherein the transmission line comprises the charge-storage circuit and a parasitic inductance associated with the regulator circuitry.”³⁶ Reply MTA 11. We analyzed this argument above, in Section II.C.5.d, with respect to the original claims. As explained in that same section, a person of ordinary skill in the art would have understood McMurray’s equations to be referring to the characteristic impedance of a transmission line and understood McMurray to teach reducing a complex circuit to an equivalent circuit thereby approximating lumped RLC elements of an ideal circuit to a non-ideal equivalent circuit wherein signals are transmitted from one source point to a destination point. We are persuaded

³⁶ In the reply Patent Owner does not discuss obviousness over Hibino and McMurray, but instead discusses Shekhawat, prior art at issue in the other cases, but not IPR2017-00705. Reply MTA 11. We assume this is an error and we apply Patent Owner’s arguments to Hibino as opposed to Shekhawat for purposes of this analysis.

Case IPR2017-00705
Case IPR2017-00706
Case IPR2017-01123
Patent 8,233,250 B2

by Petitioner’s analysis, and find Petitioner has shown that this limitation is taught by the combined teachings of Hibino and McMurray. *See* Opp. MTA 11–13; Ex. 1002 ¶¶ 32, 34; Ex. 1044 ¶¶ 31–32.

We have considered the entirety of the evidence submitted by the parties, both for and against obviousness, and determine that Petitioner has shown, by a preponderance of the evidence, that proposed substitute claims 33 and 45 would have been obvious over the combined teachings of Hibino and McMurray.

3. *Proposed Substitute Dependent Claims 35 and 48*

Proposed substitute claims 35 and 48 depend from claims 32 and 44 and amend original claims 4 and claims 17 respectively. In addition to updating the claim dependencies, proposed substitute claims 35 and 48 add to the original claims the limitation “wherein the voltage spike protection circuitry protects against spikes at the first power supply and the second power supply.” MTA 5– 6. Above, in Section II.C.5.i, we determine original claims 4 and 17 would have been obvious over Hibino and McMurray.

Petitioner argues that proposed substitute claims 35 and 48 would have been obvious over Hibino and McMurray because “[i]mplementing voltage spike protection circuitry to protect against spikes at multiple power supplies was well known” taught by Hibino’s Figure 4. Opp. MTA 21–22 (citing Ex. 1005, Fig. 4; Ex. 1044 ¶¶ 54–55).

Case IPR2017-00705
Case IPR2017-00706
Case IPR2017-01123
Patent 8,233,250 B2

In the Motion to Amend, Patent Owner submits that Hibino and McMurray fail to disclose the added limitation, stating that “these references disclose high voltage spikes at the *output*, e.g., load.” MTA 10. However, Patent Owner does not address the argument or evidence raised in Petitioner’s opposition brief. *See* Reply MTA 7–8 (arguing that proposed substitute claims 35 and 48 are supported by the specification, but nowhere addressing Petitioner’s obviousness contentions).

We are persuaded by Petitioner’s analysis, and find Petitioner has shown that this limitation is taught by the combined teachings of Hibino and McMurray. *See* Opp. MTA 21–22; Reply MTA 7–8; Ex. 1005, Fig. 4; Ex. 1044 ¶¶ 54–55; Ex. 1057 ¶¶ 17–18.

We have considered the entirety of the evidence submitted by the parties, both for and against obviousness, and determine that Petitioner has shown, by a preponderance of the evidence, that proposed substitute claims 35 and 48 would have been obvious over the combined teachings of Hibino and McMurray.

4. *Proposed Substitute Claims 37, 50, and 58*

Proposed substitute claims 37 and 50 depend from claims 32 and 44 and amend original claims 6 and 19 respectively. Independent claim 58 amends original claim 27. Each of proposed claims 37, 50, and 58 adds the additional limitation “wherein the intermediate node between the series MOS structures is connected to a bias network.” ’1123 MTA 5–7. Above,

Case IPR2017-00705
Case IPR2017-00706
Case IPR2017-01123
Patent 8,233,250 B2

in Section II.E, we determine original claims 6, 19, and 27 would have been obvious over Hibino, McMurray, and Wong.

Petitioner argues that these claims would have been obvious over the combined teachings of Hibino, McMurray, Wong, and Diorio.³⁷ '1123 Opp. MTA 10–12. Diorio is titled “High-Voltage CMOS-Compatible Capacitors” and describes a “high-voltage stacked capacitor [that] includes a first capacitor and a second capacitor,” each of which includes “a first semiconductive body” and a “floating electrode,” which “includes an intercapacitor node.” Ex. 1448, (54), (57). “In one embodiment, stacked capacitor 915 includes common node 925 comprising a floating gate, as described above, and is coupled to the charge injector 905 and to the charge drain 910.” *Id.* at 10:29–34. Dr. Leeb testifies that charge injector 905 and charge drain 910 teach a bias network. Ex. 1444 ¶ 26.

According to Petitioner, “it would have been obvious to a POSA implementing the series capacitors of Wong in Hibino to add a bias network at an intermediate node, as taught by Diorio” because at the relevant time, the technique was routinely “used to assure that capacitors behave in the desired manner (i.e., by properly dividing voltage among the capacitors).” '1123 Opp. MTA 11 (citing '1123 Ex. 1444 ¶ 27). Dr. Leeb testifies that a person of ordinary skill would have “understood that by using a bias

³⁷ U.S. Patent No. 6,842,327 B1 (“Diorio”). IPR2017-01123, Ex. 1448.

Case IPR2017-00705
Case IPR2017-00706
Case IPR2017-01123
Patent 8,233,250 B2

network, the reliability of the capacitors that were originally connected in series in Wong’s capacitive divider network could be enhanced and their consistent operation could be assured despite potential variations during fabrication.” ’1123 Ex. 1444 ¶ 29.

Patent Owner argues that Petitioner has not met its burden to show that proposed substitute claims 37, 50, and 58 would have been obvious. ’1123 Reply MTA 8–10. According to Patent Owner, Petitioner relies only on hindsight to argue that the combination is obvious. *Id.* at 9. In addition, Patent Owner argues that Petitioner’s argument based on what a person of ordinary skill in the art would have understood “should be procedurally barred under 35 U.S.C. § 311(b), which limits *inter partes* review to “ground[s] that could be raised under section 102 or 103 and *only on the basis of prior art consisting of patents or printed publications.*” *Id.*

We agree with Petitioner. First, we do not agree with Patent Owner’s procedural argument. Petitioner may rely the knowledge possessed by one with ordinary skill in the art to show the obviousness of the proposed claims. *See e.g., Merck Sharp & Dohme Corp. v. Hospira, Inc.*, 874 F.3d 724, 730–31 (Fed. Cir. 2017) (affirming obviousness where limitation would have been well known to POSA); *Arendi S.A.R.L. v. Apple Inc.*, 832 F.3d 1355, 1362 (Fed. Cir. 2016) (in IPR, “common sense” can “supply a [] missing limitation”); *Perfect Web Techs., Inc. v. InfoUSA, Inc.*, 587 F.3d 1324, 1328 (Fed. Cir. 2009).

Case IPR2017-00705
Case IPR2017-00706
Case IPR2017-01123
Patent 8,233,250 B2

Second, the disclosure of Diorio itself along with testimony by Dr. Leeb, shows that Diorio teaches a bias network and the potential benefit of adding such a network. '1123 Ex. 1448, 3:18–28, 10:29–34, 13:29–33; '1123 Ex. 1444 ¶¶ 26–29. Patent Owner does not sufficiently refute this evidence. Moreover, we note Dr. Leeb's unrebutted testimony that a person of ordinary skill in the art would have been motivated to use these teachings of Diorio to modify Hibino's disclosed circuitry. Ex. 1444 ¶¶ 26–29.

We have considered the entirety of the evidence submitted by the parties, both for and against obviousness, and determine that Petitioner has shown, by a preponderance of the evidence, that proposed substitute claims 37, 50, and 58 would have been obvious over the combined teachings of Hibino, McMurray, Wong, and Diorio.

5. *Proposed Substitute Claims 38 and 51*

Proposed substitute claims 38 and 51 depend from claims 32 and 44 and amend original claims 7 and claims 20 respectively. In addition to updating the claim dependencies, proposed substitute claims 38 and 51 add to the original claims the limitation "wherein the switching frequency of the regulator circuitry is greater than or equal to 10 MHz." MTA 5, 7. Above, in Section II.C.5.i, we determine original claims 7 and 20 would have been obvious over Hibino and McMurray.

Petitioner argues that proposed substitute claims 38 and 51 would have been obvious over Hibino and McMurray because "[i]mplementing a regulator with switching frequency that is greater than or equal to 10Mz was

Case IPR2017-00705
Case IPR2017-00706
Case IPR2017-01123
Patent 8,233,250 B2

well-known in the art” as acknowledged by the ’250 patent, which explains in the Background that switching frequencies in the tens to hundreds of MHz can be used. Opp. MTA 22 (citing Ex. 1001, 3:60–61); Ex. 1044 ¶ 59 *see also* Ex. 1039, (57) (patent issued in 1999). According to Petitioner, a person of ordinary skill “would have been further motivated to use Hibino with switches that operate at a switching frequency of 10 MHz or more to enable the circuitry to operate on chip with reduced energy storage elements” and that “operating a regulator at high switching frequency has several advantages, such as reducing the size of the output filter and allowing fast dynamic response.” *Id.* at 23–24 (citing Ex. 1043, 873, Ex. 1042); Ex. 1044 ¶ 60.

Patent Owner makes the same procedural argument that arguments about the knowledge of a person of skill in the art are barred as in Section III.C.4., above. Reply MTA 12. We reject this argument for the same reasons discussed above. In addition, Patent Owner argues that the prior art does not disclose any switching frequencies or regulated voltages and that Petitioner has not shown that any of the “newly cited art” that show the claimed ranges of frequencies “disclose the other limitations of the claims, that they are analogous art to the ’250 patent, or explained why a POSA would have looked to those particular references for guidance on appropriate

Case IPR2017-00705
Case IPR2017-00706
Case IPR2017-01123
Patent 8,233,250 B2

switching frequencies and regulated voltages” for the relevant circuit type.³⁸

Id.

We disagree that Petitioner’s reliance on Exhibits 1039, 1042, and 1043 was improper as these references constitute corroborating evidence of what a person of ordinary skill in the art would have known. *Ariosa Diagnostics v. Verinata Health, Inc.*, 805 F.3d 1359, 1365 (Fed. Cir. 2015) (“Art can legitimately serve to document the knowledge that skilled artisans would bring to bear in reading the prior art identified as producing obviousness.”). Moreover, we are persuaded by Petitioner’s analysis and find Petitioner has shown that the combined teachings of Hibino and McMurray teaches this limitation. *See* Opp. MTA 22–24; Ex. 1001, 3:60–61; Ex. 1005 ¶¶ 6, 54; Ex. 1039, (57); Ex. 1042; Ex. 1043, 873; Ex. 1044 ¶¶ 56–60.

We have considered the entirety of the evidence submitted by the parties, both for and against obviousness, and determine that Petitioner has shown, by a preponderance of the evidence, that proposed substitute claims 38 and 51 would have been obvious over the combined teachings of Hibino

³⁸ In the reply Patent Owner does not discuss obviousness over Hibino and McMurray, but instead discusses Shekhawat, prior art at issue in cases IPR2017-00707, -00708, and -01124, but not IPR2017-00705, -00706, or 01123. Reply MTA 11–12. We assume this is an error and we apply Patent Owner’s arguments to Hibino as opposed to Shekhawat for purposes of this analysis.

Case IPR2017-00705
Case IPR2017-00706
Case IPR2017-01123
Patent 8,233,250 B2

and McMurray.

6. *Proposed Substitute Claims 39 and 52*

Proposed substitute claims 39 and 52 depend from claims 38 and 51 and amend original claims 8 and 21 respectively. In addition to updating the claim dependencies, proposed substitute claims 39 and 52 add to the original claims the limitation “wherein the regulated voltage is 0.56-3.4 volts (DC).” MTA 5, 7. Above, in Section II.C.5.i, we determine original claims 8 and 21 would have been obvious over Hibino and McMurray.

Petitioner argues that proposed substitute claims 39 and 52 would have been obvious over Hibino and McMurray because “[i]mplementing a regulator providing a regulated voltage within 0.56-3.4 volts (DC) was well known in the art” as acknowledged by the ’250 patent. Opp. MTA 24 (citing Ex. 1001, 1:16–19; Ex. 1044 ¶¶ 61–64). Petitioner also offers evidence, in the form of multiple references, that this voltage range was well known to one with ordinary skill in the art. *Id.* (citing Ex. 1043, 876; Ex. 1041, 370). According to Petitioner, a person of ordinary skill “would have been motivated to implement Hibino’s regulator with the proposed voltage range” and that “Hibino expressly refers to the use of MOSFETs, which were known to operate within the claimed voltage range.” *Id.* at 25 (citing Ex. 1005 ¶¶ 54, 60, 100); Ex. 1044 ¶ 65.

Patent Owner makes the same arguments regarding proposed substitute claims 39 and 52 as it does for proposed substitute claims 38 and 51. Reply MTA 12. We reject these arguments for the reasons given above

Case IPR2017-00705
Case IPR2017-00706
Case IPR2017-01123
Patent 8,233,250 B2

in Section III.C.5.

We are persuaded by Petitioner’s analysis and find Petitioner has shown that this limitation is taught by the combined teachings of Hibino and McMurray. *See* Opp. MTA 24–25; Ex. 1001, 1:16–19; Ex. 1005 ¶¶ 54, 60, 100; Ex. 1041, 370; Ex. 1043, 876; Ex. 1044 ¶¶ 61–65.

We have considered the entirety of the evidence submitted by the parties, both for and against obviousness, and determine that Petitioner has shown, by a preponderance of the evidence, that proposed substitute claims 39 and 52 would have been obvious over the combined teachings of Hibino and McMurray.

IV. CONCLUSION

For the foregoing reasons, we determine that Petitioner has shown, by a preponderance of the evidence, that claims 1–31 would have been obvious.

In addition, we determine that Petitioner has shown, by a preponderance of the evidence, that proposed substitute claims 32–62 would have been obvious. We, therefore, deny Patent Owner’s Motion to Amend.

V. ORDER

Accordingly, it is

ORDERED that claims 1–31 of the ’250 patent are held *unpatentable*;

FURTHER ORDERED that Patent Owner’s Motion to Amend is *denied*;

FURTHER ORDERED that pursuant to 35 U.S.C. § 318(b), upon

Case IPR2017-00705
Case IPR2017-00706
Case IPR2017-01123
Patent 8,233,250 B2

expiration of the time for appeal of this Decision, or the termination of any such appeal, a certificate shall issue cancelling claims 1–31 in U.S. Patent No. 8,233,250 B2; and

FURTHER ORDERED that because this is a final written decision, parties to the proceeding seeking judicial review of the decision must comply with the notice and service requirements of 37 C.F.R. § 90.2.

Case IPR2017-00705
Case IPR2017-00706
Case IPR2017-01123
Patent 8,233,250 B2

For PETITIONER:

Richard Goldenberg
Donald Steinberg
Theodoros Konstantakopoulos
WILMER CUTLER PICKERING HALE & DORR LLP
richard.goldenberg@wilmerhale.com
don.steinberg@wilmerhale.com
theodoros.konstantakopoulos@wilmerhale.com

For PATENT OWNER:

James Glass
John McKee
QUINN EMANUEL URQUHART & SULLIVAN LLP
jimglass@quinnemanuel.com
johnmckee@quinnemanuel.com