

UNITED STATES PATENT AND TRADEMARK OFFICE

BEFORE THE PATENT TRIAL AND APPEAL BOARD

COMCAST CABLE COMMUNICATIONS, LLC,
Petitioner

v.

ROVI GUIDES, INC.,
Patent Owner

Case IPR2017-01049
Patent 8,578,413 B2

PATENT OWNER'S NOTICE OF APPEAL

Pursuant to 35 U.S.C. §§ 141, 142, and 319, and 37 C.F.R. §§ 90.2-90.3, notice is hereby given that Patent Owner Rovi Guides, Inc., appeals to the United States Court of Appeals for the Federal Circuit from the Final Written Decision of the Patent Trial and Appeal Board (“Board”) entered on October 16, 2018 (Paper 36) in IPR2017-01049, and from all underlying orders, decisions, rulings, and opinions. A copy of the Final Written Decision is attached.

In accordance with 37 C.F.R. § 90.2(a)(3)(ii), Patent Owner further indicates that the issues on appeal include, but are not limited to: (1) the Board’s determinations that (i) claims 1, 3–10, and 12–18 are unpatentable under 35 U.S.C. § 103(a) as obvious over Sato and Humpleman; and (ii) claims 2 and 11 are unpatentable under 35 U.S.C. § 103(a) as obvious over Sato, Humpleman, and Lawler; (2) the Board’s claim construction analysis and determinations; and (3) the Board’s authority, and all other issues decided adversely to Patent Owner in any order, decision, ruling or opinion underlying or supporting the Final Written Decision.

Pursuant to 35 U.S.C. § 142 and 37 C.F.R. § 90.2(a), this Notice is being filed with the Director of the United States Patent and Trademark Office, and a copy of this Notice is being concurrently filed with the Patent Trial and Appeal Board. In addition, a copy of this Notice and the required docketing fees are being filed with the Clerk’s Office for the United States Court of Appeals for the

Federal Circuit via CM/ECF.

Dated: December 7, 2018

Respectfully submitted,

ROPES & GRAY LLP

By: */Mark Rowland/*
Mark D. Rowland
Reg. No. 32,077
ROPES & GRAY LLP
1900 University Ave., 6th Floor
East Palo Alto, CA 94303-2284
T: 650-617-4016
F: 617-235-9492
Mark.Rowland@ropesgray.com

CERTIFICATE OF FILING

It is certified that, in addition to being filed electronically through the Patent Trial and Appeal Board's E2E System, a true and correct copy of the foregoing PATENT OWNER'S NOTICE OF APPEAL has been filed by hand on December 7, 2018, with the Director of the United States Patent and Trademark Office, at the following address:

Director of the United States Patent and Trademark Office
c/o Office of the General Counsel
10B20, Madison Building East,
600 Dulany Street
Alexandria, VA 22314-5793

Dated: December 7, 2018

Respectfully submitted,

By: /Mark Rowland/
Mark D. Rowland

CERTIFICATE OF FILING

It is certified that, a copy of the foregoing PATENT OWNER'S NOTICE OF APPEAL was filed electronically through the United States Court of Appeals for the Federal Circuit's CM/ECF system December 7, 2018 and one paper copy delivered by hand on December 7, 2018, with the Clerk of the Court of the Federal Circuit, at the following address:

Clerk of the Court
717 Madison Place, N.W.
Room 401
Washington D.C. 20439

Dated: December 7, 2018

Respectfully submitted,

By: /Mark Rowland/
Mark D. Rowland

CERTIFICATE OF SERVICE

The undersigned certifies that a true and correct copy of the foregoing PATENT OWNER'S NOTICE OF APPEAL was served by filing this document through the Patent Trial and Appeal Board End to End (PTAB E2E) as well as providing a courtesy copy via e-mail to the following attorneys of record for the Petitioner listed below:

Lead Counsel:	Frederic M. Meeker (Reg. No. 35,282) BANNER AND WITCOFF, LTD 1100 13 th Street, NW, Suite 1200 Washington, DC 20005 T: 202-824-3000 fmeeker@bannerwitcoff.com
Back-up Counsel:	Bradley C. Wright (Reg. No. 38,061) bwright@bannerwitcoff.com Scott M. Kelly (Reg. No. 65,121) skelly@bannerwitcoff.com Azuka C. Dike (Reg. No. 68,497) adike@bannerwitcoff.com Joshua Davenport (Reg. No. 72,756) jdavenport@bannerwitcoff.com Camille Sauer (Reg. No. 71,866) csauer@bannerwitcoff.com Bennett A. Ingvaldstad (Reg. No. 73,367) bingvaldstad@bannerwitcoff.com BANNER AND WITCOFF, LTD 1100 13th Street, NW, Suite 1200 Washington, DC 20005 T: 202-824-3000; F: 202-824-3001 ComcastIPRService@bannerwitcoff.com

Dated: December 7, 2018 By: /Mark Rowland/
Mark D. Rowland

UNITED STATES PATENT AND TRADEMARK OFFICE

BEFORE THE PATENT TRIAL AND APPEAL BOARD

COMCAST CABLE COMMUNICATIONS, LLC,
Petitioner,

v.

ROVI GUIDES, INC.,
Patent Owner.

Case IPR2017-01049
Patent 8,578,413 B2

Before KEVIN F. TURNER, MICHAEL R. ZECHER, and
JESSICA C. KAISER, *Administrative Patent Judges*.

TURNER, *Administrative Patent Judge*.

FINAL WRITTEN DECISION
Inter Partes Review
35 U.S.C. § 318(a) and 37 C.F.R. § 42.73

I. INTRODUCTION

Petitioner, Comcast Cable Communications, LLC (“Comcast”), filed a Petition requesting an *inter partes* review of claims 1–18 of U.S. Patent No. 8,578,413 B2 (Ex. 1101, “the ’413 Patent”). Paper 2 (“Pet.”). Patent Owner, Rovi Guides, Inc. (“Rovi”), filed a Preliminary Response. Paper 7. Taking into account the arguments presented in Rovi’s Preliminary Response, we determined that the information presented in the Petition established that there was a reasonable likelihood that Comcast would prevail in challenging claims 1–18 of the ’413 Patent as unpatentable under 35 U.S.C. § 103(a). Pursuant to 35 U.S.C. § 314, we instituted this *inter partes* review on October 18, 2017, as to all of the challenged claims, but not all the grounds presented by Comcast in its Petition. Paper 9 (“Dec. on Inst.”).

During the course of trial, Rovi filed a Patent Owner Response (Paper 15, “PO Resp.”), and Comcast filed a Reply to the Patent Owner Response (Paper 26, “Pet. Reply”). A consolidated oral hearing with related Cases IPR2017-00950, IPR2017-00951, IPR2017-00952, IPR2017-01048, IPR2017-01050, IPR2017-01065, IPR2017-01066, and IPR2017-01143 was held on June 19, 2018, and a transcript of the hearing is included in the record. Paper 35 (“Tr.”).

After all substantive briefing was complete, but before the consolidated oral hearing, the United States Supreme Court held that a decision to institute under 35 U.S.C. § 314 may not institute on less than all claims challenged in the petition. *SAS Inst., Inc. v. Iancu*, 138 S. Ct. 1348, 1359–60 (2018). Following *SAS*, the U.S. Patent and Trademark Office (“Office”) issued “Guidance on the impact of SAS on AIA trial

proceedings,” in which the Office took the policy position that a decision granting institution will institute on all of the challenged claims in the petition *and* all the grounds presented in the petition.¹ The U.S. Court of Appeals for the Federal Circuit has since endorsed this Office policy by explaining that “‘the petitioner’s petition, not the Director’s discretion, is supposed to guide the life of the litigation’ and ‘that the petitioner’s contentions, not the Director’s discretion define the scope of the litigation all the way from institution through to conclusion.’” *Adidas AG v. Nike, Inc.*, 894 F.3d 1256, 1258 (Fed. Cir. 2018) (quoting *SAS*, 138 S. Ct. at 1356–1357). In accordance with *SAS* and Office policy, we issued an Order modifying our Decision on Institution entered on October 18, 2017, to include review of all challenged claims and all grounds presented by Comcast in its Petition. Paper 32. The parties, however, agreed to waive briefing on the grounds we declined to institute in the Decision on Institution. *Id.* The parties also agreed to waive consideration of these previously non-instituted grounds at the consolidated oral hearing. *Id.*

We have jurisdiction under 35 U.S.C. § 6. This decision is a Final Written Decision under 35 U.S.C. § 318(a) as to the patentability of claims 1–18 of the ’413 Patent. For the reasons discussed below, we hold that Comcast has demonstrated by a preponderance of the evidence that these claims are unpatentable under § 103(a).

¹ Available at <https://www.uspto.gov/patents-application-process/patent-trial-and-appeal-board/trials/guidance-impact-sas-aia-trial>.

A. Related Matters

The '413 Patent is involved in the following district court cases: (1) *Rovi Guides, Inc. v. Comcast Corp.*, No. 2:16-cv-00322 (E.D. Tex.), which has been transferred to the U.S. District Court for the Southern District of New York and is pending as *Rovi Guides, Inc. v. Comcast Corp.*, No. 1:16-cv-09826 (S.D.N.Y.); and (2) *Comcast Corp. v. Rovi Corp.*, No. 1:16-cv-03852 (S.D.N.Y.). Pet. 1–2; Paper 3, 2. The '413 Patent also has been asserted against Comcast in a proceeding before the U.S. International Trade Commission (“ITC”) styled *In re Certain Digital Video Receivers and Hardware and Software Components Thereof*, No. 337-TA-1001. Pet. 2; Paper 3, 2.

In addition to this Petition, Comcast filed two other petitions challenging the patentability of claims 1–18 of the '413 Patent (Cases IPR2017-01048 and IPR2017-01050). Pet. 3; Paper 3, 2. Comcast also filed other petitions challenging the patentability of certain subsets of claims in several patents owned by Rovi. Pet. 3.

B. The '413 Patent

The '413 Patent, titled “Interactive Television Program Guide with Remote Access,” issued November 5, 2013, from U.S. Patent Application No. 13/275,565, filed on October 18, 2011. Ex. 1101, [54], [45], [21], [22]. The '413 Patent is a continuation of U.S. Patent Application No. 10/927,814, filed on August 26, 2004, which, in turn, is a continuation of U.S. Patent Application No. 09/354,344, filed on July 16, 1999. *Id.* at [63]. The '413 Patent also claims the benefit of U.S. Provisional Application No.

60/097,527, filed on August 21, 1998, and U.S. Provisional Application No. 60/093,292, filed on July 17, 1998. *Id.* at [60].

The '413 Patent generally relates to interactive television program guide video systems and, in particular, to such systems that provide remote access to program guide functionality. Ex. 1101, 1:16–19. The '413 Patent discloses that conventional interactive television program guide systems typically are implemented on set-top boxes located in the home of a user and, as a result, do not permit the user to perform program guide functions without the user being physically located in the same room as these systems. *Id.* at 1:34–42. Stated differently, conventional interactive television program guide systems require the user to be present in the home to access important program guide features, such as program reminders, parental controls, and program recording. *Id.* at 2:16–19. The '413 Patent purportedly addresses this and other problems by providing an interactive television program guide system that allows a user to access certain features of the program guide remotely and establish settings for those features. *Id.* at 2:20–25.

Figure 1 of the '413 Patent, reproduced below, illustrates a schematic block diagram of the system in accordance with the present invention. Ex. 1101, 7:15–39.

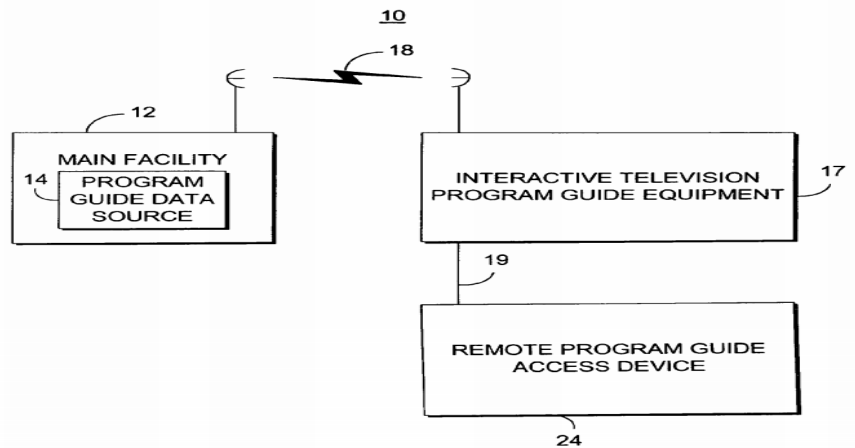

FIG. 1

As shown in Figure 1 reproduced above, system 10 includes main facility 12 that provides interactive television program guide data from program guide data source 14 to interactive television program guide equipment 17 via communication link 18. *Id.* at 7:15–22. Interactive television program guide equipment 17 is connected to at least one remote program guide access device 24 via remote access link 19. *Id.* at 7:33–35.

Figure 2a of the '413 Patent, reproduced below, illustrates one arrangement involving the interactive television program guide equipment 17 and remote program guide access device 24 in accordance with the principles of the present invention. Ex. 1101, 8:16–34.

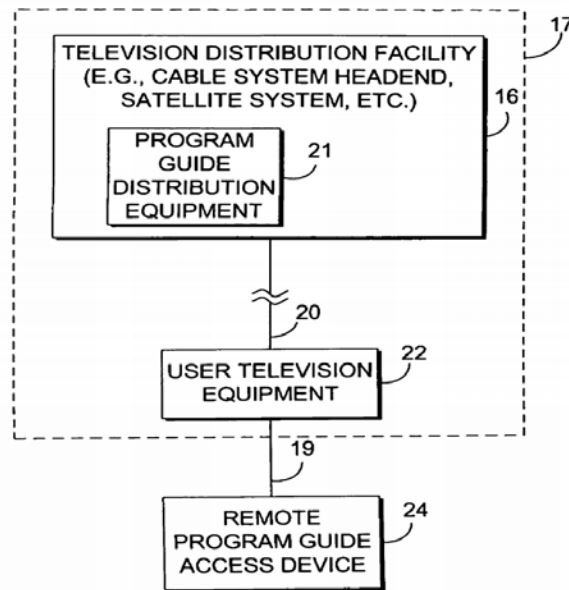

FIG. 2a

As shown in Figure 2a reproduced above, interactive television program guide equipment 17 includes program guide distribution equipment 21 located at television distribution facility 16, which distributes program guide data to user television equipment 22 via communications path 20. *Id.* at 4:57–67. Remote program guide access device 24 receives the program guide data, as well as any additional data necessary to access various functions of the interactive program guide, from user television equipment 22 via remote access link 19. *Id.* at 8:21–26.

In at least one embodiment, the '413 Patent discloses that a remote access interactive television program guide implemented on remote program guide access device 24 communicates with a local interactive television program guide implemented on interactive television program guide equipment 17. *Id.* at 15:9–18. In one example, the remote access and local interactive television program guides may be two different guides that communicate with each other. *Id.* at 15:20–23; *see also id.* at 25:35–59

(disclosing steps involved with using the remote access interactive television guide to provide program listing information to a user).

The '413 Patent discloses transferring program guide information and settings between remote program guide access device 24 and interactive television program guide equipment 17 using any suitable application layer protocol. Ex. 1101, 15:60–64. For example, if remote access link 19 is an Internet link, program guide functionality may be accessed using Hypertext Transfer Protocol. *Id.* at 15:64–66. Remote program guide access device 24 and interactive television program guide equipment 17 also may transfer program guide information as files using either File Transfer Protocol or Trivial File Transfer Protocol running over a Transmission Control Protocol/Internet Protocol stack. *Id.* at 15:66–16:4. The '413 Patent makes clear that “[a]ny suitable file transfer protocol based on any suitable protocol stack may be used.” *Id.* at 16:4–5.

C. Illustrative Claim

Claims 1 and 10 are independent. Independent claim 1 is directed to a system for selecting television programs over a remote access link that includes an Internet communications path for recording, whereas independent 10 is directed to a method for performing the same. Claims 2–9 depend from independent claim 1, and claims 11–18 depend from independent claim 10. Independent claim 1 is illustrative of the challenged claims and is reproduced below:

1. A system for selecting a television program over a remote access link comprising an Internet communications path for recording, the system comprising:

a local interactive television program guide equipment on which a local interactive television program guide is implemented, wherein the local interactive television program guide generates a display of one or more television program listings for display on a display device at a user's home, wherein the local interactive television program guide equipment is located within the user's home and includes user television equipment, wherein a mobile device communicates with the local interactive television program guide equipment, wherein the mobile device, on which a remote access interactive television program guide is implemented, is located outside of the user's home, and wherein the mobile device:

generates a display of the remote access interactive television program guide, the remote access interactive television program guide comprising a plurality of television program listings for display on the mobile device, wherein the display of the remote access interactive television program guide is generated based on a user profile stored at a location remote from the mobile device;

receives a user selection of the television program for recording by the local interactive television program guide, wherein the user selects the television program by selecting a television program listing from the plurality of television program listings displayed, by the remote access interactive television program guide, on the mobile device; and

transmits, to the local interactive television program guide over the Internet communications path, a communication identifying the television program for recording corresponding to the television program listing selected by the user with the remote access interactive television program guide,

wherein the local interactive television program guide receives the communication and, responsive to the communication, records the television program corresponding to the selected television program listing

using the local interactive television program guide equipment.

Ex. 1101, 40:6–48.

D. Instituted Grounds of Unpatentability

We instituted a trial based on the asserted grounds of unpatentability (“grounds”) set forth in the table below. Dec. on Inst. 40; Paper 32.

References	Basis	Challenged Claims
Sato ² and Humpleman ³	§ 103(a)	1, 3–10, and 12–18
Sato, Humpleman, and Lawler ⁴	§ 103(a)	2 and 11
Woo, ⁵ Mizuno, ⁶ and Rzeszewski ⁷	§ 103(a)	1, 3–10, and 12–18
Woo, Mizuno, Rzeszewski, and Lawler	§ 103(a)	2 and 11

II. ANALYSIS

A. Claim Construction

In an *inter partes* review proceeding, claim terms of an unexpired patent are given their broadest reasonable interpretation in light of the

² U.S. Patent No. 6,408,435 B1; issued June 18, 2002 (Ex. 1115, “Sato”).

³ U.S. Patent No. 6,182,094 B1; issued Jan. 30, 2001 (Ex. 1106, “Humpleman”).

⁴ U.S. Patent No. 5,805,763, issued Sept. 8, 1998 (Ex. 1109, “Lawler”).

⁵ U.S. Patent No. 5,485,219, issued Jan. 16, 1996 (Ex. 1116, “Woo”).

⁶ PCT Int’l Pub. No. WO 97/18636, published May 22, 1997 (Ex. 1117, “Mizuno”).

⁷ U.S. Patent No. 5,699,125, issued Dec. 16, 1997 (Ex. 1118, “Rzeszewski”).

specification of the patent in which they appear. 37 C.F.R. § 42.100(b). Under the broadest reasonable interpretation standard, and absent any special definitions, claim terms are generally given their ordinary and customary meaning, as would be understood by one of ordinary skill in the art, in the context of the entire disclosure. *In re Translogic Tech., Inc.*, 504 F.3d 1249, 1257 (Fed. Cir. 2007).

In the Decision on Institution, we determined that the only claim terms requiring construction are “local/remote access interactive television program guides,” and only to the extent necessary to resolve whether the grounds asserted by Comcast properly accounted for both a “local interactive television program guide” and a “remote access interactive television program guide.” Dec. on Inst. 9 (citing *Vivid Techs., Inc. v. Am. Sci. & Eng’g, Inc.*, 200 F.3d 795, 803 (Fed. Cir. 1999) (explaining that only those claim terms that are in controversy need to be construed, and only to the extent necessary to resolve the controversy)). Upon reviewing the parties’ preliminary arguments and evidence, we adopted Comcast’s proposed construction that an “interactive television program guide” is “control software operative at least in part to generate a display of television program listings and allow a user to navigate through the listings, make selections, and control functions of the software.” *Id.* at 13. We further clarified that the claim terms “local interactive television program guide” and “remote access interactive television program guide” are separately identifiable elements, and are not construed properly as reading on the same interactive television program guide. *Id.*

In its Patent Owner Response, Rovi generally agrees with our initial determination that the only claim terms requiring construction are

“local/remote access interactive television program guides.” PO Resp. 8–9. Rovi, however, proposes that the proper constructions for these claim terms are the following: (1) “local interactive television program guide” is a “guide that allows navigation through television program listings and causes display of program information on user television equipment”; and (2) “remote access interactive television program guide” is a “guide allowing navigation through television program listings using a remote access link.” *Id.* at 9. According to Rovi, its proposed constructions for the claim terms “local/remote access interactive television program guides” are consistent with the intrinsic evidence, our preliminary finding that these guides must be distinct guides, and the findings of the ITC in related proceedings. *Id.* at 9–10 (citing Ex. 2101, 193, 198, 409).

Rovi further contends that any difference between our constructions and the ITC’s constructions of the claim terms “local/remote access interactive television program guides” is not relevant to the grounds at issue in this proceeding because, according to Rovi, all of Comcast’s asserted grounds fail under Rovi’s broader constructions “that do[] not unnecessarily restrict the guides to ‘control software’ that ‘controls functions of the software.’” PO Resp. 10–11. Rovi asserts that, because Comcast’s asserted grounds fail under broader constructions for these claim terms, we need not determine whether the asserted prior art satisfies Comcast’s proposed constructions. *Id.* at 11. Rovi then proceeds to explain how our preliminary constructions and the ITC’s constructions are consistent in certain respects because (1) they both require the guides to be interactive (i.e., navigable and

selectable); and (2) they both agree that the claims require two separate guides, as properly construed. *Id.* at 11–13.⁸

In its Reply, Comcast contends that Rovi’s proposed constructions of the claim terms “local/remote access interactive television program guides” improperly seek to limit the broadest reasonable interpretation of the claim term “interactive television program guide” to a single software component that generates listings, thereby excluding other software components that assist in providing guide functionality. Pet. Reply 4 (citing PO Resp. 30–34; Ex. 2011 ¶¶ 134–135, 144–148). According to Comcast, this exclusion finds no basis in the plain language of the claims and the specification of the ’413 Patent. *Id.* at 4–5 (citing Ex. 1152 ¶¶ 10–14).

Comcast also contends that Rovi’s arguments directed to the claim term “interactive television program guide” contradict the construction Rovi offered in the related ITC proceeding. Pet. Reply 5. Comcast argues that Rovi expanded the scope of the claim term “local interactive television program guide” in the related ITC proceeding, to capture all software components related to any local guide functionality, including recording. *Id.* (citing Ex. 2101, 188–199, 222–236; Ex. 1154 ¶¶ 158–160, 169, 170, 371, 376). Comcast argues that Rovi’s expert in the ITC proceeding, Dr. Michael Shamos, who also is Rovi’s expert in this proceeding, provided supporting

⁸ For the first time at the oral hearing, Rovi argued that “remote access interactive television program guide” requires “dedicated code at the remote device.” *See, e.g.*, Tr. 58:3–7, 60:19–61:14, 66:14–21. We agree with Comcast (*id.* at 96:3–10) that this is a new argument that was not presented and developed in Rovi’s briefs and, therefore, we do not consider it. *See* Paper 10, 3 (cautioning Rovi that “any arguments for patentability not raised in the response will be deemed waived”).

testimony that the claim term “local interactive television program guide” could be an “extensive collection of hardware and software.” *Id.* (emphasis omitted) (quoting Ex. 1154 ¶ 169). In this proceeding, however, Comcast argues that Rovi and Dr. Shamos appear to take the erroneous position that the claim term “local interactive television program guide” is a single software application. *Id.* at 5–6 (*compare* PO Resp. 32 and Ex. 2111 ¶ 147, *with* Ex. 1154 ¶¶ 169, 376, 371). According to Comcast, we should hold Rovi to the same broad construction of the claim term “local interactive television program guide” in this proceeding that it wielded to exclude others from practicing in the related ITC proceeding. *Id.* at 6.

As an initial matter, it is not clear to us whether Rovi actually disputes our preliminary construction of the claim term “interactive television program guide.” On the one hand, Rovi asserts that the ITC’s constructions of local interactive television program guide (i.e., a “guide that allows navigation through television program listings and causes display of program information on user television equipment”) and remote access interactive television program guide (i.e., a “guide allowing navigation through television program listings using a remote access link”) are the proper constructions. PO Resp. 9. On the other hand, Rovi argues that both our constructions and the ITC’s constructions “are consistent with respect to the relevant aspects (e.g., navigation and selection)” of a local/remote access interactive television program guide. *Id.* at 9–10. Rovi further contends that “[a]ny differences between the Board’s and the ITC’s constructions *are not relevant* to [Comcast’s] failures of proof regarding the asserted prior art and [g]rounds at issue in the proceeding.” *Id.* at 10–11 (emphasis added); *see also* Ex. 2111 ¶ 25 (Rovi’s declarant, Dr. Shamos, testifies that, “regardless

of which constructions the Board applies, my opinions remain the same. The asserted prior art references here fail to disclose the claim limitations . . . under either construction.”). These arguments make it difficult to ascertain what Rovi actually views as the proper scope and meaning of the claim terms “local/remote access interactive television program guides.” Nevertheless, we are charged in this proceeding with determining the broadest reasonable interpretation of these claim terms.

Beginning with the intrinsic record, neither party argues, nor could we find, an explicit definition for the claim term “interactive television program guide” in the specification of the ’413 Patent. The specification, however, is replete with descriptions of conventional, local, or remote interactive television program guides. For instance, the specification discloses that conventional interactive television program guides display “various groups of television program [guide] listings . . . in predefined or user-defined categories,” and “allow the user to navigate through [the] television program listings” and make a selection “using a remote control.” Ex. 1101, 1:28–33. For a conventional interactive television program guide, the user must physically be located in the same room as the set-top box on which the interactive television program guide is implemented to select programs for recording or to perform other guide functions. *Id.* at 1:34–42. In the context of discussing the implementation of a remote access interactive television program guide, the specification discloses that such a guide works in conjunction with a remote device to “provide users with the opportunity to remotely access features of the interactive television program guide on the interactive television program guide equipment and to remotely set program guide settings.” *Id.* at 2:64–3:4. The specification goes on to disclose that

“[a]ny suitable interactive television program guide function or setting may be accessed,” including, but not limited to, “remotely select[ing] programming for recordings” and “remotely set[ting] and navigat[ing] through favorites (e.g., favorite channels, program categories, services, etc.).” *Id.* at 3:5–15.

Although the aforementioned disclosures provide guidance as to the functionality of an “interactive television program guide” (i.e., navigable, selectable, and capable of controlling certain functions or settings), neither party directs us to, nor can we find, a disclosure in the specification that specifically identifies what element or elements constitute a “guide.” Given the lack of disclosure in this regard, we decline to limit the “guide” to a single software application. Rather, these disclosures support Comcast’s proposed construction that an “interactive television program guide” is “control software operative at least in part to generate a display of television program listings and allow a user to navigate through the listings, make selections, and control functions of the software.”

We further clarify that the plain language of independent claims 1 and 10 indicates that the claim terms “local interactive television program guide” and “remote access interactive television program guide” are separately identifiable elements. *See Becton, Dickinson & Co. v. Tyco Healthcare Grp., LP*, 616 F.3d 1249, 1254 (Fed. Cir. 2010) (“Where a claim lists elements separately, ‘the clear implication of the claim language’ is that those elements are ‘distinct component[s]’ of the patented invention.” (alteration in original) (quoting *Gaus v. Conair Corp.*, 363 F.3d 1284, 1288 (Fed. Cir. 2004))). Our determination in this regard is supported by the specification, which includes various embodiments that treat these claim

terms as separately identifiable elements capable of communicating with each other. *See, e.g.*, Ex. 1101, 15:20–23 (“In still another suitable approach, the [local interactive television program guide and remote access interactive television program guide] may be different guides that communicate in a manner or manners discussed . . . herein.”), 23:4–7 (“The remote access [interactive television] program guide may . . . send audio, graphical, and text messages to the local interactive [television] program guide for playing or display by user television equipment 22.”). The specification also explains that the “local interactive television program guide” and “remote access interactive television program guide” may be the same guide, in which case they are separately identifiable elements in that each guide is compiled to run on a different platform. *See id.* at 15:15–18 (“The remote access and local guide may, for example, be the same guide but compiled to run on two different platforms and to communicate in a manner or manners discussed herein.”).

We decline to adopt Rovi’s proposed constructions of the claim terms “local/remote access interactive television program guides” for two reasons. First, we are unable to determine how Rovi’s proposed constructions add any clarity to the scope and meaning of an “interactive television program guide.” That is, we view each of Rovi’s proposed constructions as circular and unhelpful because they define each of the guides as a “*guide* [that allows/allowing] navigation through television program listings.” PO Resp. 9 (emphasis added). Rovi, however, does not actually identify what element or elements specifically constitute the “guide.”

Second, Rovi states that its proposed constructions indicate “where the specific guide resides (i.e., on ‘user television equipment’ or over ‘a

remote access link’),” but readily admits that “these additions merely restate the language of the broader claim limitation[s].” PO Resp. 13–14 (emphasis omitted) (citing Ex. 2101, 193, 198, 409). It is well settled that the Federal Circuit disfavors any claim interpretation that renders a claim term or phrase superfluous. *See Apple, Inc. v. Ameranth, Inc.*, 842 F.3d 1229, 1237 (Fed. Cir. 2016) (“The Board was correct to not include in its construction of ‘menu’ features of menus that are expressly recited in the claims. . . . Construing a claim term to include features of that term already recited in the claims would make those expressly recited features redundant.”). If we were to adopt the language in Rovi’s proposed constructions pertaining to where each guide resides, it would render superfluous the language that is already explicitly recited in independent claim 1, and similarly recited in independent claim 10—namely, “over a remote access link” and “a local interactive television program guide equipment on which a local interactive television program guide is implemented, . . . wherein the local interactive television program guide equipment is located within the user’s home and includes user television equipment.”⁹

Turning now to the extrinsic evidence, in Dr. Tjaden’s Declaration accompanying the Petition, he testifies that “the local [interactive television program] guide may be implemented at least in part on a server or other

⁹ During oral argument, in response to a question regarding the ITC’s construction of the “local interactive television program guide” being on user television equipment and its construction that the “remote access television program guide” uses a remote access link, counsel for Rovi stated that “I don’t think where [the guides are] implemented is meaningful because that’s recited in the claim separately.” Tr. 66:22–67:24.

device outside the user's home.” Ex. 1102 ¶ 36. To support this testimony, he directs us to Rovi's interpretation of the claim term “local interactive television program guide” in the related ITC proceeding. *Id.* (citing Ex. 1145, 56; Ex. 1146, 43). In Dr. Tjaden's Declaration accompanying the Reply, he elaborates further on his initial position by testifying that “a [person of ordinary skill in the art] looking at the '413 Patent would have understood that many different arrangements of the software and hardware components comprising an interactive television program guide are possible and acceptable in [the] prior art used to show obviousness.” Ex. 1152 ¶ 11. To support this testimony, he directs us to the different arrangements of software and hardware in the '413 Patent. *Id.* ¶¶ 16–18 (citing Ex. 1101, 7:15–19, 33–35, 40–47, 9:36–44, 10:15–16, 29–34, 41–48, Figs. 1, 2a–2d).

Comcast also directs us to Dr. Shamos's Declaration in the ITC proceeding as further evidence as to what element or elements constitute a “guide.” Although we recognize that the broadest reasonable interpretation standard governs in this proceeding, whereas the district court claim construction standard governs in an ITC proceeding, Dr. Shamos's testimony in the ITC proceeding is relevant here because it sheds some light on what element or elements he believes constitute a “guide.” In the ITC proceeding, Dr. Shamos testified that the claim term “local interactive television program guide” could be an “extensive collection of hardware and software.” Ex. 1154 ¶ 169. He also testified “that the ‘local [interactive television program] guide’ [should not be construed as] a single software application that must reside on a device in the user's home,” and “[n]othing in the claims exclude a ‘recording application’ from being part of the local [interactive television program] guide.” *Id.* ¶ 371. Dr. Shamos's testimony

in the ITC proceeding is consistent with Dr. Tjaden's testimony in this proceeding because, like Dr. Tjaden, Dr. Shamos does not limit a "guide" to a single software application, but rather contemplates that the "guide" may constitute different arrangements of software and hardware.

We note that the aforementioned testimony from Dr. Tjaden and Dr. Shamos suggests that the "guide" may include both software and hardware. Rovi likewise argues that its proposed construction is broader than Comcast's because it "does not unnecessarily restrict the guides to 'control software.'" PO Resp. 11. We do not find support in the intrinsic record that the "guide" may include hardware. Rather, the '413 Patent separately refers to the interactive television program guide and the hardware on which it is implemented. *See, e.g.*, Ex. 1101, 1:34–35 ("Interactive television program guides are typically implemented on set-top boxes . . ."). The aforementioned testimony, however, is consistent with our conclusion that the "guide" may constitute more than just a single software application.

In summary, upon weighing all the evidence bearing on the construction of the claim term "interactive television program guide," we maintain that the broadest reasonable interpretation of this claim term is "control software operative at least in part to generate a display of television program listings and allow a user to navigate through the listings, make selections, and control functions of the software." We also maintain that the claim terms "local interactive television program guide" and "remote access interactive television program guide" are separately identifiable elements, and are not construed properly as reading on the same interactive television program guide.

B. Obviousness Over the Combined Teachings of Sato and Humpleman

Comcast contends that claims 1, 3–10, and 12–18 of the '413 Patent are unpatentable under § 103(a) over the combined teachings of Sato and Humpleman. Pet. 20–41. Comcast explains how this proffered combination teaches or suggests the subject matter of each challenged claim, and provides reasoning as to why one of ordinary skill in the art would have been prompted to modify or combine the references' respective teachings. *Id.* Comcast also relies upon the Declaration of Dr. Tjaden to support its positions. Ex. 1102 ¶¶ 97–169. In its Patent Owner Response, Rovi presents a number of arguments as to why the combined teachings of Sato and Humpleman do not render the limitations of independent claims 1 and 10 obvious. PO Resp. 20–41. Rovi relies upon the Declaration of Dr. Shamos to support his positions. Ex. 2111 ¶¶ 97–157.

We begin our analysis with the principles of law that generally apply to a ground based on obviousness, followed by an assessment of the level of skill in the art, proceeded by brief overviews of Sato and Humpleman, and then we address the parties' contentions with respect to the claims at issue in this asserted ground.

1. Principles of Law

A claim is unpatentable under § 103(a) if the differences between the claimed subject matter and the prior art are such that the subject matter, as a whole, would have been obvious at the time the invention was made to a person having ordinary skill in the art to which said subject matter pertains. *KSR Int'l Co. v. Teleflex Inc.*, 550 U.S. 398, 406 (2007). The question of obviousness is resolved on the basis of underlying factual determinations, including (1) the scope and content of the prior art; (2) any differences

between the claimed subject matter and the prior art; (3) the level of skill in the art; and (4) when in evidence, objective indicia of non-obviousness (i.e., secondary considerations). *Graham v. John Deere Co.*, 383 U.S. 1, 17–18 (1966). We analyze this asserted ground based on obviousness with the principles identified above in mind.

2. *Level of Skill in the Art*

There is evidence in the record before us that enables us to determine the knowledge level of a person of ordinary skill in the art. Relying on the testimony of its declarant, Dr. Tjaden, Comcast asserts that a person of ordinary skill in the art as of July 17, 1998, which is the earliest priority date on the face of the '413 Patent, would be an individual who possesses the following:

a bachelor's degree in computer science, electrical engineering, computer engineering, or a similar discipline, and two years of experience with interactive program guides, set-top boxes, mobile computer devices, and techniques for delivering content or program guides over communication networks, such as a cable system, a local-area network, and the Internet.

Pet. 13 (quoting Ex. 1102 ¶ 28). Alternatively, once again relying on the testimony of Dr. Tjaden, Comcast asserts that a person of ordinary skill in the art “could have had equivalent experience in industry or research, such as designing, developing, evaluating, testing, or implementing the aforementioned technologies.” *Id.* (quoting Ex. 1102 ¶ 28). Conversely, Rovi's declarant, Dr. Shamos, does not offer an assessment of the level of skill in the art as of July 1998, nor does he explicitly state his intent to adopt Dr. Tjaden's assessment. *See generally* Ex. 2111. Because Dr. Shamos's testimony does not address this matter, we adopt Dr. Tjaden's assessment

because it is consistent with the '413 Patent and the asserted prior art, and apply it to our obviousness evaluation below.

3. Sato Overview

Sato generally relates to a remote controller suitable for use in operating audio/visual devices and, in particular, one that is suitable for use in a system for transmitting broadcast program reservation tables through a computer network. Ex. 1115, 1:7–12. Figure 1, reproduced below, illustrates a block diagram of the network system used in Sato. *Id.* at 2:61–62, 3:49–51.

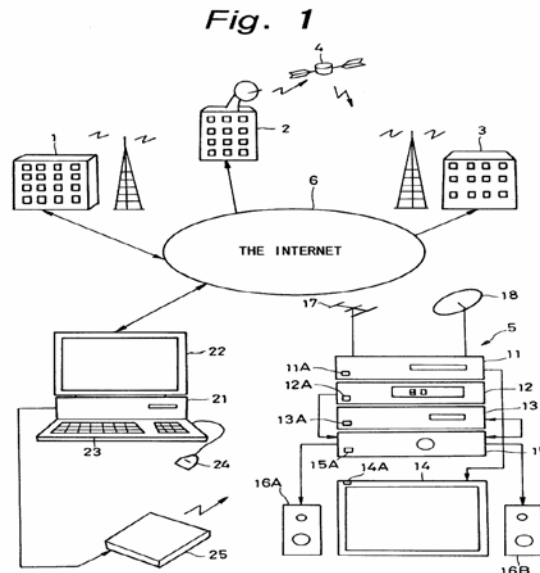

The network system illustrated in Figure 1 reproduced above includes surface wave television (“TV”) broadcasting station 1, satellite TV broadcasting station 2, and frequency modulation (“FM”) radio broadcasting station 3 that broadcast TV programs and/or FM radio programs to audio/visual equipment 5. *Id.* at 3:51–4:1. Audio/video equipment 5 includes, among other things, video tape recorder/player (“VTR”) 11 and TV receiver 14, each of which is capable of being controlled remotely by

infrared signals. *Id.* at 4:1–9. The network system further includes personal computer 21 connected to Internet 6. *Id.* at 4:46–47. Personal computer 21 sends commands to interface box 25, which, in turn, uses infrared signals to communicate desired modes of operation to VTR 11 and TV receiver 14. *Id.* at 4:52–59.

Figure 17, reproduced below, illustrates one embodiment in accordance with the present invention. Ex. 1115, 3:44–45, 9:29–30.

Fig. 17

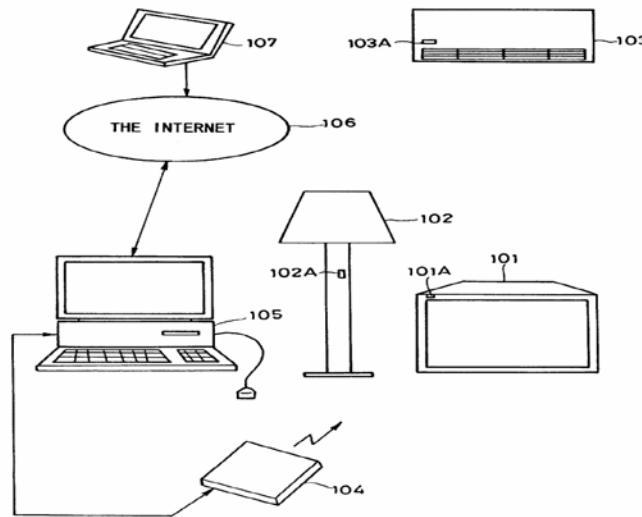

The embodiment illustrated in Figure 17 reproduced above includes TV receiver 101 that is capable of being set to a desired mode of operation using infrared signals from interface box 104 connected to personal computer 105. *Id.* at 9:30–36. This embodiment further includes external portable computer 107, which connects to personal computer 105 through Internet 106 to control TV receiver 101. *Id.* at 9:51–54. For instance, external portable computer 107 generates hypertext commands for setting TV receiver 101 to a desired mode operation. *Id.* at 9:56–59. The hypertext commands are sent from external portable computer 107 to personal

computer 105 through Internet 106. *Id.* at 9:56–61. When interface box 104 receives the hypertext commands from personal computer 105, it issues an infrared signal corresponding to the command contained in the hypertext and, subsequently, sets TV receiver 101 to the desired mode of operation. *Id.* at 9:61–65.

4. *Humpleman Overview*

Humpleman generally relates to the field of networks and, in particular, to home networks that have multimedia devices connected thereto. Ex. 1106, 1:16–18. One objective of Humpleman’s invention is to provide a method for controlling a plurality of devices connected to a home network, where at least one of these devices is a multimedia device, and for generating a program guide from the information provided by the multimedia device on a second device connected to the home network. *Id.* at 2:23–28. According to Humpleman, a user may customize the programming information that is displayed by the program guide. *Id.* at 22:41–43. For instance, if a user prefers not to display the schedule for a particular channel because it contains inappropriate content, the user may request that the channel be removed from the program guide. *Id.* at 22:43–46.

5. *Claims 1 and 10*¹⁰

In its Petition, Comcast contends that Sato’s program guide system accounts for most of the limitations recited in independent claims 1 and 10, except “user profiles” used to generate the “remote access interactive

¹⁰ Comcast contends that independent claims 1 and 10 stand or fall together, along with their dependent claims. Pet. 9–10. Rovi does not dispute Comcast’s assertion in this regard. *Accord* PO Resp. 20–41 (treating independent claims 1 and 10 as standing or falling together).

television program guide.” Pet. 20–24 (citing Ex. 1115, 4:41–59, 5:18–25, 45–54, 9:8–17, 51–65, Figs. 1, 2, 17; Ex. 1102 ¶¶ 97–100); *see also id.* at 27–35 (arguing the same). Comcast turns to Humpleman’s generation of local customized program guides to teach this particular limitation. *Id.* at 24–25 (citing Ex. 1106, 22:30–46; Ex. 1102 ¶ 102); *see also id.* at 31–32 (arguing the same).

For added clarity, we identify the arguments presented by Comcast for all the limitations of independent claim 1. We note that there is no dispute between the parties as to whether the limitations of independent claim 10 are essentially the same as the limitations of independent claim 1. *Compare* Pet. 9–10, 26–35, *with* PO Resp. 20–41. Beginning with the preamble of independent claim 1, Comcast contends that Sato teaches “[a] system for selecting a television program over a remote access link comprising an Internet communications path for recording” because Sato discloses that external portable computer 107 allows a remote user to communicate with personal computer 105 over Internet 106 to control devices within the user’s home. Pet. 27 (citing Ex. 1115, 9:51–65). According to Comcast, Sato’s methods of controlling TV receiver 101 and VTR 11 involve the use of program guide webpages to schedule recordings. *Id.* (citing Ex. 1115, 5:18–25, 5:45–54, Fig. 2; Ex. 1102 ¶¶ 112–114). Comcast argues that, because Sato’s external portable computer 107 also is described as being capable of controlling these same home electronic devices, a person of ordinary skill in the art would have understood that external portable computer 107 presents a program guide that allows the remote user to select a program for recording, as this is how Sato’s program guide system receives selections of programs. *Id.* at 27–28.

Comcast contends that Sato teaches “local interactive television program guide equipment on which a local interactive television program guide is implemented,” as recited in independent claim 1, because Sato discloses that a family may connect its home personal computer to the Internet to access HTML program guides provided by the TV stations. Pet. 28 (citing Ex. 1115, 4:46–54, 9:29–37, Fig. 17; Ex. 1102 ¶¶ 117–118). Comcast argues that Sato’s browser, when presenting the program guide web page, constitutes the claimed “interactive television program guide” because it is control software that is operative at least in part to generate a display of television program listings and allow a user to navigate through the listings, make selections, and control functions of the software (e.g., schedule a recording on local equipment). *Id.* (citing Ex. 1115, 5:8–25).

Comcast contends that Sato teaches “wherein the local interactive television program guide equipment is located within the user’s home and includes user television equipment,” as recited in independent claim 1, because TV receiver 101 and VTR 11 are components of an audio/visual system located in a user’s home. Pet. 29 (citing Ex. 1115, 4:1–9, 4:46–59, 4:60–5:2, Fig. 5; Ex. 1102 ¶¶ 119–120). Comcast argues that Sato teaches wherein “the local interactive television program guide generates a display of one or more television program listings for display on a display device at a user’s home,” as recited in independent claim 1, because users access the program guide webpage using their local personal computer (i.e., personal computer 105), and a browser that runs on the local personal computer generates a program guide display, such as one illustrated in Sato’s Figure 2. *Id.* at 29 (citing Ex. 1115, 4:46–59, Figs. 2, 5; Ex. 1102 ¶ 121).

Comcast contends that Sato teaches “wherein the mobile device, on which a remote access interactive television program guide is implemented, is located outside of the user’s home,” as recited in independent claim 1, because external portable computer 107 is described as being capable of controlling the same home electronic devices as personal computer 105. Pet. 29 (citing Ex. 1115, 9:51–65, Fig. 17; Ex. 1102 ¶¶ 122–128). According to Comcast, a person of ordinary skill in the art would have understood that Sato’s external portable computer 107 presents a program guide display that allows the remote user to select a program for recording because this is how Sato’s program guide system receives program selections. *Id.* at 29–30 (citing Ex. 1102 ¶¶ 123–125). Comcast also argues that, to the extent Sato’s personal computer 105 (Figure 17) and personal computer 21 (Figure 1) are not described as the same element, it would have been obvious to a person of ordinary skill in the art to allow external portable computer 107 to control personal computer 21 because external portable computer 107 is described as capable of controlling any electronic device in the user’s home. *Id.* at 30 (citing Ex. 1115, 9:51–65; Ex. 1102 ¶ 127). Comcast further argues that Sato teaches “wherein a mobile device communicates with the local interactive television program guide equipment,” as recited in independent claim 1, because external portable computer 107 is a portable, computer-based device (i.e., mobile device). *Id.* at 29 (citing Ex. 1102 ¶ 124).

Comcast contends that Sato’s remote guide “generates a display of the remote access interactive television program guide, the remote access interactive television program guide comprising a plurality of television program listings for display on the mobile device,” as recited in independent claim 1, because Sato discloses methods for certain home electronic devices

(e.g., TV receiver 101 or VTR 11) that involve using program guide webpages to schedule recordings. Pet. 30 (citing Ex. 1115, 5:45–54, Fig. 2). Comcast argues that a person of ordinary skill in the art would have understood that Sato’s external portable computer 107 presents a program guide webpage to a remote user, which, in turn, allows the remote user to select a program for recording, because this is how Sato’s program guide system receives selections for programs. *Id.* at 30–31 (citing Ex. 1115, 5:3–7, 5:18–25, 5:45–54; Ex. 1102 ¶¶ 130, 131). Comcast further argues that Sato makes clear that its methods use “hypertexts” rendered for display by a browser on an accessing computer, and this display includes a plurality of program listings from which a remote user may select a program for recording. *Id.* at 31 (citing Ex. 1115, Fig. 2).

Comcast also contends that, to the extent Sato does not teach “wherein the display of the remote access interactive television program guide is generated based on a user profile stored at a location remote from the mobile device,” as recited in independent claim 1, it would have been obvious to one of ordinary skill in the art to generate customized program guides, as taught by Humpleman, for display at Sato’s external portable computer 107. Pet. 31 (citing Ex. 1102 ¶¶ 135–139). To support this argument, Comcast directs us to various teachings in Humpleman that pertain to generating local customized guides that are capable of being displayed on any browser-equipped device, including a remote personal computer. *Id.* (citing Ex. 1106, 2:31–39, 7:25–35, 20:47–51, 20:58–21:3, 22:30–59). Comcast argues that it would have been obvious to a person of ordinary skill in the art to improve Sato’s web-based program guides with Humpleman’s generation of local customized guides for display by a remote device to provide the user

operating Sato's external portable computer 107 with better access to the content he/she desires. *Id.* at 32 (citing Ex. 1102 ¶¶ 131–139, 142–145).

Comcast contends that Sato's remote guide "receives a user selection of the television program for recording by the local interactive television program guide, wherein the user selects the television program by selecting a television program listing from the plurality of television program listings displayed, by the remote access interactive television program guide, on the mobile device," as recited in independent claim 1 because Sato discloses that a user may click on the title of a desired program displayed in the program guide webpage, thereby causing Sato's program guide system to send a record command to local hardware. Pet. 33–34 (citing Ex. 1115, 5:8–17, 5:18–25, 9:8–17, 9:56–65; Ex. 1102 ¶¶ 147, 148). Comcast argues that, although Sato's program guide is discussed with respect to local personal computers 21 and 105, Sato's external portable computer 107 also is capable of controlling any home electronic device, which one of ordinary skill in the art would have understood to include personal TV receiver 101 or VTR 11 illustrated in Figure 1. *Id.* at 34 (citing Ex. 1115, 5:8–17, 5:45–54, Fig. 2; Ex. 1102 ¶ 147).

Comcast contends that Sato's remote guide "transmits, to the local interactive television program guide over the Internet communications path, a communication identifying the television program for recording corresponding to the television program listing selected by the user with the remote access interactive television program guide," as recited in independent claim 1, because, when the user selects an operation (e.g., a program to be recorded), Sato's external portal computer 107 sends a hypertext command to personal computer 105. Pet. 34 (citing Ex. 1115,

6:10–17, 9:56–65; Ex. 1102 ¶¶ 149–151). Comcast argues that, in the case of a scheduled recording, this command includes a representation of a “G code” that is associated with the selected program. *Id.* (citing Ex. 1115, 6:10–17).

Lastly, Comcast contends that Sato teaches “wherein the local interactive television program guide receives the communication and, responsive to the communication, records the television program corresponding to the selected television program listing using the local interactive television program guide equipment,” as recited in independent claim 1, because control software on personal computer 105, which also includes a browser, receives the hypertext command from external portal computer 107 and issues appropriate commands to local hardware. Pet. 35 (citing Ex. 1115, 5:18–25, 9:56–65; Ex. 1102 ¶¶ 152–154). In the case of a recording command, Comcast argues that interface box 25 outputs an infrared signal instructing VTR 11 to record the program at the indicated time. *Id.* at 35 (citing Ex. 1115, 5:18–25); *see also id.* at 9:29–65 (disclosing the same communication process with respect to Figure 17—namely, interface box 104 outputs an infrared signal that sets TV receiver 101 to a desired mode of operation).

Turning to the rationale to combine, Comcast contends that it would have been obvious to one of ordinary skill in the art to incorporate Humpleman’s generation of local customized program guides for display by a remote device into Sato’s program guide system for at least the following three reasons: (1) it would have been nothing more than using known techniques (i.e., Humpleman’s remote display of local customized program guide webpages) to improve a similar device (i.e., Sato’s program guide

system) in the same way; (2) it would have been a simple substitution of Humpleman's generation of local customized program guides for Sato's webpages to produce the predictable result of preventing the display of disfavored channels or content; and (3) using Humpleman's generation of local customized program guides to improve Sato's program guide system—specifically, its webpages—would provide a complete picture of the content available on the user's local television receiver. *Id.* at 24–26 (citing Ex. 1106, 2:23–28, 22:30–46, 22:60–65; Ex. 1115, 4:60–5:2, 9:51–65; Ex. 1102 ¶¶ 102–108); *see also id.* at 32–33 (arguing the same).

In its Patent Owner Response, Rovi presents a number of arguments that can be grouped as follows: (1) whether Comcast has demonstrated that Sato and Humpleman, either alone or in combination, account for all the limitations of independent claims 1 and 10; and (2) whether Comcast has demonstrated that a person of ordinary skill in the art would have had sufficient reasons to combine the teachings of Sato and Humpleman. PO Resp. 20–41. We address these groupings of arguments in turn.

a. Limitations

i. Two Interactive Television Program Guides

Rovi contends that each independent claim requires two interactive television program guides—namely, “a local interactive television program guide” and “a remote access interactive television program guide.” *See* PO Resp. 20–22. Rovi argues that Sato does not teach two interactive television program guides because it is directed to a rudimentary system for controlling home peripherals through a network using infrared signals. *Id.* at 22–23. In particular, Rovi argues that Comcast improperly relies on the embodiment illustrated in Sato's Figure 17 to teach two interactive television program

guides because there is no disclosure of an interactive television program guide in association with this figure, let alone a disclosure of both a local interactive television program guide and a remote access interactive television program guide. *Id.* at 23 (citing Ex. 1115, 9:51–55, Fig. 17; Ex. 2111 ¶¶ 131–134).

Next, Rovi contends that, although Sato discloses passing hypertext commands for devices such as TV receiver 101, illuminator 102, or air conditioner 103 from external portable computer 107 to personal computer 105, Sato is silent with respect to what information is displayed on external portable computer 107, how the display is generated, and whether a user is able to schedule a recording. PO Resp. 24 (citing Ex. 1115, 9:56–65). Indeed, Rovi asserts that a browser program for displaying television listings would not be suitable for devices like Sato’s illuminator 102 or air conditioner 103. *Id.* (citing Ex. 2111 ¶ 132). Rovi further argues that, with respect to the embodiment illustrated in Sato’s Figure 17, Sato does not disclose any source of program guide information for external portable computer 107 that would be necessary for that computer to display television listings, nor does Sato disclose what is displayed on any browser of personal computer 105. *Id.* at 24–25 (citing Ex. 2111 ¶ 133; Ex. 2110, 116:16–117:8).

Rovi then contends that, to overcome the failures of proof with respect to the embodiment illustrated in Sato’s Figure 17, Comcast improperly relies on the teachings of the embodiment illustrated in Sato’s Figure 1 and mistakenly asserts that a guide must exist in the embodiment associated with Figure 17 because “that is how Sato’s system receives selections of programs.” PO Resp. 25 (quoting Pet. 23). Rovi also argues that Comcast

improperly relies on the program listing screen illustrated in Sato's Figure 2 as teaching an interactive television program guide because this figure is not discussed in connection with external portable computer 107 illustrated in Sato's Figure 17, nor is it discussed with respect to any purported remote interactive television program guide. *Id.* (citing Ex. 1102 ¶¶ 112, 119). Indeed, Rovi argues that the program listing screen illustrated in Sato's Figure 2 would not be suitable for controlling illuminator 102 or air conditioner 103 because these devices would not use program listings. *Id.* (citing Ex. 2111 ¶¶ 136–138). Rovi further argues that a person of ordinary skill in the art would not have been motivated to combine the embodiments illustrated in Sato's Figures 1, 2, and 17 because they are different embodiments for different purposes, and the embodiment in Figure 17 is a separate, complete system that would not be understood to work in conjunction with any other embodiments. *Id.* at 26–27 (citing *Jackel Int'l Ltd. v. Mayborn USA, Inc.*, Case IPR2015-00979, slip op. at 4 (PTAB May 20, 2016) (Paper 21); Ex. 1115, 3:44–45, 9:30–31; Ex. 2111 ¶ 137).

Lastly, Rovi contends that modifying the teachings of Sato with those of Humpleman would not produce the claimed two interactive television program guides. PO Resp. 28. Relying on the Humpleman provisional (Ex. 1107), Rovi argues that the DirecTV Satellite System (“DSS”) server observes a request from the DSS's Hypertext Markup Language (“HTML”) page, retrieves the necessary information, and then passes it along to the digital video cassette record's HTML page. *Id.* at 28–29 (citing Ex. 1107, 14; Ex. 2111 ¶¶ 113, 114). Rovi asserts that Humpleman's DSS server is not guide software that is capable of handling recording requests and, therefore, inserting Humpleman's HTML program guides into the

embodiment illustrated in Sato's Figure 17 would not yield the claimed two interactive program guides. *Id.* at 30.

In its Reply, Comcast counters that Rovi's arguments attempt to "erect an artificial wall" between the embodiment illustrated in Sato's Figure 17 and Sato's teachings of program guide webpages. Pet. Reply 8. According to Comcast, a person of ordinary skill in the art would not have read the embodiment illustrated in Sato's Figure 17 in isolation from the rest of the teachings in Sato. *Id.* at 9. Comcast argues that, because Sato explicitly discloses that "TV receiver 101 . . . or any other electronic device can be controlled through the external portable computer 107," a person of ordinary skill in the art would have understood that "any other electronic device" includes VTR 11 illustrated in Sato's Figure 1, and that VTR 11 could be instructed "to record the program at the indicated time" responsive to a remote user selecting a program on external portable computer 107. *Id.* at 9–10 (quoting Ex. 1115, 9:51–55, 5:18–25) (citing Ex. 1152 ¶¶ 9, 20, 27, 28).

Next, Comcast argues that Sato provides extensive disclosures of program guide webpages for scheduling recordings. Pet. Reply 10 (citing Ex. 1115, 5:18–25, 5:45–54, Fig. 2). Comcast then asserts that, based on these disclosures, a person of ordinary skill in the art would have understood that using Sato's personal computer 105 or external portable computer 107 to control VTR 11 for purposes of recording a TV program would have been done using the same program guide webpages in the same way that is taught with respect to Sato's personal computer 21. *Id.* (citing Ex. 1115, 4:60–5:25, Figs. 1, 2, 16; Ex. 1152 ¶¶ 21–23). Comcast argues that Sato's Figures 1 and 17 have a number of common components and the different purpose

for which Sato's Figure 17 refers to is allowing external portable computer 107 to control home electronic devices remotely. *Id.* (citing Ex. 1152 ¶ 27).

Comcast further contends that there is no support for Rovi's assertion that Sato's Figure 17 illustrates an embodiment that would or could not use program guide information. Pet. Reply 10. Indeed, Comcast argues that the similarities between Sato's Figures 1 and 17 "do[] not require a leap of inventiveness" to support its assertion that external portable computer 107 illustrated in Figure 17 is capable of controlling VTR 11 or TV receiver 101 using the same program guide webpages used for controlling VTR 11 and TV receiver 14 illustrated in Figure 1. *Id.* at 10–11 (quoting *Boston Scientific Scimed, Inc. v. Cordis Corp.*, 554 F.3d 982, 991 (Fed Cir. 2009)). Comcast further argues that Rovi's arguments presume that one of ordinary skill in the art lacked any amount of creativity as to what information is capable of being displayed on Sato's external portable computer 107 and essentially denies such a person the ability to consider Sato, as a whole. *Id.* at 11.

Comcast takes issue with Rovi's argument that Sato's program guide webpages would not be suitable for controlling illuminator 102 or air conditioner 103 because these devices would not use program listings. Pet. Reply 12 (citing PO Resp. 24–25, 27). Relying on the supporting testimony of Dr. Tjaden, Comcast asserts that different commands and interfaces would be used for different devices. *Id.* (citing Ex. 1152 ¶ 23). For instance, Comcast argues that Sato discloses controls to maintain "an optimum value of the cooling effect by the air conditioner 103" that would not be suitable for controlling TV receiver 101. *Id.* (quoting Ex. 1115, 9:39–41). Stated differently, Comcast argues that there is no requirement in Sato

that a single universal user interface must be used to control all home electronic devices. *Id.*

Comcast also contends that Rovi's reliance on the discussion of combining two different embodiments in the Board's Decision on Request for Rehearing in *Jackel International Ltd. v. Mayborn USA, Inc.*, Case IPR2015-00979 (PTAB May 20, 2016) (Paper 21) ("*Jackel Int'l*") is misplaced. Pet. Reply 11. Comcast asserts that *Jackel Int'l* is distinguishable from this case because the Petitioner in *Jackel Int'l* argued that combining two different embodiments was obvious merely because "it's the same reference," whereas here Comcast has provided detailed reasoning as to why one of ordinary skill in the art would have been motivated to use Sato's external portable computer 107 illustrated in Figure 17 to control VTR 11 or TV receiver 101 using the same program guide webpages used to control VTR 11 or TV receiver 14 illustrated in Figure 1. *Id.* (quoting *Jackel Int'l*, slip op. at 4) (citing Pet. 20–23).

Lastly, Comcast contends that it only relies on the teachings of Humpleman in connection with the "user profiles" used to generate the "remote access interactive television program guide," as claimed. Pet. Reply 18. Comcast asserts that, even though Humpleman teaches communication between two interactive television program guides, Comcast relies on Sato's teachings on this point. *Id.* (citing Pet. 31–33; Ex. 1152 ¶¶ 31–33).

When evaluating claims for obviousness, it is well settled that "the prior art as a whole must be considered." *In re Hedges*, 783 F.2d 1038, 1041 (Fed. Cir. 1986); *see also In re Merck & Co., Inc.*, 800 F.2d 1091, 1097 (Fed. Cir. 1986) (explaining that a reference "must be read, not in isolation, but for what it fairly teaches in combination with the prior art as a whole").

“It is impermissible within the framework of section 103 to pick and choose [teachings] from any one reference . . . to the exclusion of other parts necessary to the full appreciation of what such reference fairly suggests to one of ordinary skill in the art.” *Hedges*, 783 F.2d at 1041 (quoting *In re Wesslau*, 353 F.2d 238, 241 (CCPA 1965)). In the same vein, “[a] reference must be considered for everything that it teaches by way of technology and is not limited to the particular invention it is describing and attempting to protect.” *EWP Corp. v. Reliance Universal Inc.*, 755 F.2d 898, 907 (Fed. Cir. 1985).

Based on the record developed during trial, we agree with Comcast that Sato renders the claimed “local interactive television program guide” obvious because Sato teaches or fairly suggests that a remote user may access a program guide webpage, such as the one illustrated in Figure 2, using a browser that runs on personal computer 105 illustrated in Figure 17. *See* Pet. 28–30. With reference to Figure 17, Sato discloses that external portable computer 107 sends hypertext commands to personal computer 105 through Internet 106. Ex. 1115, 9:56–61. After personal computer 105 receives these hypertext commands, they are then sent to interface box 104, which, in turn, generates infrared signals responsive to the commands that are used to control a number of home electronic devices (e.g., TV receiver 101, illuminator 102, air conditioner 103, or any other electronic device, such as VTR 11 illustrated in Figure 1). *Id.* at 9:45–55, 9:61–65.

Although the corresponding description of Sato’s Figure 17 is silent with respect to how personal computer 105 receives and displays hypertext commands from external portable computer 107, other disclosures in Sato provide a full appreciation as to how personal computer 105 operates in this

regard. For instance, and as discussed in more detail below, after reading Sato in its entirety, one of ordinary skill in the art would have recognized that there is a corollary between personal computer 21 illustrated in Figure 1 and personal computer 105 illustrated in Figure 17. Sato discloses that personal computer 21 operates browser 41 that, when rendering a webpage that includes a program guide display such as the one illustrated in Figure 2, allows a user to record desired programs. Ex. 1115, 4:60–5:17, 5:45–54, Figs. 2, 5. Using mouse 24, the user may click on the desired program and, in response, interface box 25 sends an infrared signal to VTR 11 to record the selected program. *Id.* at 5:18–25. Given these disclosures regarding personal computer 21 illustrated in Figure 1, we find that one of ordinary skill in the art would have understood that personal computer 105 illustrated in Figure 17 operates a browser to access a program guide webpage, such as the one illustrated in Figure 2, in the same way as personal computer 21 operates a browser to access the same program guide webpage.

Comcast’s declarant, Dr. Tjaden, provides testimony that supports our finding that one of ordinary skill in the art would have understood that Sato’s personal computer 105 operates a browser that, when rendering a webpage that includes a program guide display such as the one illustrated in Figure 2, allows a user to record desired programs. In his Declaration accompanying the Petition, Dr. Tjaden clarifies that “[o]ne of ordinary skill in the art would [have understood] that . . . browser software operates to receive user input and execute instructions included in the HTML code of the [webpage] (such as Sato’s recording links).” Ex. 1102 ¶ 100 (citing Ex. 1115, 9:51–65). In his Reply Declaration, Dr. Tjaden testifies that “a [person of ordinary skill in the art] would have understood that the

computers depicted in [Figure] 17 would be implemented using the same browsers disclosed in [Figures] 1 and 2.” Ex. 1152 ¶ 24. We credit the aforementioned testimony of Dr. Tjaden because it is consistent with reading Sato, as whole, without viewing the corresponding description of Sato’s Figure 17 at the exclusion of other teachings in Sato that provide a full appreciation as to how personal computer 105 uses a browser to receive and display hypertext commands.

Our finding in this regard also comports with our construction of “interactive television program guide.” In our claim construction section above, we determine that the broadest reasonable interpretation of an “interactive television program guide” is “control software operative at least in part to generate a display of television program listings and allow a user to navigate through the listings, make selections, and control functions of the software.” *See supra* Section II.A. When the browser operating on Sato’s personal computer 105 renders a webpage that includes a program guide display and allows a user to select desired programs for recording, we find that it effectively operates as part of an “interactive television program guide” because it displays program listings and allows the user to navigate through the listings, make selections, and control recording functions.

Based on the record developed during trial, we also agree with Comcast that Sato renders the claimed “remote access interactive television program guide” obvious because Sato teaches or fairly suggests that external portable computer 107 uses a browser to present a program guide webpage that allows the remote user to select a program for recording. *See* Pet. 29–30. As we explained above with respect to Sato’s Figure 17, when external portable computer 107 is connected to personal computer 105 through

Internet 106, it is capable of controlling TV receiver 101, illuminator 102, air conditioner 103, and any other electronic device, such as VTR 11 illustrated in Figure 1. Ex. 1115, 9:51–55; *see also id.* at 4:1–5, 5:18–25 (disclosing that audio/visual system 5 that each family owns includes, among other things, VTR 11 that records programs).¹¹

Although Sato discloses that external portable computer 107 sends hypertext commands for controlling these home electronic devices to personal computer 105 (Ex. 1115, 9:59–61), the corresponding description of Sato’s Figure 17 is silent as to what is displayed on external portable computer 107 and how the hypertext commands are sent to personal computer 105. Nonetheless, after reading Sato in its entirety, there are other disclosures in Sato that provide one of ordinary skill in the art with a full appreciation as to how external portable computer 107 operates to perform this function. For instance, Sato suggests that external portable computer 107 uses a browser to send hypertext commands to personal computer 105 because Sato discloses that a hypertext command is a key underlying concept of a webpage displayed by a browser. *See, e.g., id.* at 5:30–31 (disclosing that “the [world wide web] page shown in FIG. 2 contains a description in [the] form of a hypertext as shown in FIG. 3”), Figs. 2, 3 (illustrating web pages with hypertext commands). In addition, apart from

¹¹ Rovi does not argue that Sato’s disclosure of “any other electronic device[s]” (Ex. 1115, 9:53–54) does not include VTR 11 illustrated in Figure 1. Instead, Rovi argues that Sato’s Figure 17 embodiment does not teach any interactive television program guide for controlling such a VTR, and that it would not have been obvious to combine Sato’s Figure 17 embodiment with the separate embodiments of Figures 1 and 2. *See* PO Resp. 22–28.

being described as both external and portable, there is nothing in Sato that suggests that external portable computer 107 is anything other than a general purpose computer that uses a browser to render a webpage in the same way that both personal computer 21 illustrated in Figure 1 and personal computer 105 illustrated in Figure 17 use a browser to render a webpage.

Comcast's declarant, Dr. Tjaden, provides testimony that supports our finding that one of ordinary skill in the art would have understood that Sato's personal computer 107 operates a browser that, when rendering a webpage that includes a program guide display such as the one illustrated in Figure 2, allows a user to record desired programs. In his Declaration accompanying the Petition, Dr. Tjaden testifies that a person of ordinary skill in the art would have understood that:

“external portable computer 107” could and would access the HTML program guide [illustrated in Figure 2] using a browser to implement a similar interactive television program guide as described for the “personal computer 105,” because this is how Sato describes effecting the recording features and both devices are computers described as operating to set the user television equipment to a desired mode of operation.

Ex. 1102 ¶ 125 (citing Ex. 1115, 5:3–7, 9:51–61); *see also* Ex. 1152 ¶ 23 (Dr. Tjaden testifies that “external portable computer 107 could and would display television program listings like those described with respect to [Sato's Figures] 1 and 2 using Sato's WWW [world wide web] client-server teachings.”).

Dr. Tjaden also testifies that, to the extent Sato does not disclose explicitly how external portable computer 107 operates, “a [person of ordinary skill in the art] would be motivated to look elsewhere in the Sato disclosure to determine how to configure the ‘external personal computer

107.” Ex. 1102 ¶ 126. According to Dr. Tjaden, “[w]hen doing so, a [person of ordinary skill in the art] would [have recognized] that both the ‘external personal computer 107’ and the ‘personal computer[s] 21 and 105]’ are similar in that they are personal computers [that] control audio/visual equipment over the Internet via use of WWW pages.” *Id.* We credit the aforementioned testimony of Dr. Tjaden because it is consistent with reading Sato, as whole, without viewing the corresponding description of Sato’s Figure 17 at the exclusion of other teachings in Sato that provide a full appreciation as to how external portable computer 107 uses a browser to display and send hypertext commands.

Similar to our analysis above, our finding in this regard also comports with our construction of “interactive television program guide.” In our claim construction section above, we determine that the broadest reasonable interpretation of an “interactive television program guide” is “control software operative at least in part to generate a display of television program listings and allow a user to navigate through the listings, make selections, and control functions of the software.” *See supra* Section II.A. When the browser operating on Sato’s external portable computer 107 renders a webpage that includes a program guide display and allows a user to select desired programs for recording, as in Sato’s Figure 2, we find that it effectively operates as part of an “interactive television program guide” because it displays program listings and allows the user to navigate through the listings, make selections, and control recording functions. Moreover, Sato’s external portable computer 107 is a different platform than personal computer 105 such that the interactive television program guides that run on

each of these devices are separately identifiable. *See supra* Section II.A (citing Ex. 1101, 15:15–18)

Rovi’s arguments that the program guide display illustrated in Figure 2 of Sato would not be suitable for controlling illuminator 102 or air conditioner 103 because these devices would not use program listings is misplaced. *See* PO Resp. 24. There is no requirement in Sato that a single universal user interface, such as the program guide webpage illustrated in Figure 2, must be used to control all home electronic devices (i.e., TV receiver 101, illuminator 102, air conditioner 103, VTR 11, etc.). Separate commands for controlling Sato’s illuminator 102 and air conditioner 103 are not present in Figure 2 because there is no illuminator or air conditioner being controlled in that embodiment. Comcast’s declarant, Dr. Tjaden, testifies—and we agree—that “[a person of ordinary skill in the art] would . . . have understood that different devices around the home would require different commands and interfaces.” Ex. 1152 ¶ 23 (citing Ex. 1115, 9:39–44, 9:51–65). Based on the teachings of Sato identified above and Dr. Tjaden’s supporting testimony, we find that one of ordinary skill in the art would have appreciated the controls suitable for illuminator 102 and air conditioner 103 differ in certain respects from the controls suitable for TV receiver 101 and VTR 11. Stated differently, one of ordinary skill in the art would have recognized that the program guide webpage is capable of being equipped with the commands that correspond to the actual electronic devices that are being controlled.

We do not agree with Rovi’s argument that a person of ordinary skill in the art would not have been motivated to combine the embodiments illustrated in Sato’s Figures 1, 2, and 17 because they are different

embodiments for different purposes, and the embodiment in Figure 17 is a separate, complete system that would not be understood to work in conjunction with any other embodiments. *See* PO Resp. 26–27. Although Sato discloses that Figure 17 illustrates “an example of a system used for a different purpose” (Ex. 1115, 9:29–30), Sato’s Figures 1 and 17 also share a number of common components (i.e., interface boxes 24 and 104, personal computer 21 and 105, TV receiver 14 and 101, Internet 6 and 106, etc.). Given the similarities between these figures, it is incumbent upon us in an obviousness evaluation to look to the corresponding description of Figure 1 to get a full appreciation as to what that figure fairly suggests to one of ordinary skill in the art with respect to the components it shares with Figure 17. *See In re Burckel*, 592 F.2d 1175, 1179 (CCPA 1979) (“Under 35 U.S.C. § 103, a reference must be considered not only for what it expressly teaches, but also for what it fairly suggests.”).

To the extent Sato’s Figure 17 is directed to a different purpose than Sato’s Figure 1, Comcast’s declarant, Dr. Tjaden, explains that “a [person of ordinary skill in the art] would have understood that the ‘different purpose’ of [Figure] 17 is to control [home electronic] devices remotely, including devices for recording television programs.” Ex. 1152 ¶ 27 (citing Ex. 1115, 9:51–65). Notwithstanding this difference (or any other differences including the additional electronic devices being controlled), the embodiment of Sato’s Figure 17 describes the same functionality of the embodiment of Sato’s Figure 1 with respect to controlling a TV receiver and other electronic devices using a computer and infrared signals. *Compare* Ex. 1115, 4:41–59, *with id.* at 9:51–65. One of ordinary skill in the art would have known to combine the embodiment of Sato’s Figure 17 with elements

of Sato's Figures 1 and 2 to achieve the same functions described in relation to Figure 17. *See Tyco Healthcare Grp. LP v. Ethicon Endo-Surgery, Inc.*, 774 F.3d 968, 978 (Fed. Cir. 2014) (“[O]ne of ordinary skill is also one of ‘ordinary creativity’ that knows how to combine familiar prior art elements to achieve the same functions.”); *Boston Sci. Scimed*, 554 F.3d at 991 (“Combining two embodiments disclosed adjacent to each other in a prior art patent does not require a leap of inventiveness.”). Accordingly, we agree with Dr. Tjaden that a person of ordinary skill in the art would have looked to Sato's Figures 1 and 2 for a teaching as to how the system illustrated in Sato's Figure 17 controls electronic devices, such as a VTR for scheduling program recordings. Ex. 1152 ¶¶ 27, 28.

We agree with Comcast that Rovi's reliance on the discussion of combining two different embodiments in the Board's Decision on Request for Rehearing in *Jackel Int'l* is misplaced. *See* Pet. Reply 11. As an initial matter, the Board's Decision on Request for Rehearing in *Jackel Int'l* is not precedential and is not binding on this panel. Nevertheless, we have reviewed this Decision on Request for Rehearing. Our review of this Decision, however, reveals that it is distinguishable from arguments and evidence presented by Comcast in this case.

In *Jackel Int'l*, the Board explained that the petitioners challenged claims 6 and 13 of U.S. Patent No. 8,695,841 B2 (“the '841 patent”) as unpatentable § 103(a) over the combined teachings of Mutti, Kano, and Suffa. *Jackel Int'l*, slip op. at 4. The Board then explained that the petitioners relied on Mutti's Figure 6 to account for the limitations of independent claim 1 of the '841 patent, and then relied on Mutti's Figures 1–5 to account for the limitations of claim 6 of the '841 patent, which depends

from independent claim 1. *Id.* The Board explained that the petitioners' rationale for doing so was that "the 'motivation to combine the teachings of Mutti in one embodiment with the teachings of Mutti in another embodiment is entirely obvious—it's the same reference.'" *Id.* The Board, however, explained that this rationale was not presented and developed in the petition itself, but rather was presented in the first instance in the request for rehearing. *Id.* slip op. at 5. The Board further found that there was no motivation to combine the embodiments where the modification involved adding a feature from Figure 1 to perform a function that was already being performed in Figure 6. *See id.*

In contrast, Comcast does not advocate that the motivation to combine the teachings of the embodiment illustrated in Sato's Figure 17 with the teachings of the embodiments illustrated in Sato's Figures 1 and 2 is obvious simply because these figures are in the same reference. Unlike in *Jackel Int'l*, Comcast sets forth a motivation to combine the embodiments in Sato's Figures 1 and 17 in the Petition itself, which has a rational basis. In particular, Comcast explains that the combination results in the remote guide having a useful user interface allowing users to select programs, as is done on the local device. Pet. 23. Moreover, as we explained above, the evidence of record provides a number of reasons as to why one of ordinary skill in the art would have read Sato, as a whole, to get a full appreciation of the embodiment illustrated in Sato's Figure 17, including, but not limited to: (1) Sato's Figure 1 and 17 share common components; (2) the supporting testimony of Dr. Tjaden makes clear that certain aspects of Sato's Figure 17, specifically how personal computer 105 and external portable computer 107 operate browsers that render webpages including hypertext commands for

controlling home electronic devices, are described in more detail with respect to Sato's Figures 1 and 2; and (3) one of ordinary skill in the art would have known to combine the embodiment of Sato's Figure 17 with certain elements of Figures 1 and 2 to achieve the same functions described in relation to Figure 17.

Lastly, contrary to Rovi's argument, Comcast does not seek to modify the teachings of Sato with those of Humpleman to account for the claimed two interactive television program guides. *See* PO Resp. 28–30. As we explain above, Comcast's asserted ground based on the combined teachings of Sato and Humpleman relies on both Sato's personal computer 105 and external portable computer 107 operating browsers, each of which renders webpages that include the program guide display such as the one illustrated in Figure 2, to account for the "local/remote access interactive television program guides," as claimed. *See* Pet. 23, 28–30, 35. Comcast turns to Humpleman to teach the "user profiles" used to generate the "remote access interactive television program guide," as claimed. *See id.* at 24–26, 30–33.

ii. Guide-to-Guide Communication

Rovi contends that each independent claim requires communication between two interactive television program guides. *See* PO Resp. 20–22, 30. Rovi argues that Comcast does not take the position that the browsers operating on Sato's external portable computer 107 and personal computer 105 communicate with each other, but rather Comcast only argues that these two computers can communicate with each other. *Id.* at 30–31 (citing Pet. 33–34). Relying on the testimony of its declarant, Dr. Shamos, Rovi argues that any browsers in Sato do not communicate with each other as the claims require. *Id.* at 31 (citing Ex. 2111 ¶ 134). At most, Rovi argues that

Comcast identifies communications between the alleged browser operating on Sato's external portable computer 107 and hardware (i.e., personal computer 105 and interface box 104), which improperly conflates hardware and software, and does not comport with our preliminary construction of "guide" that requires "control software"—not hardware. *Id.*

Rovi further contends that Comcast does not identify any evidence that Sato's external portable computer 107 sends hypertext commands to the browser operating on personal computer 105. PO Resp. 31. According to Rovi, this hypertext command passes through personal computer 105 to interface box 104, but there is no disclosure that any browser operating on personal computer 105 actually receives the hypertext command. *Id.* (citing Ex. 2111 ¶¶ 146, 147). Rovi argues that Comcast's declarant, Dr. Tjaden, does not provide any additional support for this position because he fails to identify any disclosure in Sato that the browsers operating on external portable computer 107 and personal computer 105 communicate with each other. *Id.* Indeed, Rovi asserts that Dr. Tjaden conceded at his deposition that the hypertext command is "probably not" sent to any browser on Sato's personal computer 105, and that Sato does not disclose what software on personal computer 105 handles the hypertext command. *Id.* at 31–32 (citing Ex. 2110, 116:17–22); *see also id.* at 32 (arguing the same).

Next, Rovi contends that Sato does not teach that browsers operating on external portable computer 107 and personal computer 105 communicate with each other because Sato discloses the hypertext commands are sent to the home electronic devices from external portable computer 107 to interface box 104 through personal computer 105. PO Resp. 32. To support this argument, Rovi argues that Sato explicitly discloses, "[i]n receipt of the

hypertext, the interface box 104 issues an infrared signal corresponding to the command in the hypertext.” *Id.* (quoting Ex. 1115, 9:61–63).

Rovi then contends that Sato does not disclose the browser operating on personal computer 105 receives hypertext commands, or that the browser operating on external portable computer 107 transmits hypertext commands to a browser on personal computer 105. PO Resp. 32–33. According to Rovi, Sato’s alleged browsers cannot communicate with each other because there is no corresponding browser communications protocol. *Id.* at 33 (citing Ex. 2111 ¶¶ 147, 148). Instead, Rovi argues that Sato’s personal computer 105 would act like a server that receives hypertext commands and passes those commands to interface box 104, without necessarily invoking any browser. *Id.* (citing Ex. 1115, 6:28–39).

Lastly, Rovi contends Comcast improperly relies on inherency arguments to demonstrate that Sato discloses guide-to-guide communication. PO Resp. 33. Relying on its declarant, Dr. Shamos, Rovi argues that not only does Sato’s browsers lack a communication protocol for communicating with each other, but Sato’s external portable computer 107 sends hypertext commands to personal computer 105—not any browser operating on that computer. *Id.* at 34 (citing Ex. 2111 ¶ 148). Rovi asserts that Comcast fails to show that Sato’s Figure 17 requires a browser operating on personal computer 105 that receives hypertext commands, but rather Sato only discloses that personal computer 105 passes those commands to interface box 104. *Id.* (citing Ex. 1115, 9:44–65).

In its Reply, Comcast counters that Rovi mischaracterizes its position as relying on just the browser operating on personal computer 105 to teach the claimed “local interactive television program guide” Pet. Reply 13.

Instead, Comcast argues that it relies on the control software on Sato's personal computer 105—not just the browser—to account for this limitation. *Id.* (citing Pet. 34–35; Dec. on Inst. 21). Relying on the testimony of its declarant, Dr. Tjaden, Comcast asserts that a person of ordinary skill in the art would have understood that Sato's external portable computer 107 sends a hypertext command to communications software on personal computer 105. *Id.* (citing Ex. 1152 ¶¶ 29, 30, 36, 37). Comcast argues that Rovi's argument that the browsers on these two computers do not communicate directly with each other overlooks that, under the broadest reasonable interpretation standard, the communications software on Sato's personal computer 105 is part of the claimed “local interactive television program guide.” *Id.* (citing Ex. 1152 ¶¶ 34, 25, 54, 55).

Comcast disagrees with Rovi's argument that the communications from Sato's external portable computer 107 are handled solely by hardware of personal computer 105 or interface box 104 because this argument ignores the actual skill in the relevant art. Pet. Reply 13. Relying on the testimony of Dr. Tjaden, Comcast argues that a person of ordinary skill in the art would have understood that control software of Sato's personal computer 105 would process the received hypertext commands and issue appropriate commands to local devices. *Id.* at 14 (citing Ex. 1102 ¶¶ 152, 153; Ex. 1152 ¶¶ 36–40; Ex. 1115, 9:56–65, Fig. 17). Comcast clarifies that it never argued in the Petition that Sato's browsers communicate directly with each other. *Id.* at 15. To demonstrate that it did not present this line of argument, Comcast directs us to the supporting testimony of Dr. Tjaden in his Declaration accompanying the Petition. *Id.* (quoting Ex. 1102 ¶ 153). Comcast reiterates that control software of Sato's personal computer 105 is

considered properly to be part of the claimed “local interactive television program guide.” *Id.* (citing Ex. 1152 ¶¶ 34, 35, 49–51).

Comcast also disagrees with Rovi’s characterization of Sato’s personal computer 105 as merely a conduit that receives hypertext commands for external portable computer 107 and passes those commands to interface box 104. Pet. Reply 15 (citing PO Resp. 32–33; Ex. 2111 ¶ 147). Comcast argues that Rovi fails to appreciate that the control software on Sato’s personal computer 105 would need to receive the hypertext commands for external portable computer 107 and generate an appropriate command to send to interface box 104. *Id.* (citing Ex. 1152 ¶ 39). Comcast further argues that the hypertext commands themselves are not suitable for direct conversion to infrared signals, and that some processing is required by Sato’s personal computer 105 in receipt of those commands. *Id.* Consequently, Comcast asserts that control software on Sato’s personal computer 105 receives and processes the hypertext commands, and controls interface box 104 to generate a suitable infrared signal. *Id.* at 16.

In response to the argument presented by Rovi’s declarant, Dr. Shamos, that Sato’s personal computer 105 would be configured to use server software to receive and forward hypertext commands, but would not use a browser, Comcast contends that just because Sato’s personal computer 105 supports external access does not mean that it cannot allow users to control home electronic devices using a browser. Pet. Reply 16 (citing PO Resp. 33; Ex. 2111 ¶¶ 134–136, 147). Relying on the testimony of Dr. Tjaden, Comcast argues that a person of ordinary skill in the art would have understood that Sato’s personal computer 105 includes a browser that allows

it to control home electronic devices, as well as a server component that allows it to receive hypertext commands from external portable computer 107 and execute those commands. *Id.* (citing Ex. 1152 ¶¶ 35, 49–53). Comcast, once again, reiterates that control software on Sato’s personal computer 105, collectively with the browser that renders a webpage of a program guide display, is considered properly as part of the extensive arrangement of software that makes up the claimed “local interactive television program guide.” *Id.* at 16–17 (emphasis omitted) (citing Ex. 1152 ¶¶ 54, 55; Ex. 1154 ¶ 169).

As we explained previously, a proper obviousness evaluation requires reading Sato, as a whole. *See Hedges*, 783 F.2d at 1041. Indeed, it would be improper for us to focus solely on Sato’s Figure 17 and its corresponding description at the exclusion of other disclosures in Sato that are necessary to fully appreciate what Sato suggests to one of ordinary skill in the art about certain components in this figure, such as personal computer 105. *See id.*

Upon reading Sato, as a whole, we agree with Comcast that Sato renders communication between the claimed “local/remote access interactive television program guides” obvious because control software operating on Sato’s personal computer 105, which also includes a browser operating thereon, receives hypertext commands from external portable computer 107 and issues appropriate commands to local hardware. *See Pet.* 35. In our previous analysis, we noted that Sato’s Figure 17 and its corresponding description indicate that external portable computer 107 sends hypertext commands to personal computer 105 through Internet 106. Ex. 1115, 9:56–61. After personal computer 105 receives these hypertext commands, they are then sent to interface box 104, which, in turn, generates infrared signals

responsive to the commands that are used to control a number of home electronic devices (e.g., TV receiver 101, illuminator 102, air conditioner 113, or any other electronic device, such as VTR 11). *Id.* at 9:45–55, 9:61–65.

Although the corresponding description of Sato’s Figure 17 is silent with respect to how personal computer 105 receives hypertext commands from external portable computer 107 and issues appropriate commands to local hardware, other disclosures in Sato provide a full appreciation as to how personal computer 105 operates in this regard. For instance, after reading Sato in its entirety, one of ordinary skill in the art would have recognized that there is a corollary between personal computer 21 illustrated in Figure 1 and personal computer 105 illustrated in Figure 17. Sato discloses that, when personal computer 21 is connected to Internet 6, it receives hypertext commands for determining the behavior of home electronic devices through input/output (“I/O”) interface 40. Ex. 1115, 5:45–49, Fig. 5. Browser 41 operating on personal computer 21 “deals with the hypertext [commands] to link text [to] data,” which entails moving image data, audio data, and so forth to form a multimedia picture. *Id.* at 5:50–53, Fig. 5. When a user selects a hypertext command in the multimedia picture using a mouse or keyboard, that command is transmitted from command transmitter 44 to interface box 25. *Id.* at 6:5–9. Given these disclosures regarding personal computer 21 illustrated in Figure 1, we find that one of ordinary skill in the art would have understood that personal computer 105 illustrated in Figure 17 receives hypertext commands via an I/O interface (i.e., control software) and then transmits a selected command via a command transmitter to local hardware in the same way that personal

computer 21 receives hypertext commands via I/O interface 40 and transmits a selected command via command transmitter 44 to local hardware.

Comcast's declarant, Dr. Tjaden, provides testimony that supports our finding that one of ordinary skill in the art would have understood that an I/O interface (i.e., control software) operating on Sato's personal computer 105 receives hypertext commands from external portable computer 107 and issues appropriate commands to local hardware. In his Declaration accompanying the Petition, Dr. Tjaden testifies that Sato's external portable computer 107 and personal computer 105 communicate with each other because "control software on the [personal computer 105] would operate to receive the commands from the external portable computer [107] over the Internet [106], process the received commands and output them from the interface box [104] to local hardware." Ex. 1102 ¶ 153 (citing Ex. 1115, 5:19–22, 9:51–65); Ex. 1152 ¶ 35 (testifying the same). We credit the aforementioned testimony of Dr. Tjaden because it is consistent with reading Sato, as a whole, without viewing the corresponding description of Sato's Figure 17 at the exclusion of other teachings in Sato that provide a full appreciation as to how personal computer 105 uses an I/O interface to receive hypertext commands from external portable 107.

Our finding in this regard also comports with our construction of "interactive television program guide." In our claim construction section above, we determine that the broadest reasonable interpretation of an "interactive television program guide" is "control software operative at least in part to generate a display of television program listings and allow a user to navigate through the listings, make selections, and control functions of the software." *See supra* Section II.A. We clarify that neither the intrinsic nor

extrinsic record limits the “guide” to a single software application. *See supra* Section II.A. Consequently, we find that the I/O interface (i.e., control software) operating on Sato’s personal computer 105 that receives hypertext commands from external portable computer 107, together with the browser operating on Sato’s personal computer 105 that renders a webpage of a program guide display, collectively teaches a “local interactive television program guide” because (1) these software applications work together to display program listings and allow the user to navigate through the listings, make selections, and control recording functions; and (2) more than one software application may constitute a “guide.”

We do not agree with Rovi’s arguments that Comcast only relies on communication between browsers operating on external portable computer 107 and personal computer 105 to account for communication between two interactive television program guides because they do not characterize Comcast’s position with respect to this limitation accurately. *See* PO Resp. 30–33. As we explain above, Comcast contends—and we agree—that control software for receiving hypertext commands on Sato’s personal computer 105, together with the browser that renders a webpage of a program guide display, falls within a permissible arrangement of software that constitutes the claimed “local interactive television program guide.” *See* Pet. 35; Pet. Reply 13–17. That is, we find that one of ordinary skill in the art would have understood that Sato’s personal computer 105 includes both an I/O interface (i.e., control software) and a browser application. Together, these software applications constitute the “local interactive television program guide” because they (1) receive hypertext communication from the “remote access interactive television program guide” (i.e., the browser

operating on Sato's personal computer 107 that, when rendering a webpage that includes a program guide display such as the one illustrated in Figure 2, allows a user to record desired programs); and (2) work together to display program listings and allow the user to navigate through the listings, make selections, and control recording functions.¹²

We also do not agree with Rovi's characterization of Sato's personal computer 105 as merely a conduit that receives hypertext commands for external portable computer 107 and passes those commands to interface box 104, without any processing by personal computer 105 itself. *See* PO Resp. 32–33. Sato discloses that personal computer 21 does not just receive hypertext commands through I/O interface 40 and pass them to interface box 25, without any additional processing. Instead, upon receipt of the hypertext commands through I/O interface 40, browser 41 formulates the commands into a webpage for display to the user and, once a selection is made, command transmitter 44 transmits the selected command to interface box 25.

¹² We recognize that, in our Decision on Institution, we stated that we were persuaded that Comcast had presented “sufficient evidence that would support a finding that Sato's browsers operating on personal computer 105 and external portable computer 107 communicate with each other in the manner required by the independent claims.” Dec. on Inst. 21–22. We note that the Petition contends that, in Sato, “[c]ontrol software on [personal computer 105] (which includes the browser – local guide) receives the hypertext command from the external portable computer [107] and issues appropriate commands to local hardware.” Pet. 35 (citing Ex. 1115, 9:56–65; Ex. 1102 ¶¶ 152–154). Comcast addressed this point extensively in its Petitioner Reply (Pet. Reply 13–18), and Rovi did not request a sur-reply. Comcast also made this point at the oral hearing (Hearing Tr. 37:5–10), and Rovi had ample opportunity to address it at the oral hearing (*id.* at 78:18–80:6).

Ex. 1115, 5:45–53; 6:5–9, Fig. 5. Given that one of ordinary skill in the art would have understood that Sato’s personal computer 21 and personal computer 105 include similar components that possess the same capabilities and functionalities, we find that, when personal computer 105 receives a hypertext command from external portable computer 107, that command is processed at least through an I/O interface prior to being transmitted to interface box 104 via a command transmitter.

In his Reply Declaration, Dr. Tjaden reinforces that a certain level of processing occurs in Sato’s personal computer 105 prior to interface box 104 outputting an infrared signal to local hardware. Dr. Tjaden testifies that

[personal computer 105] would process the hypertext command prior to transmission to the interface box [104] as the hypertext commands themselves would not be suitable for direct conversion to infrared signal. Thus, control software of [personal computer 105] would receive and process the hypertext commands so as to be able to control the . . . interface box [104].

Ex. 1152 ¶ 39. The processing identified in Dr. Tjaden’s testimony is consistent with our understanding that, when Sato’s personal computer 105 receives a hypertext command from external portable computer 107, that command is processed at least through an I/O interface prior to being transmitted to interface box 104 via a command transmitter.

Rovi’s declarant, Dr. Shamos, also acknowledges that some level of processing occurs at Sato’s personal computer 105 prior to interface box 104 outputting an infrared signal to local hardware. Dr. Shamos testifies that “personal computer 105 acts like a server to receive external hypertext commands, convert them to device code and pass them to infrared interface box 104. . . . Such operations would not be conducted by a browser.”

Ex. 2111 ¶ 147. Dr. Shamos’s testimony that personal computer 105

“converts” the hypertext commands, along with his testimony that the conversion operation “would not be conducted by a browser,” also is consistent with our understanding that, when Sato’s personal computer 105 receives a hypertext command from external portable computer 107, that command is processed at least through an I/O interface prior to being transmitted to interface box 104 via a command transmitter.

Lastly, we do not agree with Rovi’s arguments that Comcast relies solely on inherency arguments to account for communication between two interactive television program guides for two reasons. *See* PO Resp. 32–33. First, Rovi’s arguments are predicated, in part, on the notion that the browsers operating on Sato’s personal computer 105 and external portable computer 107 communicate directly with each other. As we explain above, Sato’s external portable computer 107 sends hypertext commands to an I/O interface (i.e., control software) operating on personal computer 105—not the browser operating on this computer. Second, when addressing this particular issue in the Decision on Institution, we recognized that Dr. Tjaden testifies that “[personal computer 105] *would necessarily include* control software that operate[s] to access and display the program guide pages, such as a browser.” Dec. on Inst. 22 (citing Ex. 1102 ¶ 53). In our view, this cited portion of Dr. Tjaden’s testimony is directed to whether the browser operating on personal computer 105 would necessarily access and display program guide webpage—not whether personal computer 105 includes an I/O interface (i.e. control software) for receiving hypertext commands from external portable computer 107. As we explain above, we find that one of ordinary skill in the art would have understood that Sato’s personal computer 105 receives hypertext commands via I/O interface (i.e., control

software) from external portable computer 107 in the same way that personal computer 21 receives hypertext commands via I/O interface 40.

iii. Remaining Limitations

In its Patent Owner Response, Rovi does not address separately whether the combined teachings of Sato and Humpleman account for the remaining limitations recited in independent claims 1 and 10. *See generally* PO Resp. 20–34. We have reviewed Comcast’s explanations and supporting evidence as to how this proffered combination teaches these remaining limitations, and we agree with and adopt Comcast’s analysis. *See* Pet. 9–10, 27–35.

b. Comcast Presents a Sufficient Rationale to Combine the Teachings of Sato and Humpleman

Rovi contends that Comcast relies on disparate portions of Sato and Humpleman without explaining how or why one of ordinary skill in the art would have combined these disparate portions, much less how that proffered combination would have worked. PO Resp. 35 (citing Ex. 2111 ¶¶ 149–157). Rovi then presents three arguments as to why one of ordinary skill in the art would not have had sufficient reasons to combine the teachings of Sato with those of Humpleman.

First, Rovi contends that a person of ordinary skill in the art would not have been motivated to combine the teachings of Sato and Humpleman because these references are fundamentally different and incompatible. PO Resp. 35. On the one hand, Rovi argues that Humpleman is directed to a home network that creates HTML pages for each peripheral device using information stored in those devices, and uses a separate “Mini-Server” application to create an interface. *Id.* Rovi asserts that Humpleman

describes the peripherals as “home devices,” but explicitly excludes personal computers. *Id.* (citing Ex. 1106, 1:21–25). On the other hand, Rovi argues that Sato is directed to an “[I]nternet downloaded programmable remote control” that uses a browser on a computer and infrared box to control peripherals based on the transmission of hypertext commands. *Id.* at 35–36 (citing Ex. 2111 ¶¶ 48–49, 152). In addition, Rovi argues that Humpleman discusses problems with remote controls that “use static control and command logic,” whereas Sato’s system uses a static control and command device. *Id.* at 36 (quoting Ex. 1106, 1:45–67) (citing Ex. 1106, 1:58–67; Ex. 1115, 6:40–51, 6:62–7:54, 8:41–49). Consequently, Rovi asserts that Sato’s interface box 104 is a remote control that can “only control and command those home devices for which it includes the necessary control and command logic,” which is something that Humpleman sought to avoid. *Id.* at 36–37 (quoting Ex. 1106, 1:55–58) (citing Ex. 2111 ¶¶ 28, 151).

Second, Rovi contends that, because Humpleman and Sato have different principles of operation, a person of ordinary skill in the art would not have looked to combine their teachings. PO Resp. 37 (citing Ex. 2111 ¶ 152). Rovi argues that Humpleman’s principle of operation is a browser-based home network where each home electronic device connected to the network contains one or more HTML pages that provide for command and control of the home electronic device, whereas Sato’s principle of operation is the control of home electronic devices using an infrared remote control of the type that was criticized in Humpleman. *Id.* (citing Ex. 1106, 1:45–67, 23:46–49). Rovi also argues that Humpleman is directed to generating HTML pages for each home electronic device by using information stored in memory installed on those devices. *Id.* By contrast, Rovi argues that the

embodiment illustrated in Sato's Figure 17 does not access information about a home electronic device directly from that device. *Id.* at 37–38 (citing Ex. 2110, 123:18–124:10). As a result, Rovi asserts that implementing Humpleman's customized HTML pages in Sato's program guide system would change Sato's principle of operation. *Id.* (citing *In re Ratti*, 270 F.2d 810, 813 (CCPA 1959); *Plas-Pak Indus. Inc. v. Sulzer Mixpac AG*, 600 F. App'x 755, 757–59 (Fed. Cir. 2015)).

Third, Rovi contends that each of Comcast's three reasons as to why one of ordinary skill in the art would have combined the teachings of Sato with those of Humpleman do not withstand scrutiny. PO Resp. 38–39. Turning to Comcast's argument that the combination would have been nothing more than using a known technique to improve a similar device in the same way, Rovi argues that Comcast does not explain how using Humpleman's HTML program guides would offer “better access to desired information,” when Sato already discloses television listings and allows the use of G codes to control home electronic devices. *Id.* Indeed, Rovi asserts that adding Humpleman's method of customizing HTML pages could require more data, hardware, and steps because it would involve generating an HTML page for each of Sato's home electronic devices using information stored in memory on each device. *Id.* at 39 (citing Ex. 1106, 2:40–63).

In Reply, Comcast maintains that a person of ordinary skill in the art would have had sufficient reasons to combine the teachings of Sato and Humpleman. Pet. Reply 18–19 (citing Pet. 24–26, 32–33). Beginning with Rovi's argument that Sato and Humpleman are fundamentally different and incompatible, Comcast disagrees with this argument because both references are directed to systems operable to control devices from an external

computer over the Internet using program guide webpages. *Id.* at 19. Comcast also does not agree with Rovi's argument that it relies on disparate portions of Sato and Humpleman without explaining how or why a person of ordinary skill in the art would have combined their teachings, nor does Comcast agree with Rovi's argument that it has not explained how the proffered combination would work. *Id.* Comcast counters that Rovi ignores the detailed rationales to combine set forth in the Petition and the supporting testimony of Dr. Tjaden. *Id.* (citing Pet. 24–26; Ex. 1102 ¶¶ 104–108; Ex. 1152 ¶¶ 44–46). Comcast then reiterates that a person of ordinary skill in the art would have incorporated Humpleman's local generation of customized program guides for display by a remote device in Sato's program guide system to allow a user to avoid viewing a display that includes a disfavored channel or content, and to provide the user with improved access to his/her desired content. *Id.* (citing Ex. 1106, 22:43–46; Ex. 1102 ¶ 105; Ex. 1152 ¶¶ 15–16).

Comcast does not agree with Rovi's argument that Sato's program guide system involves static control and command logic that is disparaged in Humpleman's "Background of the Invention" section. Pet. Reply 20. According to Comcast, Rovi's argument in this regard incorrectly characterizes Sato as based on a single component—namely, the infrared interface (i.e., interface box 25 or 104)—without considering the other components disclosed in Sato. *Id.* Comcast argues that, even if each of Sato's interface boxes 25 and 104 could be considered a static control and command system, Rovi's incorrect characterization oversimplifies and overlooks significant portions of Sato's disclosure, such as Sato's Internet-enabled program guide system for setting recordings on local equipment. *Id.*

(citing Ex. 1115, 4:41–46, 9:8–17; Ex. 1102 ¶ 97; Ex. 1152 ¶¶ 17–19). Comcast also argues that Rovi mischaracterizes Dr. Tjaden’s supporting testimony as purportedly admitting that Sato’s interface boxes 25 and 104 use static control and command logic. *Id.* at 20–21 (citing PO Resp. 36). Contrary to Rovi’s characterization of this testimony, Comcast asserts that Dr. Tjaden never conceded that he incorrectly read Sato, but rather only indicated that adding new electronic devices to Sato’s program guide system would require Sato’s interface boxes 25 and 104 to be modified such that their code storage portions 52 would include additional infrared signal codes. *Id.* at 21 (citing Ex. 2111, 128:1–130:10; Ex. 1115, 8:35–40). Indeed, Comcast argues that modifying Sato’s program guide system in this way meshes well with Humpleman’s stated goals of improving coverage for different types and models of home electronic devices. *Id.* (citing Ex. 1152 ¶¶ 44–45).

Lastly, Comcast does not agree with Rovi’s argument that modifying Sato’s program guide system with Humpleman’s local generation of customized program guides for display by a remote device would change Sato’s principle of operation. Pet. Reply 21. Relying on Federal Circuit precedent, Comcast argues that modifying Sato with the teachings of Humpleman would not destroy the high level ability of Sato’s program guide system. *Id.* at 21–22 (citing *In re Mouttet*, 686 F.3d, 1322, 1332 (Fed. Cir. 2012)). In addition, Comcast argues that Sato’s descriptions of interface boxes 25 and 104 controlling home electronic devices is not a principle of operation as that term has been used by the Federal Circuit. *Id.* Instead, following the guidance laid out in *Mouttet*, Comcast asserts that Sato’s principle of operation would be more appropriately characterized as setting

recordings on a multimedia system using a program guide system connected to the Internet. *Id.* at 22 (citing Ex. 1152 ¶¶ 41–42).

The Supreme Court has held that an obviousness evaluation “cannot be confined by a formalistic conception of the words teaching, suggestion, and motivation, or by overemphasis on the importance of published articles and the explicit content of issued patents.” *KSR*, 550 U.S. at 419. Instead, the relevant inquiry is whether Comcast has set forth “some articulated reasoning with some rational underpinning to support the legal conclusion of obviousness.” *In re Kahn*, 441 F.3d 977, 988 (Fed. Cir. 2006), *cited with approval in KSR*, 550 U.S. at 418. When describing examples of what may constitute a sufficient rationale to combine, the Supreme Court elaborated that, “if a technique has been used to improve one device, and a person of ordinary skill in the art would recognize that it would improve similar devices in the same way, using the technique is obvious unless its actual application is beyond his or her skill.” *KSR*, 550 U.S. at 417.

Based on the record developed during trial, we agree with Comcast that one of ordinary skill in the art would have had a sufficient reason to combine Sato’s program guide system with Humpleman’s local generation of customized program guides for display by a remote device. Humpleman discloses that a user may customize the programming information that is displayed by the program guide based on user preferences. Ex. 1106, 22:41–43. For instance, if a user prefers not to display the schedule for a particular channel because it contains inappropriate content, the user may request that the channel be removed from the program guide. *Id.* at 22:43–46. Humpleman makes clear that any device that employs a browser may access the customized HTML guide, including one located remotely from the home

network via the Internet. *Id.* at 5:55–67, 6:1–18, 20:32–51; *see also* Ex. 1102 ¶ 102 (testifying the same).

With these disclosures from Humpleman in mind, we agree with Comcast that, when, as here, a technique has been used to improve one device (i.e., Humpleman’s local generation of a customized program guide for display by a remote device), and one of ordinary skill in the art would have recognized that it would improve similar devices in the same way (i.e., applying Humpleman’s technique to Sato’s program guide system to render a customized program guide as a webpage on the browser operating on Sato’s external portable computer 107), using the technique is obvious unless its actual application is beyond the skill level of an ordinary skilled artisan. *See* Pet. 24–26; Ex. 1102 ¶ 106. The record includes credible evidence explaining why applying Humpleman’s technique to Sato’s program guide system to render a customized program guide as a webpage on the browser operating on Sato’s external portable computer 107 would not have been uniquely challenging or otherwise beyond the skill level of an ordinary skilled artisan. Indeed, Humpleman itself provides the necessary motivation for doing so—namely, to allow a user to avoid viewing a display that includes a disfavored channel or content, and to provide the user with improved access to his/her desired content. Ex. 1106, 22:43–46.

We do not agree with Rovi’s argument that Sato and Humpleman are fundamentally different and incompatible. *See* PO Resp. 35–36. As an initial matter, Sato generally relates to a remote control that operates home electronic devices, including one that is capable of receiving a program guide webpage through a computer network. Ex. 1115, [54], 1:8–13, 2:6–16. Similarly, Humpleman generally relates to controlling a plurality of

home electronic devices connected to a home network. Ex. 1106, [54], 1:16–18, 2:15–28. Consequently, we find that Sato and Humpleman fall in the same field of endeavor

Dr. Tjaden’s testimony supports our finding that Sato and Humpleman are not fundamentally different and incompatible. In his Declaration accompanying the Petition, Dr. Tjaden testifies that “it would have been obvious to one of ordinary skill in the art to incorporate Humpleman’s system for locally generating customized HTML guides for display by a remote device in Sato’s remote control system to provide users with improved access to their desired content.” Ex. 1102 ¶ 105. In his Declaration accompanying the Reply, Dr. Tjaden clarifies that combining the teachings of Sato and Humpleman in this manner “would improve Sato’s [stated objective] of ‘provid[ing] a remote control device easily operated for reservations, etc. of programs and flexibly coping with changes to schedule of programs.’” Ex. 1152 ¶ 46 (quoting Ex. 1115, 2:6–9).

Contrary to Rovi’s arguments, we do not agree that Sato’s program guide system uses a static control and command logic device that is disparaged in Humpleman’s “Background of the Invention” section. *See* PO Resp. 36–37. Rovi’s argument in this regard focuses on Sato’s interface boxes 25 and 104. When taking a closer look at Humpleman’s “Background of the Invention” section, it criticizes the use of a single remote control that “allows a homeowner to control and command several different home [electronic] devices using a single interface.” Ex. 1106, 1:47–49. Humpleman discloses that such a remote control “[would] not be able to control and command . . . new home [electronic] devices that require control and command logic that was not known at the time the remote control . . .

was developed.” *Id.* at 1:62–67. These disclosures in Humpleman, however, do not mention, much less criticize, using an interface box that stores code data, which it then uses to generate infrared signals for transmission to home electronic devices, as taught by Sato.

Even if we were to assume that Sato’s interface boxes 25 and 104 have some relevance to the “static” single remote control with the single user interface that is disparaged in Humpleman’s “Background of the Invention” section, there is sufficient evidence of record to support a finding that one of ordinary skill in the art would have understood that code storage portions 52 of Sato’s infrared interface 25 and 104 are not static, but rather configured to introduce and store new code data for transmission to new home electronic devices. Sato discloses that interface box 25 includes code storage portion 52, which “stores all code data of all devices of different manufacturers.” Ex. 1115, 6:40–51, Figs. 8, 9; *see also id.* at 8:32–33 (disclosing the same). Sato recognizes that “infrared signal codes may be changed” and, therefore, discloses that “code storage portion [52] maybe configured to do both reading and writing so as to introduce code data entered from the exterior as a leaning [sic] remote controller.” *Id.* at 8:36–39. These disclosures would have been equally applicable to interface box 104.

During his deposition, Dr. Tjaden was asked whether code storage portion 52 of Sato’s infrared boxes 25 and 104 are capable of storing new code data for new home electronic devices. The relevant exchange is reproduced below:

“Q So for the Sato IR box to send a new command, the Sato IR box would have to be modified so that the code storage portion stored a new code corresponding to that command. Correct?”

A That is correct.”

Ex. 2110, 130:6–10. In his Declaration accompanying the Reply, Dr. Tjaden testifies that the aforementioned cross-examination testimony confirms that he never used the word “static” and, instead, “affirm[s] that Sato does not use ‘static control and command logic.’” Ex. 1152 ¶ 45. Dr. Tjaden further testifies that, because “Sato teaches that the IR box is modified to send new commands, . . . it is necessarily not ‘static.’” *Id.* We credit this testimony from Dr. Tjaden because it is consistent with Sato’s disclosure that new code data may be written to code storage portions 52 of interface boxes 25 and 104. Neither Rovi nor its declarant, Dr. Shamos, provide credible evidence that undermines Dr. Tjaden’s position that Sato’s interface boxes 25 and 104 are not “static” because their respective code storage portions 52 are configured to accept and store new code data for new home electronic devices.

We also do not agree with Rovi’s argument that modifying Sato’s program guide system with Humpleman’s local generation of customized program guides for display on a remote device would change Sato’s principle of operation. *See* PO Resp. 37–38. Rovi’s argument is, once again, predicated on the notion that Sato’s infrared boxes 25 and 105 are the type of “static” remote control devices disparaged in Humpleman’s “Background of the Invention” section. For the same reasons set forth above, we do not agree that Sato’s infrared boxes 25 and 105 are the type of “static” devices disparaged in Humpleman’s “Background of the Invention”

section, but rather the evidence of record suggests that these infrared boxes are configured to accept and store new code data for new electronic devices.

There are two additional reasons that we do not agree with Rovi's argument that modifying Sato's program guide system with Humpleman's local generation of customized program guides for display by a remote device would change Sato's principle of operation. First, as we explain at length above, Comcast proposes applying Humpleman's local generation of a customized program guide for display by a remote device to Sato's program guide system to render a customized program guide as a webpage on the browser operating on Sato's external portable computer 107. In our view, combining the teachings of Sato and Humpleman in this way would have little, if any, bearing on the code data stored in code storage portions 52 of Sato's interface boxes 25 and 104 that are used to generate infrared signals for transmission to home electronic devices. Even if combining the teachings of Sato and Humpleman in the manner asserted by Comcast would affect Sato's interface boxes 25 and 104, there is sufficient evidence of record suggesting that their respective code storage portions 52 are not "static," but rather configured so as to accept and store new code data for new home electronic devices.

Second, Rovi's reliance on *Ratti* to support its change in principle of operation argument is misplaced. *See* PO Resp. 38. *Ratti* stands for the proposition that, if the combination of references would change the principle of operation of the prior art, then the teachings cannot suffice to render claims obvious. 270 F.2d at 813. *Ratti*, however, is inapplicable where the modified system still operates "on the same principles as before." *In re Umbarger*, 407 F.2d 425, 430–31 (CCPA 1969). In this case, modifying

Sato's program guide system with Humpleman's local generation of customized program guides for display by a remote device only affects how the customized program guide webpage is generated and displayed at Sato's external portable computer 107. This does not affect Sato's overall principle of operation of a remote control that operates home electronic devices, including one that is capable of receiving a program guide webpage through a computer network. Ex. 1115, [54], 1:8–13, 2:6–16.

c. Summary

In summary, Comcast has demonstrated by a preponderance of the evidence that the subject matter of independent claims 1 and 10 would have been obvious over the combined teachings of Sato and Humpleman.

6. Claims 3–9 and 12–18

In its Patent Owner Response, Rovi does not address separately whether the combined teachings of Sato and Humpleman account for the remaining limitations recited in dependent claims 3–9 and 12–18. *See generally* PO Resp. 20–41. We have reviewed Comcast's explanations and supporting evidence as to how this proffered combination teaches these limitations, as well as its explanations as to how one of ordinary skill in the art would have combined the relevant teachings of Sato with those of Humpleman, and we agree with and adopt Comcast's analysis. *See* Pet. 9–10, 35–41. Comcast, therefore, has demonstrated by a preponderance of the evidence that the subject matter of dependent claims 3–9 and 12–18 would have been obvious over the combined teachings of Sato and Humpleman.

*C. Obviousness Over the Combined Teachings of
Sato, Humpleman, and Lawler*

Comcast contends that claims 2 and 11 of the '413 Patent are unpatentable under § 103(a) over the combined teachings of Sato, Humpleman, and Lawler. Pet. 41–42. Comcast explains how this proffered combination teaches or suggests the subject matter of each challenged claim, and provides reasoning as to why one of ordinary skill in the art would have been prompted to modify or combine the references' respective teachings. *Id.* Comcast also relies upon the Declaration of Dr. Tjaden to support its positions. Ex. 1102 ¶¶ 177–181. In its Patent Owner Response, Rovi contends that (1) Lawler does not account for the claimed “local/remote access interactive television guides” in communication with each other and, therefore, Lawler does not remedy the purported deficiencies in the combined teachings of Sato and Humpleman; and (2) Comcast does not present sufficient reasoning as to why one of ordinary skill in the art would combine the teachings of Lawler with those of Sato and Humpleman. PO Resp. 41–43. Rovi relies upon the Declaration of Dr. Shamos to support his positions. Ex. 2111 ¶¶ 158–160.

We begin our analysis with a brief overview of Lawler, and then we address the parties' contentions with respect to the claims at issue in this asserted ground.

1. Lawler Overview

Lawler generally relates to a system for recording a program on an interactive viewing system and, in particular, to a system that allows a user to identify a program for recording using an interactive program guide and then designate the identified program for automated recording at some later

time. Ex. 1109, 1:8–13. According to one aspect of the invention disclosed in Lawler, the recording device is associated with a head end. *Id.* at 2:24–25. At the direction of the head end, the recording device records the selected program and digitally stores it in a memory at the head end. *Id.* at 2:25–27. The recorded program may then be retrieved from the head end by the user for display at a viewer station. *Id.* at 2:27–29. Lawler discloses that this process would allow multiple users to access a single recording of the program, as well as make the program available to other users who did not set the recording, but nonetheless wish to view the program at some later time. *Id.* at 13:34–38.

2. Claims 2 and 11

Dependent claim 2 recites “wherein the local interactive television program guide records the television program corresponding to the selected television program listing at a television distribution facility.” Ex. 1101, 40:48–51. Dependent claim 11 recites a similar limitation. *Id.* at 42:12–15.

In its Petition, Comcast contends that Lawler teaches recording programs at a head end (i.e., a television distribution facility) in lieu of recording programs locally. Pet. 41–42 (citing Ex. 1109, 2:24–29, 13:26–38; Ex. 1102 ¶¶ 179–180). Comcast then argues that it would have been obvious to modify the Sato and Humpleman combination to include recording programs at a television distribution facility, as taught by Lawler, because there are certain advantages to recording programs at the television distribution facility, such as making recorded programs available for other subscribers and eliminating the need for a separate recorder. *Id.* at 42 (citing Ex. 1102 ¶ 181). According to Comcast, this proffered combination would be nothing more than using a known technique (i.e., Lawler’s centralized

recording at a television distribution facility) to improve a similar system (i.e., the combined Sato and Humpleman remote access system), and would produce a predictable result that provides the stated benefits of Lawler. *Id.*

In its Patent Owner Response, Rovi contends that Lawler does not account for the claimed “local/remote access interactive television guides” in communication with each other and, therefore, Lawler does not remedy the purported deficiencies in the combined teachings of Sato and Humpleman. PO Resp. 41–42 (citing Ex. 1109, 5:38–42, 6:37–41, 7:3–5). We do not agree with this argument because, as we explain previously in our analysis of the ground based on the combined teachings of Sato and Humpleman, Sato teaches the claimed “local/remote access interactive television guides” in communication with each other. *See supra* Section II.B.5.a.i–ii. Consequently, there are no deficiencies in the combined teachings of Sato and Humpleman for Lawler to remedy.

Next, Rovi contends that Comcast’s explanations for combining the teachings of Sato, Humpleman, and Lawler are conclusory and fail to provide a sufficient reason for making the proffered combination. PO Resp. 42 (citing Ex. 2111 ¶¶ 158–160). According to Rovi, Comcast fails to explain how or why one of ordinary skill in the art would have incorporated Lawler’s technique for recording programs at a television distribution facility into the combined program guide system of Sato and Humpleman. *Id.* In particular, Rovi argues that Comcast does not explain how a person of ordinary skill in the art would have moved the recorder to Lawler’s television distribution facility, while still maintaining the operability of the combined program guide system of Sato and Humpleman, including the ability for the user to control operations of Sato’s VTR 11 using interface

box 25, both of which are local to the user's system. *Id.* at 43. Rovi further argues that Comcast does not explain how the combined program guide system of Sato and Humpleman would be modified to send hypertext commands to Lawler's television distribution facility. *Id.*

In its Reply, Comcast counters that Lawler's centralized recording still would allow the user to view recorded content at his/her home using the combined program guide system of Sato and Humpleman. Pet. Reply 23. Comcast argues that integrating this teaching in Lawler into the combined program guide system of Sato and Humpleman would provide the added advantage of allowing the physical storage of content to occur at Lawler's television distribution facility, which was, and remains, a well-known method for increasing storage efficiency. *Id.* (citing Ex. 1152 ¶ 47).

As an initial matter, Rovi does not address separately Comcast's explanations and supporting evidence as to how the combined teachings of Sato, Humpleman, and Lawler account for the limitations of dependent claims 2 and 11. *See generally* PO Resp. 41–44. We have reviewed Comcast's explanations and supporting evidence as to how this proffered combination teaches these limitations, and we agree with and adopt Comcast's analysis. *See* Pet. 41–42.

Based on the record developed during trial, we agree with Comcast that one of ordinary skill in the art would have had a sufficient reason to modify the combined program guide system of Sato and Humpleman to include recording programs at a television distribution facility, as taught by Lawler. When, as here, a technique has been used to improve one device (i.e., Lawler's centralized recording at a television distribution facility), and one of ordinary skill in the art would have recognized that it would improve

similar devices in the same way (i.e., applying Lawler’s technique to the combined program guide system of Sato and Humpleman to make recorded programs available for other subscribers and to eliminate the need for a separate recorder), using the technique is obvious unless its actual application is beyond the skill level of an ordinary skilled artisan. *See* Pet. 36–37; Ex. 1102 ¶¶ 177–181. The record includes credible evidence explaining why applying Lawler’s technique to the combined program guide system of Sato and Humpleman to make recorded programs available to multiple subscribers at a television distribution facility would not have been uniquely challenging or otherwise beyond the skill level of an ordinary skilled artisan. Indeed, Lawler itself provides the necessary motivation for doing so—namely, “[to] allow multiple users to access a single recording of the program.” Ex. 1109, 13:33–35.

We do not agree with Rovi’s argument that Comcast does not explain how a person of ordinary skill in the art would have moved the recorder to Lawler’s television distribution facility, while still maintaining the operability of the combined program guide system of Sato and Humpleman. PO Resp. 43. As Comcast explains in the Petition, modifying the Sato and Humpleman combination to include recording programs at a television distribution facility, as taught by Lawler, serves as a substitute for the user’s ability to record programs locally on Sato’s VTR 11 using interface boxes 25 or 104. *See* Pet. 42. For instance, instead of using interface boxes 25 or 104 to instruct Sato’s VTR 11 to record programs, which still remains a viable option, a user would communicate with Lawler’s television distribution facility to record programs via Sato’s external portable computer 107 or personal computer 105. Dr. Tjaden testifies—and we agree—that

recording programs at Lawler's television distribution facility, in lieu of recording programs locally on Sato's VTR 11, would increase storage efficiency by making these recordings available to other users and it would eliminate the need for each user to maintain a separate recorder. *See* Ex. 1102 ¶ 181; Ex. 1152 ¶ 47.

We also do not agree with Rovi's argument that Comcast does not explain how the combined program guide system of Sato and Humpleman would be modified to send commands to Lawler's television distribution facility. *See* PO Resp. 43. Instead, the evidence of record supports that Lawler's television distribution facility would be capable of receiving commands from the combined program guide system of Sato and Humpleman. In particular, Dr. Tjaden testifies that "[o]ne of ordinary skill in the art would readily recognize that [the] arrangement [disclosed in Lawler] is typical of cable or satellite systems such as those disclosed in Sato and Humpleman." Ex. 1102 ¶ 179. Moreover, Rovi seeks a particular explanation as to "what specific component would be used to make the communication and the format of that communication." PO Resp. 43. Lawler, however, does not restrict the network by which the viewer stations and television distribution facility communicate to any particular type of network. Ex. 1109, 5:29–36. Similarly, the '413 Patent does not restrict how program guide information may be communicated between remote program guide access device 24 and interactive television program guide equipment 17. Ex. 1101, 15:63–16:4 (disclosing that program guide information may be communicated using "any suitable application layer protocol"). Because neither Lawler nor the '413 Patent limits the means of communication, we find that a person of ordinary skill in the art would have

understood that the combined program guide system of Sato and Humpleman would have been capable of communicating commands to Lawler's television distribution facility via a network, such as Sato's Internet 106, for the purpose of recording programs at the television distribution facility.

In summary, Comcast has demonstrated by a preponderance of the evidence that the subject matter of dependent claims 2 and 11 would have been obvious over the combined teachings of Sato, Humpleman, and Lawler.

*D. Obviousness Over the Combined Teachings of
Woo, Mizuno, and Rzeszewski*

Comcast contends that claims 1, 3–10, and 12–18 of the '413 Patent are unpatentable under § 103(a) over the combined teachings of Woo, Mizuno, and Rzeszewski. Pet. 42–71. Comcast explains how this proffered combination teaches or suggests the subject matter of each challenged claim, and provides reasoning as to why one of ordinary skill in the art would have been prompted to modify or combine the references' respective teachings. *Id.* Comcast also relies upon the Declaration of Dr. Tjaden to support its positions. Ex. 1102 ¶¶ 188–270. As we explain in our Introduction section above, the parties waived both briefing on this ground, as well as consideration of this ground at the consolidated oral hearing. *See supra* Section I.

We begin our analysis with brief overviews of Woo, Mizuno, and Rzeszewski, and then we address whether Comcast provides a sufficient rationale for combining the teachings of Woo and Mizuno.

1. *Woo Overview*

Woo generally relates to controlling a recording device that receives commercial broadcasts and, in particular, to eliminating commercials from recorded TV broadcasts. Ex. 1116, 1:7–11. According to Woo, a user selects a desired TV program for recording from a menu, and selects whether to record the program commercial-free. *Id.* at 1:43–45. One feature offered by Woo allows a user who has not selected a particular channel for recording to call in by telephone to a control station, which, based on the direction of the user, enters appropriate data into the user’s processor in order to record a desired program. *Id.* at 2:17–21.

Figure 1 of Woo, reproduced below, illustrates an embodiment of the broadcast recording control system in accordance with the present invention. Ex. 1116, 2:39–41, 2:55–57.

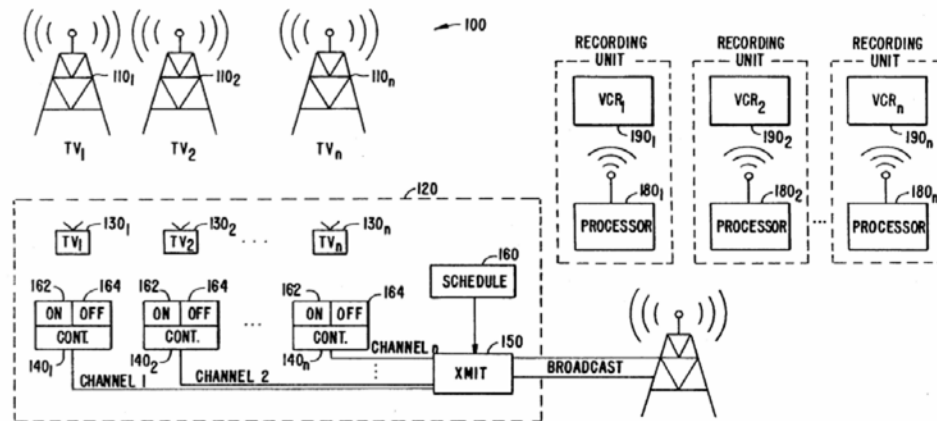

FIG. 1.

As shown in Figure 1 reproduced above, system 100 includes control station 120 with a plurality of TV monitors 130, a plurality of controllers 140, transmitter 150, and scheduler 160. *Id.* at 2:59–62. Scheduler 160 develops a TV program schedule table of future TV broadcasts. *Id.* at 3:8–10. The TV program schedule table identifies TV broadcasts by name, channel, and

day of the week. *Id.* at 3:10–12. System 100 also includes a plurality of processors 180, each of which is associated with one of a plurality of video cassette recorders (“VCRs”) 190. *Id.* at 3:28–30.

Figure 4 of Woo, reproduced below, illustrates the display of processor 180 depicted in Figure 1 of Woo. Ex. 1116, 2:46, 6:51–53.

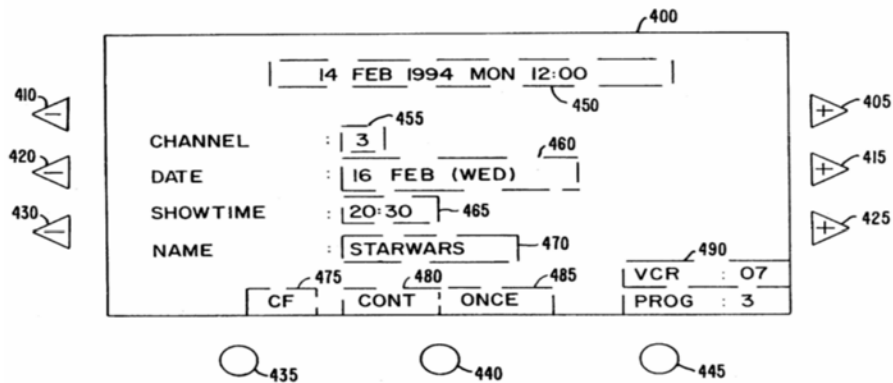
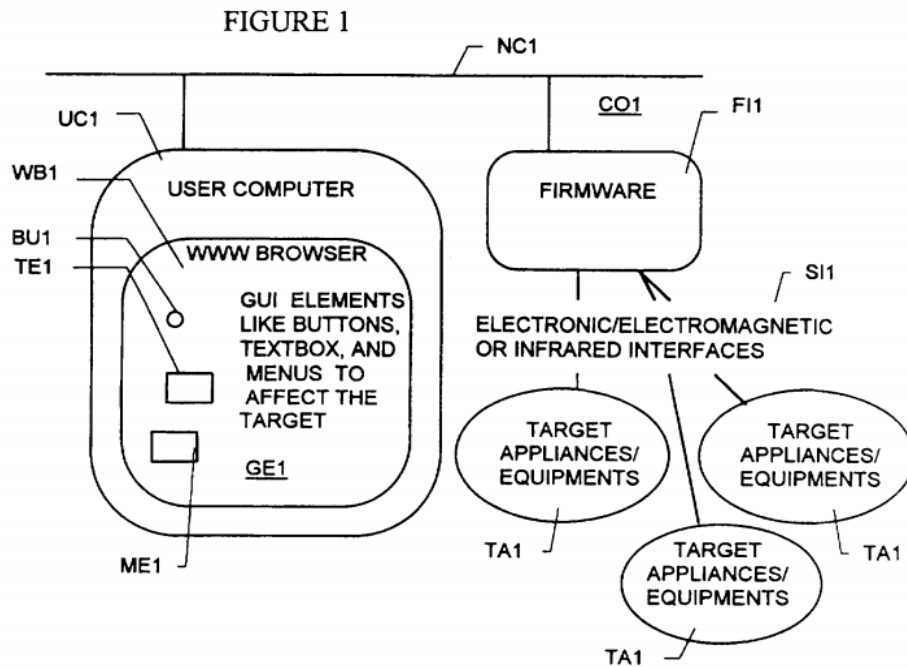

FIG. 4.

As shown in Figure 4 reproduced above, display 400 includes, among other things, date/time field 450 to display the present date and time. *Id.* at 6:62–63. Display 400 also includes a number of fields for accessing the TV program schedule table, such as channel field 455, date field 460, “showtime” field 465, and “showname” field 470. *Id.* at 6:63–7:10.

2. Mizuno Overview

Mizuno generally relates to controlling remote devices at remote locations via the Internet, preferably using hypertext transfer protocol. Ex. 1117, 1:4–8. In one embodiment, Mizuno discloses a controller that serves HTML pages to remote user computers for controlling a number of devices located in a home, such as TVs and VCRs. *Id.* at 1:24–2:12. Figure 1 of Mizuno, reproduced below, illustrates a block diagram of the system architecture used to implement this embodiment.



As shown in Figure 1 above, user computer UC1 uses ethernet network connection NC1 to connect to controller CO1 composed of firmware FI1, which, in turn, connects to a number of target appliances/equipment (e.g., TVs, VCRs, etc.). *Id.* at 3:7–10. User computer UC1 includes WWW browser WB1 that includes graphical interface elements GE1, such as buttons BU1, textbox TE1, and menus ME1 that may be used to control the target appliances/equipment TA1. *Id.* at 3:15–18. Controller CO1 creates a web page of TV listings, which, when served to user computer UC1 via WWW browser WB1, allows the user to control target appliances/equipment TA1 (e.g., by programming a VCR to record a future TV program). *Id.* at 9:20–10:4.

3. Rzeszewski Overview

Rzeszewski generally relates to electronic program guides for TV receivers and, in particular, to an improved electronic TV program guide that offers flexibility, versatility, and cost savings over conventional electronic

TV program guides. Ex. 1118, 1:6–10. One feature offered by Rzeszewski’s improved electronic TV guide is a “Favorite Station” feature that stores certain channels pre-selected by a user. *Id.* at 5:38–45.

4. Claims 1 and 10

In its Petition, Comcast contends that Woo’s broadcast recording control system accounts for most of the limitations recited in independent claims 1 and 10, except a “remote program guide access device” that provides a “remote access interactive television guide,” and “user profiles” used to generate the “remote access interactive television program guide.” Pet. 43–49 (citing Ex. 1116, 1:42–50, 2:9–30, 3:7–18, 6:50–7:1, 7:50–65, 8:25–32, 9:56–63, Figs. 1, 4; Ex. 1102 ¶¶ 188–192). Comcast turns to Mizuno’s remote access guide web pages displayed on user computer UC1 to teach a “remote program guide access device” that provides a “remote access interactive television guide.” *Id.* at 45–46 (citing Ex. 1117, 1:24–2:12, 5:19–22, 9:20–10:8, 10:18–11:3, Fig. 1; Ex. 1102 ¶ 193). Comcast turns to Rzeszewski’s “favorite station” feature to teach “user profiles” used to generate the “remote access interactive television program guide.” *Id.* at 48–49 (citing Ex. 1118, 1:6–10, 5:32–45; Ex. 1102 ¶¶ 195–198, 203).

Of particular importance to this ground is Comcast’s argument that it would have been obvious to one of ordinary skill in the art to automate Woo’s manual call-in scheduling process by using Mizuno’s remote access guide web pages. Pet. 47–48. According to Comcast, there are at least three reasons as to why one of ordinary skill in the art would have combined the teachings of Woo and Mizuno in this manner. Those reasons are listed as follows: (1) supplementing Woo’s manual call-in scheduling process with Mizuno’s remote access guide web pages is nothing more than automating a

manual process, which has long been recognized as insufficient to distinguish over prior art systems; (2) using Mizuno's remote access guide web pages to improve Woo's manual call-in scheduling process would be nothing more than using known techniques to improve similar devices to obtain a predictable result; and (3) it would have been a simple substitution of Mizuno's remote access guide web pages for Mizuno's human operator for the manual call-in process to obtain a predictable result. *Id.* (citing Ex. 1102 ¶¶ 197–199).

We do not agree that Comcast or Dr. Tjaden provides sufficient reasoning as to how or why one of ordinary skill in the art would have replaced Woo's manual call-in scheduling process with Mizuno's remote access guide web pages to arrive at the claimed invention. As an initial matter, we do not view supplementing Woo's manual call-in scheduling process with Mizuno's remote access guide web pages as simply automating a manual process. Comcast's proffered combination requires the wholesale insertion of a new component—in this case, Mizuno's user computer UC1 that displays remote access guide web pages—in Woo's broadcast recording control system. In our view, this goes beyond simply automating a manual process, but rather requires a significant modification to the structure and operations of Woo's broadcast recording control system. For instance, Comcast does not explain how Woo's controller 120, which uses transmitter 150 to broadcast control and programming information (Ex. 1116, 3:20–28), is capable of connecting to the Internet such that it could serve HTML pages to Mizuno's user computer UC1.

Nor do we agree that combining the teachings of Woo and Mizuno in the manner proposed by Comcast is nothing more than using known

techniques to improve a similar device in the same way, or is a simple substitution of one known element for another to obtain a predictable result. Comcast’s assertions in this regard are predicated on the benefits associated with automation. *See* Pet. 47 (stating “[t]his would obtain the predictable benefits associated with automation described above”), 48 (stating the same); Ex. 1102 ¶¶ 198–199 (stating the same). As we explain above, supplementing Woo’s manual call-in scheduling process with Mizuno’s remote access guide web pages goes beyond simply automating a manual process—it requires significant modifications to the structure and operations of Woo’s broadcast recording control system. Moreover, by simply providing generic reasons for combining the teachings of Woo and Mizuno, such as using “known techniques to improve similar devices” (Pet. 47) and “simple substitution” (*id.* at 48), Comcast does not adequately address the issue of rationale to combine in this ground because it fails to explain how one of ordinary skill in the art would have modified Woo’s broadcast recording control system to include Mizuno’s remote access guide web pages. *See Belden Inc. v. Berk-Tek LLC*, 805 F.3d 1064, 1073 (Fed. Cir. 2015) (“[O]bviousness concerns whether a skilled artisan . . . *would have been motivated to make* the combinations or modifications of prior art to arrive at the claimed invention.”).¹³

¹³ Because we determine that Comcast does not provide sufficient reasoning for combining the teachings of Woo and Mizuno, we need not reach whether Comcast also provides sufficient reasoning for combining the teachings of Rzeszewski with those of Woo and Mizuno.

In summary, Comcast has not demonstrated a reasonable likelihood that it will prevail on its assertion that the subject matter of independent claims 1 and 10 would have been obvious over the combined teachings of Woo, Mizuno, and Rzeszewski.

5. Claims 3–9 and 12–18

Because we determine that Comcast does not provide sufficient reasoning for combining the teachings of Woo and Mizuno, Comcast has not demonstrated a reasonable likelihood that it would prevail on its assertion that the subject matter of dependent claims 3–9 and 12–18 would have been obvious over the combined teachings of Woo, Mizuno, and Rzeszewski.

E. Obviousness Over the Combined Teachings of Woo, Mizuno, Rzeszewski, and Lawler

Comcast also contends that claims 2 and 11 of the '413 Patent are unpatentable under § 103(a) over the combined teachings of Woo, Mizuno, Rzeszewski, and Lawler. Pet. 71–72. This ground relies upon Comcast's argument that it would have been obvious to one of ordinary skill in the art to automate Woo's manual call-in scheduling process by using Mizuno's remote access guide web pages. *Id.* at 47–48 (citing Ex. 1102 ¶¶ 197–199). Because we determine that Comcast does not provide sufficient reasoning for combining the teachings of Woo and Mizuno, Comcast has not demonstrated a reasonable likelihood that it would prevail on its assertion that the subject matter of dependent claims 2 and 11 would have been obvious over the combined teachings of Woo, Mizuno, Rzeszewski, and Lawler.

III. CONCLUSIONS

Comcast has demonstrated by a preponderance of the evidence that (1) claims 1, 3–10, and 12–18 are unpatentable under § 103(a) over the combined teachings of Sato and Humpleman; and (2) claims 2 and 11 are unpatentable under § 103(a) over the combined teachings of Sato, Humpleman, and Lawler. Comcast, however, has not demonstrated by a preponderance of the evidence that (1) claims 1, 3–10, and 12–18 are unpatentable under § 103(a) over the combined teachings of Woo, Mizuno, and Rzeszewski; and (2) claims 2 and 11 are unpatentable under § 103(a) over the combined teachings of Woo, Mizuno, Rzeszewski, and Lawler.

IV. ORDER

In consideration of the foregoing, it is

ORDERED that claims 1–18 of the '413 Patent are held to be unpatentable; and

FURTHER ORDERED that, because this is a Final Written Decision, parties to this proceeding seeking judicial review of our decision must comply with the notice and service requirements of 37 C.F.R. § 90.2.

IPR2017-01049
Patent 8,578,413 B2

For PETITIONER:

Frederic M. Meeker
Bradley C. Wright
Scott M. Kelly
Azuka C. Dike
Joshua Davenport
Camille Sauer
Bennett A. Ingvoldstad
BANNER AND WITCOFF, LTD.
fmeeker@bannerwitcoff.com
bwright@bannerwitcoff.com
skelly@bannerwitcoff.com
adike@bannerwitcoff.com
jdavenport@bannerwitcoff.com
csauer@bannerwitcoff.com
bingvoldstad@bannerwitcoff.com

For PATENT OWNER:

Mark D. Rowland
Gabrielle E. Higgins
Scott A. McKeown
Scott S. Taylor
Andrew Sutton
James Batchelder (*pro hac vice*)
Josef Schenker (*pro hac vice*)
Henry Huang (*pro hac vice*)
David Chun (*pro hac vice*)
ROPES & GRAY LLP
Mark.Rowland@ropesgray.com
Gabrielle.Higgins@ropesgray.com
Scott.McKeown@ropesgray.com
Scott.Taylor@ropesgray.com
Andrew.Sutton@ropesgray.com
James.Batchelder@ropesgray.com
Josef.Schenker@ropesgray.com
Henry.Huang@ropesgray.com
David.chun@ropesgray.com