

1 BARCELÓ, HARRISON & WALKER, LLP
2 Reynaldo C. Barceló (199741)
3 rey@bhiplaw.com
4 2901 West Coast Hwy, Suite 200
5 Newport Beach, California 92663
6 Telephone: (949) 340-9736
7 Facsimile: (949) 258-5752

8
9 Attorneys for Plaintiff,
10 TMI PRODUCTS, INC.

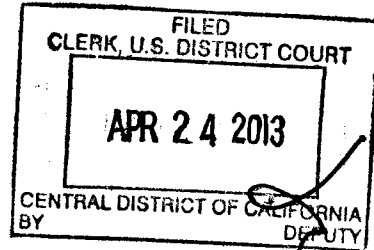

11 UNITED STATES DISTRICT COURT
12 FOR THE CENTRAL DISTRICT OF CALIFORNIA
13 WESTERN DIVISION

14 TMI PRODUCTS, INC.,

15 Plaintiff,

16 v.

17 ROSEN ELECTRONICS, L.P., f/k/a
18 ROSEN ENTERTAINMENT
19 SYSTEMS, L.P.,

20 Defendant.

Case No. 5:12-cv-02263-RGK-SP

**TMI PRODUCT INC.'S
[PROPOSED] FIRST AMENDED
COMPLAINT FOR PATENT
INFRINGEMENT**

21
22
23
24
25
26
27
28

1 For its complaint against Rosen Electronics, L.P. , formerly known as Rosen
2 Entertainment Systems, L.P. and (collectively, “Rosen,” or “Defendant”), Plaintiff
3 TMI Products, Inc. (“TMI”) alleges as follows:

4 **THE PARTIES**

5 1. TMI is a corporation duly organized and existing under the laws of the
6 California, with its principal place of business at 1493 E. Bentley Drive, Corona,
7 California 92879. TMI holds an exclusive license to U.S. Patent Nos. 7,040,697
8 (“the ’697 patent”) and 7,407,227 (“the ’227 patent”) (collectively, “the Patents in
9 Suit”). TMI’s exclusive license includes the exclusive world-wide rights to
10 sublicense the ’697 and ’227 patents, and to enforce the ’697 and ’227 patents
11 against alleged infringers. TMI is also the owner by assignment of U.S. Patent No.
12 7,597,393 (“the ’393 patent”), and as such holds the exclusive world-wide rights to
13 license the ’393 patents, and to enforce the ’393 patent against alleged infringers.

14 2. Upon information and belief, Rosen is a partnership organized and
15 existing under the laws of the State of California, with its principal place of business
16 at 1120 California Avenue, Corona, California 92881. On information and belief,
17 Rosen Electronics, L.P. , was formerly known as Rosen Entertainment Systems,
18 L.P., as a result of a name change in 2012.

19 **NATURE OF THE ACTION**

20 3. In this civil action, TMI seeks damages and injunctive relief against
21 Defendant for acts of patent infringement in violation of the Patent Act of the United
22 States, 35 U.S.C. §§ 1 et seq.

23 **JURISDICTION AND VENUE**

24 4. This Court has subject matter jurisdiction pursuant to the provisions of
25 28 U.S.C. §§ 1331 and 1338(a), because this is an action for patent infringement
26 arising under the laws of the United States, including 35 U.S.C. §§ 1 et seq.

27 5. Venue is proper under 28 U.S.C. §§ 1391(c) and 1400(b), in that the
28 acts and transactions complained of herein were conceived, carried out, made

1 effective, or had effect within the State of California and within this Judicial
2 District, among other places.

3 6. On information and belief, Rosen resides in this Judicial District by
4 virtue of its business activities in this Judicial District. For example, and without
5 limitation, on information and belief, Rosen is licensed to do business in California
6 by the California Secretary of State, and Rosen maintains a registered agent for
7 service of process in this Judicial District.

8 7. On information and belief, Rosen markets and sells, throughout the
9 United States and including in this Judicial District, headrest mountable video
10 systems.

11 8. On information and belief, based at least on the facts stated above, this
12 Court has personal jurisdiction over Defendant.

13 **BACKGROUND**

14 9. On May 9, 2006, the United States Patent & Trademark Office duly
15 and legally issued United States Letters Patent No. 7,040,697 (“the ’697 patent”),
16 entitled “HEADREST HAVING AN INTEGRATED VIDEO SCREEN.” A true
17 and correct copy of the ’697 Patent is attached as Exhibit A and incorporated herein
18 by reference.

19 10. On August 5, 2008, the United States Patent & Trademark Office duly
20 and legally issued United States Letters Patent No. 7,407,227 (“the ’227 patent”),
21 entitled “HEADREST HAVING AN INTEGRATED VIDEO SCREEN.” A true
22 and correct copy of the ’227 Patent is attached as Exhibit B and incorporated herein
23 by reference.

24 11. On October 6, 2009, the United States Patent & Trademark Office duly
25 and legally issued United States Letters Patent No. 7,597,393 (“the ’393 patent”),
26 entitled “HEADREST/HEAD RESTRAINT HAVING AN INTEGRATED VIDEO
27 SCREEN.” A true and correct copy of the ’393 Patent is attached as Exhibit C and
28 incorporated herein by reference.

1 **FIRST CLAIM FOR RELIEF**

2 **(Infringement of U.S. Patent No. 7,040,697)**

3 12. TMI incorporates herein by reference the allegations set forth in
4 paragraphs 1-11 of this Complaint as though fully set forth herein.

5 13. On information and belief, Calli Ventosa, Inc. and Tierra Vista Corp.
6 are the joint legal owners by assignment of the '697 patent from Timely
7 Innovations, LP, which is the original assignee listed on the front page of the '697
8 patent. TMI is the exclusive licensee of the '697 patent, having acquired from Calli
9 Ventosa, Inc. and Tierra Vista Corp. substantially all rights in the '697 patent,
10 including the exclusive world-wide right to sublicense the '697 patent and to enforce
11 the '697 patent against any and all infringers.

12 14. Defendant has directly infringed and continues to directly infringe the
13 '697 Patent by making, using, selling, or offering for sale in or importing into the
14 United States mobile video headrest systems that embody or otherwise practice one
15 or more of the claims of the '697 Patent, such as, without limitation, products and
16 systems marketed as the "AV7000 Dual DVD Headrest Replacement System," the
17 "AV7500 Dual DVD Headrest Replacement System," and the "AV7900 'Quick-
18 Change' Headrest Series."

19 15. On information and belief, Defendant has indirectly infringed and
20 continues to indirectly infringe the '697 Patent by actively inducing direct
21 infringement by other persons who operate and/or use mobile video headrest
22 systems such as, without limitation, products and systems marketed as the "AV7000
23 Dual DVD Headrest Replacement System," the "AV7500 Dual DVD Headrest
24 Replacement System," and the "AV7900 'Quick-Change' Headrest Series," or
25 otherwise practice one or more of the claims of the '697 Patent, when Defendant
26 had knowledge of the '697 Patent and knew or should have known that its actions
27 would induce direct infringement by others and intended that its actions would
28 induce direct infringement by others.

1 16. On information and belief, Defendant has indirectly infringed and
2 continue to indirectly infringe the '697 Patent by contributory infringement by
3 providing non-staple articles of commerce to others for use in an infringing system
4 or method with respect to mobile video headrest systems such as, without limitation,
5 products and systems marketed as the "AV7000 Dual DVD Headrest Replacement
6 System," the "AV7500 Dual DVD Headrest Replacement System," and the
7 "AV7900 'Quick-Change' Headrest Series," with knowledge of the '697 Patent and
8 knowledge that these non-staple articles of commerce are used as a material part of
9 the claimed inventions of the '697 Patent.

10 17. On information and belief, Defendant will continue to infringe the '697
11 Patent as alleged in this Complaint unless enjoined by this Court.

12 18. On information and belief, Defendant's infringement of the '697 patent
13 is, has been, and continues to be willful and deliberate.

14 19. As a direct and proximate result of Defendant's infringement of the
15 '697 patent, TMI has been and continues to be damaged in an amount yet to be
16 determined.

17 20. Unless Defendant and its respective officers, agents, servants, and
18 employees, and all persons acting in concert with Defendant, are enjoined from
19 infringing the '697 patent, TMI will be greatly and irreparably harmed.

20 21. By reason of the above acts, TMI is entitled to injunctive relief
21 enjoining and restraining Defendant, and its respective officers, agents, servants, and
22 employees, and all persons acting in concert with Defendant, from further
23 infringement of the '697 patent.

24 **SECOND CLAIM FOR RELIEF**

25 **(Infringement of U.S. Patent No. 7,407,227)**

26 22. TMI incorporates herein by reference the allegations set forth in
27 paragraphs 1-11 of this Complaint as though fully set forth herein.

28

1 23. On information and belief, Calli Ventosa, Inc. and Tierra Vista Corp.
2 are the joint legal owners by assignment of the '227 patent from Timely
3 Innovations, LP, which is the original assignee listed on the front page of the '227
4 patent. TMI is the exclusive licensee of the '227 patent, having acquired from Calli
5 Ventosa, Inc. and Tierra Vista Corp. substantially all rights in the '227 patent,
6 including the exclusive world-wide right to sublicense the '227 patent and to enforce
7 the '227 patent against any and all infringers.

8 24. Defendant has directly infringed and continue to directly infringe the
9 '227 Patent by making, using, selling, or offering for sale in or importing into the
10 United States mobile video headrest systems that embody or otherwise practice one
11 or more of the claims of the '227 Patent, such as, without limitation, products and
12 systems marketed as the "AV7000 Dual DVD Headrest Replacement System," the
13 "AV7500 Dual DVD Headrest Replacement System," and the "AV7900 'Quick-
14 Change' Headrest Series."

15 25. On information and belief, Defendant has indirectly infringed and
16 continues to indirectly infringe the '227 Patent by actively inducing direct
17 infringement by other persons who operate and/or use mobile video headrest
18 systems such as, without limitation, products and systems marketed as the "AV7000
19 Dual DVD Headrest Replacement System," the "AV7500 Dual DVD Headrest
20 Replacement System," and the "AV7900 'Quick-Change' Headrest Series," or
21 otherwise practice one or more of the claims of the '227 Patent, when Defendant
22 had knowledge of the '227 Patent and knew or should have known that its actions
23 would induce direct infringement by others and intended that its actions would
24 induce direct infringement by others.

25 26. On information and belief, Defendant has indirectly infringed and
26 continues to indirectly infringe the '227 Patent by contributory infringement by
27 providing non-staple articles of commerce to others for use in an infringing system
28 or method with respect to mobile video headrest systems such as, without limitation,

1 products and systems marketed as the “AV7000 Dual DVD Headrest Replacement
2 System,” the “AV7500 Dual DVD Headrest Replacement System,” and the
3 “AV7900 ‘Quick-Change’ Headrest Series,” with knowledge of the ’227 Patent and
4 knowledge that these non-staple articles of commerce are used as a material part of
5 the claimed inventions of the ’227 Patent.

6 27. On information and belief, Defendant will continue to infringe the ’227
7 Patent as alleged in this Complaint unless enjoined by this Court.

8 28. On information and belief, Defendant’s infringement of the ’227 patent
9 is, has been, and continues to be willful and deliberate.

10 29. As a direct and proximate result of Defendant’s infringement of the
11 ’227 patent, TMI has been and continues to be damaged in an amount yet to be
12 determined.

13 30. Unless Defendant and its respective officers, agents, servants, and
14 employees, and all persons acting in concert with Defendant, are enjoined from
15 infringing the ’227 patent, TMI will be greatly and irreparably harmed.

16 31. By reason of the above acts, TMI is entitled to injunctive relief
17 enjoining and restraining Defendant, and its respective officers, agents, servants, and
18 employees, and all persons acting in concert with Defendant, from further
19 infringement of the ’227 patent.

20 **THIRD CLAIM FOR RELIEF**

21 **(Infringement of U.S. Patent No. 7,597,393)**

22 32. TMI incorporates herein by reference the allegations set forth in
23 paragraphs 1-11 of this Complaint as though fully set forth herein.

24 33. TMI is the owner by assignment of the ’393 patent, and holds all
25 relevant rights pertaining to the ’393 patent, including the exclusive world-wide
26 right to license the ’393 patent and to enforce the ’393 patent against any and all
27 infringers.

28

1 34. Defendant has directly infringed and continue to directly infringe the
2 '393 Patent by making, using, selling, or offering for sale in or importing into the
3 United States mobile video headrest systems that embody or otherwise practice one
4 or more of the claims of the '393 Patent, such as, without limitation, products and
5 systems marketed as the "AV7000 Dual DVD Headrest Replacement System," the
6 "AV7500 Dual DVD Headrest Replacement System," and the "AV7900 'Quick-
7 Change' Headrest Series."

8 35. On information and belief, Defendant has indirectly infringed and
9 continues to indirectly infringe the '393 Patent by actively inducing direct
10 infringement by other persons who operate and/or use mobile video headrest
11 systems such as, without limitation, products and systems marketed as the "AV7000
12 Dual DVD Headrest Replacement System," the "AV7500 Dual DVD Headrest
13 Replacement System," and the "AV7900 'Quick-Change' Headrest Series," or
14 otherwise practice one or more of the claims of the '393 Patent, when Defendant
15 had knowledge of the '393 Patent and knew or should have known that its actions
16 would induce direct infringement by others and intended that its actions would
17 induce direct infringement by others.

18 36. On information and belief, Defendant has indirectly infringed and
19 continues to indirectly infringe the '393 Patent by contributory infringement by
20 providing non-staple articles of commerce to others for use in an infringing system
21 or method with respect to mobile video headrest systems such as, without limitation,
22 products and systems marketed as the "AV7000 Dual DVD Headrest Replacement
23 System," the "AV7500 Dual DVD Headrest Replacement System," and the
24 "AV7900 'Quick-Change' Headrest Series," with knowledge of the '393 Patent and
25 knowledge that these non-staple articles of commerce are used as a material part of
26 the claimed inventions of the '393 Patent.

27 37. On information and belief, Defendant will continue to infringe the '393
28 Patent as alleged in this Complaint unless enjoined by this Court.

1 38. On information and belief, Defendant's infringement of the '393 patent
2 is, has been, and continues to be willful and deliberate.

3 39. As a direct and proximate result of Defendant's infringement of the
4 '393 patent, TMI has been and continues to be damaged in an amount yet to be
5 determined.

6 40. Unless Defendant and its respective officers, agents, servants, and
7 employees, and all persons acting in concert with Defendant, are enjoined from
8 infringing the '393 patent, TMI will be greatly and irreparably harmed.

9 41. By reason of the above acts, TMI is entitled to injunctive relief
10 enjoining and restraining Defendant, and its respective officers, agents, servants, and
11 employees, and all persons acting in concert with Defendant, from further
12 infringement of the '393 patent.

13 **FOURTH CLAIM FOR RELIEF**

14 **(Breach of Contract)**

15 42. TMI incorporates herein by reference the allegations set forth in
16 paragraphs 1-11 of this Complaint as though fully set forth herein.

17 43. TMI Products, Inc. and Rosen Entertainment Systems, L.P. entered into
18 a written agreement, effective July 9, 2009 ("the Agreement"), which is related to
19 the other claims set forth herein. A true and correct copy of the Agreement is
20 intended to be included as Exhibit D hereto and incorporated herein by reference.
21 An application to file this exhibit under seal is being filed contemporaneously with
22 the lodging of this [Proposed] First Amended Complaint. The Agreement expressly
23 provides that its terms are to be kept confidential, other than with respect to the
24 identity of the parties and the fact that it includes a non-exclusive license.

25 44. TMI performed all terms and conditions of the Agreement, except to
26 the extent that its performance was waived, prevented or excused by the acts,
27 conduct and/or omissions of Defendants.

28

1 45. Defendants have breached at least Sections 3, 4, and 5 of the
2 Agreement. Defendants are well aware of TMI's bases for the foregoing allegation,
3 and are on notice of such. The details are set forth on the following page, which will
4 be sought to be filed under seal out of an abundance of caution.

5 //

6 //

7 //

8 //

9 //

10 //

11 //

12 //

13 //

14 //

15 //

16 //

17 //

18 //

19 //

20 //

21 //

22 //

23 //

24 //

25 //

26 //

27 //

28 //

1 //

2 (This page is intentionally left blank as a placeholder for paragraphs -, which
3 contain confidential information pursuant to the Agreement. The details are set
4 forth in a substitute page that is sought to be filed under seal contemporaneously
5 with the lodging of this [Proposed] First Amended Complaint.)

6 //

7 46. [Redacted - Filed under Seal]

8 47. [Redacted - Filed under Seal]

9 48. [Redacted - Filed under Seal]

10

11 //

12 //

13 //

14 //

15 //

16 //

17 //

18 //

19 //

20 //

21 //

22 //

23 //

24 //

25 //

26 //

27 //

28 //

1 49. As a result of the foregoing, TMI has been damaged in an amount to be
2 determined at trial, and is entitled to injunctive relief.

3 **PRAYER FOR RELIEF**

4 WHEREFORE, TMI prays for judgment against Defendant as follows:

5 1. For a judicial determination and declaration that Defendant directly
6 infringes United States Letters Patent Nos. 7,040,697, 7,407,227, and 7,597,393 by
7 making, using, offering to sell and/or selling mobile video headrest systems such as,
8 without limitation, products and systems marketed as the "AV7000 Dual DVD
9 Headrest Replacement System," the "AV7500 Dual DVD Headrest Replacement
10 System," and the "AV7900 'Quick-Change' Headrest Series";

11 2. For a judicial determination and declaration that Defendant induces
12 direct infringement of United States Letters Patent Nos. 7,040,697, 7,407,227, and
13 7,597,393;

14 3. For a judicial determination and declaration that Defendant commits
15 contributory infringement of United States Letters Patent Nos. 7,040,697, 7,407,227,
16 and 7,597,393;

17 4. For a judicial determination and decree that Defendant's infringement
18 of United States Letters Patent Nos. 7,040,697, 7,407,227, and 7,597,393 is willful;

19 5. For damages resulting from Defendant's past and present infringement
20 of United States Letters Patent Nos. 7,040,697, 7,407,227, and 7,597,393, and the
21 trebling of such damages because of the willful and deliberate nature of its
22 infringement;

23 6. For injunctive relief against further infringement of United States
24 Letters Patent Nos. 7,040,697, 7,407,227, and 7,597,393 by Defendant, its
25 respective officers, directors, shareholders, agents, servants, employees, and all
26 other entities and individuals acting in concert with the enjoined entities or on their
27 behalf;

28

1 7. For a declaration that this is an exceptional case under 35 U.S.C. § 285
2 and for an award of attorneys' fees and costs in this action;

3 8. For damages resulting from Defendants' breach of the Agreement
4 (Exhibit D hereto), as well as all applicable injunctive relief related thereto;

5 9. For an assessment of prejudgment interest; and

6 10. For such other and further relief as the Court may deem just and proper
7 under the circumstances.

8 Dated: February 13, 2013

By: _____
 Reynaldo C. Barceló (199741)

9
10 BARCELÓ, HARRISON & WALKER, LLP
11 2901 West Coast Hwy, Suite 200
12 Newport Beach, CA 92663
13 (949) 340-9736

14 *Attorneys for Plaintiff, TMI Products, Inc.*

15
16 **DEMAND FOR JURY TRIAL**

17 TMI Products, Inc. hereby demands a jury trial pursuant to Rule 38 of the
18 Federal Rules of Civil Procedure as to all issues in this lawsuit.

19
20 Dated: February 13, 2013

By: _____
 Reynaldo C. Barceló (199741)

21
22 BARCELÓ, HARRISON & WALKER, LLP
23 2901 West Coast Hwy, Suite 200
24 Newport Beach, CA 92663
25 (949) 340-9736

26 *Attorneys for Plaintiff, TMI Products, Inc.*

EXHIBIT A



US007040697B1

(12) **United States Patent**
Tuccinardi et al.

(10) **Patent No.:** **US 7,040,697 B1**
(45) **Date of Patent:** **May 9, 2006**

(54) **HEADREST HAVING AN INTEGRATED VIDEO SCREEN**

5,267,775 A	12/1993	Nguyen	
5,292,174 A	3/1994	Ohnuma	
5,293,244 A *	3/1994	Kawaguchi	348/789
5,311,302 A	5/1994	Berry et al.	
5,333,416 A	8/1994	Harris et al.	
5,359,349 A	10/1994	Jambor et al.	
5,507,556 A *	4/1996	Dixon	297/217.3
5,529,265 A	6/1996	Sakurai	
5,555,466 A	9/1996	Scribner et al.	
5,640,297 A	6/1997	Labaze	
5,713,633 A	2/1998	Lu	

(75) Inventors: **Eugene M. Tuccinardi**, Temecula, CA (US); **Ernesto R. Haack**, Perris, CA (US); **Robert Murphy**, Lake Elsinore, CA (US); **Frank Barrese**, Temecula, CA (US); **Roel C. Espina**, Loma Linda, CA (US); **Jon A. Molo**, Ontario, CA (US); **Theo Zoetemelk**, Riverside, CA (US)

(73) Assignee: **Timely Innovations, LP**, Temecula, CA (US)

(*) Notice: Subject to any disclaimer, the term of this patent is extended or adjusted under 35 U.S.C. 154(b) by 0 days.

(21) Appl. No.: **10/395,870**

(22) Filed: **Mar. 20, 2003**

(51) **Int. Cl.**
A47C 31/00 (2006.01)
A47C 7/62 (2006.01)

(52) **U.S. Cl.** **297/217.3; 297/188.04**

(58) **Field of Classification Search** **297/217.3, 297/188.04, 188.07, 185; 411/510; 312/242, 312/245**

See application file for complete search history.

(56) **References Cited**

U.S. PATENT DOCUMENTS

3,004,815 A *	10/1961	O'Kain et al.	312/242
4,584,603 A	4/1986	Harrison	
4,635,110 A	1/1987	Weinblatt	
4,647,980 A	3/1987	Steventon et al.	
4,756,528 A	7/1988	Umashankar	
4,776,739 A *	10/1988	Hamman	411/510
4,788,588 A	11/1988	Tomita	
4,866,515 A	9/1989	Tagawa et al.	
RE33,423 E *	11/1990	Lobanoff	297/188.06
4,983,951 A	1/1991	Igarashi et al.	

(Continued)

FOREIGN PATENT DOCUMENTS

DE 3637772 A1 * 5/1988

(Continued)

Primary Examiner—Peter M. Cuomo

Assistant Examiner—Sarah B. McPartlin

(74) *Attorney, Agent, or Firm*—Knobbe, Martens, Olson & Bear, LLP

(57) **ABSTRACT**

A seat back video display assembly adapted to be positioned in the back of a vehicle seat having an outer skin cover. In one aspect, the assembly may comprise a receptacle member having sidewalls and a back wall so as to define an opening wherein the receptacle member is adapted to be positioned in the back of the vehicle seat. In addition, the assembly may further comprise a carrier member having sidewalls and a back wall so as to define an opening, wherein the carrier member includes at least one fastener that extends from the back wall of the carrier member and engages with the back wall of the receptacle member to secure the carrier member into the receptacle member. Moreover, the assembly may still further comprise a video display unit that is sized so as to be positioned secured within the opening in the carrier member, wherein the video display unit provides video signals.

24 Claims, 10 Drawing Sheets

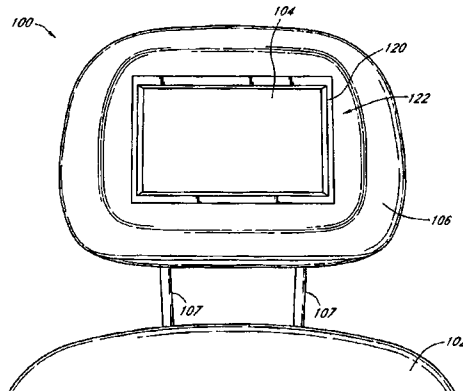

US 7,040,697 B1

Page 2

U.S. PATENT DOCUMENTS				FOREIGN PATENT DOCUMENTS			
				6,669,285	B1 *	12/2003	Park et al. 297/217.3
				6,739,654	B1 *	5/2004	Shen et al. 297/188.04
				6,750,599	B1 *	6/2004	Tajima 313/292
				6,755,491	B1 *	6/2004	McElheney 312/242
D398,921	S	9/1998	Rosen	2001/0008266	A1	7/2001	Lambert
5,842,715	A	12/1998	Jones	2003/0025367	A1	2/2003	Boudinot
6,024,027	A *	2/2000	Esmaili 109/50	2004/0007906	A1 *	1/2004	Park et al. 297/217.3
D434,400	S	11/2000	Rosen	2004/0160096	A1 *	8/2004	Boudinot 297/217.3
6,199,948	B1	3/2001	Bush et al.				
6,216,927	B1	4/2001	Meritt				
6,250,967	B1	6/2001	Chu				
6,292,236	B1	9/2001	Rosen				
6,339,455	B1	1/2002	Allan et al.				
6,394,551	B1	5/2002	Beukema	FR	2764563	A1	12/1998
6,406,334	B1	6/2002	Chu	JP	01094048	A	4/1989
6,409,242	B1	6/2002	Chang				
6,480,243	B1 *	11/2002	Yamamoto 348/836				

* cited by examiner

U.S. Patent

May 9, 2006

Sheet 1 of 10

US 7,040,697 B1

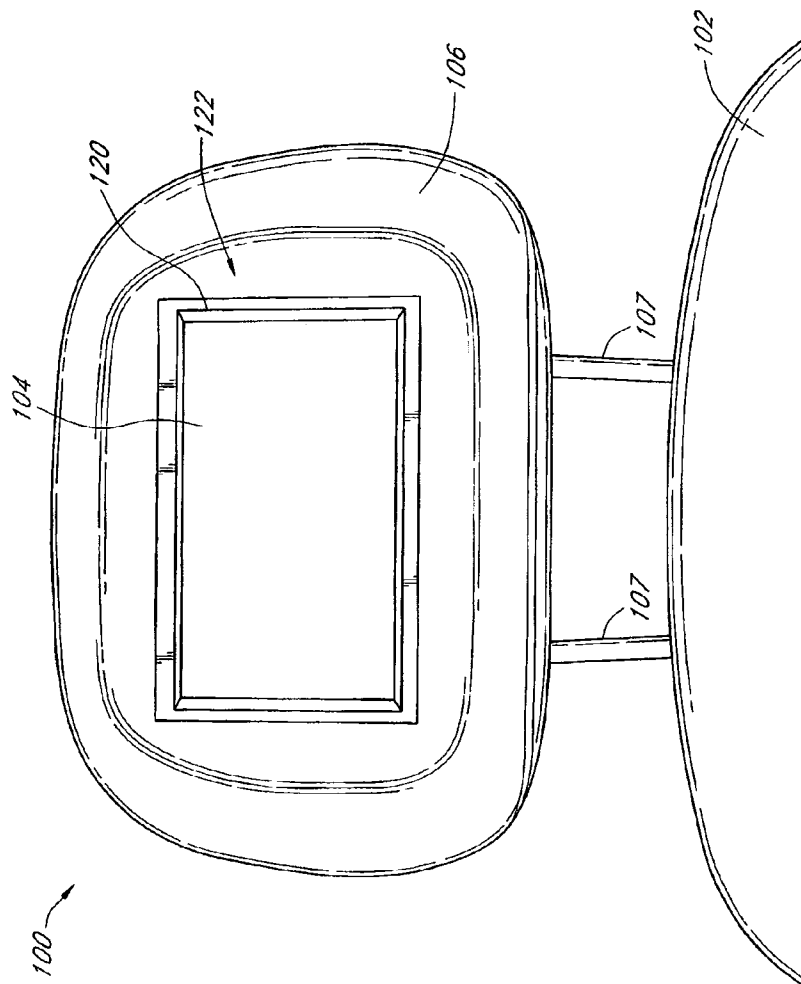

FIG. 1A

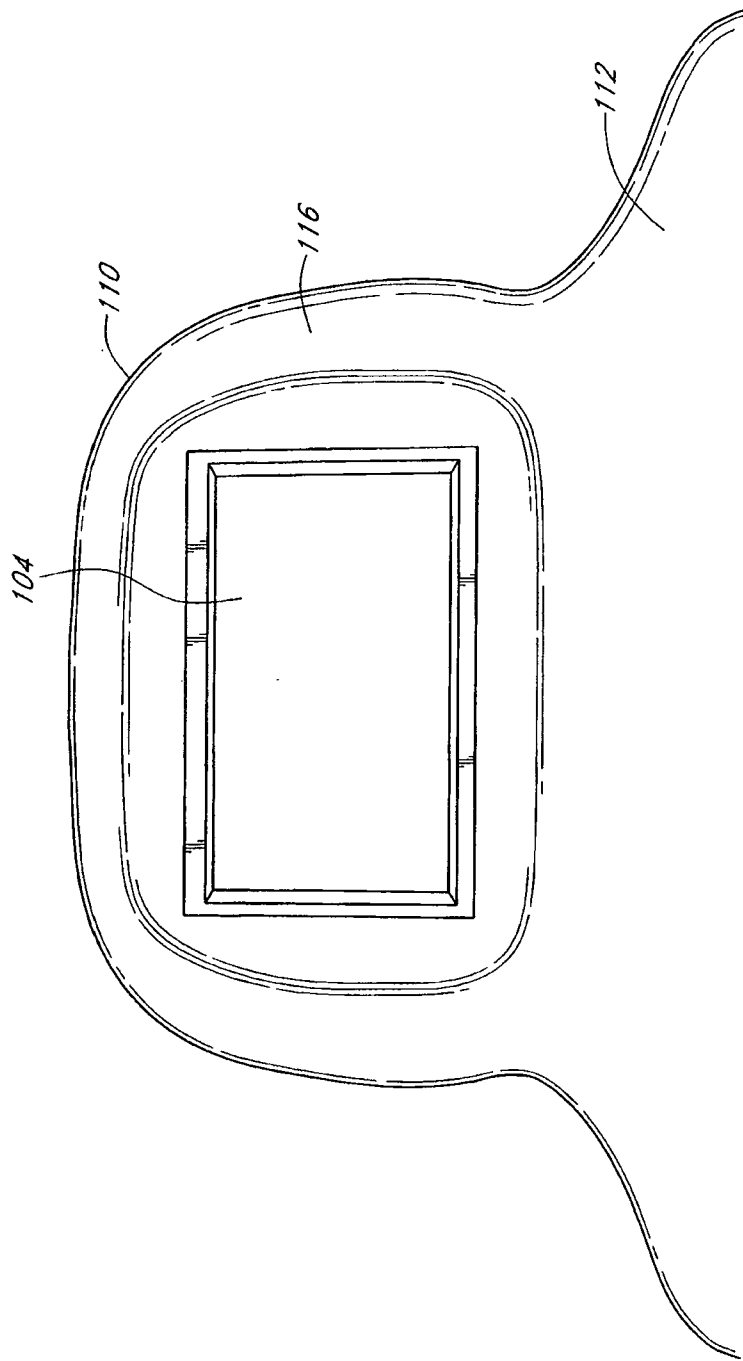

FIG. 1B

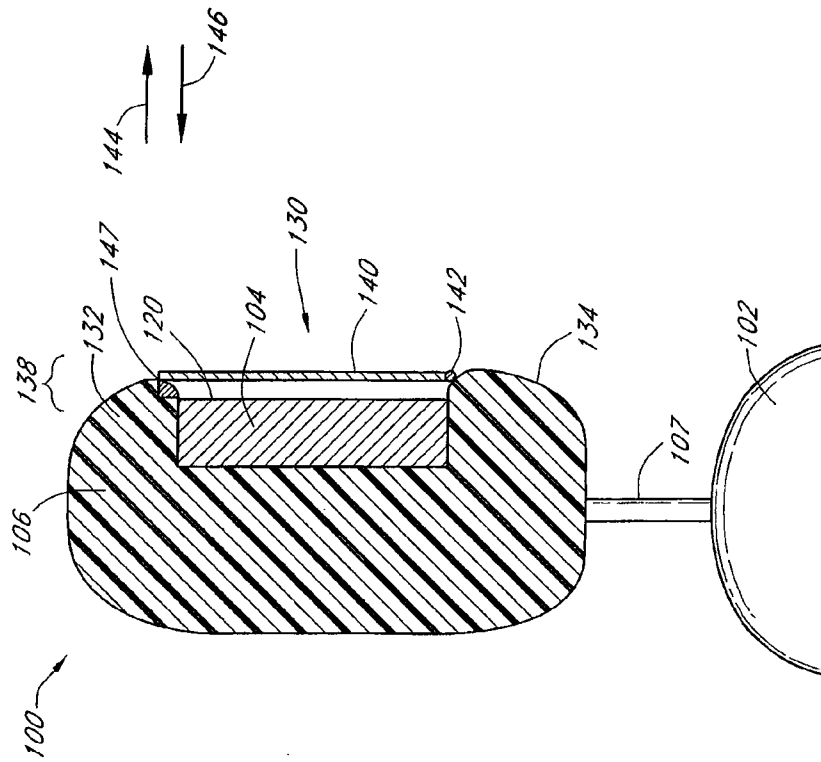

FIG. 3A

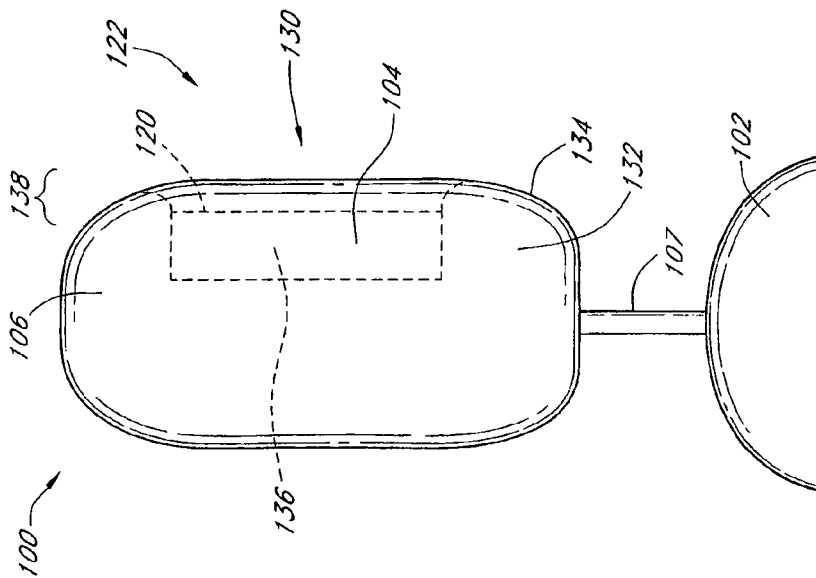

FIG. 2

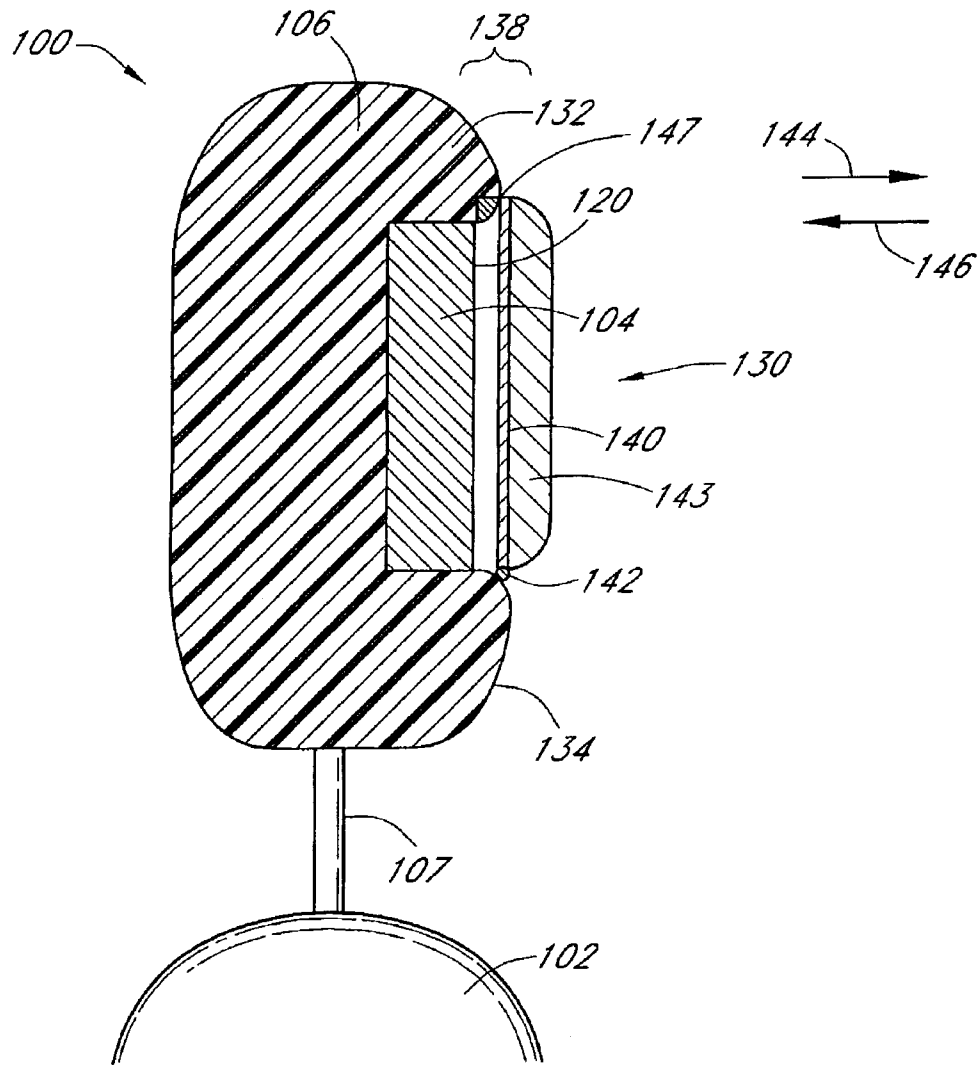

FIG. 3B

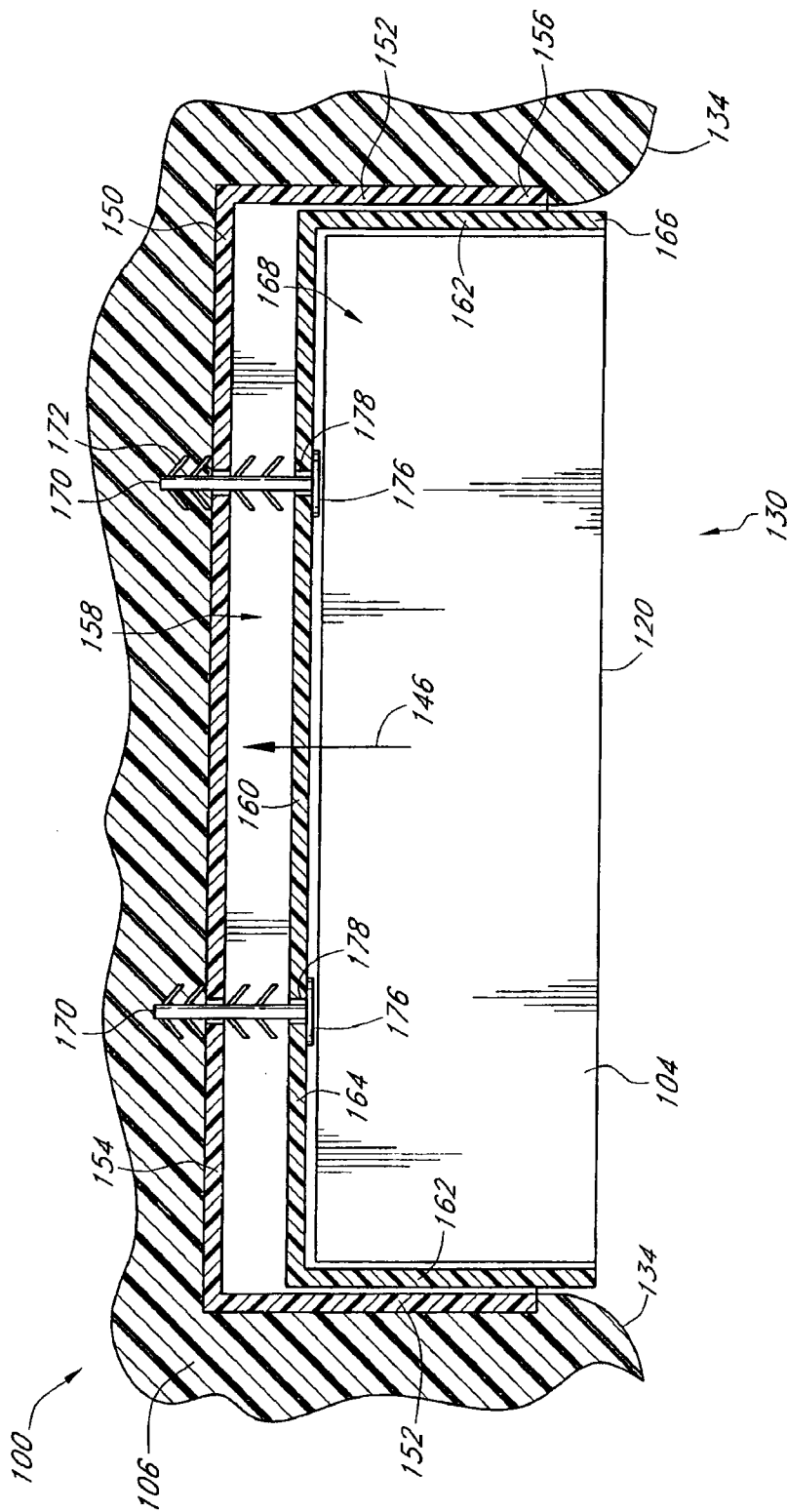

FIG. 4

U.S. Patent

May 9, 2006

Sheet 6 of 10

US 7,040,697 B1

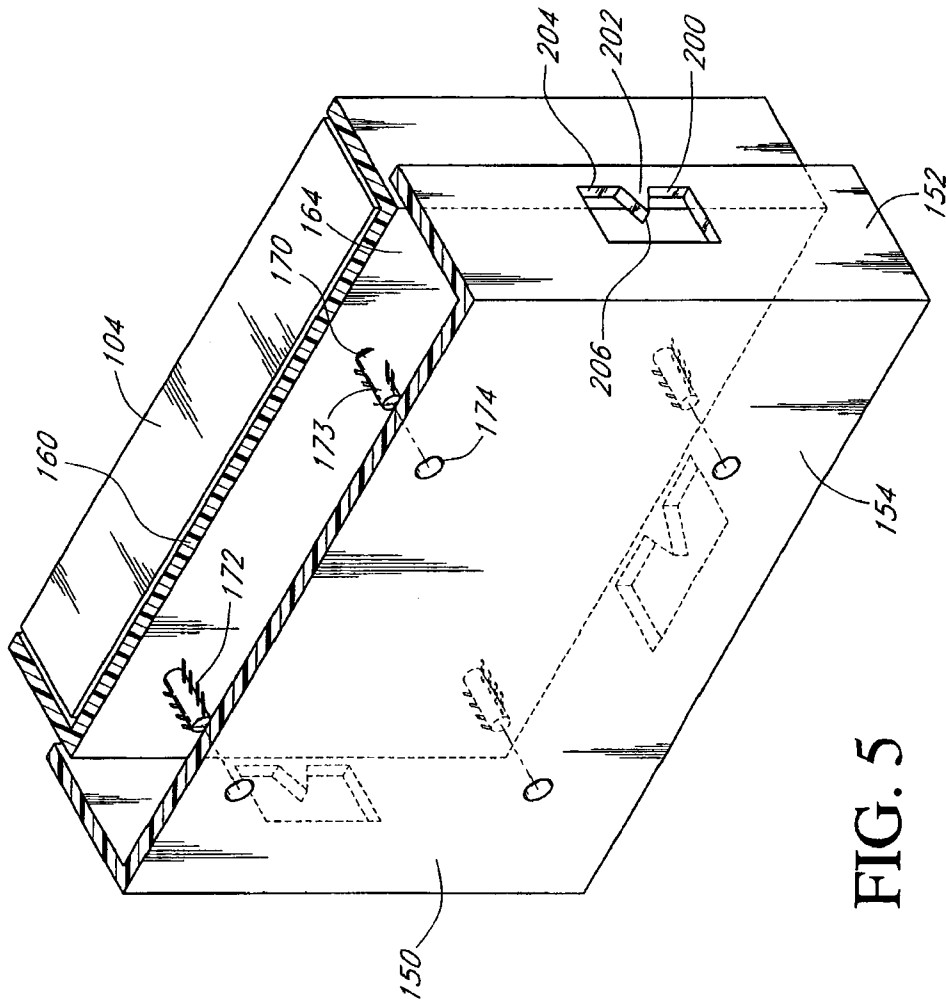

FIG. 5

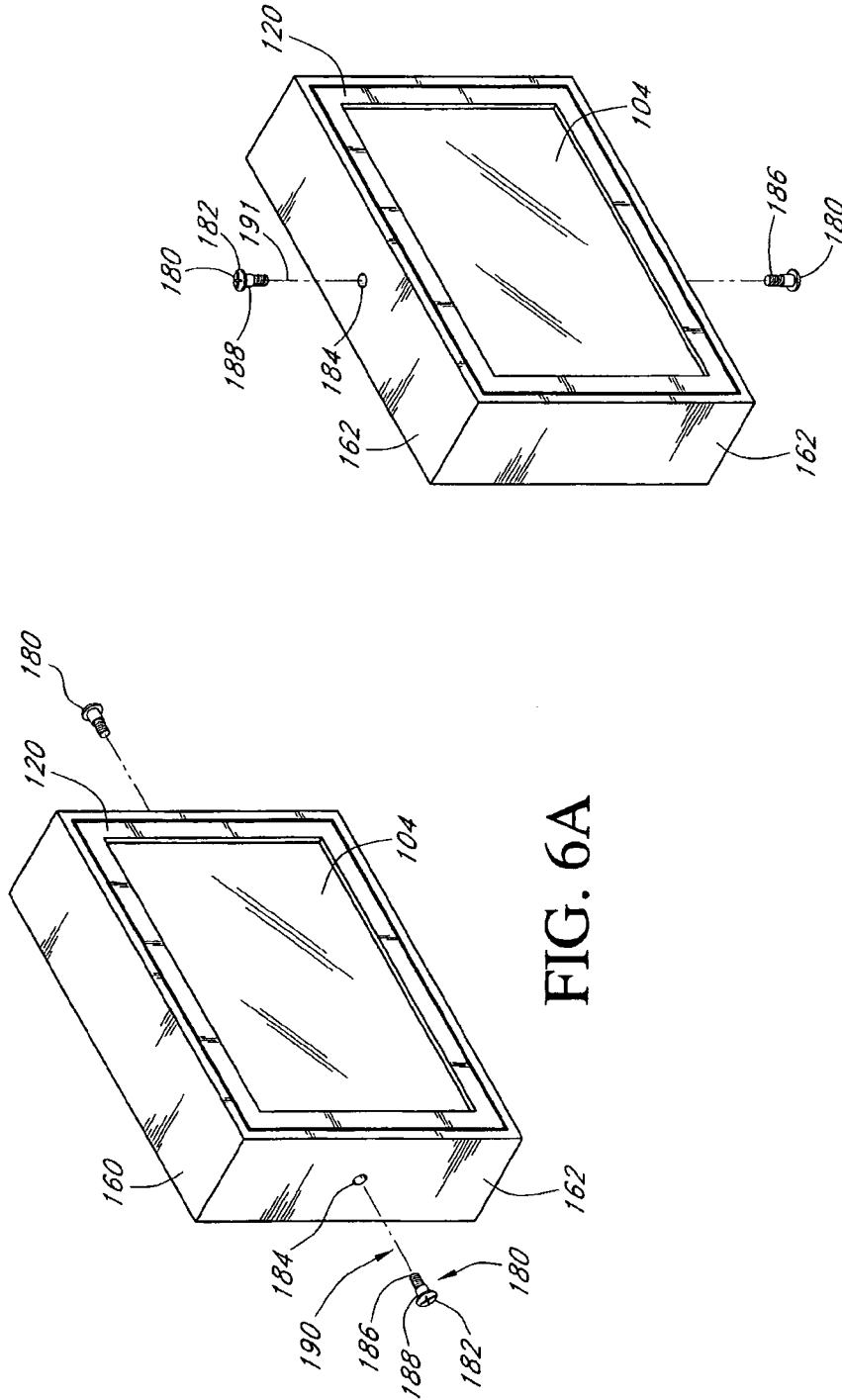

FIG. 6B

FIG. 6A

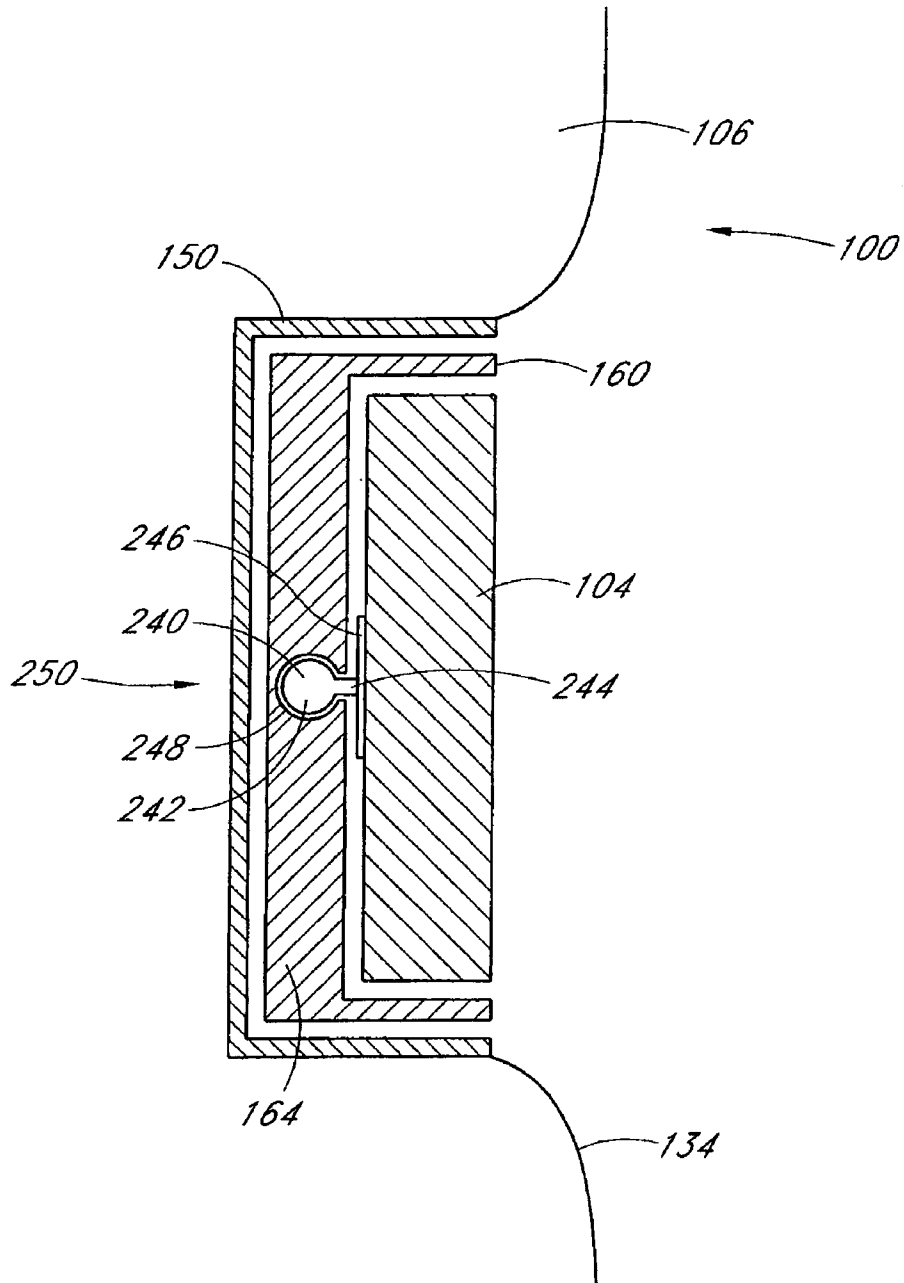

FIG. 6C

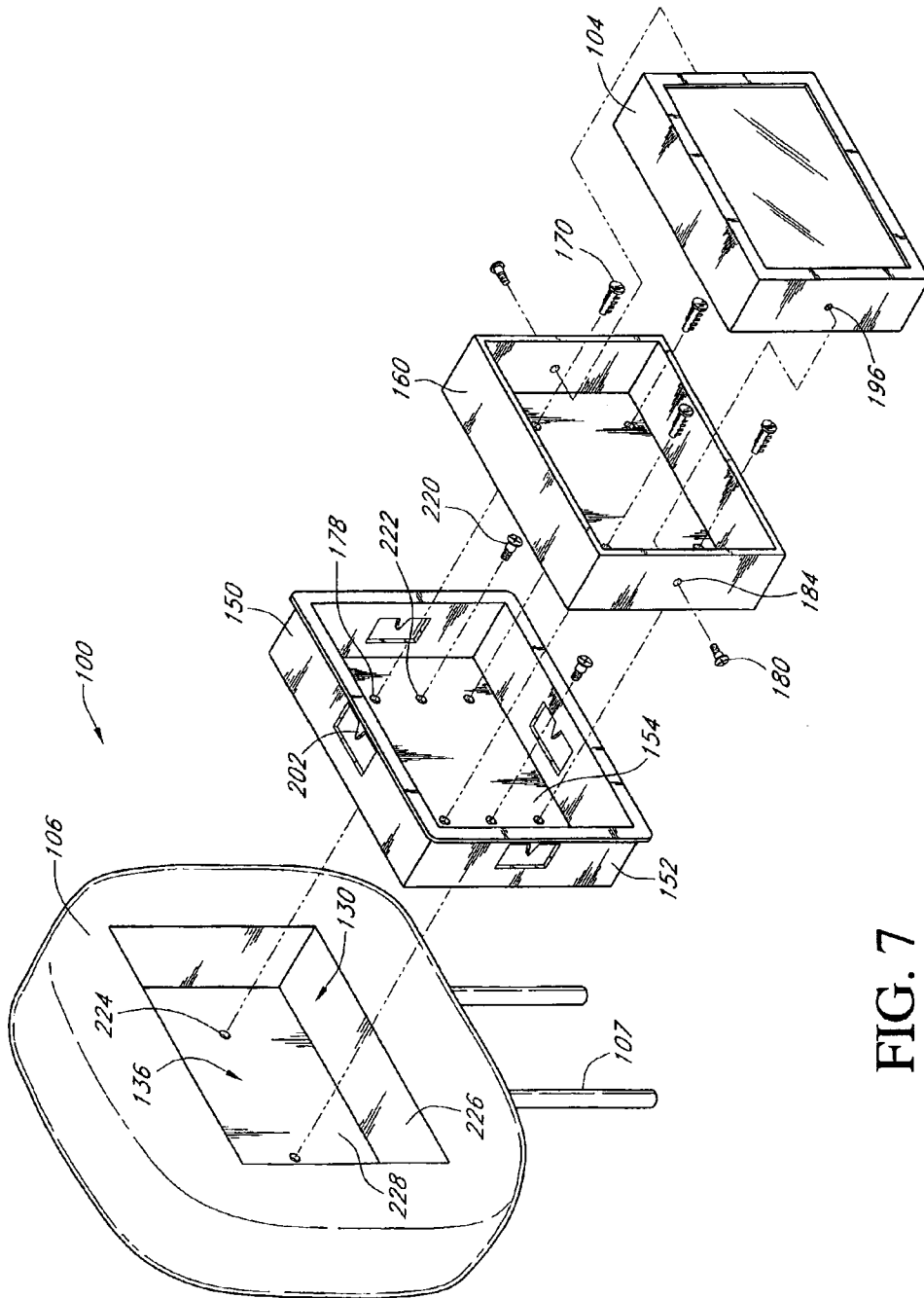

FIG. 7

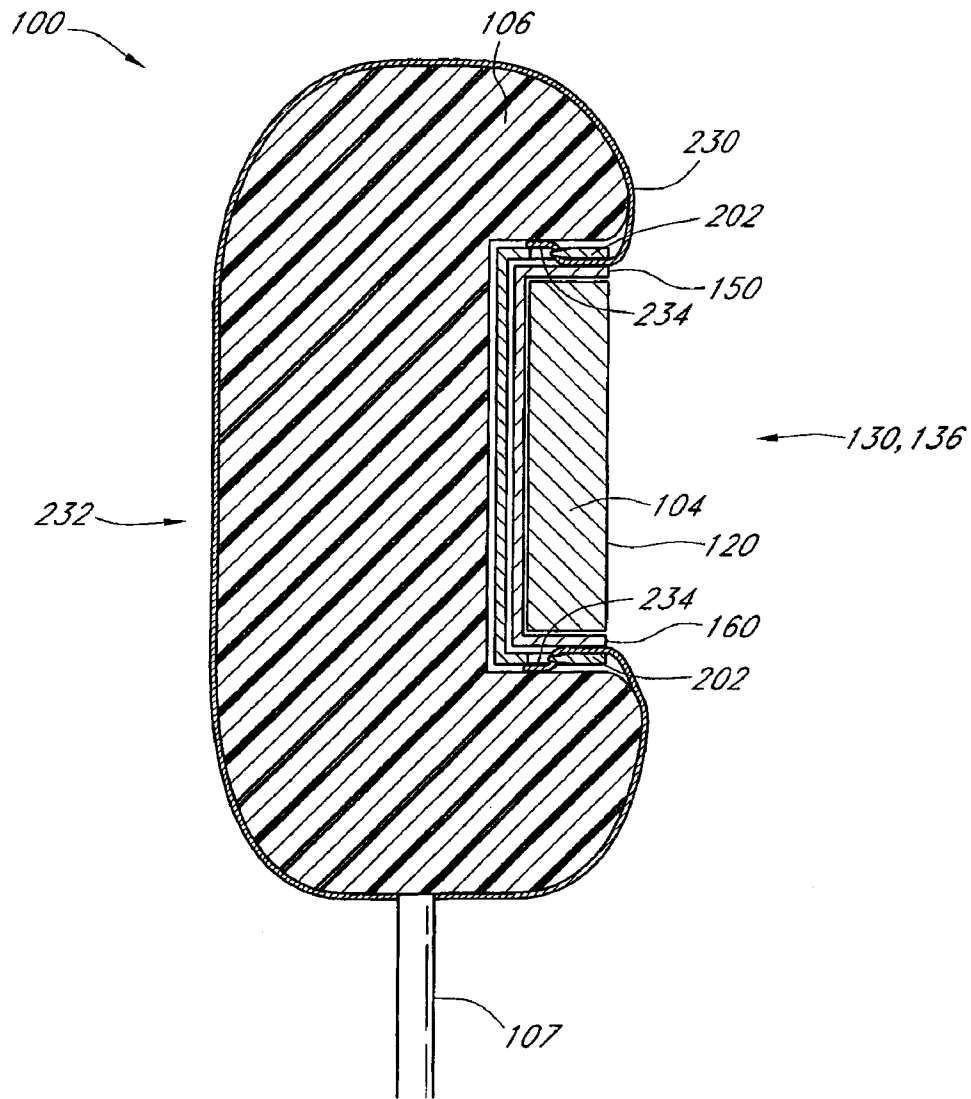

FIG. 8

US 7,040,697 B1

1

HEADREST HAVING AN INTEGRATED VIDEO SCREEN

BACKGROUND OF THE INVENTION

1. Field of the Invention

The present invention relates to motor vehicles and, in particular, to a headrest for motor vehicle seats having an integrated video screen mounted therein.

2. Description of the Related Art

Seat back video monitors are becoming increasingly popular in vehicles. Originally, these entertainment systems were largely confined to airplanes, however, recently, these systems have become much more popular with cars, trucks and SUVs. These entertainment systems provide the opportunity for passengers to view entertainment or educational video programs during long trips.

Typically, these systems have been installed as aftermarket products where the seat back is modified to accept the video display device, however, more of these systems are being installed as original equipment. Unfortunately, existing systems are often difficult and labor intensive to mount, particularly as an aftermarket product and are also subject to being dislodged.

Generally, the devices are mounted on the outer surface of the seat back where they protrude. In many vehicles, the space between seats and seat backs is limited, hence the protruding video display unit can inhibit the ability of passengers to easily get into and out of the vehicles. Moreover, passenger contact with the protruding video display screen may result in the screens being inadvertently dislodged.

A further difficulty with many existing video display unit designs is that they are not well secured to the seat. This is particularly the case for designs that allow the video display unit to pivot about an axis to improve the viewing angle of the passenger. One common way that these display units are installed is that a bucket is installed into the seat and the peripheral rim of the bucket includes openings that receive pivot posts that extend outward from the housing of the display unit. The pivot posts are positioned within the openings and keepers or caps are then positioned in the openings to prevent the pivot posts from being removed from the openings.

In these designs, the keepers or caps are generally press fit and are exposed to the passenger. Hence, inadvertent contact may result in the keepers or caps being dislodged. Moreover, many of the passengers are children who, through boredom, may attempt to remove the keepers which can result in the video display being dislodged and potentially damaged.

Hence, from the foregoing, there is a need for a seat back video display system and method of mounting that provides more secure mounting of the video display unit. To this end, there is a need for an assembly that is less likely to be dislodged through inadvertent contact and does not have exposed detachable mounting components.

SUMMARY OF THE INVENTION

The aforementioned needs may be satisfied by a seat back video display assembly adapted to be positioned in the back of a vehicle seat having an outer skin cover. In one aspect, the assembly may comprise a receptacle member having sidewalls and a back wall so as to define an opening, wherein the receptacle member is adapted to be positioned in the back of the vehicle seat. In addition the assembly may

2

further comprise a carrier member having sidewalls and a back wall so as to define an opening, wherein the carrier member includes at least one fastener that extends from the back wall of the carrier member and engages with the back wall of the receptacle member to secure the carrier member into the receptacle member, and a video display unit that is sized so as to be positioned secured within the opening in the carrier member, wherein the video display unit provides video signals.

Additionally, in one embodiment, the at least one fastener may comprise a plurality of fasteners that include a central member that extends outward from back wall of the carrier member and a plurality of flexible engagement members attached to the central member, wherein the flexible engagement members are deformable so as to allow insertion of the central member into the openings in the back wall of the receptacle member, and wherein the flexible engagement members are biased outward so as to inhibit removal of the central member from the openings in the back wall of the receptacle member. Also, the video display unit may be pivotally attached to the carrier member such that the plane of the video display unit can be adjusted by a user about a pivot point or axis, wherein the video display unit may be pivotable about a substantially horizontal pivot axis, a substantially vertical pivot axis, or pivot point that allows a continuous range of pivotal motion about the pivot point. Also, the openings may be positioned in the sidewalls of the receptacle member and the plurality of capture members are positioned within the openings, and wherein the plurality of capture members define a pointed surface that engages with the outer skin and inhibits removal of the outer skin from the opening defined by the receptacle member so as to securely fasten the outer skin to the receptacle member.

Additionally, in certain embodiments, the seat back video display assembly includes a screen cover that is dimensioned to cover the video display unit such that the screen cover can disengageably cover the screen of the video display unit to occlude the screen. The screen cover can include an impact attenuating material, a rigid protective layer, or any combination thereof.

The aforementioned needs may also be satisfied by a vehicle seat assembly having a seat back display. In one aspect, the vehicle seat assembly may comprise a vehicle seat adapted to receive an occupant during travel of a vehicle, the vehicle seat defining a seat back with an outer contour and a skin, and a receptacle member having sidewalls and a back wall to as to define an opening, wherein the receptacle member is mounted in the seat back of the vehicle seat such that the sidewalls are located at or below the outer contour of the seat back. In addition, the vehicle seat assembly may further comprise a video display unit mounted within the receptacle member, wherein the video display unit is generally planar with the outer plane being mounted at or below the outer contour of the seat back.

Moreover, the aforementioned needs may also be satisfied by a method of installing a video display unit into a seat back of a vehicle seat. In one embodiment, the method may comprise cutting an opening through an outer skin of the seat back, forming an aperture in the seat back, and positioning a receptacle in the aperture such that the receptacle is mounted at or below the level of the seat back. In addition, the method may comprise securing the video display unit to a carrier, and mounting the carrier into the receptacle such that an upper surface of the video display unit is mounted below the outer surface of the seat back. These and other objects and advantages of the present invention will become

US 7,040,697 B1

3

more fully apparent from the following description taken in conjunction with the accompanying drawings.

BRIEF DESCRIPTION OF THE DRAWINGS

FIG. 1A illustrates an adjustable headrest for a motor vehicle seat having an integrated video screen mounted therein.

FIG. 1B illustrates a fixed headrest for a motor vehicle seat having the integrated video screen of FIG. 1A mounted therein.

FIG. 2 illustrates a side view of the adjustable headrest shown in FIG. 1A having the integrated video screen mounted therein with a recessed orientation.

FIGS. 3A, 3B illustrate a cross-sectional view of the adjustable headrest shown in FIG. 1A having the integrated video screen mounted therein with a screen cover.

FIG. 4 illustrates a cross-sectional view of the integrated video screen being mounted to the headrest via a carrier receptacle, a carrier member, and a plurality of fasteners.

FIG. 5 illustrates a perspective view of the integrated video screen being mounted to the headrest via the carrier member and the plurality of fasteners of FIG. 4.

FIGS. 6A, 6B illustrate a perspective view of mounting the integrated video screen to the carrier member.

FIG. 6C illustrates a side view of mounting the integrated video screen to the carrier member via pivot member.

FIG. 7 illustrates a perspective view of mounting the integrated video screen to the adjustable headrest of FIG. 1A.

FIG. 8 illustrates a cross-sectional view of the video screen mounted to the headrest, wherein an outer skin from the headrest is secured to the carrier receptacle.

DETAILED DESCRIPTION OF THE PREFERRED EMBODIMENT

Reference will now be made to the drawings wherein like numerals refer to like parts throughout. A headrest for motor vehicle seats having an integrated video screen mounted therein in a flush or recessed manner will be described in greater detail herein below with reference to the drawings. In one aspect, it should be appreciated that the term motor vehicle seats refers to a plurality of generally known motor vehicles seats, such as those manufactured for automobiles, buses, boats, cars, semi-trucks, etc., wherein the following discussion can be similarly applied to these various types of motor vehicle seats without departing from scope of the present teachings. In addition, the following discussion refers to mounting the integrated video screen to the headrest of motor vehicle seats but may also be applied to other various component features of motor vehicle seats, such as the seat back, without departing from the scope of the present teachings.

FIG. 1A illustrates an adjustable headrest 100 for a first motor vehicle seat 102 having an integrated video screen 104 mounted therein. As illustrated in FIG. 1A, the adjustable headrest 100 is coupled to the seat 102 via posts 106 that extend therefrom and allow vertical adjustment of the adjustable headrest 100 with respect to the seat 102 in a generally known manner. FIG. 1B illustrates a fixed headrest 110 for a second motor vehicle seat 112 having the integrated video screen 104 mounted therein. In one embodiment, the video screen 104 is mounted within a headrest bun 106, 116 that is adapted to receive the video screen 104 for firm attachment therein in a manner that will be described in greater detail herein below. In addition, as will be described

4

in greater detail herein below, the video screen 102 is mounted such that a front surface 120 of the video screen 104 is either flush or recessed from a contour 122 of the headrest 100, 110.

In one embodiment, the video screen 104 comprises a generally known LCD (liquid crystal display) monitor or terminal that can be electrically coupled to a video entertainment system so as to receive video signals therefrom for viewing of movies, television, internet web pages, video games, etc. As illustrated, the video screen 104 is generally rectangular in shape with the planar front surface 120 that is viewable by a user. In one aspect, it should be appreciated that the degree of recessed depth (with no depth comprising a flush mount) of the integrated video screen 104 and the manner in which the contour 122 of the seat 102, 112 is shaped may be selected such that the shape (side view, for example) of the headrest 100, 110 with the integrated video screen 104 mounted therein is generally similar to the shape of the headrest 100, 110 without the integrated video screen 104. Moreover, it should be appreciated that the motor vehicle seats 102, 112 may comprise any one of a number of various types or models of generally known motor vehicle seats without departing from the scope of the present invention.

FIG. 2 illustrates a side view of the adjustable headrest 100 shown in FIG. 1A having the integrated video screen 104 mounted therein with a recessed orientation. It should be appreciated that the following discussion is with respect to the adjustable headrest 100 of FIG. 1A but may be similarly applied to the fixed headrest 110 of FIG. 1B without departing from the scope of the present teachings.

FIG. 2 further illustrates the side view shape or contour 122 of the headrest 100. As illustrated in FIG. 2, the contour 122 of the headrest 100 is maintained due to the recessed orientation of the video screen 104 within the headrest bun 106. In addition, an opening 130 is formed in a rear section 132 of the headrest 100 so as to define a substantially rectangular interior region 136 within the headrest bun 106 below an outer surface 134 of the headrest 100. As further illustrated in FIG. 2, the video screen 104 can then be positioned adjacent the opening 130 so as to be firmly positioned within the interior region 136 of the headrest bun 106. Moreover, the recessed orientation may be defined by a depth 138 between the front surface 120 of the video screen 104 and the outer surface 134 of the headrest 100. The depth 138 therebetween may vary in magnitude depending on the thickness of the headrest bun 106 and/or the internal structural characteristics of the headrest 100, which may vary with respect to the type or model of motor vehicle seat used. In one aspect, the depth 138 of the recessed orientation may comprise a magnitude of approximately zero so as to define a flush mounted video screen 104, wherein the front surface 1120 of the video screen 104 is substantially aligned with the outer surface 134 of the headrest 100.

FIG. 3A illustrates a cross-sectional view of the adjustable headrest 102 shown in FIGS. 1A having the integrated video screen 104 mounted therein with the recessed orientation shown in FIG. 2 and a screen cover 140. In one embodiment, the screen cover 140 is coupled to the rear section 132 of the headrest 100 via a hinge 142 so as to overlie the video screen 104 and at least part of the opening 130 formed therein. The screen cover 140 may comprise generally rectangular shape and is oriented generally parallel to the front surface 120 of the video screen 104 so as to temporarily occlude the video screen 104. In one aspect, as further illustrated in FIG. 3A, the screen cover 140 can be positioned adjacent the opening

US 7,040,697 B1

5

130 so as to substantially align with the outer surface 134 of the headrest 100 thus forming a flush mounting therewith. It should be appreciated that the screen cover 140 may be positioned within the opening 130 so as to be recessed with respect to the outer surface 134 of the headrest 100 without departing from the scope of the present teachings. Moreover, the screen cover 140 may comprise a rigid material, such as plastic, metal, etc. Alternatively, in another aspect, the screen cover 140 may comprise a piece or flap of material that is attached to the headrest 100 adjacent the lower side of the video screen 104.

In still another aspect, as illustrated in FIG. 3B, the screen cover 140 may comprise an impact attenuating section 143 comprising a material such as foam, various types of padding, an air cushion, etc. so as to soften the force of an impact from an object. For example, during a car accident, a person's head may be propelled towards the screen cover 140, wherein the impact attenuating material may soften the impact to the headrest 102 to thereby protect the person's head and the video screen 104 from damage.

Also, in one embodiment, the video screen 104 can be viewed by opening the screen cover 140 or temporarily occluded by closing the screen cover 140. Hence, the screen cover 140 can be outwardly rotated about the hinge 142 in a first direction 144 to openly view the video screen 104, or the screen cover 140 can be inwardly rotated about the hinge 142 in a second direction 144 opposite the first direction 144 to temporarily occlude the video screen 104. Advantageously, the screen cover 104, when closed, conceals the video screen 104 from view thus, in some situations, functions as a thief deterrent.

Moreover, in one aspect, the recessed configuration of the video screen 104 facilitates the manner in which the screen cover 140 may be deployed. For example, the video screen 104 may not physically interfere with the closing of the screen cover 140. In addition, as illustrated in FIGS. 3A, 3B, the screen cover 140 is intended to "hide" the video screen 104 from outside observers, thereby reducing the probability that the video screen 104 will be a target of theft. As further illustrated in FIGS. 3A, 3B, the screen cover 140 may further comprise a means for engagement 144 that allows the screen cover 140 to remain in the "up" or closed configuration. In general, it should be appreciated that some possible means for achieving such an engagement include but are not limited to magnetic strips, mechanical clips, velcro strips, and the like.

FIG. 4 illustrates a cross-sectional view of the integrated video screen 104 being mounted to the headrest 100 via a carrier receptacle 150, a carrier member 160, and first fasteners 170. FIG. 5 illustrates a perspective view of the integrated video screen 104 being mounted to the headrest 100 via the carrier receptacle 150, the carrier member 152, and the first fasteners 170. In one embodiment, the carrier receptacle 150 comprises a plurality of planar sidewalls 152 and a rear planar wall 154 that are joined together in a manner so as to form a substantially rectangular outer structure 156 having an inner recessed region 158 that is adapted to receive the carrier member 152 therein. Similarly, the carrier member 152 comprises a plurality of planar sidewalls 162 and a rear planar wall 164 that are joined together in a manner so as to form a substantially rectangular outer structure 166 having an inner recessed region 168 that is adapted to receive the video screen 104 therein.

As illustrated in FIG. 4, the video screen 104 may be mounted within the carrier member 160 via side fasteners 180 (shown in FIGS. 6A, 6B) and then the carrier member

6

152 is mounted within the carrier receptacle 150 via the first fasteners 170 so as to simplify the mounting of the video screen 104 to the headrest 100 including the headrest bun 106. In one aspect, the first fasteners 170 may comprise a plurality of flexible engagement members 172 that extend therefrom so as to mechanically couple with a plurality of mounting apertures 174 (FIG. 5) formed in the rear wall 154 of the carrier receptacle 150. The first fasteners 170 may further comprise a central member 173 that extends outward from the rear wall 164 of the carrier member 160. Also, the flexible engagement members 172 are attached to the central member 173, wherein the flexible engagement members 172 are deformable so as to allow insertion of the central member 173 into the mounting apertures 174 in the rear wall 164 of the receptacle member 150. Moreover, the flexible engagement members 170 are biased outward so as to inhibit removal of the central member 173 from the mounting apertures 174 in the rear wall 154 of the receptacle member 150. In addition, the first fasteners 170 comprise a head 176 that abuts the rear wall 164 of the carrier member 152 and is positioned through a plurality of second apertures 178 formed in the rear wall 164 of the carrier member 152.

Advantageously, the video screen 104 can be mounted to the headrest 100 via the carrier receptacle 150 and the carrier member 152 without using external fasteners that may be seen. Hence, the video screen 104 can be mounted to the headrest 100 in a more aesthetically appealing manner, wherein the front surface 120 of the video screen 104 recessed or flush mounted with respect to the outer surface 134 of the headrest 100, and wherein the first and second fasteners 170, 180 are concealed from view.

As illustrated in FIG. 5, the sidewalls 152 of the carrier receptacle 150 each comprise at least one sidewall aperture 200 having at least one serrated tooth 202 protruding from an interior sidewall 204. In one embodiment, the at least one serrated tooth 202 is triangular in shape having a pointed tip 206 that projects outward from the interior sidewall 204 in a horizontal manner. It should be appreciated that the serrated tooth 202 may comprise any one of a number of various shapes known in the art without departing from the scope of the present teachings. Additionally, as will be shown in FIG. 8, the pointed tip 234 engages with the outer skin 230 (FIG. 8) and inhibits removal of the outer skin 230 from the at least one sidewall aperture 200 formed in the carrier receptacle 150. Advantageously, as will be described in greater detail herein below, the serrated tooth 200 allows outer skin from the motor vehicle seat 102, 112 to be attached to the carrier receptacle 150 by wrapping the outer skin around the planar sidewalls 152 and into the recessed region 158 of the carrier receptacle 150 and then securing the outer skin to the serrated tooth 200.

FIG. 6A illustrates a perspective view of attaching the integrated video screen 104 to the carrier member 152 via the second fasteners 180. In one embodiment, the planar sidewalls 162 of the carrier member 160 comprise pivot apertures 184 that allow the video display 104 to be mounted to the carrier member 160. Also, the pivot apertures 184 are adapted to rotatably receive the second fasteners 180. As illustrated in FIG. 6A, the second fasteners 180 comprise a threaded region 186 that mechanically couples to threaded apertures 196 (FIG. 7) formed in the video screen 104 in a generally known manner so as to be securely attached thereto. Moreover, the second fasteners 180 further comprise a head 182 and a smooth pivot region 188 interposed between the threaded region and the head 182.

In one aspect, the pivot region 188 of the second fastener 180 rotatably communicates with the pivot aperture 184 of

the carrier member 160 to thereby allow the video screen 104 to pivot or tilt with respect to the carrier member 160 and/or the headrest 100 along a horizontal pivot axis 190 defined by the horizontally mounted second fasteners 180. Hence, the video screen 104 is pivotally attached to the carrier member 160 such that the plane of the video screen 104 can be adjusted with respect to the headrest 100 by a user about the defined horizontal pivot axis 190. Advantageously, the horizontal pivot axis 190 allows the video screen 104 to readily pivot when mounted to the headrest 100 to thereby allow greater positional flexibility during viewing of the video screen 104 by a user.

FIG. 6B further illustrates a perspective view of attaching the integrated video screen 104 to the carrier member 152 via the second fasteners 180. In one embodiment, as illustrated in FIG. 6B, the second fasteners 180 can be mounted vertically through the planar sidewalls 162 of the carrier member 160. The pivot region 188 of the vertically mounted second fasteners 180 rotatably communicates with the pivot aperture 184 of the carrier member 160 to thereby allow the video screen 104 to pivot or tilt side-to-side with respect to the carrier member 160 and/or the headrest 100 along a vertical pivot axis 191 defined by the vertically mounted second fasteners 180. Hence, the video screen 104 is pivotally attached to the carrier member 160 such that the plane of the video screen 104 can be adjusted with respect to the headrest 100 by a user about the vertical pivot axis 191. Advantageously, the vertical pivot axis 191 allows the video screen 104 to readily pivot when mounted to the headrest 100 to thereby allow greater positional flexibility during viewing of the video screen 104 by a user.

In one aspect, it should be appreciated that the second fasteners 180 may comprise generally known screws, such as sheet metal screws, without departing from the scope of the present invention. It should also be appreciated that the pivot region 188 of the second fasteners 180 may be threaded in a manner such that the video screen 104 can still pivot with respect to the carrier member 150 without departing from the scope of the present invention.

FIG. 6C illustrates a view of attaching the integrated video screen 104 to the carrier member 152 via a pivot member 240. In one embodiment, as illustrated in FIG. 6C, the pivot member 240 comprises a spherical ball 242 attached to the video screen 104 via a shaft 244 and a plate 246. The spherical ball 242 is positioned within a spherical receptacle 248 formed in the rear wall 164 of the carrier member 160. As illustrated in FIG. 6C, the rear wall 164 of the carrier member 160 may be dimensioned so as to accommodate the spherical receptacle 248. In one aspect, the plate 246 of the pivot member 240 may be attached to the video screen 104 using an adhesive, such as epoxy or glue, or fasteners, such as screws or bolts. In addition, the shaft 244 distally extends from the plate 246 towards the spherical receptacle 248 of the carrier member 160. Also, the shaft 244 and the spherical ball 242 may be formed as an integral part of the plate 246 or may be formed separately and interconnected to the plate 246 via an adhesive or fasteners.

Moreover, once the pivot member 240 is attached to the video screen 104 in a manner as previously described, the spherical ball 242 of the pivot member 240 can be pressed to fit within the spherical receptacle 248 formed in the rear wall 164 of the carrier member 160. In one aspect, the spherical ball 242 may be sized at least less than the size of the spherical receptacle 248 so as to allow rotational movement therein. Advantageously, the resulting interconnection between the spherical ball 242 of the pivot member 240 and the spherical receptacle 248 of the carrier member 160

defines a pivot point 250 to thereby allow the video screen 104 to pivot, tilt, or rotate in a multi-directional manner with respect to the defined pivot point 250. Therefore, the defined pivot point 250 allows the video screen 104 to readily pivot when mounted to the headrest 100 to thereby allow greater positional flexibility during viewing of the video screen 104 by a user.

FIG. 7 illustrates a perspective view of mounting the integrated video screen 104 to the headrest 100 of FIG. 1A. In one embodiment, as illustrated in FIG. 7, the opening 130 is formed in the headrest bun 106 so as to define the substantially rectangular interior region 136 and to receive the carrier receptacle 150. The carrier receptacle 150 can then be positioned within the opening 130 so that the planar sidewalls 152 and the planar rear wall 154 abut the interior walls 226 of the mounting recess 136 formed in the headrest bun 106. In one embodiment, the carrier receptacle 150 can be secured to the headrest 100 via one or more third fasteners 220, such as screws, machine screws, sheet metal screws, etc. As illustrated in FIG. 7, the third fasteners 220 are positioned through rear wall apertures 222 formed in the rear wall 154 of the carrier receptacle 150 and coupled to rear mounting apertures 224 formed in a back wall 226 of the mounting recess 136 of the headrest bun 106. Advantageously, the third fasteners 220 can be securely attached to a structural component (not shown) of the headrest 100, such as an internal framework member of the headrest 100, so as to form a rigid attachment between the carrier receptacle 150 and the headrest 100.

In addition, the video screen 104 may be mounted to the carrier member 160 so as to pivot with respect thereto in a manner as previously described with reference to FIGS. 6A, 6B, 6C. Following, the carrier member 160 including the video screen 104 can then be mounted to the carrier receptacle 150 via the first fasteners 170 in a manner as previously described with reference to FIG. 4. Advantageously, this method of attaching the video screen 104 to the headrest 100 via the carrier receptacle 150, the carrier member 160, and the fasteners 170, 180 allows the video screen 104 to be securely mounted to the headrest 100 while providing a means for pivoting the video screen 104 with respect to the headrest 100 so as to improve the viewing range by a user.

FIG. 8 illustrates a cross-sectional view of the video screen 104 mounted to the headrest 100, wherein the outer skin 230 of the headrest 100 of the motor vehicle seat 102 is attached to the carrier receptacle 150 and the carrier member 160 with the video screen 104 mounted therein is mounted within the mounting recess 136 of the carrier receptacle 150. As is generally known, many motor vehicle car seats comprise the illustrated outer skin 230, such as fabric, leather, upholstery, vinyl, etc., that provides a outer surface 232 for a user to lean against or rest upon. In one aspect, when mounting the integrated video screen 104 into the headrest 100 of the motor vehicle seat 102, the outer skin 230 is adapted to accommodate the video screen 104 including the carrier receptacle 150. In some situations, one or more flaps 234 can be formed in the outer skin 230 and attached to the one or more serrated teeth 202 formed in the planar sidewalls 152 of the carrier receptacle 150.

As further illustrated in FIG. 8, the carrier receptacle 150 may be positioned within the mounting recess 136 formed in the headrest bun 106, and then the outer skin 230 is secured to the serrated teeth 202 via the flaps 234 formed therein by hooking the flaps 234 to one or more of the serrated teeth 202. Once the outer skin 230 is attached to the serrated teeth 202 via the flaps 234, the carrier member 160 is firmly pressed within the mounting recess 136 of the headrest bun

US 7,040,697 B1

9

106 so that the first fasteners 170 couple to the mounting apertures 174 formed in the rear wall 154 of the carrier receptacle 150.

Advantageously, this interconnection between the carrier member 160 and carrier receptacle 150 provides a quick and easy means for mounting of the video screen 104 to the headrest 100. In addition, the pressed fit of the outer skin between the carrier member 160 and the carrier receptacle 150 further secures the outer skin of the motor vehicle seat 102 to the carrier receptacle 150. As a result, the outer skin is securely held to the carrier receptacle 150 via the one or more serrated teeth 202 formed in the planar sidewalls 152 of the carrier receptacle 150 and the pressed fit of the carrier member 160 within the mourning recess 136 of the carrier receptacle 150.

Although the foregoing description has shown, described and pointed out the fundamental novel features of the invention, it will be understood that various omissions, substitutions, and changes in the form of the detail of the apparatus as illustrated, as well as the uses thereof, may be made by those skilled in the art, without departing from the spirit or scope of the present invention. Consequently, the scope of the invention should not be limited to the foregoing discussion, but should be defined by the appended claims.

What is claimed is:

1. A seat back video display assembly adapted to be positioned in a back of a vehicle seat having an outer skin, the assembly comprising:

a receptacle member having sidewalls and a back wall so as to define an opening wherein the receptacle member is adapted to be positioned in the back of the vehicle seat wherein the opening is facing away from the back of the vehicle seat when the receptacle member is positioned within the back of the vehicle seat and wherein the receptacle member includes at least one securing opening formed in the back wall of the receptacle member;

a carrier member having sidewalls and a back wall so as to define an opening, wherein the carrier member includes at least one fastener that is coupled to the back wall that extends from the back wall of the carrier member and engages with the at least one securing opening in the back wall of the receptacle member to secure the carrier member into the receptacle member and wherein the opening in the carrier member is facing away from the back of the vehicle seat when the carrier member is positioned within the receptacle member; and

a video display unit that is sized so as to be positioned secured within the opening in the carrier member and substantially conceal the at least one fastener, wherein the video display unit provides video signals wherein the video display unit is pre-assembled into the carrier member so that the combined video display unit and the carrier member can be simultaneously secured within the receptacle member by positioning the carrier member in the receptacle member such that the back wall of the carrier member is flush with the back wall of the receptacle member and the at least one fastener of the carrier member is pushed through the at least one securing opening.

2. The assembly of claim 1, wherein the receptacle member includes a plurality of openings positioned within the back wall that receive the fasteners of the carrier member.

3. The assembly of claim 2, wherein the at least one fastener comprises a plurality of fasteners that include a

10

central member that extends outward from back wall of the carrier member and a plurality of flexible engagement members attached to the central member, wherein the flexible engagement members are deformable so as to allow insertion of the central member into the openings in the back wall of the receptacle member, and wherein the flexible engagement members are biased outward so as to inhibit removal of the central member from the openings in the back wall of the receptacle member.

4. The assembly of claim 1, wherein the video display unit defines a plane and is pivotally attached to the carrier member such that the plane of the video display unit can be adjusted by a user about a pivot axis.

5. The assembly of claim 4, wherein the video display unit is pivotable about a substantially horizontal axis.

6. The assembly of claim 4, wherein at least a first and second fasteners are positioned through the carrier into the display unit so as to secure the video display unit to the carrier member prior to installation of the carrier into the receptacle member, and wherein the at least first and second fasteners engage with the video display unit so as to define a pivot axis.

7. The assembly of claim 1, wherein the receptacle member includes an outer lip and a plurality of outer skin capture members that engage with the outer skin of the seat back following installation such that the outer skin is extended over the outer lip of the receptacle member and secured to the outer skin capture members.

8. The assembly of claim 7, wherein openings are positioned in the sidewalls of the receptacle member and the plurality of capture members are positioned within the openings, and wherein the plurality of capture members define a pointed surface that engages with the outer skin and inhibits removal of the outer skin from the opening defined by the receptacle member.

9. The assembly of claim 1, further comprising a screen cover that is dimensioned to cover the video display unit in a first configuration following installation into the seat back, and wherein the cover is selectively disengagable so as to allow visual access to the video display unit.

10. The assembly of claim 9, wherein the cover includes an impact attenuating material.

11. The assembly of claim 9, wherein the cover includes a generally rigid layer to provide physical protection of the video display unit.

12. A vehicle seat assembly having a seat back display, the assembly comprising:

a vehicle seat adapted to receive an occupant during travel of a vehicle, the vehicle seat defining a seat back with an outer contour and an outer skin;

a receptacle member having sidewalls and a back wall so as to define an opening, wherein the receptacle member is mounted in the seat back of the vehicle seat such that the sidewalls are located at or below the outer contour of the seat back and wherein the receptacle member includes at least one opening in the side walls and at least one outer skin capture member having a pointed surface positioned within the at least one opening such that the at least one outer skin capture member captures the outer skin of the seat back to inhibit removal of the outer skin from the at least one opening; and

a video display unit mounted within the receptacle member, wherein the video display unit is generally planar with an outer plane that is at or below the outer contour of the vehicle seat.

13. The assembly of claim 12, further comprising a carrier member having sidewalls and a back wall so as to define an

US 7,040,697 B1

11

opening, wherein the carrier member includes at least one fastener that extends from the back wall of the carrier member and engages with the back wall of the receptacle member to secure the carrier member into the receptacle member, and wherein the video display unit is positioned within the carrier unit.

14. The assembly of claim 13, wherein the receptacle member includes a plurality of openings positioned within the back wall that receive the fasteners of the carrier member.

15. The assembly of claim 14, wherein the at least one fastener comprises a plurality of fasteners that include a central member that extends outward from back wall of the carrier member and a plurality of flexible engagement members attached to the central member, wherein the flexible engagement members are deformable so as to allow insertion of the central member into the openings in the back wall of the receptacle member, and wherein the flexible engagement members are biased outward so as to inhibit removal of the central member from the openings in the back wall of the receptacle member.

16. The assembly of claim 13, wherein the video display unit is pivotally attached to the carrier member such that the outer plane of the video display unit can be adjusted by a user about a pivot axis.

17. The assembly of claim 16, wherein the video display unit is pivotable about a substantially horizontal axis.

18. The assembly of claim 16, wherein at least a first and second fasteners are positioned through the carrier into the display unit so as to secure the video display unit to the

12

carrier member prior to installation of the carrier into the receptacle member, and wherein the at least first and second fasteners engage with the video display unit so as to define a pivot axis.

19. The assembly of claim 12, further comprising a screen cover that is dimensioned to cover the video display unit in a first configuration following installation into the seat back, and wherein the cover is selectively disengagable so as to allow visual access to the video display unit.

20. The assembly of claim 19, wherein the screen cover comprises at least a portion of the outer skin that is attached to the seat back adjacent a bottom side of the video display unit and a fastener assembly attached to the portion of outer skin and the seat back adjacent a top side of the video display unit such that the portion of outer skin can hide the video display unit from view.

21. The assembly of claim 19, wherein the screen cover includes an impact attenuating material selected from the group consisting of foam, padding, and an air cushion.

22. The assembly of claim 19, wherein the screen cover includes a generally rigid layer to provide physical protection of the video display unit.

23. The assembly of claim 12, wherein the outer skin is selected from the group consisting of fabric, leather, upholstery, and vinyl.

24. The assembly of claim 12, wherein the vehicle seat includes a head rest and the receptacle member is positioned within the head rest.

* * * * *

EXHIBIT B



US007407227B1

(12) **United States Patent**
Tuccinardi et al.

(10) **Patent No.:** **US 7,407,227 B1**
(45) **Date of Patent:** ***Aug. 5, 2008**

(54) **HEADREST HAVING AN INTEGRATED VIDEO SCREEN**

4,584,603 A 4/1986 Harrison
4,635,110 A 1/1987 Weinblatt
4,647,980 A 3/1987 Steventon et al.

(75) Inventors: **Eugene M. Tuccinardi**, Temecula, CA (US); **Ernesto R. Haack**, Perris, CA (US); **Robert Murphy**, Lake Elsinore, CA (US); **Frank Barrese**, Temecula, CA (US); **Roel C. Espina**, Loma Linda, CA (US); **Jon A. Molo**, Ontario (CA); **Theo Zoetemelk**, Riverside, CA (US)

(Continued)

FOREIGN PATENT DOCUMENTS

DE 3637772 A1 5/1988

(Continued)

OTHER PUBLICATIONS

WO 02/074577. Jost, Gilbert. Headrest, Particularly for a Motor Vehicle Seat, Sep. 26, 2002.*

(Continued)

Primary Examiner—Sarah B McPartlin

(74) *Attorney, Agent, or Firm*—Knobbe, Martens, Olson & Bear, LLP

(73) Assignee: **Timely Innovations, L.P.**, Temecula, CA (US)

(*) Notice: Subject to any disclaimer, the term of this patent is extended or adjusted under 35 U.S.C. 154(b) by 0 days.

This patent is subject to a terminal disclaimer.

(21) Appl. No.: **11/415,696**

(57) **ABSTRACT**

(22) Filed: **May 2, 2006**

Related U.S. Application Data

(63) Continuation of application No. 10/395,870, filed on Mar. 20, 2003, now Pat. No. 7,040,697.

A seat back video display assembly adapted to be positioned in the back of a vehicle seat having an outer skin cover. In one aspect, the assembly may comprise a receptacle member having sidewalls and a back wall so as to define an opening wherein the receptacle member is adapted to be positioned in the back of the vehicle seat. In addition, the assembly may further comprise a carrier member having sidewalls and a back wall so as to define an opening, wherein the carrier member includes at least one fastener that extends from the back wall of the carrier member and engages with the back wall of the receptacle member to secure the carrier member into the receptacle member. Moreover, the assembly may still further comprise a video display unit that is sized so as to be positioned secured within the opening in the carrier member, wherein the video display unit provides video signals.

(51) **Int. Cl.**

A47C 7/62 (2006.01)

(52) **U.S. Cl.** 297/217.3; 297/188.04

(58) **Field of Classification Search** 297/217.3, 297/188.04, 188.07, 408, 391; 5/643, 645

See application file for complete search history.

(56) **References Cited**

U.S. PATENT DOCUMENTS

3,004,815 A 10/1961 O'Kain et al.

14 Claims, 10 Drawing Sheets

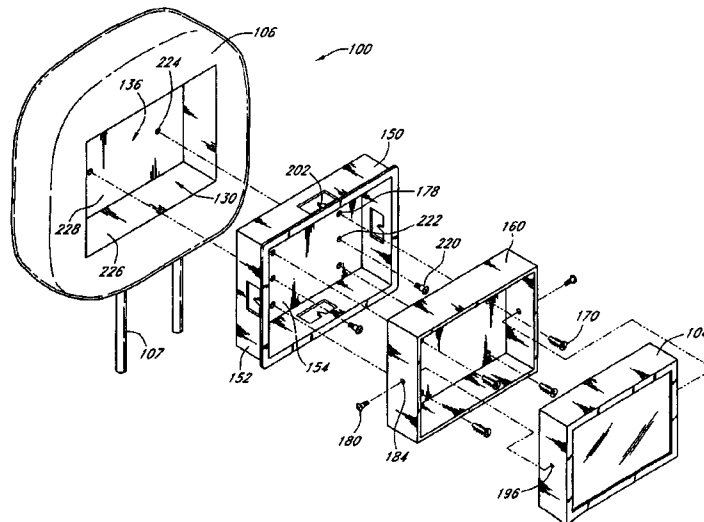

US 7,407,227 B1

Page 2

U.S. PATENT DOCUMENTS

4,681,366 A * 7/1987 Lobanoff 297/188.06
 4,756,528 A 7/1988 Umashankar
 4,776,739 A * 10/1988 Hamman 411/510
 4,788,588 A 11/1988 Tomita
 4,866,515 A 9/1989 Tagawa et al.
 RE33,423 E 11/1990 Lobanoff
 4,983,951 A 1/1991 Igarashi et al.
 5,267,775 A * 12/1993 Nguyen 297/217.3
 5,292,174 A 3/1994 Ohnuma
 5,293,244 A 3/1994 Kawaguchi
 5,311,302 A 5/1994 Berry et al.
 5,333,416 A 8/1994 Harris et al.
 5,359,349 A 10/1994 Jambor et al.
 5,507,556 A * 4/1996 Dixon 297/217.3
 5,529,265 A 6/1996 Sakurai
 5,555,466 A 9/1996 Scribner et al.
 5,640,297 A 6/1997 Labaze
 5,713,633 A 2/1998 Lu
 D398,921 S 9/1998 Rosen
 5,842,715 A 12/1998 Jones
 5,953,784 A * 9/1999 Suzuki et al. 15/209.1
 6,024,027 A 2/2000 Esmaili
 6,055,478 A 4/2000 Heron
 D434,400 S 11/2000 Rosen
 6,199,948 B1 3/2001 Bush et al.
 6,216,927 B1 4/2001 Meritt
 6,250,967 B1 6/2001 Chu
 6,292,236 B1 9/2001 Rosen
 6,305,046 B1 * 10/2001 Kingry et al. 15/231
 6,339,455 B1 1/2002 Allan et al.
 6,394,551 B1 5/2002 Beukema
 6,406,334 B2 6/2002 Chu
 6,409,242 B1 6/2002 Chang
 6,480,243 B2 11/2002 Yamamoto
 6,669,285 B1 * 12/2003 Park et al. 297/217.3
 6,739,654 B1 5/2004 Shen et al.
 6,750,599 B2 6/2004 Tajima
 6,755,491 B2 6/2004 McElheney
 6,762,929 B2 7/2004 Sawyer
 6,883,870 B2 * 4/2005 Jost 297/391
 7,036,879 B2 5/2006 Chang
 7,038,581 B2 5/2006 Kendall et al.

7,040,697 B1 * 5/2006 Tuccinardi et al. 297/217.3
 7,044,546 B2 5/2006 Chang
 2001/0008266 A1 7/2001 Lambert
 2003/0025367 A1 * 2/2003 Boudinot 297/217.3
 2004/0007906 A1 1/2004 Park et al.
 2004/0032543 A1 * 2/2004 Chang 348/837
 2004/0160096 A1 8/2004 Boudinot
 2005/0099042 A1 5/2005 Vitito
 2005/0242638 A1 11/2005 Vitito
 2007/0001492 A1 1/2007 Chang
 2007/0102973 A1 5/2007 Vitito

FOREIGN PATENT DOCUMENTS

DE 19601582 A1 1/1996
 FR 2764563 A1 12/1998
 JP 01094048 A2 4/1989

OTHER PUBLICATIONS

Office Action of Jul. 27, 2007 for U.S. Appl. No. 10/819,341.
 Response to Office Action of Jul. 27, 2007 for U.S. Appl. No. 10/819,341.
 Office Action of Jan. 31, 2007 for U.S. Appl. No. 11/415,918.
 Response to Restriction Requirement of May 10, 2007 for U.S. Appl. No. 10/819,341.
 Restriction Requirement of May 10, 2007 for U.S. Appl. No. 10/819,341.
 Response to Office Action of Jan. 31, 2007 for U.S. Appl. No. 11/415,918.
 Final Office Action of Jul. 30, 2007 for U.S. Appl. No. 11/415,918.
 RCE and Response to Final Office Action of Jul. 30, 2007 for U.S. Appl. No. 11/415,918.
 Restriction Requirement of Jul. 19, 2004 for U.S. Appl. No. 10/395,870.
 Response to Restriction Requirement of Jul. 19, 2004 for U.S. Appl. No. 10/395,870.
 Office Action of Sep. 27, 2004 for U.S. Appl. No. 10/395,870.
 Response to Office Action of Sep. 27, 2004 for U.S. Appl. No. 10/395,870.
 Final Office Action of May 3, 2005 for U.S. Appl. No. 10/395,870.
 RCE & Response to Final Action of May 3, 2005 for U.S. Appl. No. 10/395,870.
 Notice of Allowance of Dec. 6, 2005 for U.S. Appl. No. 10/395,870.

* cited by examiner

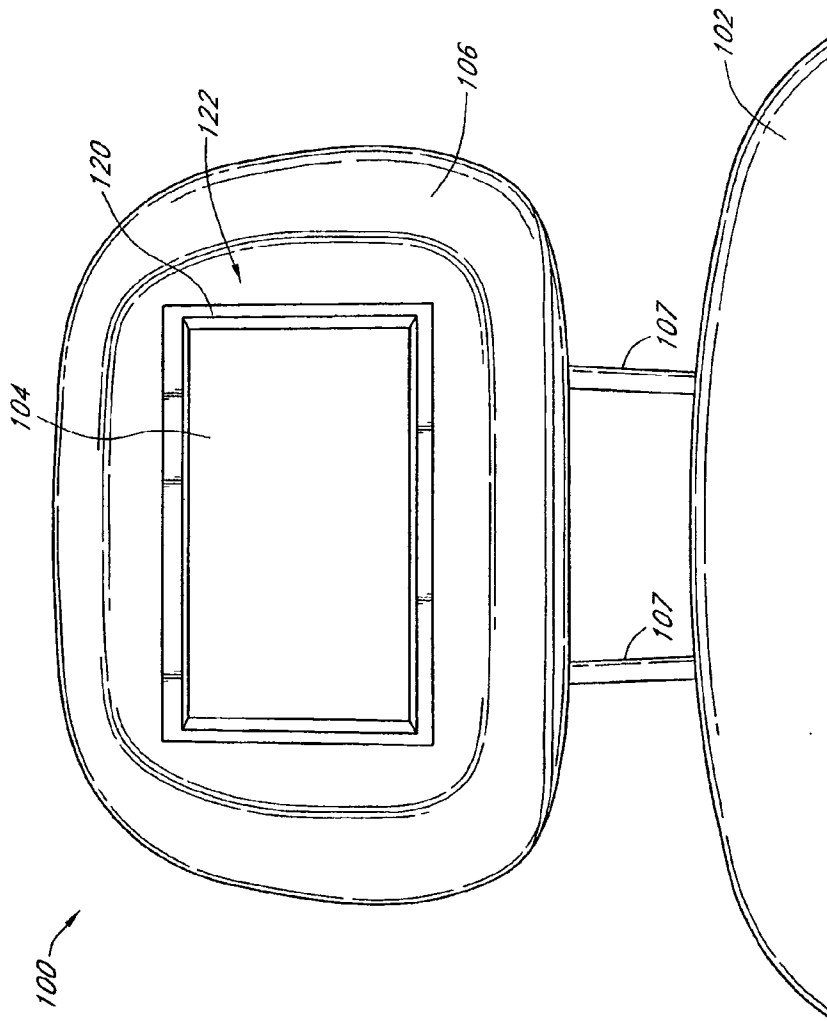

FIG. 1A

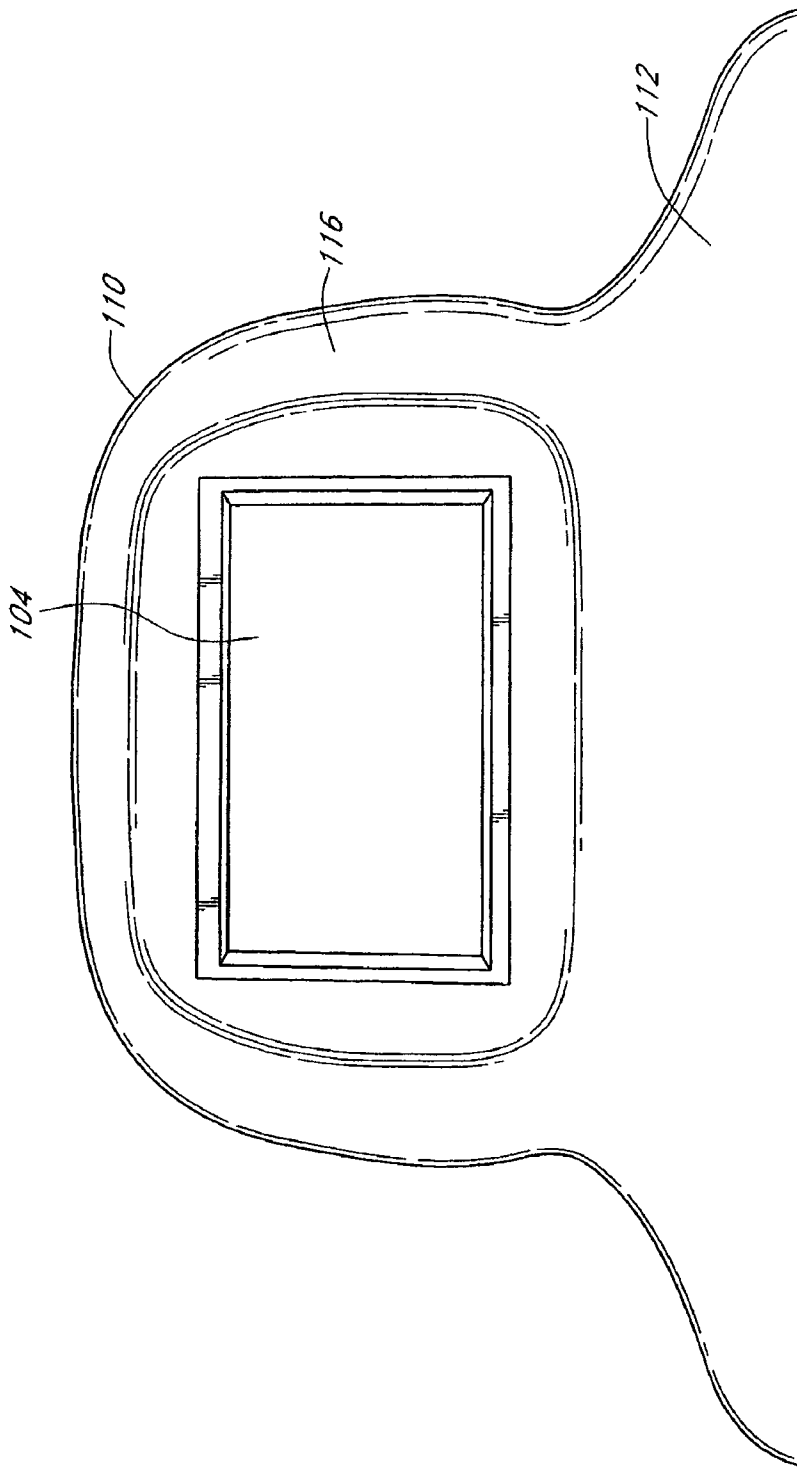

FIG. 1B

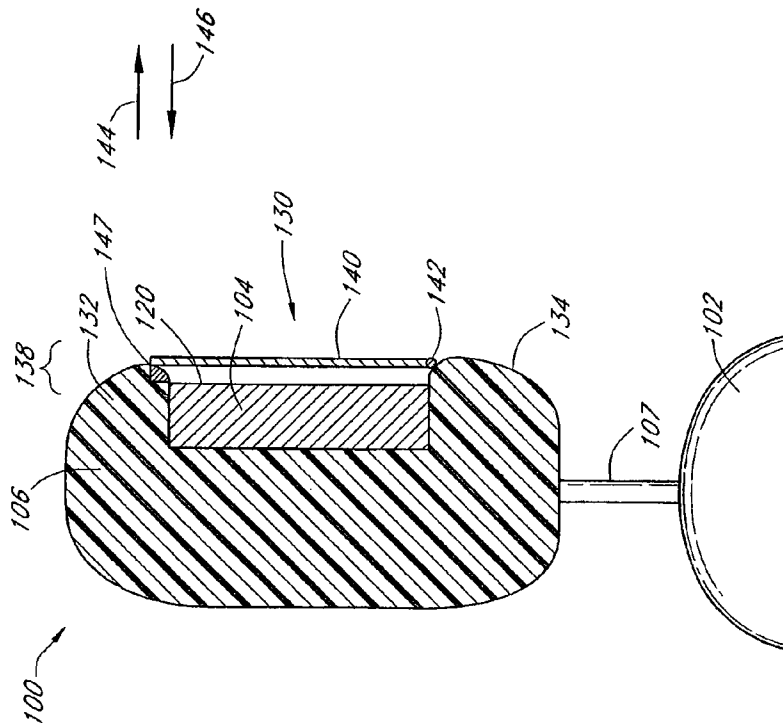

FIG. 3A

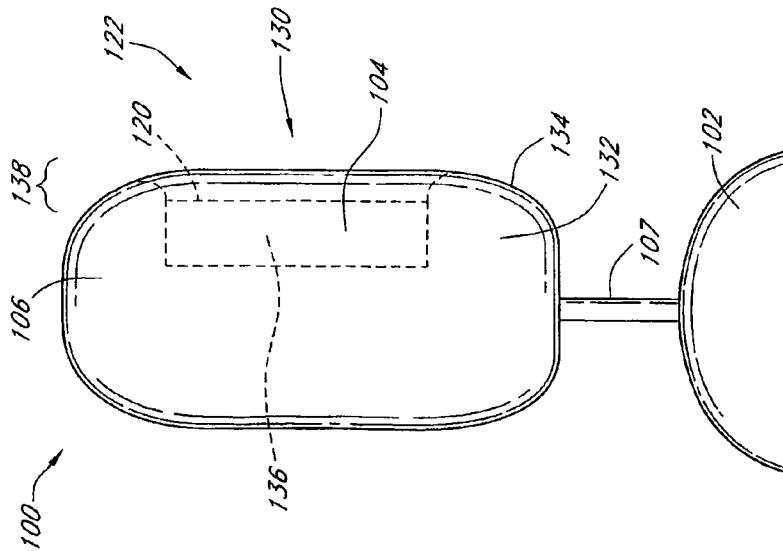

FIG. 2

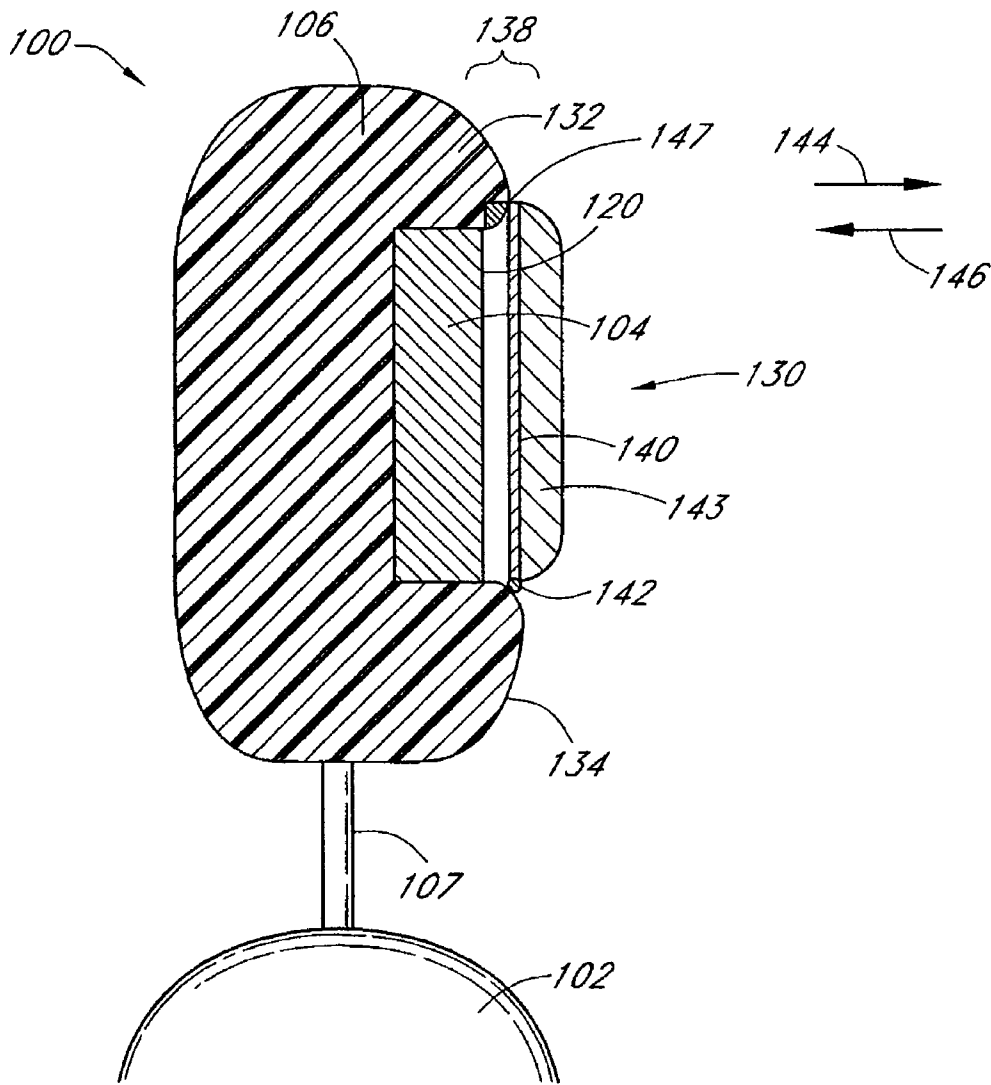

FIG. 3B

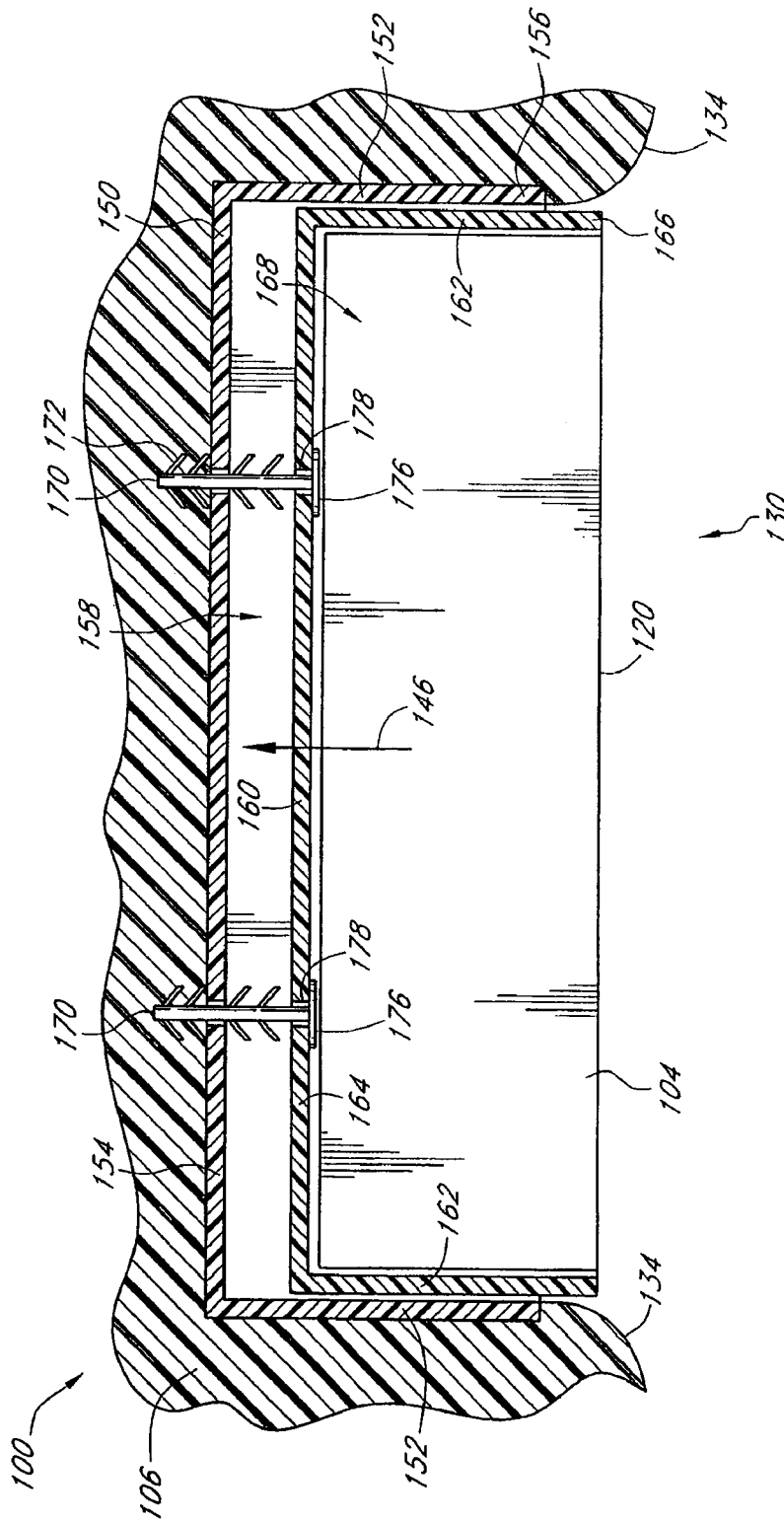

FIG. 4

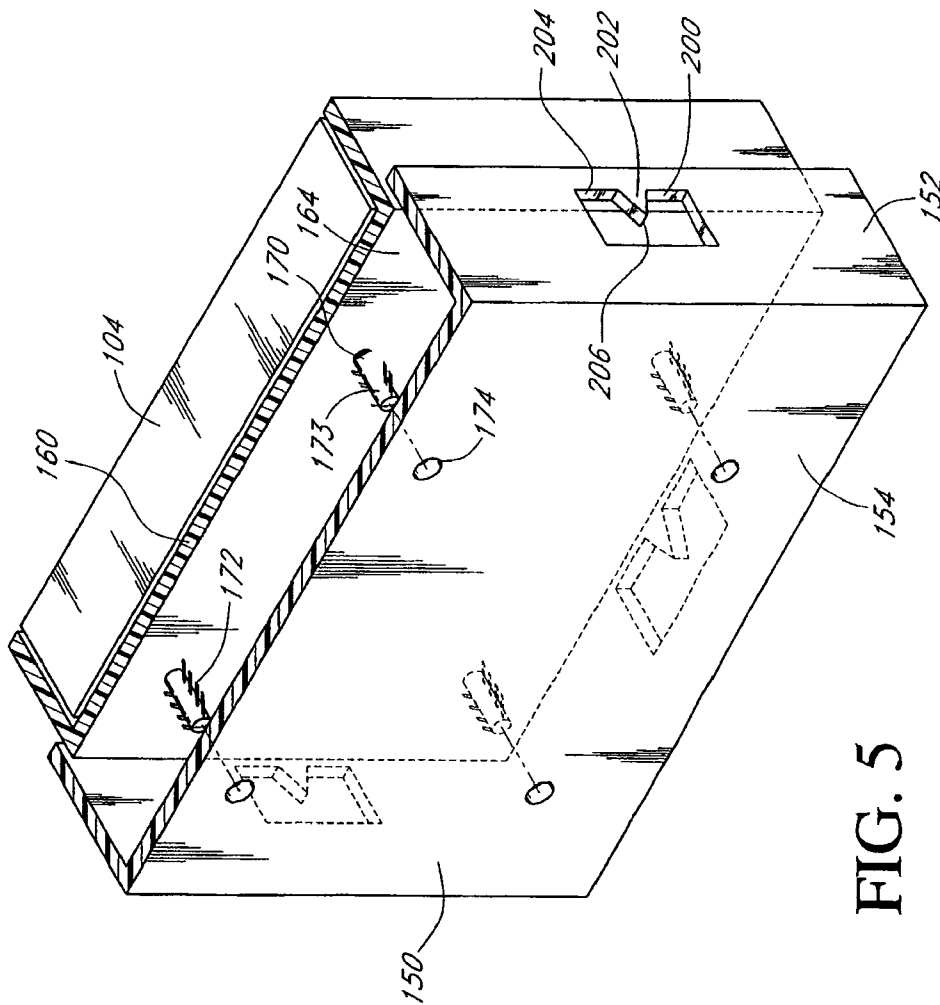

FIG. 5

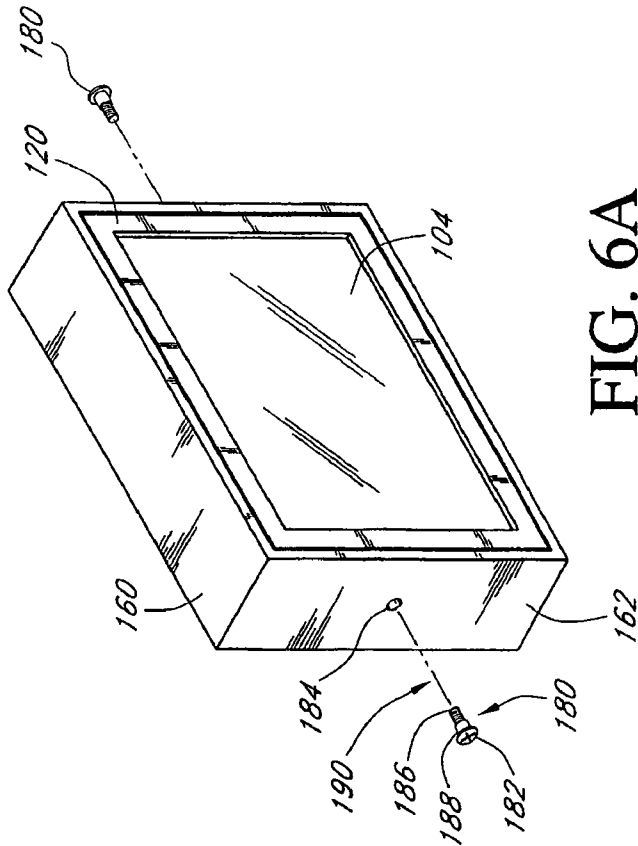

FIG. 6A

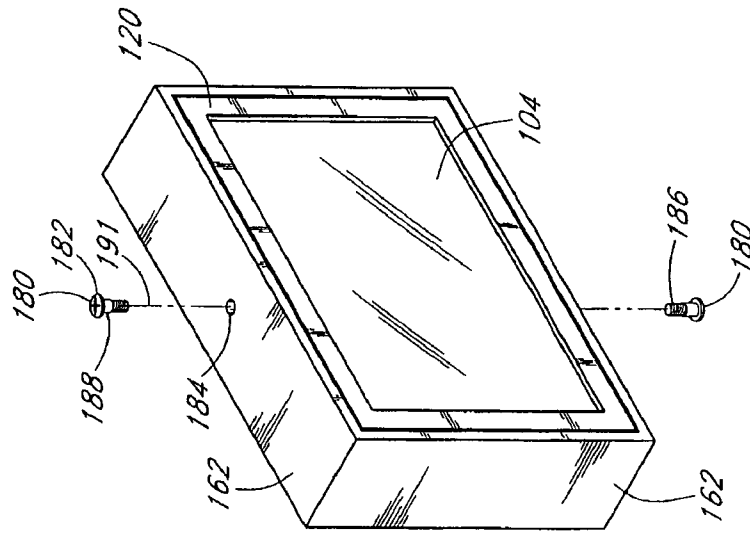

FIG. 6B

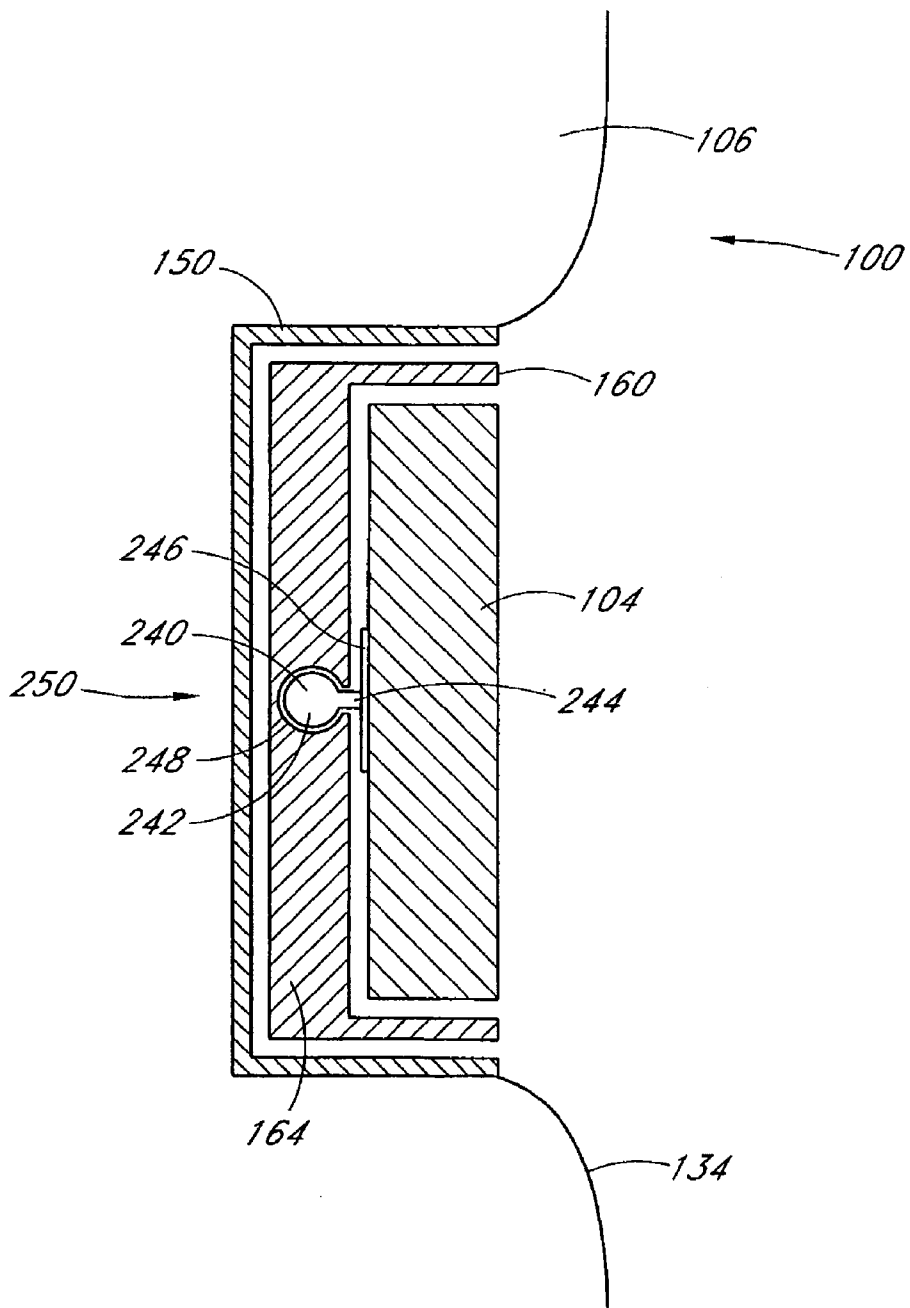

FIG. 6C

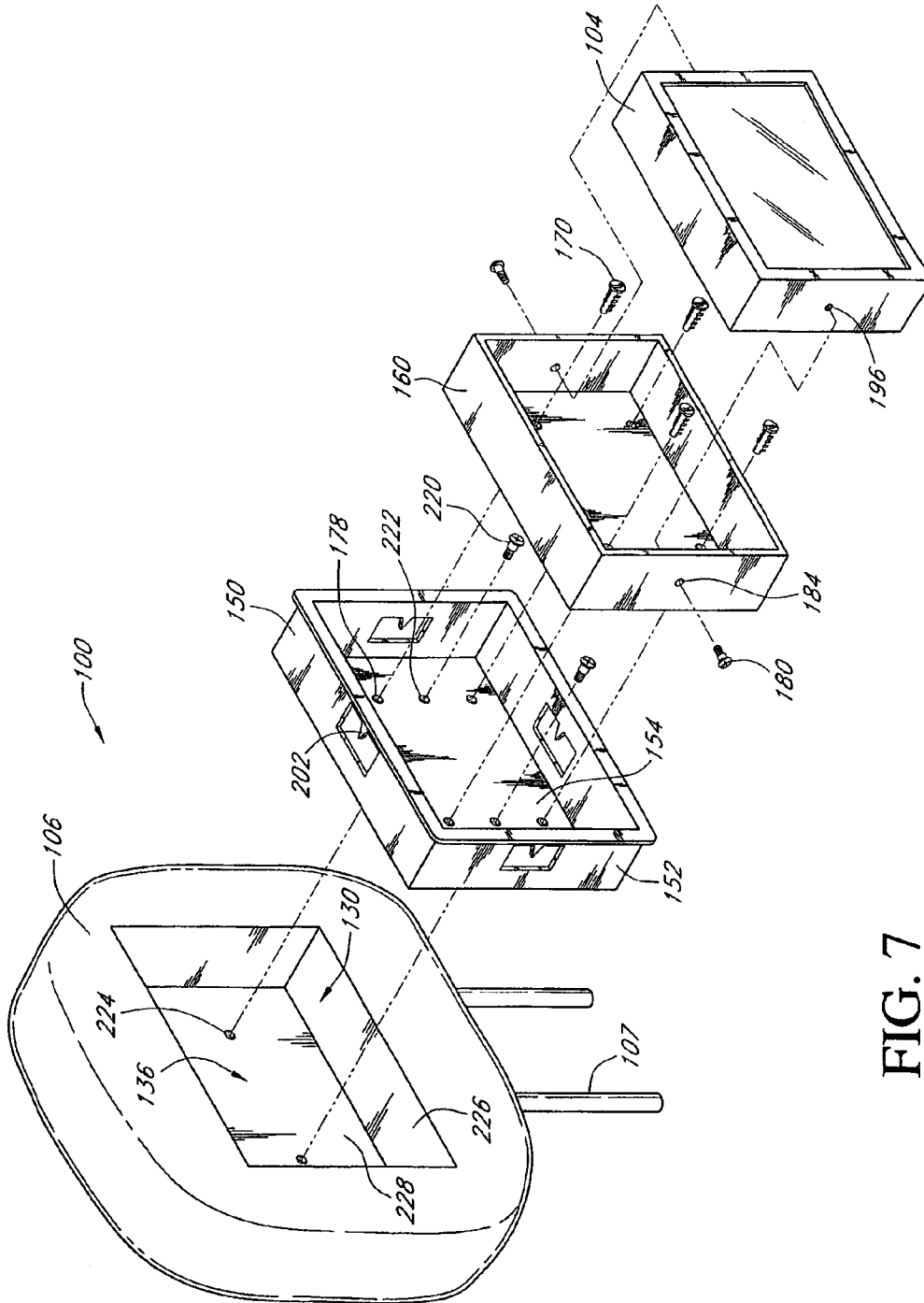

FIG. 7

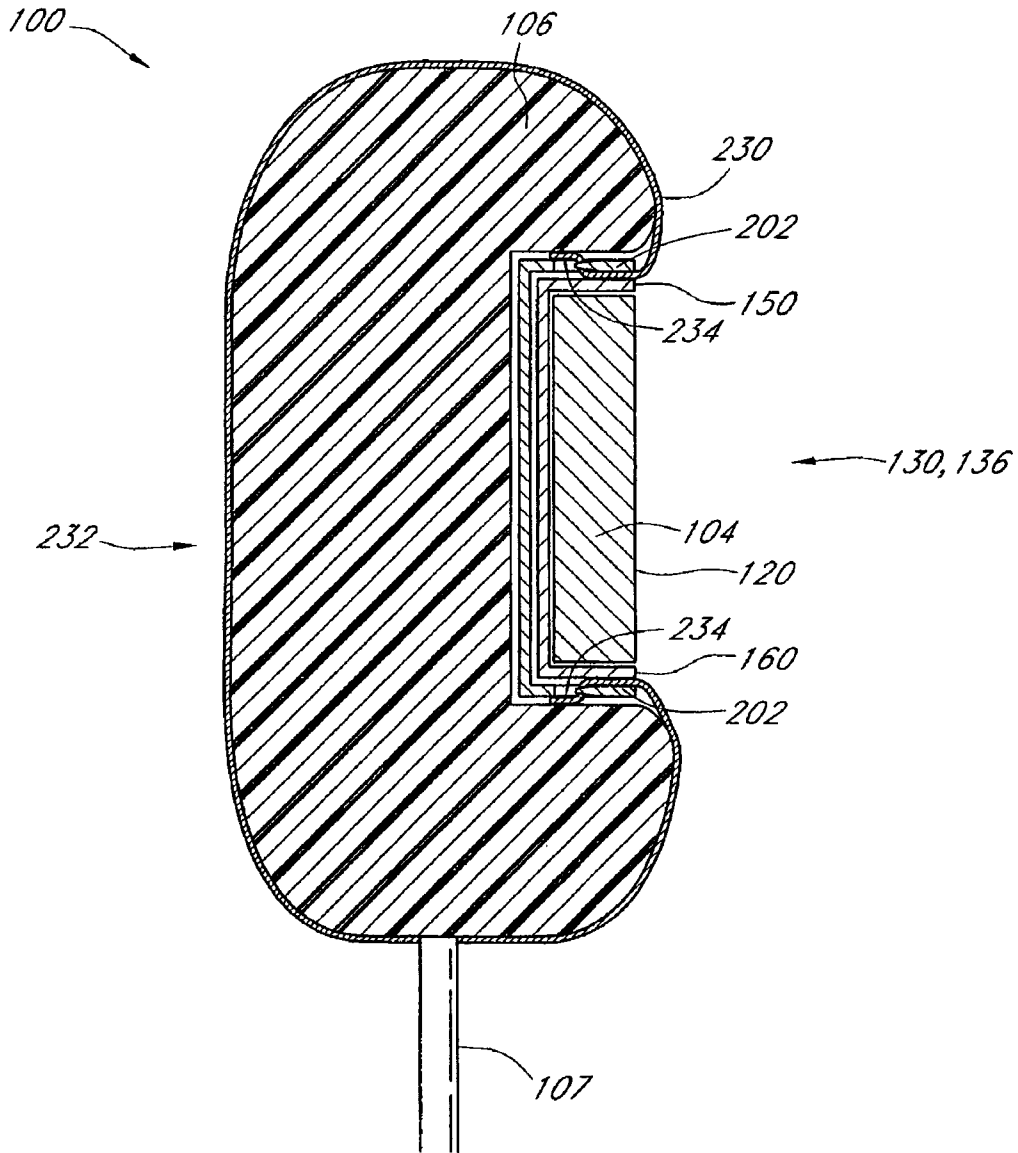

FIG. 8

US 7,407,227 B1

1

**HEADREST HAVING AN INTEGRATED
VIDEO SCREEN**

RELATED APPLICATIONS

This application is a continuation of U.S. application Ser. No. 10/395,870 filed Mar. 20, 2003 now U.S. Pat. No. 7,040,697, entitled "HEADREST HAVING AN INTEGRATED VIDEO SCREEN," which is hereby incorporated by reference herein in its entirety; and this application is related to U.S. application Ser. No. 10/819,341 filed Apr. 5, 2004, entitled "HEADREST/HEAD RESTRAINT HAVING AN INTEGRATED VIDEO SCREEN;" and to U.S. application Ser. No. 11/415,918 filed concurrently with this application, entitled "HEADREST HAVING AN INTEGRATED VIDEO SCREEN," which is a divisional of the above-identified Ser. No. 10/395,870 application.

BACKGROUND OF THE INVENTION

1. Field of the Invention

The present invention relates to motor vehicles and, in particular, to a headrest for motor vehicle seats having an integrated video screen mounted therein.

2. Description of the Related Art

Seat back video monitors are becoming increasingly popular in vehicles. Originally, these entertainment systems were largely confined to airplanes, however, recently, these systems have become much more popular with cars, trucks and SUVs. These entertainment systems provide the opportunity for passengers to view entertainment or educational video programs during long trips.

Typically, these systems have been installed as aftermarket products where the seat back is modified to accept the video display device, however, more of these systems are being installed as original equipment. Unfortunately, existing systems are often difficult and labor intensive to mount, particularly as an aftermarket product and are also subject to being dislodged.

Generally, the devices are mounted on the outer surface of the seat back where they protrude. In many vehicles, the space between seats and seat backs is limited, hence the protruding video display unit can inhibit the ability of passengers to easily get into and out of the vehicles. Moreover, passenger contact with the protruding video display screen may result in the screens being inadvertently dislodged.

A further difficulty with many existing video display unit designs is that they are not well secured to the seat. This is particularly the case for designs that allow the video display unit to pivot about an axis to improve the viewing angle of the passenger. One common way that these display units are installed is that a bucket is installed into the seat and the peripheral rim of the bucket includes openings that receive pivot posts that extend outward from the housing of the display unit. The pivot posts are positioned within the openings and keepers or caps are then positioned in the openings to prevent the pivot posts from being removed from the openings.

In these designs, the keepers or caps are generally press fit and are exposed to the passenger. Hence, inadvertent contact may result in the keepers or caps being dislodged. Moreover, many of the passengers are children who, through boredom, may attempt to remove the keepers which can result in the video display being dislodged and potentially damaged.

Hence, from the foregoing, there is a need for a seat back video display system and method of mounting that provides more secure mounting of the video display unit. To this end,

2

there is a need for an assembly that is less likely to be dislodged through inadvertent contact and does not have exposed detachable mounting components.

SUMMARY OF THE INVENTION

The aforementioned needs may be satisfied by a seat back video display assembly adapted to be positioned in the back of a vehicle seat having an outer skin cover. In one aspect, the assembly may comprise a receptacle member having sidewalls and a back wall so as to define an opening, wherein the receptacle member is adapted to be positioned in the back of the vehicle seat. In addition the assembly may further comprise a carrier member having sidewalls and a back wall so as to define an opening, wherein the carrier member includes at least one fastener that extends from the back wall of the carrier member and engages with the back wall of the receptacle member to secure the carrier member into the receptacle member, and a video display unit that is sized so as to be positioned secured within the opening in the carrier member, wherein the video display unit provides video signals.

Additionally, in one embodiment, the at least one fastener may comprise a plurality of fasteners that include a central member that extends outward from back wall of the carrier member and a plurality of flexible engagement members attached to the central member, wherein the flexible engagement members are deformable so as to allow insertion of the central member into the openings in the back wall of the receptacle member, and wherein the flexible engagement members are biased outward so as to inhibit removal of the central member from the openings in the back wall of the receptacle member. Also, the video display unit may be pivotally attached to the carrier member such that the plane of the video display unit can be adjusted by a user about a pivot point or axis, wherein the video display unit may be pivotable about a substantially horizontal pivot axis, a substantially vertical pivot axis, or pivot point that allows a continuous range of pivotal motion about the pivot point. Also, the openings may be positioned in the sidewalls of the receptacle member and the plurality of capture members are positioned within the openings, and wherein the plurality of capture members define a pointed surface that engages with the outer skin and inhibits removal of the outer skin from the opening defined by the receptacle member so as to securely fasten the outer skin to the receptacle member.

Additionally, in certain embodiments, the seat back video display assembly includes a screen cover that is dimensioned to cover the video display unit such that the screen cover can disengageably cover the screen of the video display unit to occlude the screen. The screen cover can include an impact attenuating material, a rigid protective layer, or any combination thereof.

The aforementioned needs may also be satisfied by a vehicle seat assembly having a seat back display. In one aspect, the vehicle seat assembly may comprise a vehicle seat adapted to receive an occupant during travel of a vehicle, the vehicle seat defining a seat back with an outer contour and a skin, and a receptacle member having sidewalls and a back wall to as to define an opening, wherein the receptacle member is mounted in the seat back of the vehicle seat such that the sidewalls are located at or below the outer contour of the seat back. In addition, the vehicle seat assembly may further comprise a video display unit mounted within the receptacle member, wherein the video display unit is generally planar with the outer plane being mounted at or below the outer contour of the seat back.

US 7,407,227 B1

3

Moreover, the aforementioned needs may also be satisfied by a method of installing a video display unit into a seat back of a vehicle seat. In one embodiment, the method may comprise cutting an opening through an outer skin of the seat back, forming an aperture in the seat back, and positioning a receptacle in the aperture such that the receptacle is mounted at or below the level of the seat back. In addition, the method may comprise securing the video display unit to a carrier, and mounting the carrier into the receptacle such that an upper surface of the video display unit is mounted below the outer surface of the seat back. These and other objects and advantages of the present invention will become more fully apparent from the following description taken in conjunction with the accompanying drawings.

BRIEF DESCRIPTION OF THE DRAWINGS

FIG. 1A illustrates an adjustable headrest for a motor vehicle seat having an integrated video screen mounted therein.

FIG. 1B illustrates a fixed headrest for a motor vehicle seat having the integrated video screen of FIG. 1A mounted therein.

FIG. 2 illustrates a side view of the adjustable headrest shown in FIG. 1A having the integrated video screen mounted therein with a recessed orientation.

FIGS. 3A, 3B illustrate a cross-sectional view of the adjustable headrest shown in FIG. 1A having the integrated video screen mounted therein with a screen cover.

FIG. 4 illustrates a cross-sectional view of the integrated video screen being mounted to the headrest via a carrier receptacle, a carrier member, and a plurality of fasteners.

FIG. 5 illustrates a perspective view of the integrated video screen being mounted to the headrest via the carrier member and the plurality of fasteners of FIG. 4.

FIGS. 6A, 6B illustrate a perspective view of mounting the integrated video screen to the carrier member.

FIG. 6C illustrates a side view of mounting the integrated video screen to the carrier member via pivot member.

FIG. 7 illustrates a perspective view of mounting the integrated video screen to the adjustable headrest of FIG. 1A.

FIG. 8 illustrates a cross-sectional view of the video screen mounted to the headrest, wherein an outer skin from the headrest is secured to the carrier receptacle.

DETAILED DESCRIPTION OF THE PREFERRED EMBODIMENT

Reference will now be made to the drawings wherein like numerals refer to like parts throughout. A headrest for motor vehicle seats having an integrated video screen mounted therein in a flush or recessed manner will be described in greater detail herein below with reference to the drawings. In one aspect, it should be appreciated that the term motor vehicle seats refers to a plurality of generally known motor vehicles seats, such as those manufactured for automobiles, buses, boats, cars, semi-trucks, etc., wherein the following discussion can be similarly applied to these various types of motor vehicle seats without departing from scope of the present teachings. In addition, the following discussion refers to mounting the integrated video screen to the headrest of motor vehicle seats but may also be applied to other various component features of motor vehicle seats, such as the seat back, without departing from the scope of the present teachings.

FIG. 1A illustrates an adjustable headrest 100 for a first motor vehicle seat 102 having an integrated video screen 104

4

mounted therein. As illustrated in FIG. 1A, the adjustable headrest 100 is coupled to the seat 102 via posts 107 that extend therefrom and allow vertical adjustment of the adjustable headrest 100 with respect to the seat 102 in a generally known manner. FIG. 1B illustrates a fixed headrest 110 for a second motor vehicle seat 112 having the integrated video screen 104 mounted therein. In one embodiment, the video screen 104 is mounted within a headrest bun 106, 116 that is adapted to receive the video screen 104 for firm attachment therein in a manner that will be described in greater detail herein below. In addition, as will be described in greater detail herein below, the video screen 102 is mounted such that a front surface 120 of the video screen 104 is either flush or recessed from a contour 122 of the headrest 100, 110.

In one embodiment, the video screen 104 comprises a generally known LCD (liquid crystal display) monitor or terminal that can be electrically coupled to a video entertainment system so as to receive video signals therefrom for viewing of movies, television, internet web pages, video games, etc. As illustrated, the video screen 104 is generally rectangular in shape with the planar front surface 120 that is viewable by a user. In one aspect, it should be appreciated that the degree of recessed depth (with no depth comprising a flush mount) of the integrated video screen 104 and the manner in which the contour 122 of the seat 102, 112 is shaped may be selected such that the shape (side view, for example) of the headrest 100, 110 with the integrated video screen 104 mounted therein is generally similar to the shape of the headrest 100, 110 without the integrated video screen 104. Moreover, it should be appreciated that the motor vehicle seats 102, 112 may comprise any one of a number of various types or models of generally known motor vehicle seats without departing from the scope of the present invention.

FIG. 2 illustrates a side view of the adjustable headrest 100 shown in FIG. 1A having the integrated video screen 104 mounted therein with a recessed orientation. It should be appreciated that the following discussion is with respect to the adjustable headrest 100 of FIG. 1A but may be similarly applied to the fixed headrest 110 of FIG. 1B without departing from the scope of the present teachings.

FIG. 2 further illustrates the side view shape or contour 122 of the headrest 100. As illustrated in FIG. 2, the contour 122 of the headrest 100 is maintained due to the recessed orientation of the video screen 104 within the headrest bun 106. In addition, an opening 130 is formed in a rear section 132 of the headrest 100 so as to define a substantially rectangular interior region 136 within the headrest bun 106 below an outer surface 134 of the headrest 100. As further illustrated in FIG. 2, the video screen 104 can then be positioned adjacent the opening 130 so as to be firmly positioned within the interior region 136 of the headrest bun 106. Moreover, the recessed orientation may be defined by a depth 138 between the front surface 120 of the video screen 104 and the outer surface 134 of the headrest 100. The depth 138 therebetween may vary in magnitude depending on the thickness of the headrest bun 106 and/or the internal structural characteristics of the headrest 100, which may vary with respect to the type or model of motor vehicle seat used. In one aspect, the depth 138 of the recessed orientation may comprise a magnitude of approximately zero so as to define a flush mounted video screen 104, wherein the front surface 1120 of the video screen 104 is substantially aligned with the outer surface 134 of the headrest 100.

FIG. 3A illustrates a cross-sectional view of the adjustable headrest 102 shown in FIG. 1A having the integrated video screen 104 mounted therein with the recessed orientation shown in FIG. 2 and a screen cover 140. In one embodiment,

US 7,407,227 B1

5

the screen cover 140 is coupled to the rear section 132 of the headrest 100 via a hinge 142 so as to overlie the video screen 104 and at least part of the opening 130 formed therein. The screen cover 140 may comprise generally rectangular shape and is oriented generally parallel to the front surface 120 of the video screen 104 so as to temporarily occlude the video screen 104. In one aspect, as further illustrated in FIG. 3A, the screen cover 140 can be positioned adjacent the opening 130 so as to substantially align with the outer surface 134 of the headrest 100 thus forming a flush mounting therewith. It should be appreciated that the screen cover 140 may be positioned within the opening 130 so as to be recessed with respect to the outer surface 134 of the headrest 100 without departing from the scope of the present teachings. Moreover, the screen cover 140 may comprise a rigid material, such as plastic, metal, etc. Alternatively, in another aspect, the screen cover 140 may comprise a piece or flap of material from an outer skin 230 (FIG. 8) of the motor vehicle seat 102 that is attached to the headrest 100 adjacent the lower side of the video screen 104.

In still another aspect, as illustrated in FIG. 3B, the screen cover 140 may comprise an impact attenuating section 143 comprising a material such as foam, various types of padding, an air cushion, etc. so as to soften the force of an impact from an object. For example, during a car accident, a person's head may be propelled towards the screen cover 140, wherein the impact attenuating material may soften the impact to the headrest 102 to thereby protect the person's head and the video screen 104 from damage.

Also, in one embodiment, the video screen 104 can be viewed by opening the screen cover 140 or temporarily occluded by closing the screen cover 140. Hence, the screen cover 140 can be outwardly rotated about the hinge 142 in a first direction 144 to openly view the video screen 104, or the screen cover 140 can be inwardly rotated about the hinge 142 in a second direction 144 opposite the first direction 144 to temporarily occlude the video screen 104. Advantageously, the screen cover 104, when closed, conceals the video screen 104 from view thus, in some situations, functions as a thief deterrent.

Moreover, in one aspect, the recessed configuration of the video screen 104 facilitates the manner in which the screen cover 140 may be deployed. For example, the video screen 104 may not physically interfere with the closing of the screen cover 140. In addition, as illustrated in FIGS. 3A, 3B, the screen cover 140 is intended to "hide" the video screen 104 from outside observers, thereby reducing the probability that the video screen 104 will be a target of theft. As further illustrated in FIGS. 3A, 3B, the screen cover 140 may further comprise a means for engagement 147 that allows the screen cover 140 to remain in the "up" or closed configuration. In general, it should be appreciated that some possible means for achieving such an engagement include but are not limited to magnetic strips, mechanical clips, velcro strips, and the like.

FIG. 4 illustrates a cross-sectional view of the integrated video screen 104 being mounted to the headrest 100 via a carrier receptacle 150, a carrier member 160, and first fasteners 170. FIG. 5 illustrates a perspective view of the integrated video screen 104 being mounted to the headrest 100 via the carrier receptacle 150, the carrier member 152, and the first fasteners 170. In one embodiment, the carrier receptacle 150 comprises a plurality of planar sidewalls 152 and a rear planar wall 154 that are joined together in a manner so as to form a substantially rectangular outer structure 156 having an inner recessed region 158 that is adapted to receive the carrier member 152 therein. Similarly, the carrier member 152 comprises a plurality of planar sidewalls 162 and a rear planar wall

6

164 that are joined together in a manner so as to form a substantially rectangular outer structure 166 having an inner recessed region 168 that is adapted to receive the video screen 104 therein.

As illustrated in FIG. 4, the video screen 104 may be mounted within the carrier member 160 via side fasteners 180 (shown in FIGS. 6A, 6B) and then the carrier member 152 is mounted within the carrier receptacle 150 via the first fasteners 170 so as to simplify the mounting of the video screen 104 to the headrest 100 including the headrest bun 106. In one aspect, the first fasteners 170 may comprise a plurality of flexible engagement members 172 that extend therefrom so as to mechanically couple with a plurality of mounting apertures 174 (FIG. 5) formed in the rear wall 154 of the carrier receptacle 150. The first fasteners 170 may further comprise a central member 173 that extends outward from the rear wall 164 of the carrier member 160. Also, the flexible engagement members 172 are attached to the central member 173, wherein the flexible engagement members 172 are deformable so as to allow insertion of the central member 173 into the mounting apertures 174 in the rear wall 164 of the carrier receptacle 150. Moreover, the flexible engagement members 170 are biased outward so as to inhibit removal of the central member 173 from the mounting apertures 174 in the rear wall 154 of the carrier receptacle 150. In addition, the first fasteners 170 comprise a head 176 that abuts the rear wall 164 of the carrier member 152 and is positioned through a plurality of second apertures 178 formed in the rear wall 164 of the carrier member 152.

Advantageously, the video screen 104 can be mounted to the headrest 100 via the carrier receptacle 150 and the carrier member 152 without using external fasteners that may be seen. Hence, the video screen 104 can be mounted to the headrest 100 in a more aesthetically appealing manner, wherein the front surface 120 of the video screen 104 recessed or flush mounted with respect to the outer surface 134 of the headrest 100, and wherein the first and second fasteners 170, 180 are concealed from view.

As illustrated in FIG. 5, the sidewalls 152 of the carrier receptacle 150 each comprise at least one sidewall aperture 200 having at least one serrated tooth 202 protruding from an interior sidewall 204. In one embodiment, the at least one serrated tooth 202 is triangular in shape having a pointed tip 206 that projects outward from the interior sidewall 204 in a horizontal manner. It should be appreciated that the serrated tooth 202 may comprise any one of a number of various shapes known in the art without departing from the scope of the present teachings. Additionally, as will be shown in FIG. 8, the pointed tip 234 engages with the outer skin 230 (FIG. 8) and inhibits removal of the outer skin 230 from the at least one sidewall aperture 200 formed in the carrier receptacle 150. Advantageously, as will be described in greater detail herein below, the serrated tooth 200 allows outer skin from the motor vehicle seat 102, 112 to be attached to the carrier receptacle 150 by wrapping the outer skin around the planar sidewalls 152 and into the recessed region 158 of the carrier receptacle 150 and then securing the outer skin to the serrated tooth 200.

FIG. 6A illustrates a perspective view of attaching the integrated video screen 104 to the carrier member 152 via the second fasteners 180. In one embodiment, the planar sidewalls 162 of the carrier member 160 comprise pivot apertures 184 that allow the video display 104 to be mounted to the carrier member 160. Also, the pivot apertures 184 are adapted to rotatably receive the second fasteners 180. As illustrated in FIG. 6A, the second fasteners 180 comprise a threaded region 186 that mechanically couples to threaded apertures 196 (FIG. 7) formed in the video screen 104 in a generally known

manner so as to be securely attached thereto. Moreover, the second fasteners 180 further comprise a head 182 and a smooth pivot region 188 interposed between the threaded region and the head 182.

In one aspect, the pivot region 188 of the second fastener 180 rotatably communicates with the pivot aperture 184 of the carrier member 160 to thereby allow the video screen 104 to pivot or tilt with respect to the carrier member 160 and/or the headrest 100 along a horizontal pivot axis 190 defined by the horizontally mounted second fasteners 180. Hence, the video screen 104 is pivotally attached to the carrier member 160 such that the plane of the video screen 104 can be adjusted with respect to the headrest 100 by a user about the defined horizontal pivot axis 190. Advantageously, the horizontal pivot axis 190 allows the video screen 104 to readily pivot when mounted to the headrest 100 to thereby allow greater positional flexibility during viewing of the video screen 104 by a user.

FIG. 6B further illustrates a perspective view of attaching the integrated video screen 104 to the carrier member 152 via the second fasteners 180. In one embodiment, as illustrated in FIG. 6B, the second fasteners 180 can be mounted vertically through the planar sidewalls 162 of the carrier member 160. The pivot region 188 of the vertically mounted second fasteners 180 rotatably communicates with the pivot aperture 184 of the carrier member 160 to thereby allow the video screen 104 to pivot or tilt side-to-side with respect to the carrier member 160 and/or the headrest 100 along a vertical pivot axis 191 defined by the vertically mounted second fasteners 180. Hence, the video screen 104 is pivotally attached to the carrier member 160 such that the plane of the video screen 104 can be adjusted with respect to the headrest 100 by a user about the vertical pivot axis 191. Advantageously, the vertical pivot axis 191 allows the video screen 104 to readily pivot when mounted to the headrest 100 to thereby allow greater positional flexibility during viewing of the video screen 104 by a user.

In one aspect, it should be appreciated that the second fasteners 180 may comprise generally known screws, such as sheet metal screws, without departing from the scope of the present invention. It should also be appreciated that the pivot region 188 of the second fasteners 180 may be threaded in a manner such that the video screen 104 can still pivot with respect to the carrier member 150 without departing from the scope of the present invention.

FIG. 6C illustrates a view of attaching the integrated video screen 104 to the carrier member 152 via a pivot member 240. In one embodiment, as illustrated in FIG. 6C, the pivot member 240 comprises a spherical ball 242 attached to the video screen 104 via a shaft 244 and a plate 246. The spherical ball 242 is positioned within a spherical receptacle 248 formed in the rear wall 164 of the carrier member 160. As illustrated in FIG. 6C, the rear wall 164 of the carrier member 160 may be dimensioned so as to accommodate the spherical receptacle 248. In one aspect, the plate 246 of the pivot member 240 may be attached to the video screen 104 using an adhesive, such as epoxy or glue, or fasteners, such as screws or bolts. In addition, the shaft 244 distally extends from the plate 246 towards the spherical receptacle 248 of the carrier member 160. Also, the shaft 244 and the spherical ball 242 may be formed as an integral part of the plate 246 or may be formed separately and interconnected to the plate 246 via an adhesive or fasteners.

Moreover, once the pivot member 240 is attached to the video screen 104 in a manner as previously described, the spherical ball 242 of the pivot member 240 can be pressed to fit within the spherical receptacle 248 formed in the rear wall 164 of the carrier member 160. In one aspect, the spherical ball 242 may be sized at least less than the size of the spherical receptacle 248 so as to allow rotational movement therein. Advantageously, the resulting interconnection between the

spherical ball 242 of the pivot member 240 and the spherical receptacle 248 of the carrier member 160 defines a pivot point 250 to thereby allow the video screen 104 to pivot, tilt, or rotate in a multi-directional manner with respect to the defined pivot point 250. Therefore, the defined pivot point 250 allows the video screen 104 to readily pivot when mounted to the headrest 100 to thereby allow greater positional flexibility during viewing of the video screen 104 by a user.

FIG. 7 illustrates a perspective view of mounting the integrated video screen 104 to the headrest 100 of FIG. 1A. In one embodiment, as illustrated in FIG. 7, the opening 130 is formed in the headrest bun 106 so as to define the substantially rectangular interior region 136 and to receive the carrier receptacle 150. The carrier receptacle 150 can then be positioned within the opening 130 so that the planar sidewalls 152 and the planar rear wall 154 abut the interior walls 226 of the mounting recess 136 formed in the headrest bun 106. In one embodiment, the carrier receptacle 150 can be secured to the headrest 100 via one or more third fasteners 220, such as screws, machine screws, sheet metal screws, etc. As illustrated in FIG. 7, the third fasteners 220 are positioned through rear wall apertures 222 formed in the rear wall 154 of the carrier receptacle 150 and coupled to rear mounting apertures 224 formed in a back wall 226 of the mounting recess 136 of the headrest bun 106. Advantageously, the third fasteners 220 can be securely attached to a structural component (not shown) of the headrest 100, such as an internal framework member of the headrest 100, so as to form a rigid attachment between the carrier receptacle 150 and the headrest 100.

In addition, the video screen 104 may be mounted to the carrier member 160 so as to pivot with respect thereto in a manner as previously described with reference to FIGS. 6A, 6B, 6C. Following, the carrier member 160 including the video screen 104 can then be mounted to the carrier receptacle 150 via the first fasteners 170 in a manner as previously described with reference to FIG. 4. Advantageously, this method of attaching the video screen 104 to the headrest 100 via the carrier receptacle 150, the carrier member 160, and the fasteners 170, 180 allows the video screen 104 to be securely mounted to the headrest 100 while providing a means for pivoting the video screen 104 with respect to the headrest 100 so as to improve the viewing range by a user.

FIG. 8 illustrates a cross-sectional view of the video screen 104 mounted to the headrest 100, wherein the outer skin 230 of the headrest 100 of the motor vehicle seat 102 is attached to the carrier receptacle 150 and the carrier member 160 with the video screen 104 mounted therein is mounted within the mounting recess 136 of the carrier receptacle 150. As is generally known, many motor vehicle car seats comprise the illustrated outer skin 230, such as fabric, leather, upholstery, vinyl, etc., that provides a outer surface 232 for a user to lean against or rest upon. In one aspect, when mounting the integrated video screen 104 into the headrest 100 of the motor vehicle seat 102, the outer skin 230 is adapted to accommodate the video screen 104 including the carrier receptacle 150. In some situations, one or more flaps 234 can be formed in the outer skin 230 and attached to the one or more serrated teeth 202 formed in the planar sidewalls 152 of the carrier receptacle 150.

As further illustrated in FIG. 8, the carrier receptacle 150 may be positioned within the mounting recess 136 formed in the headrest bun 106, and then the outer skin 230 is secured to the serrated teeth 202 via the flaps 234 formed therein by hooking the flaps 234 to one or more of the serrated teeth 202. Once the outer skin 230 is attached to the serrated teeth 202 via the flaps 234, the carrier member 160 is firmly pressed within the mounting recess 136 of the headrest bun 106 so that the first fasteners 170 couple to the mounting apertures 174 formed in the rear wall 154 of the carrier receptacle 150.

Advantageously, this interconnection between the carrier member 160 and carrier receptacle 150 provides a quick and easy means for mounting of the video screen 104 to the headrest 100. In addition, the pressed fit of the outer skin between the carrier member 160 and the carrier receptacle 150 further secures the outer skin of the motor vehicle seat 102 to the carrier receptacle 150. As a result, the outer skin is securely held to the carrier receptacle 150 via the one or more serrated teeth 202 formed in the planar sidewalls 152 of the carrier receptacle 150 and the pressed fit of the carrier member 160 within the mourning recess 136 of the carrier receptacle 150.

Although the foregoing description has shown, described and pointed out the fundamental novel features of the invention, it will be understood that various omissions, substitutions, and changes in the form of the detail of the apparatus as illustrated, as well as the uses thereof, may be made by those skilled in the art, without departing from the spirit or scope of the present invention. Consequently, the scope of the invention should not be limited to the foregoing discussion, but should be defined by the appended claims.

What is claimed is:

1. A headrest assembly for a vehicle seat, the assembly comprising:

a receptacle member having a plurality of sidewalls and a back wall so as to define an opening wherein the receptacle member is adapted to be positioned in a back of the vehicle seat wherein the opening is facing away from the back of the vehicle seat when the receptacle member is positioned within the back of the vehicle seat and wherein the back wall of the receptacle member defines at least one securing aperture;

a carrier member having a plurality of sidewalls and a back wall so as to define an opening, wherein the opening in the carrier member is facing away from the back of the vehicle seat when the carrier member is positioned within the receptacle member and wherein the back wall of the carrier member defines at least one securing aperture;

an outer skin having edges that extend into the opening of the receptacle member and attached to at least some of the plurality of sidewalls of the receptacle member and wherein the edges of the outer skin are substantially concealed when the carrier member is positioned within the opening of the receptacle member;

at least one fastener that extends through the at least one securing aperture of the carrier member and engages with the at least one securing aperture of the receptacle member to allow securing of the carrier member in the opening of the receptacle member;

a video display unit that is sized so as to be positioned within the opening in the carrier member and substantially conceal the at least one fastener when in a viewing orientation.

2. The assembly of claim 1, wherein the at least one fastener comprises a plurality of fasteners that include a central member dimensioned to extend through the securing aperture of the carrier member and a plurality of flexible engagement members attached to the central member, wherein the flexible engagement members are deformable so as to allow insertion of the central member into the corresponding securing aperture of the receptacle member, and wherein the flexible engagement members are biased outward so as to inhibit removal of the central member from the apertures of the receptacle member.

3. The assembly of claim 1, wherein the video display unit defines a plane and is pivotally attached to the carrier member such that the plane of the video display unit can be adjusted by a user about a pivot axis.

4. The assembly of claim 3, wherein the video display unit is pivotable about a substantially horizontal axis.

5. The assembly of claim 3, wherein first and second pivot member coupled to the video display unit are positioned through the carrier member so as to define the pivot axis and pivotably secure the video display unit to the carrier member.

6. The assembly of claim 1, wherein the receptacle member includes an outer lip and a plurality of outer skin capture members that engage with the outer skin such that the outer skin is extended over the outer lip of the receptacle member and secured to the outer skin capture members.

7. The assembly of claim 6, wherein the plurality of capture members define a pointed surface that engages with the outer skin and inhibits removal of the outer skin from the opening defined by the receptacle member.

8. The assembly of claim 1, further comprising a screen cover that is dimensioned to cover the video display unit, and wherein the cover is selectively disengagable so as to allow visual access to the video display unit.

9. The assembly of claim 8, wherein the cover includes an impact attenuating material.

10. The assembly of claim 8, wherein the cover includes a generally rigid layer to provide physical protection of the video display unit.

11. The assembly of claim 1, wherein the receptacle member has four sidewalls.

12. The assembly of claim 1, wherein the carrier member has four sidewalls.

13. The assembly of claim 1, wherein the edges of the outer skin are secured to each of the plurality of sidewalls.

14. A headrest assembly for a vehicle seat, the assembly comprising:

a receptacle member having a plurality of sidewalls that are joined to a back wall so as to define an opening wherein the receptacle member is adapted to be positioned in a back of the vehicle seat wherein the opening is facing away from the back of the vehicle seat when the receptacle member is positioned within the back of the vehicle seat and wherein the back wall of the receptacle member defines at least one securing aperture;

a carrier member having a plurality of sidewalls and a back wall so as to define an opening, wherein the opening in the carrier member is facing away from the back of the vehicle seat when the carrier member is positioned within the receptacle member and wherein the back wall of the carrier member defines at least one securing aperture;

an outer skin having edges that extend into the opening of the receptacle member and secured to at least some of the plurality of sidewalls of the receptacle member, and wherein the edges of the outer skin are substantially concealed when the carrier member is positioned within the opening of the receptacle member;

at least one fastener that extends through the at least one securing aperture of the carrier member and engages with the at least one securing aperture of the receptacle member to allow securing of the carrier member in the opening of the receptacle member;

a video display unit that is sized so as to be positioned within the opening in the carrier member and substantially conceal the at least one fastener when in a viewing orientation.

EXHIBIT C



(12) **United States Patent**
Tuccinardi et al.

(10) **Patent No.:** US 7,597,393 B1
 (45) **Date of Patent:** Oct. 6, 2009

(54) **HEADREST/HEAD RESTRAINT HAVING AN INTEGRATED VIDEO SCREEN**

3,258,511 A 6/1966 McGregor
 3,615,188 A 10/1971 Buxton

(76) Inventors: **Eugene M. Tuccinardi**, 28296 Corte Ocaso, Temecula, CA (US) 92592; **Ernesto R. Haack**, 26935 Spring St., Perris, CA (US) 92570; **Robert Murphy**, Lake Elsinore, CA (US); **Shanna Murphy**, legal representative, 16450 Pinyon St., Lake Elsinore, CA (US) 92530; **Frank Barrese**, 30170 Corte Coehlo, Temecula, CA (US) 92591; **Roel C. Espina**, 106 W. Pennsylvania Ave., # 912, Redlands, CA (US) 92374; **Jon A. Molo**, 31122 Dog Leg Cir., Temecula, CA (US) 92591; **Theo Zoetemelk**, 6408 Heather Wood Dr., Riverside, CA (US) 92509

(Continued)
 FOREIGN PATENT DOCUMENTS
 DE 3637772 A1 5/1988

(Continued)
 OTHER PUBLICATIONS
 Office Action of Aug. 2, 2006 for U.S. Appl. No. 11/415,696.

(Continued)
 Primary Examiner—Sarah McPartlin
 (74) Attorney, Agent, or Firm—Knobbe, Martens, Olson & Bear, LLP

(*) Notice: Subject to any disclaimer, the term of this patent is extended or adjusted under 35 U.S.C. 154(b) by 487 days.

(57) **ABSTRACT**

A seat back video display assembly adapted to be positioned in the back of a vehicle seat having an outer skin cover. In one aspect, the assembly may comprise a receptacle member having sidewalls and a back wall so as to define an opening wherein the receptacle member is adapted to be positioned in the back of the vehicle seat. In addition, the assembly may further comprise a carrier member having sidewalls and a back wall so as to define an opening, wherein the carrier member includes at least one fastener that extends from the back wall of the carrier member and engages with the back wall of the receptacle member to secure the carrier member into the receptacle member. Moreover, the assembly may still further comprise a video display unit that is sized so as to be positioned secured within the opening in the carrier member, wherein the video display unit provides video signals.

(21) Appl. No.: 10/819,341

(22) Filed: Apr. 5, 2004

Related U.S. Application Data

(60) Provisional application No. 60/460,841, filed on Apr. 4, 2003.

(51) **Int. Cl.**
 A47C 7/42 (2006.01)

(52) **U.S. Cl.** 297/217.3; 297/188.04

(58) **Field of Classification Search** 297/217.3, 297/188.4, 188.07

See application file for complete search history.

(56) **References Cited**

U.S. PATENT DOCUMENTS

3,004,815 A 10/1961 O’Kain et al.

15 Claims, 25 Drawing Sheets

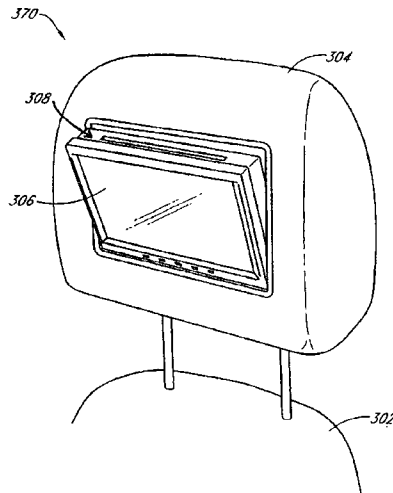

US 7,597,393 B1

Page 2

U.S. PATENT DOCUMENTS

4,525,746 A 6/1985 Mangold et al.
 4,584,603 A 4/1986 Harrison
 4,635,110 A 1/1987 Weinblatt
 4,647,980 A 3/1987 Steventon et al.
 4,681,366 A 7/1987 Lobanoff
 4,726,621 A 2/1988 Muller
 4,756,528 A 7/1988 Umashankar
 4,776,739 A 10/1988 Hamman
 4,788,588 A 11/1988 Tomita
 4,843,477 A 6/1989 Mizutani et al.
 4,860,415 A 8/1989 Witzke
 4,866,515 A 9/1989 Tagawa et al.
 RE33,423 E 11/1990 Lobanoff
 4,983,951 A 1/1991 Igarashi et al.
 5,168,615 A 12/1992 Koa
 5,267,775 A 12/1993 Nguyen
 5,292,174 A 3/1994 Ohnuma
 5,293,244 A 3/1994 Kawaguchi
 5,295,732 A 3/1994 Boisset
 5,311,302 A 5/1994 Berry et al.
 5,333,416 A 8/1994 Harris et al.
 5,359,349 A 10/1994 Jambor et al.
 5,507,556 A 4/1996 Dixon
 5,529,265 A 6/1996 Sakurai
 5,555,466 A 9/1996 Scribner et al.
 5,640,297 A 6/1997 Labaze
 5,713,633 A 2/1998 Lu
 D398,921 S 9/1998 Rosen
 5,842,715 A 12/1998 Jones
 5,946,055 A 8/1999 Rosen
 5,953,784 A 9/1999 Suzuki
 6,024,027 A 2/2000 Esmaili
 6,055,478 A * 4/2000 Heron 701/213
 D434,400 S 11/2000 Rosen
 6,199,948 B1 3/2001 Bush et al.
 6,216,927 B1 4/2001 Meritt
 6,250,967 B1 6/2001 Chu
 D448,009 S 9/2001 Lavelle
 6,292,236 B1 9/2001 Rosen
 6,305,046 B1 10/2001 Kingry
 6,339,455 B1 1/2002 Allan et al.
 6,394,551 B1 5/2002 Beukema
 6,406,334 B2 6/2002 Chu
 6,409,242 B1 6/2002 Chang
 6,450,571 B1 9/2002 Canni
 6,480,243 B2 11/2002 Yamamoto
 6,522,368 B1 2/2003 Tuccinardi et al.
 6,669,285 B1 12/2003 Park et al.
 6,739,654 B1 5/2004 Shen et al.
 6,750,599 B2 6/2004 Tajima
 6,755,491 B2 6/2004 McElheney
 6,762,929 B2 * 7/2004 Sawyer 361/681
 6,786,547 B1 9/2004 Chu

6,871,356 B2 3/2005 Chang
 6,883,870 B2 4/2005 Jost
 6,899,365 B2 5/2005 Lavelle
 6,986,190 B2 1/2006 Jost
 7,036,879 B2 5/2006 Chang
 7,038,581 B2 * 5/2006 Kendall et al. 340/506
 7,040,697 B1 5/2006 Tuccinardi et al.
 7,044,546 B2 * 5/2006 Chang 297/217.3
 7,188,895 B1 3/2007 Tuccinardi
 7,245,274 B2 7/2007 Schedivy
 7,407,227 B1 8/2008 Tuccinardi
 2001/0008266 A1 7/2001 Lambert
 2003/0025367 A1 2/2003 Boudinot
 2004/0007906 A1 1/2004 Park et al.
 2004/0032543 A1 2/2004 Chang
 2004/0160096 A1 8/2004 Boudinot
 2005/0099042 A1 * 5/2005 Vitito 297/217.3
 2005/0242638 A1 * 11/2005 Vitito 297/217.3
 2007/0001492 A1 * 1/2007 Chang 297/217.3
 2007/0102973 A1 * 5/2007 Vitito 297/217.3

FOREIGN PATENT DOCUMENTS

DE 19601582 A1 1/1996
 FR 2764563 A1 12/1998
 JP 01094048 A 4/1989
 WO WO 02/074577 A1 9/2002

OTHER PUBLICATIONS

Response to Office Action for Aug. 2, 2006 for U.S. Appl. No. 11/415,696.
 Final Office Action of Mar. 13, 2007 for U.S. Appl. No. 11/415,696.
 RCE & Response to Final Office Action of Mar. 13, 2007 for U.S. Appl. No. 11/415,696.
 Office Action of Aug. 31, 2007 for U.S. Appl. No. 11/415,696.
 Response to Office Action of Aug. 31, 2007 for U.S. Appl. No. 11/415,696.
 Office Action of Jan. 31, 2007 for U.S. Appl. No. 11/415,918.
 Response to Office Action of Jan. 31, 2007 for U.S. Appl. No. 11/415,918.
 Final Office Action of Jul. 30, 2007 for U.S. Appl. No. 11/415,918.
 RCE and Response to Final Office Action of Jul. 30, 2007 for U.S. Appl. No. 11/415,918.
 Restriction Requirement of Jul. 19, 2004 for U.S. Appl. No. 10/395,870.
 Response to Restriction Requirement of Jul. 19, 2004 for U.S. Appl. No. 10/395,870.
 Office Action of Sep. 27, 2004 for U.S. Appl. No. 10/395,870.
 Response to Office Action of Sep. 27, 2004 for U.S. Appl. No. 10/395,870.
 Final Office Action of May 3, 2005 for U.S. Appl. No. 10/395,870.
 RCE & Response to Final Office Action of May 3, 2005 for U.S. Appl. No. 10/395,870.
 Notice of Allowance of Dec. 6, 2005 for U.S. Appl. No. 10/395,870.

* cited by examiner

U.S. Patent

Oct. 6, 2009

Sheet 1 of 25

US 7,597,393 B1

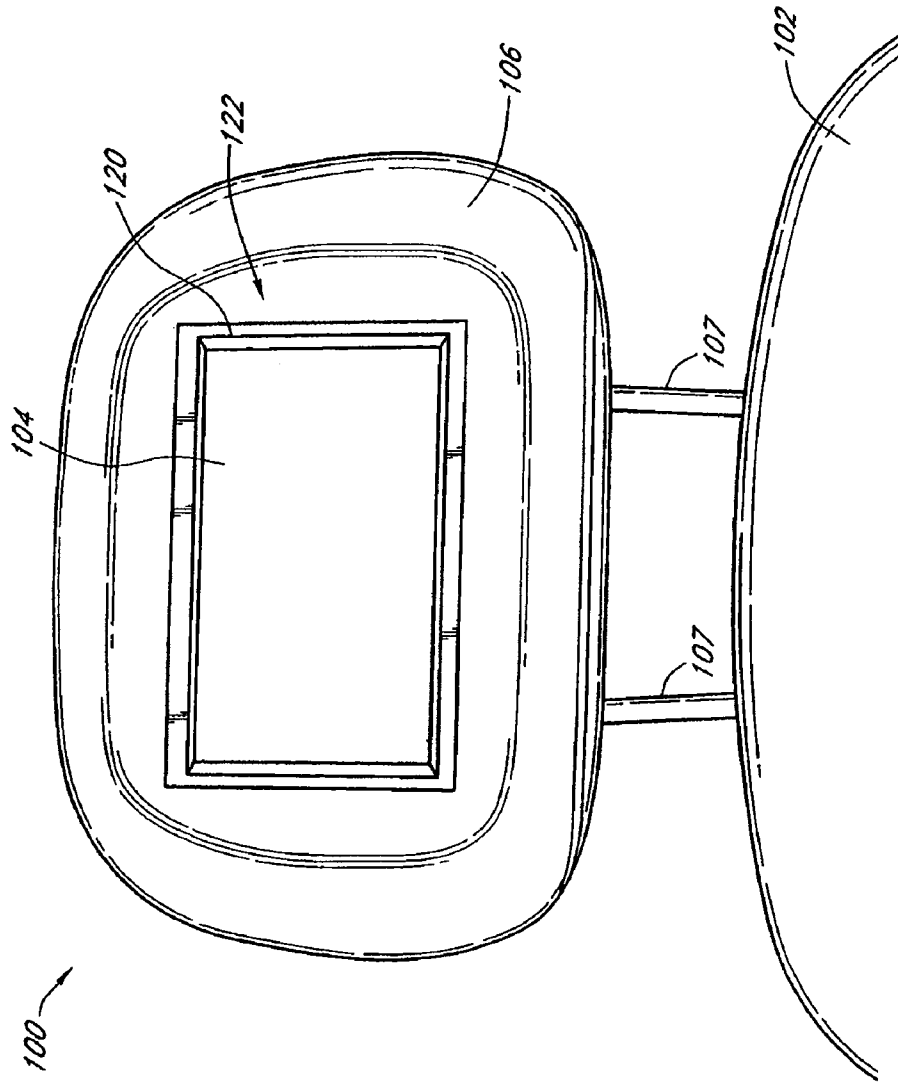

FIG. 1A

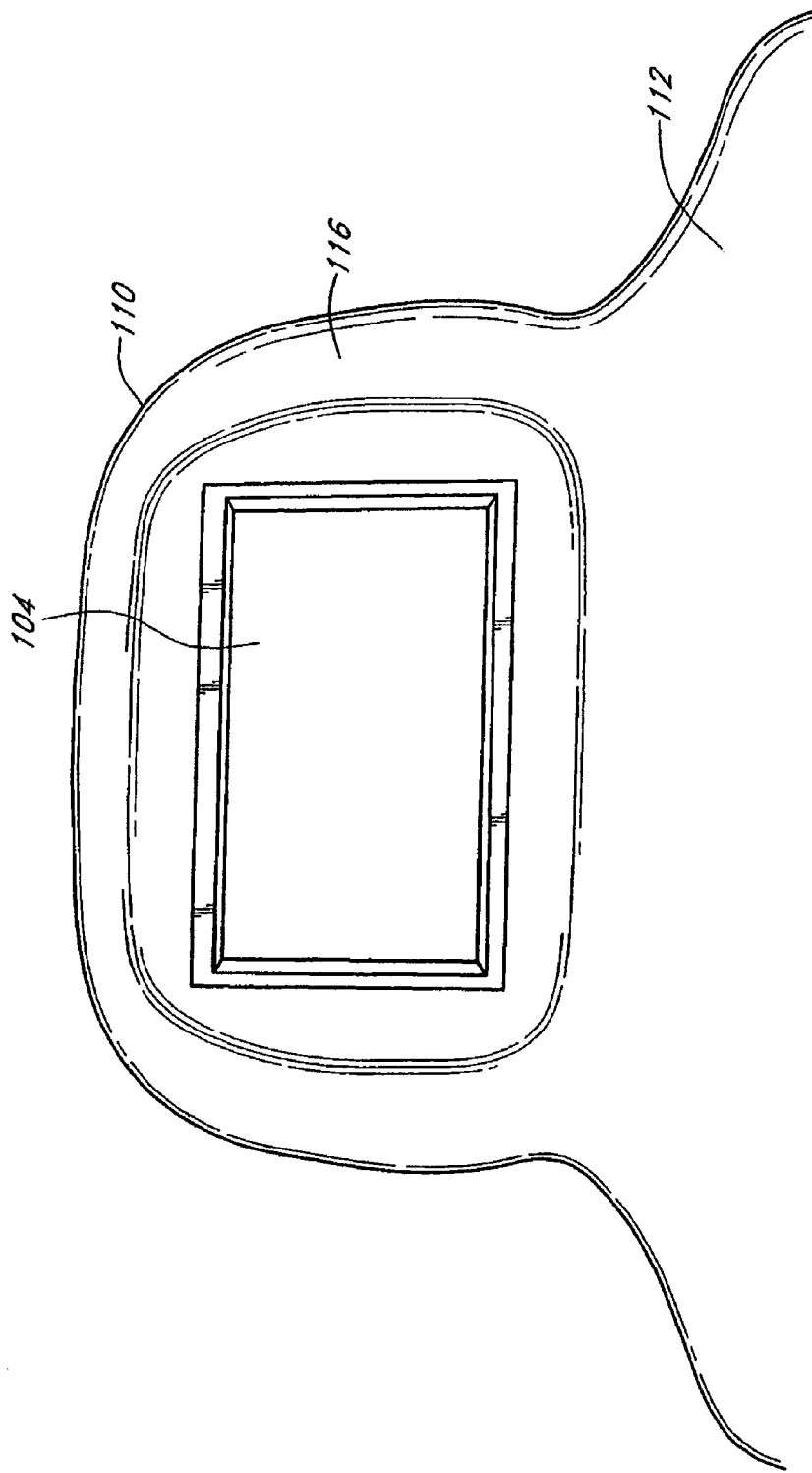

FIG. 1B

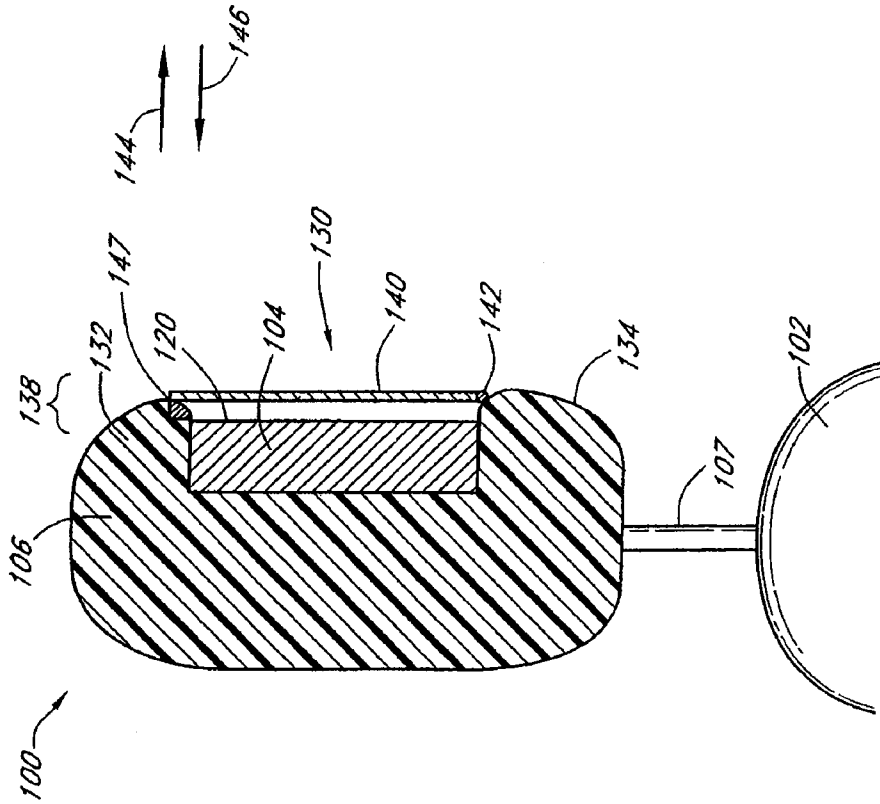

FIG. 3A

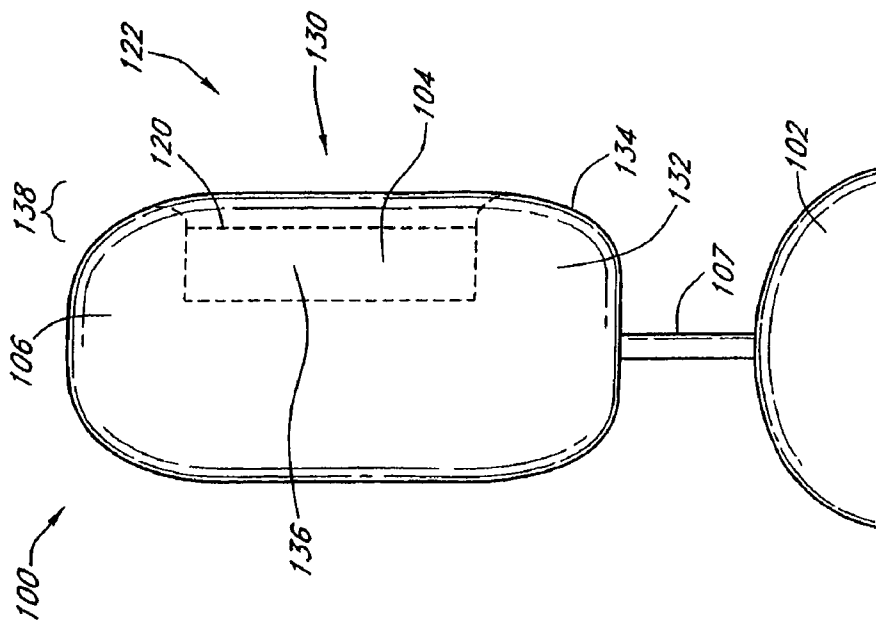
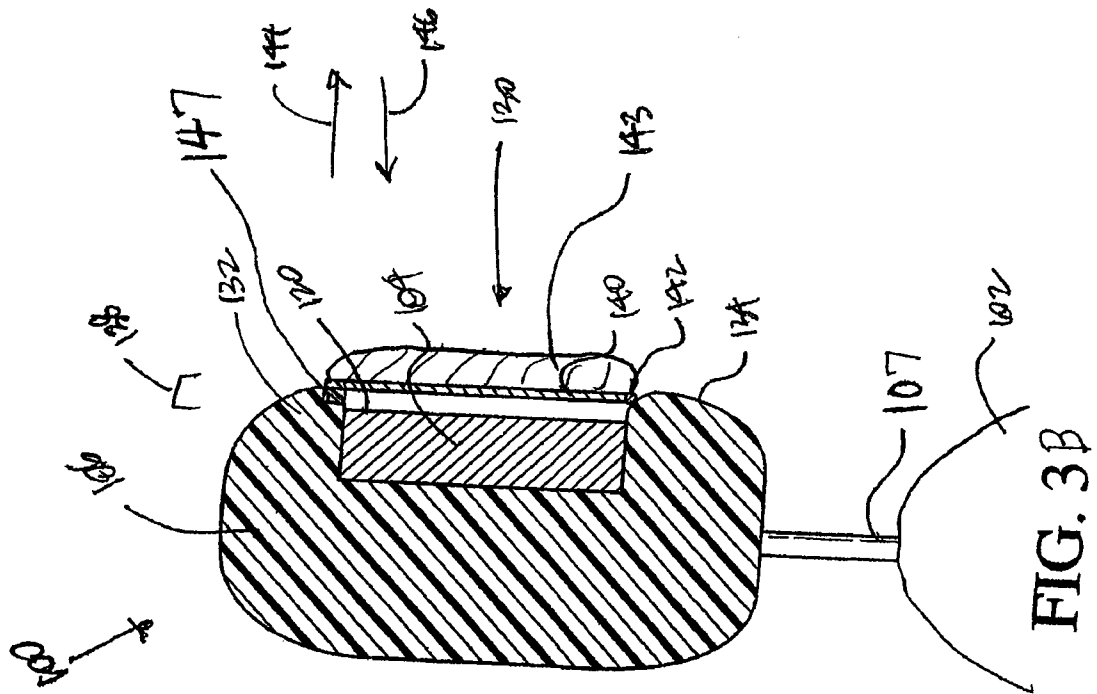

FIG. 2



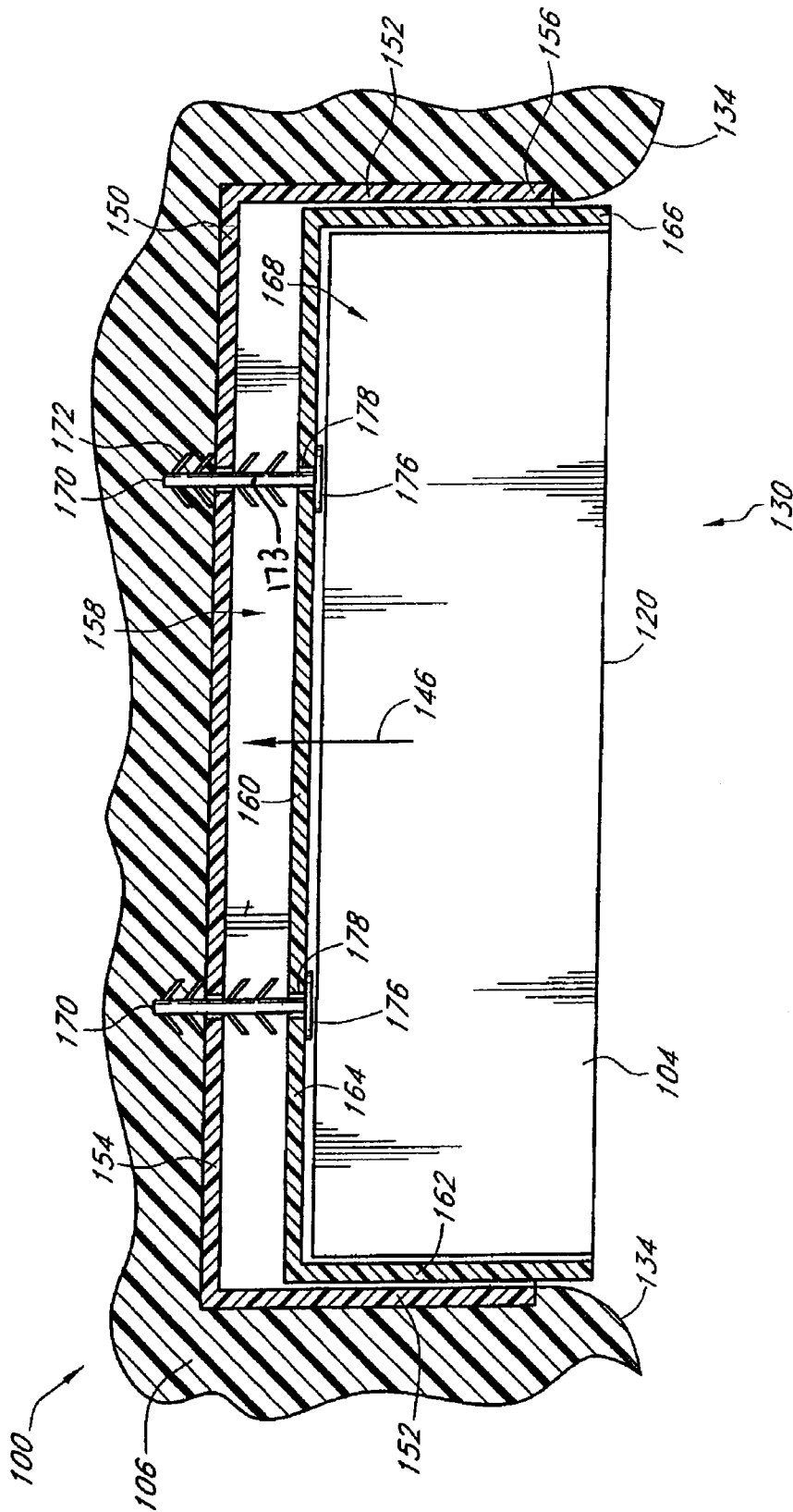
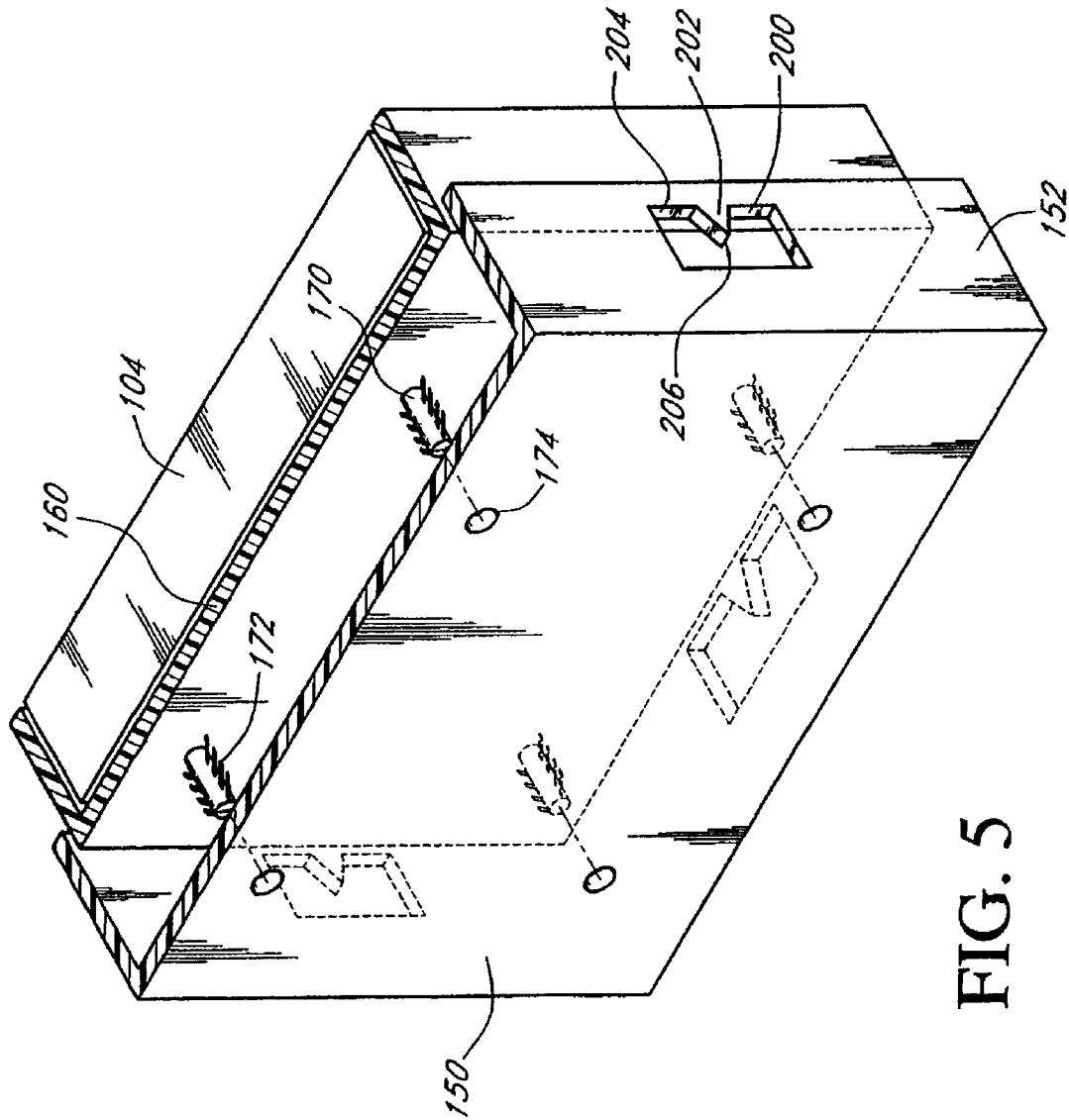

FIG. 4



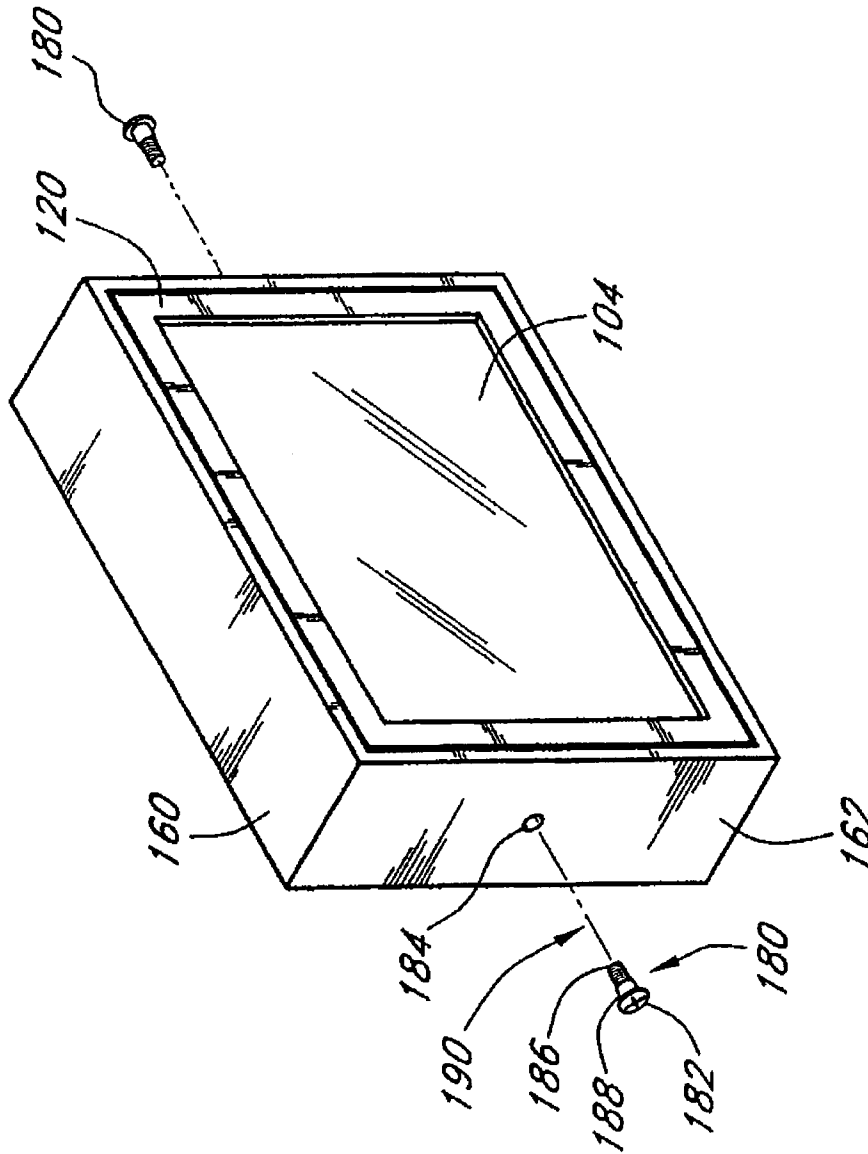

FIG. 6A

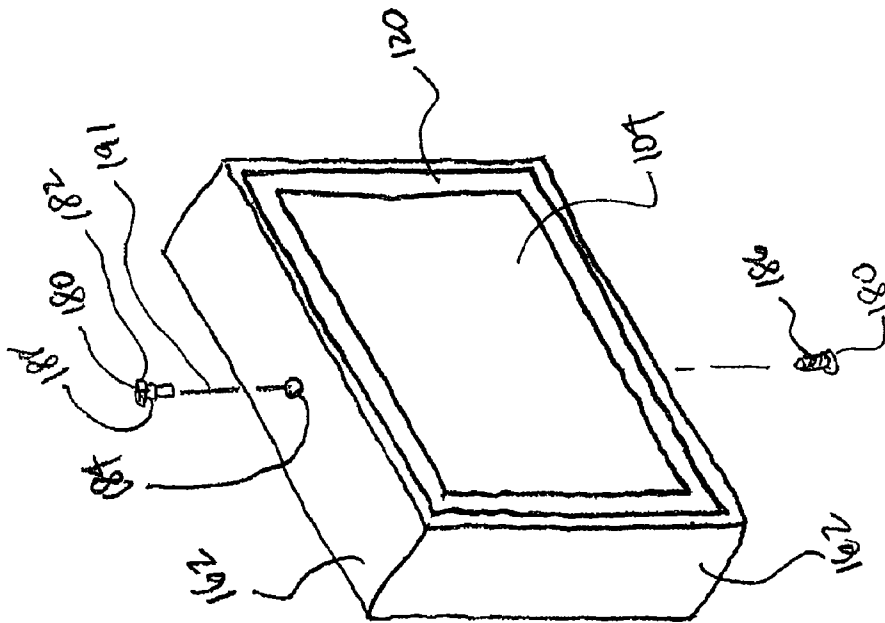
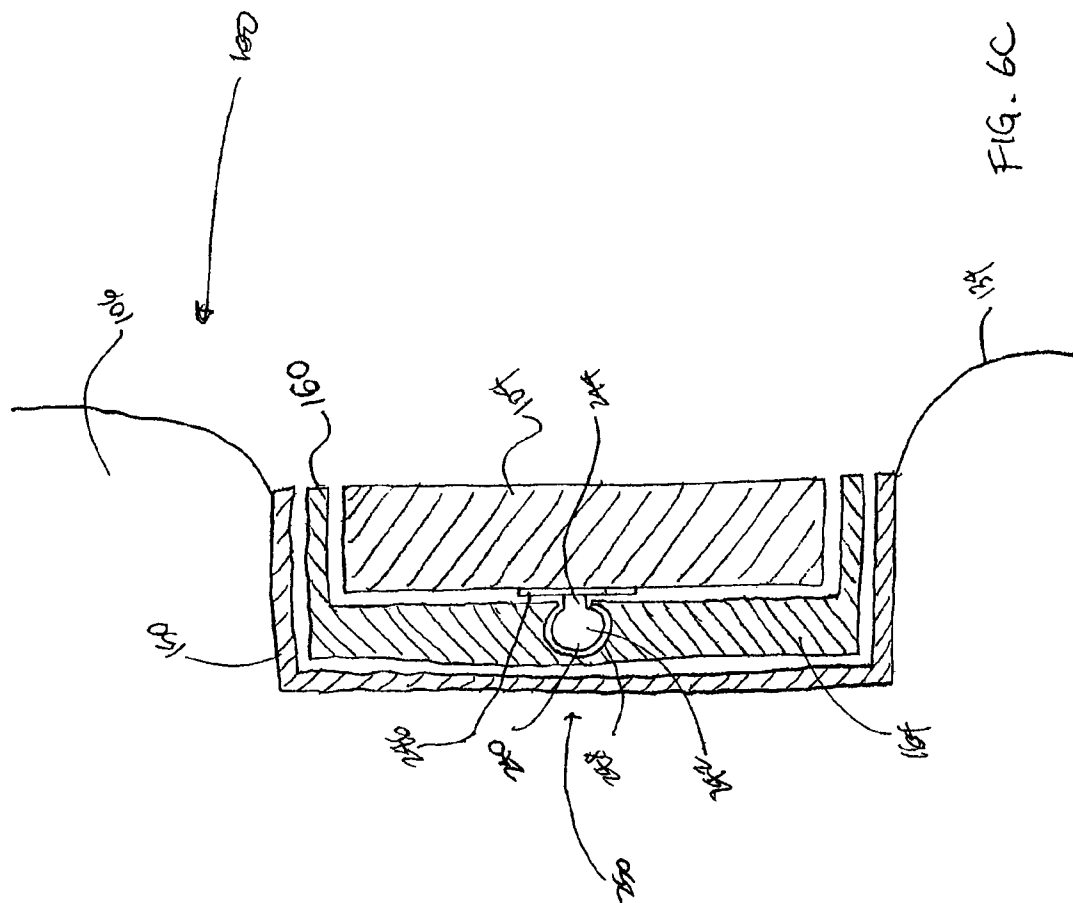

FIG. 6B



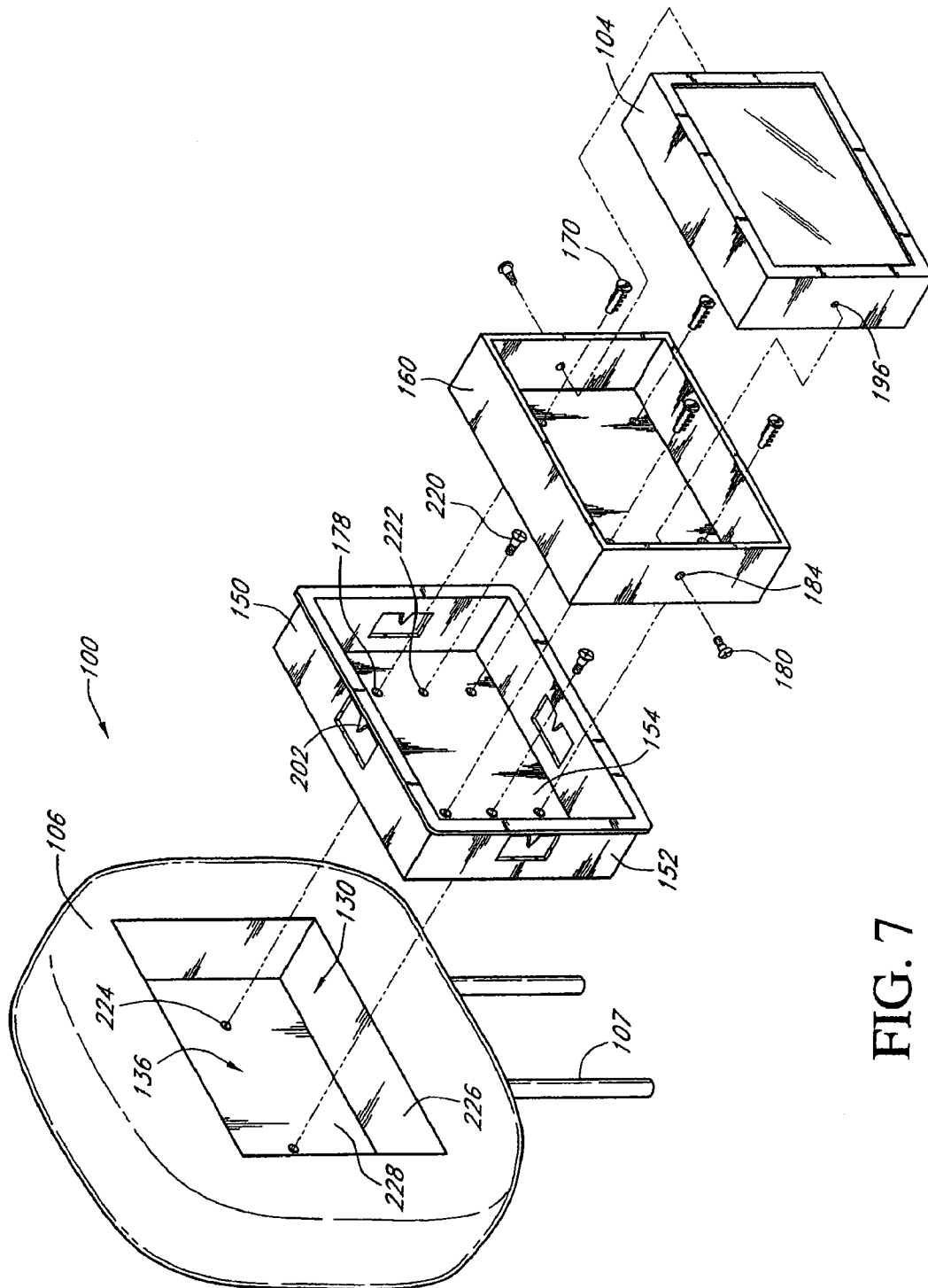

FIG. 7

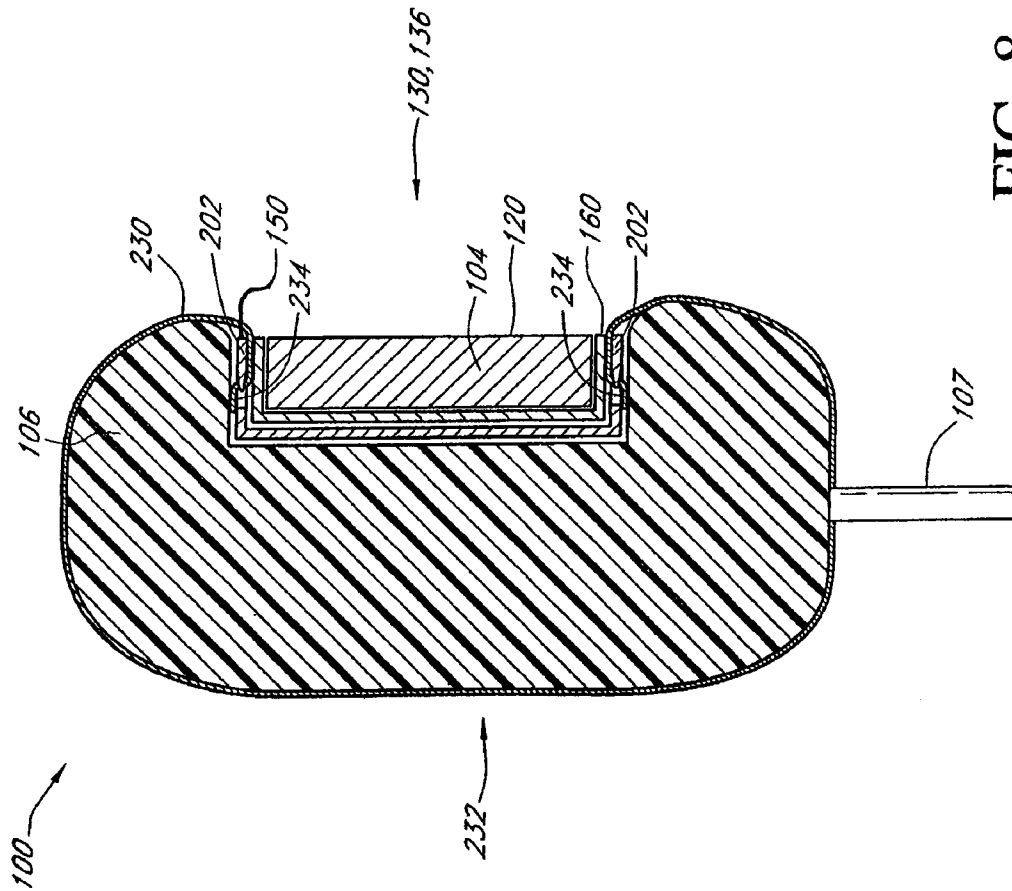

FIG. 8

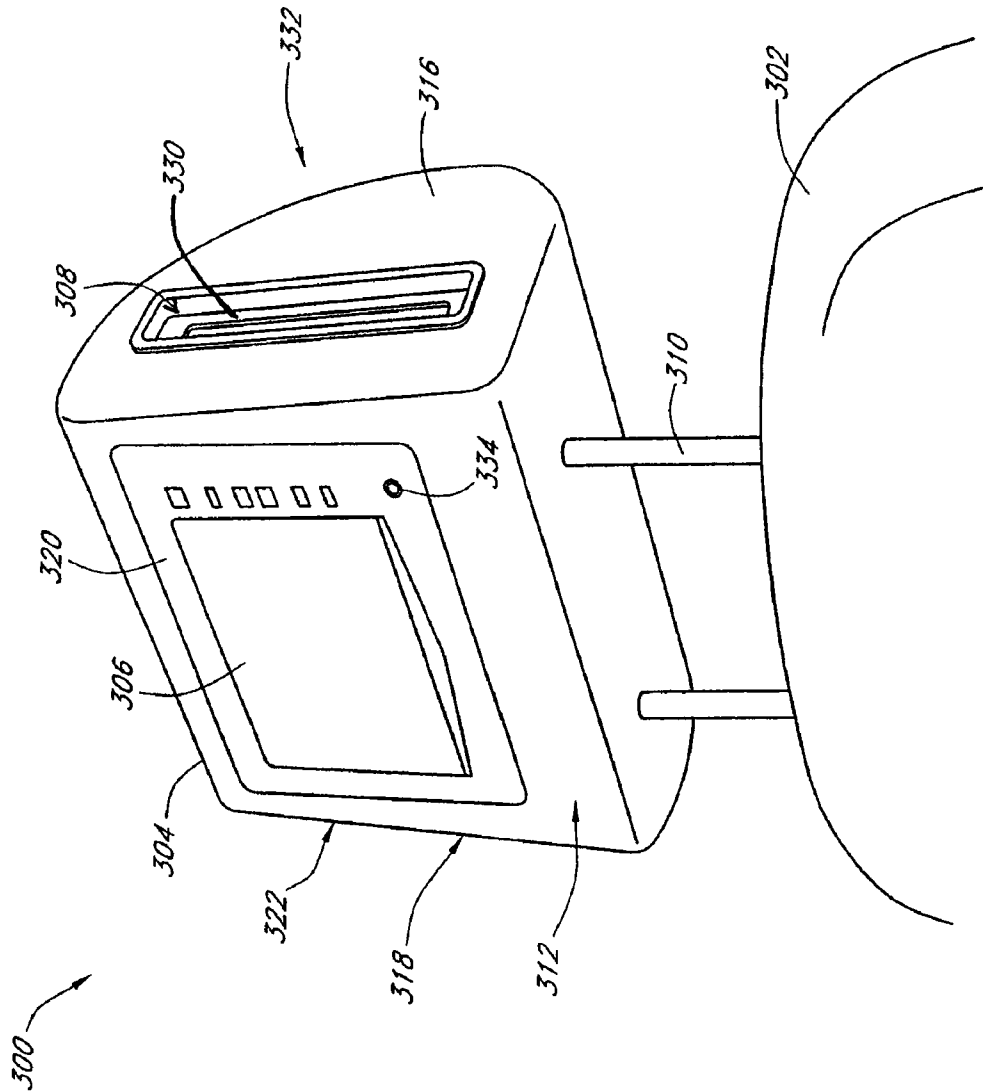

FIG. 9A

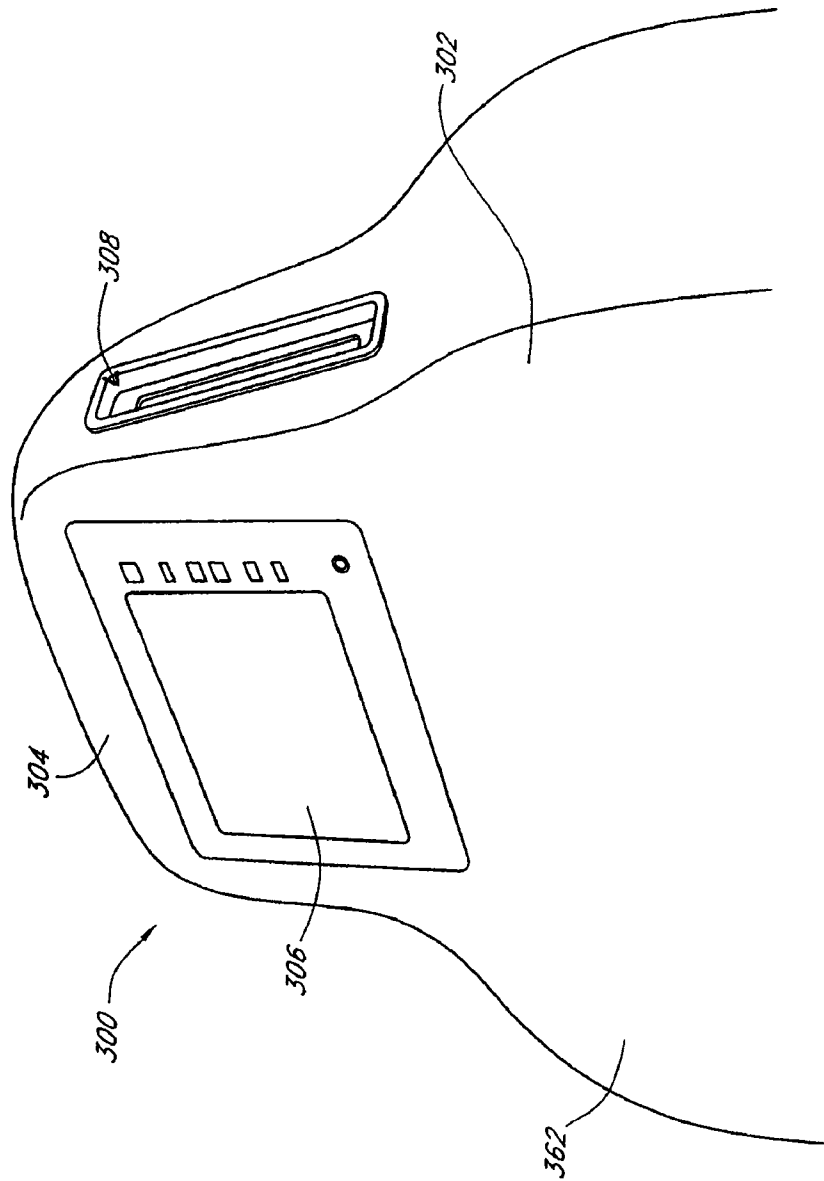

FIG. 9B

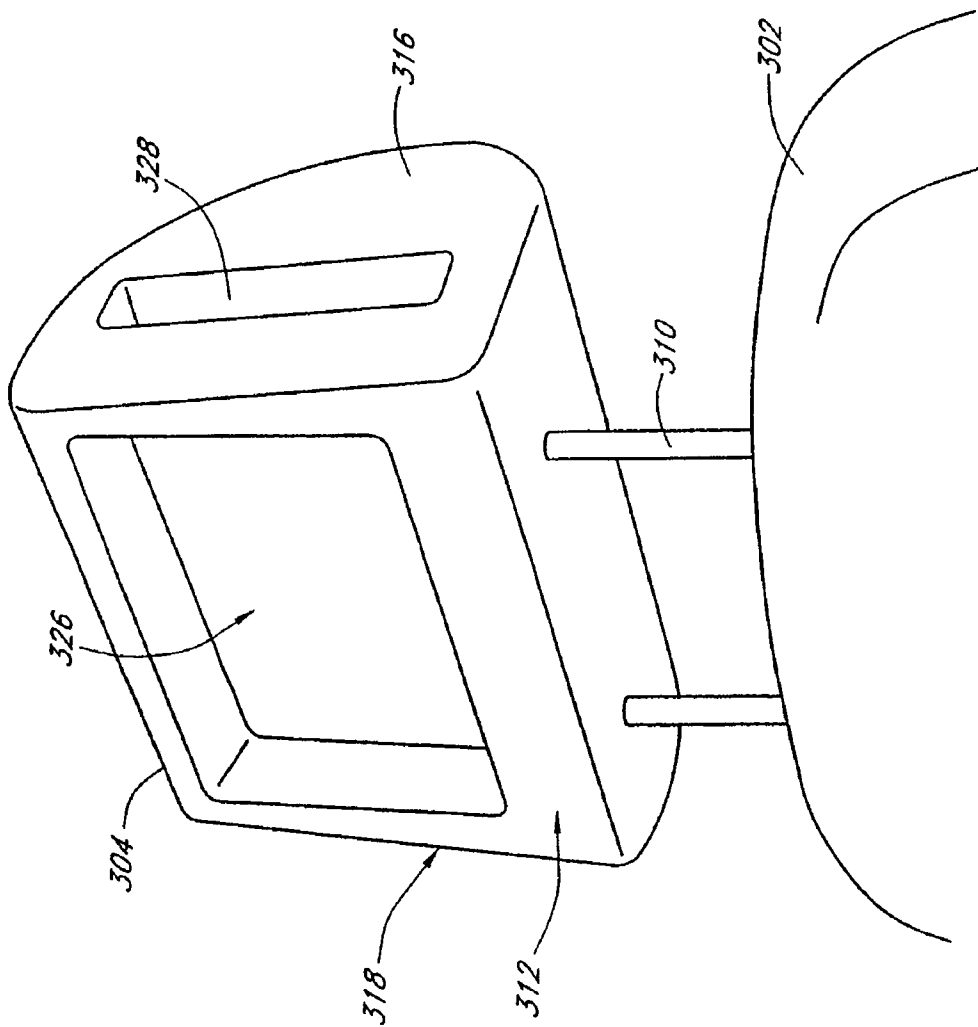

FIG. 9C

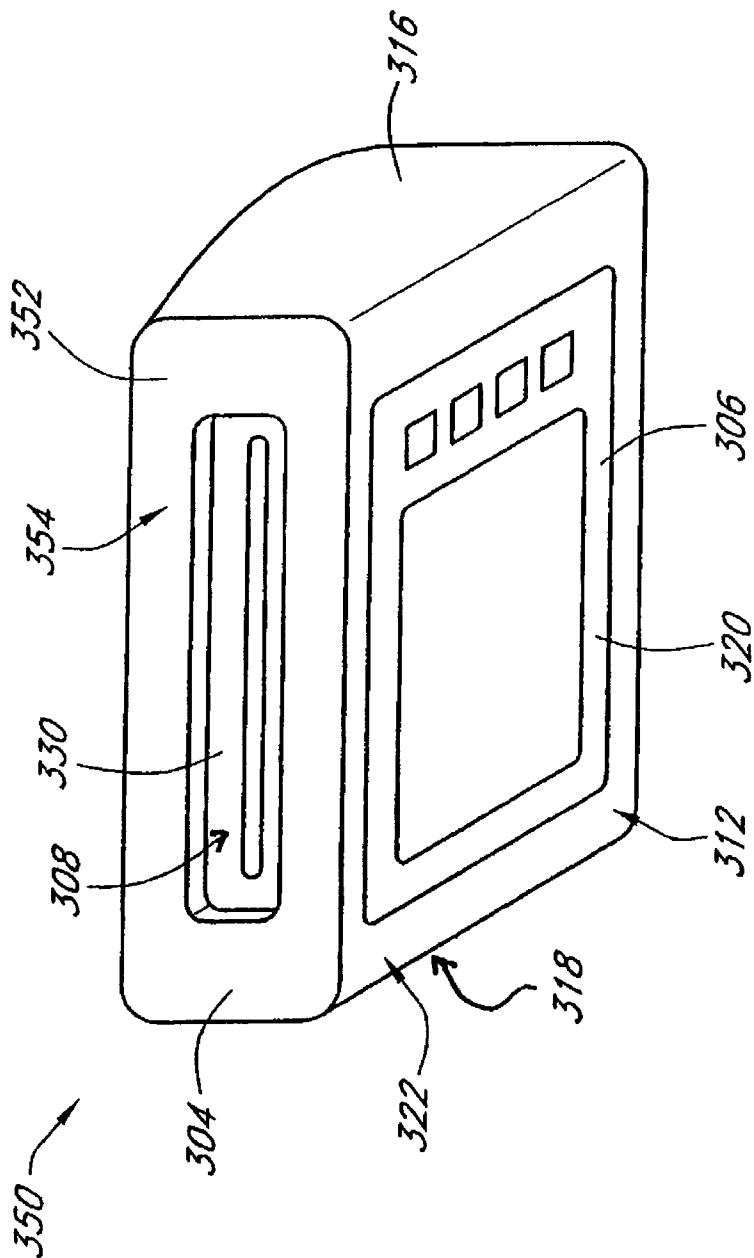

FIG. 10

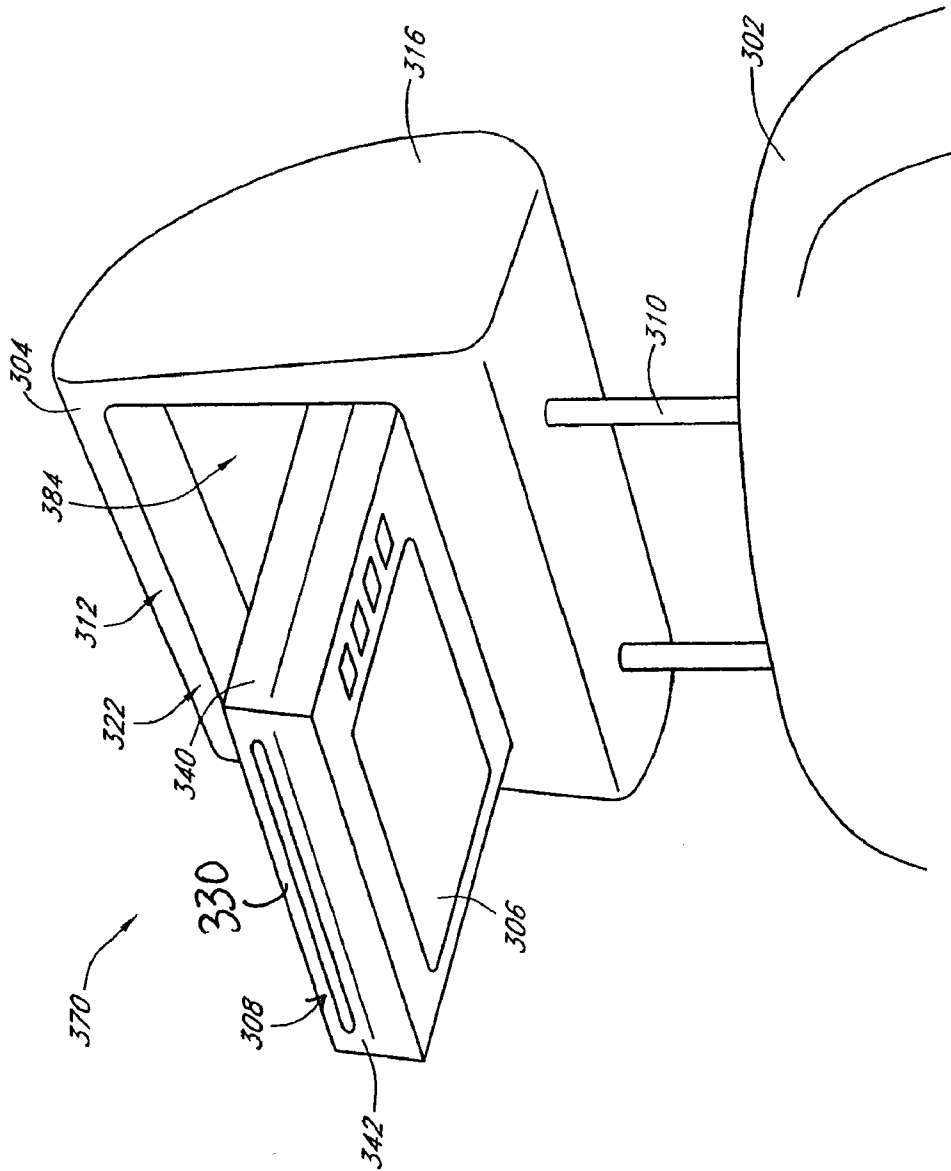

FIG. 11A

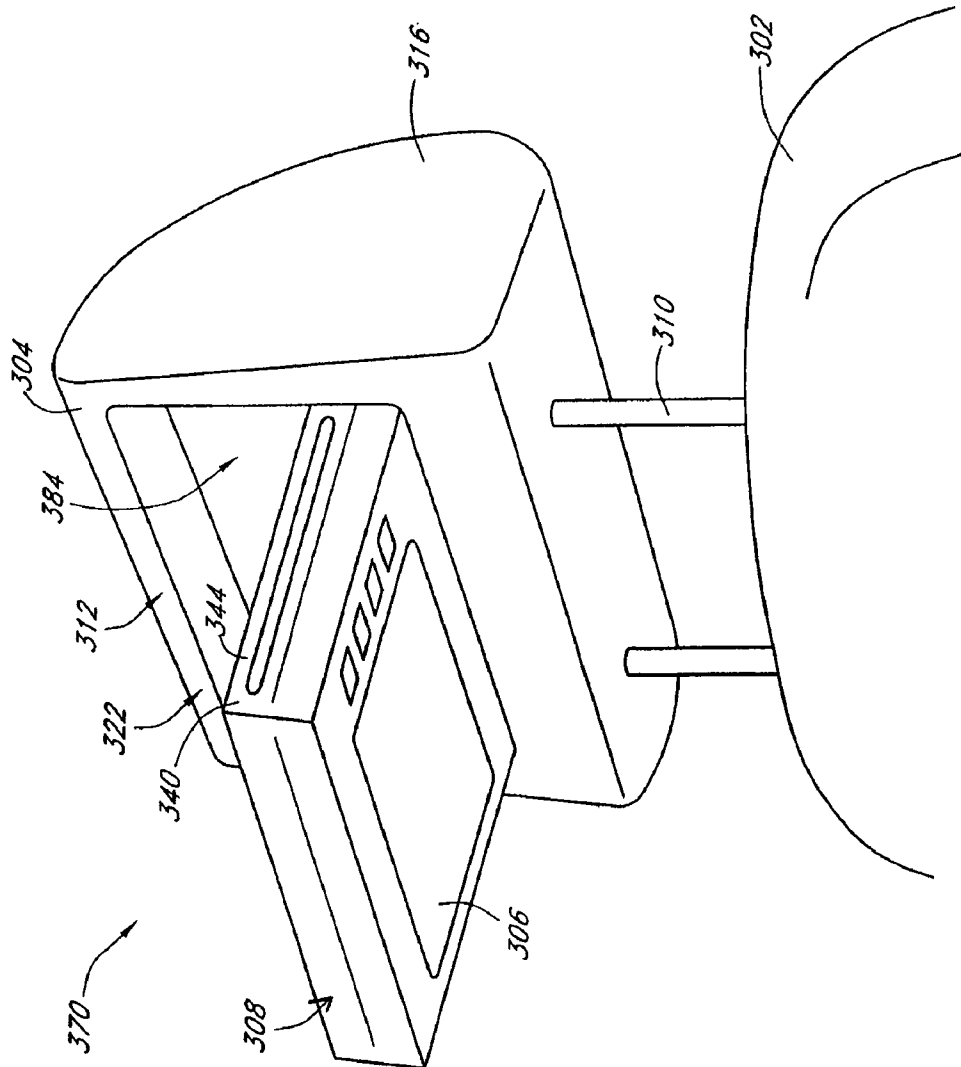

FIG. 11B

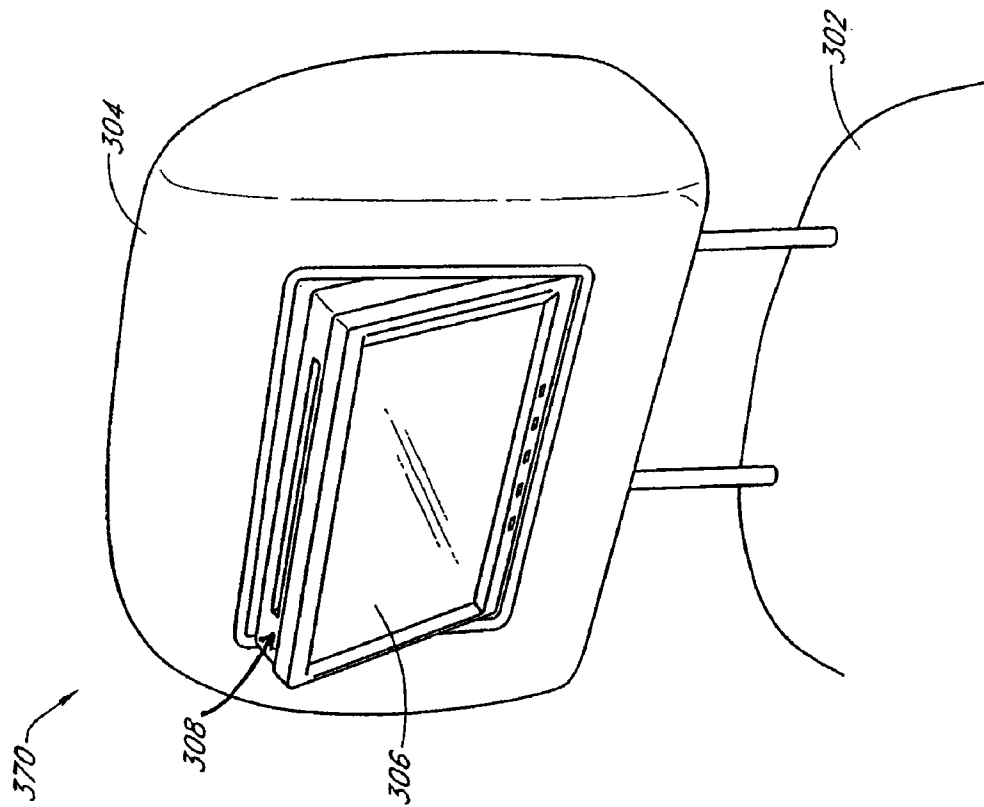

FIG. 11C

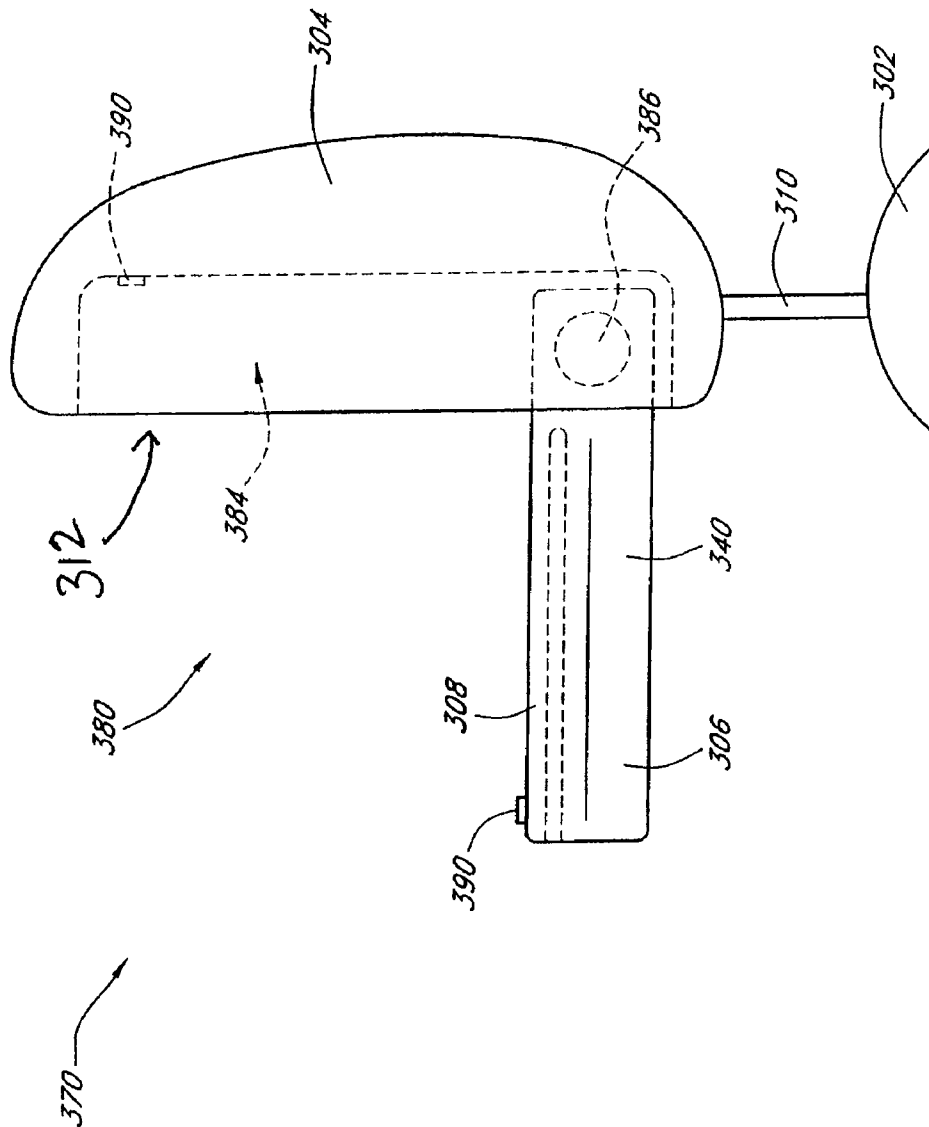

FIG. 12A

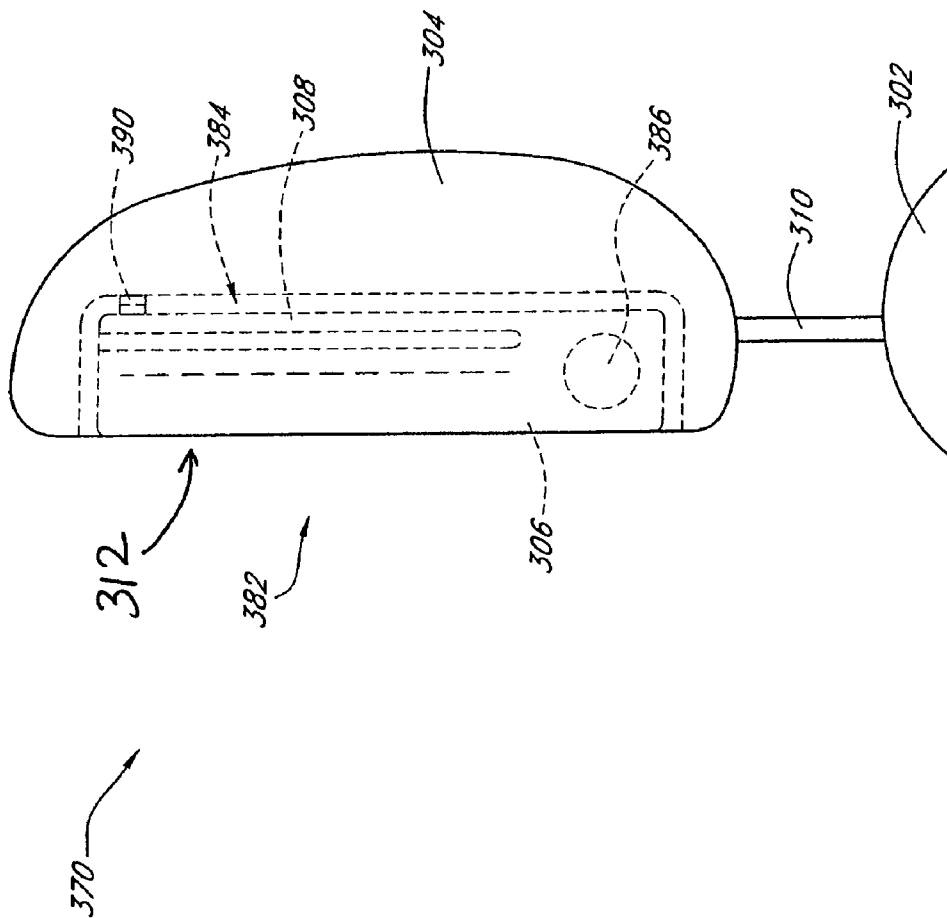

FIG. 12B

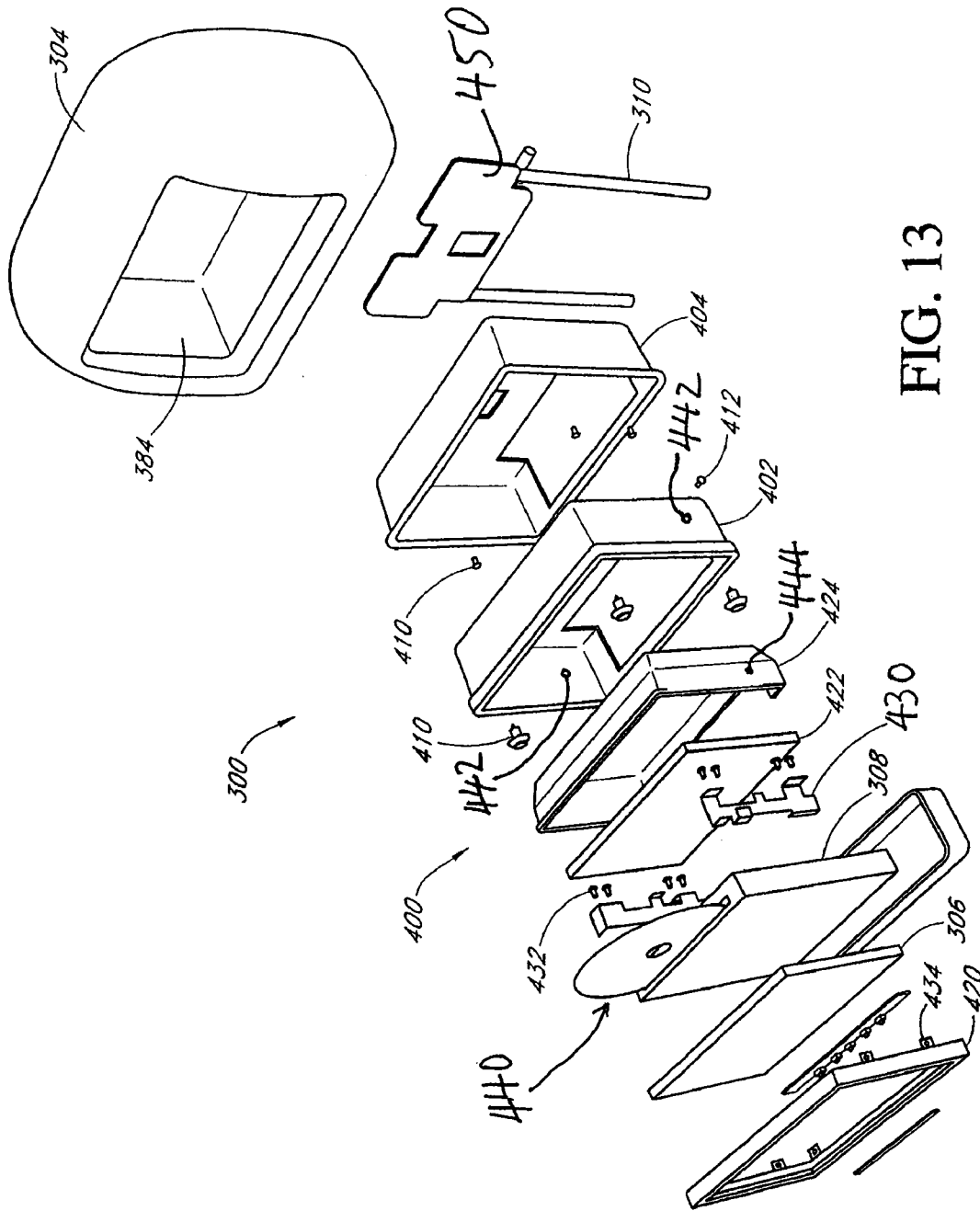
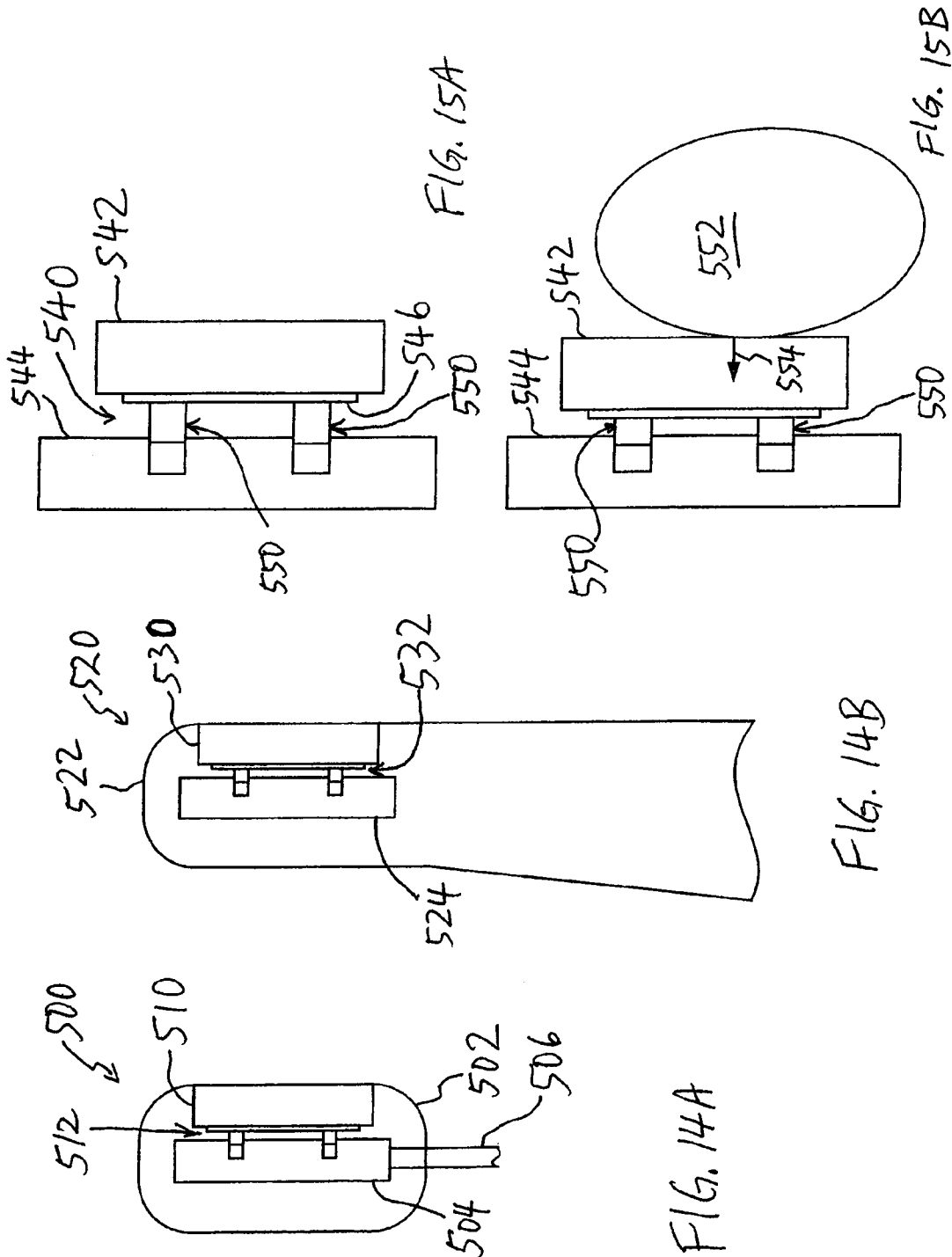

FIG. 13



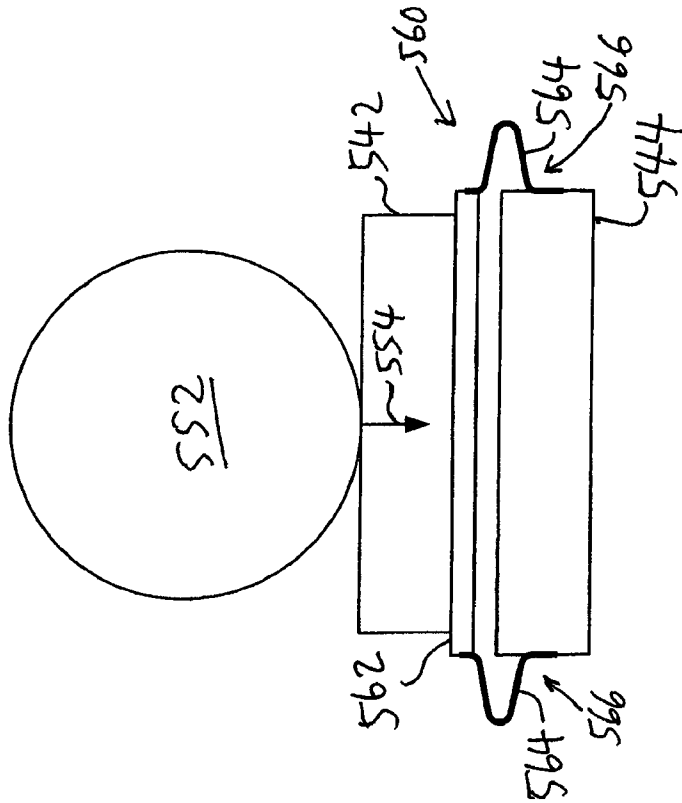

FIG. 16B

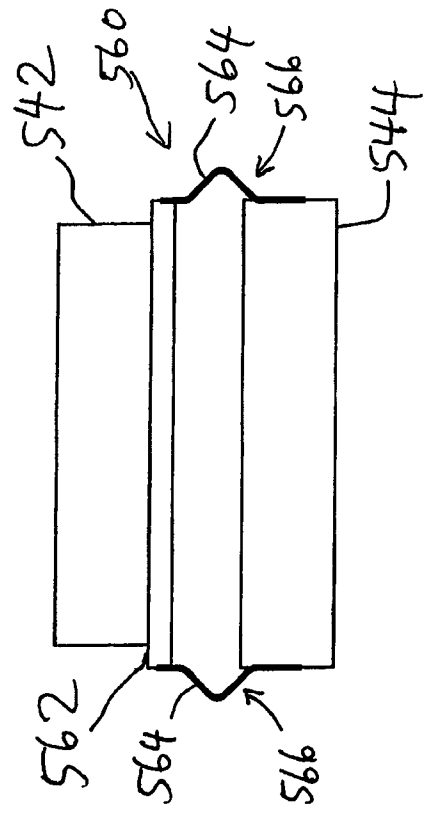

FIG. 16A

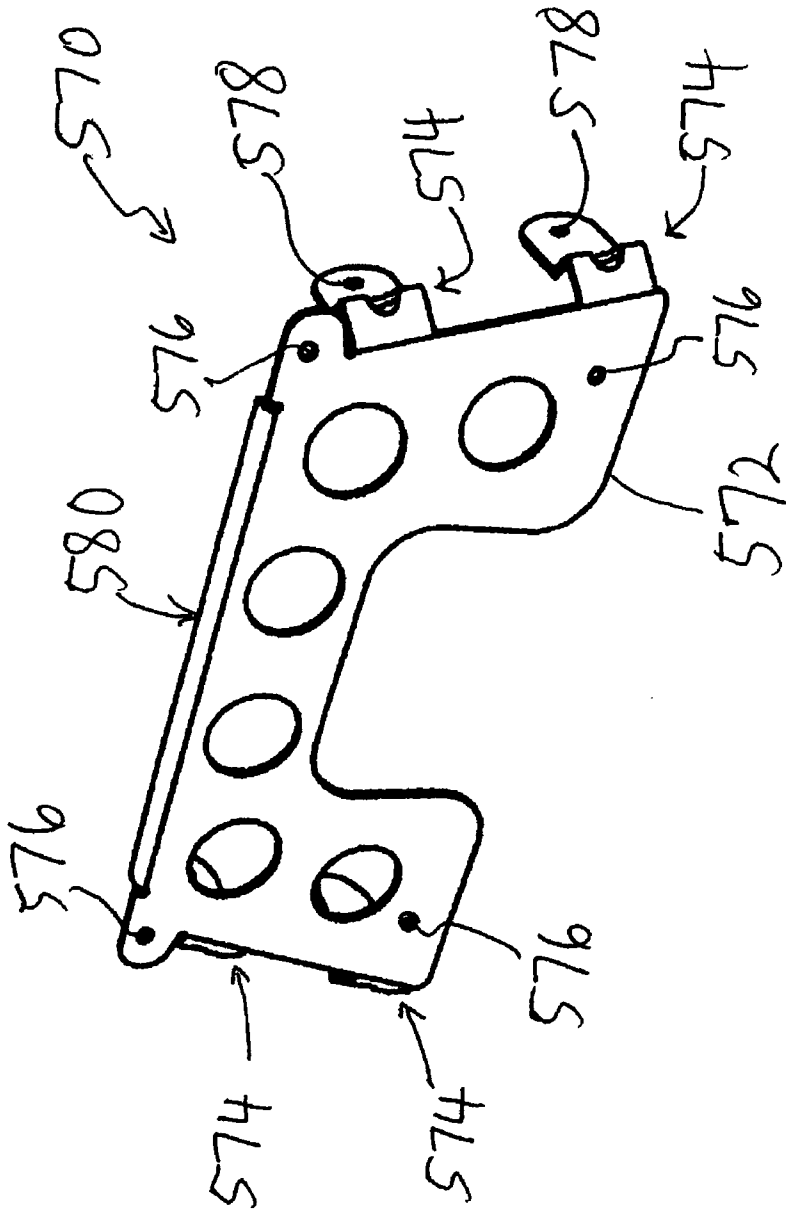
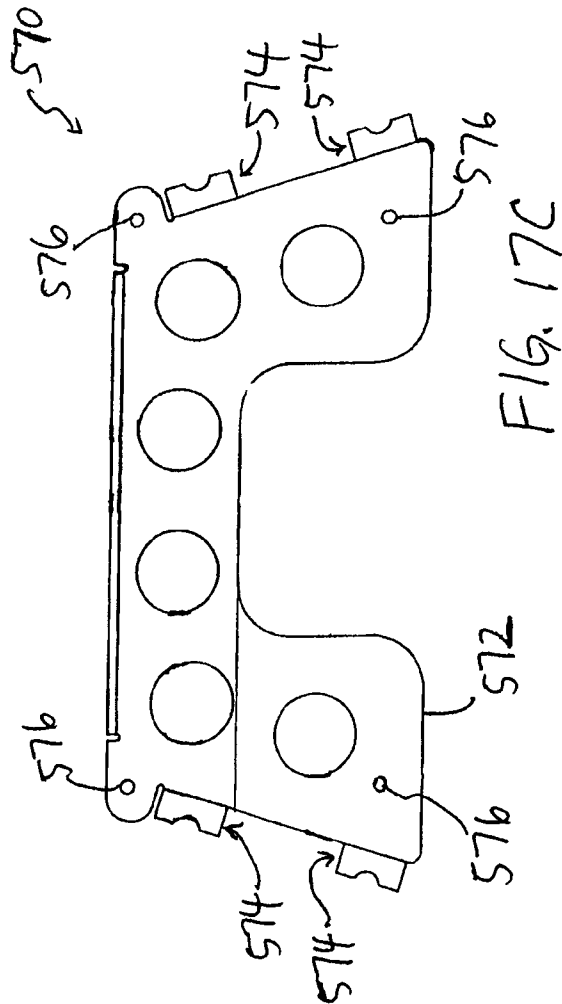
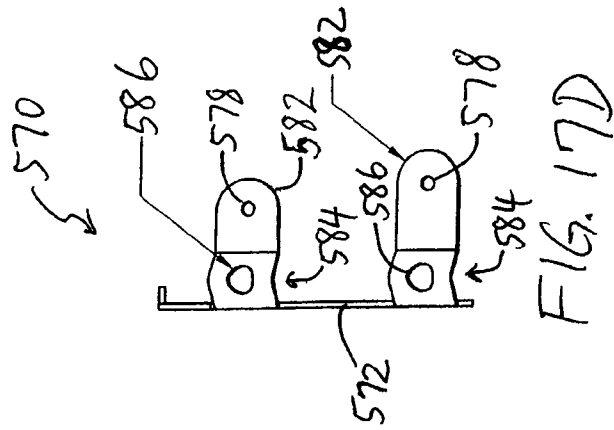
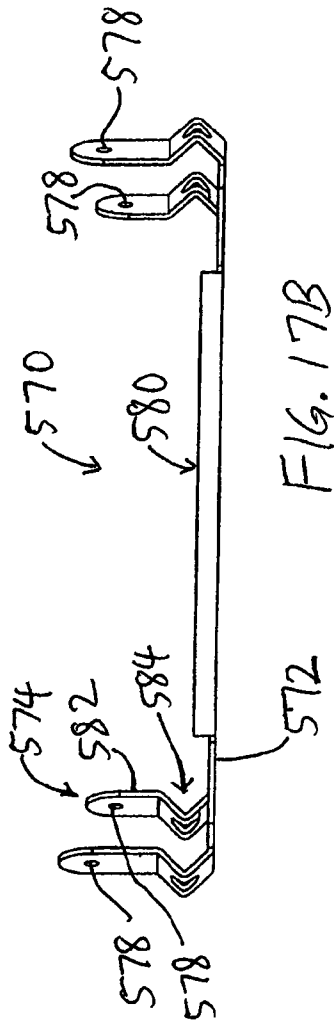

FIG. 17A



US 7,597,393 B1

1

**HEADREST/HEAD RESTRAINT HAVING AN
INTEGRATED VIDEO SCREEN**

CLAIM OF PRIORITY

This U.S. patent application is related to U.S. Pat. No. 7,040,697, filed Mar. 20, 2003, entitled, "Headrest Having An Integrated Video Screen" and co-pending patent application Ser. Nos. 11/415,696, filed May 2, 2006, entitled, "Headrest Having An Integrated Video Screen" and 11/415,918, filed May 2, 2006, entitled, "Headrest Having An Integrated Video Screen", which are hereby incorporated by reference herein in their entirety. This U.S. patent application also claims priority to U.S. Provisional Patent Application No. 60/460,841, entitled "Integrated Video System for Vehicle Seats" filed Apr. 4, 2003, which is hereby incorporated by reference herein in its entirety.

BACKGROUND OF THE INVENTION

1. Field of the Invention

The present invention relates to vehicles and, in particular, to a head restraint for vehicle seats having an integrated video screen mounted therein.

2. Description of the Related Art

Seat back video monitors are becoming increasingly popular in vehicles. Originally, these entertainment systems were largely confined to airplanes, however, recently, these systems have become much more popular with cars, trucks and SUVs. These entertainment systems provide the opportunity for passengers to view entertainment or educational video programs during long trips.

Typically, these systems have been installed as aftermarket products where the seat back or head restraint, whether part of an adjustable head restraint unit or a molded bucket seat, is modified to accept the video display device, however, more of these systems are being installed as original equipment. Unfortunately, existing systems are often difficult and labor intensive to mount, particularly as an aftermarket product and are also subject to being dislodged.

Generally, the devices are mounted on the outer surface of the seat back where they protrude. In many vehicles, the space between seats is limited, hence the protruding video display unit can inhibit the ability of passengers to easily get into and out of the vehicles. Moreover, passenger contact with the protruding video display screen may result in the screens being inadvertently dislodged, or result in occupant injury in a collision.

A further difficulty with many existing video display unit designs is that they are not well secured to the seat. This is particularly the case for designs that allow the video display unit to pivot about an axis to improve the viewing angle of the passenger. One common way that these display units are installed is that a bucket is installed into the seat and the peripheral rim of the bucket includes openings that receive pivot posts that extend outward from the housing of the display unit. The pivot posts are positioned within the openings and keepers or caps are then positioned in the openings to prevent the pivot posts from being removed from the openings.

In these designs, the keepers or caps are generally press fit and are exposed to the passenger. Hence, inadvertent contact may result in the keepers or caps being dislodged. Moreover, many of the passengers are children who, through boredom, may attempt to remove the keepers which can result in the video display being dislodged and potentially damaged.

2

Thus, one can see that improvements can be made on ways a video display screens or associated devices are mounted to various types of seats. Some of the areas where improvements can be made include safety issues associated with an occupant impacting the video display assembly, cosmetic integration of the video display assembly, and efficiency of packaging the video display assembly.

Hence, from the foregoing, there is a need for a seat back video display system and method of mounting that provides more secure mounting of the video display unit. To this end, there is a need for an assembly that is less likely to be dislodged through inadvertent contact and does not have exposed detachable mounting components.

SUMMARY OF THE INVENTION

The foregoing needs are addressed by the present teachings relating to a head restraint having an entertainment system. One aspect of the present teachings relates to a media assembly adapted to be installed into a seat back of a vehicle. The assembly includes a mounting structure that is coupled to the seat back of the vehicle. The seat back defines a first outer surface visible to a viewer sitting in a back seat of the vehicle. The assembly further includes a display that displays media to a viewer sitting within the vehicle. The assembly further includes a media player having an input opening into which a user can position a media storage device. The media player provides signals to the display to thereby induce the display to visually display the contents of the media storage device. The assembly further includes a housing defining a recess having a first opening that receives both the display and the media player such that the display is positioned proximate the first opening of the recess with the media player positioned inward in the recess from the first opening such that the media player does not impede visual access to the display. The housing is structured to permit selective access to the input opening of the media player to permit user positioning of the media storage device within the player. The housing is adapted to be coupled to the mounting structure within the seat back of the vehicle to thereby retain the housing within the seat back such that the display is positioned adjacent the outer surface of the seat back.

In one embodiment, the housing defines a second opening and the media player is positioned within the recess such that the input opening of the media player is accessible through the second opening of the housing. In one opening, the housing is mounted to the mounting structure such that the second opening is accessible through a second outer surface of the seat. In one embodiment, the second outer surface of the seat comprises a side surface of the seat. In one embodiment, the second outer surface of the seat comprises a top surface of the seat.

In one embodiment, the housing is pivotally mounted with respect to the mounting structure such that the display screen can be adjusted for improved visibility to the viewer. In one embodiment, the housing comprises a ball and the mounting structure comprises a socket such that the ball is positioned within the socket to permit adjustment of the housing with respect to the mounting structure in two separate directions.

In one embodiment, the housing is pivotally attached to the mounting structure so as to be rotatable between a recessed position. The display is positioned substantially flush with the first outer surface of the seat and the input opening of the media player is hidden from view within the seat and a extended position. The input opening of the media player is exposed from the seat so as to be accessible to the viewer. In one embodiment, the mounting structure comprises a retainer

US 7,597,393 B1

3

that defines a recess having two opposed side walls positioned within the seat. The housing is pivotally attached to the retainer at the two opposed side walls to facilitate movement between the recessed position and the extended position. In one embodiment, the retainer defines two opposed side walls and an opposed upper and lower wall. The housing is pivotally attached to the two opposed side walls adjacent the lower wall of the retainer such that the input opening of the media player is positioned proximate the upper wall of the retainer when the housing is in the recessed position.

In one embodiment, at least one energy dissipation element is interposed between the seat and the assembly such that in the event of a collision, contact between the viewer and the media assembly results in at least a portion of the energy resulting from the collision being dissipated by the at least one energy dissipation element. In one embodiment, the at least one energy dissipation element comprises a deformable dissipation element that dissipates the energy by inelastically deforming. In one embodiment, the at least one deformable dissipation element comprises a member that is structured to have a bending point along the member such that forces on the member during a collision result in the bending of the member and dissipation of force. In one embodiment, the member comprises a first and a second leg with the bending point interposed therebetween such that forces on the member during a collision result in the first member being deformed into a position more proximate the second member. In one embodiment, the energy dissipation element is interposed between the mounting structure and the seat.

Another aspect of the present teachings relates to an electronic assembly mounted to a head restraint of a vehicle seat. The assembly includes a media player that retrieves information stored on a media storage device, processes the information, and outputs a signal corresponding to the information. The assembly further comprises a panel display device that receives the signal from the media player and displays a visual representation of the signal. The assembly further comprises a housing assembly that houses the media player and the panel display device as a substantially single unit. The housing assembly facilitates mounting of the substantially single unit to the head restraint.

Yet another aspect of the present teachings relates to a method of mounting an entertainment system to a head restraint of a vehicle. The method includes housing a media player and a panel display as a substantially single unit such that a signal output by the media player is received by the panel display and displayed as a visual representation. The method further includes mounting the housed substantially single unit to the head restraint.

Yet another aspect of the present teachings relates to a head restraint for a vehicle, where the head restraint includes a support member that provides structural integrity of the head restraint. The head restraint further includes an electronic entertainment component disposed at least partially within the rear portion of the head restraint. The head restraint further includes a coupling member that mechanically couples the electronic entertainment component to the support member. The coupling member dissipates at least a portion of energy associated with an impact of an object on the electronic entertainment component.

4

These and other features and advantages of the present teachings will become more fully apparent from the following description taken in conjunction with the accompanying drawings.

BRIEF DESCRIPTION OF THE DRAWINGS

FIG. 1A illustrates an adjustable head restraint for a vehicle seat having an integrated video screen mounted therein.

FIG. 1B illustrates a fixed head restraint for a vehicle seat having the integrated video screen of FIG. 1A mounted therein.

FIG. 2 illustrates a side view of the adjustable head restraint shown in FIG. 1A having the integrated video screen mounted therein with a recessed orientation.

FIGS. 3A, 3B illustrate a cross-sectional view of the adjustable head restraint shown in FIG. 1A having the integrated video screen mounted therein with a screen cover.

FIG. 4 illustrates a cross-sectional view of the integrated video screen being mounted to the head restraint via a carrier receptacle, a carrier member, and a plurality of fasteners.

FIG. 5 illustrates a perspective view of the integrated video screen being mounted to the head restraint via the carrier member and the plurality of fasteners of FIG. 4.

FIGS. 6A, 6B illustrate a perspective view of mounting the integrated video screen to the carrier member.

FIG. 6C illustrates a side view of mounting the integrated video screen to the carrier member via pivot member.

FIG. 7 illustrates a perspective view of mounting the integrated video screen to the adjustable head restraint of FIG. 1A.

FIG. 8 illustrates a cross-sectional view of the video screen mounted to the head restraint, wherein an outer skin from the head restraint is secured to the carrier receptacle.

FIG. 9A illustrates one embodiment of a video system for a vehicle seat having a head restraint with an integrated video monitor and a side-loading media player.

FIG. 9B illustrates another embodiment of the video system for a vehicle seat.

FIG. 9C illustrates a plurality of recesses formed in the head restraint.

FIG. 10 illustrates another embodiment of a video system for the vehicle seat having the head restraint with the integrated video monitor and a top-loading media player.

FIGS. 11A-11C illustrate still another embodiment of a video system for the vehicle seat having the head restraint with a pivotally attached video monitor and media player.

FIGS. 12A-12B illustrate side views of the video system of FIGS. 11A-11B.

FIG. 13 illustrates an exploded view of the video system.

FIGS. 14A and B illustrate cutaway views of energy dissipating head restraint assemblies for adjustable and fixed vehicle seats having a media component.

FIGS. 15A and B illustrate dissipation of energy due to an impact force on the media component.

FIGS. 16A and B illustrate one embodiment of an energy dissipating coupling between the media component and a support member associated with the vehicle seat, where energy is dissipated by deformation of one or more deformable tabs associated with the coupling.

FIGS. 17A-D illustrate one embodiment of the energy dissipating coupling of FIGS. 16A and B.

DETAILED DESCRIPTION OF THE PREFERRED EMBODIMENT

Reference will now be made to the drawings wherein like numerals refer to like parts throughout. A head restraint for

vehicle seats having an integrated video screen mounted therein in a flush or recessed manner will be described in greater detail herein below with reference to the drawings. In one aspect, it should be appreciated that the term vehicle seats refers to a plurality of generally known vehicle seats, such as those manufactured for automobiles, buses, boats, cars, semi-trucks, etc., wherein the following discussion can be similarly applied to these various types of vehicle seats without departing from scope of the present teachings. In addition, the following discussion refers to mounting the integrated video screen to the head restraint of vehicle seats but may also be applied to other various component features of vehicle seats, such as the seat back, without departing from the scope of the present teachings.

FIG. 1A illustrates an adjustable head restraint 100 for a first vehicle seat 102 having an integrated video screen 104 mounted therein. As illustrated in FIG. 1A, the adjustable head restraint 100 is coupled to the seat 102 via posts 107 that extend therefrom and allow vertical adjustment of the adjustable head restraint 100 with respect to the seat 102 in a generally known manner. FIG. 1B illustrates a fixed head restraint 110 for a second vehicle seat 112 having the integrated video screen 104 mounted therein. In one embodiment, the video screen 104 is mounted within a head restraint bun 106, 116 (FIG. 1A) that is adapted to receive the video screen 104 for firm attachment therein in a manner that will be described in greater detail herein below. In addition, as will be described in greater detail herein below, the video screen 104 is mounted such that a front surface 120 of the video screen 104 is either flush or recessed from a contour 122 (FIG. 1A) of the head restraint 100 (FIG. 1A), 110.

As shown in FIGS. 1A and B, the video screen 104 comprises a panel type display. In one embodiment, the video screen 104 comprises a generally known LCD (liquid crystal display). Other panel type devices, such as flat panel or flexible panel display devices can also be used as the video screen 104. Such a monitor or terminal that can be electrically coupled to a video entertainment system so as to receive video signals therefrom for viewing of movies, television, internet web pages, video games, etc. As illustrated, the video screen 104 is generally rectangular in shape with the planar front surface 120 that is viewable by a user. In one aspect, it should be appreciated that the degree of recessed depth (with no depth comprising a flush mount) of the integrated video screen 104 and the manner in which the contour 122 of the seat 102, 112 is shaped may be selected such that the shape (side view, for example) of the head restraint 100, 110 with the integrated video screen 104 mounted therein is generally similar to the shape of the head restraint 100, 110 without the integrated video screen 104. Moreover, it should be appreciated that the vehicle seats 102, 112 may comprise any one of a number of various types or models of generally known vehicle seats without departing from the scope of the present invention.

FIG. 2 illustrates a side view of the adjustable head restraint 100 shown in FIG. 1A having the integrated video screen 104 mounted therein with a recessed orientation. It should be appreciated that the following discussion is with respect to the adjustable head restraint 100 of FIG. 1A but may be similarly applied to the fixed head restraint 110 of FIG. 1B without departing from the scope of the present teachings.

FIG. 2 further illustrates the side view shape or contour 122 of the head restraint 100. As illustrated in FIG. 2, the contour 122 of the head restraint 100 is maintained due to the recessed orientation of the video screen 104 within the head restraint bun 106. In addition, an opening 130 is formed in a rear section 132 of the head restraint 100 so as to define a substan-

tially rectangular interior region 136 within the head restraint bun 106 below an outer surface 134 of the head restraint 100. As further illustrated in FIG. 2, the video screen 104 can then be positioned adjacent the opening 130 so as to be firmly positioned within the interior region 136 of the head restraint bun 106. Moreover, the recessed orientation may be defined by a depth 138 between the front surface 120 of the video screen 104 and the outer surface 134 of the head restraint 100. The depth 138 therebetween may vary in magnitude depending on the thickness of the head restraint bun 106 and/or the internal structural characteristics of the head restraint 100, which may vary with respect to the type or model of vehicle seat used. In one embodiment, the depth 138 of the recessed orientation may comprise a magnitude of approximately zero so as to define a flush mounted video screen 104, wherein the front surface 120 of the video screen 104 is generally aligned with the outer surface 134 of the head restraint 100.

In one embodiment, orientation of the video screen 104 can be adjusted to provide an generally optimal viewing angle for an occupant. Such an orientation of the video screen 104 in some embodiments of the head restraint 100 may result in the front surface 120 being not generally parallel to the outer surface 134 of the head restraint 100. In such an embodiment, the video screen 104 is mounted in the head restraint 100 so as to generally maintain the cosmetic integrity of the original design while providing a generally optimal viewing angle.

FIG. 3A illustrates a cross-sectional view of the adjustable head restraint 102 shown in FIG. 1A having the integrated video screen 104 mounted therein with the recessed orientation shown in FIG. 2 and a screen cover 140. In one embodiment, the screen cover 140 is coupled to the rear section 132 of the head restraint 100 via a hinge 142 so as to overlie the video screen 104 and at least part of the opening 130 formed therein. The screen cover 140 may comprise generally rectangular shape and is oriented generally parallel to the front surface 120 of the video screen 104 so as to temporarily occlude the video screen 104. In one aspect, as further illustrated in FIG. 3A, the screen cover 140 can be positioned adjacent the opening 130 so as to substantially align with the outer surface 134 of the head restraint 100 thus forming a flush mounting therewith. It should be appreciated that the screen cover 140 may be positioned within the opening 130 so as to be recessed with respect to the outer surface 134 of the head restraint 100 without departing from the scope of the present teachings. Moreover, the screen cover 140 may comprise a rigid material, such as plastic, metal, etc. Alternatively, in another aspect, the screen cover 140 may comprise a piece or flap of material from an outer skin 230 (FIG. 8) of the vehicle seat 102 that is attached to the head restraint 100 adjacent the lower side of the video screen 104.

In still another aspect, as illustrated in FIG. 3B, the screen cover 140 may comprise an impact attenuating section 143 comprising a material such as foam, various types of padding, an air cushion, etc. so as to soften the force of an impact from an object. For example, during a car accident, a person's head may be propelled towards the screen cover 140, wherein the impact attenuating material may soften the impact to the head restraint 102 to thereby protect the person's head and the video screen 104 from damage.

Also, in one embodiment, the video screen 104 can be viewed by opening the screen cover 140 or temporarily occluded by closing the screen cover 140. Hence, the screen cover 140 can be outwardly rotated about the hinge 142 in a first direction 144 to openly view the video screen 104, or the screen cover 140 can be inwardly rotated about the hinge 142 in a second direction 146 opposite the first direction 144 to temporarily occlude the video screen 104. Advantageously,

US 7,597,393 B1

7

the screen cover 104, when closed, conceals the video screen 104 from view thus, in some situations, functions as a thief deterrent.

Moreover, in one aspect, the recessed configuration of the video screen 104 facilitates the manner in which the screen cover 140 may be deployed. For example, the video screen 104 may not physically interfere with the closing of the screen cover 140. In addition, as illustrated in FIGS. 3A, 3B, the screen cover 140 is intended to "hide" the video screen 104 from outside observers, thereby reducing the probability that the video screen 104 will be a target of theft. As further illustrated in FIGS. 3A, 3B, the screen cover 140 may further comprise a means for engagement 147 that allows the screen cover 140 to remain in the "up" or closed configuration. In general, it should be appreciated that some possible means for achieving such an engagement include but are not limited to magnetic strips, mechanical clips, velcro strips, and the like.

FIG. 4 illustrates a cross-sectional view of the integrated video screen 104 being mounted to the head restraint 100 via a carrier receptacle 150, a carrier member 160, and first fasteners 170. FIG. 5 illustrates a perspective view of the integrated video screen 104 being mounted to the head restraint 100 via the carrier receptacle 150, the carrier member 152, and the first fasteners 170. In one embodiment, the carrier receptacle 150 comprises a plurality of planar sidewalls 152 and a rear planar wall 154 that are joined together in a manner so as to form a substantially rectangular outer structure 156 having an inner recessed region 158 that is adapted to receive the carrier member 160 therein. Similarly, the carrier member 160 comprises a plurality of planar sidewalls 162 and a rear planar wall 164 that are joined together in a manner so as to form a substantially rectangular outer structure 166 having an inner recessed region 168 that is adapted to receive the video screen 104 therein.

As illustrated in FIG. 4, the video screen 104 may be mounted within the carrier member 160 via side fasteners 180 (shown in FIGS. 6A, 6B) and then the carrier member 160 is mounted within the carrier receptacle 150 via the first fasteners 170 so as to simplify the mounting of the video screen 104 to the head restraint 100 including the head restraint bun 106. In one aspect, the first fasteners 170 may comprise a plurality of flexible engagement members 172 that extend therefrom so as to mechanically couple with a plurality of mounting apertures 174 (FIG. 5) formed in the rear wall 154 of the carrier receptacle 150. The first fasteners 170 may further comprise a central member 173 that extends outward from the rear wall 164 of the carrier member 160. Also, the flexible engagement members 172 are attached to the central member 173, wherein the flexible engagement members 172 are deformable so as to allow insertion of the central member 173 into the mounting apertures 174 in the rear wall 164 of the receptacle member 150. Moreover as shown in FIG. 4, the flexible engagement members 172 are biased outward so as to inhibit removal of the central member 173 from the mounting apertures 174 in the rear wall 154 of the receptacle member 150. In addition, the first fasteners 170 comprise a head 176 that abuts the rear wall 164 of the carrier member 152 and is positioned through a plurality of second apertures 178 formed in the rear wall 164 of the carrier member 160.

Advantageously, as shown in FIGS. 4 and 5, the video screen 104 can be mounted to the head restraint 100 via the carrier receptacle 150 and the carrier member 160 without using external fasteners that may be seen. Hence, the video screen 104 can be mounted to the head restraint 100 in a more aesthetically appealing manner, wherein the front surface 120 of the video screen 104 recessed or flush mounted with

8

respect to the outer surface 134 of the head restraint 100, and wherein the first and second fasteners 170, 180 are concealed from view.

As illustrated in FIG. 5, the sidewalls 152 of the carrier receptacle 150 each comprise at least one sidewall aperture 200 having at least one serrated tooth 202 protruding from an interior sidewall 204. In one embodiment, the at least one serrated tooth 202 is triangular in shape having a pointed tip 206 that projects outward from the interior sidewall 204 in a horizontal manner. It should be appreciated that the serrated tooth 202 may comprise any one of a number of various shapes known in the art without departing from the scope of the present teachings. Additionally, as will be also shown in FIG. 8, the pointed tip 206 engages with the outer skin 230 (FIG. 8) and inhibits removal of the outer skin 230 from the at least one sidewall aperture 200 formed in the carrier receptacle 150. Advantageously, as will be described in greater detail herein below, the serrated tooth 202 allows outer skin from the buns 106, 116 (FIGS. 1A and B) to be attached to the carrier receptacle 150 by wrapping the outer skin around the planar sidewalls 152 and into the recessed region 158 of the carrier receptacle 150 and then securing the outer skin to the serrated tooth 202.

FIG. 6A illustrates a perspective view of attaching the integrated video screen 104 to the carrier member 160 via the second fasteners 180. In one embodiment, the planar sidewalls 162 of the carrier member 160 comprise pivot apertures 184 that allow the video display 104 to be mounted to the carrier member 160. Also, the pivot apertures 184 are adapted to rotatably receive the second fasteners 180. As illustrated in FIG. 6A, one embodiment of the second fasteners 180 comprise a threaded region 186 that mechanically couples to threaded apertures 196 (FIG. 7) formed in the video screen 104 in a generally known manner so as to be securely attached thereto. Moreover, the second fasteners 180 further comprise a head 182 and a smooth pivot region 188 interposed between the threaded region and the head 182.

In one aspect, the pivot region 188 of the second fastener 180 rotatably communicates with the pivot aperture 184 of the carrier member 160 to thereby allow the video screen 104 to pivot or tilt with respect to the carrier member 160 and/or the head restraint 100, 110 along a horizontal pivot axis 190 defined by the horizontally mounted second fasteners 180. Hence, the video screen 104 is pivotally attached to the carrier member 160 such that the plane of the video screen 104 can be adjusted with respect to the head restraint 100, 110 by a user about the defined horizontal pivot axis 190. Advantageously, the horizontal pivot axis 190 allows the video screen 104 to readily pivot when mounted to the head restraint 100, 110 to thereby allow greater positional flexibility during viewing of the video screen 104 by a user.

FIG. 6B further illustrates a perspective view of attaching the integrated video screen 104 to the carrier member 162 via the second fasteners 180. In one embodiment, as illustrated in FIG. 6B, the second fasteners 180 can be mounted vertically through the planar sidewalls 162 of the carrier member 160. The pivot region 188 of the vertically mounted second fasteners 180 rotatably communicates with the pivot aperture 184 of the carrier member 160 to thereby allow the video screen 104 to pivot or tilt side-to-side with respect to the carrier member 160 and/or the head restraint 100, 110 along a vertical pivot axis 191 defined by the vertically mounted second fasteners 180. Hence, the video screen 104 is pivotally attached to the carrier member 160 such that the plane of the video screen 104 can be adjusted with respect to the head restraint 100, 110 by a user about the vertical pivot axis 191. Advantageously, the vertical pivot axis 191 allows the video

US 7,597,393 B1

9

screen 104 to readily pivot when mounted to the head restraint 100, 110 to thereby allow greater positional flexibility during viewing of the video screen 104 by a user.

In one aspect, it should be appreciated that the second fasteners 180 may comprise generally known screws, such as sheet metal screws, without departing from the scope of the present invention. It should also be appreciated that the pivot region 188 of the second fasteners 180 may be threaded in a manner such that the video screen 104 can still pivot with respect to the carrier member 150 without departing from the scope of the present invention.

FIG. 6C illustrates a view of attaching the integrated video screen 104 to the carrier member 160 via a pivot member 240. In one embodiment, as illustrated in FIG. 6C, the pivot member 240 comprises a spherical ball 242 attached to the video screen 104 via a shaft 244 and a plate 246. The spherical ball 242 is positioned within a spherical receptacle 248 formed in the rear wall 164 of the carrier member 160. As illustrated in FIG. 6C, the rear wall 164 of the carrier member 160 may be dimensioned so as to accommodate the spherical receptacle 248. In one aspect, the plate 246 of the pivot member 240 may be attached to the video screen 104 using an adhesive, such as epoxy or glue, or fasteners, such as screws or bolts. In addition, the shaft 244 distally extends from the plate 246 towards the spherical receptacle 248 of the carrier member 160. Also, the shaft 244 and the spherical ball 242 may be formed as an integral part of the plate 246 or may be formed separately and interconnected to the plate 246 via an adhesive or fasteners.

Moreover, once the pivot member 240 is attached to the video screen 104 in a manner as previously described, the spherical ball 242 of the pivot member 240 can be pressed to fit within the spherical receptacle 248 formed in the rear wall 164 of the carrier member 160. In one aspect, the spherical ball 242 may be sized at least less than the size of the spherical receptacle 248 so as to allow rotational movement therein. Advantageously, the resulting interconnection between the spherical ball 242 of the pivot member 240 and the spherical receptacle 248 of the carrier member 160 defines a pivot point 250 to thereby allow the Video screen 104 to pivot, tilt, or rotate in a multi-directional manner with respect to the defined pivot point 250. Therefore, the defined pivot point 250 allows the video screen 104 to readily pivot when mounted to the head restraint 100, 110 to thereby allow greater positional flexibility during viewing of the video screen 104 by a user.

FIG. 7 illustrates a perspective view of mounting the integrated video screen 104 to the head restraint 100, 110 of FIGS. 1A and B. In one embodiment, as illustrated in FIG. 7, the opening 130 is formed in the head restraint bun 106 so as to define the substantially rectangular interior region 136 and to receive the carrier receptacle 150. The carrier receptacle 150 can then be positioned within the opening 130 so that the planar sidewalls 152 and the planar rear wall 154 abut the interior walls 226 of the mounting recess 136 formed in the head restraint bun 106. In one embodiment, the carrier receptacle 150 can be secured to the head restraint 100, 110 via one or more third fasteners 220, such as screws, machine screws, sheet metal screws, clips, etc. As illustrated in FIG. 7, the third fasteners 220 are positioned through rear wall apertures 222 formed in the rear wall 154 of the carrier receptacle 150 and coupled to rear mounting apertures 224 formed in a back wall 228 of the mounting recess 136 of the head restraint bun 106. Advantageously, the third fasteners 220 can be securely attached to a structural component (not shown) of the head restraint 100, 110, such as an internal framework member of

10

the head restraint 100, 110, so as to form a rigid attachment between the carrier receptacle 150 and the head restraint 100, 110.

In addition, the video screen 104 may be mounted to the carrier member 160 so as to pivot with respect thereto in a manner as previously described with reference to FIGS. 6A, 6B, 6C. Following, the carrier member 160 including the video screen 104 can then be mounted to the carrier receptacle 150 via the first fasteners 170 in a manner as previously described with reference to FIG. 4. Advantageously, this method of attaching the video screen 104 to the head restraint 100, 110 via the carrier receptacle 150, the carrier member 160, and the fasteners 170, 180 allows the video screen 104 to be securely mounted to the head restraint 100, 110 while providing a means for pivoting the video screen 104 with respect to the head restraint 100, 110 so as to improve the viewing range by a user. It will be appreciated that the mounting assembly describe above in reference to FIG. 7 may also be used in the head restraint 110 of the bucket type seat of FIG. 1B.

FIG. 8 illustrates a cross-sectional view of the video screen 104 mounted to the head restraint 100, wherein the outer skin 230 of the head restraint 100 of the vehicle seat 102 is attached to the carrier receptacle 150 and the carrier member 160 with the video screen 104 mounted therein is mounted within the mounting recess 136 of the carrier receptacle 150. As is generally known, many vehicle seats comprise the illustrated outer skin 230, such as fabric, leather, upholstery, vinyl, etc., that provides a outer surface 232 for a user to lean against or rest upon. In one aspect, when mounting the integrated video screen 104 into the head restraint 100, 112 of the vehicle seat 102, 112, the outer skin 230 is adapted to accommodate the video screen 104 including the carrier receptacle 150. In some situations, one or more flaps 234 can be formed in the outer skin 230 and attached to the one or more serrated teeth 202 formed in the planar sidewalls 152 of the carrier receptacle 150.

As further illustrated in FIG. 8, the carrier receptacle 150 may be positioned within the mounting recess 136 formed in the head restraint bun 106, and then the outer skin 230 is secured to the serrated teeth 202 via the flaps 234 formed therein by hooking the flaps 234 to one or more of the serrated teeth 202. Once the outer skin 230 is attached to the serrated teeth 202 via the flaps 234, the carrier member 160 is firmly pressed within the mounting recess 136 of the head restraint bun 106 so that the first fasteners 170 couple to the mounting apertures 174 formed in the rear wall 154 of the carrier receptacle 150.

Advantageously, this interconnection between the carrier member 160 and carrier receptacle 150 provides a quick and easy means for mounting of the video screen 104 to the head restraint 100, 110. In addition, the pressed fit of the outer skin between the carrier member 160 and the carrier receptacle 150 further secures the outer skin of the vehicle seat 102, 112 to the carrier receptacle 150. As a result, the outer skin is securely held to the carrier receptacle 150 via the one or more serrated teeth 202 formed in the planar sidewalls 152 of the carrier receptacle 150 and the pressed fit of the carrier member 160 within the mounting recess 136 of the carrier receptacle 150.

FIG. 9A illustrates one embodiment of a video system 300 for a vehicle seat or seat back 302 having a head restraint 304 with an integrated video display or monitor 306 and a side-loading media player 308 mounted therein. In one embodiment, as illustrated in FIG. 9A, the head restraint 304 is coupled to the vehicle seat or seat back 302 via posts 310 that extend therefrom and allow vertical adjustment of the head

US 7,597,393 B1

11

restraint 304 with respect to the vehicle seat 302 in a generally known manner. In one aspect, the video monitor 306 is mounted within a rear section 312 of the head restraint 304 of the vehicle seat 302 that is adapted to receive the video monitor 306 for secure attachment therein.

In addition, the video monitor 306 is generally rectangular in shape with a planar front surface 320 that is viewable by a user. Also, the video monitor 306 is mounted such that the front planar surface 320 thereof is either flush or recessed from a rear contour 322 of the head restraint 304. In one embodiment, the video monitor 306 comprises a panel display device. Such a panel device may comprise, by way of example, a flat panel display, a flexible panel display, or a liquid crystal display (LCD). Such a monitor or terminal that can be electrically coupled to a video entertainment system including the illustrated media player 308 so as to receive video signals therefrom for viewing of movies, television, internet web pages, video games, etc.

In one embodiment, the media player 308 is mounted within a first side section 316 of the head restraint 304 that is adapted to receive the media player 308 for secure attachment therein. In addition, the media player 308 is generally rectangular in shape with a planar front surface 330 that is accessible by a user from the first side section 316 of the head restraint 304. Also, the media player 308 is mounted such that the front planar surface 330 thereof is either flush or recessed from a first side contour 332 of the head restraint 304. It should be appreciated that the media player 308 may also be mounted on a second side section 318 of the head restraint 304 in a similar manner without departing from the scope of the present teachings. In addition, it should also be appreciated that a recess (shown in FIG. 9C as 328) may be formed in the side section 316 of the head restraint 304 and may be adapted to receive the media player 308 for secure attachment therein without departing from the scope of the present teachings.

Additionally, in one aspect, the media player 308 may comprise a generally known digital video disc (DVD), hard disc storage, memory chip, and the like player that can be electrically coupled to a video entertainment system including the illustrated video monitor 306 so as to provide video signals thereto for displaying of movies, television, internet web pages, video games, etc. In addition, the media player 308 is mounted within the head restraint 304 so as to not interfere with the operation of the panel display 306. Moreover, in another aspect, the media player 308 is electrically coupled to the panel display 306 such that, during operation, a user can insert a media storage device, such as a DVD (not shown), into the media player 308 in a generally known manner so as to view images stored on the media storage device via the panel display 306. Furthermore, in still another aspect, the panel display 306 may further comprise an audio interface 334, such as a headphone jack, that is electrically coupled to the media player 308 so as to provide audio signals thereto for listening to movies, television, music, video games, etc. In one embodiment, the panel display 306 may include one or more interfaces, such as audio/visual jacks, for viewing signals from one or more auxiliary media devices.

In another aspect, the video system 300 may comprise a wireless component that can be used to receive wireless communication signals for communication with a backbone network (not shown). For example, the backbone network may include various wireless information exchange networks, such as an Ethernet, Intranet, and/or Internet server or communications interface. In general, the video system 300 may establish a communication link with the backbone network, which may comprise various types of external wireless com-

12

munication links via satellite or antenna, hardwired communication links within the vehicle for internal communications, or some combination thereof to facilitate the exchange of information between the video system 300 and the backbone network.

Advantageously, a user may interact with the backbone network via the video system 300 to stream video, exchange images, download audio files, text messaging, online financial transactions, remote teleconferencing, etc. In addition, the media player 308 may be adapted to comprise digital memory components, such as hard drives, flash memory, magnetic memory, various types of non-volatile memory components, etc., for storing audio, video, and data files and information for viewing, exchanging, and processing thereof at the convenience of the user for purposes of personal entertainment, business operations, etc.

Moreover, the media player 308 including the panel display 306 may comprise various types of input ports, such as USB, serial, parallel, firewire, RCA, etc., to facilitate peripheral interconnection, such as connection to PDAs, laptop computers, printers, various types of storage media, audio/video devices, speaker systems, etc., for the purpose of interaction therewith. Therefore, the video system 300 including the panel display 306 and the media player 308 can be advantageously adapted to integrate various technologies that are associated with most computer based systems.

Furthermore, it should be appreciated that the degree of recessed depth (with no depth comprising a flush mount) of the panel display 306 and the integrated media player 308 may be selected such that the shape (front or side view, for example) of the head restraint 304 with the panel display 306 and media player 308 mounted therein is generally similar to the shape of the head restraint 304 without the panel display and player positioned therein. In addition, it should also be appreciated that the vehicle seats 302 may comprise any one of a number of various types or models of generally known vehicle seats without departing from the scope of the present teachings.

FIG. 9B illustrates another embodiment of the video system 300 for a vehicle seat 362 having the head restraint 304 formed as part of the vehicle seat or seat back 302. It should be appreciated that the video system 300 including the video display and player may be integrated into the illustrated vehicle seat 362.

FIG. 9C illustrates first and second recesses 326, 328 formed in the head restraint 304. In one embodiment, the recesses 326, 328 are formed in the head restraint 304 so as to receive the panel display 306 and media player 308, respectively, for secure attachment thereto. As illustrated in FIG. 9C, the first recess 326 may be formed in the rear section 312 of the head restraint 304 and may be adapted to receive the panel display 306 for secure attachment therein. Also, as further illustrated in FIG. 9C, the second recess 328 may be formed in the first side section 316 or second side section 318 of the head restraint 304 and may be adapted to receive the media player 308 for secure attachment therein. It should be appreciated by those skilled in the art that the recesses 326, 328 may be formed in the vehicle seat 362 of FIG. 9B without departing from the scope of the present teachings.

FIG. 10 illustrates another embodiment of a video system 350 for the vehicle seat 302 having the head restraint 304 with the panel display 306 and a top-loading media player 308 mounted thereto. As illustrated in FIG. 2, the panel display 306 is mounted within the head restraint 304 in a manner as previously described. Alternatively, the media player 308 is mounted within an upper section 352 of the head restraint 304 that is adapted to receive the media player 308 for secure

attachment therein. In addition, the planar front surface 330 of the media player 308 is accessible by a user from the upper section 352 of the head restraint 304. Also, the media player 308 is mounted such that the front planar surface 320 thereof is either flush or recessed from an upper contour 354 of the head restraint 304. Moreover, the media player 308 is mounted within the upper section 352 of the head restraint 304 so as to not interfere with the operation of the panel display 306.

It should be appreciated by those skilled in the art that the panel display 306 and media player 308 function in a similar manner as previously described with reference to FIG. 9A. In addition, it should also be appreciated that a recess (not shown) may be formed in the upper section 352 of the head restraint 304 and may be adapted to receive the media player 308 for secure attachment therein without departing from the scope of the present teachings. Moreover, it should also be appreciated by those skilled in the art that the top-loading media player 308 as illustrated in FIG. 10 may be formed in the vehicle seat 362 of FIG. 9B without departing from the scope of the present teachings.

FIGS. 11A-11C illustrate still another embodiment of a video system 370 for the vehicle seat 302 having the head restraint 304 with the panel display 306 and media player 308 pivotally attached thereto. FIG. 12A illustrates a side view of the video system 370 illustrated in FIG. 11A in a deployed orientation 380. FIG. 12B illustrates a side view of the video system illustrated in FIG. 11A in a retracted orientation 382. As illustrated in FIGS. 11A-11B, the panel display 306 and media player 308 are mounted within a recess 384 formed in the rear section 312 of the head restraint 304 that is adapted to receive the panel display 306 and media player 308 for pivotal attachment therein.

In one embodiment, the panel display 306 and media player 308 are mounted within a housing 340 (FIG. 12A) so as to define the video system 370, which can be retracted and deployed from the recess 384 via a pivot member 386 (FIGS. 12A-12B). As illustrated in FIG. 1A, the planar front surface 330 of the media player 308 is accessible from a top portion 342 of the housing 340 by a user when the housing 340 or video system 370 is pivoted from the recess 384 in the deployed orientation 380 (FIG. 12A). In another embodiment, as illustrated in FIG. 1B, the media player 308 may be mounted within the housing 340 adjacent to the side portion 344 of the housing 340 so as to be accessible therefrom. In addition, it should be appreciated by those skilled in the art that the pivotally mounted video system 370 as illustrated in FIGS. 11A-12B may be mounted to the vehicle seat 362 of FIG. 9B without departing from the scope of the present teachings.

FIG. 11C illustrates the panel display 306 and media player 308 partially deployed or pivoted outward from the head restraint 304 of the vehicle seat 302. In one embodiment, the pivot member 386 (FIGS. 12A-12B) allows the panel display 306 and media player 308 to be deployed or pivoted a first distance from the recess 384 formed in the head restraint 304 so that storage media 440 (FIG. 13), such as a compact disc (CD) or digital video disc (DVD), can be received by the media player 308 for viewing thereof. It should be appreciated by those skilled in the art that the pivotal displacement of the panel display 306 and media player 308 from the recess 384 may vary in length without departing from the scope of the present teachings.

Advantageously, this allows a user to readily access the media player 308 for insertion and ejection of storage media into and out of the media player 308. In addition, the planar front surface 320 (FIG. 10) of the panel display 306 is view-

able by a user when the video system 370 is pivoted within the recess 384 in the retracted orientation 382 (FIG. 12B). As illustrated in FIG. 12B, the retracted orientation 382 of the video system 370 allows a user to readily view images displayed on the panel display 306. Moreover, the panel display 306 and media player 308 function in a similar manner as previously described with reference to FIG. 9A.

As further illustrated in FIGS. 12A-12B, the pivot member 386 pivotally attaches the video system 370 to the inner sidewalls of the recess 384 formed in the rear section 312 of the head restraint 304. Advantageously, the pivot member 386 allows for the video system 370 to be pivoted outward from the recess 384 so that a user can readily access the media player 308, and, in addition, the pivot member 386 also allows for the video system 370 to be pivoted towards the recess 384 so as to engage the recess 384 in the retracted orientation 382 so that user can readily view the panel display 306. As further illustrated in FIGS. 12A-12B, the head restraint 304 may further comprise a means for engagement 390 that allows the video system 370 to be secured in the retracted orientation 382. In general, it should be appreciated that some possible means for achieving such an engagement include but are not limited to magnetic components, mechanical clips, velcro strips, and the like.

FIG. 13 shows an exploded view of one embodiment of a media system 300 mounted to a head restraint 304. In one embodiment, the head restraint 304 is an adjustable head restraint, and includes a support member 450 mounted to generally vertical posts 310. The head restraint may also be a generally fixed part of a seat such as a bucket seat. Thus, the concepts of mounting the media system to the head restraint also apply to the fixed seats.

As shown in FIG. 13, a receptacle 404 is shown to mount to the support member 450 by a first fasteners 410. The first fasteners 410 may include screws, clips, and other fastening means. Thus in the embodiment shown in FIG. 13, the receptacle 404 is mounted substantially within the head restraint 304 so as to be able to receive the media system 300 through an opening 384 defined by the head restraint 304 in a manner described below.

In one embodiment, the receptacle 404 may be incorporated into the head restraint 304 by having a bun material (such as foam) molded about the receptacle 404. Thus, although the receptacle 404 is shown to be mounted to the support member 450 in FIG. 13, it will be understood that the receptacle 404 can be mounted to the head restraint 304 by such molding process.

As further shown in FIG. 13, one embodiment of the media system 300 includes a housing that houses a media player 308 and a panel display 306 as a substantially single unit. Such a modular media system 300 can be mounted generally within the receptacle 404 quickly and efficiently.

In one embodiment, the housing includes a shell member 424 that allows mounting of the media player 440 and the panel display 306 such that the viewable portion of the panel display 306 generally faces towards a viewer. The media player 440 can be mounted to the shell member 424 in a number of ways, and the panel display 306 can be mounted adjacent the media player 440 in a number of ways. In one embodiment, the media player 440 can be mounted to a rear plate member 422 via mounting members 430 and second fasteners 432. The second fasteners may include screws, clips, and other fastening means. The rear plate member 422 can be mounted to the shell member 424 in a number of ways, including but not limited to fasteners such as screws, clips, retainer, and the like.

In one embodiment, the media system 300 also includes a front plate member 420 that generally frames the panel display 306. In one embodiment, the front plate member 420 includes tabs 434 that are adapted to mount to other parts of the housing thereby at least partially encapsulating the media player 308 and the panel display 306 as a modular unit.

In one embodiment, the shell member 424 that houses the media player 308 and the panel display 306 is coupled to a carrier member 402. The coupling between the shell member 424 and the carrier member 402 can be achieved in a number of ways. In one embodiment, the coupling may allow the shell member 424, and thus the media player 308 and the panel display 306, to pivot about a selected location on the carrier member 402. Thus in the embodiment shown in FIG. 13, the coupling includes pivot fasteners 412 (shown on one side) that extend through holes 442 defined by the carrier member 402, and fasten to holes 444 defined by the shell member 424. Thus, the pivot fasteners 412 allow the shell member, and thus the media player 308 and the panel display 306, to pivot about an axis defined by the pivot fasteners 412. Such a pivotable motion of the shell member 424 allows the viewer to adjust the viewing angle of the panel display 306.

In other embodiments, the shell member 424 can be coupled to the carrier member 402 to allow different pivoting motion(s). As an example, such coupling may allow the panel display to be pivoted in a side-to-side manner (by having pivot fasteners extend generally vertically). In another example, the coupling may include a ball and socket type swivel that allows the panel to be pivotally rotated about the carrier member in a number of ways. Such pivoting means are described above in reference to FIGS. 6A-C.

As further shown in FIG. 13, the carrier member 402 (with the shell member 444 mounted therein) mounts within the receptacle 404. The carrier member 402 may be mounted to the receptacle 404 in a number of ways. In one embodiment, a relatively quick mounting can be achieved by using fasteners 410 that are similar to the fasteners 170 described above in reference to FIG. 4. The carrier member 402 can also be mounted to the receptacle 404 by, for example, other forms of fasteners, clips, retainers, and the like.

Thus, one can see that in one embodiment, the carrier member 402 and various parts therein can be preassembled. The receptacle 404 can also be premounted to the head restraint 304. The mounting of the carrier member 402 can then be achieved by “snapping” the carrier member 402 within the receptacle 404, thereby simplifying the installation of the media player 308 and the panel display 306.

Such a mounted media system then allows a user to pivot the shell member 424 to allow insertion or removal of the storage media 440, such as a DVD, to or from the media player. The pivotable motion of the shell member 424 also allows the viewing angle of the panel display 306 to be adjusted.

One aspect of the present teachings relates to a head restraint having a media component mounted in a manner that allows dissipation of energy imparted on the media component when it is impacted by a moving object such as a head of an occupant. As an example, a rear passenger sitting behind a media component may experience a sudden deceleration during a frontal impact collision, and the passenger’s head or other body part may impact the media component. A dissipation of such a collision energy can reduce the likelihood and/or severity of injury to that passenger.

FIGS. 14 to 17 now show an assembly having such an energy dissipating feature. As shown in a cutaway view of FIG. 14A, one embodiment of an energy dissipating head restraint assembly 500 is adapted for an adjustable head

restraint 502. The energy dissipating assembly 500 includes one or more posts 506 that allow generally vertical adjustment of the head restraint 502, and a support member 504 mechanically coupled to the one or more posts 506, so as to provide structural integrity of the head restraint 502.

As further shown in FIG. 14A, a media component 510 is mounted at least partially within the head restraint 502. The media component 510 may be a panel display, a media player, an integrated system of media player and panel display, or any other devices disclosed herein. The media component 510 is shown to be mounted to the support member 504 by an energy dissipating coupling assembly 512 that is described below in greater detail.

FIG. 14B shows a cutaway view of one embodiment of a similar energy dissipating head restraint assembly 520 for a head restraint portion 522 of a fixed bucket-type seat. The energy dissipating assembly 520 includes a support member 524 that facilitates structural integrity of the head restraint 522. Although not shown, the support member 524 may be mechanically coupled to an internal seat frame.

As further shown in FIG. 14B, a media component 530 is mounted at least partially within the head restraint 522. The media component 530 is shown to be mounted to the support member 524 by an energy dissipating coupling assembly 532 that is described below in greater detail.

FIGS. 15A and B now show an example of how one embodiment of an energy dissipating coupling assembly 540 can work during an impact situation. For the purpose of description, a media component 542 is shown to be coupled to a support member 544 by the coupling assembly 540. It will be understood that the manner in which the coupling assembly 540 couples the media component 542 to the support member 544, and the manner in which such a coupling operates, are applicable to the adjustable or fixed head restraints, or any combinations or variations thereof.

FIG. 15A shows how the energy dissipating coupling 540 can couple the media component 542 to the support member 544. In one embodiment, the coupling 540 includes a panel 546 that is coupled to one or more energy dissipating members 550. The panel 546 is adapted to allow mounting of the media component 542 thereto. The energy dissipating member 550 can be adapted to facilitate mounting of the coupling 540 to the support member 544 or a structure associated with the support member 544, thereby providing the energy dissipation means between the media component 542 and the support member 544. It will be understood that the media component 542 may include various forms and types of devices, and various means of mounting such devices may be used.

The media component 542 can be mounted to the panel 546 in any number of ways, including but not limited to, screws, clips, retainers, adhesive, and the like. Also, the energy dissipating members 550 can be coupled to the support member 544 in any number of ways, including but not limited to, screws, clips, retainers, adhesive, and the like.

FIG. 15A shows the energy dissipating coupling 540 in a “non-deformed” configuration—that is, before being subjected to a significant impact. For the purpose of description, energy dissipation can be achieved by deformation of one or more energy dissipating couplings 540. It will be understood that the energy dissipation by deformation can be implemented in any number of ways. It will also be understood that energy can be dissipated in other modes where the deformed part(s) can be at least partially restored, such as in a damped spring type device.

FIG. 15B shows an object, such as a head 552 of an occupant, impacting a portion of the media component 542.

US 7,597,393 B1

17

thereby imparting a force 554 having a component directed generally towards the support member 544. Energy associated with such a force is shown to be dissipated by a deformation of one or more energy dissipating members 550. Such a deformation of the energy dissipating members 550 can reduce the likelihood and/or the severity of injury by the occupant caused to the impacting head 552.

FIGS. 16A and B now show top views of one embodiment of an energy dissipating coupling 560 that can be used as the coupling described above in reference to FIGS. 15A and B. The coupling 560 includes a panel 562 that can be attached to the media component 542. The coupling 560 further includes one or more tabs 566, where one end of the tab 566 is attached to the panel 562 and the other end of the tab 566 can be attached to the support member 544 or a structure associated with the support member 544. The tab 566 defines a bend 564 that can deform when subjected to a force generally between the two ends of the tab 566.

FIG. 16B shows an impact situation (where the head 552 impacts the media component 542) that causes such a deforming force (554 in FIGS. 15B and 16B). The bends 564 of the tabs 566 are shown to be deformed by at least a portion of the energy associated with the impact force 554.

FIGS. 17A-D now show an example energy dissipating coupling 570 having a plurality of deformable tabs 574. The coupling 570 includes a panel 572 that defines a plurality of mounting holes 576 that facilitate mounting of a media component (not shown). The panel 572 may include a lip 580 along an edge for improved rigidity of the panel 572.

In one embodiment, the plurality of tabs 574 are formed as extensions from the panel 572, such that a distal end 582 of each tab 574 defines a mounting hole 578 that facilitates mounting of the coupling 570 to a support member (not shown). Each tab 574 defines a deformable bend 584 between the distal end 582 and the panel 572 so as to allow energy dissipation by deformation. In one embodiment, the bend 584 defines an aperture 586, where the size of the aperture 586 can be adjusted to adjust the manner in which the bend 584 deforms.

The deformation of the bend 584 depends on factors that include magnitude of the impact force, and the mechanical property of the bend 584. In one embodiment, the coupling 570 is formed from a single piece of an 18-gauge steel. For a given gauge of material (such as the 18 gauge steel), the deformation property of the bend 584 can be adjusted by adjusting the size of the aperture 586 on the bend 584.

Although the foregoing description has shown, described and pointed out the fundamental novel features of the invention, it will be understood that various omissions, substitutions, and changes in the form of the detail of the apparatus as illustrated, as well as the uses thereof, may be made by those skilled in the art, without departing from the spirit or scope of the present invention. Consequently, the scope of the invention should not be limited to the foregoing discussion, but should be defined by the appended claims.

What is claimed is:

1. A media assembly adapted to be installed into a seat back of a vehicle, the assembly comprising:

- a mounting structure that is coupled to the seat back of the vehicle wherein the seat back defines a first outer surface visible to a viewer sitting in a back seat of the vehicle;
- a display that displays media to a viewer sitting within the vehicle;
- a media player having an input opening into which a user can position a media storage device wherein the media

18

player provides signals to the display to thereby induce the display to visually display the contents of the media storage device;

a housing defining a recess having a first opening that receives both the display and the media player such that the display is positioned proximate the first opening of the recess with the media player positioned inward in the recess from the first opening such that the media player does not impede visual access to the display wherein the housing is structured to permit selective access to the input opening of the media player to permit user positioning of the media storage device within the player and wherein the housing is adapted to be coupled to the mounting structure within the seat back of the vehicle to thereby retain the housing within the seat back such that the display is positioned adjacent the outer surface of the seat back;

wherein the housing defines a second opening and the media player is positioned within the recess such that the input opening of the media player is accessible through the second opening of the housing.

2. The assembly of claim 1, wherein the housing is pivotally mounted with respect to the mounting structure such that the display screen can be adjusted for improved visibility to the viewer.

3. The assembly of claim 2, wherein the housing comprises a ball and the mounting structure comprises a socket such that the ball is positioned within the socket to permit adjustment of the housing with respect to the mounting structure in two separate directions.

4. A media assembly adapted to be installed into a seat back of a vehicle the assembly comprising:

- a mounting structure that is coupled to the seat back of the vehicle wherein the seat back defines a first outer surface visible to a viewer sitting in a back seat of the vehicle;
- a display that displays media to a viewer sitting within the vehicle;
- a media player having an input opening into which a user can position a media storage device wherein the media player provides signals to the display to thereby induce the display to visually display the contents of the media storage device;

a housing defining a recess having a first opening that receives both the display and the media player such that the display is positioned proximate the first opening of the recess with the media player positioned inward in the recess from the first opening such that the media player does not impede visual access to the display wherein the housing is structured to permit selective access to the input opening of the media player to permit user positioning of the media storage device within the player and wherein the housing is adapted to be coupled to the mounting structure within the seat back of the vehicle to thereby retain the housing within the seat back such that the display is positioned adjacent the outer surface of the seat back;

wherein the housing is pivotally attached to the mounting structure so as to be rotatable between a recessed position wherein the display is positioned substantially flush with the first outer surface of the seat and the input opening of the media player is hidden from view within the seat and an extended position wherein the input opening of the media player is exposed from the seat so as to be accessible to the viewer.

5. The assembly of claim 4, wherein the mounting structure comprises a retainer that defines a recess having two opposed side walls positioned within the seat and wherein the housing

US 7,597,393 B1

19

is pivotally attached to the retainer at the two opposed side walls to facilitate movement between the recessed position and the extended position.

6. The assembly of claim 5, wherein the retainer defines two opposed side walls and an opposed upper and lower wall and wherein the housing is pivotally attached to the two opposed side walls adjacent the lower wall of the retainer such that the input opening of the media player is positioned proximate the upper wall of the retainer when the housing is in the recessed position.

7. An electronic assembly mounted to a head restraint of a vehicle seat, comprising:

a media player that retrieves information stored on a media storage device, processes the information, and outputs a signal corresponding to the information;

a panel display device that receives the signal from the media player and displays a visual representation of the signal, wherein the signal includes an audio component;

a housing assembly that houses the media player and the panel display device as a substantially single unit, wherein the housing assembly facilitates mounting of the substantially single unit to the head restraint;

a shell member that allows mounting of the media player and the panel display thereto; and

a carrier member dimensioned to receive the shell member therein such that the carrier member can be preassembled with the shell member having the media player and the panel display mounted thereto;

20

wherein the shell member is pivotally mounted to the carrier member so as to allow the shell member to pivot with respect to the carrier member; and

wherein the pivoting of the shell member allows pivoting of the media player for insertion or removal of a media storage device to or from the media player.

8. The assembly of claim 7, wherein the media player comprises a digital video disc player that plays a digital video disc.

9. The assembly of claim 7, wherein the media player includes a hard disc storage and plays digital information stored thereon.

10. The assembly of claim 7, wherein the media player reads and plays digital information stored on a memory chip.

11. The assembly of claim 7, wherein the panel display device comprises a flat panel display.

12. The assembly of claim 7, wherein the panel display device comprises a flexible panel display.

13. The assembly of claim 7, wherein the pivoting of the shell member allows adjust of viewing angle of the panel display.

14. The assembly of claim 7, further comprising an external interface that allows interfacing of the electronic assembly with an external electronic component.

15. The assembly of claim 14, wherein the external interface comprises a jack that allows connection with the external electronic component so as to allow the external electronic component to send an external signal to be displayed on the panel display device.

* * * * *

UNITED STATES PATENT AND TRADEMARK OFFICE
CERTIFICATE OF CORRECTION

PATENT NO. : 7,597,393 B1
APPLICATION NO. : 10/819341
DATED : October 6, 2009
INVENTOR(S) : Tuccinardi et al.

Page 1 of 1

It is certified that error appears in the above-identified patent and that said Letters Patent is hereby corrected as shown below:

Title page, item 76 (inventors), please delete "912," for Roel C. Espina and insert therefore, --902,--.

At column 9, line 40, please delete "Video" and insert therefore, --video--.

At column 13, line 38, please delete "1A," and insert therefore, --11A,--.

At column 13, line 43, please delete "1B," and insert therefore, --11B,--.

At column 18, line 34, please delete "vehicle" and insert therefore, --vehicle,--.

At column 19, line 28, please delete "therein" and insert therefore, --therein,--.

At column 20, line 20, please delete "adjust of" and insert therefore, --adjustment of a--.

Signed and Sealed this

Eighth Day of June, 2010

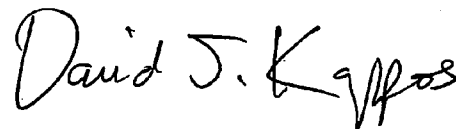

David J. Kappos
Director of the United States Patent and Trademark Office

UNITED STATES PATENT AND TRADEMARK OFFICE

CERTIFICATE OF CORRECTION

PATENT NO. : 7,597,393 B1
APPLICATION NO. : 10/819341
DATED : October 6, 2009
INVENTOR(S) : Tuccinardi et al.

Page 1 of 1

It is certified that error appears in the above-identified patent and that said Letters Patent is hereby corrected as shown below:

On the Title Page:

The first or sole Notice should read --

Subject to any disclaimer, the term of this patent is extended or adjusted under 35 U.S.C. 154(b)
by 1155 days.

Signed and Sealed this

Twenty-eighth Day of September, 2010

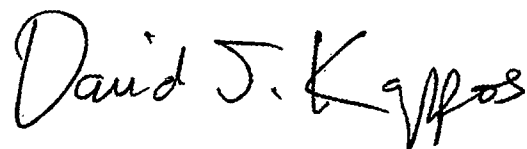

David J. Kappos

Director of the United States Patent and Trademark Office

EXHIBIT D

(FILED UNDER SEAL)

Notices

5:12-cv-02263-RGK-SP TMI Products Inc v. Rosen Entertainment Systems LP

AO120, DISCOVERY

UNITED STATES DISTRICT COURT for the CENTRAL DISTRICT OF CALIFORNIA

Notice of Electronic Filing

The following transaction was entered by Barcelo, Reynaldo on 2/13/2013 at 11:10 AM PST and filed on 2/13/2013

Case Name: TMI Products Inc v. Rosen Entertainment Systems LP

Case Number: 5:12-cv-02263-RGK-SP

Filer: TMI Products Inc

Document Number: 14

Docket Text:

NOTICE OF LODGING filed re MOTION for Leave to File First Amended Complaint and Regarding Case Management and Pleadings (*UNOPPOSED*) MOTION for Leave to File First Amended Complaint and Regarding Case Management and Pleadings (*UNOPPOSED*)[13] (Attachments: # (1) Exhibit Proposed First Amended Complaint)(Barcelo, Reynaldo)

5:12-cv-02263-RGK-SP Notice has been electronically mailed to:

Reynaldo C Barcelo rey@bhiplaw.com

5:12-cv-02263-RGK-SP Notice has been delivered by First Class U. S. Mail or by other means BY THE FILER to :

The following document(s) are associated with this transaction:

Document description:Main Document

Original filename:C:\fakepath\20130213 TMI v Rosen CACD Notice of Lodging.pdf

Electronic document Stamp:

[STAMP cacdStamp_ID=1020290914 [Date=2/13/2013] [FileNumber=15112641-0] [7db27d52353b6b2444c03d1bb91adebbc9ef150ddbe833a1bcc3395e3e644e9a21fc2f4f672308afe9597e2bce26c82ed38a2c8e4b1d9198dd45ad160d33374a]]

Document description:Exhibit Proposed First Amended Complaint

Original filename:C:\fakepath\PFAC.pdf

Electronic document Stamp:

[STAMP cacdStamp_ID=1020290914 [Date=2/13/2013] [FileNumber=15112641-1] [1b7d1b17a0f26154f2bd701ba7ddb5ea1f16c5adbbd56f1789b4a136816671c3d973320b84174d68a43adadadd2caf1b21b7c8de2d0488b26e92ec763e407b92]]