

IN THE UNITED STATES DISTRICT COURT  
FOR THE SOUTHERN DISTRICT OF NEW YORK

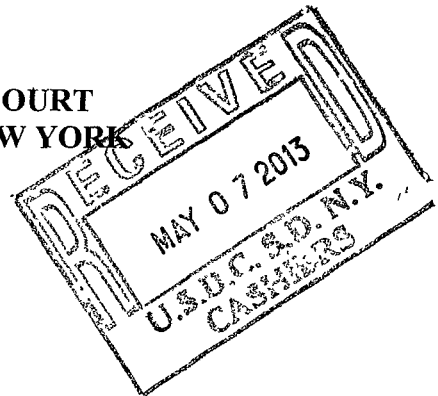

COGNEX CORP., and COGNEX  
TECHNOLOGY & INVESTMENT LLC,

Plaintiffs,

v.

MICROSCAN SYSTEMS, INC., and  
THE CODE CORPORATION,

Defendants.

Civil Action No. 13 Civ. 02027 (JSR)

**JURY TRIAL DEMANDED**

**FIRST AMENDED COMPLAINT AND JURY TRIAL DEMAND**

The plaintiffs, Cognex Corporation (“Cognex Corp.”) and its wholly-owned subsidiary Cognex Technology and Investment LLC (“CTI LLC”) (collectively, “Cognex”), by and through its attorneys, Holland & Knight LLP, bring this action for patent infringement against the defendants, Microscan Systems, Inc. (“Microscan”), and The Code Corporation (“Code Corp.”) (collectively, “Defendants”), seeking damages and injunctive relief for patent infringement.

Cognex states as follows:

**THE PARTIES**

1. Plaintiff Cognex Corp. is a corporation organized under the corporate laws of the Commonwealth of Massachusetts, with corporate headquarters and a principal place of business in Natick, Massachusetts. Plaintiff CTI LLC is a limited liability company organized under the laws of the State of California, with headquarters and a principal place of business in Mountain View, California. CTI LLC is Cognex Corp.’s wholly owned subsidiary.

2. On information and belief, defendant Microscan is a Delaware corporation with its principal place of business in Renton, Washington.

3. On information and belief, defendant Code Corp. is a Delaware corporation with its principal place of business in Bluffdale, Utah.

**JURISDICTION AND VENUE**

4. This is an action for patent infringement arising under the Patent Act, 35 U.S.C. § 1, et seq., including § 271.

5. This Court has subject matter jurisdiction over this action pursuant to 28 U.S.C. §§ 1331 and 1338.

6. This Court has personal jurisdiction over Microscan pursuant to the forum selection clause contained in a November 1, 2010 Confidential Settlement Agreement between Cognex and Microscan (“the Agreement”). In accordance with the Agreement, the United States District Court for the Southern District of New York has exclusive jurisdiction to resolve all intellectual property disputes between Cognex and Microscan and each party has consented to the jurisdiction of this Court.

7. All contractual conditions precedent to bringing this action have been performed or have occurred, in accordance with the Agreement.

8. Pursuant to the Agreement, this Court has exclusive jurisdiction over intellectual property disputes between Cognex and Microscan, and venue is proper in this District.

9. Upon information and belief, this Court has personal jurisdiction over Code Corp. in that Code Corp. has committed acts within New York and this judicial district giving rise to this action and Code Corp. has established minimum contacts with the forum such that the exercise of jurisdiction over Code Corp. would not offend traditional notions of fair play and substantial justice. For example, and on information and belief, Code Corp. actively markets and

sells its products in the state of New York, including without limitation, by acts of Code Corp.'s representatives assigned to the territory of New York and via product expositions within New York.<sup>1</sup>

10. Venue is also proper in this District pursuant to 28 U.S.C. §§ 1391 and 1400 because Defendants have committed acts of infringement here.

### COUNT I

#### (Microscan's Infringement of U.S. Patent No. 7,874,487)

11. The allegations of paragraphs 1 through 10 are incorporated by reference into this Count I as though fully set forth herein.

12. CTI LLC is the owner of all right, title, and interest in and to United States Patent Number 7,874,487 ("the '487 Patent"), entitled "Integrated Illumination Assembly For Symbology Reader." A true and accurate copy of the '487 Patent is attached hereto as Exhibit A. Cognex Corp. is the exclusive licensee to the '487 patent, with the right to sub-license. At all relevant times, Cognex Corp. has practiced its exclusive rights to the '487 patent.

13. The '487 Patent was duly and legally issued by the United States Patent and Trademark Office on January 25, 2011, and is valid and enforceable.

14. Microscan has been on notice of the '487 Patent at least as early as June 12, 2012, when Cognex sent a letter to Microscan identifying the '487 Patent and its belief that at least Microscan's Mobile Hawk™ product and/or associated software infringed one or more claims of the '487 Patent. *See* Letter from Dr. Robert Shillman to Mr. John O'Higgins, dated June 12, 2012, attached hereto as Exhibit B.

---

<sup>1</sup> *See, e.g.*, Code Corp.'s website at <http://codecorp.com/pr.php?v=59> (advertising a product launch at the 2012 National Retail Federation's Annual Convention & Expo, in New York City, New York),

15. Microscan, without authority, makes, uses, offers to sell, sells within the United States, and/or imports into the United States, products and/or software (e.g., Mobile Hawk™ product and/or associated software) that incorporate or make use of the inventions covered by the '487 Patent, thereby infringing, literally and/or under the doctrine of equivalents, contributing to the infringement of, and/or actively inducing infringement of one or more claims of the '487 Patent. Microscan's products and/or software incorporate the technology embodied in the '487 Patent.

16. Microscan has infringed and continues to infringe the '487 Patent, literally and/or under the doctrine of equivalents, either directly, by contributory infringement, or by inducing others to infringe, and will continue to do so unless enjoined by this Court.

17. Microscan has willfully infringed the '487 Patent, acting in an objectively reckless manner after having been put on notice of the '487 Patent.

18. As a direct result of Microscan's infringement, Cognex has suffered, and will continue to suffer damages, irreparable harm and impairment of the value of its patent rights.

19. Cognex has been, is being, and will continue to be, seriously damaged and irreparably harmed unless Microscan is enjoined by this Court from the actions complained of herein, and thus Cognex is without an adequate remedy at law.

20. Cognex is entitled to recover from Microscan the damages sustained by Cognex as a result of Microscan's wrongful acts in an amount subject to proof at trial.

## **COUNT II**

### **(Code Corp.'s Infringement of U.S. Patent No. 7,874,487)**

21. The allegations of paragraphs 1 through 20 are incorporated by reference into this Count II as though fully set forth herein.

22. CTI LLC is the owner of all right, title, and interest in and to the '487 Patent, entitled "Integrated Illumination Assembly For Symbology Reader." A true and accurate copy of the '487 Patent is attached hereto as Exhibit A. Cognex Corp. is the exclusive worldwide licensee to the '487 patent, with the right to sub-license. At all relevant times, Cognex Corp. has practiced its exclusive rights to the '487 patent.

23. The '487 Patent was duly and legally issued by the United States Patent and Trademark Office on January 25, 2011, and is valid and enforceable.

24. Upon information and belief, Code Corp. manufactures the Mobile Hawk™ product on behalf of Microscan. Code Corp., therefore, without authority, makes, uses, offers to sell, sells within the United States, and/or imports into the United States, products (e.g., Mobile Hawk™ product and/or associated software) that incorporate or make use of the inventions covered by the '487 Patent, thereby infringing, literally and/or under the doctrine of equivalents, contributing to the infringement of, and/or actively inducing infringement of one or more claims of the '487 Patent. Code Corp.'s products incorporate the technology embodied in the '487 Patent.

25. Code Corp. has infringed and continues to infringe the '487 Patent, literally and/or under the doctrine of equivalents, either directly, by contributory infringement, or by inducing others to infringe, and will continue to do so unless enjoined by this Court.

26. As a direct result of Code Corp.'s infringement, Cognex has suffered, and will continue to suffer damages, irreparable harm and impairment of the value of its patent rights.

27. Cognex has been, is being, and will continue to be, seriously damaged and irreparably harmed unless Code Corp. is enjoined by this Court from the actions complained of herein, and thus Cognex is without an adequate remedy at law.

28. Cognex is entitled to recover from Code Corp. the damages sustained by Cognex as a result of Code Corp.'s wrongful acts in an amount subject to proof at trial.

**PRAYER FOR RELIEF**

WHEREFORE, Cognex prays for judgment against Defendants as follows:

- (a) Declaring that Defendants have infringed the '487 Patent;
- (b) Ordering that Defendants, including their officers, agents, servants, employees, subsidiaries, attorneys, and all other persons in active concert or participation with Defendants, be preliminarily and permanently enjoined and restrained from further infringing the '487 Patent;
- (c) Awarding Cognex all relief available under the patent laws of the United States, including but not limited to monetary damages and including prejudgment interest;
- (d) Awarding Cognex enhanced damages based on Microscan's willful infringement of the '487 Patent;
- (e) Finding this to be an exceptional case, and awarding Cognex its costs and reasonable attorneys' fees in respect thereto in accordance with 35 U.S.C. §§ 284 and 285; and
- (f) Granting Cognex such other relief as the Court deems just and proper.

**JURY DEMAND**

Cognex demands a trial by jury on all issues so triable.

Dated: May 7, 2013

Respectfully Submitted,

COGNEX CORPORATION and COGNEX  
TECHNOLOGY AND INVESTMENT LLC

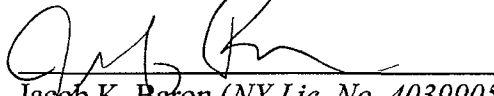

Jacob K. Baron (*NY Lic. No. 4039905*)

J. Mitchell Herbert, Jr.

*(pro hac vice admission pending)*

HOLLAND & KNIGHT LLP

10 St. James Ave., 11<sup>th</sup> Floor

Boston, MA 02116

Tel: (617) 523-2700

Fax: (617) 523-6850

[jacob.baron@hklaw.com](mailto:jacob.baron@hklaw.com)

[mitchell.herbert@hklaw.com](mailto:mitchell.herbert@hklaw.com)

*Attorneys for Plaintiffs Cognex Corporation and  
Cognex Technology and Investment LLC*

# EXHIBIT A

U.S. Patent No. 7,874,487





US007874487B2

(12) **United States Patent**  
Nunnink et al.

(10) **Patent No.:** US 7,874,487 B2  
(45) **Date of Patent:** Jan. 25, 2011

(54) **INTEGRATED ILLUMINATION ASSEMBLY FOR SYMBOLOGY READER**

(75) Inventors: **Laurens Nunnink**, Simepveld (NL);  
**William II Equitz**, Waban, MA (US)  
(73) Assignee: **Cognex Technology and Investment Corporation**, Mt. View, CA (US)  
(\* ) Notice: Subject to any disclaimer, the term of this patent is extended or adjusted under 35 U.S.C. 154(b) by 1010 days.

(21) Appl. No.: **11/257,411**  
(22) Filed: **Oct. 24, 2005**

(65) **Prior Publication Data**  
US 2007/0090193 A1 Apr. 26, 2007

(51) **Int. Cl.**  
**G06K 7/10** (2006.01)  
(52) **U.S. Cl.** ..... **235/473; 235/455; 235/462.06**  
(58) **Field of Classification Search** ..... **235/454, 235/455, 462.01, 462.22, 462.42, 473**  
See application file for complete search history.

(56) **References Cited**

**U.S. PATENT DOCUMENTS**

2,357,378 A	9/1944	Benford
3,726,998 A	-4/1973	Szpak et al.
3,857,626 A	12/1974	Rosenberger et al
3,961,198 A	6/1976	Angst et al
4,282,425 A	8/1981	Chadima et al.
4,570,057 A	2/1986	Chadima et al.
4,743,773 A	5/1988	Katana et al

(Continued)

**FOREIGN PATENT DOCUMENTS**

CN	1426570 A	6/2003
----	-----------	--------

(Continued)

**OTHER PUBLICATIONS**

The International Search Report and Written Opinion of the International Searching Authority, International Application No PCT/US2006/041041 dated May 25, 2007.

(Continued)

*Primary Examiner*—Daniel A Hess  
(74) *Attorney, Agent, or Firm*—Michael A. Jaskolski

(57) **ABSTRACT**

This provides a plurality of novel features that can be applied variously to a reader. In one embodiment, the light pipe is constructed from durable polycarbonate for increased shock resistance and can define a rectangular cross section. The chamfered end of the light pipe is textured or frosted to further diffuse refracted light passing through the end so as to present a more even effect. The conical/tapered diffuser within the light pipe is illuminated by a reflector with a white textured surface that reflects a plurality of rearward-directed illumination sources back into the diffuser. The reflector can define a predetermined cross section that directs further light into the forwardmost, remote regions of the diffuser to generate a better spread of light and alleviate spotting effects. The textured surface on the chamfered light pipe end can be employed to better project indicator light. The illumination sources are arranged in a ring at the inner end of the pipe, and can be multi-colored sources that respond to the controller to project and appropriate color and/or blink in an appropriate pattern to indicate various conditions, such as read success or failure. The controller is adapted to provide indications between image acquisitions. The controller can operate individual portions of the ring so that only corresponding portions of the light pipe perimeter are illuminated in a particular color (quadrants, for example) at a given time. Different quadrants may be simultaneously illuminated in different colors in one example.

**41 Claims, 17 Drawing Sheets**

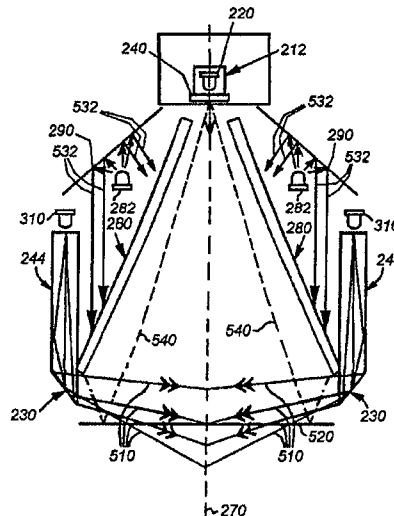

U S PATENT DOCUMENTS

4,766,300 A	8/1988	Chadma et al	5,907,148 A	5/1999	Iwafuchi et al
4,820,911 A	4/1989	Arackellian et al	5,919,057 A	7/1999	Feng
4,894,523 A	1/1990	Chadma et al	5,920,643 A	7/1999	White et al
4,969,037 A	11/1990	Poleschunski et al	5,923,020 A	7/1999	Kurokawa et al
5,019,699 A	5/1991	Koenck	5,969,321 A	10/1999	Arvin et al
5,149,948 A	9/1992	Chusholm	5,979,763 A	11/1999	Wang
5,177,346 A	1/1993	Chusholm	5,984,494 A	11/1999	Chapman et al
5,202,817 A	4/1993	Koenck	5,992,751 A	11/1999	Laser
5,227,614 A	7/1993	Danielson et al	6,011,586 A	1/2000	Leptor et al
5,239,169 A	8/1993	Thomas	6,022,124 A	2/2000	Boum et al
5,258,606 A	11/1993	Chadma et al	6,033,090 A	3/2000	Seo
5,291,009 A	3/1994	Roustaei	6,034,379 A	3/2000	Bunte et al
5,313,373 A	5/1994	Bjorner et al	6,036,095 A	3/2000	Seo
5,319,182 A	6/1994	Havens et al	6,039,254 A	3/2000	Froese-Peeck et al
5,331,176 A	7/1994	San't Anselmo et al	6,039,255 A	3/2000	Seo
5,349,172 A	9/1994	Roustaei	6,042,012 A	3/2000	Omstead et al
5,354,977 A	10/1994	Roustaei	6,045,047 A	4/2000	Pidhury et al
5,359,185 A	10/1994	Hanson	6,060,722 A	5/2000	Havens et al
5,367,439 A	11/1994	Maver et al	6,065,678 A	5/2000	Li et al
5,374,817 A	12/1994	Bard et al	6,073,852 A	6/2000	Seo
5,378,883 A	1/1995	Batterman et al	6,105,869 A	8/2000	Scharf et al
5,406,060 A	4/1995	Gitun	6,119,939 A	9/2000	Schwartz et al
5,408,084 A	4/1995	Brandorff et al	6,141,046 A	10/2000	Roth et al
5,414,251 A	5/1995	Durbn	6,158,661 A	12/2000	Chadma et al
5,422,472 A	6/1995	Tavlsian et al	6,164,544 A	12/2000	Schwartz et al
5,430,285 A	7/1995	Karpen et al	6,210,013 B1	4/2001	Bousfield
5,449,892 A	9/1995	Yamada	6,223,986 B1	5/2001	Bobba et al
5,461,417 A	10/1995	Whirc et al	6,234,397 B1	5/2001	He et al
5,463,214 A	10/1995	Longacre, Jr., et al	6,247,645 B1*	6/2001	Harris et al
5,469,294 A	11/1995	Wilt et al	6,249,008 B1	6/2001	Bunte et al
5,481,098 A	1/1996	Davis et al	6,250,551 B1	6/2001	He et al
5,484,994 A	1/1996	Roustaei	6,260,763 B1	7/2001	Svetal
5,500,516 A	3/1996	Durbn	6,267,294 B1	7/2001	Stern et al
5,504,317 A	4/1996	Takahashi	6,283,374 B1	9/2001	Fantone et al
5,504,367 A	4/1996	Wang et al	6,340,114 B1	1/2002	Correa et al
5,514,858 A	5/1996	Ackley	6,341,878 B1	1/2002	Chiang
5,515,452 A	5/1996	Penkethman et al	6,347,163 B2	2/2002	Roustaei et al
5,532,467 A	7/1996	Roustaei et al	6,347,163 B2	2/2002	Boyd et al
5,569,902 A	10/1996	Wood et al	6,347,874 B1	2/2002	Hattersley et al
5,585,616 A	12/1996	Roxby et al	6,360,948 B1	3/2002	Yang et al
5,586,212 A	12/1996	McConica et al	6,371,374 B1	4/2002	Schwartz et al
5,591,955 A	1/1997	Laser	6,385,352 B1	5/2002	Roustaei
5,598,007 A	1/1997	Bunce et al	6,385,507 B1	5/2002	Buijts et al
5,606,160 A	2/1997	Tam et al	6,394,349 B1	5/2002	Shgekusa et al
5,619,029 A	4/1997	Roxby et al	6,405,925 B2	6/2002	He et al
5,623,137 A	4/1997	Powers et al	6,429,934 B1*	8/2002	Dunn et al
5,654,540 A	8/1997	Stanton et al	6,435,411 B1	8/2002	Massieu et al
5,659,167 A	8/1997	Wang et al	6,491,223 B1	12/2002	Longacre et al
5,684,290 A	11/1997	Arackellian et al	6,505,778 B1	1/2003	Reddersen et al
5,696,321 A	12/1997	Danielson et al	6,513,714 B1	2/2003	Davis et al
5,697,699 A	12/1997	Seo et al	6,547,146 B1	4/2003	Meksavan et al
5,703,348 A	12/1997	Suzuki et al	6,575,367 B1	6/2003	Longacre, Jr
5,715,095 A	2/1998	Hiratsuka et al	6,581,838 B1	6/2003	Meksavan et al
5,723,868 A	3/1998	Hammond et al	6,592,040 B2	7/2003	Barkan
5,734,153 A	3/1998	Swartz et al	6,595,422 B1	7/2003	Doljack
5,743,633 A	4/1998	Chau et al	6,598,797 B2	7/2003	Lee
5,756,981 A	5/1998	Roustaei et al	6,601,768 B2	8/2003	McCall et al
5,773,810 A	6/1998	Hussey et al	6,607,128 B1	8/2003	Schwartz et al
5,777,314 A	7/1998	Roustaei	6,607,132 B1	8/2003	Dvorikis et al
5,780,834 A	7/1998	Havens et al	6,621,065 B1	9/2003	Fukunoto et al
5,783,811 A	7/1998	Feng et al	6,659,350 B2	12/2003	Schwartz et al
5,786,586 A	7/1998	Pidhury et al	6,661,521 B1	12/2003	Stern
5,793,033 A	8/1998	Feng et al	6,681,037 B1	1/2004	Koljonen
5,811,784 A	9/1998	Tausch et al	6,689,998 B1	2/2004	Bremer
			6,729,546 B2	5/2004	Roustaei
			6,760,165 B2	7/2004	Wulff et al
			6,802,088 B2	10/2004	K...

235/454

356/244

## US 7,874,487 B2

Page 3

6,914,679 B2	7/2005	Nettekoven et al.	2008/0170380 A1	7/2008	Pastore
7,021,542 B2	4/2006	Patel et al.	FOREIGN PATENT DOCUMENTS		
7,025,271 B2	4/2006	Dvorkis et al.			
7,025,272 B2	4/2006	Yavid et al.	DE	3737792	5/1989
7,025,273 B2	4/2006	Breytman et al.	DE	3931044	3/1991
7,025,572 B2	4/2006	Dimitry et al.	DE	4003983	8/1991
7,038,853 B2	5/2006	Li et al.	DE	4003983 C1	8/1991
7,044,377 B2	5/2006	Patel et al.	DE	4123916	1/1992
7,090,132 B2	8/2006	Havens et al.	DE	4123916 A1	1/1992
7,128,266 B2	10/2006	Zhu et al.	DE	10113426	3/2001
7,131,587 B2	11/2006	He et al.	DE	10026301	11/2001
7,159,764 B1	1/2007	White et al.	DE	10026301 A1	11/2001
7,163,149 B2	1/2007	He et al.	EP	0185782	3/1989
7,187,825 B2	3/2007	Lim et al.	EP	0356680	3/1990
7,204,418 B2	4/2007	Josep et al.	EP	1158460	11/2001
7,204,420 B2	4/2007	Barken et al.	EP	05043449	5/2005
7,180,052 B1	5/2007	Barkan et al.	JP	S53-62387	6/1978
7,224,540 B2	5/2007	Olmstead et al.	JP	H3-53784	3/1991
7,240,844 B2	7/2007	Zhu et al.	JP	H353784	3/1991
7,253,384 B2	8/2007	Barnes et al.	JP	04-223583	8/1992
7,267,282 B2	9/2007	Zhu et al.	JP	06-124361	5/1994
7,270,274 B2	9/2007	Hennick et al.	JP	6124361	5/1994
7,278,575 B2	10/2007	Zhu et al.	JP	08-129597	5/1996
7,281,661 B2	10/2007	Zhu et al.	JP	08-287176	11/1996
7,296,749 B2	11/2007	Massieu	JP	10134133	5/1998
7,306,155 B2	12/2007	Hennick et al.	JP	2000-231600	8/2000
7,314,173 B2	1/2008	Philyaw et al.	JP	2001-307011	11/2001
7,331,524 B2	2/2008	Vinogradov et al.	JP	2007-028088	1/2007
7,360,705 B2	4/2008	Heinrich	JP	200728088	1/2007
7,451,917 B2	11/2008	McCall et al.	JP	200728088 A	1/2007
7,490,774 B2	2/2009	Zhu et al.	WO	91/12489	8/1991
7,520,434 B2	4/2009	Jolivet et al.	WO	9112489	8/1991
7,568,628 B2	8/2009	Wang et al.	WO	9216909 A1	10/1992
7,604,174 B2	10/2009	Gerst et al.	WO	9949347	9/1999
2001/0027999 A1	10/2001	Lee	WO	0016073	3/2000
2002/0000472 A1	1/2002	Hattersley et al.	WO	0163258	8/2001
2002/0030094 A1	3/2002	Curry et al.	WO	0165469 A1	9/2001
2002/0074403 A1	6/2002	Krichever et al.	WO	02075637	9/2002
2002/0125322 A1	9/2002	McCall et al.	WO	02075637 A1	9/2002
2002/0170970 A1	11/2002	Ehrhart	WO	04006438	1/2004
2003/0001018 A1	1/2003	Hussey et al.	OTHER PUBLICATIONS		
2003/0029917 A1	2/2003	Hennick et al.			
2003/0034394 A1	2/2003	Gannon et al.	Cognex Corporation, AcuReader/OCR, Accurate, Fast Wafer Identification, 1995-1996.		
2003/0058631 A1	3/2003	Yoneda	Cognex Corporation, 50mm Ring Light Image Formation System, For the In-Sight 5000 series ID Readers, 2006.		
2003/0062413 A1	4/2003	Gardiner et al.	Cognex Corporation, Diffuse Ring Light Installation Instructions, In-Sight, 2006.		
2003/0062418 A1	4/2003	Barber et al.	Cognex Corporation, DataMan Handheld ID Readers, 2005.		
2003/0080187 A1	5/2003	Piva et al.	Cognex Corporation, DataMan 6500 Series, Quick Reference Guide, Aug. 2004.		
2003/0080189 A1	5/2003	Patel et al.	Vision-Supplies.com, Siemens LytePipe 1.5 x 30, 1999.		
2003/0163623 A1	8/2003	Yeung	PCT Search Report, PCT/US2004/034389, pp. 1-18, dated May 2, 2005.		
2004/0069855 A1	4/2004	Patel et al.	PCT Search Report, PCT/US2004/034872, pp. 1-19, dated Feb. 24, 2005.		
2004/0156539 A1	8/2004	Jansson et al.	PCT Search Report, PCT/US2005/044466, pp. 1-15, dated Apr. 12, 2006.		
2004/0217173 A1	11/2004	Lizotte et al.	PCT Search Report, PCT/US2006/041041, pp. 1-8, dated May 25, 2007.		
2004/0238637 A1	12/2004	Russell et al.	Japanese Patent Office Action, Application No. 2006-536784, pp. 1-9, dated Oct. 6, 2009.		
2005/0029439 A1	2/2005	Benedict	U.S. Patent Office Notice of Allowance for U.S. Appl. No. 10/911,989, pp. 1-7, dated Jun 3, 2009.		
2005/0045725 A1	3/2005	Gurevich et al.	U.S. Patent Office Non-Final Office Action for U.S. Appl. No. 10/911,989, pp. 1-11, dated Oct. 17, 2008.		
2005/0047723 A1	3/2005	Li	U.S. Patent Office Final Office Action for U.S. Appl. No. 10/911,989, pp. 1-11, dated Sep. 26, 2007.		
2005/0087601 A1 *	4/2005	Gerst et al. .... 235/455	U.S. Patent Office Non-Final Office Action for U.S. Appl. No. 10/911,989, pp. 1-11, dated Feb. 21, 2007.		
2005/0117144 A1	6/2005	Greenway et al.	U.S. Patent Office Notice of Allowance for U.S. Appl. No. 10/693,626, pp. 1-7, dated Dec. 21, 2009.		
2005/0180037 A1	8/2005	Masterson			
2005/0199725 A1	9/2005	Caraen et al.			
2006/0027657 A1	2/2006	Nunnink et al.			
2006/0027659 A1	2/2006	Patel et al.			
2006/0032921 A1 *	2/2006	Gerst et al. .... 235/455			
2006/0060653 A1	3/2006	Wittenberg et al.			
2006/0131419 A1	6/2006	Nunnink			
2006/0133757 A1	6/2006	Nunnink			
2006/0266840 A1	11/2006	Vinogradov et al.			
2007/0090193 A1	4/2007	Nunnink et al.			
2007/0091332 A1	4/2007	Nunnink			
2007/0152064 A1	7/2007	Nunnink			
2007/0206183 A1	9/2007	Lebens			

## US 7,874,487 B2

Page 4

- U.S. Patent Office Final Office Action for U.S. Appl. No. 10/693,626, pp. 1-17, dated Feb. 22, 2008.
- U.S. Patent Office Non-Final Office Action for U.S. Appl. No. 10/693,626, pp. 1-9, dated Jul. 26, 2007.
- U.S. Patent Office Final Office Action for U.S. Appl. No. 10/693,626, pp. 1-10, dated Dec. 1, 2006.
- U.S. Patent Office Non-Final Office Action for U.S. Appl. No. 10/693,626, pp. 1-9, dated Jun. 15, 2006.
- U.S. Patent Office Non-Final Office Action for U.S. Appl. No. 10/693,626, pp. 1-9, dated Dec. 13, 2005.
- U.S. Patent Office Non-Final Office Action for U.S. Appl. No. 10/693,626, pp. 1-9, dated Jun. 28, 2005.
- U.S. Patent Office Non-Final Office Action for U.S. Appl. No. 10/693,626, pp. 1-11, dated Oct. 17, 2008.
- U.S. Patent Office Notice of Allowance for U.S. Appl. No. 11/019,763, pp. 1-6, dated Aug. 11, 2009.
- U.S. Patent Office Ex Parte Quayle Action for U.S. Appl. No. 11/019,763, pp. 1-5, dated Apr. 16, 2009.
- U.S. Patent Office Notice of Allowance for U.S. Appl. No. 11/019,763, pp. 1-6, dated Nov. 5, 2008.
- U.S. Patent Office Non-Final Office Action for U.S. Appl. No. 11/019,763, pp. 1-6, dated Apr. 11, 2008.
- U.S. Patent Office Final Office Action for U.S. Appl. No. 11/019,763, pp. 1-8, dated Nov. 27, 2007.
- U.S. Patent Office Non-Final Office Action for U.S. Appl. No. 11/019,763, pp. 1-7, dated Jun. 12, 2007.
- U.S. Patent Office Notice of Allowance for U.S. Appl. No. 11/322,370, pp. 1-7, dated Dec. 12, 2009.
- U.S. Patent Office Notice of Allowance for U.S. Appl. No. 11/322,370, pp. 1-8, dated Jun. 30, 2009.
- U.S. Patent Office Non-Final Office Action for U.S. Appl. No. 11/322,370, pp. 1-11, dated Nov. 25, 2008.
- U.S. Patent Office Examiner Interview Summary for U.S. Appl. No. 11/322,370, pp. 1-2, dated Nov. 13, 2008.
- U.S. Patent Office Final Office Action for U.S. Appl. No. 11/322,370, pp. 1-8, dated Sep. 5, 2008.
- U.S. Patent Office Non-Final Office Action for U.S. Appl. No. 11/322,370, pp. 1-7, dated Jan. 7, 2008.
- U.S. Patent Office Examiner Interview Summary for U.S. Appl. No. 11/322,370, p. 1, dated Dec. 12, 2007.
- U.S. Patent Office Final Office Action for U.S. Appl. No. 11/322,370, pp. 1-9, dated Oct. 4, 2007.
- U.S. Patent Office Non-Final Office Action for U.S. Appl. No. 11/322,370, pp. 1-10, dated Mar. 16, 2007.
- CCS Inc., LFX-series Lights, <http://www.ccs-inc.co.jp/cgi-bin/hp.cgi?menu=102-115-01e>, Feb. 12, 2009.
- Cognex Corporation, DataMan 6500 Series, Quick Reference, 2004.
- Cognex Corporation, DataMan 7500 Series, Handheld Models, Cognex Machine Vision System and Machine Vision Sensors, 2009.
- InData Systems, 441OLDS Hand Held Etched 2D Image Reader, 27 Fennell Street, Skaneateles, NY 13152, Internet: [www.indatasys.com](http://www.indatasys.com), Jan. 1, 2005.
- Chinese Patent Office Action, Application No. 2006-80048666.8, pp. 1-9, dated Mar. 19, 2010.
- U.S. Patent Office Non-Final Office Action for U.S. Appl. No. 11/014,478, pp. 1-8, dated Jan. 24, 2006.
- U.S. Patent Office Non-Final Office Action for U.S. Appl. No. 11/321,702, pp. 1-7, dated Jun. 25, 2008.
- U.S. Patent Office Non-Final Office Action for U.S. Appl. No. 12/573,402, pp. 1-8, dated May 25, 2010.
- PCT Search Report, PCT/US2005/044452, pp. 1-6, dated Dec. 16, 2004.
- German Patent Office Office Action on German patent No. 10291122.3, Apr. 29, 2010.

\* cited by examiner

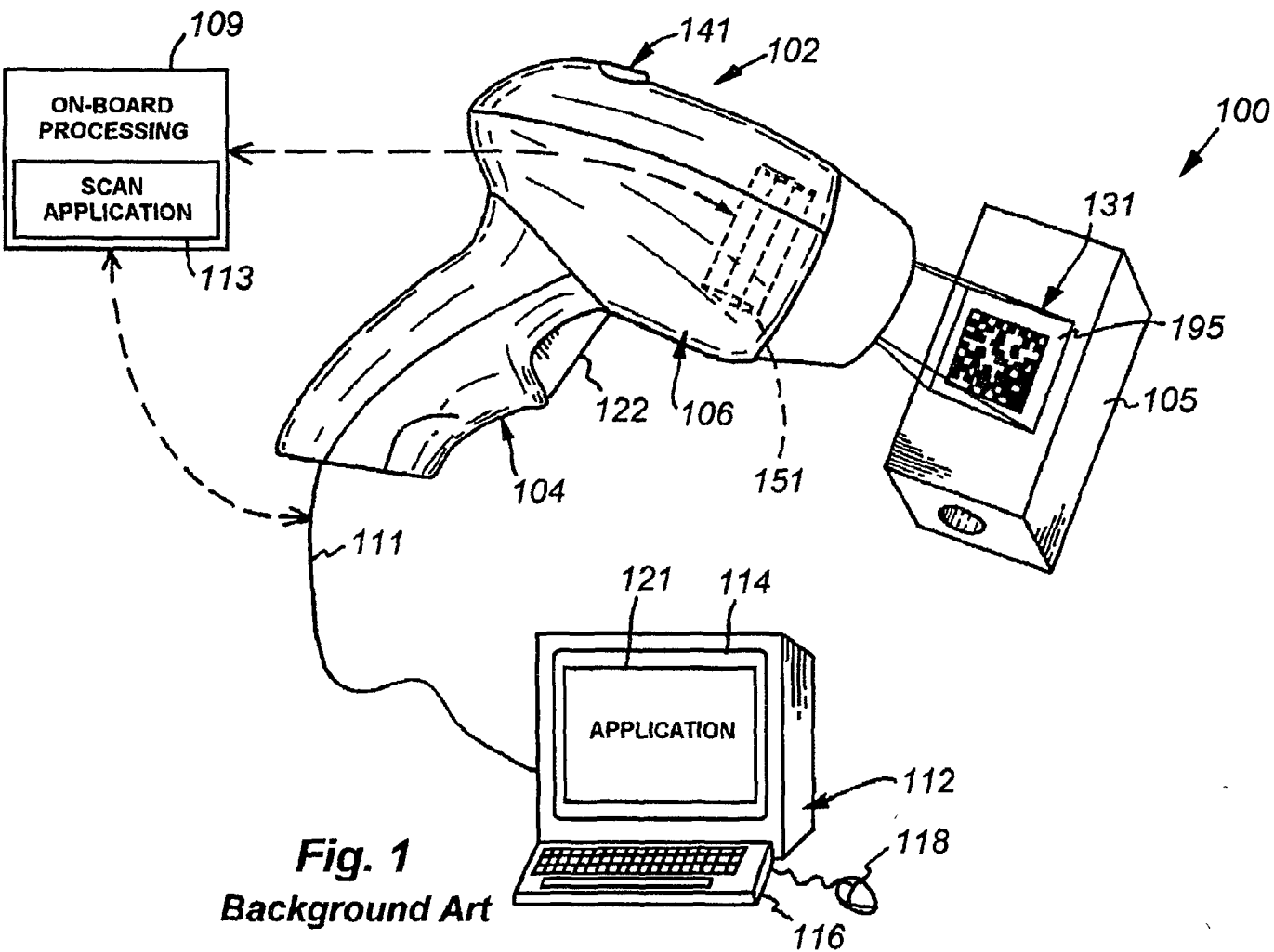

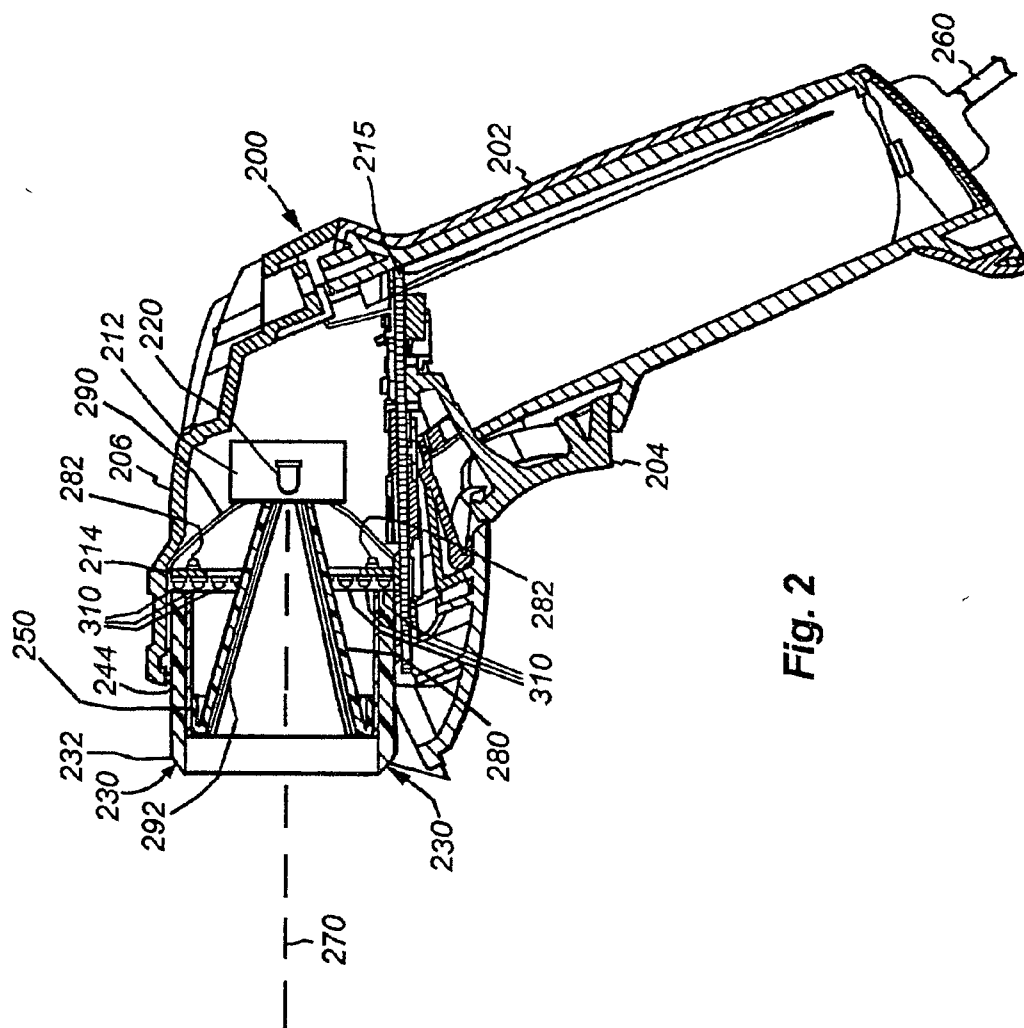

Fig. 2

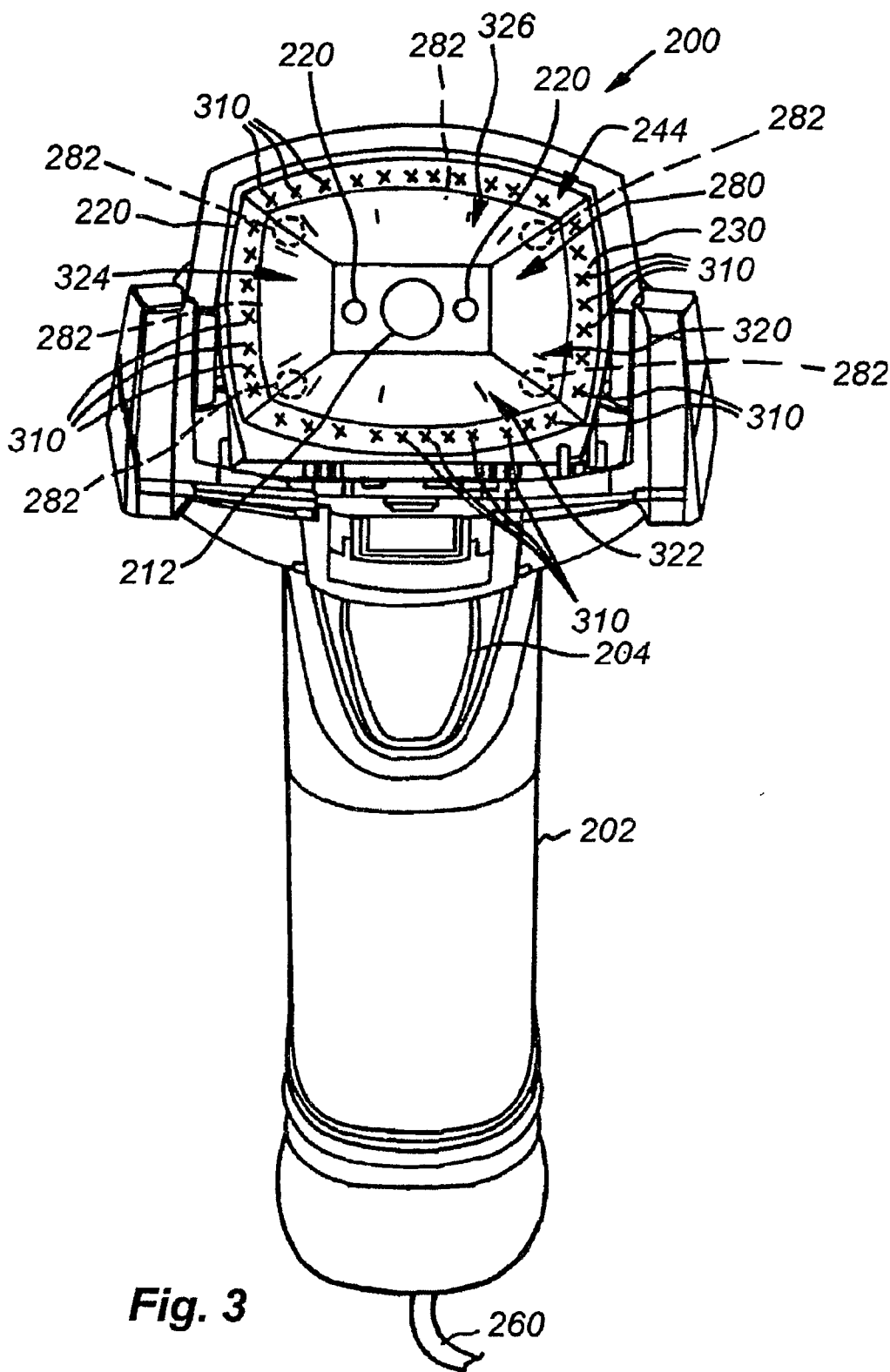

Fig. 3





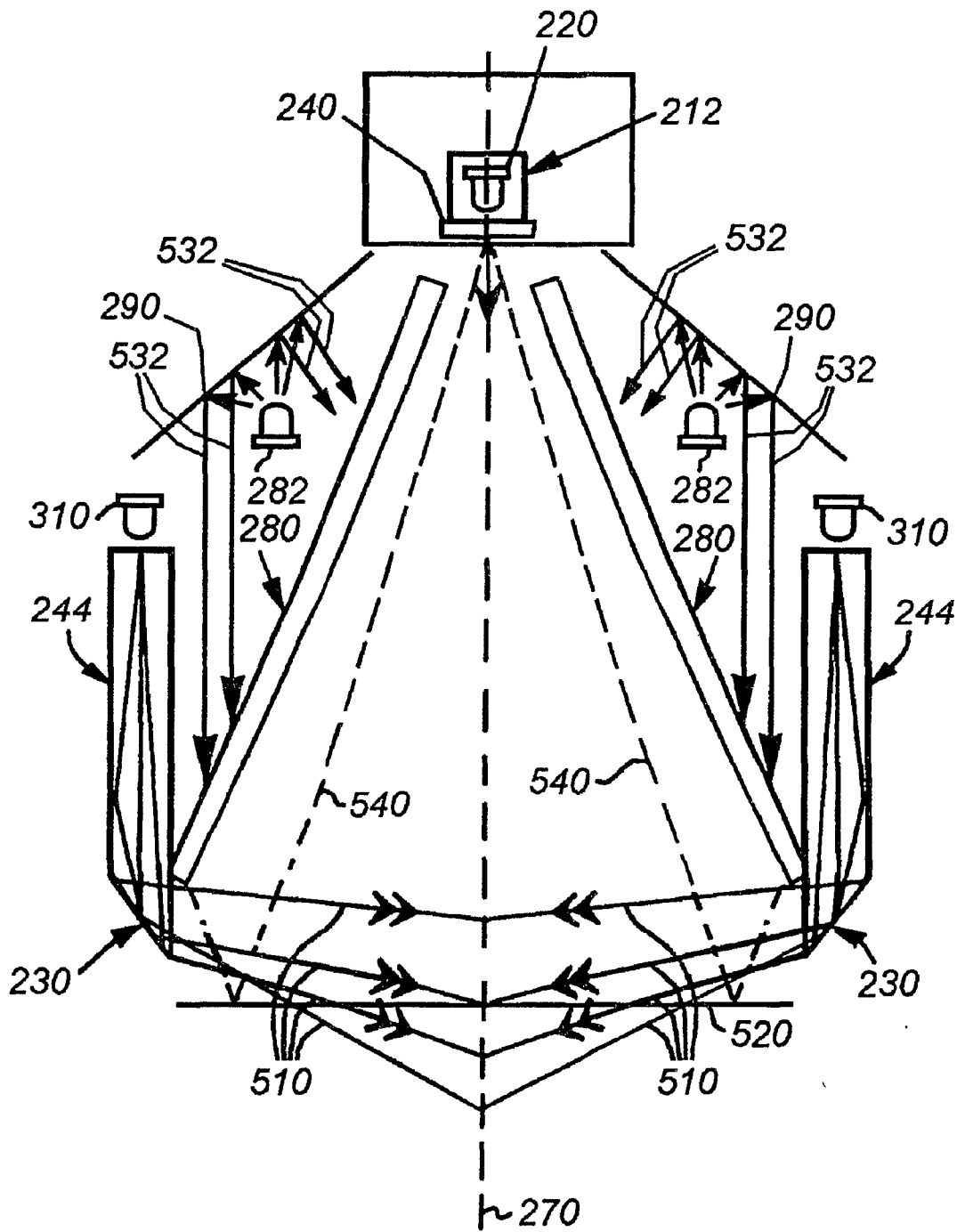
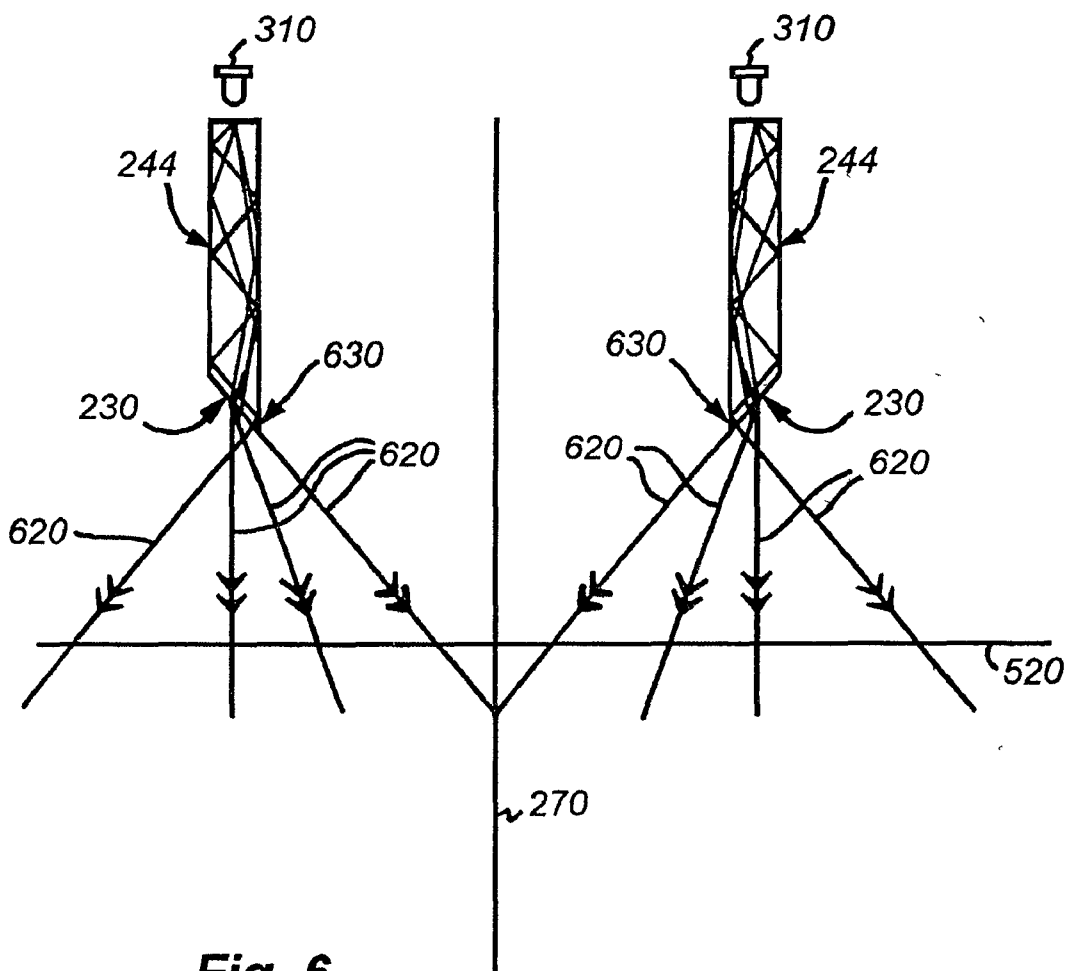
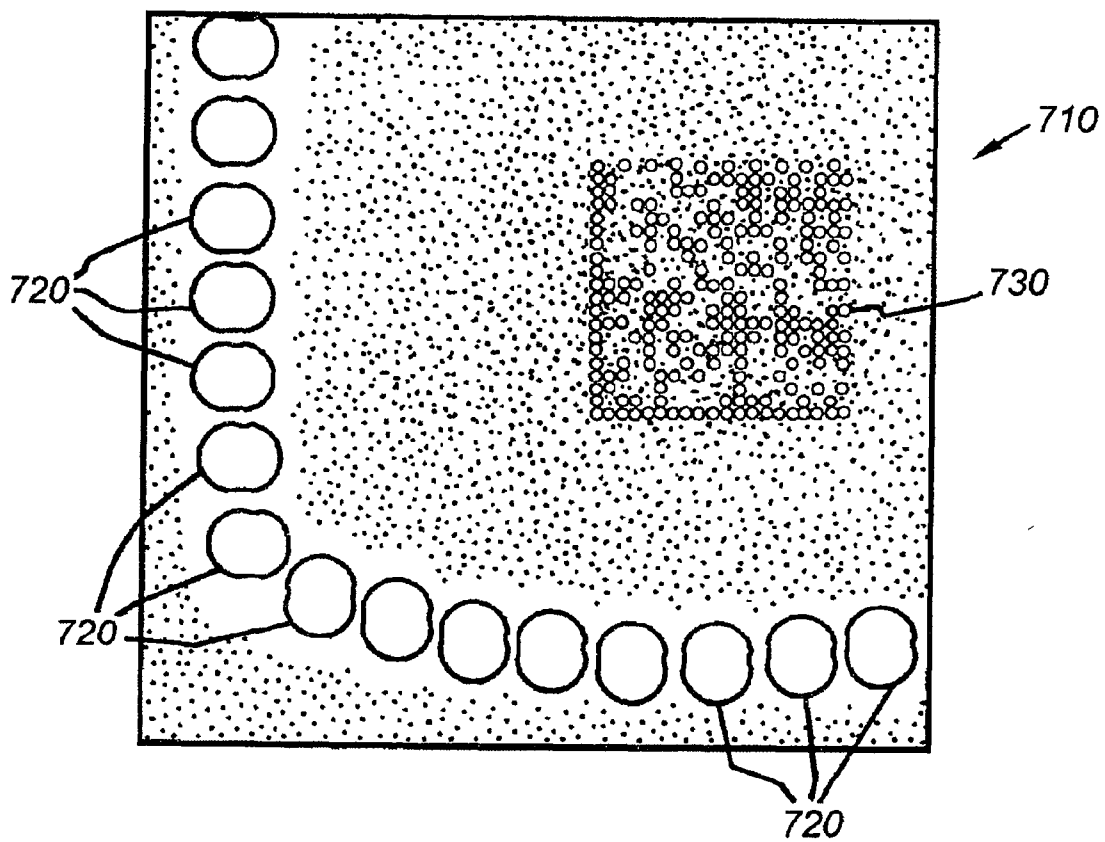

Fig. 5



**Fig. 6**



**Fig. 7**

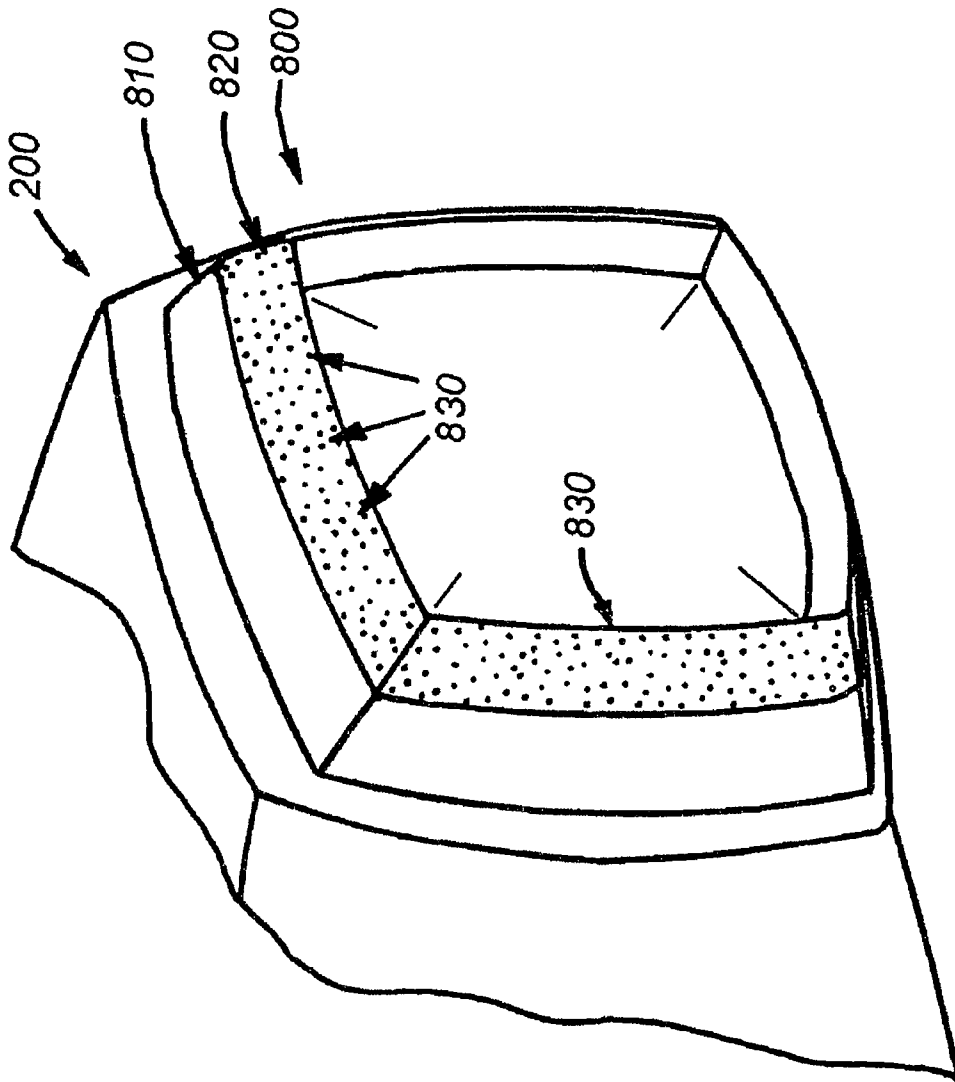
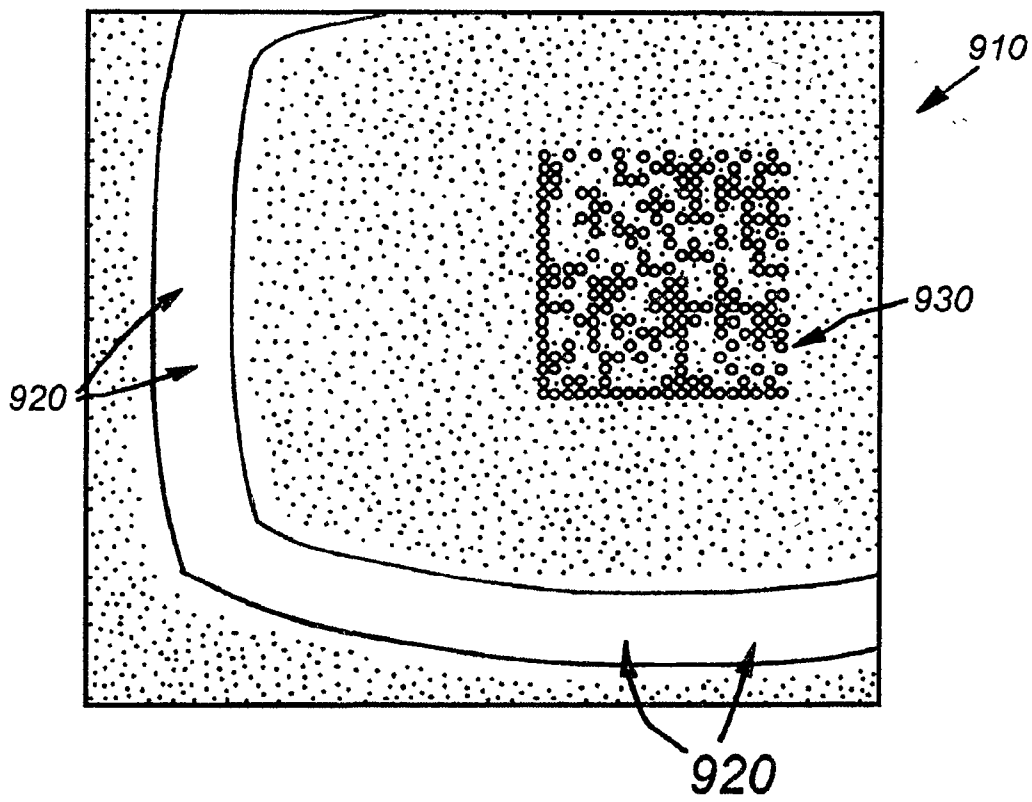

Fig. 8



**Fig. 9**

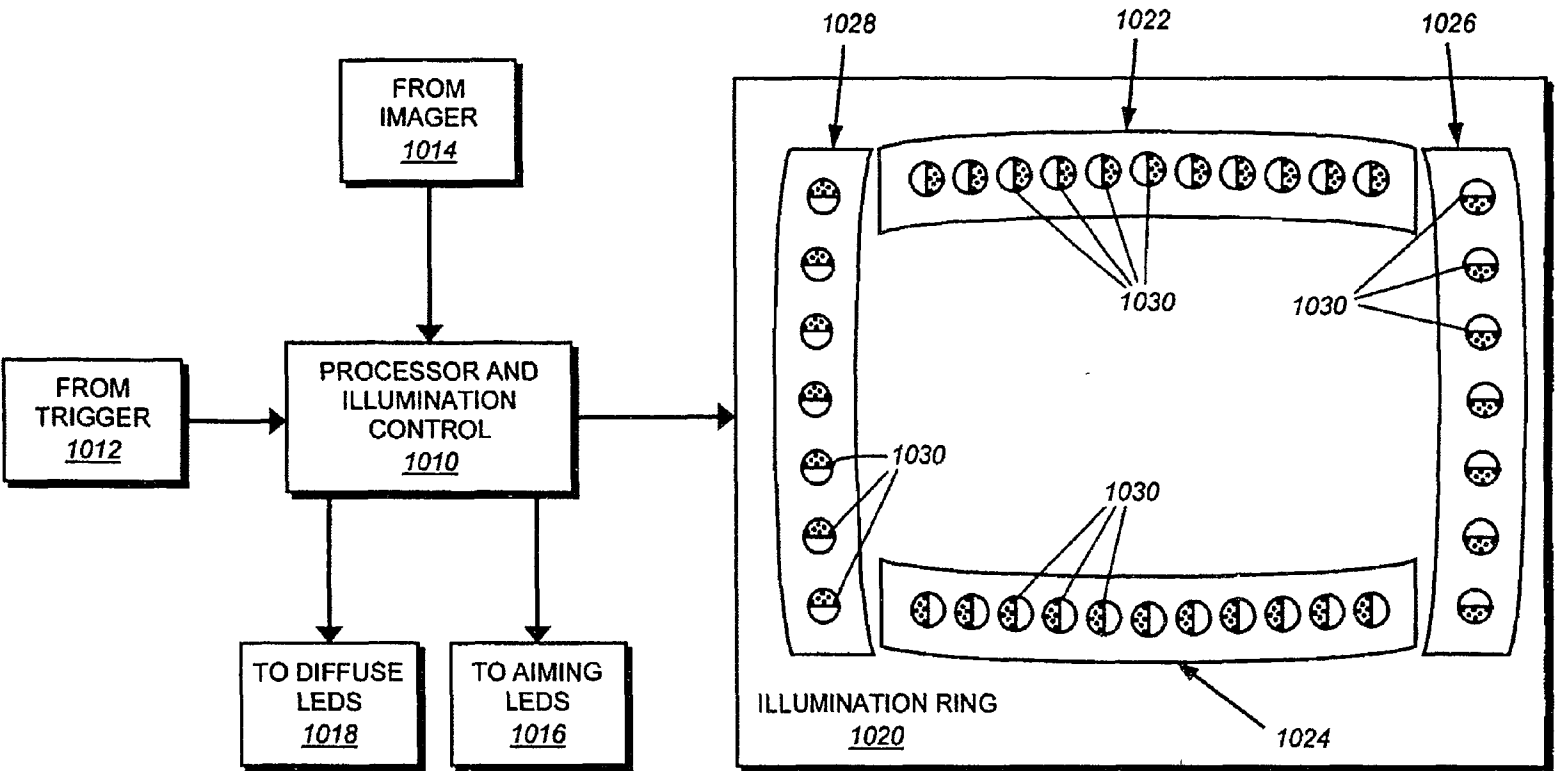

FIG. 10

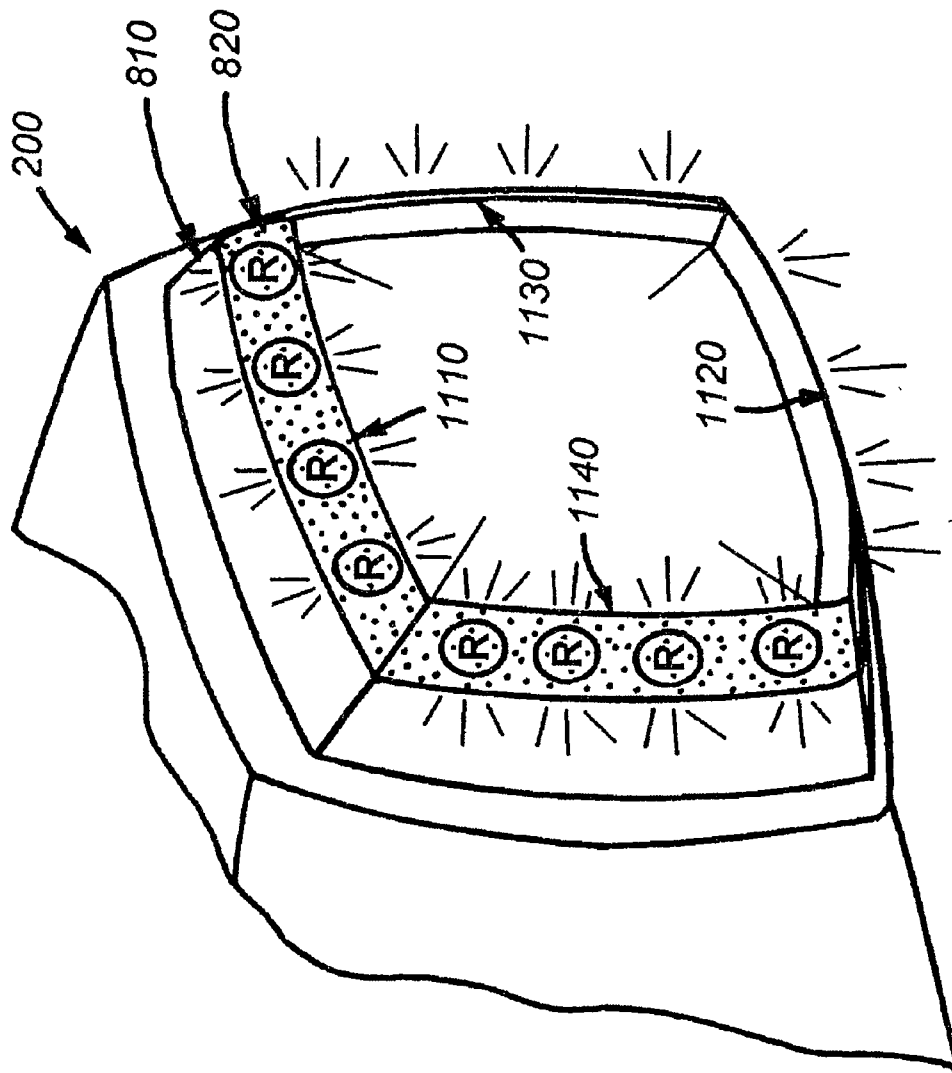

Fig. 11

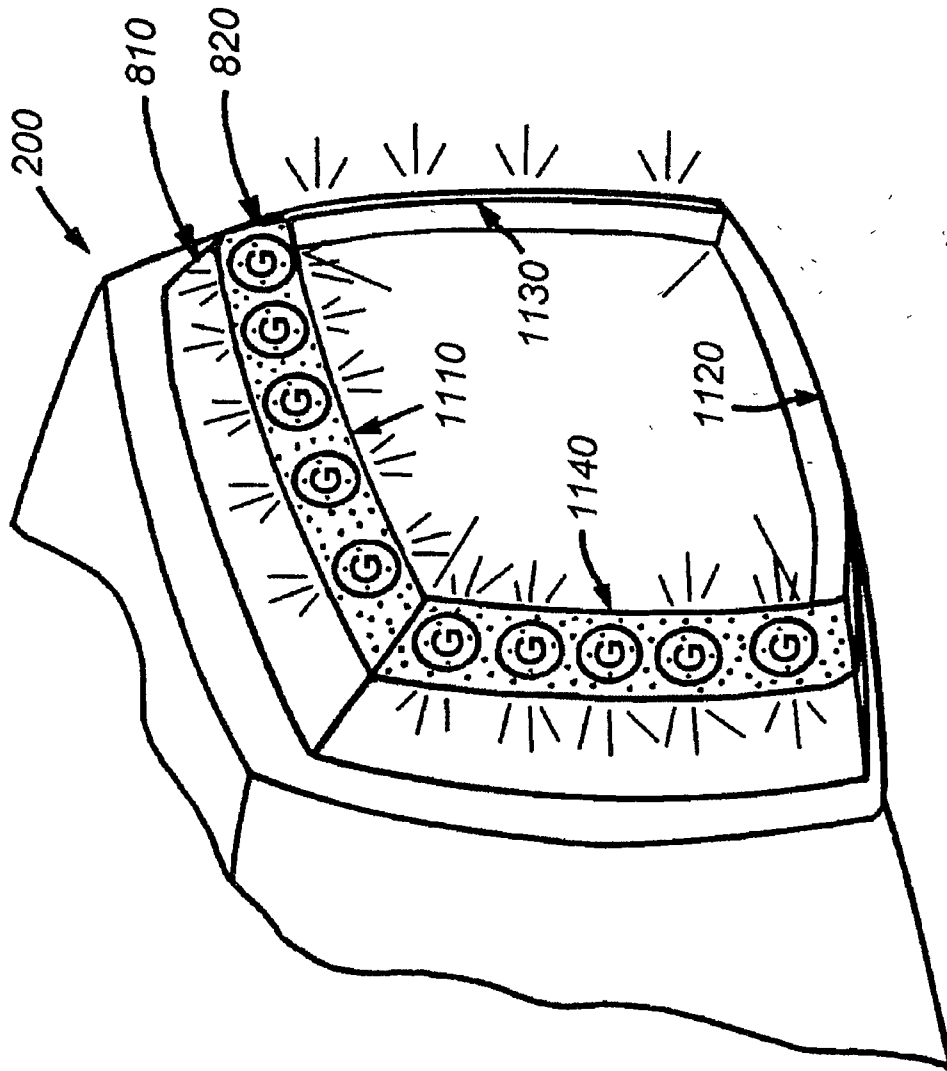

Fig. 12



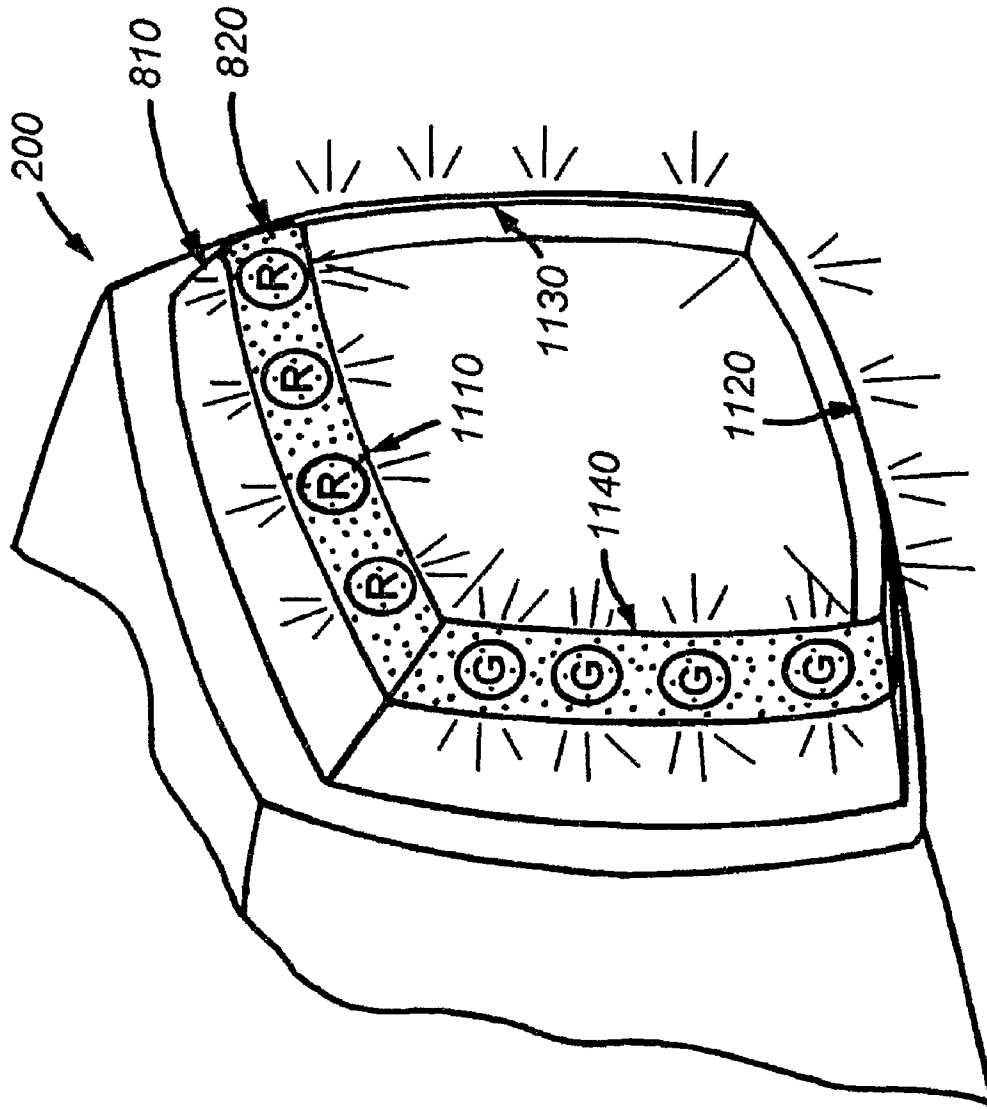
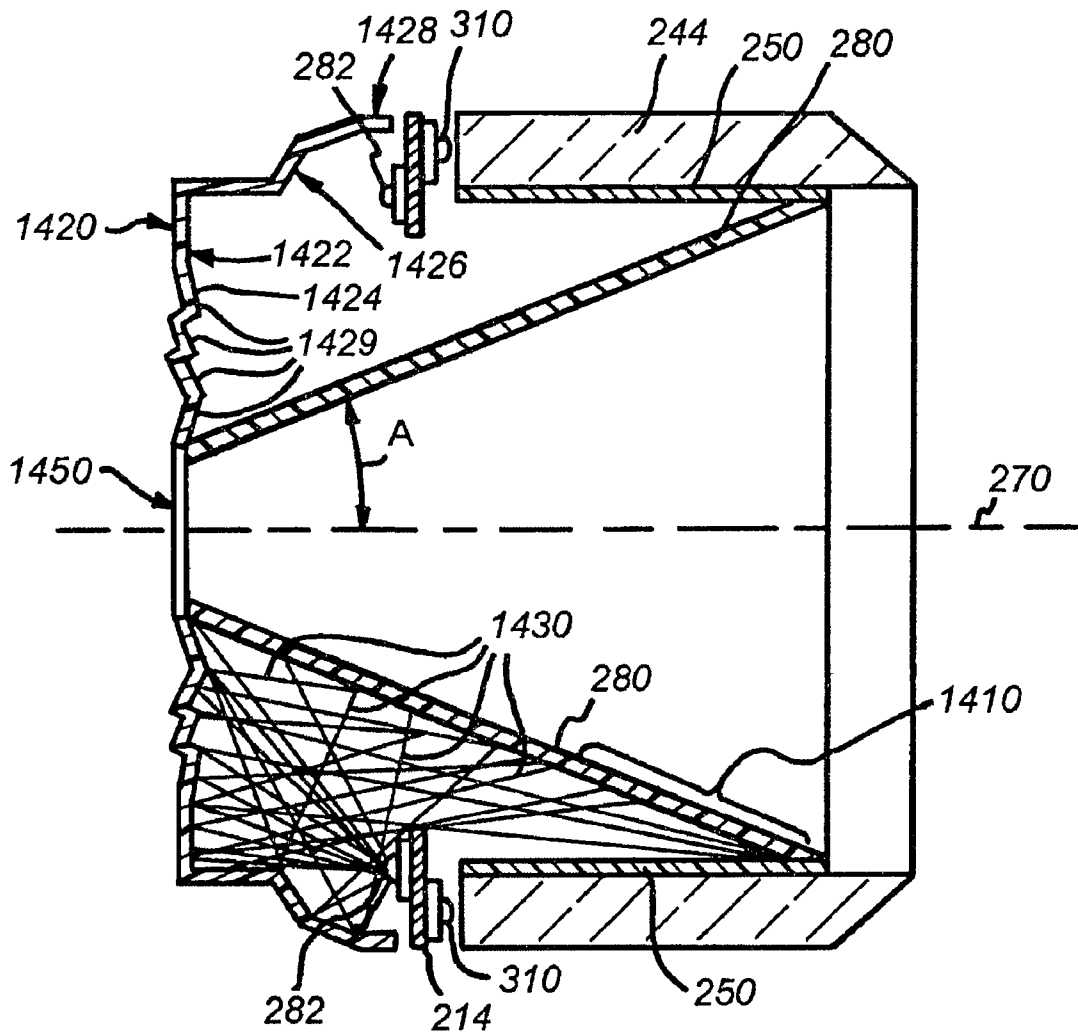
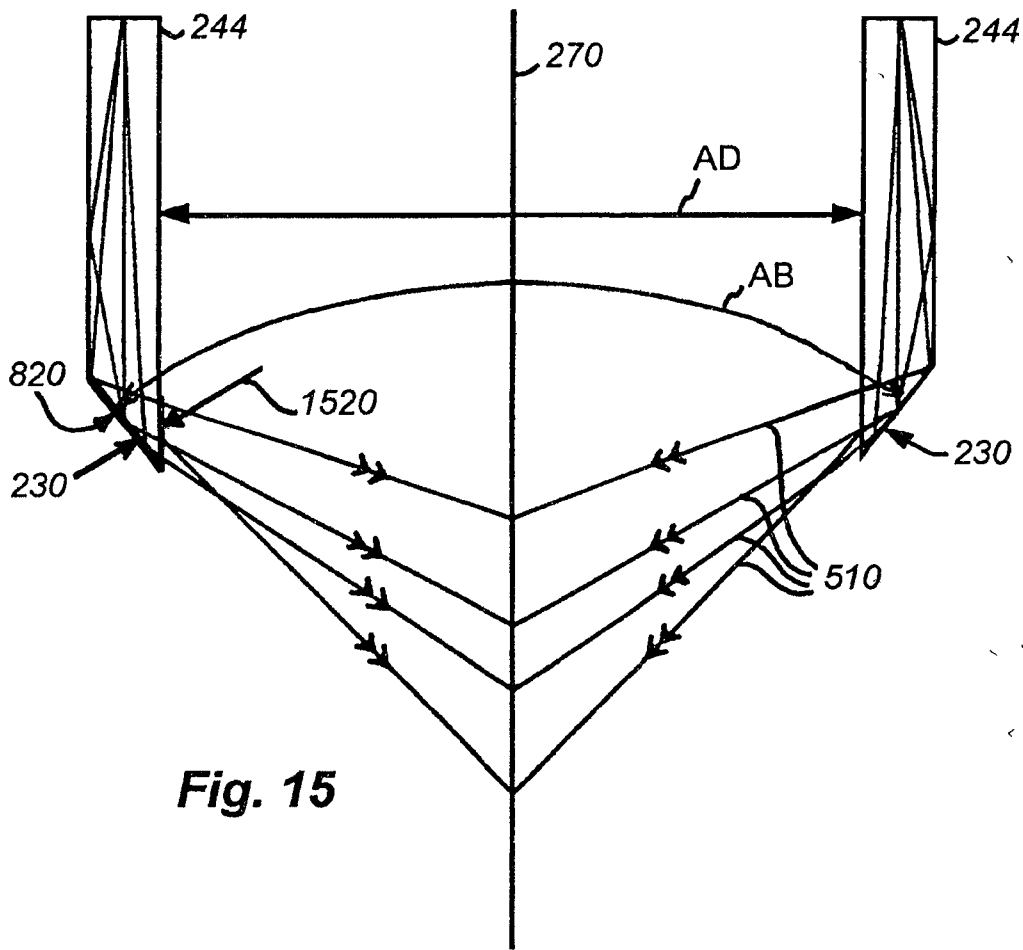
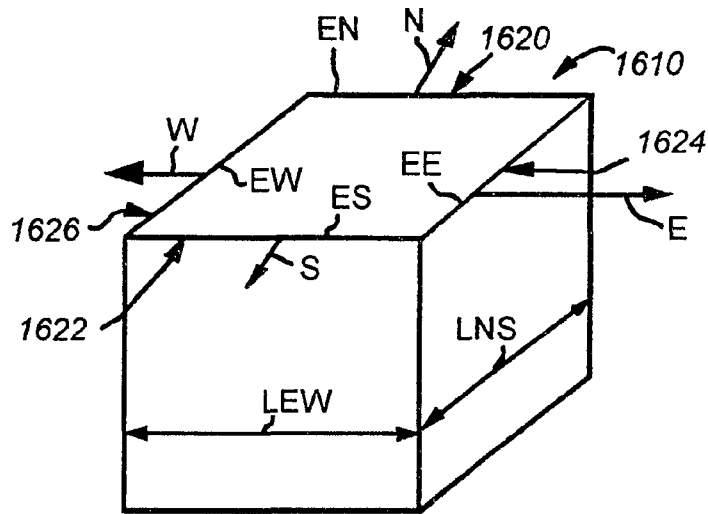

Fig. 13

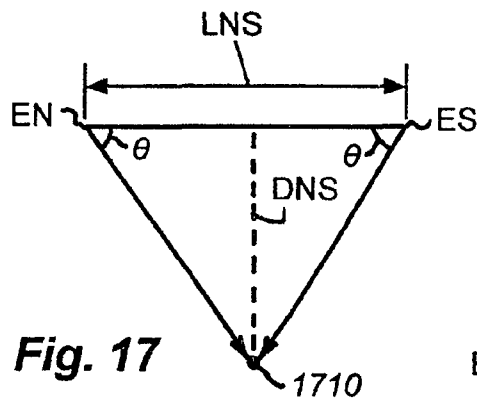

**Fig. 14**

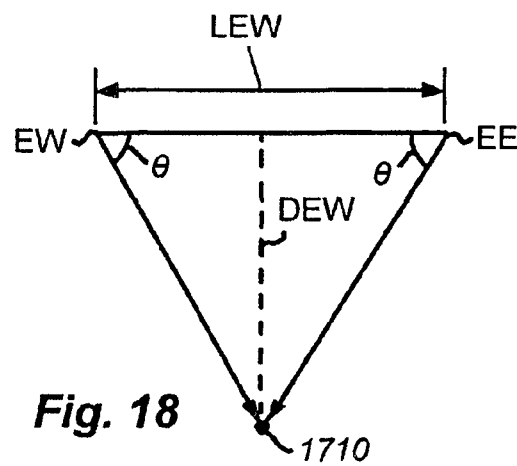



**Fig. 16**



**Fig. 17**



**Fig. 18**

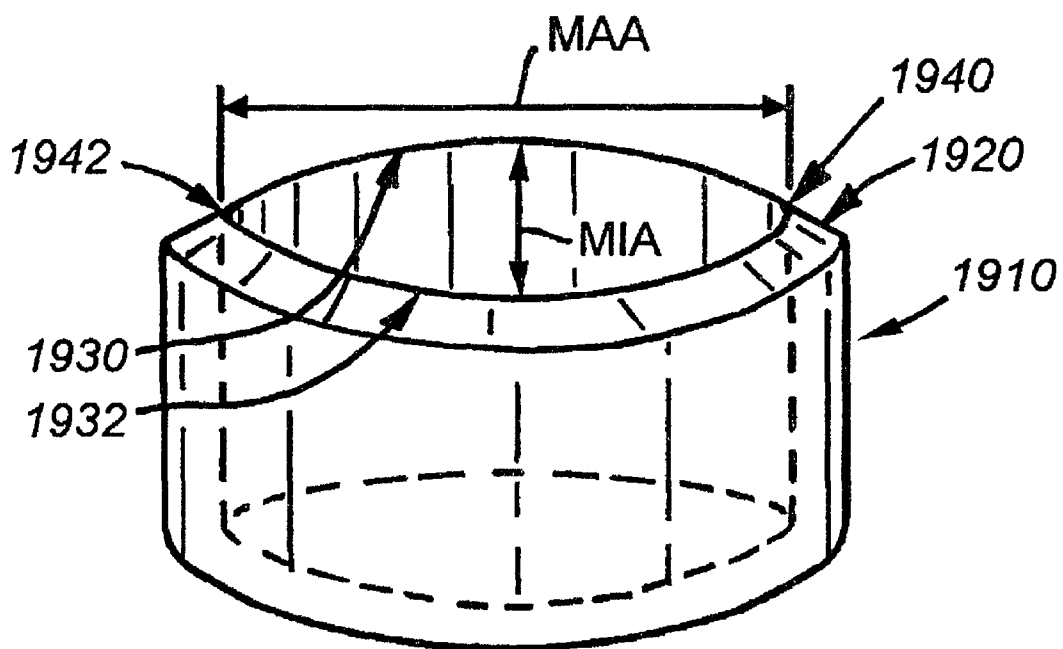

**Fig. 19**

US 7,874,487-B2

1

## INTEGRATED ILLUMINATION ASSEMBLY FOR SYMBOLOGY READER

### BACKGROUND OF THE INVENTION

#### 1. Field of the Invention

This invention relates to machine vision systems and symbology readers that employ machine vision and more particularly to illuminators for the same.

#### 2. Background Information

Machine vision systems use image acquisition devices that include camera sensors to deliver information on a viewed subject. The system then interprets this information according to a variety of algorithms to perform a programmed decision-making and/or identification function. For an image to be most-effectively acquired by a sensor in the visible, and near-visible light range, the subject should be properly illuminated.

In the example of symbology reading (also commonly termed "barcode" scanning) using an image sensor, proper illumination is highly desirable. Symbology reading entails the aiming of an image acquisition sensor (CMOS camera, CCD, etc.) at a location on an object that contains a symbol (a "barcode"), and acquiring an image of that symbol. The symbol contains a set of predetermined patterns that represent an ordered group of characters or shapes from which an attached data processor (for example, a microcomputer) can derive useful information about the object (e.g. its serial number, type, model, price, etc.). Symbols/barcodes are available in a variety of shapes and sizes. Two of the most commonly employed symbol types used in marking and identifying objects are the so-called one-dimensional barcode, consisting of a line of vertical stripes of varying width and spacing, and the so-called two-dimensional barcode consisting of a two-dimensional array of dots or rectangles.

By way of background FIG. 1 shows an exemplary scanning system 100 adapted for handheld operation. An exemplary handheld scanning appliance or handpiece 102 is provided. It includes a grip section 104 and a body section 106. An image formation system 151, shown in phantom, can be controlled and can direct image data to an on-board embedded processor 109. This processor can include a scanning software application 113 by which lighting is controlled, images are acquired and image data is interpreted into usable information (for example, alphanumeric strings derived from the symbols (such as the depicted two-dimensional barcode image 195). The decoded information can be directed via a cable 111 to a PC or other data storage device 112 having (for example) a display 114, keyboard 116 and mouse 118, where it can be stored and further manipulated using an appropriate application 121. Alternatively, the cable 111 can be directly connected to an interface in the scanning appliance and an appropriate interface in the computer 112. In this case the computer-based application 121 performs various image interpretation/decoding and lighting control functions as needed. The precise arrangement of the handheld scanning appliance with respect to an embedded processor, computer or other processor is highly variable. For example, a wireless interconnect can be provided in which no cable 111 is present. Likewise, the depicted microcomputer can be substituted with another processing device, including an onboard processor or a miniaturized processing unit such as a personal digital assistant or other small-scale computing device.

The scanning application 113 can be adapted to respond to inputs from the scanning appliance 102. For example, when the operator toggles a trigger 122 on the hand held scanning appliance 102, an internal camera image sensor (that is part of

2

the image formation system 151) acquires an image of a region of interest 131 on an object 105. The exemplary region of interest includes a two-dimensional symbol 195 that can be used to identify the object 105. Identification and other processing functions are carried out by the scanning application 113, based upon image data transmitted from the hand held scanning appliance 102 to the processor 109. A visual indicator 141 can be illuminated by signals from the processor 109 to indicate a successful read and decode of the symbol 195.

In reading symbology or other subjects of interest, the type of illumination employed is of concern. Where symbology and/or other viewed subjects are printed on a flat surface with contrasting ink or paint, a diffuse, high-angle "bright field" illumination may best highlight these features for the sensor. By high-angle it is meant, generally, light that strikes the subject nearly perpendicularly (normal) or at an angle that is typically no more than about 45 degrees from perpendicular (normal) to the surface of the item being scanned. Such illumination is subject to substantial reflection back toward the sensor. By way of example, barcodes and other subjects requiring mainly bright field illumination may be present on a printed label adhered to an item or container, or on a printed field in a relatively smooth area of item or container.

Conversely, where a symbology or other subject is formed on a more-irregular surface, or is created by etching or peening a pattern directly on the surface, the use of highly reflective bright field illumination may be inappropriate. A peened/etched surface has two-dimensional properties that tend to scatter bright field illumination, thereby obscuring the acquired image. Where a viewed subject has such decidedly two-dimensional surface texture, it may be best illuminated with dark field illumination. This is an illumination with a characteristic low angle (approximately 45 degrees or less, for example) with respect to the surface of the subject (i.e. an angle of more than approximately 45 degrees with respect to normal). Using such low-angle, dark field illumination, two-dimensional surface texture is contrasted more effectively (with indents appearing as bright spots and the surroundings as shadow) for better image acquisition.

In other instances of applied symbology a diffuse direct illumination may be preferred. Such illumination is typically produced using a direct-projected illumination source (e.g. light emitting diodes (LEDs)) that passes through a diffuser to generate the desired illumination effect.

To take full advantage of the versatility of a camera image sensor, it is desirable to provide bright field, dark field and diffuse illumination. However, dark field illumination must be presented close to a subject to attain the low incidence angle thereto. Conversely, bright field illumination is better produced at a relative distance to ensure full area illumination.

Commonly assigned U.S. patent application Ser. No. 11/014,478, entitled HAND HELD SYMBOLOGY READER ILLUMINATION DIFFUSER and U.S. patent application Ser. No. 11/019,763, entitled LOW PROFILE ILLUMINATION FOR DIRECT PART MARK READERS, both by Laurens W. Nunnink, the teachings of which are expressly incorporated herein by reference, provide techniques for improving the transmission of bright field (high angle) and dark field (low angle) illumination. These techniques include the provision of particular geometric arrangements of direct, bright field LEDs and conical and/or flat diffusers that are placed between bright field illuminators and the subject to better spread the bright field light. The above-incorporated HAND HELD SYMBOLOGY READER ILLUMINATION DIFFUSER further teaches the use of par-

US 7,874,487 B2

3

ticular colors for improving the illumination applicable to certain types of surfaces. Often, the choice of bright field, dark field, direct or diffuse light is not intuitive to user for many types of surfaces and/or the particular angles at which the reader is directed toward them. In other words, a surface may appear to be best read using dark field illumination, but in practice, bright field is preferred for picking out needed details, especially at a certain viewing angle. Likewise, with handheld readers, the viewing angle is never quite the same from surface to surface (part-to-part) and some viewing angles be better served by bright field while other may be better served by dark field. The above-referenced patent applications contemplate the application of a plurality of illumination types to achieve the best image for a particular surface and viewing angle.

It has been recognized that handheld readers pose a number of unique concerns. At least some of these concerns are shared in relation to fixed readers. For example, the material from which most light pipes are constructed is acrylic (commonly termed "plexiglass"). Acrylic exhibits a high refractive index (approximately 1.58), which is well suited for internal transmission of light down a light pipe. However, acrylic tends to shatter easily in response to impact. This may limit the life and endurance of a handheld reader (particularly a cordless/wireless model) that is expected to occasionally drop and strike a hard floor, perhaps against the light pipe. While the light pipe could be armored with cushioning and external housings, this undesirably increases production costs, weight, obtrusiveness and may optically obscure the pipe.

Moreover, the light pipes described in the above referenced patents may include a chamfered end to project dark field illumination via internal reflection. Refraction through the polished chamfered end also generates direct bright field illumination. The optical clarity of the light pipe and end tends to create a spotlight effect, in which each individual illumination source (red LEDs, for example) is clearly visible on certain surfaces (see FIG. 7 below). This controverts the typical goal of providing an even spread of illumination.

Also, where a conical diffuser is employed to provide an overall source of direct diffuse illumination, prior art devices are limited in their ability to spread light from a few individual illumination sources (LEDs, for example) throughout the diffuser surface, and then onto the subject as diffuse light. Thus, the diffuse light tends to exhibit a characteristic, localized light spot and dark spot effect. Adding further illumination sources to the diffuse section may be limited both by space and the relative cost of illumination sources, particularly where relatively costly blue-colored LEDs are employed.

Further, prior art readers often include visual indicators located at their back, top or another surface that denote the current status of the reader (for example, power on/off, good read, error, bad read, ready, not-ready, etc.). Various information can be presented to the user via different color lights (red/green, for example) and/or via blinking patterns. However, in a production environment, small, rear-mounted or top-mounted indicators may be overlooked or present a distraction while the user tries to focus on the surface being read. A technique for more-conveniently integrating indicators with the user's main point of interest is highly desirable.

#### SUMMARY OF THE INVENTION

This invention overcomes the disadvantages of the prior art by providing a plurality of novel features that can be applied variously to a reader to improve the illumination performance in both dark field/direct bright field and direct diffuse types of

4

illumination. Further features allow for increased light pipe durability without increasing weight or size and better readability of status indicators by placing such indicators in proximity to the subject and significantly enlarging to overall size of the indicator.

In one embodiment, the light pipe is constructed from durable polycarbonate for increased shock resistance. The chamfered end of the light pipe is textured or frosted to further diffuse refracted light passing through the end so as to present a more even effect. The conical/tapered diffuser within the light pipe is illuminated by a reflector with a white textured surface that reflects a plurality of rearward-directed (opposite the illumination and viewing direction) illumination sources back into the diffuser. The reflector can define a predetermined cross section that directs further light into the forward-most, remote regions of the diffuser to generate a better overall spread of light and alleviate light and dark spotting effects. The textured surface on the chamfered light pipe end can be employed to better project indicator light. The textured surface can alternatively (or in addition) be applied to the exposed portion of the inner wall adjacent to the distal (forward) end of the pipe.

The illumination sources are arranged in a ring at the inner end of the light pipe, and can be multi-colored sources that respond to the controller to project and appropriate color and/or blink in an appropriate pattern to indicate various conditions, such as read success or failure. Typically the controller is adapted to provide these specialized indications between actual image acquisition, so that the image acquisition is properly illuminated. The controller can operate individual portions of the ring so that only corresponding portions of the light pipe perimeter are illuminated in a particular color (quadrants, for example) at a given time. Different quadrants may be simultaneously illuminated in different colors in one example.

In an illustrative embodiment, the light pipe defines a polygonal (for example rectangular) cross section (with the polygon being generally defined as at least four linear or non-linear sides, joined at corners (that may be rounded) to form a (typically) non-equilateral shape. The chamfered edge on each side is at a fixed angle and thus the differing length of the North-South versus East-West sides (in the case of a rectangle), generates two different distances for convergence of dark field rays, which increases depth of field. Stated differently, the polygon (rectangle) includes at least two pairs of opposing sides and the first pair of opposing sides has a length different than the second pair of opposing sides to generate two differing-distance convergence points for dark field rays.

#### BRIEF DESCRIPTION OF THE DRAWINGS

The invention description below refers to the accompanying drawings, of which:

FIG. 1, already described, is a perspective view of a handheld scanning system with integrated illumination according to the prior art;

FIG. 2 is a side cross section of a handheld scanning system that can be employed in connection with the teachings of this invention;

FIG. 3 is a front view of the scanning system of FIG. 2;

FIG. 4 is an exploded view of the illumination assembly and image sensor for the scanning system of FIG. 2;

FIG. 5 is a somewhat schematic side/cross section of the sensor and illuminator assembly for use with the scanning system of FIG. 2 detailing the path taken by various illumination types:



US 7,874,487 B2

5

FIG. 6 is a somewhat schematic side cross section of the light pipe of the illuminator assembly of FIG. 5 more particularly showing the projection of direct bright field illumination;

FIG. 7 is a diagram showing an illumination effect in which individual illumination sources are projected onto a surface through a polished chamfered light pipe end;

FIG. 8 is a fragmentary perspective view of the viewing end of the reader featuring the illumination assembly and having a textured surface on the chamfered light pipe end;

FIG. 9 is a diagram showing an illumination effect achieved on a surface employing a textured chamfered light pipe end in accordance with an embodiment of this invention;

FIG. 10 is a block diagram of the image processor and illumination control circuitry interacting with the sensor, trigger and illumination ring, featuring individual quadrant control and multi-color illumination sources;

FIG. 11 is a fragmentary perspective view of the viewing end of the reader showing the textured chamfered light pipe end illuminated in red as an indicator;

FIG. 12 is a fragmentary perspective view of the viewing end of the reader showing the textured chamfered light pipe end illuminated in green as an indicator;

FIG. 13 is a fragmentary perspective view of the viewing end of the reader showing the textured chamfered light pipe end illuminated in red in predetermined quadrants and green in other predetermined quadrants as an indicator;

FIG. 14 is a schematic side cross section of the, light pipe, diffuser, illumination sources and reflector showing a predetermined reflector geometry so as to increase projection of light along remote regions of the diffuser;

FIG. 15 is a somewhat schematic side cross section of the light pipe of the illuminator assembly detailing the draft angle provided to allow molding of the light pipe and showing an alternative placement of the diffusive surface at the distal end of the light pipe;

FIG. 16 is a schematic diagram of a generalized shape for a rectangular cross section light pipe featuring representations of a North, South, East and West edge;

FIG. 17 is a schematic representation of the convergence of dark field rays from the North and South edges of the light pipe of FIG. 16 showing a first distance thereto;

FIG. 18 is a schematic representation of the convergence of dark field rays from the East and West edges of the light pipe of FIG. 16 showing a first distance thereto; and

FIG. 19 is an exposed perspective view of a light pipe according to an alternate embodiment of this invention defining an elliptical cross section.

#### DETAILED DESCRIPTION OF AN ILLUSTRATIVE EMBODIMENT

FIG. 2 shows a cross sectional side view of an illustrative embodiment of the reader 200 according to the present invention. The imager 212 and an illumination board 214 are positioned on a shock-resistant mounting (not shown) within the housing 206. In this exemplary embodiment, the processor module and related functional electronic components are mounted on a processor board 215. The grip portion 202 and the trigger 204 are functionally cooperative with the housing 206 and components of the processor board 215. The grip portion 206 includes a conveniently placed trigger 204 that can be actuated by a finger of the user to initiate the image acquisition and decoding function. More particularly, pressing the trigger causes all types and colors of illumination (as described further below) to be simultaneously projected onto

6

the subject of interest, and also causes corresponding acquisition of an image by the imager.

With brief reference to the illuminator, the illumination board 214 supports a plurality of LEDs 310 that are red in this embodiment (a variety of colors can be used). The LEDs 310 are directed forwardly, toward the opening of the reader. These LEDs are positioned behind a passive light pipe 244 that internally transmits light from the ring of LEDs 310 to a front end 230. In this embodiment, the front end 230 includes a chamfered surface 232. Various examples of a light pipe for use with a reader or similar application are shown and described in U.S. patent application Ser. No. 10/693,626, entitled LIGHT PIPE ILLUMINATION SYSTEM AND METHOD, by William H. Equitz, et al., the teachings of which are expressly incorporated herein by reference.

Briefly explained, light passes through the extended body of the pipe 244 from the inner end, adjacent to the LEDs 310. The body is formed from a transmissive/transparent substance. As discussed above, one concern for the light pipe is durability and impact resistance. In an embodiment of this invention, the light pipe is constructed from transparent polycarbonate (available under the trade name Makrolon from BASF of Germany, or alternatively Lexan® available from the General Electric Company). This substance can be injection-molded using a liquid resin that is formed into a desired shape as discussed further below. The transmitted light is reflected internally by the angled/chamfered surface 232 of the light pipe 244 to exit at a low angle toward the center optical axis 270. While acrylic displays a superior refractive index (approximately 1.58), it has been recognized that the refractive index of polycarbonate (approximately 1.49) is sufficient to achieve the degree of light transmission and internal reflection employed for dark field illumination in accordance with embodiments of this invention. The inner and/or outer wall surfaces of the light pipe 244 can be coated with opaque paint or another compound to prevent leakage of light into or out of the pipe. In this example, a shield 250 is also provided along the inner surface of the light pipe. One function of the shield 250 is to prevent transmission of diffuse light (described below) in to the light pipe. Another function is to redirect light transmitted from the reflector (see below) back into the diffuser.

In this example, the ring of LEDs 310 acts to produce a red direct bright field effect along with the dark field effect through refraction of some light from the LEDs through the chamfered surface 232. In general, at short reading distances from a surface (<25 mm between the light pipe distal (forward) end 230 and surface), the bright field illumination from the light pipe 230 tends not to interfere with the dark field illumination. The bright field illumination is available, however, for larger reading distances (>25 mm between the end 230 and the surface). This is useful for easy-to-read codes, such as black-and-white printed labels. In alternate embodiments, a separate bright field illuminator can be provided, and as described below. In fact, many available imagers include integral red bright field illuminators. In an alternate embodiment, a separate bright field illuminator can be provided in a discrete color, such as green.

Note that a pair of aiming LEDs 220 (typically emitting green light) are provided. However, these are optional. Such aiming LEDs may be integral with the commercially available image employed herein.

A tether cord 260 provides electrical power to the reader 200, as well as a communication transmission path for the decoded character string of the encoded information, though



US 7,874,487 B2

7

it is contemplated that the reader 200 can be configured with battery power and wireless communication for complete portable flexibility.

With reference also to FIG. 3, a front view of the reader 200 is shown. The distribution and placement of the individual LEDs (or other appropriate light elements) 310 that transmit light to the light pipe 244 is represented by a series of adjacent Xs positioned around the perimeter of the light pipe 244 in line with the distal end 230. The illustrative LED placement creates a generally uniform lighting effect. The placement of these light elements and others used herein is highly variable. In addition, the addressing of light elements can be controlled so that only certain elements are activated at certain times to create the desired overall dark field illumination intensity and/or bias (e.g. lighter on one side than another) to the dark field illumination effect on the subject. This variable-addressing feature is described further below and is discussed in further detail in the above-incorporated U.S. Patent Applications and in other commonly assigned U.S. patent applications referenced therein.

Reference is now also made to the exploded view of FIG. 4, which further details the components of the overall illuminator assembly with respect to the imager 212. As shown, the various illuminator assembly components, described above have been separated to reveal individual structural details. The imager 212 resides at the left side of the view. The illumination board assembly 214 is located ahead of it. Placed in front of the illumination board 214 and LEDs 310 is the proximal (or base) end 410 of the light pipe 244, which receives transmitted light from the LEDs 310, and internally transmits it to the chamfered distal end 230. A tapered (also loosely termed "conical") diffuser 280 (refer also to FIG. 2) is nested within the light pipe 244, with a narrowed proximal opening 420 provided adjacent to the imager 212 and a widened distal opening 422 located at the opposing end. In an illustrative embodiment, this diffuser 280 can be constructed from a thin (1-3 millimeter) polymer material with a frosted/textured interior. As noted above, a thin shield 250 is provided against the interior of the light pipe to block the diffuser's transmitted light from entering the light pipe 244. In this manner, the light emitted from the diffuser does not mix with the light pipe's transmission.

Space may be limited in the region between the shield 250 and the inner surface of the diffuser 280. Moreover, it is contemplated in various embodiments to provide a blue color for the diffuse illumination, employing high-output, blue-colored LEDs, which are more costly than the red or green versions. Thus, use of a smaller number of such LEDs is highly desirable. The fewer individual illumination sources employed, the greater the need to spread the light around the diffuser so as to avoid a light and dark spotting effect on the surface of interest. To accomplish the desired spread of diffuse illumination with a minimal number of individual illumination sources, the light projected by the diffuser is provided by a set of (four) rearward-projecting LEDs 282 mounted on the illumination board 214 on a side opposite the ring of light pipe LEDs 310. These LEDs 282 project rearward into a conical, spherical, parabolic (or other shape) reflector 290 that spreads the reflected light throughout the inner surface of the diffuser 280 so that it exits as a substantially uniform spread of direct, diffuse light onto the surface of interest. As will be described further below, the reflector's shape can be optimized to improve the spread of light along the conical diffuser. In this embodiment, the reflector 290 is constructed from polymer with a white textured surface to further diffuse the light reflected therefrom. This indirect projection of light with a diffusing reflective surface signifi-

8

cantly aids in reducing the number of diffuse illumination LEDs 282 employed to project the diffuse illumination, thereby reducing production costs and power consumption. As noted above, in this embodiment, the diffuse illumination LEDs 282 are high-output blue LEDs. However, the particular colors used for each type of illumination are highly variable. However, it is highly desirable that the diffuse illumination be spaced apart on the spectrum sufficiently from the dark field illumination to allow adequate resolution of the two wavelengths of light

A translucent "conical" filter 292 is provided. The filter 292 is adapted to filter out light with larger wavelengths, thereby allowing smaller wavelength blue light to pass out of the diffuser and onto the surface, but preventing the retransmission of any reflected red light from the surface, which would otherwise tend to become retransmitted as diffuse red light along with the red dark field illumination. The wavelength spread between red light and blue light is sufficient to accomplish this filtering without compromising the performance of either type (dark field/direct bright field versus direct diffuse) of illumination. The filter 292 conforms to the shape of the diffuser's outer (exposed) surface, and can be snapped or adhered onto the diffuser surface using a variety of fastening techniques that should be clear to those of ordinary skill. Note that instead of a separate filter (292), a similar effect can be obtained through the use of a colored diffuser (see FIG. 6 below). The color should be selected so that the diffuser transmits the diffuse light (blue in this embodiment), but does not reflect the dark field light (red in this embodiment) transmitted from the light pipe.

Thus, to summarize, at least two discrete sets of illumination transmitters (LEDs, for example) are provided according to the illustrative embodiment, the direct diffuse transmitters 282 and the dark field transmitters 310. In accordance with the illustrative embodiment, each discrete set of transmitters 282 and 310 generates a corresponding discrete illumination color. For example, direct diffuse illumination can be generated by blue LEDs and dark field (and direct bright field) can be generated by red LEDs. The use of two discrete colors allows each type of illumination to be restricted to its particular application, without mixing, using filtering within the illumination assembly. In this embodiment, each type of illumination creates an image that is received by the imager 212. The imager in this embodiment includes a conventional monochrome sensor that produces a grayscale image from the colored light. Note in alternate embodiments a color sensor can be employed. One such implementation is shown and described in commonly assigned U.S. patent application entitled SYSTEM AND METHOD FOR EMPLOYING COLOR ILLUMINATION AND COLOR FILTRATION IN A SYMBOLOGY READER by Laurens W. Nunnink, and filed on even date herewith, the teachings of which are expressly incorporated herein by reference.

Reference is now made to FIGS. 5 and 6, which describe generally the illumination patterns achieved by the light pipe 244 and diffuser 280 of the illumination assembly. Referring first to FIG. 5, a cross section of an implementation of the diffuser 280 is shown, with light pipe 244 as described generally above, relative to the imager assembly 212 (and associated lens structure 240). Dark field illumination (rays 510) is directed into the light pipe 244 that is internally reflected at the chamfered distal (forward) end 230 to be, thus, directed at the object surface 520 at a low angle. Further information regarding the basic design and implementation of passive light pipes with selectively actuated illumination to provide dark field illumination can be found in the above-incorporated U.S. patent application Ser. No. 10/693,626, entitled

US 7,874,487 B2

9

LIGHT PIPE ILLUMINATION SYSTEM AND METHOD, by William H. Equitz, et al. Direct illumination (rays 532) from blue LEDs 282 is converted into totally diffuse direct illumination by reflection off the reflector 290, and passage into and through the diffuser 280 of this embodiment. The diffuser 280 thereby projects diffuse illumination on the object surface 520 within the field of view, depicted as the region defined by dashed lines 540. In this embodiment the diffuser 280 is, itself, translucent, without a color tint or color-filtering effect. In alternate embodiments, the diffuser can be tinted to generate a desired color and/or act as a filter (using colored or white illumination sources (282)). It should be noted that the diffuser 280 according to this embodiment, and other embodiments described herein, can be constructed and arranged so as to be removably attached to the hand held scanning appliance. In one example, the diffuser can be removed to allow the transmitters 282 to operate as non-diffuse direct bright field illumination. Alternatively, the diffuser can be provided with movable shutters that selectively expose clear (non-frosted/non-diffusing) windows in the overall diffuser. The removability of the diffuser 280 can be achieved by incorporating snap-fit clearances and/or features in the diffuser and light pipe 242 that permit removable assembly (not shown).

In this embodiment direct non-diffuse bright field illumination (see rays 620 in FIG. 6) is provided by refraction of light through the chamfered end 230 of the light pipe 244. As shown particularly in FIG. 6, a portion of the light internally reflected along the pipe 244 exits directly from the chamfered end 230 as relatively high-angle (usually greater than 45 degrees relative to the axis surface 520) bright field light (rays 620). The remaining light is internally reflected by the chamfered end 230 to exit adjacent to the inner corner 630 of the pipe 244 as discussed generally above. Note that the light pipe can be modified in alternate embodiments to include a flattened ring (residing in a plane perpendicular to the axis 270. This would permit additional bright field light to be directly transmitted onto the surface 520. Likewise, a nested light pipe with a flat (unchamfered) ring formed at its distal end can be used in alternate embodiments for direct transmission of bright field light along a waveguide separate from the depicted dark field light pipe 244. This can be useful where illuminators having a discrete color are used for direct bright field light. Alternatively, where optional direct bright field transmitters are employed they can be located so as to project light through clear/transparent portions (not shown) of the diffuser 280.

While not shown in this illustration for simplicity, it can be assumed that a filter (292 above) may be applied over the diffuser to prevent migration of reflected dark field (and bright field) light into the diffuser 280.

As discussed in the above Background of the Invention, illuminator light pipes according to various prior implementations of mark readers include a polished distal end. Referring briefly to FIG. 7, an image 710 acquired of a reflective surface using a light pipe with a polished end is shown. This image 710 clearly depicts delineated spots 720 produced by the individual illumination sources in the illumination ring. These spots lead to a somewhat broken illumination pattern that may effect acquisition of the mark 730.

Referring to FIG. 8, the reader 200 is fitted with an illumination assembly 800 that includes a light pipe 810 according to an embodiment of this invention. The light pipe 810 includes a chamfered end 820 about its forward perimeter having a general size and shape as described above. Notably, the depicted outer surface 830 of the chamfered end 820 is finely frosted or textured. This provides a mild diffusive effect

10

to light exiting as direct bright field illumination (see FIG. 6) and also to internally reflected light exiting as dark field illumination. The resulting diffusion generates the image shown in FIG. 9. Note that the ring of light 920 surrounding the mark 930 is more uniform and the mark, itself, appears better contrasted than the results of the polished-end version shown in FIG. 7.

The frosted or textured surface 830 provided along the chamfered end facilitates a novel and desirable display of reader status according to an embodiment of this invention. Before describing the status display in detail, reference is made to FIG. 10, which schematically describes the basic components of the illumination and image processing system of the reader. The circuit board (215 in FIG. 2) of the reader includes a processor and illumination controller, shown schematically as processor/control block 1010. The processor/control block 1010 can employ conventional image processing and mark-recognition/decoding processes. The processor/control block 1010 receives signals from the trigger (block 1012), which are used to operate the illumination assembly and to obtain image data via the imager (block 1014). The aiming LEDs (block 1016 and see also 220 in FIG. 2) are operated before and during image acquisition under control of the processor 1010. These serve to keep the user aimed at the mark during the acquisition process, particularly where the scan is performed at a standoff distance from the object surface. To this end, it is noted that acquisition of the image according to this embodiment involves a stepping through of a plurality of illumination types (dark field and diffuse) in timed sequence, with associated image acquisition of the mark during each type of illumination. Typically the best image (or a combination of the images) is chosen to decode the data represented by the mark. Before acquisition, and after acquisition, the reader may indicate a variety of status codes, such as ready-to-read, read successful, read unsuccessful, etc. These indicators are described further below.

During the stepping process, the processor 1010 directs the illumination ring (block 1020) to illuminate. It then directs the diffuse illuminator (block 1018) to illuminate. As described in various of the above-incorporated-by-reference patent applications, the ring 1020 can include individual banks of LEDs (or other illumination sources) that, in this example, are formed into quadrants—namely top/north 1022, bottom/south 1024, right/east 1026 and left/west 1028 (as viewed from outside, toward the reader front). These quadrants can be individually addressed by the processor. This allows the output of each quadrant to be varied so as to generate the desired effect on the object. This is particularly useful, where the reader may be disposed at a non-perpendicular angle to the object surface or the surface is non-flat. Various automatic adjustment processes can be included to efficiently cycle through various lighting arrangements among the quadrants to determine the arrangement/profile that achieves the best image. In this embodiment, the individual illumination sources (LEDs 1030) are commercially available multi-color LEDs (red and green in this embodiment, denoted schematically by the split line down the middle of each LED 1030), capable of projecting either of two colors in response to the processor 1010. This can be useful, form an imaging standpoint, where a different color is to be provided for dark field and direct bright field. More significantly, the illumination ring's multicolor capability allows the light pipe (particularly the frosted end 820) to project a highly visible, subject-adjacent indicator light in a plurality of colors.

FIG. 11 details generally the illumination of the light pipe 810 for the purpose of providing the user an indicator. In this example, the four quadrants 1110, 1120, 1130 and 1140 of the

US 7,874,487 B2

11

textured chamfered edge 820 are illuminated red (denoted by the encircled R's) by their appropriate banks of LEDs in the ring. The frosted surface in fact generates a bright, diffuse color strip that enhances viewing of the indicator. This indicator can be illuminated before, during or after image acquisition as a continuous or blinking signal. Blinks can be timed in the manner of Morse code to achieve a desired status message. It should be clear that providing a large, clearly visible indicator light at the distal end of the light pipe (near to the mark—where the user will have his or her-attention focused) affords a highly effective indicator that does not distract the user from the subject at hand and that is visible whether the reader is placed in close proximity to the object surface or at a standoff therefrom. In fact, at standoff distance, the indicator itself projects a colored light onto the surface, further focusing the user's attention on the task at hand.

As shown in FIG. 12, all light-pipe-end quadrants 1110, 1120, 1130, 1140 are illuminated in green (denoted by the encircled G's). This can be a solid (continuously green) or blinking indicator. It can also blink alternatively with red (or another color) according to any predetermined pattern to provide a particular message.

As shown in FIG. 13, the indicator is characterized by two (or more) simultaneous colors displayed by different quadrants (or other sections) of the light pipe edge. In this example, the top quadrant 1110 is red and the left quadrant 1140 is green. The opposed bottom and left quadrants 1120 and 1130, respectively, may also be red and green. This pattern may blink, or alternate (e.g. red and green switch). Likewise, a unique rolling change of colors may occur in which each quadrant, in turn changes to a different color so that the color change appears to migrate around the perimeter. Any observable and desirable shift of colors is contemplated as an indicator according to this invention.

Reference is now made to FIG. 14, which shows a variation of the above-described reflector shape. As discussed above, the length and angle (A) of the conical diffuser 280 (typically less than 45 degrees with respect to the axis 270 in each quadrant) defines a remote, distal region 1410 between the interior wall of the diffuser 280 and the shield 250 that is small in volume and difficult for light from the reflector 1420 to fill adequately. The gap between the inner perimeter of the illumination board 214 and the interior wall of the diffuser further obscures transmission of light into this remote region 1410. Thus, the reflecting surface 1422 of the reflector 1420 of this embodiment includes a plurality of steps 1424, 1426, 1428, 1429 which are designed to direct specific portions of the reflected light (rays 1430) from the LEDs 282 toward the various parts of the diffuser, including the remote regions 1410. Not that, adjacent to the central window 1450 in the reflector (through which the imager views the subject), the plurality of small, angled steps 1429 formed in the cross section are particularly adapted to transmit rays 1430 from the light sources 282 to various points along the remote region 1410 for an optimized spread of light along the entire diffuser surface. The reflector 1420 in this embodiment also includes a textured surface and a white surface color for maximum diffusion. In alternate embodiments, a different surface color and surface finish can be employed. In this manner a more-uniform illumination of the complete diffuser surface is achieved, and the presence of light and dark spotting on the object is minimized.

While a stepped reflector 1420 is shown and described according to an embodiment of this invention, it is expressly contemplated that reflectors having a variety of surface cross-sectional profiles can be employed in alternate embodiments. Such reflectors should be adapted, using optical-focusing

12

techniques, to spread light along the length of a tapered or conical diffuser of a shape generally contemplated herein so as to avoid undesirable spotting on localized regions of the surface of interest.

It is contemplated that a light pipe with a textured or frosted chamfered end according to the various embodiments of this invention can be produced by a variety of techniques including grit blasting or peening of a finished surface, a desirable construction technique entails molding of the light pipe from poured resin. The chamfered end is located near the bottom of the mold and the rearward end (adjacent to the illumination ring) is located at the top of the mold, at which location the finished pipe is ejected from the mold. The bottom of the mold is provided with a frosted or textured pattern so as to form this surface effect on the chamfered end of the finished pipe. Referring to FIG. 15 which shows the cross section of the light pipe 244 the mold is constructed with a slight draft angle that tapers, so that the resulting light pipe 244 defines a pair of inner walls having a draft angle AD therebetween of approximately at least 2 degrees (each side being 1 degree relative to the axis 270). Because the mold includes a frosted/textured surface, the draft angle is set at approximately 2 degrees, rather than the typical 1 degree for a smooth molded part. This 2-degree draft angle better overcomes the possible adhesion effects created between the finished pipe and the textured mold surface. This draft angle is employed where the texture is applied to the chamfered ends 230. Note that the chamfered ends 230 each define therebetween an angle of approximately 70 degrees (each end being approximately 35 degrees relative to the axis 270). It should be clear, however, that the techniques used for forming the light pipe and other components herein can vary within the scope of ordinary skill.

Referring further to FIG. 15, according to an alternate embodiment, the frosted or textured finish can be applied to the inner wall of the light pipe 244 at the end location 1520. This location 1520 is exposed beyond the distal end of the diffuser 280 and shield 250 described above to allow unobstructed passage of dark field light (rays 510). This causes the reflected dark field light to pass through a diffusive structure prior to striking the mark surface. Note that the textured surface can also be applied to the outer side (location 820) in an embodiment of the invention. Alternatively, the textured surface may be selectively applied to only one of the inner location (1520) or outer location (820) as appropriate. It should be noted that, when applying texture to the interior wall at location 1520, the deeded draft angle AD (FIG. 14) would typically be greater than 2 degrees. An appropriate draft angle can be determined by those of skill in the molding plastic parts.

According to the embodiments described above, the general cross sectional perimeter shape of the light pipe is rectangular (taken on a plane through axis 270). For the purposes of this description, the term "rectangular" shall include minor deviations of the sides of the rectangle from a straight-line geometry. In other words, a rectangular shape herein may include, for example, curvilinear arcs as shown and described. In general, the term rectangular shall be defined generally as a set of linear or non-linear sides that intersect at each of four corners (that may be significantly rounded corners) that cause the approximate direction of two adjacent sides to vary by approximately ninety degrees. A highly generalized representation of a rectangular light pipe 1610 is shown in FIG. 16. As described above, the sides 1620, 1622, 1624 and 1626 of the rectangular light pipe 1610 can be defined in terms of North (arrow N), South (arrow S), East (arrow E) and West (arrow W). Likewise, each edge of the distal, chamfered end can be correspondingly represented as



US 7,874,487 B2

13

EN (edge North), ES (edge South), EE (edge East) and EW (edge West). The length LNS between the North edge EN and South edge ES is shorter (in this embodiment) than the length LEW between the East edge EE and West edge EW (LNS < LEW). Note that in alternate embodiments the reverse may be true (LNS > LEW) or is these measurements can be approximately equal.

Referring to FIGS. 17 and 18, the chamfered edge along each side is disposed at the same fixed angle (approximately 55 degrees in this embodiment), generating dark field light rays that converge at point 1710 at an average fixed angle  $\theta$  of approximately 32 degrees (representing half the chamfer angle along with an induced draft angle of 1 degree and further refraction as the light exits the pipe interior wall). Since the distance LNS is less than the distance LEW, the convergence distance of light DNS for the pair of opposing sides EN and ES is less than the convergence distance DEW of light from the pair of opposing sides EE and EW. Thus this arrangement affords a wider depth of field for the reader by providing two differing distance ranges of illumination for the mark. In an embodiment of this invention the approximate length NS is 3 cm, the approximate length EW is 4.5 cm. DNS is approximately 0.92 cm, while DEW is approximately 1.23 cm. Thus a desirable difference of more than 0.31 cm is provided for greater depth of field.

Besides providing a larger depth of field with two projection distances, the above-described rectangular light pipe shape presents several advantages over round light pipes and those of other regular, equilateral shapes. The rectangular shape more closely conforms to the conventional 4.3 horizontal-to-vertical ratio exhibited by commercially available sensors. The rectangular cross section yields a larger dark field range than provided by round pipes. It also allows for a lower-profile reader, in terms of overall height. Moreover, the use of discrete "sides" on the pipe makes it easier to control separate quadrants, as described above.

Note that, while the embodiments described herein generally contemplate somewhat polygonal shapes with adjacent sides connected by corners, it is expressly contemplated that continuously curving joints between "sides" can be provided. As such the terms "sides" and pair of opposing sides should be taken to include ellipses in which the opposing sides spanned by the major axis are greater in length than the opposing sides spanned by the minor axis. In this manner each set of sides generates an average convergence distance for dark field rays that is different, thereby producing the desired enhanced depth of field. To this end, FIG. 19 details an elliptical cross section light pipe 1910 that can be adapted for use with an embodiment of the invention (with appropriate reshaping of the illumination ring and diffuser, where applicable. The distal end of the light pipe 1910 terminates in a chamfered end 1920 having an angle and function as generally described herein. The edge of the chamfered end, in essence defines an opposing pair of North and South sides (1930 and 1932, respectively) and East and West sides (1940 and 1942, respectively), which are separated by distances that differ. In this case the distances are the minor axis MIA and the major axis MAA (respectively) of the ellipse. In this embodiment, the "sides" can be characterized as continuously running into each other with arbitrary boundaries or with "continuously curving corners." A variety of variations on this basic elliptical shape are expressly contemplated. In any case, the sides generate at least two discrete distances of ray convergence for a given fixed chamfer angle.

It should be clear from the above-described embodiments, that a reader having superior illumination and mark-reading capabilities is described herein. This reader alleviates many

14

of the disadvantages encountered with prior art readers, and provided improved object-illumination, status-indication and overall durability.

The foregoing has been a detailed description of illustrative embodiments of the invention. Various modifications and additions can be made without departing from the spirit and scope thereof. For example, any of the various features described herein can be combined with some or all of the other features described herein according to alternate embodiments. Additionally, while a plurality of multicolor LEDs are provided, individual monochromatic LEDs each in a plurality of colors can be arranged adjacent to each other on the illumination ring in alternate embodiments. Likewise, while a ring divided into quadrants is shown, any acceptable division of the overall ring can be provided according to alternate embodiments. Certain parts of the overall ring can be made to work together with other parts according to embodiments hereof. For example, top and right may always work together or top and bottom may always work together. Likewise, additional ring colors, such as yellow can be employed to provide further types of indicators. Multi-colored illumination sources or a plurality of adjacent individual illumination sources (or combinations of individual and multi-colored sources) can be used to generate the desired seat of ring colors. Moreover, while a rectangular light pipe is shown and described, a greater range of depth of field may be obtained by providing a non-equilateral shape having more than four sides joined by corners (for example, an oblique hexagon). This invention contemplates polygonal light pipe cross sections having four or more sides (linear or curvilinear) joined at corners (that may be rounded). Finally, it is expressly contemplated that any of the processes or steps described herein can be implemented as hardware, software, including program instructions executing on a computer, or a combination of hardware and software. Accordingly, this description is meant to be taken only by way of example, and not to otherwise limit the scope of this invention.

What is claimed is

1. An illumination assembly for a mark reader comprising: a light pipe arranged in a surrounding relationship to an interior area through which at least a portion of a mark is detectable having a distal end that is chamfered and includes a diffusive surface texture on the outer surface, wherein light transmitted through the light pipe is internally reflected along the pipe and is internally reflected at the chamfered end through a wall of the light pipe facing the interior area as dark field illumination and is refracted onto the surface at the chamfered end as bright field illumination.
2. The illumination assembly as set forth in claim 1 wherein the light pipe is constructed from polycarbonate.
3. The illumination assembly as set forth in claim 1 further comprising a plurality of illumination sources arranged in a ring in optical communication with the light pipe, the illumination sources being interconnected with a controller that is adapted to project illumination from the illumination sources so as to indicate a predetermined status of the reader in times between instances of illumination of the surface in which an image of the surface is acquired
4. The illumination assembly as set forth in claim 3 wherein the illumination sources comprise multi-colored LEDs that selectively project each of a plurality of colors at pre-determined times to indicate the predetermined status.
5. The illumination assembly as set forth in claim 4 wherein the controller is adapted to project at least two colors on each of adjacent sections of the light pipe simultaneously so as to indicate the predetermined status

US 7,874,487 B2

15

6. The illumination assembly as set forth in claim 4 wherein the controller is adapted to cause the illumination sources to blink so as to indicate the predetermined status.

7. The illumination assembly as set forth in claim 1 further comprising a tapered diffuser located within an interior perimeter of the light pipe, the tapered diffuser being in optical communication with a reflector that receives light from a plurality of rearward-directed illumination sources that project in a direction opposite a direction toward which light from the chamfered end projects toward the surface.

8. The illumination assembly as set forth in claim 7 wherein the reflector includes a surface profile adapted to direct light to a remote region of the diffuser proximate the chamfered end.

9. The illumination assembly as set forth in claim 8 wherein the reflector includes a plurality of steps, at least one of the steps focusing a portion of the light toward the remote region.

10. The illumination assembly as set forth in claim 7 wherein the rearward-directed illumination sources project light through the diffuser onto the surface in a color that differs from a color projected from the chamfered end to illuminate the surface during image acquisition.

11. The illumination assembly as set forth in claim 10 further comprising a filter that allows the color from the diffuser to pass and that prevents the color from the chamfered end from being retransmitted by the diffuser.

12. The illumination assembly as set forth in claim 1 wherein at least one of the interior wall and the chamfered end includes a diffusive surface texture to reduce spotting by discrete illumination sources.

13. An illumination assembly for a mark reader comprising:

a light pipe in optical communication with a ring of illumination sources, the light pipe arranged in a surrounding relationship to an interior area through which at least a portion of a mark is detectable and projecting light in a forward direction from a forward end of the light pipe; and

a tapered diffuser located within an interior perimeter of the light pipe, the tapered diffuser being in optical communication with a reflector that receives light from a plurality of rearward-directed illumination sources that project in a direction opposite the forward direction.

14. The illumination assembly as set forth in claim 13 wherein the reflector includes a surface profile adapted to direct light to a remote region of the diffuser proximate the chamfered end.

15. The illumination assembly as set forth in claim 14 wherein the reflector includes a plurality of steps, at least one of the steps focusing a portion of the light toward the remote region.

16. The illumination assembly as set forth in claim 13 wherein the rearward-directed illumination sources project light through the diffuser onto the surface in a color that differs from a color projected from the chamfered end to illuminate the surface during image acquisition.

17. The illumination assembly as set forth in claim 16 further comprising a filter that allows the color from the diffuser to pass and that prevents the color from the chamfered end from being retransmitted by the diffuser.

18. An illumination assembly for a mark reader comprising:

a light pipe that projects light from a ring of illumination sources onto a surface, the light pipe arranged in a surrounding relationship to a passage through which an imager views the surface having the mark; and

16

wherein the illumination sources are interconnected with a controller that is adapted to project illumination from the illumination sources so as to indicate a predetermined status of the reader in times between instances of illumination of the surface in which an image of the surface is acquired

19. The illumination assembly as set forth in claim 18 wherein the illumination sources comprise multi-colored LEDs that selectively project each of a plurality of colors at predetermined times to indicate the predetermined status.

20. The illumination assembly as set forth in claim 19 wherein the controller is adapted to project at least two colors on each of adjacent sections of the light pipe simultaneously so as to indicate the predetermined status.

21. The illumination assembly as set forth in claim 20 wherein the controller is adapted to cause the illumination sources to blink so as to indicate the predetermined status.

22. The illumination assembly as set forth in claim 18 wherein a distal end of the light pipe includes a chamfered end and at least one of the chamfered end and an interior wall of the light pipe, opposite the chamfered end includes a diffusive surface texture to reduce spoiling by the ring illumination sources.

23. An illumination assembly for a mark reader disposed along an optical viewing axis comprising:

a light pipe defined by at least four adjacent sides including a first opposing pair of sides and a second opposing pair of sides, the light pipe including a chamfered edge at a distal end that directs light from a ring light source at the proximal end onto a surface as dark field; and

wherein a first spacing between the first opposing pair of the sides has a length different than length of a second spacing between the second opposing pair of the sides.

24. The illumination assembly as set forth in claim 23 wherein the light pipe includes a diffuser positioned within an interior defined by the light pipe that projects direct diffuse illumination.

25. The illumination assembly as set forth in claim 23 wherein at least one of the chamfered edge and an interior edge of the light pipe opposite the chamfered edge includes a diffusive surface thereon.

26. The illumination assembly as set forth in claim 25 further comprising an illumination controller adapted to project illumination in at least a first color from the ring so as to provide a first status signal at the chamfered edge.

27. The illumination assembly as set forth in claim 26 wherein the controller is adapted to project illumination in a second color, different than the first color from the ring so as to provide a second status signal at the chamfered edge.

28. The illumination assembly as set forth in claim 23 wherein the first opposing pair of sides and the second opposing pair of sides define collectively an approximate shape of an ellipse.

29. The illumination assembly as set forth in claim 23 wherein the first opposing pair of sides and the second opposing pair of sides collectively define a rectangle having corners between adjacent sides.

30. An illumination assembly for a mark reader comprising:

a light pipe arranged in a surrounding relationship to an interior area through which at least a portion of a mark is detectable, the light pipe having a chamfered distal end that includes a chamfered surface, the chamfered surface having a diffusive surface texture, and

wherein light transmitted through the light pipe is internally reflected along the pipe and is internally reflected at the chamfered distal end through an interior wall of

US 7,874,487 B2

17

the light pipe facing the interior area as dark field illumination and is refracted by the chamfered distal end as bright field illumination.

31. The illumination assembly as set forth in claim 30 wherein the light pipe is constructed from polycarbonate.

32. The illumination assembly as set forth in claim 30 further comprising a plurality of illumination sources arranged in a ring in optical communication with the light pipe, the illumination sources being interconnected with a controller that is adapted to project illumination from the illumination sources so as to indicate a predetermined status of the reader in times between instances of illumination of a surface in which an image of the surface is acquired.

33. The illumination assembly as set forth in claim 32 wherein the illumination sources comprise multi-colored LEDs that selectively project each of a plurality of colors at pre-determined times to indicate the predetermined status.

34. The illumination assembly as set forth in claim 33 wherein the controller is adapted to project at least two colors on each of adjacent sections of the light pipe simultaneously so as to indicate the predetermined status.

35. The illumination assembly as set forth in claim 33 wherein the controller is adapted to cause the illumination sources to blink so as to indicate the predetermined status.

36. The illumination assembly as set forth in claim 30 further comprising a tapered diffuser located within an interior perimeter of the light pipe, the tapered diffuser being in

18

optical communication with a reflector that receives light from a plurality of rearward-directed illumination sources that project in a direction opposite a direction toward which light from the chamfered distal end projects toward a surface.

37. The illumination assembly as set forth in claim 36 wherein the reflector includes a surface profile adapted to direct light to a remote region of the diffuser proximate the chamfered distal end.

38. The illumination assembly as set forth in claim 37 wherein the reflector includes a plurality of steps, at least one of the steps focusing a portion of the light toward the remote region.

39. The illumination assembly as set forth in claim 36 wherein the rearward-directed illumination sources project light through the diffuser onto the surface in a color that differs from a color projected from the chamfered end to illuminate the surface during image acquisition.

40. The illumination assembly as set forth in claim 39 further comprising a filter that allows the color from the diffuser to pass and that prevents the color from the chamfered distal end from being retransmitted by the diffuser.

41. The illumination assembly as set forth in claim 30 wherein at least one of the interior wall and the chamfered distal end includes a diffusive surface texture to reduce spotting by discrete illumination sources.

\* \* \* \* \*

# EXHIBIT B

LETTER FROM DR. ROBERT SHILLMAN TO MR. JOHN O'HIGGINS,  
DATED JUNE 12, 2012

# COGNEX

June 12<sup>th</sup>, 2012

Mr. John O'Higgins  
Chief Executive Officer  
Spectris plc  
Heritage House  
Church Road  
Egham, Surrey, TW20 9QD  
England

Dear John:

It's been quite a while since we've last chatted...and that's a good thing because it means that there have been no problems between Cognex and Microscan. Unfortunately, that lull is about to be interrupted, because I've recently been advised by my engineers and legal team that one or more of Microscan's products appears to infringe one or more of our patents.

Both Cognex and Microscan invest heavily in research and development, resulting in innovation and the creation of intellectual property assets across a wide variety of machine vision technologies. A result of Cognex's extensive R&D is a substantial patent portfolio, with a particular strength in ID handheld readers, and it is in this area where we have discovered a problem. We believe that the technology claimed in our U.S. Patents No. 7,823,789, No. 7,874,487, and No. 8,061,613 (copies are enclosed) is used in certain of your Microscan products, including without limitation, the Microscan Mobile Hawk handheld DPM reader.

As you may recall, Microscan initiated a patent suit against Cognex in May of 2008, and after both parties spent considerable effort and expense, Cognex agreed to settle the matter by entering into a licensing agreement which included a \$2,000,000 payment to Microscan. Based on that experience, your counsel, Roger Stephens, and ours, Todd Keebaugh, recognized that disagreements between us are best worked out through negotiation rather than through litigation, so they included a provision for handling future disputes in Section 6 of the Confidential Settlement Agreement. Per that provision the "next step" is for representatives of both companies to meet and discuss our current grievance and to attempt to work out details of a settlement.

I suggest that that meeting take place at Cognex headquarters in Boston in the near future and that it include members from both of our legal and commercial teams. Please get back to me with your thoughts by June 18<sup>th</sup>.

Sincerely yours,



Robert J. Shillman  
Chairman

Enclosures: U.S. Patents No. 7,823,789, No. 7,874,487, and No. 8,061,613  
CC: T. Keebaugh, R. Willett  
RJS/lc



**CERTIFICATE OF SERVICE**

I hereby certify, pursuant to Title 28 U.S.C. §1746, that on May 7, 2013, I served a true copy of the First Amended Complaint and Jury Trial Demand, by depositing a true copy of said document, properly enclosed in a sealed, post paid envelope, in an official depository of the United States Postal Service, located within the State of New York, County of New York, to be delivered by First Class Mail to:

**Colin J. Garry**  
**Sidley Austin LLP**  
**787 Seventh Avenue**  
**New York, New York 10019**

**Steven J. Hampton**  
**McAndrews, Held & Malloy, LTD**  
**500 West Madison Street, 34<sup>th</sup> Floor**  
**Chicago, Illinois 60661**

I declare under penalty of perjury that the foregoing is true and correct.  
Executed on May 7, 2013.

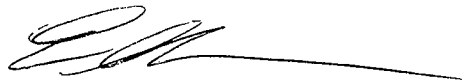

Elvin Ramos