

**IN THE UNITED STATES DISTRICT COURT  
FOR THE EASTERN DISTRICT OF NEW YORK**

Amethyst IP, LLC	§	
	§	
Plaintiff,	§	Civil Action No. _____
	§	
v.	§	<b>JURY TRIAL DEMANDED</b>
	§	
Summer Infant, Inc.	§	
	§	
Defendants.	§	
	§	

**COMPLAINT**

Plaintiff Amethyst IP, LLC (“Amethyst”), for its Complaint against Defendant Summer Infant, Inc. (“Summer Infant”) hereby alleges as follows:

**The Parties**

1. Plaintiff Amethyst is a New York limited liability company with its principal place of business at 1225 Franklin Avenue, Suite 325, Garden City, New York 11530.
2. On information and belief, Summer Infant is a Delaware corporation with a place of business at 1275 Park East Drive, Woonsocket, Rhode Island. On information and belief, Summer Infant’s registered agent for service of process is National Corporate Research, Ltd., 615 S. Dupont Highway, Dover, DE 19901.

**Nature of the Action**

3. This is a civil action for the infringement of United States Patent No. 7,425,901 (“the ’901 patent”) (attached as Exhibit A).

### **Jurisdiction and Venue**

4. This Court has jurisdiction over the subject matter of this action pursuant to 28 U.S.C. §§ 1331 and 1338(a) because this action arises under the patent laws of the United States, including 35 U.S.C. § 271 et seq.

5. This Court has personal jurisdiction over Summer Infant because, among other things, Summer Infant has committed, aided, abetted, contributed to, and/or participated in the commission of patent infringement in this District and elsewhere that led to foreseeable harm and injury to Amethyst.

6. Summer Infant has established minimum contacts within the forum such that the exercise of jurisdiction over Summer Infant will not offend traditional notions of fair play and substantial justice. Moreover, Summer Infant has placed products that, when combined with other products, practice the claimed inventions of the '901 patent into the stream of commerce with the reasonable expectation and/or knowledge that purchasers and users of such products were located within this District. And Summer Infant has sold, advertised, marketed, and distributed products in this District that, when combined with other products, practice the claimed inventions of the '901 patent.

7. Venue is proper in this judicial district pursuant to 28 U.S.C. §§ 1391 and 1400(b).

### **The '901 patent**

8. On September 16, 2008, the '901 patent, titled "Baby Monitoring System With Recording Capability" was duly and legally issued by the United States Patent and Trademark

Office. Amethyst is the assignee of all rights, title, and interest in the '901 patent, and it possesses all rights to sue and recover for any current or past infringement of the '901 patent.

### **Count I**

#### **Infringement of U.S. Patent No. 7,425,901**

9. Paragraphs 1-8 are incorporated by reference as if fully restated herein.

10. Summer Infant has infringed, and continues to infringe, the '901 patent.

11. Summer Infant indirectly infringed, and continues to indirectly infringe, the '901 patent. under 35 U.S.C. § 271, either literally and/or under the doctrine of equivalents, by making, using, offering for sale, selling, and/or importing into the United States camera products as claimed in the '901 patent including at least the Connect Model #28130 ("Camera Products"), along with a display device such as an iPod, iPad or other smartphone or tablet ("Display Product", and together with the Camera Products, the "'901 Infringing Products").

12. On information and belief, Summer Infant's customers directly infringe the '901 patent under 35 U.S.C. § 271, either literally and/or under the doctrine of equivalents by making, using, selling, and/or offering for sale the '901 Infringing Products in the United States. Further, to the extent that Summer Infant itself uses Camera Products with Display Products in the United States, Summer Infant directly infringes the '901 patent under 35 U.S.C. § 271, either literally and/or under the doctrine of equivalents.

13. On information and belief, Summer Infant actively, knowingly and intentionally (from at least the date of the service of this Complaint) induces infringement of the '901 patent by making, using, offering for sale, and selling Camera Products, as well as by contracting with others to use, market, sell, and offer to sell Camera Products. On information and belief,

Summer Infant has also contributed to the infringement by others (e.g., Summer Infant's customers and the users of '901 Infringing Products), and continues to contribute to infringement by others, by selling, offering to sell, or importing Camera Products into the United States, knowing (from at least the date of the service of this Complaint) that those systems constitute a material part of the inventions of '901 Infringing Products, knowing (from at least the date of the service of this Complaint) those systems to be especially made or adapted to infringe the '901 patent, and knowing (from at least the date of the service of this Complaint) that those systems are not staple articles or commodities of commerce suitable for substantial noninfringing use.

14. By way of example, the Summer Infant Easy Install Guide that ships with the Connect Model #28130 instructs customers to install a Summer Infant Monitor app that enables the Connect Model #28130 to be used with a Display Product. A copy of this Easy Install Guide is attached as Exhibit B.

15. Amethyst has been and continues to be damaged by Summer Infant's infringement of the '901 patent.

### **Prayer For Relief**

Wherefore, Plaintiff Amethyst respectfully requests that this Court enter judgment against Summer Infant as follows:

- a) adjudging that Summer Infant has infringed, induced infringement of, and/or contributorily infringed, literally or under the doctrine of equivalents, U.S. Patent No. 7,425,901;
- b) adjudging that Summer Infant's infringement has been willful;
- c) awarding Amethyst the damages to which it is entitled under 35

U.S.C. § 284 for Summer Infant's past infringement and any continuing or future infringement up until the date Summer Infant is finally and permanently enjoined from further infringement, including both compensatory damages and enhanced/treble damages for willful infringement, and ordering a full accounting of same;

- d) finding that this case is exceptional under 35 U.S.C. § 285;
- e) ordering injunctive relief under 35 U.S.C. § 283;
- f) awarding Amethyst pre-judgment and post-judgment interest on its damages; and
- g) awarding Amethyst such other and further relief in law or equity that

the Court deems just and proper.

#### **Demand For Jury Trial**

Amethyst hereby demands a trial by jury on all claims and issues so triable.

DATED: May 29, 2013

Respectfully submitted,

*/s/ Mark I. Koffsky*

Mark I. Koffsky

MARK I. KOFFSKY, P.C.

1225 Franklin Avenue, Suite 325

Garden City, New York 11530

Phone: (516) 279-5595

Fax: (516) 279-5596

[mikecf@koffsky.com](mailto:mikecf@koffsky.com)

*Counsel for Plaintiff*

# Exhibit A



US007425901B2

(12) **United States Patent**  
**Groover**

(10) **Patent No.:** **US 7,425,901 B2**

(45) **Date of Patent:** **Sep. 16, 2008**

(54) **BABY MONITORING SYSTEM WITH RECORDING CAPABILITY**

(76) Inventor: **Jennifer Ann Groover**, 1 Windbrook Dr., Springfield, PA (US) 19064

(\* ) Notice: Subject to any disclaimer, the term of this patent is extended or adjusted under 35 U.S.C. 154(b) by 270 days.

(21) Appl. No.: **11/360,310**

(22) Filed: **Feb. 23, 2006**

(65) **Prior Publication Data**

US 2006/0197671 A1 Sep. 7, 2006

**Related U.S. Application Data**

(60) Provisional application No. 60/655,992, filed on Feb. 24, 2005.

(51) **Int. Cl.**  
**G08B 23/00** (2006.01)

(52) **U.S. Cl.** ..... **340/573.1**; 340/539.15

(58) **Field of Classification Search** ..... 340/573.1, 340/539.15

See application file for complete search history.

(56) **References Cited**

**U.S. PATENT DOCUMENTS**

6,043,747 A 3/2000 Altenhofen ..... 340/573.1

6,593,851 B1 *	7/2003	Bornstein .....	340/539.15
6,766,145 B2	7/2004	Fitzgerald et al. ....	455/67.11
6,975,832 B2 *	12/2005	Adams et al. ....	434/317
2004/0199391 A1 *	10/2004	Yoon et al. ....	704/275
2004/0264938 A1 *	12/2004	Felder .....	386/96

\* cited by examiner

*Primary Examiner*—Thomas J Mullen, Jr.

(74) *Attorney, Agent, or Firm*—Gregory S. Bernabec; Saul Ewing LLP

(57) **ABSTRACT**

A baby monitoring system including a baby unit for receiving audio signals, and a parent unit for reproducing an audio signal received at the baby unit. At least one of the baby and parent units includes audio signal recording capability, e.g. using a digital voice recorder. Preferably, at least one of the units includes a port capable of outputting data representing a stored audio signal, such that the data can be stored in a memory of a PC or other device. Thus, a baby's sounds/words may be monitored and recorded/stored in the memory of the baby monitoring system, downloaded to a separate device with long term storage capability, and the memory of the baby monitoring system may be reused to record new sounds, causing deletion of previously recorded sounds from the baby monitoring system's memory while permitting long term retention of a record of such sounds in the separate device.

**21 Claims, 3 Drawing Sheets**

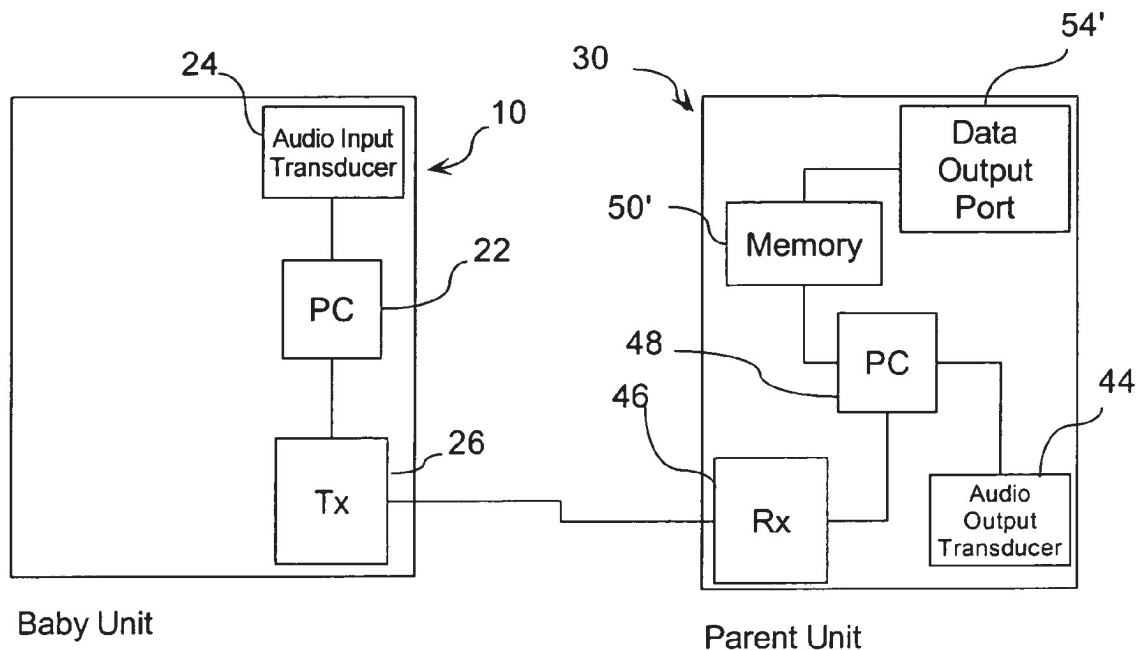

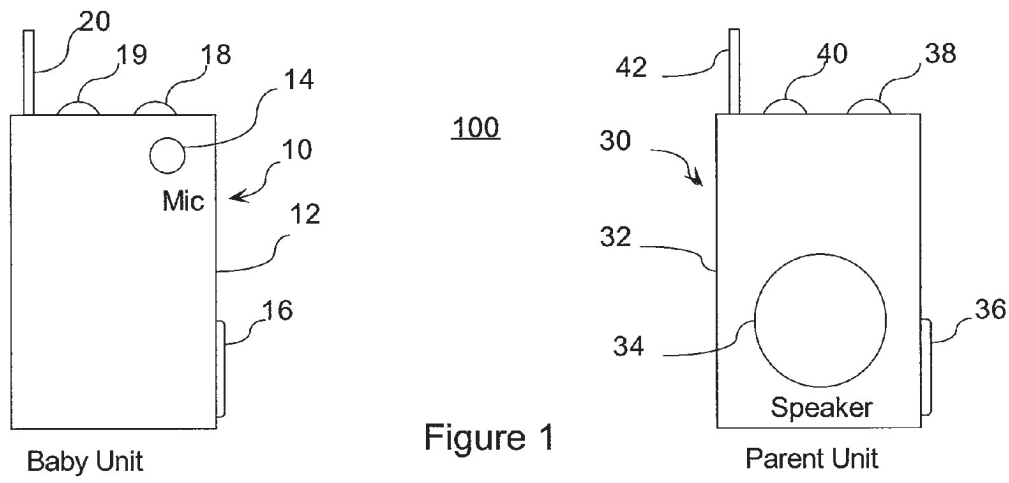

Figure 1

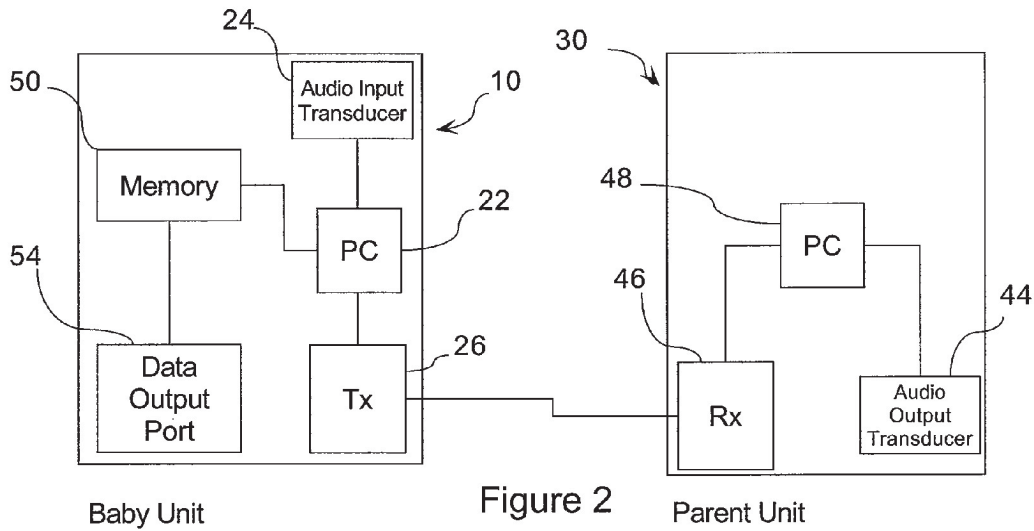

Figure 2

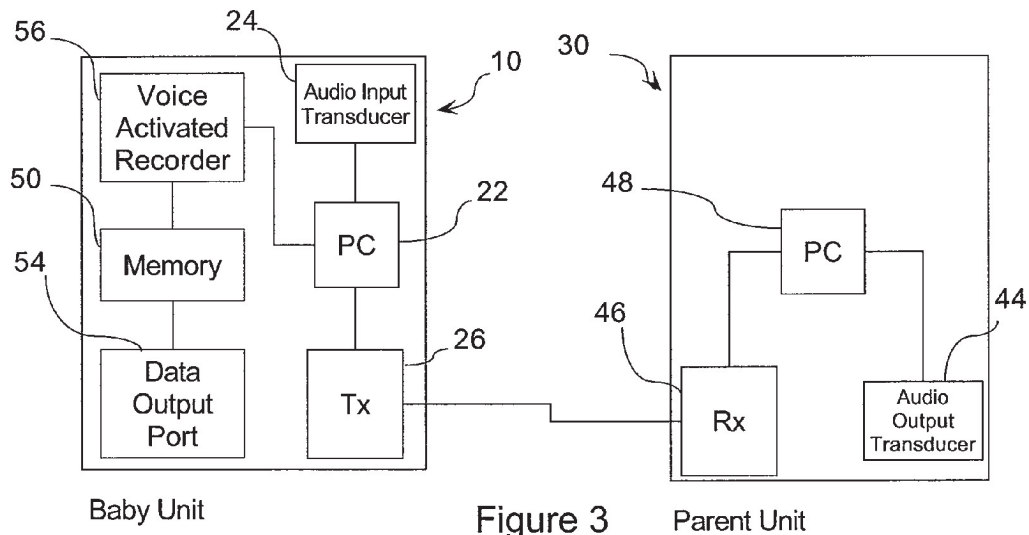

Figure 3



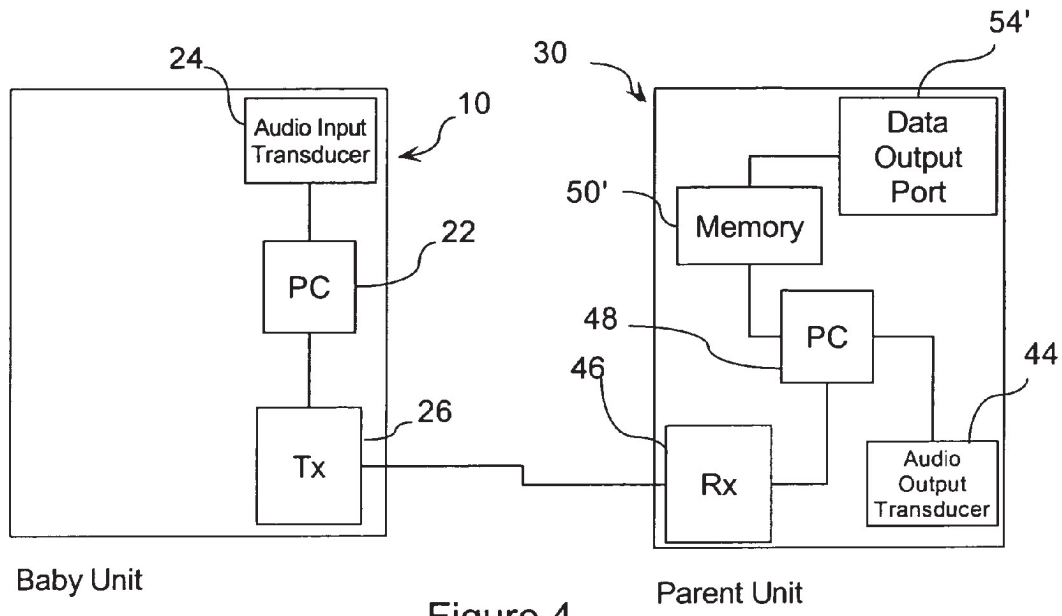

Figure 4

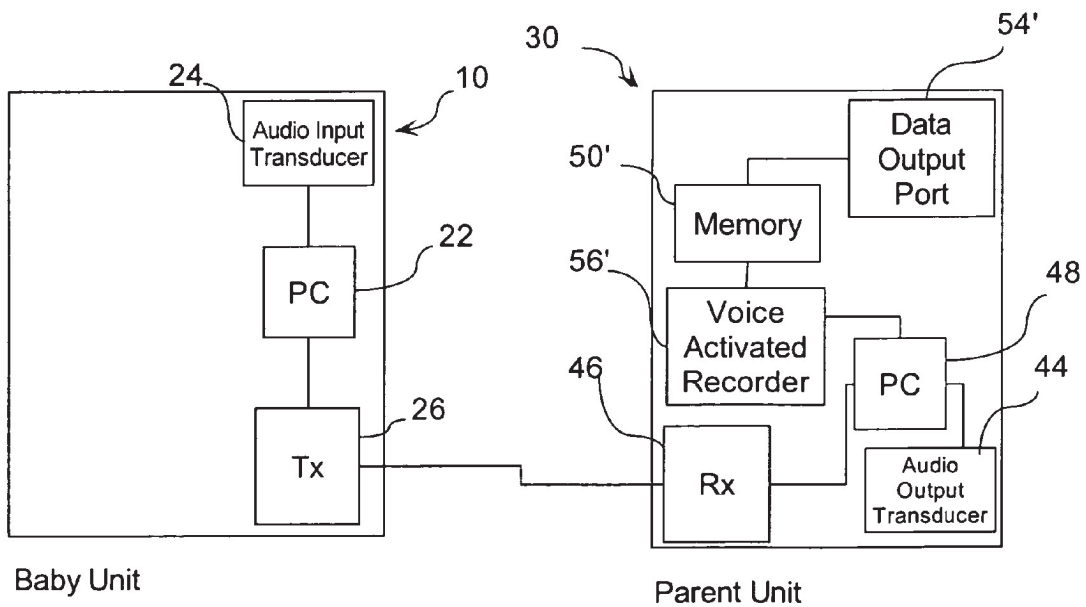

Figure 5

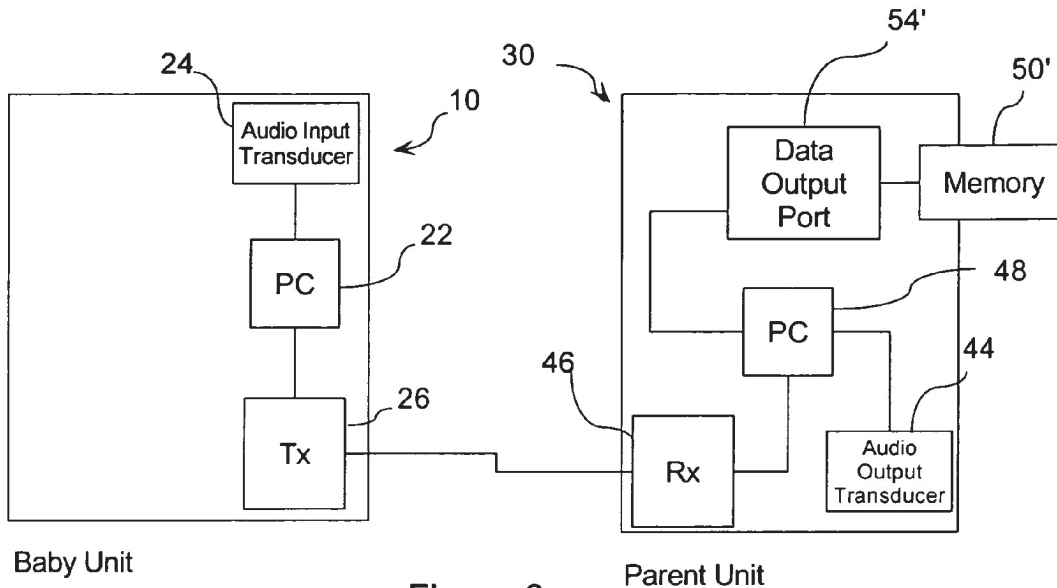

Figure 6

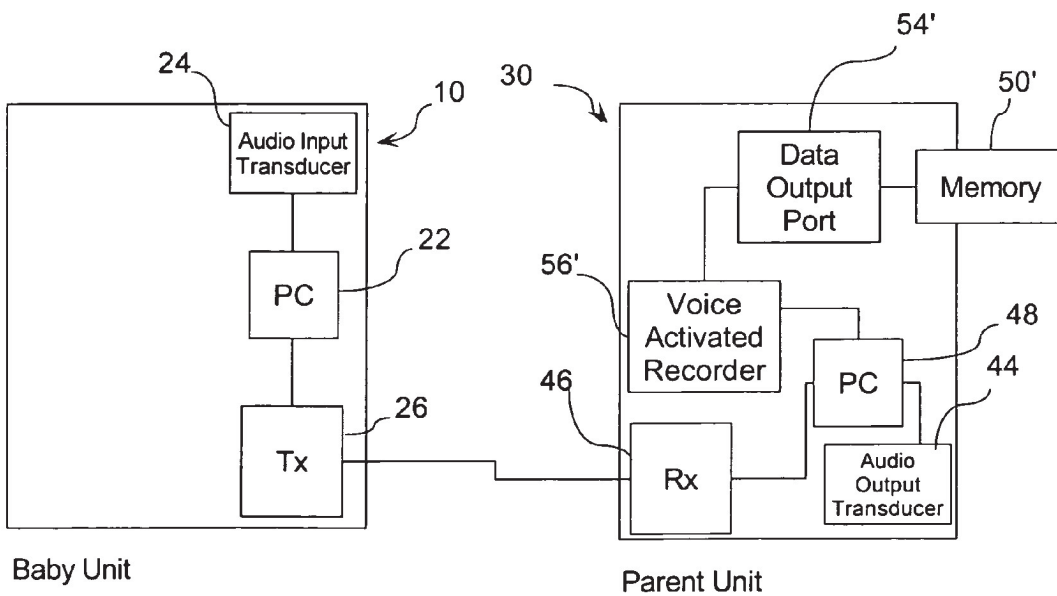

Figure 7

1

## BABY MONITORING SYSTEM WITH RECORDING CAPABILITY

### CROSS-REFERENCE TO RELATED APPLICATION

This application claims the benefit of U.S. Provisional Patent Application No. 60/655,992, filed Feb. 24, 2005, the entire disclosure of which is hereby incorporated herein by reference.

### FIELD OF THE INVENTION

The present invention relates generally to baby monitors and more particularly to a baby monitoring system of a type generally used by parents to monitor from a remote location a baby in a baby's room.

### BACKGROUND OF THE INVENTION

The present invention relates generally to baby monitors and more particularly to a baby monitoring system that includes a parent unit and a baby unit that have a one-way or two-way radio frequency communications link established therebetween. Baby monitor systems of this type, such as the Fisher-Price® Sweet Dreams Monitor™ manufactured and/or sold by Mattel, Inc. of El Segundo, Calif., are well known in the art.

Some baby monitors include certain limited recording functionality. For example, U.S. Pat. No. 6,043,747 to Altenhofen discloses a baby monitor system that includes a message storage mechanism. More specifically, the parent unit, which is carried by the parent, includes a microphone that allows a care giver to record and store in a digital message memory at the parent unit a soothing message for playback to the baby via the baby unit, which remains in the baby's room. In response to activation of a play switch on the parent unit, the message is reproduced by a speaker on the baby unit. The entire disclosure of U.S. Pat. No. 6,043,747 is hereby incorporated herein by reference.

U.S. Pat. No. 6,766,145 discloses a child monitor system that is similar to conventional nursery room baby monitors in that includes a local unit (carried by the parent) and a remote unit (located in the child's room) that are capable of wirelessly communicating with each other. Each unit has the capability of receiving and outputting acoustic audio signals as well as the capability of transmitting and receiving the signals to and from the units. In one embodiment, the local unit includes a memory in which input signals from either unit may be stored prior to being output. For example, the memory may be implemented by a common digital recording integrated circuit such as a commercially available Winbond Electronics Corp. voice recorder with SRAM. This allows a user to save and later playback sounds made by infant near the remote unit. Accordingly, the system receives, at the remote (baby) unit, sounds made by an infant and transmits the sounds to the local (parent) unit. The system then stores the sounds in the memory of the local (parent) unit. In order to output these recorded sounds, the system retrieves the infant sounds from the memory and outputs the sounds at a speaker of the local unit. In operation, the end-user pushes a record button to record and the system records sounds over sounds previously recorded and stored in memory. The entire disclosure of U.S. Pat. No. 6,766,145 is hereby incorporated herein by reference.

### SUMMARY

Conventional baby monitors seek to monitor a baby's well being, etc. The inventor hereof has determined that baby

2

monitors are inadequate for recording and storing a baby's speech/sounds, and for creating a record of such speech/sounds that may be maintained in long term storage and subsequently accessed therefrom, e.g. for archival and/or nostalgic purposes. It has been determined that it would be desirable to combine such recording and storage functionality with conventional and/or existing baby monitoring functionality.

The present invention provides such a baby monitoring system. In particular, at least one of the baby unit and parent unit of the baby monitoring system includes a data output port capable of outputting data representing an audio signal stored in a memory of the units to and external long-term data storage device. Preferably the data output port is capable of outputting a data signal in digital or other form in a conventional format for plug-and-play interconnection with PC compatible electronic devices, such as a memory key/jump drive (collectively "memory key") with a USB connector.

In this manner, new sounds may be recorded in memory of the baby monitoring system, causing old sounds to be deleted from the memory, and yet a permanent/long-term record of the sounds may be retained in an external memory for later reference and/or reproduction, e.g. to retain a record of your child's first words that will allow for audio reproduction of those words using conventional PC hardware and/or software, or the like.

### BRIEF DESCRIPTION OF THE DRAWINGS

The present invention will now be described by way of example with reference to the following drawings in which:

FIG. 1 is a diagram of an exemplary baby monitoring system including an exemplary baby unit and an exemplary parent unit in accordance with the present invention;

FIG. 2 is a schematic diagram showing the principal logical components of an exemplary embodiment of the baby and parent units of FIG. 1;

FIG. 3 is a schematic diagram showing the principal logical components of an alternative exemplary embodiment of baby and parent units of FIG. 1;

FIG. 4 is a schematic diagram showing the principal logical components of another alternative exemplary embodiment of baby and parent units of FIG. 1;

FIG. 5 is a schematic diagram showing the principal logical components of yet another alternative exemplary embodiment of baby and parent units of FIG. 1;

FIG. 6 is a schematic diagram showing the principal logical components of yet another alternative exemplary embodiment of baby and parent units of FIG. 1; and

FIG. 7 is a schematic diagram showing the principal logical components of yet another alternative exemplary embodiment of baby and parent units of FIG. 1.

### DETAILED DESCRIPTION

The present invention allows for recording and storing a baby's speech/sounds, and for creating a record of such speech/sounds that may be maintained in long term storage and subsequently accessed therefrom, e.g. for archival and/or nostalgic purposes.

FIG. 1 shows an exemplary embodiment of a baby monitoring system 100 in accordance with the present invention. As shown in FIG. 1, the system 100 includes a baby unit 10 for placement in a baby's room to monitor the baby's speech/sounds, and a parent unit 30 for use by parents to remotely monitor the baby's speech/sounds by reproducing at its speaker, sounds picked up by a microphone of the baby unit 10.

3

In this embodiment, the parent unit **30** includes a molded plastic parent unit housing **32** which includes a speaker cover **34**, and provides for receipt of a screw fastened battery compartment cover **36**, an on/off switch **38**; a volume control switch **40**, and a parent unit antenna **42**. With reference to FIGS. **2, 3, 4** and **5**, the parent unit **30** also includes processing circuitry **48**, an audio output transducer (speaker) **44**, and a wireless receiver **46**. Optionally, the parent unit's housing may include a conventional belt clip for attaching the parent unit to a user's belt.

Further, as shown in FIG. **1**, in this exemplary embodiment, the baby unit **10** includes a molded plastic baby unit housing **12** which includes a microphone cover **14**, and provides for receipt of a battery and/or an AC power adapter (not shown), an optional on/off switch **18**, and a baby unit antenna **20**. With reference to FIGS. **2, 3, 4** and **5**, the baby unit **10** also includes processing circuitry **22**, an audio input transducer (such as a condenser microphone) **24**, and a wireless transmitter **26**.

These components are well known in the art and function largely in a conventional manner, as described in greater detail in U.S. Pat. No. 6,766,145, the entire disclosure of which is incorporated herein by reference. By way of summary, the audio input transducer **24** of the baby unit **18** converts an incident acoustic input into a first input signal. Acoustic input can include speech, crying, breathing, and other sounds etc., from an infant or child (collectively, "baby"). The processing circuitry **22** of the baby unit converts the input signals into an output signal that is received by the wireless transmitter **26** for wireless transmission to the wireless receiver **46** of the parent unit **30**.

Generally, the present invention operates as a baby monitor as follows. The audio input transducer **24** of the baby unit **10** receives a first acoustic input (baby speech/sounds) and converts it to a first input signal that is passed through to the transmitter **26** of the baby unit **10** via processing circuitry **22** (which may be incorporated into transmitter **26**). The transmitter **26** of the baby unit **10** transmits this signal to the receiver **46** of the parent unit **30** by wireless transmission. The parent unit's receiver **46** passes the received signal on to its processing circuitry **48**. The processing circuitry **48** of the parent unit converts the first output signal into a second output signal, which the output transducer (speaker) **44** converts into an audio (acoustic) output (reproduced speech/sounds).

Hardware for providing such functions is well known in the art and described in greater detail in U.S. Pat. No. 6,766,145. By way of summary, it is noted that power to the electronic components of the parent unit **30** is supplied by a main power supply which, in this exemplary embodiment, consists of a 9V battery housed in a battery compartment in housing **32**. The baby unit **10** includes may include a similar power supply but preferably includes as an alternative an AC power adapter (not shown) for connection to a power supply. The audio input transducer **24** of baby unit **10** is implemented as an omnidirectional condenser microphone mounted on the housing **12**. The transmitter and receiver circuitry used in the baby and parent units may be any suitable standard circuitry, as will be appreciated by those of ordinary skill in the art. By way of example, one suitable implementation is a 49 MHz system available from Excel Engineering, Ltd of Japan. Many other systems (including, for example, 900 MHz systems) are available from various suppliers. Similarly, any suitable system may be used for the conversion circuitry in the baby and parent units, by which the inputs from either baby unit microphone or parent unit receiver are converted to output signals for the baby unit transmitter or parent unit audio output transducer, respectively.

4

In accordance with the present invention, either the baby unit, or the parent unit, or both are provided with a memory, recording capability for storing in the memory recorded data for reproducing audio signals, and data output capability for transferring the recorded data from the memory to an external data storage device, such as external data memory. For example, a data output port is provided for connection of an external data memory device, such as a personal computer, which may include a writable CD or DVD drive, a computers hard disk drive, etc., or a USB or other port for connection of a stand alone hard drive, floppy disk drive, CD or DVD drive, tape drive, flash memory drive/key, or any other device capable of storing the data, and retaining the data apart from any memory of the baby unit or parent unit. In this manner, the memory of the baby unit or parent unit may be erased, and additional sounds may be recorded in the memory, while the parent may retain a record of the previously recorded sounds on the PC, etc.

The memory **50** may be implemented in any of a number of ways that will be apparent to one of ordinary skill in the art. By way of example, a commercially available digital recording integrated circuit such as a Winbond Electronics Corp. voice recorder with SRAM memory may be employed for this purpose.

Similarly, the Data Output Port **54** may be implemented in any of a number of ways that will be apparent to one of ordinary skill in the art, provided that the Data Output Port **54** is capable of transmitting data to a conventional electronic data storage device such as a PC, memory key, hard disk drive, I/O board of a PC, floppy disk drive, CD drive, DVD drive, etc. By way of example, a conventional USB port or cable may be employed for this purpose.

In the exemplary embodiment of FIG. **2**, the baby unit **10** includes the memory **50** and the Data Output Port **54**. The memory **50** is in communication with the audio input transducer **24** in order to store an audio signal received therefrom. In this exemplary embodiment the connection is made via processing circuitry **22** which processes the input audio signal and prepares it for storage in the memory and/or for output via the Data Output Port in a format compatible with commercially available computer software for reproducing audio signals, such as a \*.mpg, \*.wav, \*.avi, \*.wma, \*.snd, \*.au, \*.mid, \*.asf, or the like.

In this embodiment, in which the memory is in the baby unit, recording begins when the baby unit is switched on via the on/off switch **18**. Alternatively, recording to the memory begins when an on/off recording button **19** on the baby unit is pressed. Recording to the memory stops when the memory is full, or when a predetermined amount of time has elapsed, or when the baby unit is switched off, or when the on/off recording switch **19** is pressed. In operation, the system records sounds over sounds previously recorded and stored in the memory. However, before recording over such sounds, such sounds may be copied from the memory via the data output port. By way of example, this may occur automatically upon connection of such a device, or the memory may be configured to act like a memory key, such that conventional PC software may be used to retrieve data from the memory and copy it to another storage device, such as the PC's hard disk drive. Accordingly, this configuration allows the user to record and later download for storage on an external storage device sounds made by a baby near the baby unit.

In the exemplary embodiment of FIG. **3**, the baby unit **10** similarly includes the processing circuitry **22**, memory **50**, the Data Output Port **54**. However, in this embodiment, the baby unit **10** also includes a Voice Activated Recorder (VAR) **56**, which may be implemented by conventional circuitry or otherwise as will be appreciated by those skilled in the art. The VAR **56** senses when the baby is making sounds by monitoring the signal received from the audio input trans-

5

ducer 24, and initiating recording to the memory 50 only when it senses that such sounds are being made, and to stop/pause recording when it senses that such sounds are not being made. For example, the VAR 56 may include circuitry for determining when the audio signal includes more than mere background noise. Such VAR circuitry is commercially available and well known in the art. Accordingly, in this embodiment, the on/off recording button 19 is used to simply turn on or off the VAR 56. Other operation is similar to that described above.

FIGS. 4 and 5 are somewhat similar to FIGS. 2 and 3 respectively, except that the memory 50', Data Output Port 54' and optional VAR 56' are provided in the parent unit 30. These components function in a manner corresponding to the manners described above. As discussed above, recording to the memory and/or turning on of the VAR 56' may be initiated by turning the parent unit 30 on via its on/off switch 38. Alternatively, and additional on/off recording button may be provided on the parent unit 30 similar to button 19 of the baby unit 10, for use as described above. It should be noted that in the embodiment of FIG. 5, the VAR 56' monitors signals received from the parent units receiver 46 and/or processing circuitry 48 to determine whether the baby is making sounds near the baby unit 10.

FIG. 6 shows an alternative embodiment of a parent unit or baby unit that includes a similar Data Output Port 54, but includes memory that is physically removable from the unit. For example, the memory may be provided in the form of a conventional memory key/flash drive/jump drive having a USB connector. In this manner, the memory may be physically removed from the unit and connected to a conventional PC or the like.

FIG. 7 shows an alternative embodiment similar to that of FIG. 6, but also including a VAR.

It should be understood that the embodiments shown are exemplary only and that other embodiments are within the scope of the present invention. By way of example, the memory, Data Output Port, and/or VAR need not be provided in the same unit. Instead some of these components may be provided in one of the baby unit and parent unit, and the other(s) of these components may be provided in the other of the baby unit and parent unit. For example, the VAR and memory may be provided in the baby unit, and the Data Output Port may be provided in the parent unit, data from the memory in the baby unit being transmitted from the baby unit 10 to the parent unit 30 and its Data Output Port via the transmitter and receiver of the units. In other embodiments, both of the baby unit and the parent unit may be provided with a VAR, memory and/or Data Output Port.

With general reference to FIGS. 1-7, the parent unit and baby unit collectively include a conventional radio frequency transmitter and receiver circuit, a conventional analog to digital microphone amplification circuit, a conventional digital to analog converter and a conventional speaker drive circuit. The radio frequency transmitter and receiver circuits of the parent unit and baby unit are complementarily tuned to establish a two way radio frequency communications link between the parent unit 30 and baby unit 10.

In use, baby unit 10 is used to monitor the sounds within the baby's environment and transmit those sounds for reproduction on parent unit speaker 44 of parent unit 30. Sounds from within the baby's environment are automatically recorded and stored as data for subsequent retrieval in the memory of one of the baby unit 10 and parent unit 30. The stored data is subsequently selectively downloadable from one of the baby unit 10 and parent unit 30 to a conventional electronic data storage device such as a memory key/jump drive, personal computer's hard drive, CD drive, or the like for long-term storage. In this manner, new sounds may be recorded in the memory, causing old sounds to be deleted from the memory,

6

and yet a permanent/long-term record of the sounds may be retained for later reference and/or reproduction, e.g. to retain a record of your child's first words that will allow for audio reproduction of those words using conventional PC hardware and/or software, or the like.

It is noted that the embodiment of the baby monitor system described herein in detail for exemplary purposes is of course subject to many different variations in structure, design, application and methodology. Because many varying and different embodiments may be made within the scope of the inventive concept(s) herein taught, and because many modifications may be made in the embodiment herein detailed in accordance with the descriptive requirements of the law, it is to be understood that the details herein are to be interpreted as illustrative and not in a limiting sense.

What is claimed is:

1. A baby monitoring system comprising:

a first unit comprising

a first audio input transducer for converting a first acoustic input into a first input signal,

first processing circuitry for creating a first output signal from said first input signal, and

a transmitter for transmitting said first output signal; and

a second unit comprising

a second unit housing,

a receiver for receiving said first output signal from said transmitter, said receiver being disposed within said second unit housing,

second processing circuitry for creating a second output signal from said first output signal, said second processing circuitry being disposed within said second unit housing,

an output transducer for converting output signals to acoustic output, said output transducer being mounted to said second unit housing,

a memory configured to store in digital data form said first output signal, said memory being disposed within said second unit housing, and

a data output port mounted on said second unit housing and operatively connected to said memory for communicating digital data stored in said memory.

2. The baby monitoring system of claim 1, further comprising:

voice activated recording circuitry operatively connected to said memory to selectively store data in said memory.

3. The baby monitoring system of claim 1, wherein said data output port of said second unit comprises a USB connector.

4. The baby monitoring system of claim 1, wherein one of said first and second processing circuitry processes one of said first input signal and said first output signal into a data file format compatible with commercially available computer software for reproducing audio signals.

5. The baby monitoring system of claim 4, wherein the data file format is selected from a group consisting of \*.mpg, \*.wav, \*.avi, \*.wma, \*.snd, \*.au, \*.mid and \*.asf data file formats.

6. A baby monitoring system comprising:

a first unit comprising

a first audio input transducer for converting a first acoustic input into a first input signal,

first processing circuitry for creating a first output signal from said first input signal, and

a transmitter for transmitting said first output signal; and

a second unit comprising

a second unit housing,

a receiver for receiving said first output signal from said transmitter, said receiver being disposed within said second unit housing,

7

second processing circuitry for creating a second output signal from said first output signal, said processing circuitry being disposed within said second unit housing,

an output transducer for converting output signals to acoustic output, said output transducer being mounted to said second unit housing, and

a data output port mounted on said second unit housing for communicating digital data; and

a memory key comprising

a memory key housing,

a data port mounted on said memory key housing and configured to operatively mate with said data output port of said second unit, and

a memory configured to store in digital data form said second output signal received via said data output port, said memory being disposed within said memory key housing, said memory key being selectively connectable to and removable from said data output port of said second unit.

7. The baby monitoring system of claim 6, further comprising:

voice activated recording circuitry operatively connected to said data output port to selectively communicate data via said data output port.

8. The baby monitoring system of claim 6, wherein said data port of said memory key competes a USB connector.

9. The baby monitoring system of claim 6, wherein one of said first and second processing circuitry processes one of said first input signal and said first output signal into a data file format compatible with commercially available computer software for reproducing audio signals.

10. The baby monitoring system of claim 9, wherein the data file format is selected from a group consisting of \*.mpg, \*.wav, \*.avi, \*.wma, \*.snd, \*.au, \*.mid and \*.asf data file forms.

11. A baby monitoring system comprising:

a first unit comprising

a first unit housing,

a first audio input transducer for converting a first acoustic input into a first input signal,

first processing circuitry for creating a first output signal from said first input signal,

a transmitter for transmitting said first output signal,

a memory configured to store in digital data form said first output signal, said memory being disposed within said first unit housing, and

a data output port mounted on said first unit housing and operatively connected to said memory for communicating digital data stored in said memory; and

a second unit comprising

a receiver for receiving said first output signal from said transmitter,

second processing circuitry for creating a second output signal from said first output signal, and

an output transducer for converting output signals to acoustic output.

12. The baby monitoring system of claim 11, further comprising:

voice activated recording circuitry operatively connected to said memory to selectively store data in said memory.

13. The baby monitoring system of claim 11, wherein said data output port of said first unit comprises a USB connector.

14. The baby monitoring system of claim 11, wherein one of said first and second processing circuitry processes one of said first input signal and said first output signal into a data file format compatible with commercially available computer software for reproducing audio signals.

8

15. The baby monitoring system of claim 14, wherein the data file format is selected from a group consisting of \*.mpg, \*.wav, \*.avi, \*.wma, \*.snd, \*.au, \*.mid and \*.asf data file formats.

16. A baby monitoring system comprising:

a first unit comprising

a first unit housing,

a first audio input transducer for converting a first acoustic input into a first input signal,

first processing circuitry for creating a first output signal from said first input signal,

a transmitter for transmitting said first output signal, and a data output port mounted on said first unit housing for communicating digital data; and

a second unit comprising

a receiver for receiving said first output signal from said transmitter,

second processing circuitry for creating a second output signal from said first output signal, and

an output transducer for converting output signals to acoustic output; and

a memory key comprising

a memory key housing,

a data port mounted on said memory key housing and configured to operatively mate with said data output port of said first unit, and

a memory configured to store in digital data form said second output signal received via said data output port, said memory being disposed within said memory key housing, said memory key being selectively connectable to and removable from said data output port of said first unit.

17. The baby monitoring system of claim 16, further comprising:

voice activated recording circuitry operatively connected to said data output port to selectively communicate data via said data output port.

18. The baby monitoring system of claim 16, wherein said data port of said memory key comprises a USB connector.

19. The baby monitoring system of claim 16, wherein one of said first and second processing circuitry processes one of said first input signal and said first output signal into a data file format compatible with commercially available computer software for reproducing audio signals.

20. The baby monitoring system of claim 19, wherein the data file format is selected from a group consisting of \*.mpg, \*.wav, \*.avi, \*.wma, \*.snd, \*.au, \*.mid and \*.asf data file formats.

21. A baby monitoring system comprising:

a first unit comprising

a first audio input transducer for converting a first acoustic input into a signal, and

a transmitter for transmitting said signal; and

a second unit comprising

a second unit housing,

a receiver for receiving said signal from said transmitter, said receiver being disposed within said second unit housing,

an output transducer for converting signals to acoustic output, said output transducer being mounted to said second unit housing,

a memory configured to store said signal in digital data form, said memory being disposed within said second unit housing, and

a data output port mounted on said second unit housing and operatively connected to said memory for communicating digital data stored in said memory.

\* \* \* \* \*

# Exhibit B

# CONNECT INTERNET BABY

28130

## Easy Install Guide

Start Here

### 1 Components



(camera)

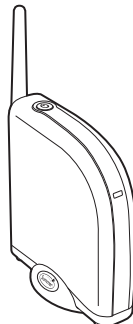

(gateway)

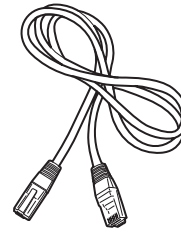

(ethernet cable)

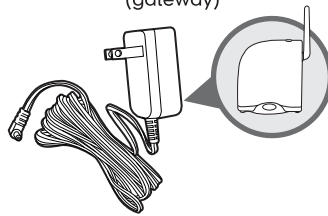
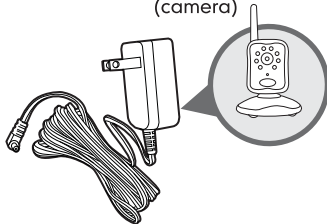

#### hardware:



x1



x1

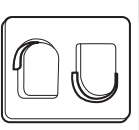

x6

#### ⚠ WARNING:

**STRANGULATION HAZARD -** Children have STRANGLED in cords. Keep this cord out of reach of children (more than 3 feet (0.9 m) away from the crib). Use enclosed Security Clips to help secure cord away from baby's reach. Never use extension cords with AC Adapters. Only use the AC Adapters provided.



### 2 Set Up Camera (Wall Mount)

2A

Determine a location to mount the CAMERA to the wall that will provide the best view of your baby in the crib. NEVER place camera or cords within **3 feet** of the crib.

#### IMPORTANT



mount at least 3ft. from crib

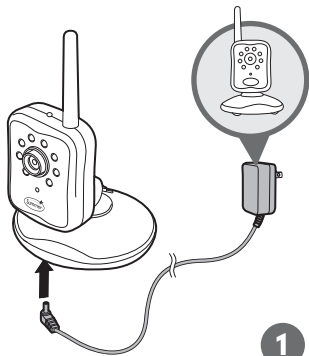

1



2

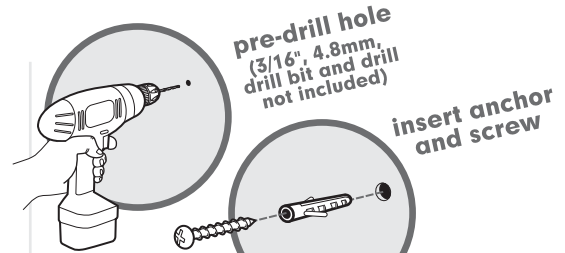

pre-drill hole (3/16", 4.8mm, drill bit and drill not included)

insert anchor and screw

3

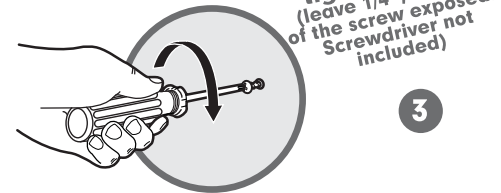

tighten screw (leave 1/4", 6.2mm, of the screw exposed. Screwdriver not included)

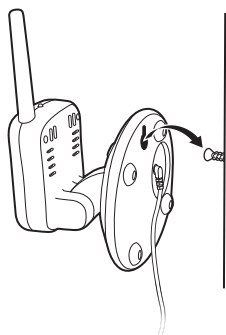

4

#### IMPORTANT

at least 3ft.



5

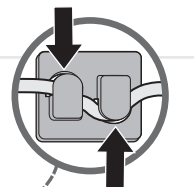

Secure the cord to the wall using the **6 Security Clips** included to keep cord away from baby's reach.

plug in

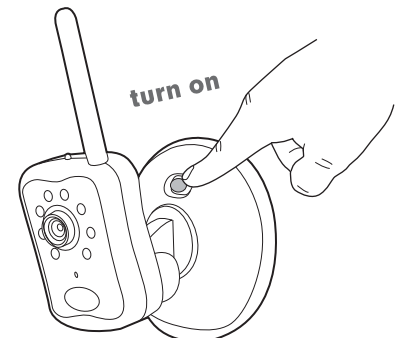

turn on

6



# Using Your Connect Internet Baby Camera Set Online

**System Requirements:** At the installation location of your gateway, you need a broadband Internet connection (cable/DSL) with recommended upload speed of 300 kbps and a wireless router and/or a cable/DSL modem with an available ethernet/LAN port to properly access and view your camera. You must have a required browser version Internet Explorer 7.0 or higher, Safari 4.0 or higher, Mozilla Firefox 3.0 or higher or Google Chrome. Make sure you have the latest version of Adobe Flash Player which you can download at <http://www.adobe.com/support/flashplayer/downloads.html>.

## 1 Getting Started Online

Visit [internetviewable.summerinfant.com/activate](http://internetviewable.summerinfant.com/activate)



1

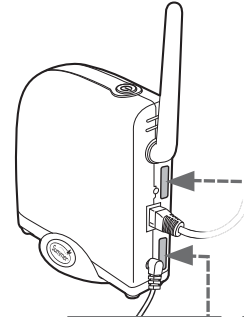

Serial No.:  
1230000000000000

Activation Code:  
ABC000000000

2

Locate your product's Serial Number and Activation code located on the back of your gateway. You will use this to activate your account.

## 2 Signing Up & Activating



1

Email Address

Confirm Email

Choose a password

Confirm password

Choose a security question:  
What was your childhood nickname?

Answer to your security question:



Fill in Fields.



2

Serial Num: ABC000000000000 Act. Code: 0000000000

Serial Number

Activation Code

Child's Name

Yes, I agree to the [terms of service](#).



Fill in Fields.



3

### COMPLETE ACTIVATION AND BEGIN LIVE VIEWING OF YOUR CHILD!

A confirmation email will be sent to you in a few moments. Please follow the link listed in the email to access live video of your child.