

**UNITED STATES DISTRICT COURT
WESTERN DISTRICT OF NEW YORK**

AMERICAN TACTICAL IMPORTS, INC.,

Plaintiff,

vs.

TENNESSEE ARMS COMPANY LLC,

Defendant.

**COMPLAINT AND
JURY DEMAND**

Civil Action No.: 14-6575

Plaintiff, American Tactical Imports, Inc. (“ATI”), by its attorneys, Woods Oviatt Gilman LLP, for its complaint against the defendant, Tennessee Arms Company LLC (“TAC”), alleges as follows:

PRELIMINARY STATEMENT

1. This is an action brought by ATI against TAC for infringement of United States Patent No. 8,789,305 (“the ‘305 Patent”), in violation of the United States Patent Laws, 35 U.S.C. §§1 *et seq.* ATI also asserts claims for trademark infringement under state and federal law and a common law claim for unfair competition.

JURISDICTION AND VENUE

2. This court has jurisdiction over the subject matter of the complaint by virtue of 15 U.S.C. §§1114, 1125(a), 35 U.S.C. §§271 *et seq.* and 28 U.S.C. §§1331 and 1338(a). The court has jurisdiction over the state law claims by virtue of 28 U.S.C. §§1338(b) and 1367, as well as CPLR 302.

3. Venue is proper pursuant to 28 U.S.C. §1391 and 1400(b).

4. Upon information and belief, TAC markets, sells and contracts to sell its goods in

New York State and, thereby, transacts business within the state of New York.

THE PARTIES

5. Plaintiff, ATI, is, and at all times hereinafter mentioned was, a corporation authorized to do business under the laws of the State of New York and, until December of 2013, its principal office and place of business was located at 100 Airpark Drive, Rochester, New York.

6. Upon information and belief, Defendant TAC, is, and at all times hereinafter mentioned was, a corporation organized and existing under the laws of Tennessee, with its principle office and place of business at 1050 South Main Avenue, Dyersburg, Tennessee.

U.S. PATENT NO. 8,789,305

7. On July 29, 2014, the '305 Patent entitled "Hybrid Lower Receiver for a Rifle" was issued by the United States Patent and Trademark Office (a copy of the '305 Patent is attached hereto as **Exhibit "1"**).

8. ATI is the lawful owner of, and owns all right, title and interest to, the '305 Patent and has the sole and exclusive right to exclude others from making, using, selling and offering for sale any and all products covered by the '305 Patent.

9. The '305 Patent relates to a combination metal/polymer lower receiver for use in a rifle whereby the lower receiver attaches to a buttstock including a receiver extension and an upper receiver having a bolt carrier group. The lower receiver is adapted to be detachably attached to a buttstock, including a receiver extension having a recoil spring and buffer assembly, and an upper receiver having a bolt, bolt carrier and charging handle. The lower receiver is comprised of a polymeric lower receiver housing with a polymeric upwardly extending lobe configured to receive the receiver extension. The polymeric lower receiver housing is further

adapted to detachably engage with the mounting features on the upper receiver. A metal insert is rigidly secured within the polymeric upwardly extending lobe wherein the metal insert is adapted to detachably engage the receiver extension.

10. The modular construction of the rifle into which the invention is incorporated enables quick and easy field-stripping (disassembly of the rifle for cleaning to ensure proper firing). The invention combines the weight reduction and cost savings afforded by polymeric materials with the mechanical and structural strength and durability of the metal insert.

11. The '305 Patent includes one independent claim and two dependent claims.

Independent claim one of the '305 Patent reads:

A combination metal/polymer lower receiver for use in a rifle, the lower receiver being adapted to be detachable attached to a buttstock including a receiver extension having a recoil spring and buffer assembly, and an upper receiver having a bolt, bolt carrier and charging handle, the lower receiver comprising:

(a) A polymeric lower receiver housing have an integral polymeric upwardly extending lobe configured to receive the receiver extension therethrough, the polymeric lower receiver housing adapted to detachably engage with mounting features on the upper receiver to attach said lower receiver to said upper receiver; and

(b) A metal insert rigidly secured within the polymeric upwardly extending lobe wherein the metal insert is adapted to detachably engage the receiver extension.

(Exhibit "1" 6:57-7:5).

TAC'S PRODUCT

12. Upon information and belief, TAC manufactures, uses, sells and/or offers to sell in the United States products which include the "Tennessee Arms Hybrid Polymer Lower Receiver" (the "Accused Product"). According to TAC, the Accused Product is "a polymer lower receiver with imbedded metal inserts" which "combines the stability of polymer with the

reliability of metal reinforcement in the buffer tube . . . “

13. Upon information and belief, TAC manufactures, uses, sells and offers to sell in the United States the accused product, either as a stand-alone product or as a component of a “parts kit” which it makes available to the consuming public (copies of screenshots from TAC’s website reflecting TAC’s marketing of the Accused Product are attached hereto as **Exhibit “2”**).

TAC’S INFRINGEMENT OF THE ‘305 PATENT

14. Upon information and belief, the Accused Product is a combination metal/polymer lower receiver for use in a rifle wherein the lower receiver is adapted to be detachably attached to a buttstock including a receiver extension having a recoil spring and buffer assembly and an upper receiver having a bolt, bolt carrier and charging handle.

15. Upon information and belief, the polymeric lower receiving housing in the Accused Product has an integral polymeric upwardly extending lobe configured to receive the receiver extension and the polymeric lower receiving housing is adapted to detachably engage with the mounting features on the upper receiver in order to attach the lower receiver to the upper receiver.

16. Upon information and belief, in the Accused Product, a metal insert is rigidly secured within the polymeric upwardly extending lobe wherein the metal insert is adapted to detachably engage the receiver extension.

17. Upon information and belief, the Accused Product infringes Claim 1 of the ‘305 Patent.

18. Upon information and belief, TAC knew or should have known about the ‘305 Patent as it (1) has been a matter of public record since July 29, 2014, (2) addresses the need for a lower receiver assembly which capitalizes upon the weight and cost savings afforded by

polymeric materials while enjoying the mechanical and structural strength afforded by metal, a need which TAC has also attempted to address, (3) would have been identified as part of the due diligence process leading up to the filing of the patent application purportedly filed by TAC as noted on its website, (4) was brought to the attention of TAC in an exchange of communications in November of 2013 when representatives of ATI advised representatives of TAC that ATI had a pending patent application for the invention, and (5) should have been identified by TAC as part of its ongoing efforts to research competitors in the marketplace.

19. TAC was put on notice of the '305 Patent as set forth above or will have been put on notice of the '305 Patent as of the date of service of the complaint in this action.

20. Furthermore, TAC was put on notice of the '305 Patent and its infringement thereof or will be out on notice no later than the written communication is made to TAC advising it (1) of the issuance of the '305 Patent and (2) the filing of this action.

**AS AND FOR A FIRST CAUSE OF ACTION,
PLAINTIFF ALLEGES AS FOLLOWS:**

Direct Infringement (35 U.S.C. §271(a))

21. ATI repeats and re-alleges the allegations of paragraphs "1" through "20" as if more fully set forth herein.

22. In violation of 35 U.S.C. §271, TAC has directly infringed, either literally or under the Doctrine of Equivalents, and continues to directly infringe, claim one of the '305 Patent, by making, using, selling and/or offering for sale within the United States a hybrid lower receiver for a rifle as more particularly described above.

23. TAC continues to make, use, sell and/or offer to sell the Accused Product which infringes the '305 Patent.

24. ATI has been, and continues to be, damaged as a result of TAC's infringement within the Western District of New York and elsewhere.

25. Said acts of infringement are willful and deliberate. At a minimum, TAC has acted recklessly and in disregard of ATI's rights since TAC first became aware of the '305 Patent, as set forth above.

26. As a result of the foregoing, ATI has been damaged in an amount to be determined by the trier of fact in accordance with 35 U.S.C. §284.

**AS AND FOR A SECOND CAUSE OF ACTION,
PLAINTIFF ALLEGES AS FOLLOWS:**

Trademark Infringement (15 U.S.C. §§1114(1), 1125(a) and 1125(c))

27. ATI repeats and re-alleges paragraphs "1" through "26" as if more fully set forth herein.

28. On April 21, 2008, ATI filed an Intent-to-Use trademark application pursuant to section 1(b) of the Trademark Act, which application was assigned Serial No. 77453340, with the United States Patent & Trademark Office ("USPTO") for the mark American Tactical (and design) as depicted below ("the AT Mark"):



The '340 application was allowed and published for Opposition on July 26, 2011. With no third party having filed an Opposition against the '340 application, the application subsequently

registered September 18, 2012 as U.S. TM Reg. No. 4,210,270). The goods covered by this Trademark include firearms and various firearm components.

29. Since at least 2011, ATI has used the AT Mark in commerce in connection with its business of selling firearms and related equipment. Over the years, ATI has earned a reputation for quality goods and services, personal attention to its customers and integrity in its business dealings and, as such, has earned the respect of both its customers and competitors.

30. In the years that its business has been in operation, ATI has advertised and otherwise promoted its products throughout the United States and, as a result, has developed significant name recognition and goodwill and has attained a solid reputation within the marketplace.

31. ATI owns and operates a website to advertise its goods and services at the URL: <http://www.americantactical.us>. ATI's Trademark and its website were created at great expense to ATI over many years and it owns the exclusive rights and recognition to the goodwill associated therewith.

32. ATI's advertising and other promotional efforts, including the securing of the AT Mark and the operation of its website, have been undertaken at great expense for the purpose of developing and perpetuating name recognition and goodwill among existing and prospective customers, vendors and other constituencies.

33. These advertising and promotional efforts have been effective and ATI's Trademarks, including the AT Mark, are all associated with ATI and no other individuals or entities.

34. Based upon prior communications between representatives of ATI and TAC, TAC knows of ATI's Trademarks and is aware that ATI uses the AT Mark in commerce.

35. In conjunction with its business, TAC has been using a mark (“the TA Mark”) which is confusingly similar to the AT Mark as set forth below:



(See Exhibit “2”).

36. TAC maintains a website at the URL <http://tnarmsco.com> and also at www.tennesseearmscompany.com. Upon information and belief, TAC was well aware of ATI’s existence, its trademarks (including the AT Mark), and its products at the time TAC first began to use its confusingly similar mark.

37. As can be seen from a comparison of the AT Mark with the Defendant’s AT Mark, they are confusingly similar. Both employ a capital A and a capital T superimposed over one another within a geometrical form, except ATI uses a diamond shape and TAC uses a circle.

38. Upon information and belief, TAC purposely selected and continues to use the TA Mark which is substantially similar to the AT Mark, evidencing TAC’s bad faith and attempt to ride the coattails and profit from ATI’s extensive trademark brand recognition, good faith and reputation and commercial success in the firearms business.

39. TAC is now using the TA Mark to directly compete with the Plaintiff and its use of a confusingly similar mark has, or threatens to, cause mistake or confusion in the eyes of the public and deceive the public as to the affiliation, connection or association of TAC with ATI, or to confuse the public as to the origin, sponsorship or approval of TAC's products and services, thereby infringing and deluding the AT Mark and violating its intellectual property rights.

40. As a result of the foregoing, TAC has violated 15 U.S.C. §§1114(l), 1125(a) and 1125(c) and is liable to ATI for any damage ATI has sustained and will sustain in the event TAC is allowed to continue its infringing and unlawful activity.

**AS AND FOR A THIRD CAUSE OF ACTION,
PLAINTIFF ALLEGES AS FOLLOWS:**

State Law Claims

41. ATI repeats and re-alleges the allegations of paragraphs "1" through "40" as if more fully set forth herein.

42. TAC's conduct as referenced above, violates general principles of law and equity, constitutes trade name infringement, unfair competition and injury to business reputation under New York General Business Law §§360-K, 360-L and 360-N and has caused, and continues to cause, ATI irreparable injury.

43. ATI has no adequate remedy at law.

44. As a result of the foregoing, ATI is entitled to a permanent injunction, restraining and enjoining TAC, and all others acting on its behalf or in its stead, from using its mark and any other marks which are confusingly similar or marks which are dilutive to, or otherwise violate, ATI's Trademark.

**AS AND FOR A FOURTH CAUSE OF ACTION,
PLAINTIFF ALLEGES AS FOLLOWS:**

Common Law Unfair Competition

45. ATI repeats and re-alleges the allegations of paragraphs “1” through “44” as if more fully set forth herein.

46. TAC’s conduct as alleged above constitutes common law trade name infringement and unfair competition arising under the laws of the State of New York.

47. If TAC is permitted to continue using its mark and any other marks which are confusingly similar to ATI’s Trademark, ATI will be irreparably harmed.

48. ATI has no adequate remedy at law.

49. As a result of the foregoing, ATI is entitled to a permanent injunction, restraining and enjoining TAC, and all others acting on its behalf or in its stead, from using its mark and any other marks which are confusingly similar or marks which are dilutive to, or otherwise violate, ATI’s Trademark.

**AS AND FOR A FIFTH CAUSE OF ACTION,
PLAINTIFF ALLEGES AS FOLLOWS:**

Declaratory Judgment

50. ATI repeats and re-alleges the allegations of paragraphs “1” through “49” as if more fully set forth herein.

51. As a result of the foregoing, ATI is entitled to a judgment (1) that TAC has infringed, and continues to infringe claim number one of the ‘305 Patent and (2) further declaring the respective rights and responsibilities of the parties.

52. As a result of the foregoing, ATI is entitled to a judgment (1) declaring that it has superior rights to its trademark and/or any similar mark; and (2) declaring that TAC is the junior user of the mark referenced in paragraph 28 above which is confusingly similar to, or dilutive to, ATI's Trademark; and (3) further declaring the respective rights and responsibilities of the parties.

TRIAL BY JURY DEMANDED

Plaintiff demands a trial by jury on all issues so triable.

WHEREFORE, Plaintiff, American Tactical Imports, Inc., requests judgment as follows:

A. Declaring that the Defendant, Tennessee Arms Company, LLC, has infringed United States Patent Number 8,789,305;

B. Granting a permanent injunction, restraining and enjoining Defendant, Tennessee Arms Company, LLC, its officers, directors, agents, servants, employees, and all other in privity, concert or participation with them or, on their behalf, from further acts of patent infringement, including the manufacture, use, sale and/or offering for sale infringing products;

C. Declaring that United States federally registered Trademark 4,210,270 owned by Plaintiff, American Tactical Imports, Inc., has been infringed by Defendant, Tennessee Arms Company, LLC;

D. Granting a permanent injunction, restraining and enjoining Defendant, Tennessee Arms Company, LLC, its officers, directors, agents, servants, employees and all others in privity, concert or participation with them or, on their behalf, from further acts of trademark infringement;

E. Granting an accounting for damages adequate to compensate Plaintiff, American Tactical Imports, Inc. for infringement of the '305 Patent, such damages to be trebled to the extent allowed by law due to the willful and deliberate character of the infringement;

F. Awarding the Plaintiff, American Tactical Imports, Inc., all compensatory damages suffered as a result of the Defendant's, Tennessee Arms Company, LLC, actions;

G. Awarding to Plaintiff its attorneys' fees and costs;

H. Further declaring the rights and responsibilities of the parties; and

I. Awarding the Plaintiff such other and further relief as to this Court may seem just and proper.

DATED: October 3, 2014
Rochester, New York

WOODS OVIATT GILMAN LLP

By: 

Donald W. O'Brien, Jr., Esq.
Katherine H. McGuire, Esq.
Attorneys for Plaintiff
700 Crossroads Building
2 State Street
Rochester, New York 14614
585.987.2800

EXHIBIT 1



US008789305B1

(12) **United States Patent**
DiChario

(10) **Patent No.:** US 8,789,305 B1
(45) **Date of Patent:** Jul. 29, 2014

(54) **HYBRID LOWER RECEIVER FOR A RIFLE**

(56) **References Cited**

(71) Applicant: **American Tactical Imports, Inc.**,
Rochester, NY (US)

U.S. PATENT DOCUMENTS

(72) Inventor: **Anthony DiChario**, Pittsford, NY (US)

7,428,795 B2 *	9/2008	Herring	42/75.01
8,141,287 B2 *	3/2012	Dubois	42/75.02
8,342,075 B2 *	1/2013	Gomez	89/191.01
8,615,917 B2 *	12/2013	Higgins	42/96

(73) Assignee: **American Tactical Imports, Inc.**,
Rochester, NY (US)

* cited by examiner

(*) Notice: Subject to any disclaimer, the term of this patent is extended or adjusted under 35 U.S.C. 154(b) by 0 days.

Primary Examiner — Reginald Tillman, Jr.

(74) Attorney, Agent, or Firm — Woods Oviatt Gilman LLP;
Katherine H. McGuire, Esq.

(21) Appl. No.: 13/927,152

(57) **ABSTRACT**

(22) Filed: Jun. 26, 2013

A combination metal/polymer lower receiver for use in a rifle. The lower receiver attaches to a buttstock including a receiver extension, and an upper receiver having a bolt carrier group. The lower receiver comprises a polymeric lower receiver housing having an integral polymeric upwardly extending lobe. The polymeric receiver housing engages with mounting features on the upper receiver to attach the lower receiver to the upper receiver. A metal insert is secured within the polymeric upwardly extending lobe and engages the receiver extension. The metal insert includes insert side walls incorporated within the polymer sidewalls of the lower receiver housing such that the sidewalls are adapted to receive a take-down pin to secure the upper receiver to the lower receiver. The metal insert can further include an elevated plate for displaying component identifiers.

(51) **Int. Cl.**
F41A 11/02 (2006.01)
F41A 3/66 (2006.01)

(52) **U.S. Cl.**
CPC F41A 3/66 (2013.01)
USPC 42/75.03

(58) **Field of Classification Search**
CPC F41A 21/482
USPC 42/16, 75.01-75.03
See application file for complete search history.

3 Claims, 7 Drawing Sheets

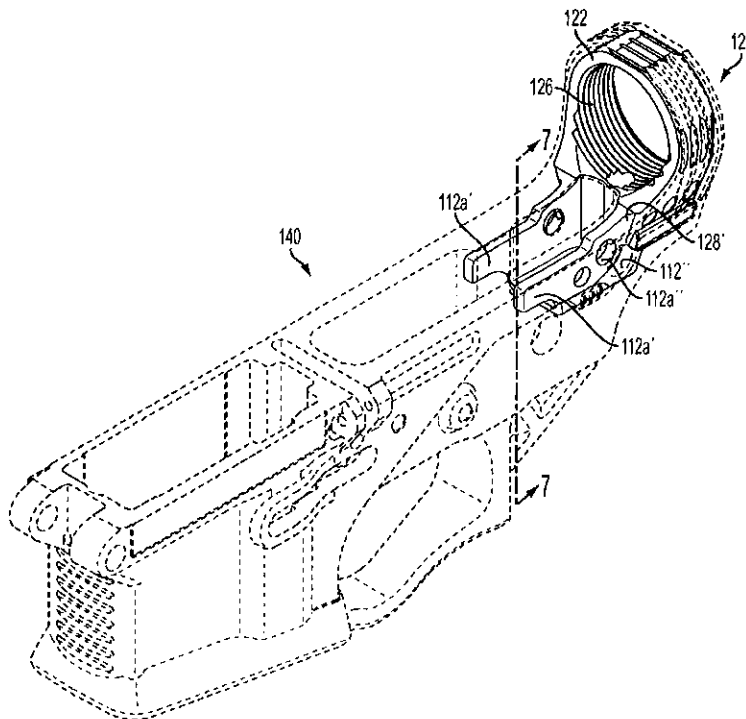

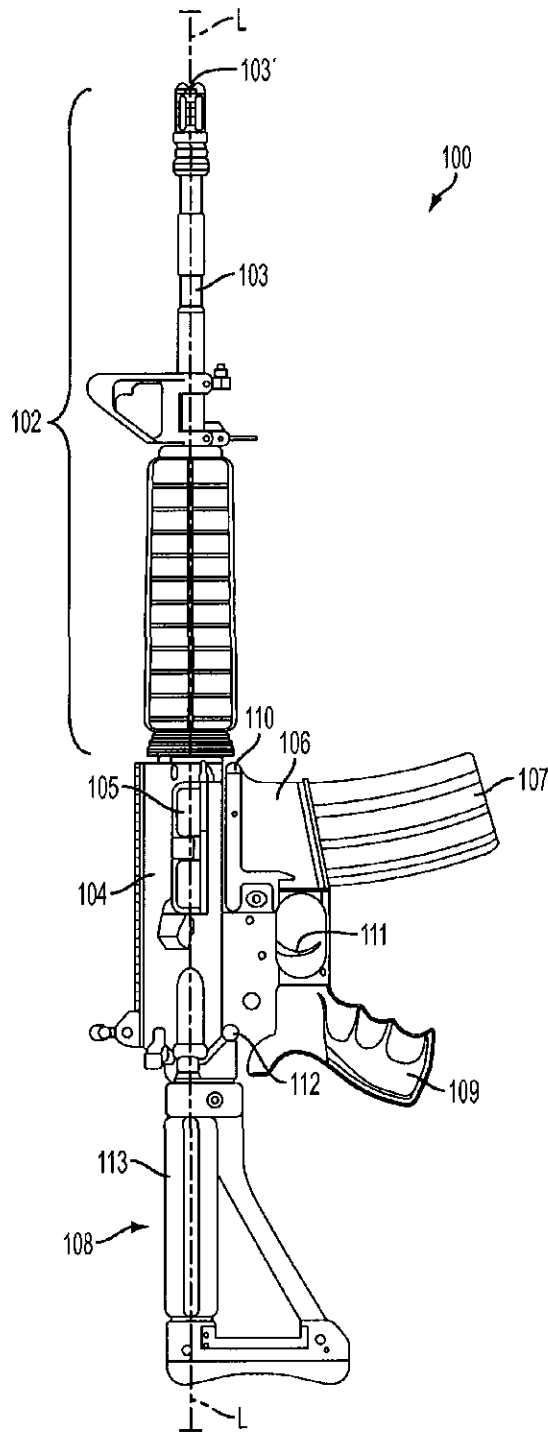
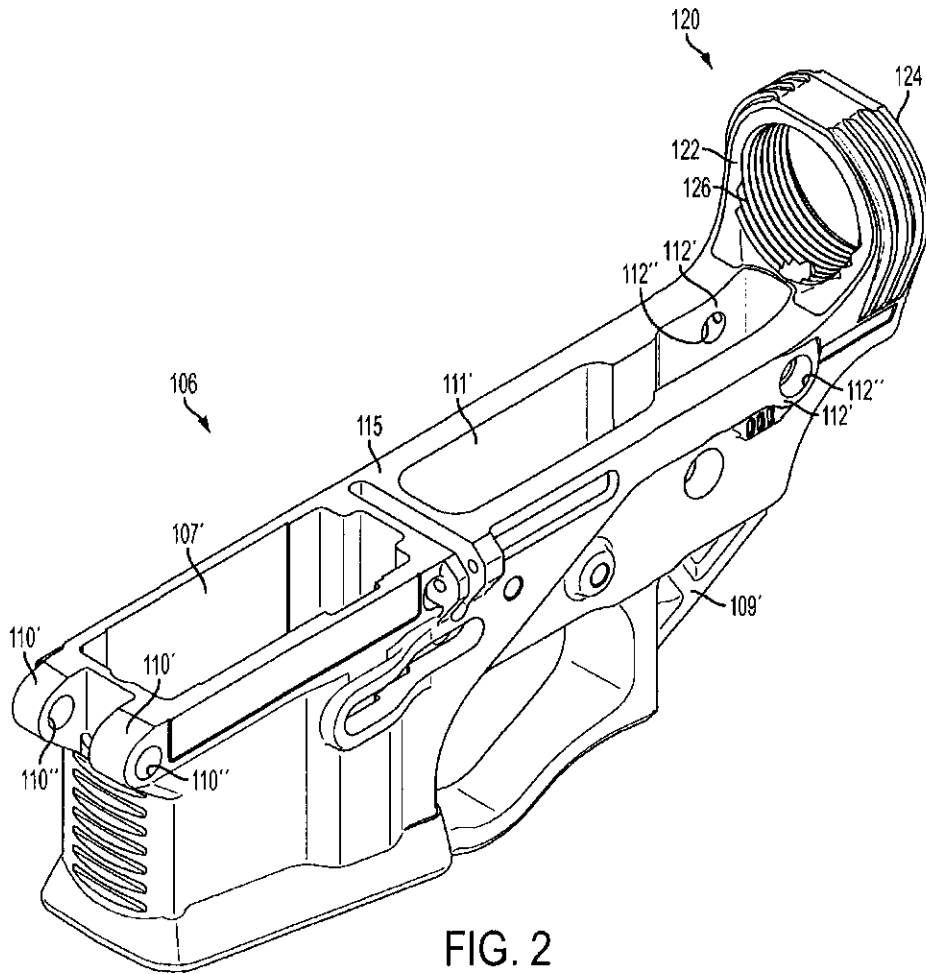

FIG. 1



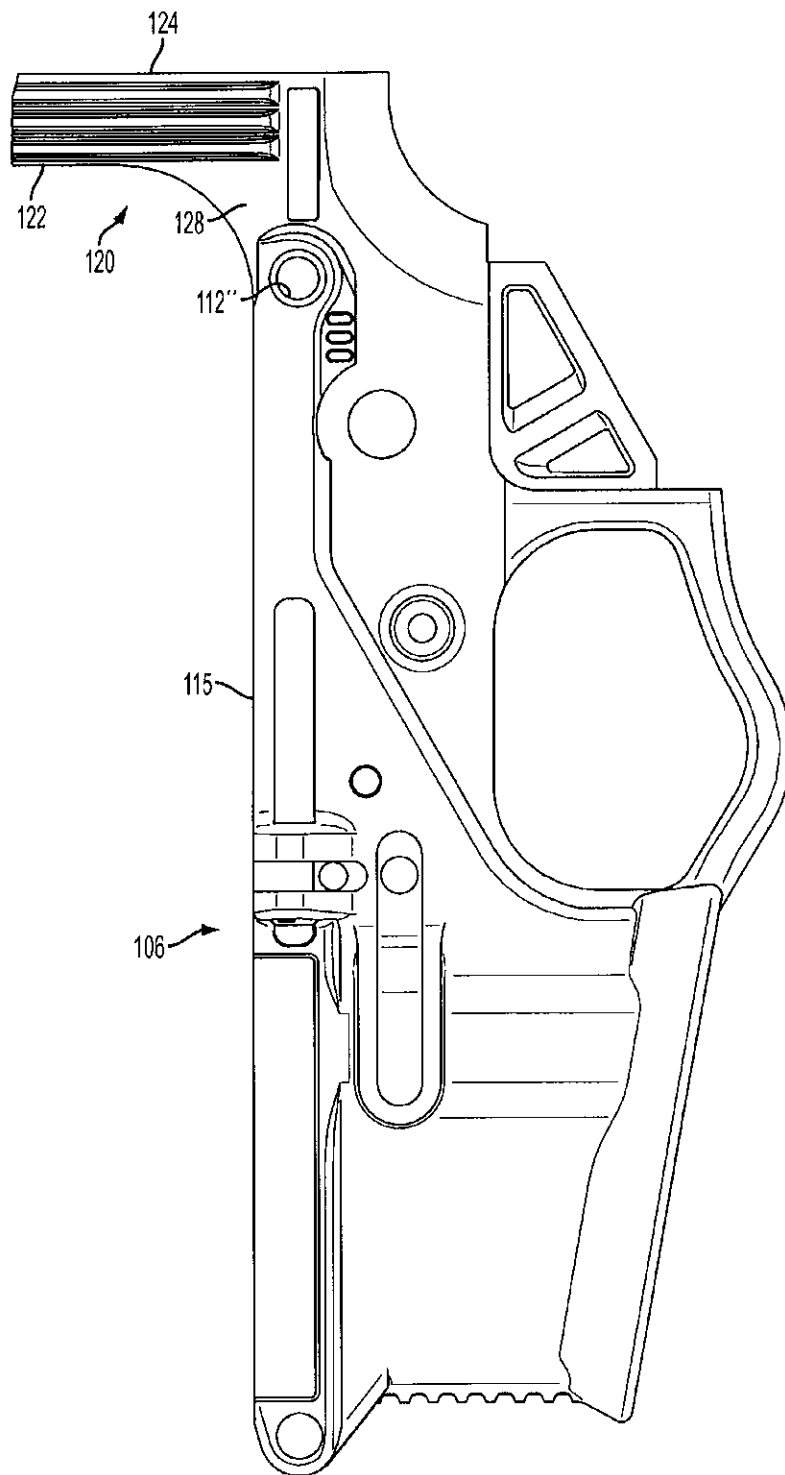

FIG. 3

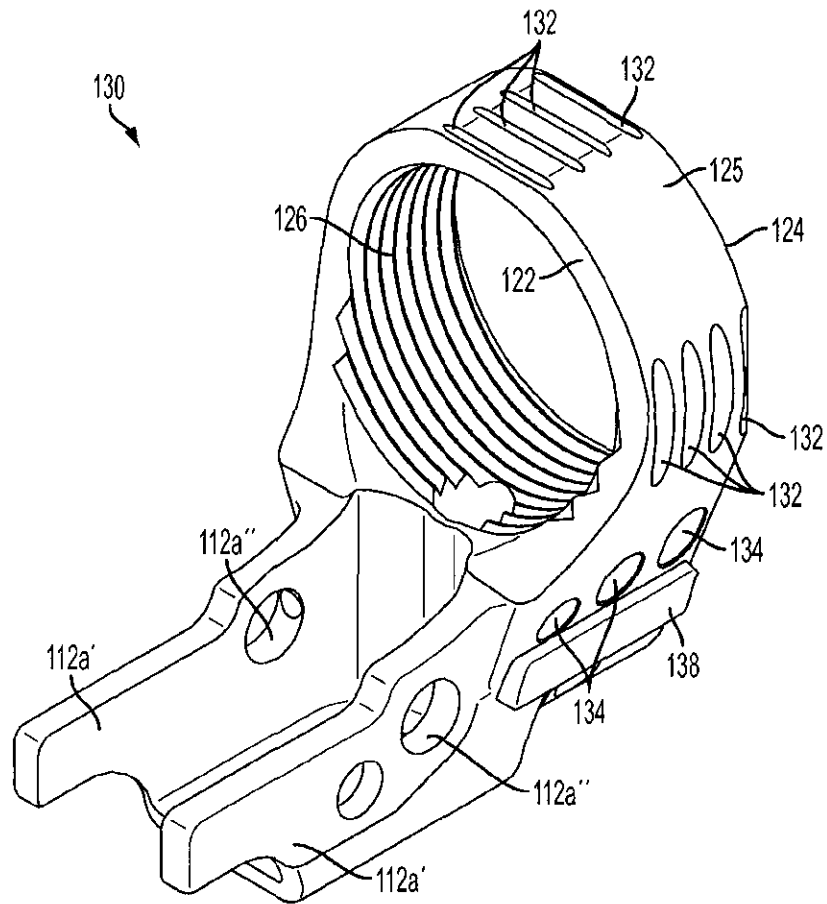

FIG. 4

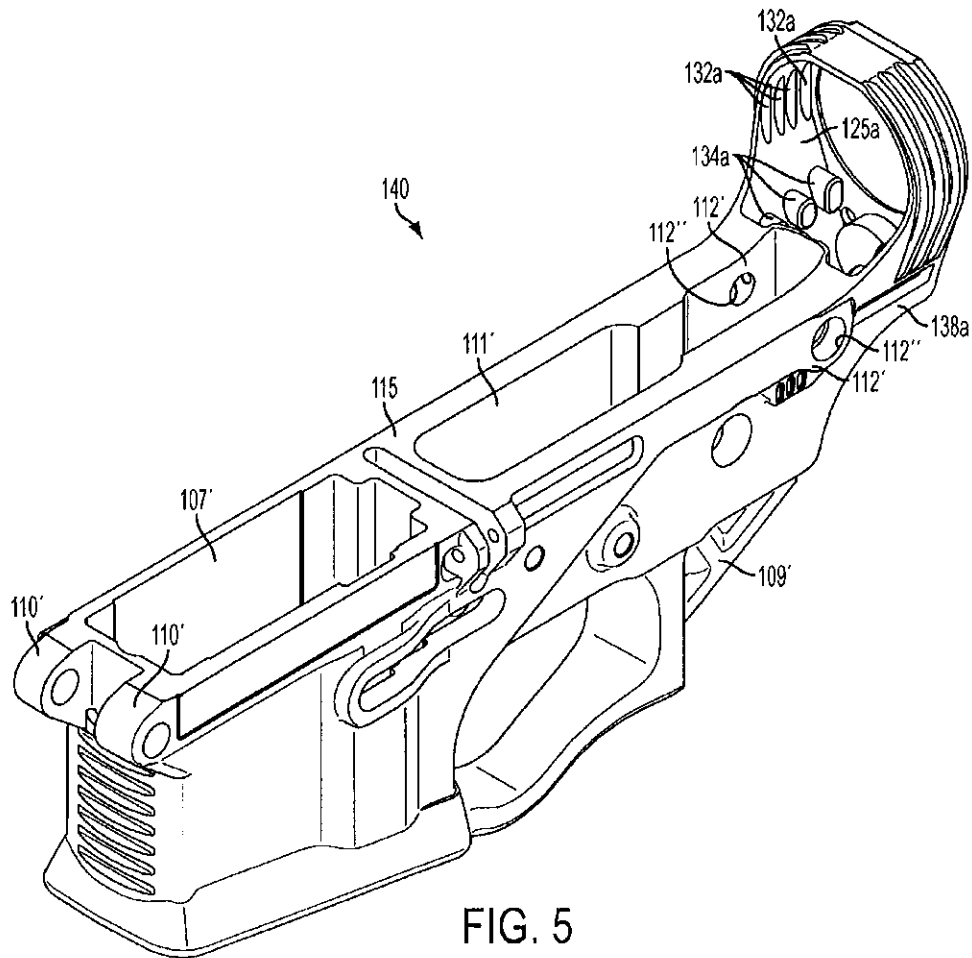

FIG. 5

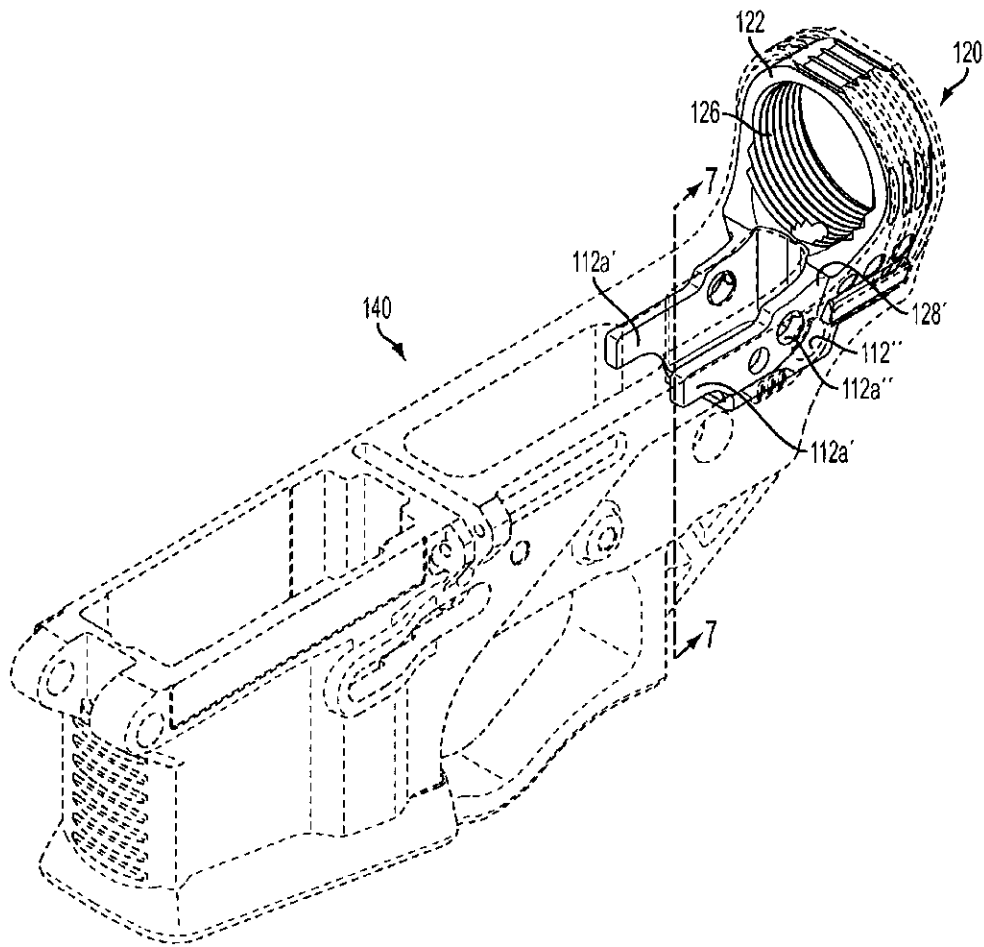

FIG. 6

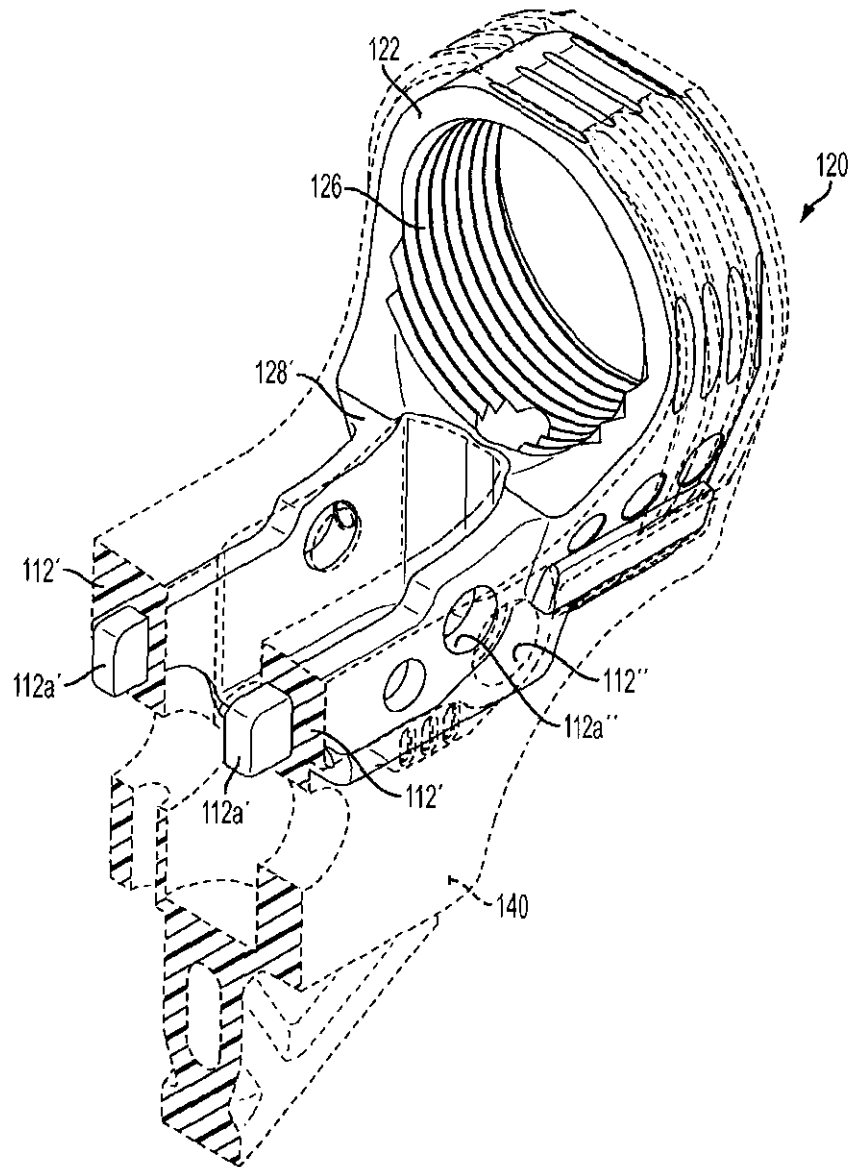

FIG. 7

US 8,789,305 B1

1

HYBRID LOWER RECEIVER FOR A RIFLE

FIELD OF THE INVENTION

The present invention relates to a rifle, and more particularly, to a modular automatic or semi-automatic assault-type rifle. Specifically, the present invention relates to a lower receiver assembly configured for use within a modular assault-type rifle.

BACKGROUND OF THE INVENTION

There are a number of automatic and semi-automatic rifles used by military personnel as well as law enforcement and civilians. While fully automatic rifles are generally illegal for use by the civilian population, many of the components which constitute an automatic rifle are the same as those found within semi-automatic models legalized for civilian use. Arguably the most popular semi-automatic assault-type rifle used by civilians, particularly within the United States, is the AR-15 and its clones. AR-15 is a registered trademark of Colt Industries. A number of additional companies manufacture clones of the AR-15 and market these clones under separate trademarks. While used throughout the specification, it is to be understood that the term AR-15 is meant to include not only those rifles manufactured by Colt Industries, but also those additional clones and any variants thereof. The AR-15 is the semi-automatic variant of the fully automatic M16 rifle used by United States military personnel.

The AR-15 and M16 are designed as modular rifles generally comprising a buttstock, lower receiver, upper receiver and barrel assembly. Each component is separable from one another and affords rifle owners the opportunity to customize the rifle with after-market components such as barrels of differing lengths, upper receivers designed to handle different calibers of ammunition, flashlights, hand guards, grenade or flare launchers, flash or sound suppressors, grips, and front or rear sights. To operate, the lower receiver is configured to include a trigger and magazine box wherein activation of the trigger causes a round (bullet) housed within the chamber of the upper receiver to be fired out the barrel of the rifle by action of a reciprocating bolt carrier group housed within the upper receiver. Internal mechanisms of the upper receiver expel the shell casing of the fired round from the chamber while components engaged with the magazine box housed within the lower receiver feed a new round into the now-empty chamber. The buttstock mounts to the lower receiver and includes a buffer assembly and action (or recoil) spring in communication with the bolt carrier group. After a spent shell has been discharged, the spring urges the bolt carrier group back toward the chamber in preparation for firing another round.

The modular construction of these rifles enables generally quick and easy field-stripping (disassembly of the rifle for cleaning of the rifle to ensure proper firing of the weapon). In field-stripping the rifle, the lower receiver is separated from the upper receiver to gain access to the firing mechanism (bolt, bolt carrier and associated mechanisms) for cleaning and re-lubrication. When assembled, the upper and lower receivers are secured to one another through rear and forward extensions on the upper receiver fitting between corresponding sidewalls forming notches or grooves on the lower receiver. The forward sidewalls and extension are fitted with a pivot pin to prevent the forward halves of the receivers from separating. Similarly, the rear sidewalls and extension employ a takedown pin to secure the two receivers together. To field-strip the rifle, the takedown pin is sufficiently pushed

2

out of the extension so as to enable the rear extension to lift out of the rear sidewalls thereby pivoting the lower and upper receivers about the pivot pin. The pivot pin can then be pushed out a sufficient distance so as to enable removal of the front extension from the front sidewalls and thereby completing separation of the lower receiver from the upper receiver.

While the AR-15 and M16 can be constructed of aircraft grade forged aluminum, a trend in manufacturing current firearms/firearm components is to interchange metal parts/components with high strength polymeric materials, such as glass reinforced nylon, whenever possible. These polymeric parts/components decrease the weight of the rifle while also decreasing material costs associated with fabrication of the rifle or individual rifle parts. One drawback in polymeric components, however, is the eventual wear of these components after repeated field-stripping, cleaning and reassembly. This is of particular importance with regard to the lower receiver and the takedown and pivot pins. Any substantial wear to any of the components results in an unsafe and unusable firearm. A further drawback to a polymeric lower receiver is the potential for fatigue or cracking of the lower receiver upon dropping of the weapon. Specifically, the lower receiver includes an upper lobe which is used to mount a receiver extension (which is housed within the buttstock) to the lower receiver. The buffer assembly and action (recoil) spring is housed within this receiver extension. Dropping the rifle such that the buttstock strikes a surface with sufficient force or at an angle, or after repeated drops, the polymeric upper lobe can crack or completely fracture from the remainder of the lower receiver thereby causing misalignment between the buffer assembly and bolt carrier group resulting in a dangerous or inoperable firearm.

As such, there is a need for a lower receiver assembly which capitalizes upon the weight and cost savings afforded by polymeric materials while also enjoying the mechanical and structural strength afforded by metal (i.e. aircraft grade aluminum). The present invention addresses these and other needs.

BRIEF SUMMARY OF THE INVENTION

In general, one embodiment of the present invention is directed to a lower receiver assembly constructed as a polymeric/metal hybrid wherein the bulk of the lower receiver assembly is constructed of molded polymeric materials while at least a portion of the upper lobe is constructed of a metal.

Preferably, the metal portion of the upper lobe is configured to be surrounded by the polymeric portion of the hybrid lower receiver such that the upper lobe is a single, contiguous construction with the remainder of the lower receiver. The metal portion is positioned so as to engage the receiver extension and rifle buttstock. More preferably, the metal portion further extends to occupy at least a portion of the rear sidewalls of the lower receiver such that the takedown pin passes through the metal portion when attaching the lower receiver to the upper receiver.

Accordingly, in one embodiment of the present invention, a combination polymeric/metal lower receiver for use in a rifle is provided. The lower receiver is adapted for removable attachment to a buttstock including a receiver extension having a recoil spring and buffer assembly, and an upper receiver having a bolt, bolt carrier and charging handle. The lower receiver includes a polymeric lower receiver housing having an integral polymeric upwardly extending lobe. A metal insert is secured within the polymeric lower receiver at the location of the lobe. The metal insert is preferably configured to permit detachable engagement of the hybrid lower receiver

US 8,789,305 B1

3

with the receiver extension component of the rifle assembly while the polymeric receiver housing is adapted to permit detachable engagement with the upper receiver component of the rifle assembly.

The metal insert may further include a pair of spaced side walls which may extend within the spaced side walls of the polymeric lower receiver housing, respectively. The metal insert and polymeric lower receiver housing may further include aligned through-holes wherethrough a takedown pin may removably pass to secure the upper receiver component of the rifle assembly to the hybrid lower receiver.

In a further embodiment, the hybrid lower receiver includes a metal inserted adapted to display an elevated plate through a corresponding opening in the polymeric housing. The elevated plate displays component identifiers, such as through casting or engraving, in compliance with applicable state, federal and/or international laws and regulations.

The embodiments of the present invention are well-suited to reduce material costs while also maintaining structural integrity of the lower receiver assembly even after multiple cleanings of the rifle or when subjected to severe or repeated drops.

Additional objects, advantages and novel features of the present invention will be set forth in part in the description which follows, and will in part become apparent to those in the practice of the invention, when considered with the attached figures.

BRIEF DESCRIPTION OF THE DRAWINGS

The accompanying drawings form a part of this specification and are to be read in conjunction therewith, wherein like reference numerals are employed to indicate like parts in the various views, and wherein:

FIG. 1 is a side view of a representative modular rifle suitable for incorporating an embodiment of a lower receiver in accordance with present invention;

FIG. 2 is a perspective view of a lower receiver in accordance with an embodiment of the present invention;

FIG. 3 is a side view of a lower receiver in accordance with an embodiment of the present invention;

FIG. 4 is a perspective view of a metal insert incorporated within a lower receiver in accordance with an embodiment of the present invention;

FIG. 5 is a perspective view of a polymeric lower receiver housing in accordance with an embodiment of the present invention;

FIG. 6 is an environmental view of a lower receiver in accordance with an embodiment of the present invention showing an embedded metal insert in solid lines with a polymeric lower receiver housing shown in dashed lines; and

FIG. 7 is a cross-sectional view of a lower receiver in accordance with an embodiment of the present invention as taken generally along the line 7-7 of FIG. 6.

DETAILED DESCRIPTION OF THE INVENTION

Referring to the drawings in detail, and specifically to FIG. 1, a rifle, such as the AR-15, is generally indicated by reference numeral 100. Rifle 100 is a modular firearm consisting of a number of components and subcomponents. Major components of rifle 100 include barrel assembly 102, upper receiver 104, lower receiver 106 and buttstock 108. To assemble a completed rifle, upper receiver 104 is positioned atop lower receiver 106 such that front and rear projections on the upper receiver (not shown) rest within a notch or groove formed by sidewalls 110' and 112', respectively, of the lower

4

receiver (see FIG. 2). Each projection and respective side-walls include a corresponding through-hole. Sidewall through-holes 110" and 112" are configured to align with a respective through-hole of the upper receiver whereby a pin is inserted into and passes within each through-hole to secure the two receivers together. Pivot pin 110 detachably secures the front projection of the upper receiver within the lower receiver while takedown pin 112 secures the rear projection.

Upper receiver 104 houses the chamber 105 which holds a round (bullet) in position for firing, along with the firing mechanism to initiate discharge of the round. The firing mechanism generally includes a bolt, bolt carrier, charging handle and related mechanisms. Barrel assembly 102 is secured to upper receiver 104 generally through a threaded connection and includes a barrel 103 in operational communication with the chamber of the upper receiver such that a round fired from the chamber 105 passes down the length of the barrel and exits the firearm at barrel end 103'. Rounds are introduced into the chamber by way of magazine 107 fitted to the lower receiver. Activation of the firing mechanism is controlled by trigger 111. A grip 109 (such as a pistol grip, as shown) allows the user to aim and control the rifle while placing the user's trigger index finger in close proximity to the trigger. In this manner, the user can aim the rifle to the target and extend the trigger index finger to engage the trigger without losing control or accuracy of the rifle.

Lower receiver 106 includes an upwardly extending lobe 120 (see FIG. 2). Buttstock 108 is detachably mounted to upwardly extending lobe 120 so that a receiver extension 113 is in operational alignment with the bolt carrier housed within the upper receiver. Receiver extension 113 generally houses an action (or recoil) spring and buffer assembly (not shown). Upon discharge of a round, the bolt carrier within the upper housing is driven rearward by action of the gas discharged by the firing action. The buffer assembly and action spring dampen the kickback experienced by the user while also redirecting the firing mechanism back toward the chamber in preparation for firing another round.

Modular rifles are generally constructed of aircraft grade forged aluminum. However, a current manufacturing trend is to interchange metal parts/components with high strength polymeric materials, such as glass reinforced nylon, whenever possible, including both the upper and lower receivers. Polymeric parts/components decrease the weight of the rifle while also decreasing material costs associated with fabrication of the rifle parts. One drawback in polymeric components, however, is the eventual wear of these components after repeated field-stripping, cleaning and reassembly. This is of particular importance with regard to the lower receiver and the takedown and pivot pins. Any substantial wear to any of these particular components results in an unsafe and unusable firearm. A further drawback to a polymeric lower receiver is the potential for fatigue or cracking of the lower receiver upon dropping of the weapon, particularly where the upwardly extending lobe begins its upward projection from the main body of the lower receiver. The upper lobe 120 of the lower receiver is used to mount the receiver extension 113 (See FIG. 1). Repeated or violent dropping of the rifle, particularly drops causing the buttstock 108 (within which is housed receiver extension 113) to strike a surface with sufficient force and/or at an angle can cause the upwardly extending lobe to crack, fracture or shear from the remainder of the lower receiver thereby causing misalignment between the buffer assembly and bolt carrier group resulting in a dangerous or inoperable firearm.

As shown in FIGS. 2 and 3, lower receiver 106 has a generally rectangular side profile and includes an upwardly

US 8,789,305 B1

5

extending lobe 120. Top surface 115 is a generally flat surface configured with openings for accepting the internal mechanisms required to operate the rifle. For instance, opening 107' is configured to accept an ammunition magazine 107 and associated hardware to direct rounds loaded within the magazine into the chamber in the upper receiver. Opening 111' houses mechanical components which engage the trigger 111 with the bolt carrier group in the upper receiver so that manipulation of the trigger results in firing of the rifle. Lower receiver 106 is further adapted with a grip mounting interface 109' for securing, for example, a pistol grip 109.

When assembled (as shown in FIG. 1), the upper receiver 104 mounts along lower receiver top surface 115 and abuts inner surface 122 of the upwardly extending lobe 120. Outer surface 124 of the upwardly extending lobe 120 engages with receiver extension 113 to mount buttstock 108 to lower receiver 106. Upwardly extending lobe 120 has a generally circular threaded through-hole 126 which is adapted to receive the mating male threads on the receiver extension 113. Through-hole 126 permits operational communication between the buffer assembly and action spring housed within the receiver extension (not shown) with the bolt carrier group (not shown) within the upper receiver which is mounted along top surface 115, as shown in FIG. 1. As shown most clearly in FIG. 3, upwardly extending lobe 120 forms a generally 90 degree elbow 128 with top surface 115. As the buttstock has a sole mounting surface along outer surface 124 of upwardly extending lobe 120, any force applied to the buttstock which is not along the longitudinal axis L of the rifle is directed at elbow 128. Repeated stress to elbow 128, such as by dropping the rifle on the buttstock, may lead to mechanical failure of the elbow, particularly when that elbow is constructed from a polymeric material.

Accordingly, as shown in FIGS. 4-7, the lower receiver of the present invention is constructed as an integrated hybrid polymer/metal unit wherein a metal insert 130 (FIG. 4) is secured within a polymeric lower receiver housing 140 (FIG. 5). Metal insert 130 can be constructed of any suitable metal, and is preferably constructed of aircraft grade aluminum. Similarly, the polymeric lower receiver housing 140 can be constructed of any suitable polymeric material, and is preferably constructed of glass reinforced nylon.

In a preferred embodiment, as seen in FIGS. 6 and 7, metal insert 130 includes the interior portion of upwardly extending lobe 120, and more specifically defines the threaded through-hole 126, as well as the inner surface 122 and outer surface 124 which contact the upper receiver and receiver extension, respectively. As the threaded through-hole 126 is constructed out of the metal insert 130, the internal threads of the upwardly extending lobe gain the benefits of an all-metal lower receiver (more robust threads that are less likely to become stripped or cross-threaded upon repeated engagement/disengagement of the corresponding threads of the receiver extension 113) while the remainder of lower receiver gains the benefits of a polymeric lower receiver (lighter materials and less expensive material and fabrication costs).

As seen in FIG. 4, exterior surface 125 of the metal insert 130 is preferably adapted to include a plurality of recess 132 and wells 134. Exterior surface 125 is configured to mate with interior surface 125a of polymeric housing 140. Directing attention to FIG. 5, polymeric housing 140 further includes protrusions 132a which engage recesses 132 and nodules 134a which engage wells 134. Mating elements 132/132a and 134/134a lock the metal insert within the polymeric housing and prevent lateral displacement of the metal insert when subjected to a kickback force (such as that experienced immediately following discharge of the rifle) or when the lower

6

receiver is being physically tampered with by a user. While described as having a metal insert with recesses and wells and a polymeric housing with protrusions and nodules, it would be appreciated by one skilled in the art that the orientation of these features can be reversed or combined in any suitable configuration so as to perform the intended function.

Turning again to FIGS. 6 and 7, metal insert 130 further extends through an elbow 128' to define sidewalls 112a' having takedown pin through-holes 112a". Preferably sidewalls 112a' are embedded within polymeric sidewalls 112' such that metal insert takedown pin through-holes 112a" correspond with takedown pin through-holes 112" situated on the polymeric housing 140 thereby enabling selective engagement/disengagement of takedown pin 112. Metal sidewalls 112a' defining through-holes 112a" minimize wear to the lower receiver and takedown pin when the lower receiver is separated from the upper receiver for cleaning and re-lubrication. Metal sidewalls 112a', by extending through the elbow to form a unitary metal insert with the threaded portion of the upwardly extending lobe 120, increases the structural stability of the elbow of the integrated polymer/metal hybrid lower receiver. This hybrid polymer/metal elbow resists cracking or fracturing such as that experienced by a solely polymeric lower receiver while also minimizing component weight and manufacturing costs by decreasing the amount of the metal used to construct the lower receiver.

In a further embodiment, metal insert 130 is fabricated to include an elevated plate 138. Elevated plate 138 is incorporated in and passes through plate opening 138a on polymeric housing 140. Elevated plate 138 allows for the marking of a serial number or other identifier upon the lower receiver in compliance with 27 C.F.R. §479.102. In a preferred embodiment, the elevated plate 138 is conspicuously placed on the lower receiver and, by being incorporated within the metal insert, is not susceptible to being readily obliterated, altered or removed. The size, position and/or orientation of the elevated plate can be modified as desired or necessitated so as to enable marking of the lower receiver in satisfaction of any state, federal or international law or regulation.

Although the present invention has been described in considerable detail with reference to certain aspects thereof, other versions are possible. Therefore, the spirit and scope of the appended claims should not be limited to the description of the aspects contained herein.

All features disclosed in the specification, including the claims, abstract, and drawings, and all the steps in any method or process disclosed, may be combined in any combination, except combinations where at least some of such features and/or steps are mutually exclusive. Each feature disclosed in the specification, including the claims, abstract, and drawings, can be replaced by alternative features serving the same, equivalent or similar purpose, unless expressly stated otherwise. Thus, unless expressly stated otherwise, each feature disclosed is one example only of a generic series of equivalent or similar features.

What is claimed is:

1. A combination metal/polymer lower receiver for use in a rifle, the lower receiver being adapted to be detachably attached to a buttstock including a receiver extension having a recoil spring and buffer assembly, and an upper receiver having a bolt, bolt carrier and charging handle, the lower receiver comprising:

a) a polymeric lower receiver housing having an integral polymeric upwardly extending lobe configured to receive the receiver extension therethrough, the polymeric lower receiver housing adapted to detachably

US 8,789,305 B1

7

8

engage with mounting features on the upper receiver to
attach said lower receiver to said upper receiver; and
b) a metal insert rigidly secured within the polymeric
upwardly extending lobe wherein the metal insert is
adapted to detachably engage the receiver extension. 5

2. The combination metal/polymer lower receiver of claim
1 wherein said metal insert further includes insert side walls
embedded within respective polymer sidewalls of said poly-
meric lower receiver housing such that the polymer/metal
side walls are adapted to detachably engage a rear mounting 10
feature of said upper receiver.

3. The combination metal/polymer lower receiver of claim
1 wherein said metal insert further includes an elevated plate,
wherein the elevated plate is disposed within a plate opening
on said polymeric lower receiver housing. 15

* * * * *

EXHIBIT 2

Search Tennessee Arms Company



Need Assistance?
Call 731-334-5106

View My Order
0 item(s) 0.00

HOMEPAGE FIREARMS RECEIVERS PARTS ACCESSORIES APPAREL SALE LOGIN DEALERS INFO SITE MAP

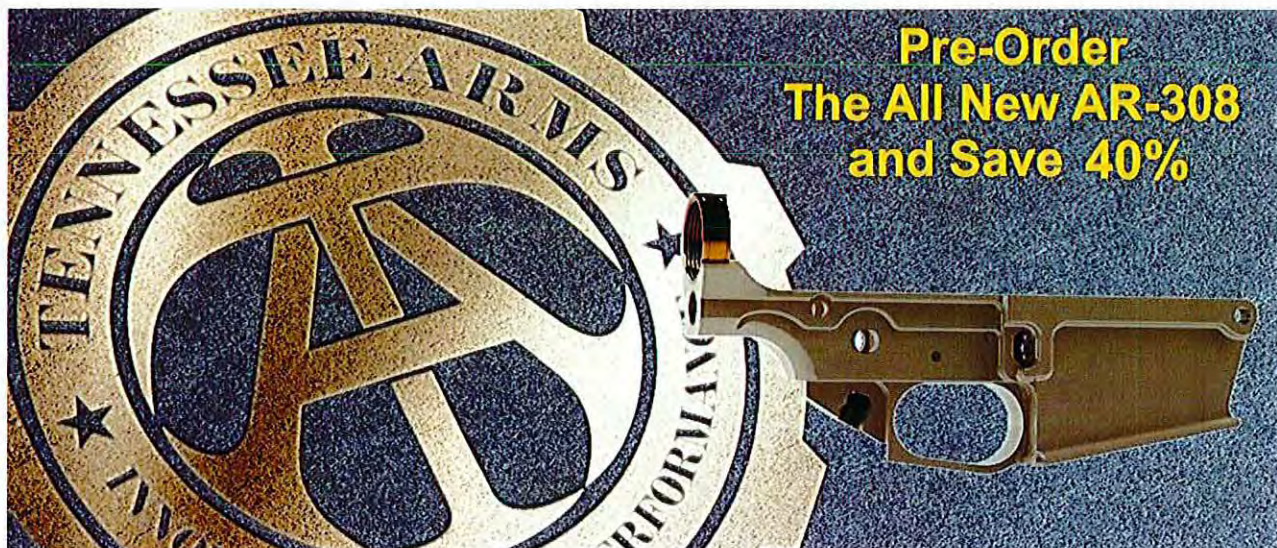

Current Featured Products



Weekend Sale Two Receiver Bundle - Your Choice of 2 Receivers-Free Shipping
\$79.25

CHOOSE OPTIONS



Laser Engraved Lowers-New Designs on File
\$53.48

CHOOSE OPTIONS



AR-308 PRESALE Available First Quarter 2015 30% OFF
\$103.43

CHOOSE OPTIONS



Tennessee Arms Men's 3/4 Sleeve Jersey
\$21.00

ADD TO CART

Tennessee Arms Company - Recent News

We have launched our new Ghost Gun. The industry's first and only clear lower receiver. This receiver is intended as a display model and is fully functional, But is not intended for duty use. This receiver is also the lightest AR style receiver that has ever been produced. Weighing in at a mere 3.6 ounces this is a fraction of the weight of our hybrid polymer receiver (5.6 ounces) which in itself is much lighter than a standard lower.

Hybrid Lower Receiver

The Tennessee Arms Company, LLC lower is the cutting edge of rifle design. Using a patent-pending threaded insert in our Nylon Receivers we can achieve remarkable strength with a significant weight savings. By using our hybrid design we are able to offer a receiver that is color matched to the rest of your receiver and provides the unfailing toughness that we demand out of a rifle. Our receivers are truly the next step for the AR platform.

Pages	Categories	Industry Partners	Connect with us
Home Login Dealers Info Site Map	Firearms Receivers Parts Accessories Apparel Sale View all categories	Way Of The Gun Rogue American Rogue Gunfighter Chambers Custom HighThreatConcealment	Join Our Mailing List 

Copyright 2014 Tennessee Arms Co LLC. Content & Development by Third Eye Graphic Solutions



Search Tennessee Arms Company



Need Assistance?
Call 731-334-5106

View My Order
0 item(s) 0.00

HOME PAGE FIREARMS RECEIVERS PARTS ACCESSORIES APPAREL SALE LOGIN DEALERS INFO SITE MAP

Search

SHOW SEARCH FORM

Search Results for "Hybrid Polymer Lower Receiver"

Products News & Information

Did you mean to browse one of the following categories instead?

- Parts > Lower Receiver Parts
- Receivers
- Parts > Upper Receiver Parts
- Receivers > Complete Lowers
- Receivers > Stripped Lowers
- Apparel

1 2 Sort by: Relevance



TAC Hybrid Receiver in Pink

\$46.27

Tennessee Arms Company is proud to offer our hybrid polymer/ metal lower receiver. This stripped receiver is designed to accept any mil-spec lower parts kit. All colors are molded directly into and throughout the entire receiver so you never have to...



Complete Lower Receiver w/CMMG Metal Parts Kit

\$149.00

Our Complete Lower Receiver is Built in House Using our Stripped Hybrid Lower CMMG Lower Parts Kit and a Commercial Diameter Six Position Collapsible Stock. Lifetime Warranty Receiver Constructed of High-Strength Nylon 6-6 and...

CHOOSE OPTIONS



TAC Hybrid Receiver in Sand Tan

\$46.27

Tennessee Arms Company is proud to offer our hybrid polymer/ metal lower receiver. This stripped receiver is designed to accept any mil-spec lower parts kit. All colors are molded directly into and throughout the entire receiver so you never...

ADD TO CART

TAC Hybrid Receiver in OD Green



\$46.27

Excerpt from a Third Party Review at <http://www.apexgunsmithing.com/poly-receivers-testing-part-2/> "I honestly can't find any sort of practical test that would harm this receiver or make it in any way inferior to an aluminum one."-...

ADD TO CART

TAC Hybrid Receiver in Army Foliage

\$46.27

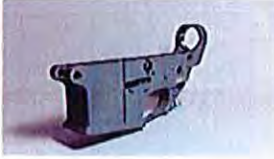

Excerpt from a Third Party Review at <http://www.apexgunsmithing.com/poly-receivers-testing-part-2/> "I honestly can't find any sort of practical test that would harm this receiver or make it in any way inferior to an aluminum one."-...

ADD TO CART

TAC Hybrid Receiver in Dark Earth

\$46.27



Excerpt from a Third Party Review at <http://www.apexgunsmithing.com/poly-receivers-testing-part-2/> "I honestly can't find any sort of practical test that would harm this receiver or make it in any way inferior to an aluminum..."

ADD TO CART

Hybrid Nylon 6-6/Brass Receiver + CMMG Lower Parts Kit

\$99.00



Your Choice of Hybrid Receiver + CMMG Single Stage Lower Parts Kit only \$99.00 SHIPPED! Excerpt from a Third Party Review at <http://www.apexgunsmithing.com/poly-receivers-testing-part-2/>...

CHOOSE OPTIONS

TAC Hybrid Receiver in Black

\$41.27



Unblemished Hybrid Stripped Lower Receiver Nylon 6-6 Body Marine Grade Brass inserts in Buffer Tower and Pistol Grip Lifetime Warranty against Breakage or Failure Available in Colors Excerpt from a Third Party Review at ...

ADD TO CART

TAC Hybrid Nylon 6-6/Brass Receiver in Rifle Green

~~\$55.00~~ \$46.27



Excerpt from a Third Party Review at <http://www.apexgunsmithing.com/poly-receivers-testing-part-2/> "I honestly can't find any sort of practical test that would harm this receiver or make it in any way inferior to an aluminum one..."

Four Receiver Bundle- Four (4) Nylon 6-6/Brass Hybrid Stripped Lowers- Shipping Included

\$146.48

4 Receivers-You Pick the Colors Free Shipping Excerpt from a Third Party Review at <http://www.apexgunsmithing.com/poly-receivers-testing-part-2/> "I honestly can't find any sort of practical test that would harm..."



CHOOSE OPTIONS

Single Hybrid Nylon 6-6/Brass Stripped Receivers Starting at \$41.27

\$41.27

Excerpt from a Third Party Review at http://www.apexgunsmithing.com/poly-receivers-testing-part-2/ "I honestly can't find any sort of practical test that would harm this receiver or make it in any way inferior to an aluminum..."

CHOOSE OPTIONS



Weekend Sale Two Receiver Bundle - Your Choice of 2 Receivers-Free Shipping

\$79.25

Your Choice of Any Two (2) Hybrid Nylon 6-6/Brass Hybrid Receivers-79.29 Shipped Lifetime Warranty Constructed of High-Strength Nylon 6-6 and Marine-Grade Brass inserts 5.6oz stripped Excerpt from Guns And Ammo...

CHOOSE OPTIONS



Ten (10) Stripped Hybrid Nylon 6-6/Brass Lowers-FREE SHIPPING

\$365.23

10 Receivers-You Pick the Colors Free Shipping Pink and Rifle Green Available on 7-16-14 Excerpt from a Third Party Review at http://www.apexgunsmithing.com/poly-receivers-testing-part-2/ "I honestly can't find any..."

CHOOSE OPTIONS



Weekly Special-Three Receiver Bundle (3)- Free Shipping

\$117.76

Your Choice of Any Three (3) Gen IV Hybrid Receivers-117.76 Lifetime Warranty Constructed of High-Strength Nylon 6-6 and Marine-Grade Brass inserts 5.6oz stripped Excerpt from a Third Party Review at http://www...

CHOOSE OPTIONS



Ghost Gun- Clear Stripped Lower Receiver

\$55.77

We are proud to offer our Clear Stripped Lower Receiver we are calling the "Ghost Gun." This lower is made as a training tool and product showcase model that is usable but is not designed for the rugged use that our fiber-reinforced Nylon models are...

ADD TO CART



5 Five Receiver Bundle For 186.90 includes Shipping

\$186.90

5 Receivers-You Pick the Colors Free Shipping Excerpt from a Third Party Review at GUNS.COM "Ultimately these reinforced Nylon receiver can handle abuses that would outright destroy an aluminum receiver and bounce right back..."

CHOOSE OPTIONS

 View Results as RSS Feed

Pages	Categories	Industry Partners	Connect with us
Home	Firearms	Way Of The Gun	Join Our Mailing List 
Login	Receivers	Rogue American	
Dealers Info	Parts	Rogue Gunfighter	
Site Map	Accessories	Chambers Custom	
	Apparel	HighThreatConcealment	
	Sale		
	View all categories		
<small>Copyright 2014 Tennessee Arms Co LLC. Commerce Development by Third Eye Graphic Solutions</small>			



Search Tennessee Arms Company



Need Assistance?
Call 731-334-5106

View My Order
0 item(s) 0.00

HOME PAGE FIREARMS RECEIVERS PARTS ACCESSORIES APPAREL SALE LOGIN DEALERS INFO SITE MAP

Categories

- Firearms
- Receivers
- Parts
- Accessories
- Apparel
- Sale

Shop by Price

- \$0.00 - \$107.00
- \$107.00 - \$172.00
- \$172.00 - \$236.00
- \$236.00 - \$301.00
- \$301.00 - \$366.00

Home Receivers

Receivers

Sort by: Featured Items

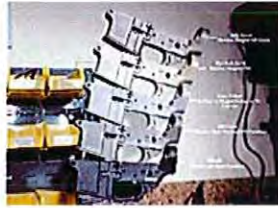

Four Receiver Bundle- Four (4)
Nylon 6-6/Brass Hybrid Stripped
Lowers-Shipping Included

\$146.48

CHOOSE OPTIONS



Stripped Receiver+Dagger Muzzle
Device-\$82.50 SHIPPED

\$82.50

CHOOSE OPTIONS



5 Five Receiver Bundle For 186.90
includes Shipping

\$186.90

CHOOSE OPTIONS



AR-308 PRESALE Available First
Quarter 2015 30% OFF

\$103.43

CHOOSE OPTIONS



Complete Ghost Gun Lower
w/CMMG Single Stage Trigger

\$179.00

ADD TO CART



Complete Lower Receiver
w/CMMG Metal Parts Kit

\$149.00

CHOOSE OPTIONS



Ghost Gun- Clear Stripped Lower Receiver

\$55.77

ADD TO CART



Hybrid Nylon 6-6/Brass Receiver + CMMG Lower Parts Kit

\$99.00

CHOOSE OPTIONS



Laser Engraved Lowers-New Designs on File

\$53.48

CHOOSE OPTIONS



Single Hybrid Nylon 6-6/Brass Stripped Receivers Starting at

\$41.27

\$41.27

CHOOSE OPTIONS



TAC Hybrid Receiver in Army Foliage

\$46.27

ADD TO CART



TAC Hybrid Receiver in Dark Earth

\$46.27

ADD TO CART



TAC Hybrid Receiver in OD Green

\$46.27

ADD TO CART



TAC Hybrid Nylon 6-6/Brass Receiver in Rifle Green

~~\$55.00~~ \$46.27

ADD TO CART



TAC Hybrid Receiver in Black

\$41.27

ADD TO CART



TAC Hybrid Receiver in Pink

\$46.27

ADD TO CART



TAC Hybrid Receiver in Sand Tan

\$46.27

ADD TO CART

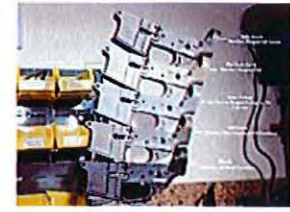

Ten (10) Stripped Hybrid Nylon 6-6/Brass Lowers-FREE SHIPPING

\$365.23

CHOOSE OPTIONS

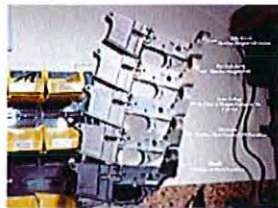

Weekend Sale Two Receiver Bundle - Your Choice of 2 Receivers-Free Shipping

\$79.25

CHOOSE OPTIONS

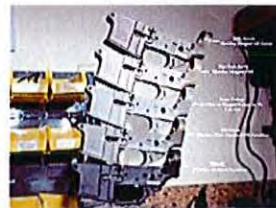

Weekly Special-Three Receiver Bundle (3)- Free Shipping

\$117.76

CHOOSE OPTIONS

Pages

- Home
- Login
- Dealers Info
- Site Map

Categories

- Firearms
- Receivers
- Parts
- Accessories
- Apparel
- Sale
- [View all categories](#)

Industry Partners

- Way Of The Gun
- Rogue American
- Rogue Gunfighter
- Chambers Custom
- HighThreatConcealment

Connect with us

Join Our Mailing List



Copyright 2014 Tennessee Arms Co. LLC. Commerce Development by Third Eye Graphic Solutions



Search Tennessee Arms Company



Need Assistance?
Call 731-334-5106

View My Order
0 item(s) 0.00

HOMEPAGE FIREARMS RECEIVERS PARTS ACCESSORIES APPAREL SALE LOGIN DEALERS INFO SITE MAP

Home Receivers AR-308 PRESALE Available First Quarter 2015 30% OFF



AR-308 PRESALE Available First Quarter 2015 30% OFF

\$103.43

Weight: 0.33 LBS

Shipping: Calculated at checkout

Color:
-- Please Choose an...

Quantity 1

ADD TO CART

SAVE TO WISHLIST

Share

Expected release date is 02/01/2015



Related Products



Complete Lower Receiver w/CMMG Metal Parts Kit

\$149.00

CHOOSE OPTIONS



TNARMS-15 5.56/.223 Rifle

\$1,239.00 \$899.00

CHOOSE OPTIONS



TNARMS 15 Survival Rifle

\$998.00

CHOOSE OPTIONS

Product Description

We are proud to introduce our newest product, the AR-308. Designed to accept a DPMS pattern upper receiver and engineered with our patent pending threaded metal inserts, the AR-308 is the cutting edge of the heavy caliber rifle receivers. Made from a high-grade Nylon with fiber-reinforcement, our receiver will be lighter and more durable than the anodized aluminum receivers they are replacing. We are offering these receivers in presale so that our customers can take advantage of our September offer of 40% off the price of retail. Our retail price will be 147.77. To introduce these lowers to the shooting community, the price will be adjusted toward the retail price as we near production. Estimated delivery date is within the first quarter of 2015.

Designed using our experience in building the 5.56 version as a guide, we have reinforced every stress point in the receiver. The TNARMS-15 is already on the market mounted to customer's .450 Bushmaster uppers and .50 Beowulf uppers with zero returns from part failure in any caliber. The AR-308 has approximately 30 percent more mass and is reinforced by design. All of our products come with a lifetime guarantee. Dealer Sales are OK with no max amount.

Find Similar Products by Category

Product Reviews

Customers Who Viewed This Product Also Viewed



Ghost Gun- Clear Stripped Lower Receiver

\$55.77

ADD TO CART



Complete Lower Receiver w/CMMG Metal Parts Kit

\$149.00

CHOOSE OPTIONS



Laser Engraved Lowers-New Designs on File

\$53.48

CHOOSE OPTIONS



TNARMS 15 Survival Rifle w/ Kit

\$1,399.00

CHOOSE OPTIONS



NEW! Ladies Dark Heather Valkyrie Wings Crew Tee *Introductory Price

\$20.00

CHOOSE OPTIONS

Pages

- Home
- Login
- Dealers Info
- Site Map

Categories

- Firearms
- Receivers
- Parts
- Accessories
- Apparel
- Safe
- View all categories

Industry Partners

- Way Of The Gun
- Rogue American
- Rogue Gunfighter
- Chamber's Custom
- HighThreatConcealment

Connect with us

Join Our Mailing List



Copyright 2014 Tennessee Arms Co. LLC. Commerce Development by Third Eye Graphic Solutions



Tennessee Arms Company, LLC: New Products

You are viewing a feed that contains frequently updated content. When you subscribe to a feed, it is added to the Common Feed List. Updated information from the feed is automatically downloaded to your computer and can be viewed in Internet Explorer and other programs. [Learn more about feeds.](#)

 [Subscribe to this feed](#)

Engraving Specials- "Gungnir" or "Molon Labe"

Thursday, September 18, 2014, 6:31:09 AM

Engraving Special

Your Pick of

"Gungnir"(Spear of Odin)



Tennessee Arms Men's Hoodie

Monday, September 08, 2014, 8:39:17 AM

The Tennessee Arms Company 50/50 Cotton/Poly 8.0 oz Hoodie is now available.

Contrast Two-ply hood lining and flat drawcords w/Tn Arms Logo centered on the Fro..

Price: \$36.00 Not Rated



Tennessee Arms Men's 3/4 Sleeve Jersey

Monday, September 08, 2014, 8:14:05 AM

All Tn Arms Shirts are Made In House

The Tn Arms 3/4 Sleeve Jersey is made of 100% cotton. Featuring the distressed ..

Price: \$21.00 Not Rated



NEW! Men's Distressed Charcoal Logo Tee *Introductory Price

Thursday, August 28, 2014, 9:03:22 PM

All Shirts are Printed In House

All sizes Available from Small-2X

Lightweight-Perfect..

Price: \$21.00 Not Rated



NEW! Ladies Dark Heather Valkyrie Wings Crew Tee *Introductory Price

Thursday, August 28, 2014, 8:25:13 PM

All Shirts are Printed In House

All sizes Available from Small-2X

Lightweight-Perfect..

Price: \$20.00 Not Rated



Four Receiver Bundle- Four (4) Nylon 6-6/Brass Hybrid Stripped Lowers-Shipping Included

Tuesday, August 19, 2014, 7:59:50 AM

4 Receivers-You Pick the Colors

Free Shipping

Price: \$146.48 ★★★★★



Complete Ghost Gun Lower w/CMMG Single Stage Trigger

Tuesday, August 05, 2014, 8:01:29 AM

Complete Ghost Gun Lower
with CMMG Single Stage Trigger
1lb 13.6oz Total Weight

Price: \$179.00 Not Rated



AR-308 PRESALE Available First Quarter 2015 30% OFF

Thursday, July 31, 2014, 6:29:05 AM

We are proud to introduce our newest product, the AR-308. Designed to accept a DPMS pattern upper receiver and engineered with our patent pending threaded metal inserts, the AR-308 is the cutting edge of the heavy caliber rifle receivers. Made from a..

Price: \$103.43 Not Rated



Ghost Gun- Clear Stripped Lower Receiver

Thursday, July 24, 2014, 5:44:40 AM

We are proud to offer our Clear Stripped Lower Receiver we are calling the "Ghost Gun." This lower is made as a training tool and product showcase model that is usable but is not designed for the rugged us..

Price: \$55.77 ★★★★★



Ten (10) Stripped Hybrid Nylon 6-6/Brass Lowers-FREE SHIPPING

Monday, July 07, 2014, 5:51:48 AM

10 Receivers-You Pick the Colors

Free Shipping

Pink and Rifle Green Available on 7-16..

Price: \$365.23 ★★★★★

