

IN THE UNITED STATES DISTRICT COURT
FOR THE WESTERN DISTRICT OF TEXAS
EL PASO DIVISION

FILED

2014 SEP -4 AM 11:07

CLERK OF DISTRICT COURT
WESTERN DISTRICT OF TEXAS

BY _____
DEPUTY

STAGECOACH PUTTERS, LLC,

Plaintiff,

v.

TAYLOR MADE GOLF COMPANY, INC.,

Defendant.

§
§
§
§
§
§
§
§
§

Case No.

JUDGE DAVID GUADERRAMA

EP 14 CV 0331

PLAINTIFF'S ORIGINAL COMPLAINT

TO THE HONORABLE JUDGE OF SAID COURT:

Now Comes, STAGECOACH PUTTERS, LLC, by and through its attorney of record, R. Wayne Pritchard, P.E., of the law firm R. Wayne Pritchard, P.C., complaining of TAYLOR MADE GOLF COMPANY, INC., Defendant, and for cause of action would respectfully show the court as follows:

**I.
JURISDICTION**

1. This action arises pursuant to 35 USC §271, 281, 283, 284 and 285, as hereinafter more fully described.

**II.
VENUE**

2. Title 28 U.S.C. §1400 provides, in pertinent part, that any civil action for patent infringement may be brought in the judicial district where the defendant resides. Pursuant to 28 U.S.C. §1391(c), a defendant that is a corporation is deemed to reside in any judicial district in which it is subject to personal jurisdiction. Upon information and belief, Defendant routinely and systematically sell golf clubs within the State of Texas and this judicial district, including those clubs that are the subject of this action, therefore, Defendant is subject to personal jurisdiction within the Western District of Texas.

**III.
PARTIES**

3. Plaintiff is a Texas limited liability company having its principal place of business in El Paso, Texas.

4. TAYLOR MADE GOLF COMPANY, INC., is a corporation formed and existing pursuant to the laws of the State of California, which can be served through its registered agent, William Reimus, 5545 Fermi Court, Carlsbad, California 92008.

**IV.
PATENT INFRINGEMENT**

5. On March 28, 2006, United States Letters Patent No. 7,018,304 (the '304 Patent), a true and correct copy of which is attached hereto as Exhibit "A" and incorporated by reference for all purposes, for Putter Head, was duly and legally issued to BRENT W. BRADFORD. The '304 Patent has been assigned to Plaintiff.

6. Defendant TAYLOR MADE GOLF COMPANY, INC., manufactures, markets and sells, among other things, putters known as the Ghost Spider and has manufactured and sold putters known as Taylor Made Rossa Turismo 3 AGSI and Taylor Made Rossa Inza (the "Taylor Made Putters"), illustrations of which are attached hereto collectively as Exhibit "B" and incorporated by reference for all purposes.

7. Defendant TAYLOR MADE GOLF COMPANY, INC., has for an undetermined amount of time in the past and is currently infringing the afore mentioned Letters Patent by making, selling and using the Taylor Made Putters. Defendant will continue to infringe the patented invention unless enjoined by this Court.

8. Plaintiff has placed the required statutory notice on all golf putters manufactured and sold by it under the afore mentioned Letters Patent, and has given written notice to Defendant of its infringement of the patented invention. Defendant's continued infringement of the '304 Patent constitutes willful infringement allowing Plaintiff to recover additional damages as set forth in 35 USC §284 as well as attorneys' fees as provided for in 35 USC §285.

V.
PATENT INFRINGEMENT

9. On November 25, 2003, United States Letters Patent No. 6,652,390 (the '390 Patent), a true and correct copy of which is attached hereto as Exhibit "C" and incorporated by reference for all purposes, for Spread Heel/Toe Weighted Golf Club, was duly and legally issued to BRENT W. BRADFORD. The '390 Patent has been assigned to Plaintiff.

10. Defendant TAYLOR MADE GOLF COMPANY, INC., manufactures, markets and sells, or has manufactured, marketed or sold among other things, the Taylor Made Putters, illustrations of which are attached hereto collectively as Exhibit "B" and incorporated by reference for all purposes.

11. Defendant TAYLOR MADE GOLF COMPANY, INC., has for an undetermined amount of time in the past and is currently infringing the afore mentioned Letters Patent by making, selling and using the Taylor Made. Defendant will continue to infringe the patented invention unless enjoined by this Court.

12. Plaintiff has placed the required statutory notice on all golf putters manufactured and sold by it under the afore mentioned Letters Patent, and has given written notice to Defendant of its infringement of the patented invention. Defendant's continued infringement of the '390 Patent constitutes willful infringement allowing Plaintiff to recover additional damages as set forth in 35 USC §284 as well as attorneys' fees as provided for in 35 USC §285.

VI.
REQUEST FOR INJUNCTIVE RELIEF

13. For the harm and damage done to Plaintiff and for the harm and damage that will continue but for the intervention of this Court, Plaintiff has no adequate remedy at law. Such damages are irreparable, are continuing and to a large degree are incalculable. Plaintiff requests that a preliminary injunction be granted enjoining Defendant, its agents, representatives, servants and employees, and all persons with knowledge of such order, from directly or indirectly manufacturing, distributing, marketing, advertising, or selling the patented invention.

WHEREFORE, Plaintiff demands judgment against Defendant and respectfully requests that this Court order the following:

- A. A preliminary and permanent injunction against further acts of infringement under 35 U.S.C. §283 of the '304 and '390 Patents by Defendant;
- B. An accounting of damages to be assessed by or under the Court's direction, and an award to Plaintiff of damages incurred by reason of Defendants acts of infringement, together with pre and post judgment interest;
- C. An increase of said damages not to exceed three times the amount found or assessed, under 35 U.S.C. §284;
- D. An award to Plaintiff of its reasonable attorneys' fees under 35 U.S.C. §285;
- E. An award to Plaintiff of its costs and expenses herein; and
- F. Judgment for such further and additional relief as the Court may deem just and proper.

Respectfully submitted,

R. WAYNE PRITCHARD, P.C.
300 E. Main, Suite 1240
El Paso, Texas 79901
Tel. (915) 533-0080
Fax (915) 533-0081

By: _____

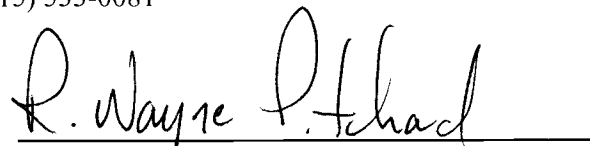

R. WAYNE PRITCHARD
State Bar No. 16340150

ATTORNEYS FOR STAGECOACH PUTTERS, LLC



US007018304B2

(12) **United States Patent**
Bradford

(10) **Patent No.:** **US 7,018,304 B2**
(45) **Date of Patent:** **Mar. 28, 2006**

- (54) **PUTTER HEAD**
- (76) Inventor: **Brent W. Bradford**, 19742 Azurefield, Newhall, CA (US) 91321
- (*) Notice: Subject to any disclaimer, the term of this patent is extended or adjusted under 35 U.S.C. 154(b) by 0 days.
- (21) Appl. No.: **10/849,002**
- (22) Filed: **May 20, 2004**
- (65) **Prior Publication Data**
US 2005/0261080 A1 Nov. 24, 2005
- (51) Int. Cl. **A63B 53/04** (2006.01)
- (52) U.S. Cl. **473/334; 473/340; 473/341; 473/336**
- (58) **Field of Classification Search** 473/334-339, 473/340-341, 328, 251-255; D21/736-746
See application file for complete search history.

5,409,219	A *	4/1995	Saksun, Sr.	473/305
5,417,429	A *	5/1995	Strand	473/251
D359,330	S *	6/1995	Channell	D21/741
5,429,356	A *	7/1995	Dingle et al.	473/251
5,533,725	A	7/1996	Reynolds, Jr.	
5,580,058	A	12/1996	Coughlin	
5,769,736	A *	6/1998	Sato	473/335
5,769,738	A	6/1998	Kershaw et al.	
5,830,078	A *	11/1998	McMahan	473/252
5,947,841	A	9/1999	Silvestro	
6,019,686	A	2/2000	Gray	
6,120,389	A	9/2000	Kruse	
6,267,689	B1	7/2001	Ambrose	
6,383,089	B1	5/2002	Bonneau	
6,435,979	B1	8/2002	Mounfield, Jr.	
6,454,663	B1	9/2002	Bakke	
6,464,599	B1	10/2002	Wolf	
6,488,595	B1 *	12/2002	Grace	473/341
6,652,390	B1 *	11/2003	Bradford	473/341
2002/0193176	A1	12/2002	Grace	
2003/0083149	A1	5/2003	Scarpa et al.	
2003/0144077	A1	7/2003	Cullen	

* cited by examiner
Primary Examiner—Sebastiano Passaniti
(74) *Attorney, Agent, or Firm*—Welsh & Flaxman

- (56) **References Cited**
U.S. PATENT DOCUMENTS
3,240,497 A 3/1966 Taylor
D223,676 S 5/1972 Meth et al.
D229,844 S * 1/1974 Pavelle D21/741
3,921,984 A * 11/1975 Winter 473/251
4,010,958 A * 3/1977 Long 473/341
4,138,117 A * 2/1979 Dalton 473/255
4,871,174 A * 10/1989 Kobayashi 473/252
5,197,737 A * 3/1993 Desbiolles et al. 473/341
5,211,401 A 5/1993 Hainey
5,294,122 A 3/1994 Longo
5,344,149 A 9/1994 Miller

(57) **ABSTRACT**
A golf putter head includes a primary body member having a striking face with a toe end and a heel end, a top surface and sole. The primary body member includes a toe wing extending back and away from the toe end of the striking face and a heel wing extending back and away from the heel end of the striking. The golf putter head also includes a first weight member extending from the toe wing and a second weight member extending from the heel wing.

16 Claims, 2 Drawing Sheets

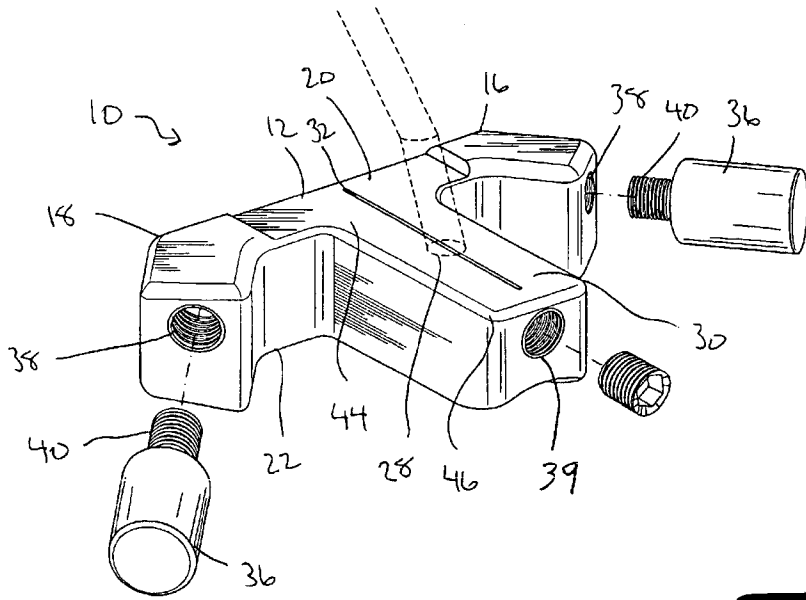

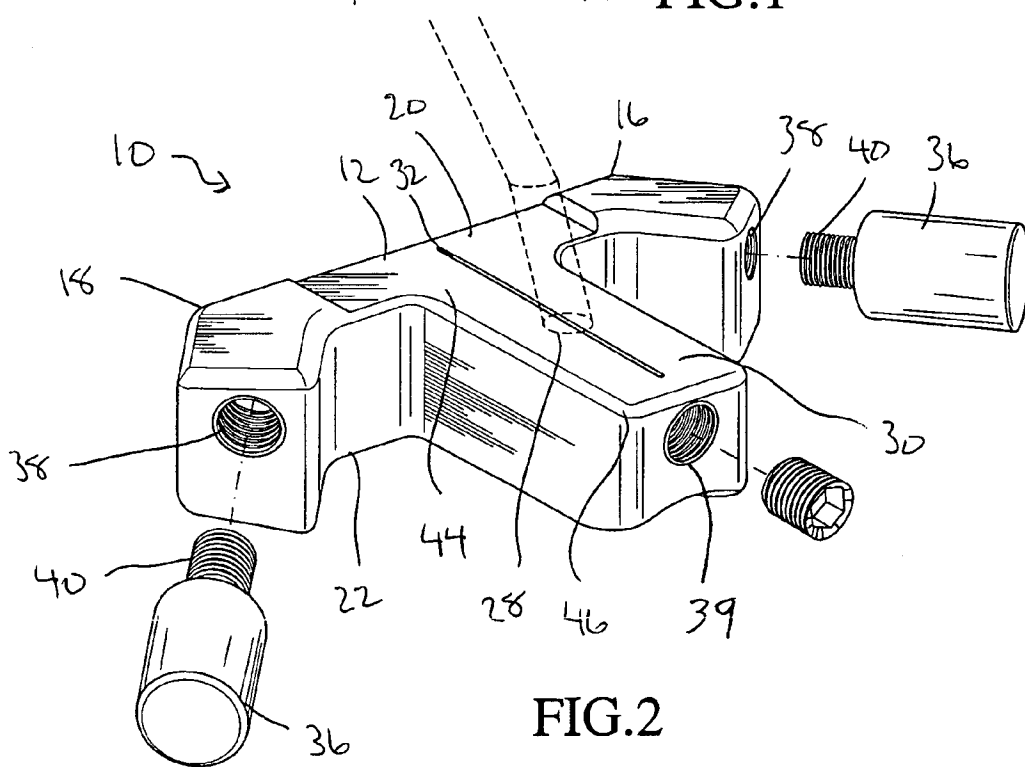
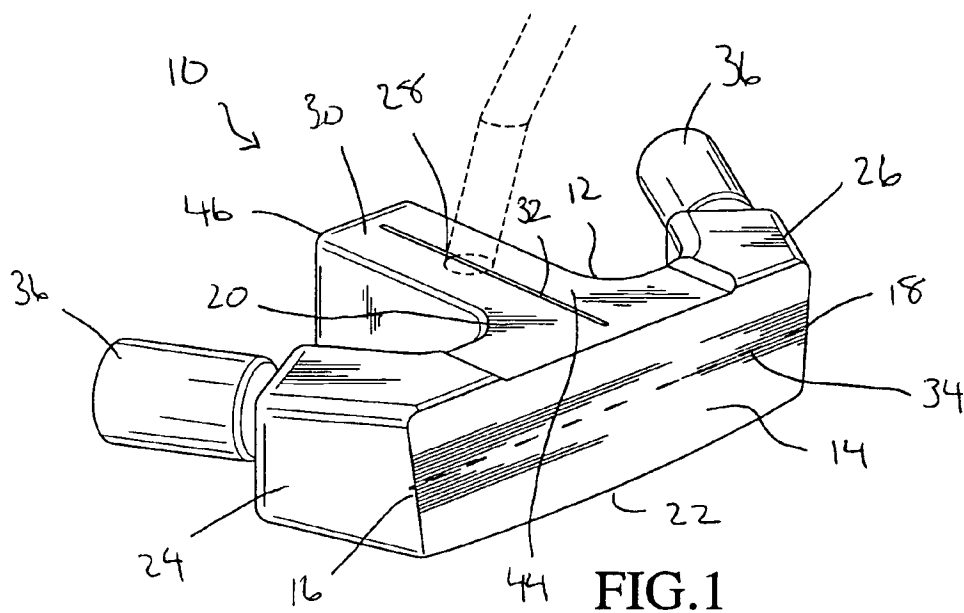

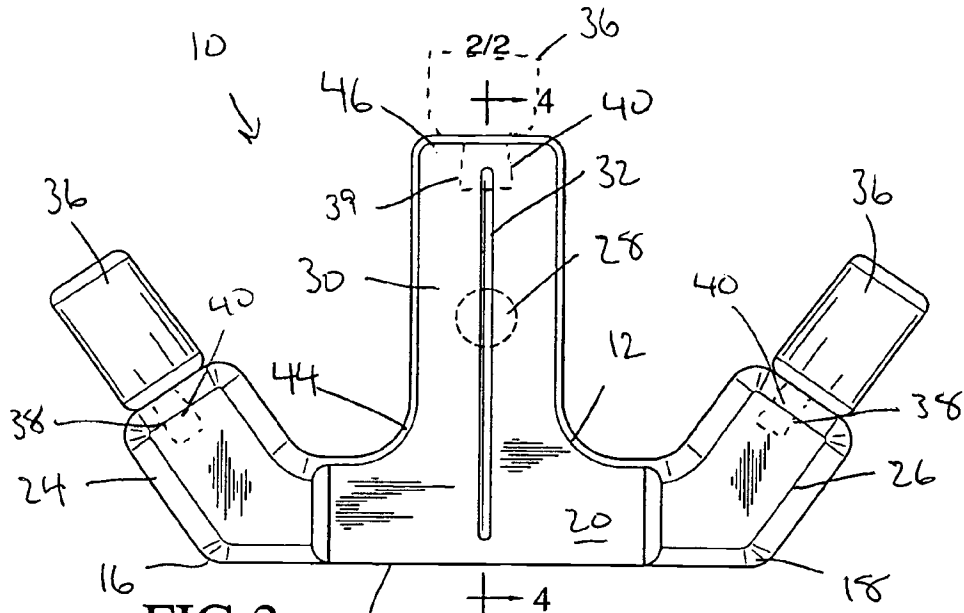

FIG. 3

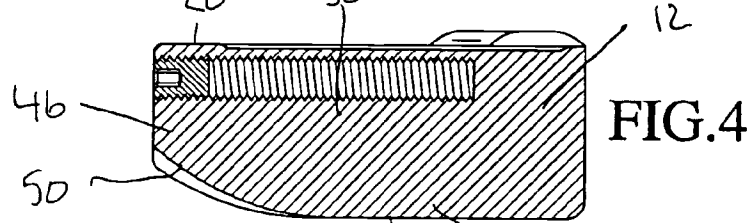

FIG. 4

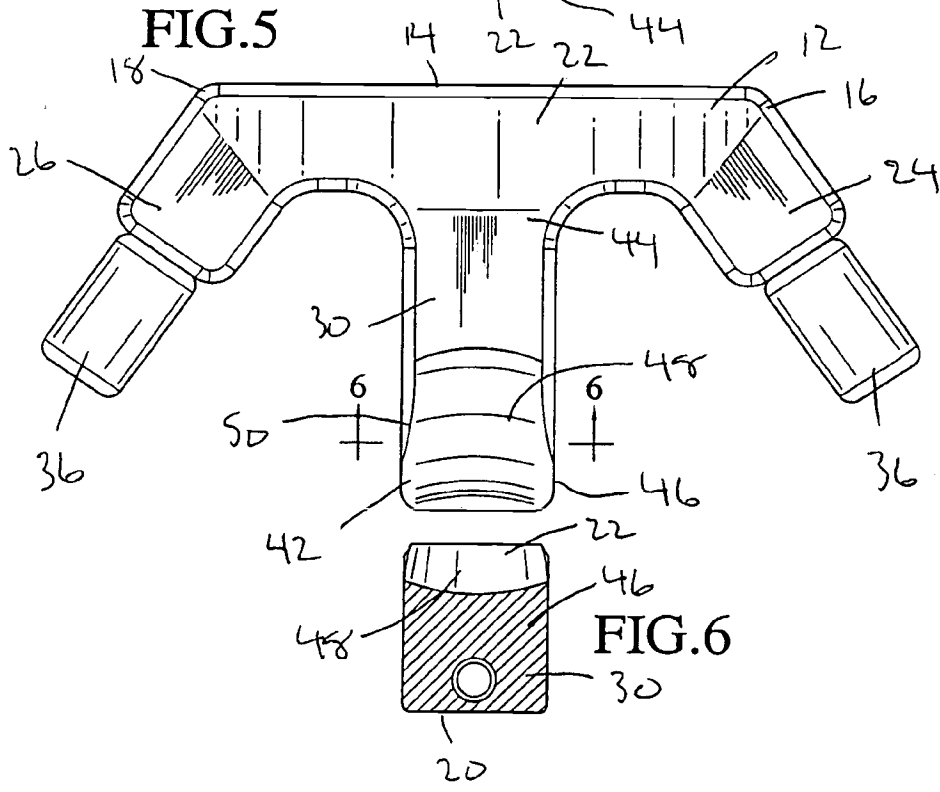

FIG. 5

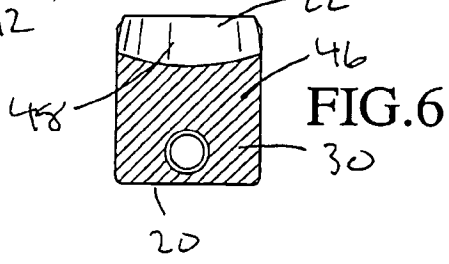

FIG. 6

US 7,018,304 B2

1

PUTTER HEAD**BACKGROUND OF THE INVENTION**

1. Field of the Invention

The invention relates to a putter head for playing the game of golf. More particularly, the invention relates to a putter head having substantial mass shifted to the heel and toe of the putter head and shifted above a horizontal center plane of the putter head.

2. Description of the Prior Art

Putters generally fall into two categories: mallet-style putter heads and blade-style putter heads. Mallet-style putter heads have a relatively large, solid head that is often semicircular in shape when viewed from above, while blade-style putter heads have a relatively narrow or blade-like head. Each type of putter includes a generally flat strike face for hitting the golf ball. Accuracy of a putt depends upon where the striking face impacts the ball, as well as on the orientation of the striking face at impact. Accuracy also depends on hitting the ball at a central area of the striking face, known in the art as the "sweet spot." Generally, control of the direction of travel of the golf ball, and the distance traveled, decreases with the increase in distance away from the sweet spot from which the ball is struck. However, the effective hitting area or sweet spot may be expanded by appropriately weighting the putter head. Weighting may also be used to improve the feel and stability of the putter head during the putting stroke.

The balance, weight and moment of inertia of a putter plays an important role in the effectiveness of the club. As such, it is desirable to increase the effective striking area while maintaining a high moment of inertia and reduce the effect of torque created from an off-center golf stroke.

Traditional de-weighting processes involve removing exterior weight from the putter head. With this design, the hosel is typically located at the end of the club head. More recently, putter head manufacturers have removed the weight from the interior of the putter head. Once the heavier material is eliminated, a solid insert of lower density material connects to the head and creates a new striking surface.

Many golf putter designs have attempted to maximize the sweet spot provided by a golf club. However, a need continues to exist for a putter head to provide a center of gravity moved rearward and upwardly relative to the striking face. The present invention provides a putter head with the majority of the putter head mass moved to the tips of the "wings." The present invention also provides a putter head with the majority of the putter head mass positioned above a horizontal center plane.

SUMMARY OF THE INVENTION

It is, therefore, an object of the present invention to provide a golf putter head including a primary body member having a striking face with a toe end and a heel end, a top surface and sole. The primary body member includes a toe wing extending back and away from the toe end of the striking face and a heel wing extending back and away from the heel end of the striking face. The golf putter head also includes a first weight member extending from the toe wing and a second weight member extending from the heel wing.

It is also an object of the present invention to provide a golf putter head wherein the primary body member further includes a central wing extending rearwardly from a center of the striking face between the heel end and the toe end, and

2

the central wing includes a first end adjacent to the striking face and a free second end extending away from the striking face.

It is another object of the present invention to provide a golf putter head wherein a third weight member extends or is continued from the second end of the central wing.

It is a further object of the present invention to provide a golf putter head wherein the first, second and third weight members are selectively coupled to the primary body member.

It is also another object of the present invention to provide a golf putter head wherein the first weight member and the second weight member are made from a material having a higher density than the primary body member.

It is yet a further object of the present invention to provide a golf putter head wherein the sole adjacent the second end of the central wing is contoured with both concave and convex surfaces.

It is also an object of the present invention to provide a golf putter head wherein sole adjacent the second end of the central wing has a radius of curvature as the central wing extends rearwardly creating a convex surface.

It is still another object of the present invention to provide a golf putter head wherein the sole adjacent the second end of the central wing has a concave surface which extends laterally across the central wing along the convex surface.

It is a further object of the present invention to provide a golf putter head wherein the first and second weight members are selectively coupled to the primary body member.

It is another object of the present invention to provide a golf putter head wherein the putter body includes a horizontal central plane, the horizontal central plane is considered to be a horizontal plane extending through the putter body and equal distance from both an uppermost surface of the upper surface of the primary body member and a lowermost surface of the sole, wherein the first and second weight members are coupled to the primary body member such that a majority of their mass is positioned above the horizontal center line.

It is also an object of the present invention to provide a golf putter head wherein at least approximately 70% of the total putter head mass is positioned above the horizontal center plane.

It is still a further object of the present invention to provide a golf putter head wherein between approximately 55% and approximately 75% of the total putter head mass is positioned above the horizontal center plane.

Other objects and advantages of the present invention will become apparent from the following detailed description when viewed in conjunction with the accompanying drawings, which set forth certain embodiments of the invention.

BRIEF DESCRIPTION OF THE DRAWINGS

FIG. 1 is a front perspective view of the putter head in accordance with the present invention.

FIG. 2 is a rear perspective view of the putter head.

FIG. 3 is a top view of the putter head.

FIG. 4 is a cross sectional view taken along the line 4-4 of FIG. 3.

FIG. 5 is a bottom view of the putter of the putter head.

FIG. 6 is a cross sectional view taken along the line 6-6 of FIG. 5.

US 7,018,304 B2

3

DESCRIPTION OF THE PREFERRED EMBODIMENT

The detailed embodiment of the present invention is disclosed herein. It should be understood, however, that the disclosed embodiment is merely exemplary of the invention, which may be embodied in various forms. Therefore, the details disclosed herein are not to be interpreted as limited, but merely as the basis for the claims and as a basis for teaching one skilled in the art how to make and/or use the invention.

With reference to FIGS. 1 to 6, a golf putter head 10 is shown. The putter head 10 includes a primary body member 12 having a "winged" configuration. The primary body member 12 of the putter head 10 includes a forward facing striking face 14 with a toe end 16 and a heel end 18, a top surface 20 and a sole 22. The primary body member 12 also includes a toe wing 24 and heel wing 26 which extend back from the respective toe end 16 and the heel end 18 of the striking face 14. The toe wing 24 and heel wing 26 extend rearwardly at an oblique angle from the striking face 14 beyond the toe end 16 and the heel end 18. As will be discussed below in greater detail, the toe and heel wings 24, 26 add weight which moves the center of gravity (CG) rearwardly from the striking face 14. The putter head 10 includes a shaft connection 28 for attachment of a traditional golf club shaft thereto.

The putter head 10 also includes a rearwardly oriented central wing 30 extending directly from the central portion of the striking face 14. The central wing 30 is aligned with the center of the putter head 10 and is, therefore, positioned equal distances from the respective toe and heel wings 24, 26. As with the toe and heel wings 24, 26, the central wing 30 moves the center of gravity rearwardly away from the striking face 14. As such, the central wing 30 represents the third weight employed in the creation of the directional, top spread heel and toe weighting.

In addition to shifting the center of gravity, the central wing 30 provides a visual indicator along the line through which the putter head 10 should move while putting a golf ball. The functionality is further enhanced by the provision of an alignment marking 32 along the top surface of the central wing 30. The alignment marking 32 is oriented perpendicularly to the striking face 14 and is positioned at the center of the striking face 14 where one should strike a golf ball while putting.

In accordance with a preferred embodiment of the present invention, the primary body member 12 is made of aluminum. However, and as those skilled in the art will certainly appreciate, other materials may be used without departing from the spirit of the present invention.

In addition to shifting mass rearwardly in an effort to move the center of gravity rearwardly to enhance the functionality of the present putter head 10, the mass of the putter head 10 is shifted above the horizontal center plane 34 of the primary body member 12. The horizontal center plane 34 of the putter head 10 is considered to be a horizontal plane extending through the putter head 10 as it lies on a putting surface. The horizontal center plane 34 is positioned equal distances from both the uppermost surface of the primary body member 12 and lowermost surface of the primary body member 12.

By shifting the weighting above the horizontal center plane 34 of the primary body member 12, the force applied by the putter head 10 upon striking a golf ball promotes greater and more immediate top spin when a golf ball is struck. This is achieved by increasing the angular momentum

4

imparted to the struck golf ball. By shifting the mass of the putter head 10 upward, and thereby lifting the center of gravity upward, the center of gravity will be at or above the center line of the struck golf ball, thereby avoiding undesirable lifting or rising of the golf ball upon impact.

This shift in weight is achieved by securing high density weight members to the free ends of the toe and heel wings 24, 26 at a position such that the majority of the weight members 36 are above the horizontal center plane 34 of the primary body member 12. In accordance with a preferred embodiment of the present invention, the weight members 36 are formed of a tungsten/copper composite or pure tungsten. However, those skilled in the art will appreciate that the weight members may be formed from a variety of other high density materials without departing from the spirit of the present invention.

In accordance with a preferred embodiment of the present invention, each of the weight members 36 includes a central longitudinal axis and the axis, when the respective weighting members 36 are secured to the toe and heel wings, extends through the primary body member 12 at a position between the horizontal center plane 34 and the uppermost surface of the primary body member 12. In this way, the majority of the weight attributed to the weight members 36 is positioned above the horizontal center plane 34, shifting the majority of the mass of the putter head 10 above the horizontal center plane 34.

The versatility of the present putter head 10 is further enhanced by providing the weight members 36 such that they are selectively removable from the toe and heel wings 24, 26 of the primary body member 12. More specifically, each of the toe and heel wings 24, 26 are formed with threaded recesses 38 shaped and dimensioned for receipt of a threaded post 40 extending from each of the weight members 36. As such, the weight members 36 may be selectively screwed into and out of the threaded recesses 38 formed in each of the wings 24, 26 for attachment of various weight members 36 (of various weights) depending upon the needs and desires of individual golfers.

Although the weight members 36 are disclosed as being cylindrical bodies attached to the free ends of the toe and heel wings 24, 26 using a threaded attachment mechanism, other shapes, attachment structures and orientations may be employed without departing from the spirit of the present invention.

The second end 46 of the central wing 30 is similarly provided with a threaded recess 39 shaped and dimensioned for receipt of the threaded post 40 extending from the weight members 36. A such, greater versatility is provided as the weight members may be selectively secured in any combination to the three wings.

In accordance with a preferred embodiment of the present invention, the mass of the putter head 10 is shifted such that at least approximately 55% to 75% of the putter head mass is located above the horizontal center plane 34. More preferably, at least 70% of the total putter head mass is positioned above the horizontal center plane 34.

The putter head 10 is further provided with a unique sole structure 22 helping the golfer move the putter head 10 along the ground as he or she prepares to stroke a putt. In particular, the sole 22 of the putter head 10 is curved as it extends from the toe to the heel with the lowermost point of the sole 22 being substantially aligned with a central position between the heel end 18 and toe end 16 of the striking face 14. In particular, the sole has a radius of curvature of between approximately 80 to 160 inches and, more preferably, approximately 120 inches.

US 7,018,304 B2

5

In addition, the distal sole surface 42 of the central wing 30 is radiused to improved the interaction between the sole 22 and the putting surface as a ball is stroked. More specifically, the central wing 30 includes a first end 44 adjacent to the striking face 14 and a free second end 46 extending away from the striking face 14. The second end 46 is contoured to enhance performance of the club head 10 by providing both concave and convex surfaces 48, 50. More particularly, the second end 46 of the central wing 30 has a radius of curvature as the central wing 30 extends rearwardly creating a convex surface 50. The radius of curvature for this convex surface 50 is preferably sufficient to release the second end from undesirable contact with the fringe surrounding a putting green.

With regard to the concave surface 48, it extends laterally across the central wing 30 along the convex surface 50 extending from front to back along the second end 46. The concave radius of curvature for this concave surface 48 is preferably sufficient to minimize undesirable contact of the second end 46 with the putting surface.

The radius of curvature of each of the convex and concave surfaces generally does not extend more than midway between the top surface and the sole.

In general, the specific weighting of the putter head optimizes performance. The combination of the toe and heel wings, as well as the weight members extending therefrom and the central wing, provide a tri-weighting system with extreme heel and toe weighting. For example, the wings and weight members allow the mass to be moved much further back and beyond the striking face. Thus, the center of gravity can be moved much further back than the typical "blade" or "mallet" putter. Further, the provision of a central wing extending rearwardly from the striking face moves the center of gravity rearwardly in a desirable manner, as well as providing a weight receiving recess so that a weight can be placed at the extreme end thereof or adjusted to fill the entire cavity above the horizontal plane if desired.

Not only does this design provide for extreme heel and toe weighting, but it locates large masses outside the striking face edges and on opposite sides of shaft connection. With this design a higher moment of inertia for club head twisting is created, reducing the effects of torque from an off-center putt. Thus the force of a ball struck at off-center point will be minimal compared to the force required to start the head twisting. That is, the force generated by striking a ball is minimal when compared to the weight displaced from the central striking surface as a result of the weighted wings which shift the weight of the putter head toward the heel and toe of the club. These weighted wings generate a substantial moment which compensates, and covers up, any undesirable moments generated when a golf ball is struck off center by an individual putting.

In addition to shifting mass toward the toe and heel of the putter head, mass is shifted upwardly above the horizontal center plane of the putter. As the horizontal central plane is generally designed to correspond to the center of a golf ball being struck by the present putter, the majority of putter head weight is concentrated above the center of the ball, causing the ball to immediately begin rolling upon impact as the higher weight encourages rolling of the golf ball in conjunction with the forward motion.

It will certainly be understood by those of ordinary skill in the art the dimensions of the putter head may be varied depending upon the particular swing characteristics desired for the putter head. For example, the wings may extend back and away from the center of gravity at various angles.

6

The improved accuracy is a result of the total head design features. The high density of the weight members adds substantial weight along the toe and heel wings so that a majority of the weight resides in the tips of the toe and heel wings. As discussed above, the higher positioning of the putter head mass relative to the horizontal center plane enhances forward rotation of a golf ball upon impact. The total head design features and the mass positioning produce a straighter, more reliable putt. When a ball is not struck squarely, the club will tend to 'twist' and the ball will generally not travel in a straight path. The club of the present invention has a higher moment of inertia in the torque or twist plane of the club head, helping to direct improperly struck golf balls toward a desired path. The heel and toe weighting creates a higher moment of inertia, reducing the effects of torque from an off-center putt. In fact, each weight member weighs more than a golf ball. This directly affects the accuracy of the shot and is better for performance.

While the preferred embodiments have been shown and described, it will be understood that there is no intent to limit the invention by such disclosure, but rather, is intended to cover all modifications and alternate constructions falling within the spirit and scope of the invention as defined in the appended claims.

The invention of claimed is:

1. A golf putter head, comprising:

- a primary body member having a striking face with a toe end and a heel end, a top surface and sole;
- the primary body member including a toe wing extending back and away from the toe end of the striking face at an oblique angle beyond the toe end;
- the primary body member also including a heel wing extending back and away from the heel end of the striking at an oblique angle beyond the heel end;
- a first weight member extending from the toe wing and a second weight member extending from the heel wing.

2. The golf putter head according to claim 1, wherein the primary body member further includes a central wing extending rearwardly from a center of the striking face between the heel end and the toe end, and the central wing includes a first end adjacent to the striking face and a free second end extending away from the striking face.

3. The golf putter head according to claim 2, wherein a third weight member extends from the second end of the central wing.

4. The golf putter head according to claim 3, wherein the first, second and third weight members are selectively coupled to the primary body member.

5. The golf putter head according to claim 2, wherein the first weight member and the second weight member are made from a material having a higher density than the primary body member.

6. The golf putter head according to claim 1, wherein the first and second weight members are selectively coupled to the primary body member.

7. The golf putter head according to claim 1, wherein the putter body includes a horizontal central plane, the horizontal central plane is considered to be a horizontal plane extending through the putter body and equal distance from both an uppermost surface of the upper surface of the primary body member and a lowermost surface of the sole, wherein the first and second weight members are coupled to the primary body member such that a majority of their mass is positioned above the horizontal center line.

8. The golf putter head according to claim 1, wherein the putter body includes a horizontal central plane, the horizontal central plane is considered to be a horizontal plane

US 7,018,304 B2

7

extending through the putter body and equal distance from both an uppermost surface of the upper surface of the primary body member and a lowermost surface of the sole, and a majority of their mass is positioned above the horizontal center line.

9. The golf putter head according to claim 6, wherein approximately at least 70% of the total putter head mass is positioned above the horizontal center plane.

10. The golf putter head according to claim 9, wherein between approximately 55% and approximately 75% of the total putter head mass is positioned above the horizontal center plane.

11. A golf putter head, comprising:
a primary body member having a striking face with a toe end and a heel end, a top surface and sole;
the primary body member including a toe wing extending back and away from the toe end of the striking face;
the primary body member also including a heel wing extending back and away from the heel end of the striking;
a first weight member extending from the toe wing and a second weight member extending from the heel wing;
the primary body member also includes a central wing extending rearwardly from a center of the striking face between the heel end and the toe end, and the central wing includes a first end adjacent to the striking face and a free second end extending away from the striking face; and
wherein the sole adjacent the second end of the central wing is contoured with both concave and convex surfaces.

12. The golf putter head according to claim 11, wherein sole adjacent the second end of the central wing has a radius of curvature as the central wing extends rearwardly creating a convex surface.

8

13. The golf putter head according to claim 12, wherein the sole adjacent the second end of the central wing has a concave surface which extends laterally across the central wing along the convex surface.

14. A golf putter head, comprising:
a primary body member having a striking face with a toe end and a heel end, a top surface and sole;
the putter body further including a central wing extending rearwardly from a center of the striking face between the heel end and the toe end, wherein the central wing includes a first end adjacent to the striking face and a free second end extending away from the striking face, and the sole adjacent the second end is contoured with both a concave surface with a radius of curvature as viewed from a rear of the putter head and a convex surfaces with a radius of curvature as viewed in cross-section through said central wing from a toe end; the radius of curvature of each of the convex and the concave surfaces generally not extending more than midway between the top surface and the sole.

15. The golf putter head according to claim 14, wherein the second end of the central wing has a radius of curvature as the central wing extends rearwardly creating a convex surface.

16. The golf putter head according to claim 15, wherein the second end of the central wing has a concave surface which extends laterally across the central wing along the convex surface.

* * * * *

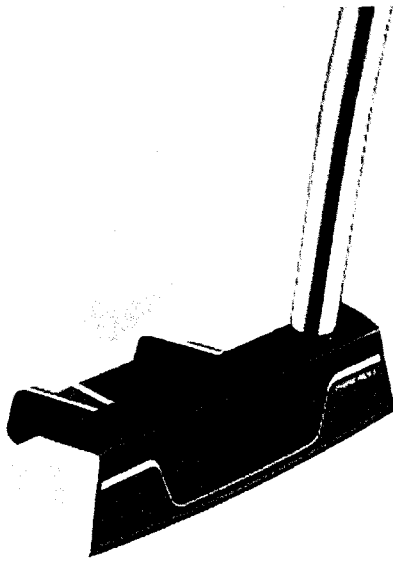

PENGAD-Beynon, N. J
**PLAINTIFF'S
EXHIBIT**
'B'



US006652390B2

(12) **United States Patent**
Bradford

(10) **Patent No.:** **US 6,652,390 B2**
(45) **Date of Patent:** **Nov. 25, 2003**

(54) **SPREAD HEEL/TOE WEIGHTED GOLF CLUB**

D422,041 S 3/2000 Bradford D21/736
6,238,302 B1 * 5/2001 Helmstetter et al. 473/340
6,273,831 B1 * 8/2001 Dewanjee 273/DIG. 8

(76) **Inventor:** **Brent W. Bradford**, 18102 Flynn Dr.
#4601, Canyon Country, CA (US)
91351

* cited by examiner

Primary Examiner—Paul T. Sewell
Assistant Examiner—Tom Duong
(74) *Attorney, Agent, or Firm*—Welsh & Flaxman LLC

(*) **Notice:** Subject to any disclaimer, the term of this patent is extended or adjusted under 35 U.S.C. 154(b) by 0 days.

(57) **ABSTRACT**

The present invention provides an extreme heel and toe weighted golf putter head wherein the weight is spread along the length of the head and outside of the effective hitting area. The putter includes a head having a front surface shaped and dimensioned for contacting a golf ball and a back surface shaped and dimensioned for placing the weight of the club at a relatively large distance from the striking face. The back surface has a toe wing, a shaft connection, and a heel wing, with the wings angling back beyond and away from the centered shaft connection on either side. More specifically, the putter includes a toe section having a toe wing extending back and away from the striking face toward the toe section of the putter. The heel section having a heel wing extending back and away from the striking face toward the heel section of the putter. A recess formed in the body, the toe wing, and the heel wing and a light weight insert material filling the recess formed in the body, toe wing and heel wing.

(21) **Appl. No.:** **09/904,656**

(22) **Filed:** **Jul. 16, 2001**

(65) **Prior Publication Data**

US 2003/0013546 A1 Jan. 16, 2003

(51) **Int. Cl.**⁷ **A63B 53/04**

(52) **U.S. Cl.** **473/341; 473/340; 473/342**

(58) **Field of Search** **473/340, 334, 473/335, 341, 342, 346, 347, 349, 350**

(56) **References Cited**

U.S. PATENT DOCUMENTS

- 3,966,210 A * 6/1976 Rozmus 473/341
- 5,605,510 A * 2/1997 Schmidt et al. 473/251
- D381,382 S 7/1997 Fenton, Jr. D21/217
- D399,274 S 10/1998 Bradford D21/217
- 5,842,935 A * 12/1998 Nelson 473/341
- 5,951,412 A * 9/1999 Rose et al. 473/340

15 Claims, 6 Drawing Sheets

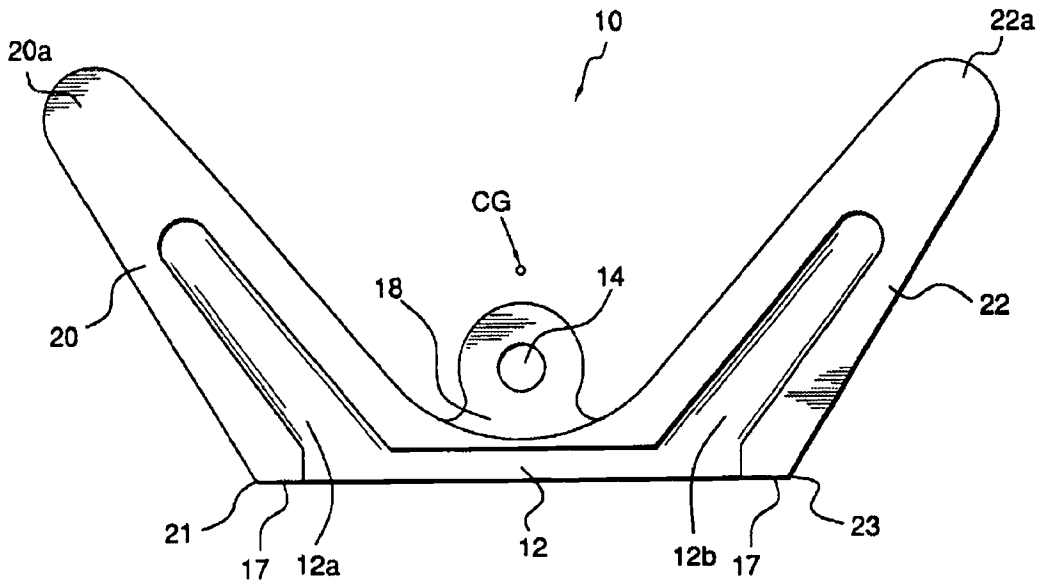

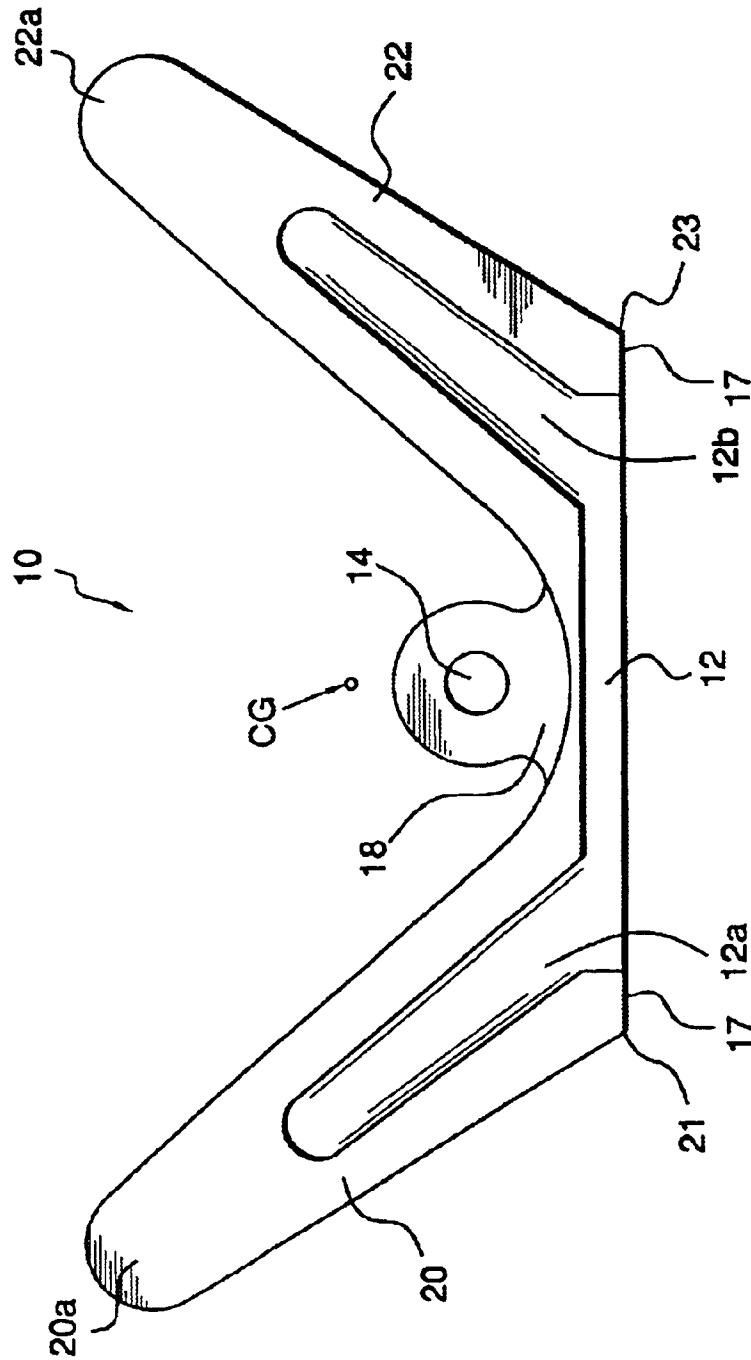
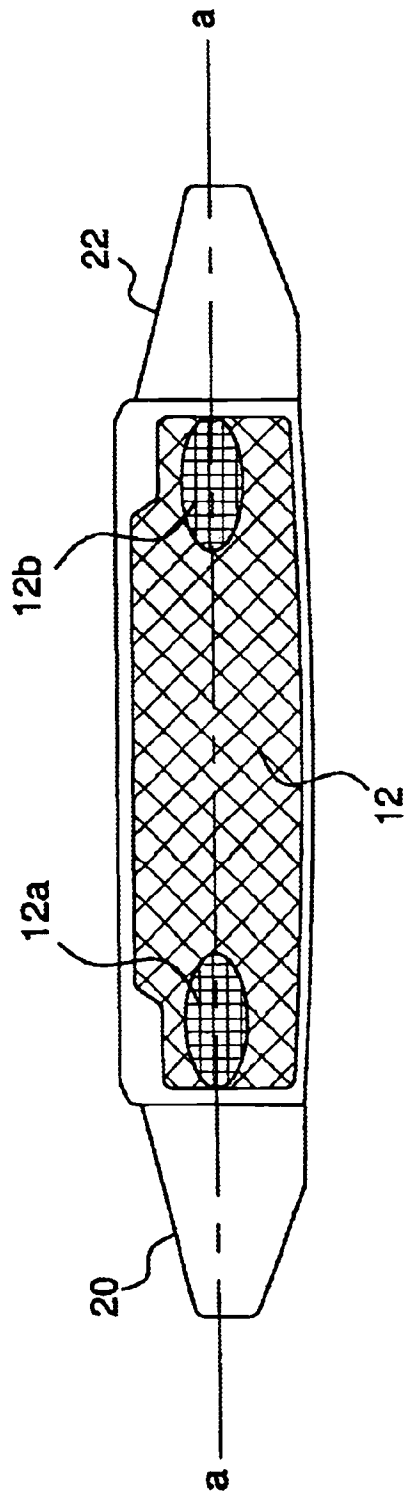

FIG. 1

FIG. 2



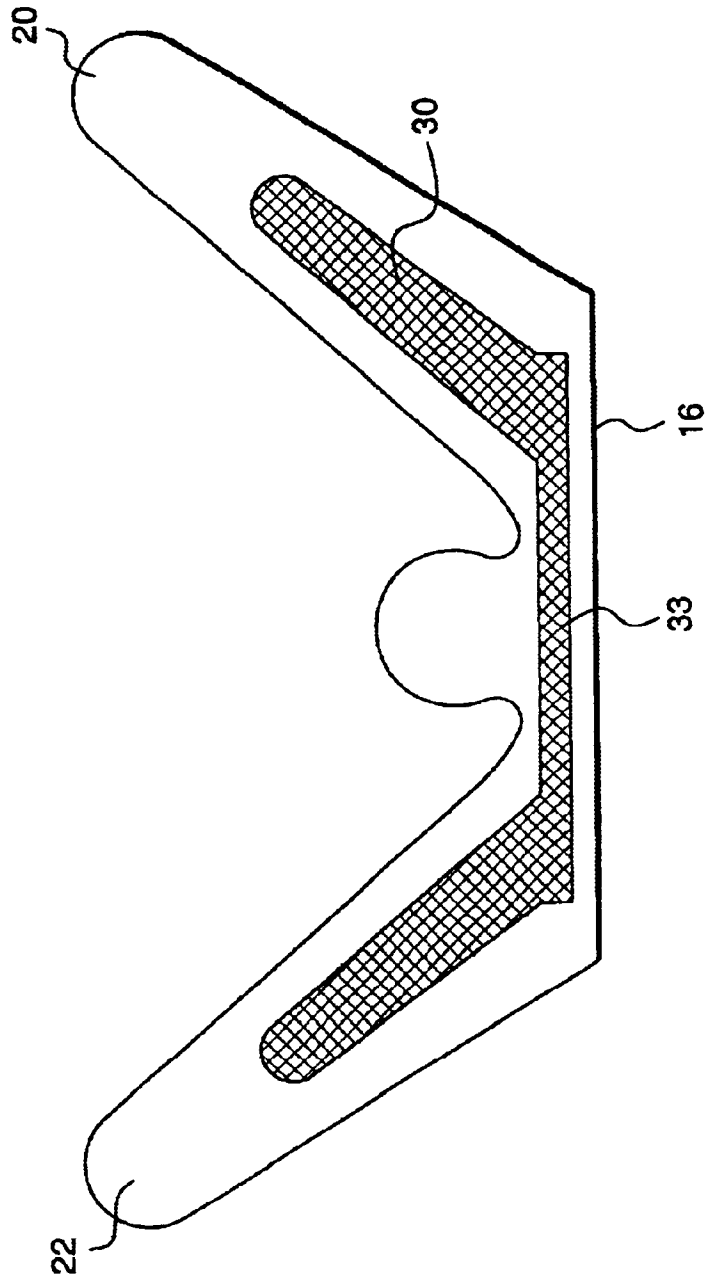

FIG. 3

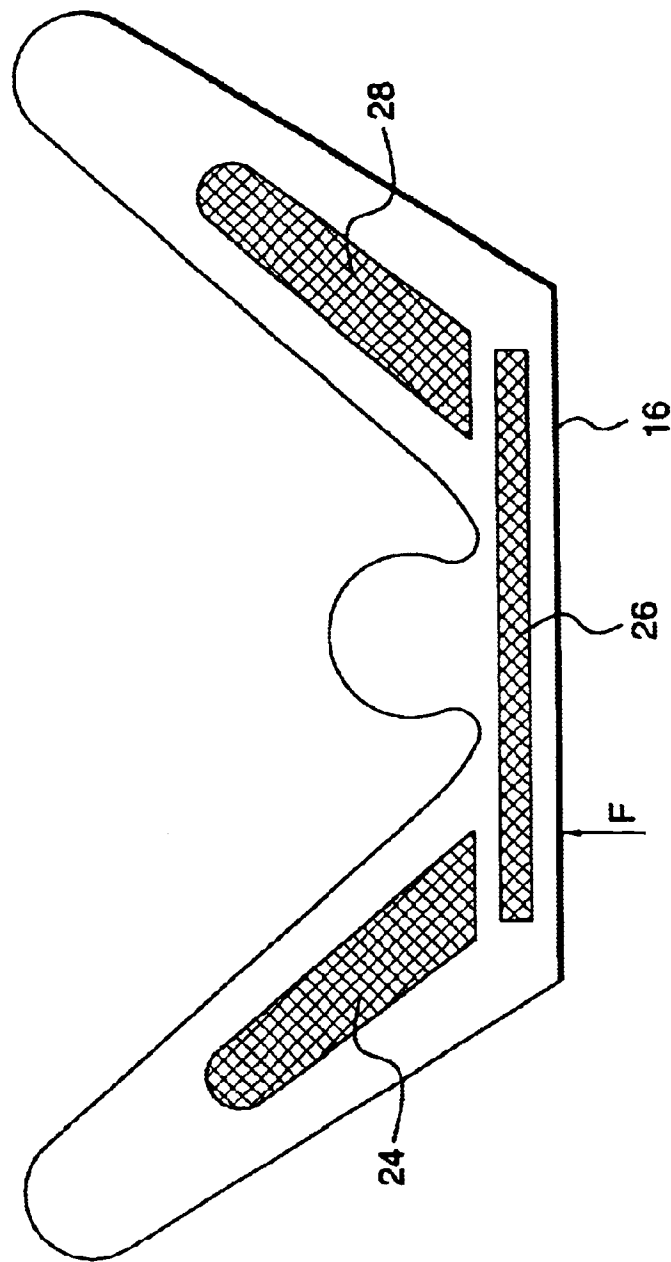

FIG. 4

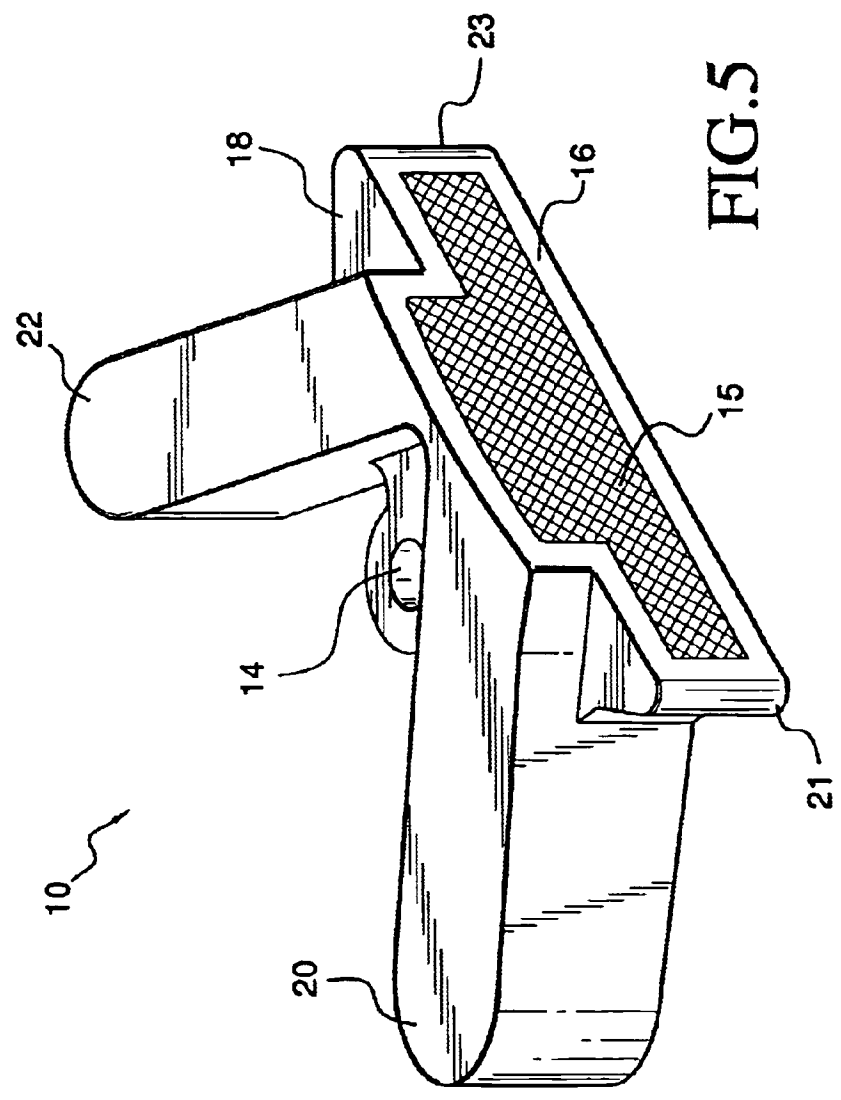

FIG. 5

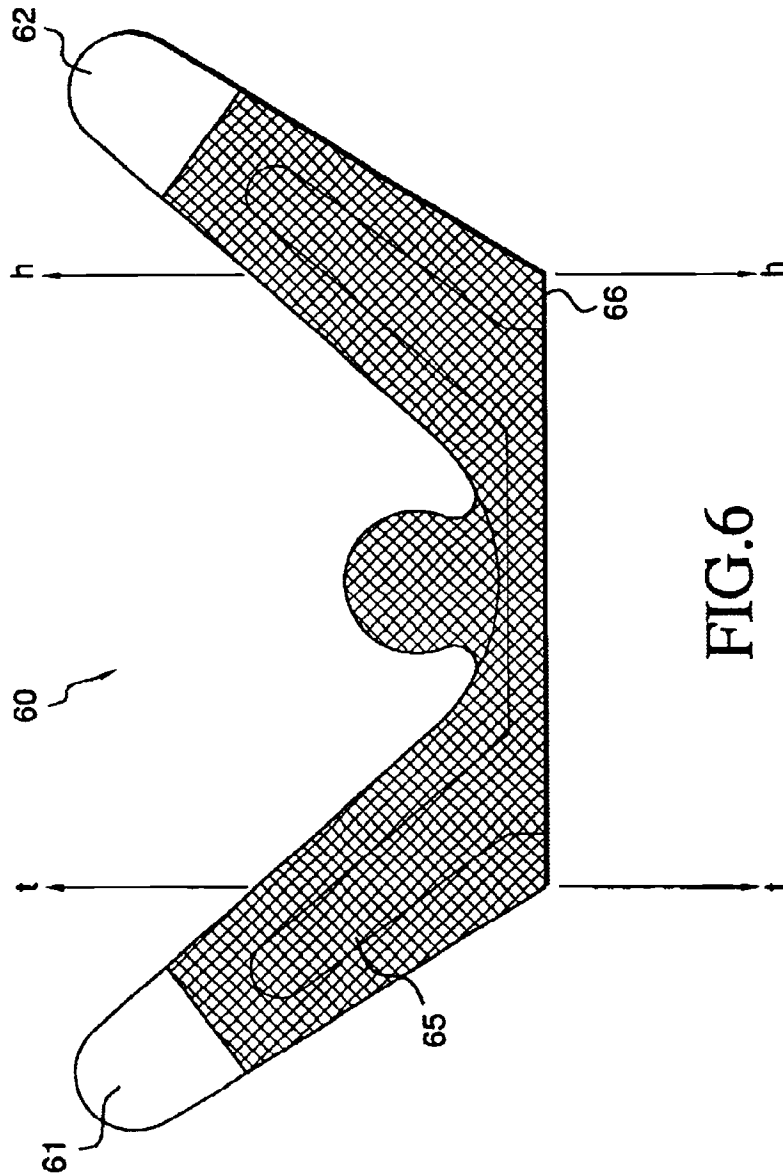

FIG. 6

US 6,652,390 B2

1

SPREAD HEEL/TOE WEIGHTED GOLF CLUB

BACKGROUND OF THE INVENTION

1. Field of the Invention

The invention relates to an extreme heel and toe weighted golf club. More particularly, the invention relates to a putter where material has been removed from the face surface and interior of the club head down along two rearwardly angled wings, to shift the club head weighting off the face and to the extreme heel and toe locations. Therefore, a the majority of the mass of the club head is located at the tips of the putter wings which are located behind and laterally spaced from the striking area of the club head.

2. Description of the Prior Art

Generally, putters fall into two categories of clubs mallet-style and blade-style. The mallet-style putter has a relatively large, solid head that is often semi-circular in shape when viewed from above, while the blade-style putter has a relatively narrow or blade-like head. Each type of putter includes a generally flat strike face for hitting the golf ball and accuracy of the putt depends upon where the strike face impacts the ball, as well as on the orientation of the strike face at impact. Accuracy also depends on hitting the ball at a central area of the strike face, known in the art as the "sweet spot". Generally, control of the direction of travel of the golf ball, and the distance traveled, decreases with the increase in distance away from the sweet spot from which the ball is struck. However, the effective hitting area or sweet spot may be expanded by appropriately weighting the putter head. Weighting may also be used to improve the feel and stability of the putter head during the putting stroke.

The balance, weight, and moment of inertia of a putter plays an important role in the effectiveness of the club. As such Applicant's design goal is to increase the effective striking area while maintaining a high moment of inertia and reduce the effect of torque created from an off-center golf stroke.

The traditional de-weighting process involved removing exterior weight. With this design, the hosel is typically located at the end of the club head. More recently, putter head manufacturers have removed the weight from the interior of the putter head. Once the heavier material is eliminated, a solid insert of lower density material connects to the head and creates a new striking surface.

Many golf putter designs have attempted to maximize the sweet spot provided by a golf club. However, a need continues to exist for a putter head to provide a center of gravity moved rearward from the striking face and extreme heel and toe spread weighting while not reducing the overall feel of the putter. The present invention provides a putter head with the majority of the putter head mass moved to the tips of the "wings". The face surface and interior of the wings are tooled to create voids and reduce weight. An insert material is poured into the voids resulting in extreme heel and toe weighting and a center of gravity far removed from the striking face.

SUMMARY OF THE INVENTION

It is, therefore, an object of the present invention to provide an extreme heel and toe weighted golf putter head wherein the weight is spread along the length of the head and outside of the effective hitting area. The putter includes a head having a front surface shaped and dimensioned for

2

contacting a golf ball and a back surface shaped and dimensioned for placing the weight of the club at a relatively large distance from the striking face. The back surface has a toe wing, a shaft connection, and a heel wing so that a top view is generally appears "W"-shaped, with the wings angling back beyond and away from the centered shaft connection on either side. More specifically, the putter includes a body having a heel section, toe section, upper surface, lower surface and striking face. The toe section having a toe wing extending back and away from the striking face toward the toe section of the putter. The heel section having a heel wing extending back and away from the striking face toward the heel section of the putter. A recess formed in the body, the toe wing, and the heel wing and a shaft connection in the body located between the wings. An insert material filling the recess formed in the body, toe wing and heel wing forming a flat soft feel putter striking face.

It is also an object of the present invention to remove a portion of the heavy interior material from the striking surface and/or interior of the wings to create voids.

It is also an object of the present invention to fill the putter head voids with a lighter weight material, such as an elastomer co-polymer.

It is a further object of the present invention to provide a putter head wherein the creation of spread extreme heel and toe weighting creates a shift in the center of gravity and a greater resistance to club head twisting by creating a larger moment of inertia to torque.

It is also an object of the present invention to create a de-weighted putter head that is more efficient and playable with better balance.

Other objects and advantages of the present invention will become apparent from the following detailed description when viewed in conjunction with the accompanying drawings, which set forth certain embodiments of the invention.

BRIEF DESCRIPTION OF THE DRAWINGS

FIG. 1 is a cross-section taken along line a—a in FIG. 2 highlighting the locations where an insert will be located.

FIGS. 2 is a face view, facing the striking surface, highlighting the locations where heavy material will be removed, including cavities running down the wings.

FIGS. 3 and 4 are sole views illustrating embodiments wherein the striking surface is left intact and the insert material is added through the putter head sole.

FIG. 5 is a perspective view of the club head of the preferred embodiment.

FIG. 6 is a top view of another embodiment wherein the extreme the extreme wing tips are made from a heavier material.

DESCRIPTION OF THE PREFERRED EMBODIMENTS

The detailed embodiments of the present invention are disclosed herein. It should be understood, however, that the disclosed embodiments are merely exemplary of the invention, which may be embodied in various forms. Therefore, the details disclosed herein are not to be interpreted as limited, but merely as the basis for the claims and as a basis for teaching one skilled in the art how to make and/or use the invention.

With reference to FIGS. 1 and 5, a golf putter head 10 is shown having a body 18 with a recess 12 defined therein.

US 6,652,390 B2

3

The golf club head **10** is of a specific "winged" configuration and includes a toe wing **20** and heel wing **22** which extend back from a striking face **16**. The wings **20, 22** also extend laterally on an angle from the body **18** beyond the striking face toe edge **21** and striking face heel edge **23**. These wings add weight which moves the center of gravity (CG) rearwardly from the striking face **16**. The putter head **10** includes a shaft connection **14** for attachment of a golf club shaft thereto.

The recess is **12** shaped to remove a large portion of the interior of the body **18** and a portion of each wing **20, 22**. The recess **12** is preferably filled with a pour-in insert **15** of a lighter weight material so as to be planar with the metal club face **17** to form a flat soft to the touch striking face **16**.

The insert **15** is preferably a non-metallic material but could be any light weight material including various light weight metals. However, the preferred material is an elastomeric material, such as a polyurethane.

The putter head **10** may be made from any material commonly used in the manufacture of putter heads. For example, the putter head may be a metal, or an alloy of various metals. The preferred material is brass.

FIG. 2 is a face view further illustrating the amount of material removed to create the recess **12** in the striking face **16**. Voids **12a** and **12b** continuous with recess **12** are created in the interior of the wings **20,22** but do not extend the whole length of the wings **20,22**. Thus the mass at the tip sections is much greater than the rest of the wings since the voids will be filled with a much lighter insert **15**. Thus the solid metal wing tips weigh more than the striking face portion of the club head. The continuous recess also provides another extremely beneficial feature in that it functions to aid in securing the insert **15** to the club body. Due to the angle of the wings and recess formed therein, insert **15** includes angled legs extending down the wings **20, 22** which prevented it from easily being removed.

FIGS. 3 and 4 are sole views of an additional embodiment wherein the striking face **16** is left intact and the recess is formed from the sole upward. In FIG. 3 a recess **30** forms a continuous void extending down both wings **20, 22** and is connected by a channel **33** behind the striking face **16**. The material is removed directly through the sole.

In FIG. 4, the putter head is formed with three separate voids **24, 26, 28**. The striking face **16** is left intact and the insert material is poured into each void through the sole.

In FIG. 6, a putter head made from two different materials is shown. The body **65** from a lighter material such as aluminum and the wing tips **61, 62** from a heavier material such as tungsten. This embodiment also results in spread heel/toe weighting with at least twenty-five percent of the club head weight being located outside the effective hitting area bound by lines t—t and h—h. These lines are at the edge of the striking face toe and heel, respectively. Again, by spreading the weight outside of the effective hitting area the sweet spot of the club face is increased. That is off-center contact will not cause club head twisting, because the force need to create a moment about the center of gravity is greater than that caused by off-center ball contact. The spreading of the weight aids in resisting any torque caused by an off-center contact force. The movement of the weight rearward from the striking face also moves the center of gravity back as discussed above which also functions to aid in preventing club head twist in cooperation with the spread heel/toe weighting.

In general, the specific weighting of the putter head **10** is designed to provide an extreme heel and toe weighting. For

4

example, the wings **20, 22** allow the mass to be moved much further back and beyond the striking face. Thus, the center of gravity can be moved much further back than the typical "blade" or "mallet" putter. Further, removing the interior mass of the wings, except for at the tips, increases this attribute significantly in comparison to other designs.

Not only does this design provide for extreme heel and toe weighting, but it locates large masses **20a, 22a** outside the striking face edges **21** and **23** and on opposite sides of shaft connection **14**. This type of weight resembles a barbell. With this design a higher moment of inertia for club head twisting is created, reducing the effects of torque from an off-center putt. Thus the force **F**, shown in FIG. 4, of a ball struck at off-center point will be minimal compared to the force required start the head twisting. That is, the force generated by striking a ball is minimal when compared to the weight displaced from the central striking surface as a result of the weighted wings which shift the weight of the putter head toward the heel and toe of the club. These weighted wings generate a substantial moment which compensates, and covers up, any undesirable moments generated when a golf ball is struck off center by an individual putting.

It will certainly be understood by those of ordinary skill in the art that the dimensions of the putter head **10** may be varied depending upon the particular swing characteristics desired for the putter head **10**. For example, with reference to FIG. 1, and in accordance with the preferred embodiment of the present invention, the wings **20, 22** may extend back and away from the center of gravity at various angles.

The improved accuracy is a result of the total head design features. The weight of the metal material exceeds the insert material so that a majority of the weight resides in the tips of the wings **20, 22**. The total head design features and the mass positioning produce a straighter, more reliable putt. When a ball is not struck squarely, the club will tend to 'twist' and the ball will generally not travel in a straight path. The club of the present invention has a higher moment of inertia in the torque or twist plane of the club head helping to direct improperly struck golf balls toward a desired path. The heel and toe weighting creates a higher moment of inertia, reducing the effects of torque from an off-center putt. This directly effects the accuracy of the shot and is better for performance.

Despite the recess **12** created for the insert, the putter head **10** provides excellent balance permitting balls to be struck consistently, even off-center. In fact, by altering the weight distribution, head configuration and insert material, the center of gravity and the total mass within the golf club head can be ideally defined.

While the preferred embodiments have been shown and described, it will be understood that there is no intent to limit the invention by such disclosure, but rather, is intended to cover all modifications and alternate constructions falling within the spirit and scope of the invention as defined in the appended claims.

What is claimed is:

1. A putter type golf club head including a body having a heel section, toe section, upper surface, lower surface and striking face terminating with toe and heel edges, further comprising:

- a toe wing extending back and away from said striking face toward the toe section of said head, wherein the wing extends laterally beyond the striking face toe edge;
- a heel wing extending back and away from said striking face toward the heel section of said head, wherein the wing extends laterally beyond the striking face heel edge;

US 6,652,390 B2

5

a recess formed in the body, the toe wing, and the heel wing and extending from said body into a portion of each wing beyond the extent of the edges of the striking face, wherein the recess reduces the weight of the body and a portion of each wing; and

a shaft connection located between said wings.

2. A golf putter head according to claim 1, wherein an insert material fills the entire recess and is planar with the striking face.

3. A golf putter head according to claim 1, wherein an insert material fills the entire recess and is located behind the striking face of said head.

4. A golf putter head according to claim 1, wherein the recess is filled with a light weight insert material.

5. A golf putter head according to claim 1, wherein the wings are weighted beyond the extent of the edges of the striking face, thereby spreading the putter head weight.

6. A golf putter head according to claim 5, wherein the weight of the wings extending laterally beyond the extent of the edges of the striking face is greater than the weight of the body.

7. A golf putter head according to claim 2, wherein the insert is one continuous piece of poured elastomeric material.

8. A golf putter head according to claim 3, wherein the insert is inserted into the head through the lower surface.

9. A putter type golf club head including a body having a heel section, toe section, upper surface, lower surface and striking face terminating with toe and heel lateral edges, further comprising:

a toe wing extending back and away from said striking face toward the toe section of said head, wherein the wing extends laterally beyond the striking face toe lateral edge;

a heel wing extending back and away from said striking face toward the heel section of said head, wherein the wing extends laterally beyond the striking face heel lateral edge;

6

a shaft connection located between said wings; spread weighting of the head such that greater than twenty-five percent of the total head weight extends beyond the lateral edges of the striking face; and

wherein a first portion of the toe and heel wings approximate the tips thereof are made from a first material and the remainder of the wings are made from a second lighter material.

10. A golf putter head according to claim 9, wherein the first material is tungsten.

11. A golf putter head according to claim 9, wherein the second lighter material is aluminum.

12. A golf putter head according to claim 10, wherein the second lighter material is aluminum.

13. A putter type golf club head including a body having a heel section, toe section, upper surface, lower surface and striking face terminating with toe and heel lateral edges, further comprising:

a toe wing extending back and away from said striking face toward the toe section of said head, wherein the wing extends laterally beyond the striking face toe lateral edge and is made from a first material;

a heel wing extending back and away from said striking face toward the heel section of said head, wherein the wing extends laterally beyond the striking face heel lateral edge and is made from a first material;

a shaft connection located between said wings; and wherein the remainder of the putter head is made from a second material lighter than said first material and weighting of the head is spread such that a greater portion of the total head weight extends beyond the lateral edges of the striking face.

14. A golf putter head according to claim 13, wherein the first material is tungsten.

15. A golf putter head according to claim 13, wherein the second lighter material is aluminum.

* * * * *