

COPY

**UNITED STATES DISTRICT COURT  
SOUTHERN DISTRICT OF NEW YORK**

LASERDYNAMICS USA, LLC,

Plaintiff,

-against-

TVA MEDIA GROUP, INC.,

Defendant.

Civil Action No.: \_\_\_\_\_

**COMPLAINT AND  
DEMAND FOR JURY TRIAL**

ECF Case

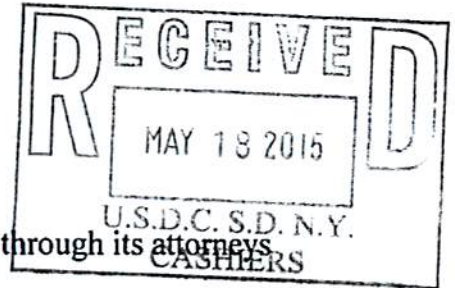

Plaintiff LaserDynamics USA, LLC ("LDUSA"), by and through its attorneys

Kheyfits & Maloney LLP, as and for its complaint against Defendant TVA Media Group, Inc.

("TVA"), hereby alleges as follows:

**NATURE OF THE ACTION**

1. This is an action under the patent laws of the United States, 35 U.S.C. §§ 1, *et seq.*, for infringement by Defendant TVA of one or more claims of U.S. Patent No's. 6,426,927 (the "'927 patent"), 6,529,469 (the "'469 patent") and 7,116,629 (the "'629 patent") (collectively, the '927, '469 and '629 patents are referred to herein as the "Patents-in-Suit").

**PARTIES**

2. Plaintiff LDUSA is a limited liability company organized and existing under the laws of the State of Delaware, having its principal place of business at 75 Montebello Road, Suffern, New York 10901.

3. On information and belief, Defendant TVA is a corporation organized and existing under the laws of the State of California, having its principal place of business at 3950 Vantage Avenue, Studio City, CA 91604.

## **JURISDICTION AND VENUE**

4. This Court has subject matter jurisdiction pursuant to 28 U.S.C. §§ 1331 and 1338(a).

5. This Court has personal jurisdiction over TVA pursuant to N.Y. C.P.L.R. §§ 301 and 302(a)(1)-(3). On information and belief, this Court has general jurisdiction over TVA based on its continuous and systematic conduct within New York, including, *inter alia*, TVA's continuous contacts with, and sales to, customers in New York, and importation of products into New York. On information and belief, TVA is also subject to specific jurisdiction of this Court because, *inter alia*, TVA has committed acts of patent infringement alleged in this Complaint within the state of New York and elsewhere, causing injury within the state.

6. Venue is proper in this district pursuant to 28 U.S.C. §§ 1391(b), 1391(c) and 1400(b) because, *inter alia*, Plaintiff LDUSA's principal place of business is located in this judicial district, the Patents-in-Suit are assigned to the Plaintiff, infringement of the Patents-in-Suit has occurred and is occurring in this judicial district, and Defendant TVA is a foreign entity.

## **BACKGROUND**

7. As referred to in this Complaint, and consistent with 35 U.S.C. § 100 (c), the "United States" means "the United States of America, its territories and possessions."

8. The '927 patent is entitled "Data Recording And Reproducing Method For Multi-Layered Optical Disk System."

9. The '469 patent is entitled "Data Recording And Reproducing Method For Multi-Layered Optical Disk System."

10. The '629 patent is entitled "Data Recording And Reproducing Method for Multi-Layered Optical Disk System."

11. The inventions of the Patents-in-Suit generally relate to optical disk recording and reproducing technologies.

12. Yasuo Kamatani invented the technology claimed in the Patents-in-Suit.

13. On information and belief, TVA manufactures, uses, sells, offers to sell and/or replicates dual-layer optical discs. On information and belief, at least the dual-layer optical discs currently replicated, manufactured, used, sold and/or offered for sale by TVA use the technology of the Patents-in-Suit.

14. By correspondence, including letters dated March 6, 2015 and May 4, 2015, non-party General Patent Corporation (“GPC”), in its role as the managing member of LDUSA, notified TVA of the existence of the Patents-in-Suit and TVA’s infringement thereof.

15. Accordingly, and on information and belief, Defendant TVA has received notice of the Patents-in-Suit, and of TVA’s infringement thereof.

**COUNT I: INFRINGEMENT OF THE PATENTS-IN-SUIT BY TVA**

16. Plaintiff incorporates the preceding paragraphs as if fully set forth herein.

17. On July 30, 2001, the United States Patent and Trademark Office duly and lawfully issued the ’927 patent, entitled “Data Recording And Reproducing Method For Multi-Layered Optical Disk System,” based upon an application filed by the inventor, Yasuo Kamatani. A true and correct copy of the ’927 patent is attached hereto as Exhibit A.

18. On March 4, 2003, the United States Patent and Trademark Office duly and lawfully issued the ’469 patent, entitled “Data Recording And Reproducing Method For Multi-Layered Optical Disk System,” based upon an application filed by the inventor, Yasuo Kamatani. A true and correct copy of the ’469 patent is attached hereto as Exhibit B.

19. On October 3, 2006, the United States Patent and Trademark Office duly and lawfully issued the '629 patent, entitled "Data Recording And Reproducing Method For Multi-Layered Optical Disk System," based upon an application filed by the inventor, Yasuo Kamatani. A true and correct copy of the '629 patent is attached hereto as Exhibit C.

20. LDUSA is the owner by assignment of the Patents-in-Suit, and has the right to sue and recover damages for infringement thereof.

21. TVA is not licensed under the Patents-in-Suit, yet TVA knowingly, actively, and lucratively practices the claimed inventions of the patents.

22. On information and belief, TVA has been and is now directly infringing one or more claims of the Patents-in-Suit by making, using, importing, providing, supplying, distributing, selling and/or offering to sell infringing products and is, therefore, liable to LDUSA pursuant to 35 U.S.C. § 271. TVA's infringing products include, but are not limited to, at least dual-layer optical discs.

23. TVA is therefore liable for direct infringement of the Patents-in-Suit pursuant to 35 U.S.C § 271(a).

24. On information and belief, TVA also indirectly infringes under 35 U.S.C. § 271(b) by way of inducing others, including its customers, to make, use, import, provide, supply, distribute, sell and offer to sell products that infringe one or more claims of the Patents-in-Suit in the United States generally, and in the Southern District of New York in particular. More specifically, on information and belief, TVA has knowledge of the Patents-in-Suit, intends to induce its customers to infringe the patents through its sales, offers for sale, and instructions and specifications provided to those customers, including but not limited to those relating to the replication of dual-layer optical discs, and understands that such actions amount to infringement.

Also, on information and belief, TVA, with knowledge of the Patents-in-Suit, offers additional services to induce prospective customers to retain TVA for the purpose of replicating infringing products and to practice the infringing methods. On information and belief, end users have used, and continue to use, the dual-layer optical discs in an infringing manner.

25. The acts of infringement by TVA have caused and will continue to cause damage to LDUSA. LDUSA is entitled to recover damages from TVA in an amount no less than a reasonable royalty pursuant to 35 U.S.C. § 284. The full measure of damages sustained as a result of TVA's wrongful acts will be proven at trial.

26. TVA has infringed and continues to infringe despite an objectively high likelihood that its actions constitute infringement of LDUSA's valid patent rights. On information and belief, TVA knew of or should have known of this objectively high risk at least as early as its receipt of this Complaint and/or when it became aware of the Patents-in-Suit or earlier. Thus, TVA's infringement of the Patents-in-Suit has been and continues to be willful.

27. LDUSA intends to seek discovery on the issue of willfulness and reserves the right to seek a willfulness finding and treble damages under 35 U.S.C. § 284 as well as its attorneys' fees and costs incurred in prosecuting this action under 35 U.S.C. § 285.

28. Upon information and belief, the acts of infringement by TVA will continue unless enjoined by this Court. LDUSA has been and will be irreparably harmed and damaged by the acts of infringement of the Patents-in-Suit by TVA and has no adequate remedy at law.

#### **PRAYER FOR RELIEF**

WHEREFORE, LDUSA prays for the judgment in its favor against TVA granting LDUSA the following relief:

- A. Entry of judgment in favor of LDUSA against TVA on all counts;
- B. Entry of judgment that TVA has infringed the Patents-in-Suit;
- C. Entry of judgment that TVA's infringement of the Patents-in-Suit has been willful;
- D. An order permanently enjoining TVA, together with their officers, directors, agents, servants, employees, and attorneys, and upon those persons in active concert or participation with them who receive actual notice of this order by personal service or otherwise, from infringing the Patents-in-Suit;
- E. Award of compensatory damages adequate to compensate LDUSA for TVA's infringement of the Patents-in-Suit, in no event less than a reasonable royalty trebled as provided by 35 U.S.C. § 284;
- F. LDUSA's costs;
- G. Pre-judgment and post-judgment interest on LDUSA's award; and
- H. All such other and further relief as the Court deems just or equitable.

**DEMAND FOR JURY TRIAL**

Pursuant to Rule 38 of the Fed. R. Civ. Proc., Plaintiff hereby demands trial by jury in this action of all claims so triable.

Dated: New York, New York  
May 18, 2015

**KHEYFITS & MALONEY LLP**

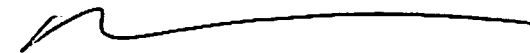
By:   
Michael James Maloney  
mmaloney@kheyfitsmaloney.com  
Dmitriy Kheyfits  
dkheyfits@kheyfitsmaloney.com  
1140 Avenue of the Americas  
9th Floor  
New York, New York 10036  
Tel. (212) 203-5399

**Fax. (212) 203-6445**

***Attorneys for Plaintiff LaserDynamics USA  
LLC***

# Exhibit A





US006426927B2

(12) **United States Patent**  
**Kamatani**

(10) **Patent No.:** US 6,426,927 B2  
(45) **Date of Patent:** Jul. 30, 2002

(54) **DATA RECORDING AND REPRODUCING METHOD FOR MULTI-LAYERED OPTICAL DISK SYSTEM**

5,579,294 A \* 11/1996 Ohta et al. .... 369/47.31  
6,134,200 A \* 10/2000 Timmermans ..... 369/47.28

(75) **Inventor:** Yasuo Kamatani, Sagamihara (JP)

\* cited by examiner

(73) **Assignee:** LaserDynamics, Inc. (JP)

*Primary Examiner*—Paul W. Huber

(\*) **Notice:** Subject to any disclaimer, the term of this patent is extended or adjusted under 35 U.S.C. 154(b) by 0 days.

(74) *Attorney, Agent, or Firm*—Trop, Pruner & Hu, P.C.

(57) **ABSTRACT**

(21) **Appl. No.:** 09/832,080

(22) **Filed:** Apr. 10, 2001

**Related U.S. Application Data**

(63) Continuation of application No. 09/370,308, filed on Aug. 9, 1999, now Pat. No. 6,215,743, which is a continuation of application No. 08/720,531, filed on Sep. 30, 1996, now Pat. No. 5,982,723.

A data recording and reproducing method for an optical disk data storage system to record data compressed at different data compression rate according to an operator's specification, and to reproduce the recorded data by decompressing. According to the operator's indication, the data is recorded at certain data compression rate in indicated area. The information of the data compression rate and the recorded area is stored as a table of contents (TOC) data. The TOC data is reproduced and stored in a memory after the optical disk is loaded. The recorded data is reproduced by selecting a decoding circuit to decompress the data. The decoding circuit is selected by referring the TOC data to identify data compression rate of the recorded data. Also the TOC data is referred to identify read-in and read-out region of the recorded data. The position of a pick-up when the data recording is started and ended, is recorded as the TOC data to provide random access capability for the data reproduction.

(51) **Int. Cl.**<sup>7</sup> ..... G11B 15/52

(52) **U.S. Cl.** ..... 369/47.19; 369/53.2; 369/275.3

(58) **Field of Search** ..... 369/32, 47.15, 369/47.22, 47.19, 47.35, 47.31, 47.32, 47.55, 53.2, 53.24, 53.31, 53.37, 53.41, 53.45, 53.44, 59.14, 59.25, 275.3

(56) **References Cited**

**U.S. PATENT DOCUMENTS**

5,553,044 A \* 9/1996 Tanaka ..... 369/47.52

14 Claims, 3 Drawing Sheets

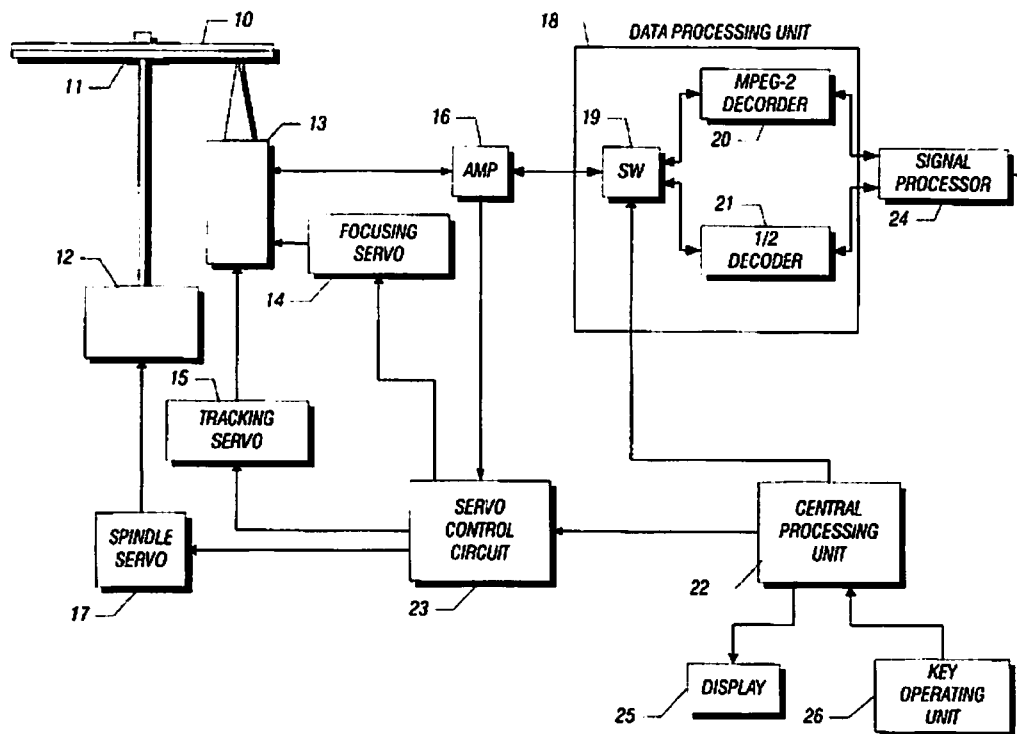

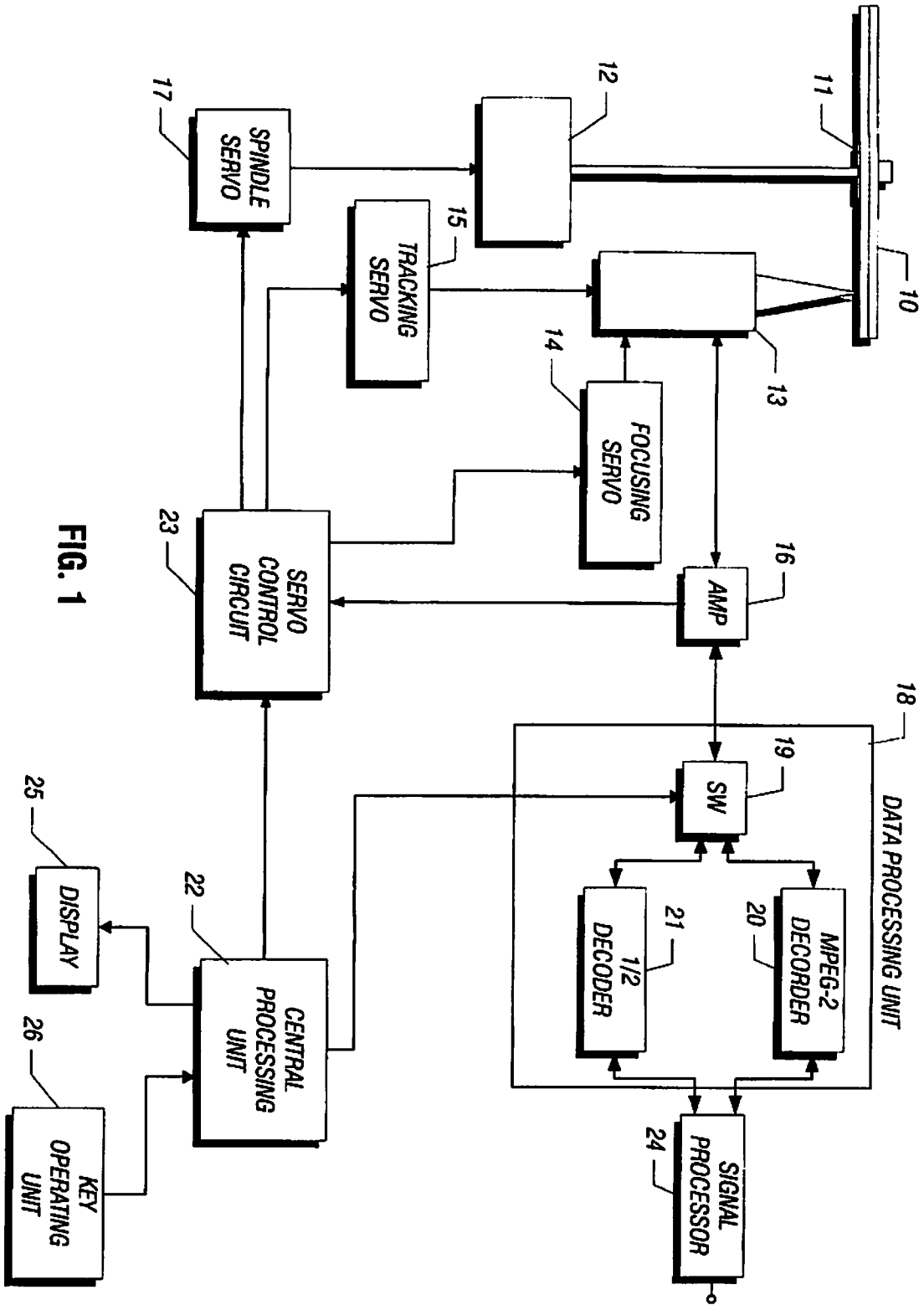

FIG. 1

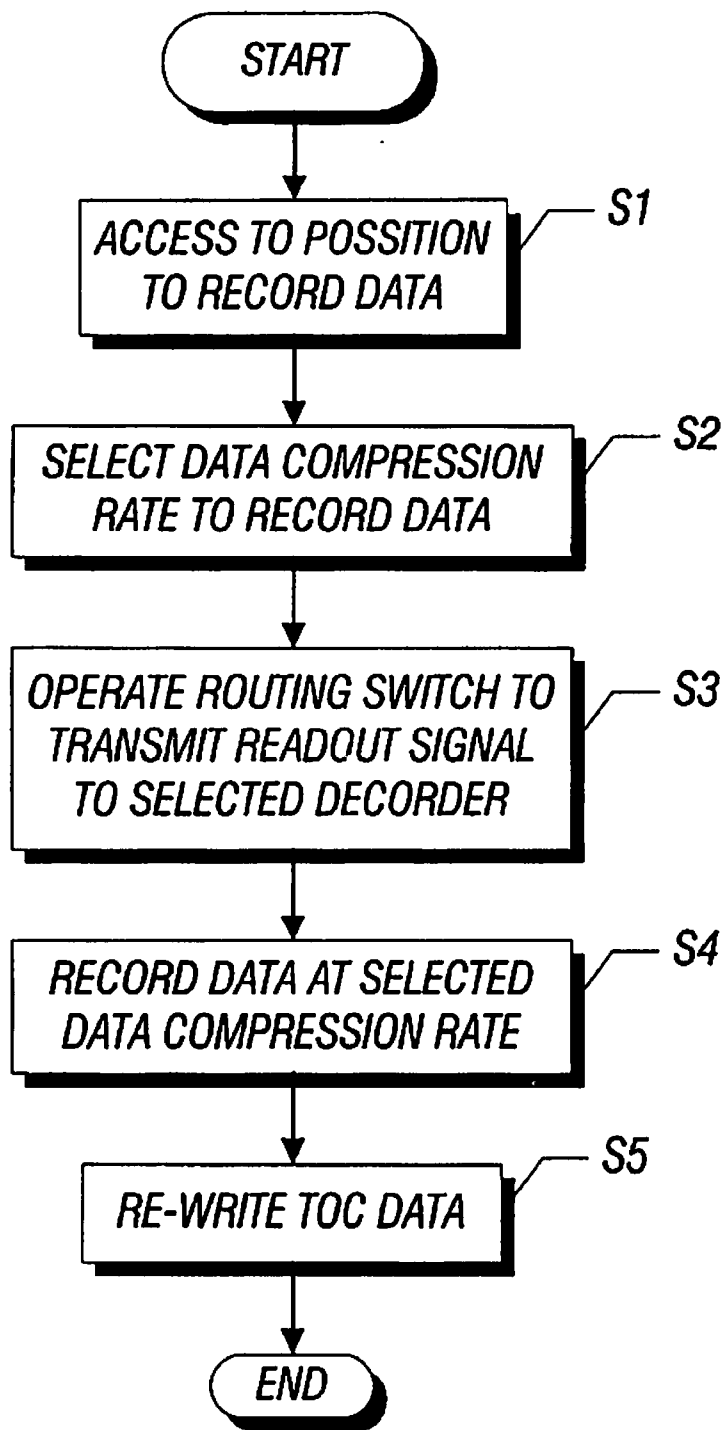

FIG. 2

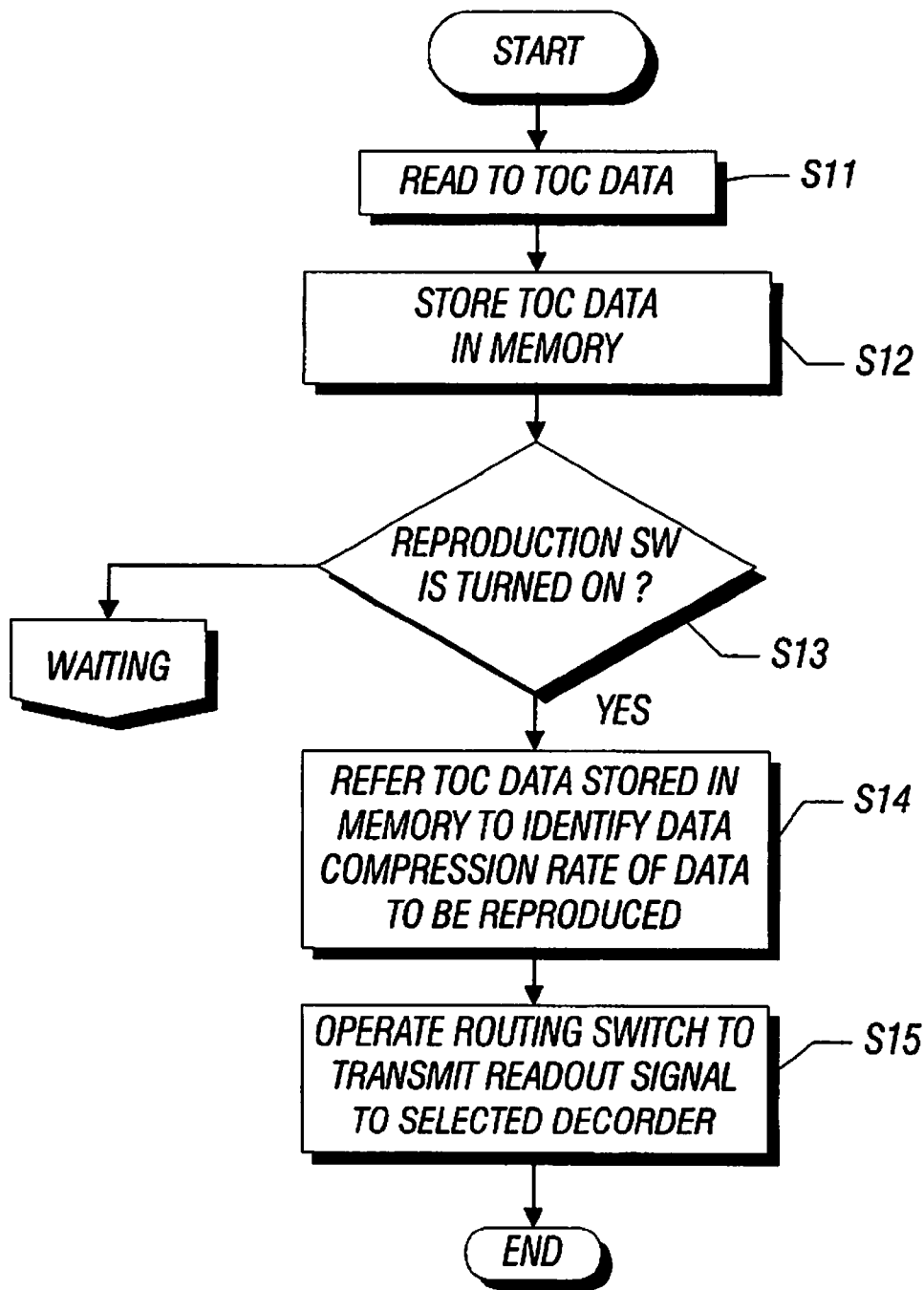

FIG. 3

US 6,426,927 B2

1

## DATA RECORDING AND REPRODUCING METHOD FOR MULTI-LAYERED OPTICAL DISK SYSTEM

This is a continuation of U.S. patent application Ser. No. 09/370,308, entitled, "DATA RECORDING AND REPRODUCING METHOD FOR MULTI-LAYERED OPTICAL DISK SYSTEM," filed on Aug. 9, 1999, now U.S. Pat. No. 6,215,743, which is a continuation of U.S. Ser. No. 08/720,531 filed on Sep. 30, 1996 entitled, "DATA RECORDING AND REPRODUCING METHOD FOR MULTI-LAYERED OPTICAL DISK SYSTEM," granted on Nov. 9, 1999, now U.S. Pat. No. 5,982,723.

### BACKGROUND OF THE INVENTION

#### 1. Field of the Invention

This invention relates to an optical data recording and reproducing method. More specifically, this invention relates to an optical disk recording and reproducing method which makes possible to record data encoded by different encoding circuit at different data compression rate and to reproduce the data.

#### 2. Description of the prior Art

Initialized by the vast increase in information that needs to be processed, optical data storage system having become very important system particularly because of their high storage density per area. Most of the recent optical information storage systems rotating single optical disk are used on which the information is digitally stored in concentric circular tracks in an ordered, predefined manner to allow chronological fast reading and fast random access to desired pits of data.

In order to accomplish even more storage capacity of optical disk systems for enormous information processing, such as video or picture communication like so called video-on-demand service, multiple disk systems have been proposed. An optical disk system equipped with two or more data layers may in theory be accessed as different disks by changing the focal point with moving lens. Example of this type of state-of-the-art include U.S. Pat. No. 5,202,875 issued Apr. 13, 1993 to Rosen et al.; Japanese Published Application, 63-276732 published Nov. 15, 1988 by Watanabe, et al.

Such a multiple disk recording and reading system is applied to varied optical disk information storage systems. For example, a digital video disk (DVD) system for home entertaining is one of the typical application. The mentioned advantage of vast storage capacity may contribute especially for video signal transmission. In order to record the video data efficiently onto the optical disk, a video data compression technique is one of the key technologies. A standardized video data compression rate has been proposed, which is called MPEG (Moving Picture Experts Group). However, for the home entertaining purposes, a more flexible function is required. The ability to record data at different data compression rates and to reproduce the recorded data, must be provided.

### SUMMARY OF THE INVENTION

The present invention has for its object to provide a multi-layered optical disk recording and reproducing system which is able to record data encoded by different encoding circuits at different data compression rates and to reproduce the data by a selected decoding circuit.

The object of the present invention can be achieved by an optical data recording and reproducing method, the record-

2

ing method comprising the steps of: loading a multi-layered optical disk which has M data layers (wherein M is an integer greater than 1), receiving an operator's signal to record data on an Nth data layer of the multi-layered optical disk at a certain data compression rate (wherein N is an integer greater than 1 and not greater than M), operating a routing circuit to transmit the data to a determined encoding circuit in order to compress the data at a predetermined data compression rate, recording the data on predetermined position at the predetermined data compression rate, and rewriting table of contents (TOC) data to record data about the data compression rate of the newly recorded data.

And the object of the present invention also can be achieved by an optical data recording and reproducing method, the reproducing method comprising the steps of: loading a multi-layered optical disk, which has M data layers (wherein M is an integer greater than 1), reproducing a table of contents (TOC) data recorded in the multi-layered optical disk, storing the reproduced TOC data in a memory, receiving an operator's signal to reproduce selected data stored in the multi-layered optical disk, referring to the TOC data stored in the memory to identify the data compression rate of the selected data, and operating a routing circuit to transmit a readout signal of the selected data to the determined encoding circuit in order to decompress the selected data.

For a fuller understanding of the nature and advantages of the present invention, reference should be made to the following detailed description taken in conjunction with the accompanying drawings.

### BRIEF DESCRIPTION OF THE DRAWINGS

FIG. 1 shows a block diagram of an example of an optical data recording and reproducing apparatus to which the present invention can be applied;

FIG. 2 shows a flowchart for a description of an optical disk recording method of the present invention; and

FIG. 3 shows a flowchart for a description of an optical disk reproducing method of the present invention.

### DETAILED DESCRIPTION OF THE PREFERRED EMBODIMENT

Embodiments of the present invention will be explained with reference to the drawings.

FIG. 1 shows a block diagram of a first example of an optical data recording and reproducing apparatus to which the present invention can be applied. A digital video disk (DVD) 10 which has more than two data layers is mounted on and secured by a turntable 11 to be rotated by a spindle motor 12. Encoded pits on the DVD 10 are read by a pickup 13 which includes a laser diode, a focusing lens, a focusing lens actuator, a tracking actuator and a photo-detector. The movement of the pick-up 13 is controlled by a focusing servo circuit 14 and a tracking servo circuit 15.

To reproduce data encoded on the DVD 10, the output signal from the pickup 13 is transmitted to an amplifier 16. According to a focusing error signal, the focusing servo circuit 14 modulates the focusing lens actuator to move the focal point of the laser beam emitted from the laser diode by moving the focusing lens, to access one of the data layer of the DVD 10. And according to a tracking error signal, the tracking servo circuit 15 modulates the tracking actuator to control position of the pickup 13. The spindle servo circuit 17 modulates the spindle motor 12 in order to track linear velocity of the DVD 10.

US 6,426,927 B2

3

The detected signal by the pick-up 13 is amplified by the amplifier 16. And the amplified signal is transmitted to a data processing unit 18 which is composed of a routing switch 19, an MPEG-2 decoder 20 and a ½ decoder 21. The MPEG-2 decoder 20 is a standardized data encoding or decoding circuit for a Digital Video Disk (DVD), provided in order to encode a data signal for recording on the disk and to decode the read out signal for signal processing. The ½ decoder 21 is a data encoding or decoding circuit provided to encode and compress the applied data signal to half data rate of the standardized DVD format. Due to the data compression by the ½ decoder 21, the quality of the data must be sacrificed in order to record longer data per recording area. However, it makes it possible to provide additional functionality and flexibility for the user. A set of TOC data encoded at a read-in region of the DVD 10, must include the data indicative of the starting and ending position of each data portion, and the data compression rate of each data. The TOC data is reproduced right after the DVD is loaded, and then the each data reproduction is preceded by referring the TOC data. And the TOC data must be rewritten after new data is recorded.

The routing switch 19 is operated by a central processing unit (CPU) 22 according to the detected TOC data, which includes the data indicating the compression rate of each data to determine the appropriate decoding circuit. The TOC data is also transmitted to a servo control circuit 23 which modulates the focusing servo circuit 14, the tracking servo circuit 15 and the spindle servo circuit 17. The servo control circuit 23 modulates each servo circuit to access selected data according to the TOC data which indicates the data indicating the starting and ending positions of each encoded data portion. Then the decoded signal is transmitted to a signal processor 24 to transmit the reproduced data signal to any connected unit, such as a display system or sound system. The CPU 22 is operated by an operation signal from a key operating unit 26 which transmits all operating signals input by an operator. The CPU 22 also controls a display unit 25 to show the operating status of the operator.

To record data onto the DVD 10, a portion of an input data is transmitted from the signal processor 24 to the chosen decoder in the data processing unit according to the operator's command. The input data signal is encoded by the selected decoder, then recorded by the pick-up 13 which is driven by the each servo circuit and the servo control circuit 23. After the new data is recorded on the DVD 10, the TOC data is rewritten to store the data indicating the position and data compression rate of the newly recorded data.

In addition, by storing the data of read-in and readout position of the all recorded data as TOC data, a capability of quick random access to any data portion is provided for the data reproduction process. For example, in order to reproduce one data and another data continuously, the pick-up head can rapidly switch access from readout region of the first data to the read-in region of the second data, if data as to all of the read-in region's position is stored and recorded in the TOC data. In the prior art system, all of the read-in region of the data between the first and second data must be counted by detecting the readout signal. For example, in order to reproduce both a 4<sup>th</sup> data element and a 14<sup>th</sup> data element recorded on the disk, the pick-up must detect and count ten read-in regions of the data between 4<sup>th</sup> and 14<sup>th</sup> data regions by moving the pick-up all over the disk. The present invention can provide the advantage of reproducing the data continuously without timelag. The advantage may contribute remarkably to the multi-layered optical disk reading systems which is equipped with more than two data layers.

4

FIG. 2 shows a flowchart of operation processing in a central processing unit (CPU), while recording data onto one data layer of a multi-layered optical disk. After a multi-layered optical disk which has M data layers (wherein M is an integer greater than 1) is loaded, the CPU receives an operator's signal to record data on the N<sup>th</sup> data layer of multi-layered optical disk (wherein N is an integer greater than 1 and not greater than M). The CPU operates a servo control circuit to dispose a pick-up in order to access read-in region of the data to be recorded (Step 1:S1). According to the operator's selection of a data compression rate (S2), the CPU operates a routing circuit to transmit the data the determined encoding circuit in order to compress the data at the selected data compression rate (S3). The CPU operates a servo control circuit to record the data on a predetermined position at the predetermined data compression rate (S4). After the data recording is completed, the CPU operates a servo control circuit to rewrite a table of contents (TOC) data to record data indicating the data compression rate of the newly recorded data (S5).

FIG. 3 shows a flowchart of an operation processing with reference to the CPU, while reproducing data which is recorded by the procedure described in FIG. 2. After a multi-layered optical disk which has M data layers, wherein M is an integer greater than 1, is loaded, the CPU operates the servo control circuit to reproduce table of contents (TOC) data recorded in the multilayered optical disk (S11). Then the CPU stores the reproduced TOC data in a memory (S12). When the CPU receives an operator's signal to reproduce certain data from the optical disk (S13), the CPU refers to the TOC data stored in the memory to identify the data compression rate of the selected data (S14). Then the CPU operates the routing switch to transmit a readout signal of the selected data to a determined encoding circuit in order to decompress the selected data (S15). After all of these procedures are completed, the data reproduction is started.

Although the invention has been particularly shown and described, it is contemplated that various changes and modification may be made without departing from the scope of the invention as set forth in the following claims.

What is claimed is:

1. An article comprising an optical disk comprising:
  - a contents data region indicating a layer, a location and a data encoding technique of recorded data in the optical disk; and
  - a control data region to read out the recorded data in reference to the layer, the location and the data encoding technique.
2. The article of claim 1, wherein the optical disk comprises a DVD disk.
3. An article comprising an optical disk comprising:
  - a first region referenced by a layer and a location, the first region indicating input data stored on the disk and the input data being encoded in accordance with a data encoding technique; and
  - a physical format information region indicating the data encoding technique, the layer and the location.
4. The article of claim 3, wherein the physical format information region comprises a table of contents.
5. The article of claim 3, wherein the physical format information region is separate from the first region.
6. The article of claim 3, wherein the optical disk comprises a DVD disk.
7. An optical disk adapted to be coupled to an optical disk drive and usable in association with a processor coupled to the optical disk drive, said optical disk causing the processor to:

US 6,426,927 B2

5

- i) retrieve a table of contents data written on said optical disk;
  - ii) store the retrieved table of contents data into a memory;
  - iii) from the table of contents data stored in the memory, identify a data encoding technique and a layer and a location in which recorded data is stored;
  - iv) read out and route the recorded data at the identified layer and the identified location to a data decoder; and
  - v) decode the read out recorded data in reference to the identified data encoding technique.
8. The optical disk of claim 7, wherein the optical disk comprises a DVD disk.
9. A computer system comprising:
- an optical disk drive adapted to receive an optical disk; and
  - a processor coupled to the optical disk drive and adapted to:
    - i) retrieve a table of contents data written on an optical disk;
    - ii) store the retrieved table of contents data into a memory;
    - iii) from the table of contents data stored in the memory, identify a data encoding technique and a layer and location in which recorded data is stored;

6

- iv) read out and route the recorded data at the identified layer and the identified location to a data decoder; and
  - v) decode the read out recorded data in reference to the identified data encoding technique.
10. The computer system of claim 9, wherein the optical disk comprises a DVD disk.
11. A method usable with an optical disk, comprising: recording input data on the optical disk, the input data being encoded with a data encoding technique and being referenced by a layer and location; and recording an indication of the layer, the location and the data encoding technique in a physical format information region of the disk.
12. The method of claim 11, wherein the physical format information region comprises a table of contents.
13. The method of claim 11, wherein the physical format information region is separate from a region where the input data is recorded.
14. The method of claim 11, wherein the optical disk comprises a DVD disk.

\* \* \* \* \*

# Exhibit B





US006529469B2

(12) **United States Patent**  
**Kamatani**

(10) **Patent No.:** **US 6,529,469 B2**  
(45) **Date of Patent:** **Mar. 4, 2003**

(54) **DATA RECORDING AND REPRODUCING METHOD FOR MULTI-LAYERED OPTICAL DISK SYSTEM**

(75) **Inventor:** Yasuo Kamatani, Sagamihara (JP)

(73) **Assignee:** LaserDynamics, Inc. (JP)

(\*) **Notice:** Subject to any disclaimer, the term of this patent is extended or adjusted under 35 U.S.C. 154(b) by 0 days.

- 5,010,539 A \* 4/1991 Terashima et al. .... 369/47.41
- 5,177,728 A \* 1/1993 Otsubo et al. .... 369/47.24
- 5,249,170 A \* 9/1993 Yoshimaru et al. .... 369/47.54
- 5,289,451 A \* 2/1994 Ashinuma et al. .... 369/53.22
- 5,315,570 A \* 5/1994 Miura et al. .... 369/47.24
- 5,436,878 A \* 7/1995 Yamaguchi et al. .... 369/53.2
- 5,715,355 A \* 2/1998 Yonemitsu et al. .... 369/275.3

\* cited by examiner

(21) **Appl. No.:** 09/949,689

(22) **Filed:** Sep. 10, 2001

(65) **Prior Publication Data**

US 2002/0006085 A1 Jan. 17, 2002

**Related U.S. Application Data**

(63) Continuation of application No. 09/670,890, filed on Sep. 28, 2000, now Pat. No. 6,339,568, which is a division of application No. 09/370,308, filed on Aug. 9, 1999, now Pat. No. 6,215,743, which is a continuation of application No. 08/720,531, filed on Sep. 30, 1996, now Pat. No. 5,982,723.

(51) **Int. Cl.<sup>7</sup>** ..... G11B 7/24

(52) **U.S. Cl.** ..... 369/275.3; 369/30.04; 369/53.2

(58) **Field of Search** ..... 369/30.04, 30.03, 369/30.07, 30.3, 32.01, 47.28, 47.29, 47.3, 47.31, 47.55, 53.2, 53.24, 53.34, 53.37, 53.41, 53.45, 124.06, 275.3

(56) **References Cited**

**U.S. PATENT DOCUMENTS**

4,853,915 A \* 8/1989 Takasago et al. .... 369/53.31

*Primary Examiner*—Paul W. Huber

(74) *Attorney, Agent, or Firm*—Trop, Pruner & Hu, P.C.

(57) **ABSTRACT**

A data recording and reproducing method for an optical disk data storage system to record data compressed at different data compression rate according to an operator's specification, and to reproduce the recorded data by decompressing. According to the operator's indication, the data is recorded at certain data compression rate in indicated area. The information of the data compression rate and the recorded area is stored as a table of contents (TOC) data. The TOC data is reproduced and stored in a memory after the optical disk is loaded. The recorded data is reproduced by selecting a decoding circuit to decompress the data. The decoding circuit is selected by referring the TOC data to identify data compression rate of the recorded data. Also the TOC data is referred to identify read-in and read-out region of the recorded data. The position of a pick-up when the data recording is started and ended, is recorded as the TOC data to provide random access capability for the data reproduction.

**18 Claims, 3 Drawing Sheets**

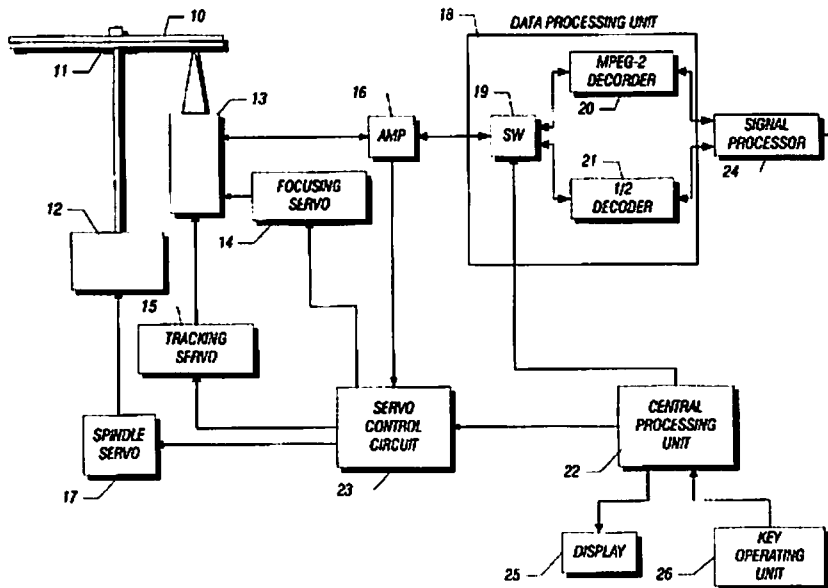

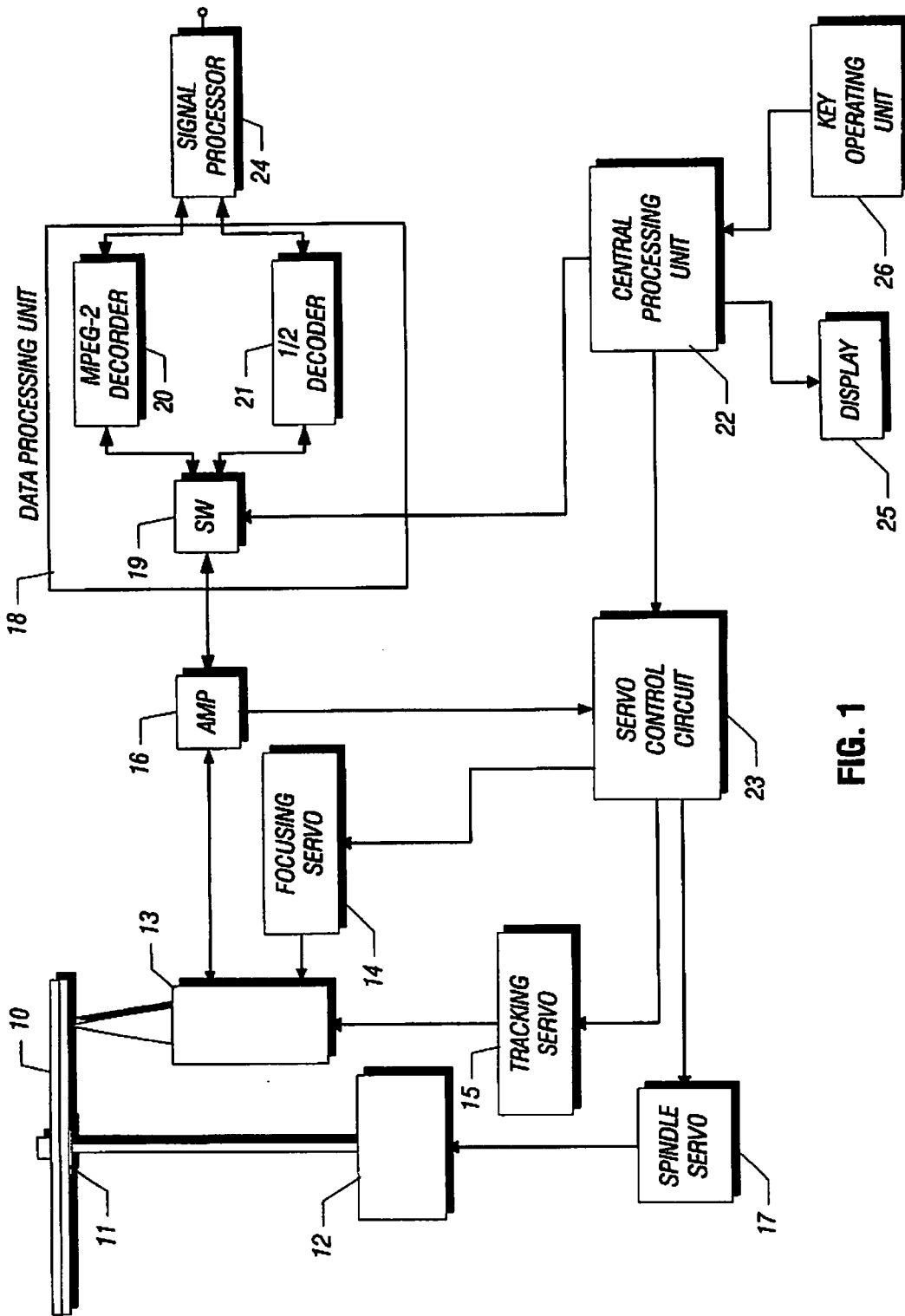

FIG. 1

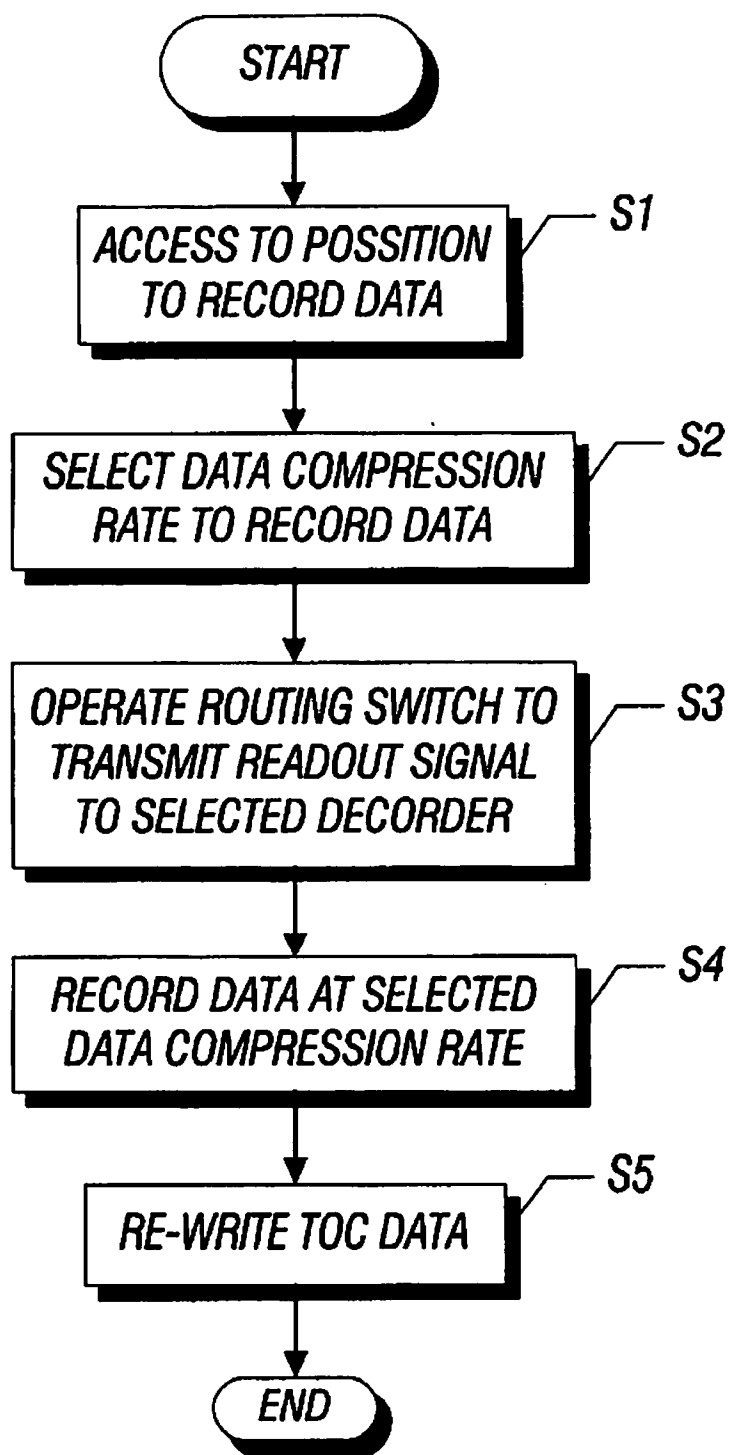

FIG. 2

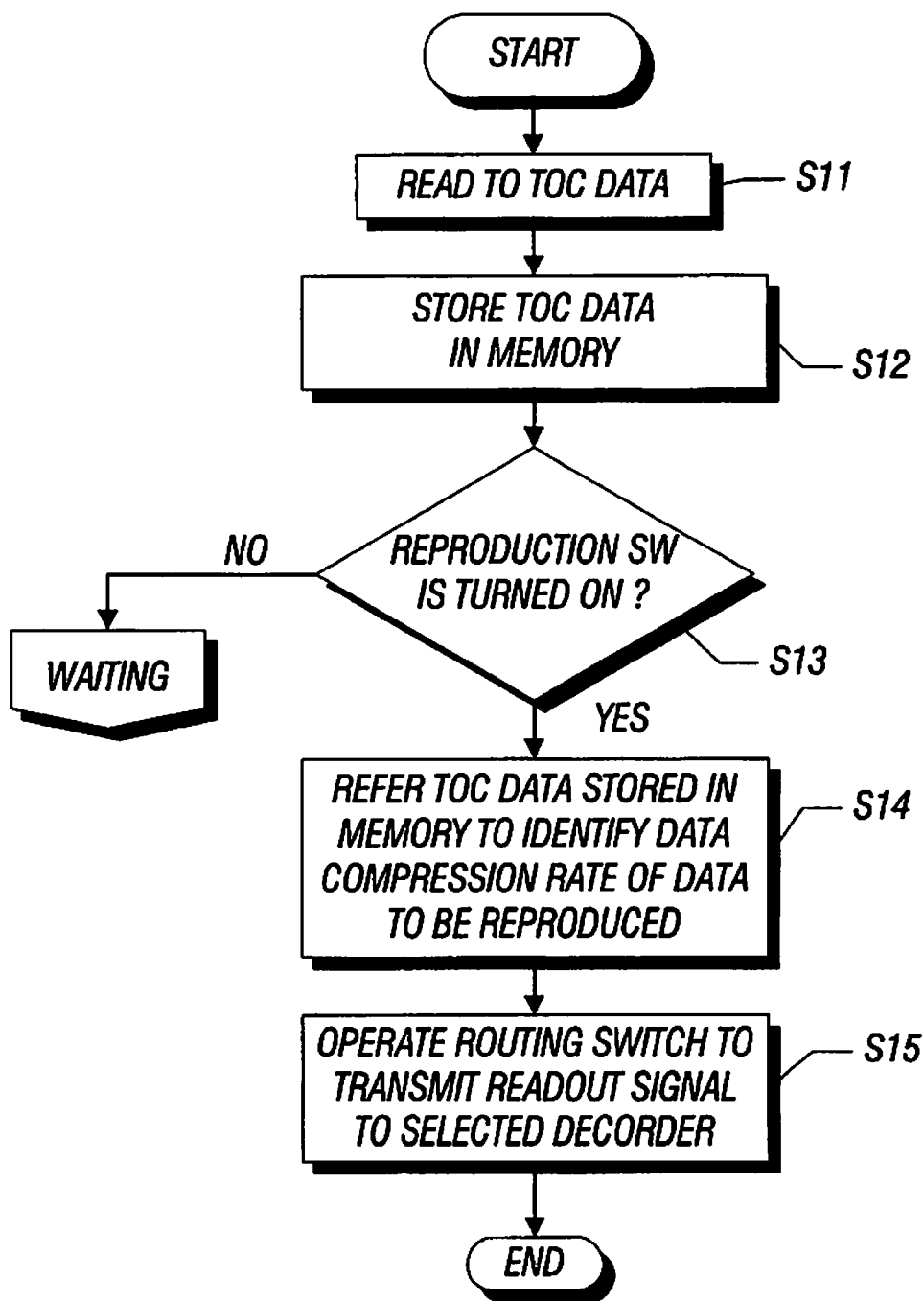

FIG. 3

US 6,529,469 B2

1

## DATA RECORDING AND REPRODUCING METHOD FOR MULTI-LAYERED OPTICAL DISK SYSTEM

This is a continuation of U.S. patent application Ser. No. 09/670,890, now U.S. Pat. No. 6,339,568 entitled, "DATA RECORDING AND REPRODUCING METHOD FOR MULTI-LAYERED OPTICAL DISK SYSTEM," filed Sep. 28, 2000, granted on Jan. 15, 2002, which is a divisional of application Ser. No. 09/370,308, filed Aug. 9, 1999, now U.S. Pat. No. 6,215,743 entitled, "DATA RECORDING AND REPRODUCING METHOD FOR MULTI-LAYERED OPTICAL DISK SYSTEM," granted on Apr. 10, 2001, which is a continuation of application Ser. No. 08/720,531, filed Sep. 30, 1996, now U.S. Pat. No. 5,982,723 entitled, "DATA RECORDING AND REPRODUCING METHOD FOR MULTI-LAYERED OPTICAL DISK SYSTEM," granted on Nov. 9, 1999.

### BACKGROUND OF THE INVENTION

#### 1. Field of the Invention

This invention relates to an optical data recording and reproducing method. More specifically, this invention relates to an optical disk recording and reproducing method which makes possible to record data encoded by different encoding circuit at different data compression rate and to reproduce the data.

#### 2. Description of the Prior Art

Initialized by the vast increase in information that needs to be processed, optical data storage system having become very important system particularly because of their high storage density per area. Most of the recent optical information storage systems rotating single optical disk are used on which the information is digitally stored in concentric circular tracks in an ordered, predefined manner to allow chronological fast reading and fast random access to desired pits of data.

In order to accomplish even more storage capacity of optical disk systems for enormous information processing, such as video or picture communication like so called video-on-demand service, multiple disk systems have been proposed. An optical disk system equipped with two or more data layers may in theory be accessed as different disks by changing the focal point with moving lens. Example of this type of state-of-the-art include U.S. Pat. No. 5,202,875 issued Apr. 13, 1993 to Rosen et al.; Japanese Published Application, 63-276732 published Nov. 15, 1988 by Watanabe, et al.

Such a multiple disk recording and reading system is applied to varied optical disk information storage systems. For example, a digital video disk (DVD) system for home entertaining is one of the typical application. The mentioned advantage of vast storage capacity may contribute especially for video signal transmission. In order to record the video data efficiently onto the optical disk, a video data compression technique is one of the key technologies. A standardized video data compression rate has been proposed, which is called MPEG (Moving Picture Experts Group). However, for the home entertaining purposes, a more flexible function is required. The ability to record data at different data compression rates and to reproduce the recorded data, must be provided.

#### 3. SUMMARY OF THE INVENTION

The present invention has for its object to provide a multi-layered optical disk recording and reproducing system

2

which is able to record data encoded by different encoding circuits at different data compression rates and to reproduce the data by a selected decoding circuit.

The object of the present invention can be achieved by an optical data recording and reproducing method, the recording method comprising the steps of: loading a multi-layered optical disk which has M data layers (wherein M is an integer greater than 1), receiving an operator's signal to record data on an Nth data layer of the multi-layered optical disk at a certain data compression rate (wherein N is an integer greater than 1 and not greater than M), operating a routing circuit to transmit the data to a determined encoding circuit in order to compress the data at a predetermined data compression rate, recording the data on predetermined position at the predetermined data compression rate, and rewriting table of contents (TOC) data to record data about the data compression rate of the newly recorded data.

And the object of the present invention also can be achieved by an optical data recording and reproducing method, the reproducing method comprising the steps of: loading a multi-layered optical disk, which has M data layers (wherein M is an integer greater than 1), reproducing a table of contents (TOC) data recorded in the multi-layered optical disk, storing the reproduced TOC data in a memory, receiving an operator's signal to reproduce selected data stored in the multi-layered optical disk, referring to the TOC data stored in the memory to identify the data compression rate of the selected data, and operating a routing circuit to transmit a readout signal of the selected data to the determined encoding circuit in order to decompress the selected data.

For a fuller understanding of the nature and advantages of the present invention, reference should be made to the following detailed description taken in conjunction with the accompanying drawings.

#### 4. BRIEF DESCRIPTION OF THE DRAWINGS

FIG. 1 shows a block diagram of an example of an optical data recording and reproducing apparatus to which the present invention can be applied;

FIG. 2 shows a flowchart for a description of an optical disk recording method of the present invention; and

FIG. 3 shows a flowchart for a description of an optical disk reproducing method of the present invention.

#### 5. DETAILED DESCRIPTION OF THE PREFERRED EMBODIMENT

Embodiments of the present invention will be explained with reference to the drawings.

FIG. 1 shows a block diagram of a first example of an optical data recording and reproducing apparatus to which the present invention can be applied. A digital video disk (DVD) 10 which has more than two data layers is mounted on and secured by a turntable 11 to be rotated by a spindle motor 12. Encoded pits on the DVD 10 are read by a pickup 13 which includes a laser diode, a focusing lens, a focusing lens actuator, a tracking actuator and a photo-detector. The movement of the pick-up 13 is controlled by a focusing servo circuit 14 and a tracking servo circuit 15.

To reproduce data encoded on the DVD 10, the output signal from the pickup 13 is transmitted to an amplifier 16. According to a focusing error signal, the focusing servo circuit 14 modulates the focusing lens actuator to move the focal point of the laser beam emitted from the laser diode by moving the focusing lens, to access one of the data layer of

US 6,529,469 B2

3

the DVD 10. And according to a tracking error signal, the tracking servo circuit 15 modulates the tracking actuator to control position of the pickup 13. The spindle servo circuit 17 modulates the spindle motor 12 in order to track linear velocity of the DVD 10.

The detected signal by the pick-up 13 is amplified by the amplifier 16. And the amplified signal is transmitted to a data processing unit 18 which is composed of a routing switch 19, an MPEG-2 decoder 20 and a  $\frac{1}{2}$  decoder 21. The MPEG-2 decoder 20 is a standardized data encoding or decoding circuit for a Digital Video Disk (DVD), provided in order to encode a data signal for recording on the disk and to decode the read out signal for signal processing. The  $\frac{1}{2}$  decoder 21 is a data encoding or decoding circuit provided to encode and compress the applied data signal to half data rate of the standardized DVD format. Due to the data compression by the  $\frac{1}{2}$  decoder 21, the quality of the data must be sacrificed in order to record longer data per recording area. However, it makes it possible to provide additional functionality and flexibility for the user. A set of TOC data encoded at a read-in region of the DVD 10, must include the data indicative of the starting and ending position of each data portion, and the data compression rate of each data. The TOC data is reproduced right after the DVD is loaded, and then the each data reproduction is preceded by referring the TOC data. And the TOC data must be rewritten after new data is recorded.

The routing switch 19 is operated by a central processing unit (CPU) 22 according to the detected TOC data, which includes the data indicating the compression rate of each data to determine the appropriate decoding circuit. The TOC data is also transmitted to a servo control circuit 23 which modulates the focusing servo circuit 14, the tracking servo circuit 15 and the spindle servo circuit 17. The servo control circuit 23 modulates each servo circuit to access selected data according to the TOC data which indicates the data indicating the starting and ending positions of each encoded data portion. Then the decoded signal is transmitted to a signal processor 24 to transmit the reproduced data signal to any connected unit, such as a display system or sound system. The CPU 22 is operated by an operation signal from a key operating unit 26 which transmits all operating signals input by an operator. The CPU 22 also controls a display unit 25 to show the operating status of the operator.

To record data onto the DVD 10, a portion of an input data signal is transmitted from the signal processor 24 to the chosen decoder in the data processing unit according to the operator's command. The input data signal is encoded by the selected decoder, then recorded by the pick-up 13 which is driven by the each servo circuit and the servo control circuit 23. After the new data is recorded on the DVD 10, the TOC data is rewritten to store the data indicating the position and data compression rate of the newly recorded data.

In addition, by storing the data of read-in and readout position of the all recorded data as TOC data, a capability of quick random access to any data portion is provided for the data reproduction process. For example, in order to reproduce one data and another data continuously, the pick-up head can rapidly switch access from readout region of the first data to the read-in region of the second data, if data as to all of the read-in region's position is stored and recorded in the TOC data. In the prior art system, all of the read-in region of the data between the first and second data must be counted by detecting the readout signal. For example, in order to reproduce both a  $4_{\mu}$  data element and a  $14_{\mu}$  data element recorded on the disk, the pick-up must detect and count ten read-in regions of the data between  $4_{\mu}$  and  $14_{\mu}$

4

data regions by moving the pick-up all over the disk. The present invention can provide the advantage of reproducing the data continuously without timelag. The advantage may contribute remarkably to the multi-layered optical disk reading systems which is equipped with more than two data layers.

FIG. 2 shows a flowchart of operation processing in a central processing unit (CPU), while recording data onto one data layer of a multi-layered optical disk. After a multi-layered optical disk which has M data layers (wherein M is an integer greater than 1) is loaded, the CPU receives an operator's signal to record data on the Nth data layer of multi-layered optical disk (wherein N is an integer greater than 1 and not greater than M). The CPU operates a servo control circuit to dispose a pick-up in order to access read-in region of the data to be recorded (Step 1:S1). According to the operator's selection of a data compression rate (S2), the CPU operates a routing circuit to transmit the data the determined encoding circuit in order to compress the data at the selected data compression rate (S3). The CPU operates a servo control circuit to record the data on a predetermined position at the predetermined data compression rate (S4). After the data recording is completed, the CPU operates a servo control circuit to rewrite a table of contents (TOC) data to record data indicating the data compression rate of the newly recorded data (S5).

FIG. 3 shows a flowchart of an operation processing with reference to the CPU, while reproducing data which is recorded by the procedure described in FIG. 2. After a multi-layered optical disk which has M data layers, wherein M is an integer greater than 1, is loaded, the CPU operates the servo control circuit to reproduce table of contents (TOC) data recorded in the multi-layered optical disk (S11). Then the CPU stores the reproduced TOC data in a memory (S12). When the CPU receives an operator's signal to reproduce certain data from the optical disk (S13), the CPU refers to the TOC data stored in the memory to identify the data compression rate of the selected data (S14). Then the CPU operates the routing switch to transmit a readout signal of the selected data to a determined encoding circuit in order to decompress the selected data (S15). After all of these procedures are completed, the data reproduction is started.

Although the invention has been particularly shown and described, it is contemplated that various changes and modification may be made without departing from the scope of the invention as set forth in the following claims.

What is claimed is:

1. An optical disk defining a recording region therein, the optical disk storing:
  - first control data indicative of a data transfer rate associated with the recording region;
  - second control data indicative of a recording density associated with the recording region; and
  - third control data indicative of a location of the recording region.
2. The optical disk of claim 1, wherein the third control data indicates a starting position and an ending position of the recording region.
3. The optical disk of claim 1, wherein the optical disk further stores fourth control data, the fourth control data being indicative of layer information.
4. The optical disk of claim 1, wherein the data transfer rate and the recording density are associated with a data compression technique.
5. The optical disk of claim 1, wherein the optical disk comprises a read only optical disk.

US 6,529,469 B2

5

6. The optical disk of claim 1, wherein the optical disk stores a set of encoded data in the recording region.

7. The optical disk of claim 6, wherein the set of encoded data includes moving picture data.

8. The optical disk of claim 6, wherein the set of encoded data includes sound data.

9. The optical disk of claim 1, wherein the optical disk comprises a recordable disk.

10. An optical disk defining a table of contents data region and a recording region therein, the optical disk storing:

first control data stored in the table of contents data region, the first control data being indicative of a data transfer rate associated with the recording region;

second control data stored in the table of contents data region, the second control data being indicative of a recording density associated with the recording region; and

third control data indicative of a location of the recording region.

6

11. The optical disk of claim 10, wherein the third control data indicates a starting position and an ending position of the recording region.

12. The optical disk of claim 10, wherein the optical disk further stores fourth control data, the fourth control data being indicative of layer information.

13. The optical disk of claim 10, wherein the data transfer rate and the recording density are associated with a data compression technique.

14. The optical disk of claim 10, wherein the optical disk comprises a read only optical disk.

15. The optical disk of claim 10, wherein the optical disk stores a set of encoded data in the recording region.

16. The optical disk of claim 15, wherein the set of encoded data includes moving picture data.

17. The optical disk of claim 15, wherein the set of encoded data includes sound data.

18. The optical disk of claim 10, wherein the optical disk comprises a recordable disk.

\* \* \* \* \*

# Exhibit C





US007116629B2

(12) **United States Patent**  
**Kamatani**

(10) **Patent No.:** **US 7,116,629 B2**  
(45) **Date of Patent:** **Oct. 3, 2006**

(54) **DATA RECORDING AND REPRODUCING METHOD FOR MULTI-LAYERED OPTICAL DISK SYSTEM**

(75) Inventor: **Yasuo Kamatani**, Sagamihara (JP)  
(73) Assignee: **LaserDynamics, Inc.**, (JP)  
(\* ) Notice: Subject to any disclaimer, the term of this patent is extended or adjusted under 35 U.S.C. 154(b) by 0 days.  
(21) Appl. No.: **10/328,100**  
(22) Filed: **Dec. 23, 2002**

(65) **Prior Publication Data**  
US 2003/0142600 A1 Jul. 31, 2003

**Related U.S. Application Data**  
(60) Continuation of application No. 09/949,689, filed on Sep. 10, 2001, now Pat. No. 6,529,469, which is a continuation of application No. 09/670,890, filed on Sep. 28, 2000, now Pat. No. 6,339,568, which is a division of application No. 09/370,308, filed on Aug. 9, 1999, now Pat. No. 6,215,743, which is a continuation of application No. 08/720,531, filed on Sep. 30, 1996, now Pat. No. 5,982,723.

(51) **Int. Cl.**  
**G11B 3/74** (2006.01)  
(52) **U.S. Cl.** ..... **369/275.3; 369/275.3**  
(58) **Field of Classification Search** ..... 369/30.03, 369/30.04, 53.2, 53.41, 94, 275.3, 124.06, 369/124.07  
See application file for complete search history.

(56) **References Cited**  
U.S. PATENT DOCUMENTS  
4,853,915 A 8/1989 Takasago et al. .... 369/32

(Continued)

OTHER PUBLICATIONS

DVD Forum, DVD Book Construction ([www.dvdfllc.co.jp/bookcon.pdf](http://www.dvdfllc.co.jp/bookcon.pdf) —printed Sep. 2005). This listing of “DVD Specifications” refers to the “DVD Specification for Read-Only Disc” which may be dated as early as Aug. or Sep. 1996, through this information should not be construed as an admission that the “DVD Specification for Read-Only Disc” was “published” as of this date. Because the official DVD Specification books are available only after signing a nondisclosure agreement and paying a \$5,000 fee ([www.dvdfllc.co.jp/howto.htm](http://www.dvdfllc.co.jp/howto.htm)), it is Applicant’s understanding that the nondisclosure agreement provisions prohibit Applicant from submitting a copy of the DVD Specification documents. In any event, Applicant does not have a copy of the referenced DVD Specification documents. Contact DVD Format/Logo Licensing Corporation (DVD FLLC) at [www.dvdfllc.co.jp](http://www.dvdfllc.co.jp) for additional information.

*Primary Examiner*—Paul W. Huber  
(74) *Attorney, Agent, or Firm*—Hamilton & Terrile, LLP; Michael Rocco Cannatti

(57) **ABSTRACT**

A data recording and reproducing method for an optical disk data storage system to record data compressed at different data compression rate according to an operator’s specification, and to reproduce the recorded data by decompressing. According to the operator’s indication, the data is recorded at certain data compression rate in indicated area. The information of the data compression rate and the recorded area is stored as a table of contents (TOC) data. The TOC data is reproduced and stored in a memory after the optical disk is loaded. The recorded data is reproduced by selecting a decoding circuit to decompress the data. The decoding circuit is selected by referring the TOC data to identify data compression rate of the recorded data. Also the TOC data is referred to identify read-in and read-out region of the recorded data. The position of a pick-up when the data recording is started and ended, is recorded as the TOC data to provide random access capability for the data reproduction.

**32 Claims, 3 Drawing Sheets**

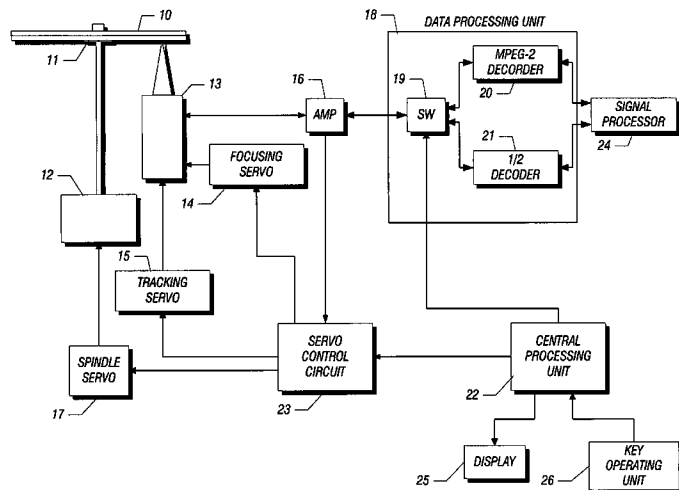

**US 7,116,629 B2**

Page 2

---

U.S. PATENT DOCUMENTS								
5,010,539	A	4/1991	Terashima et al. ....	369/50	5,715,355 A	2/1998	Yonemitsu et al. ....	386/95
5,177,728	A	1/1993	Otsubo et al. ....	369/48	5,734,787 A *	3/1998	Yonemitsu et al. ....	386/111
5,249,170	A	9/1993	Yoshimaru et al. ....	369/48	5,745,643 A	4/1998	Mishina .....	386/106
5,289,451	A	2/1994	Ashinuma et al. ....	369/58	5,870,523 A	2/1999	Kikuchi et al. ....	386/95
5,315,570	A	5/1994	Miura et al. ....	369/48	6,075,920 A	6/2000	Kawamura et al. ....	386/95
5,436,878	A	7/1995	Yamaguchi et al. ....	369/47	6,167,189 A	12/2000	Taira et al. ....	386/95
5,592,450	A	1/1997	Yonemitsu et al. ....	369/48	6,192,190 B1 *	2/2001	Tojo et al. ....	386/109
5,596,565	A	1/1997	Yonemitsu et al. ....	369/275.3	6,370,102 B1 *	4/2002	Mons et al. ....	369/94
5,608,715	A *	3/1997	Yokogawa et al. ....	369/275.1	6,442,334 B1	8/2002	Kawamura et al. ....	386/95

\* cited by examiner

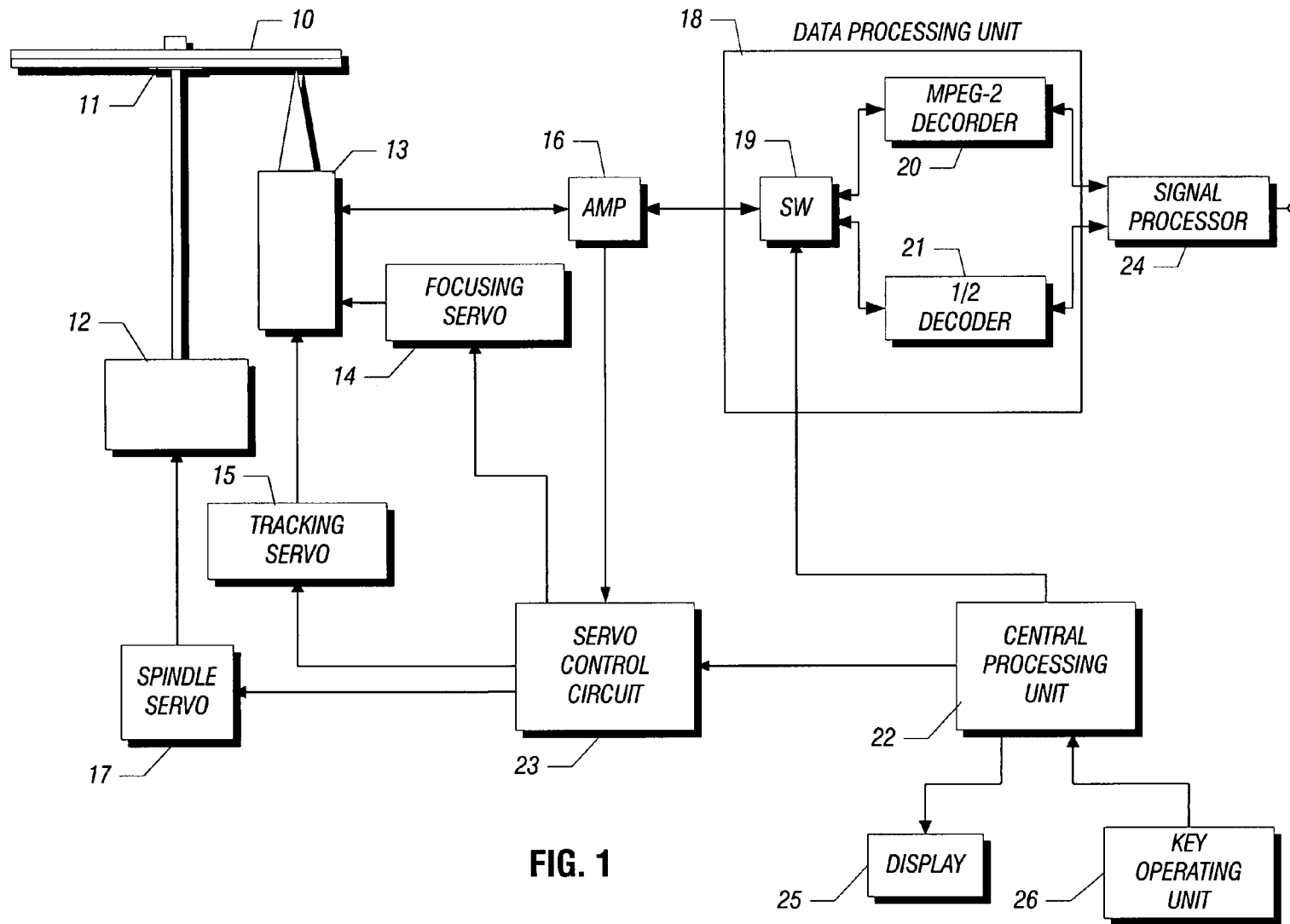

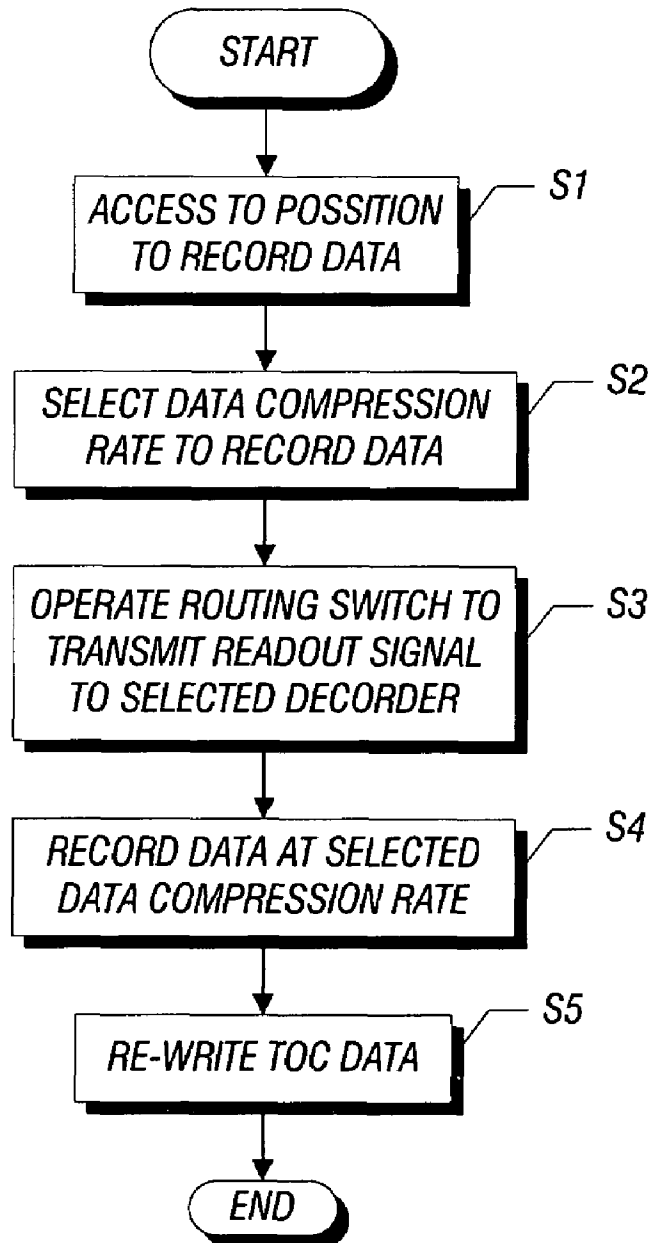

FIG. 2

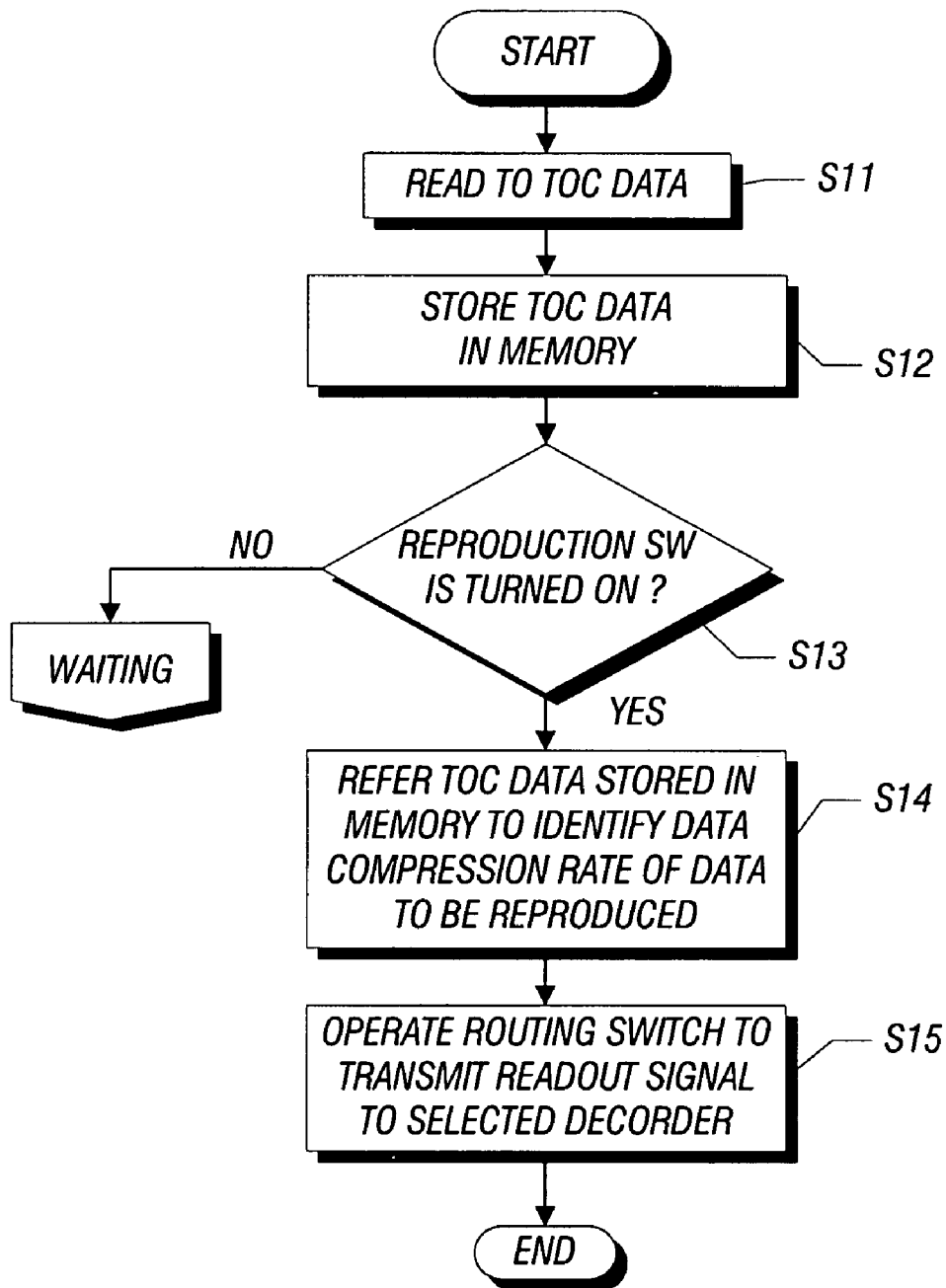

FIG. 3

US 7,116,629 B2

1

## DATA RECORDING AND REPRODUCING METHOD FOR MULTI-LAYERED OPTICAL DISK SYSTEM

The application is continuation of U.S. application Ser. No. 09/949,689, filed Sep. 10, 2001, now U.S. Pat. No. 6,529,469, which is a continuation U.S. application Ser. No. 09/670,890, filed Sep. 28, 2000, U.S. Pat. No. 6,339,568, which is a divisional of U.S. application Ser. No. 09/370,308, filed Aug. 9, 1999, now U.S. Pat. No. 6,215,743, which is a continuation of U.S. application Ser. No. 08/720,531, now U.S. Pat. No. 5,982,723.

### BACKGROUND OF THE INVENTION

#### 1. Field of the Invention

This invention relates to an optical data recording and reproducing method. More specifically, this invention relates to an optical disk recording and reproducing method which makes possible to record data encoded by different encoding circuit at different data compression rate and to reproduce the data.

#### 2. Description of the Prior Art

Initialized by the vast increase in information that needs to be processed, optical data storage system having become very important system particularly because of their high storage density per area. Most of the recent optical information storage systems rotating single optical disk are used on which the information is digitally stored in concentric circular tracks in an ordered, predefined manner to allow chronological fast reading and fast random access to desired pits of data.

In order to accomplish even more storage capacity of optical disk systems for enormous information processing, such as video or picture communication like so called video-on-demand service, multiple disk systems have been proposed. An optical disk system equipped with two or more data layers may in theory be accessed as different disks by changing the focal point with moving lens. Example of this type of state-of-the-art include U.S. Pat. No. 5,202,875 issued Apr. 13, 1993 to Rosen et al.; Japanese Published Application, 63-276732 published Nov. 15, 1988 by Watanabe, et al.

Such a multiple disk recording and reading system is applied to varied optical disk information storage systems. For example, a digital video disk (DVD) system for home entertaining is one of the typical application. The mentioned advantage of vast storage capacity may contribute especially for video signal transmission. In order to record the video data efficiently onto the optical disk, a video data compression technique is one of the key technologies. A standardized video data compression rate has been proposed, which is called MPEG (Moving Picture Experts Group). However, for the home entertaining purposes, a more flexible function is required. The ability to record data at different data compression rates and to reproduce the recorded data, must be provided.

### 3. SUMMARY OF THE INVENTION

The present invention has for its object to provide a multi-layered optical disk recording and reproducing system which is able to record data encoded by different encoding circuits at different data compression rates and to reproduce the data by a selected decoding circuit.

The object of the present invention can be achieved by an optical data recording and reproducing method, the record-

2

ing method comprising the steps of: loading a multi-layered optical disk which has M data layers (wherein M is an integer greater than 1), receiving an operator's signal to record data on an Nth data layer of the multi-layered optical disk at a certain data compression rate (wherein N is an integer greater than 1 and not greater than M), operating a routing circuit to transmit the data to a determined encoding circuit in order to compress the data at a predetermined data compression rate, recording the data on predetermined position at the predetermined data compression rate, and rewriting table of contents (TOC) data to record data about the data compression rate of the newly recorded data.

And the object of the present invention also can be achieved by an optical data recording and reproducing method, the reproducing method comprising the steps of: loading a multi-layered optical disk, which has M data layers (wherein M is an integer greater than 1), reproducing a table of contents (TOC) data recorded in the multi-layered optical disk, storing the reproduced TOC data in a memory, receiving an operator's signal to reproduce selected data stored in the multi-layered optical disk, referring to the TOC data stored in the memory to identify the data compression rate of the selected data, and operating a routing circuit to transmit a readout signal of the selected data to the determined encoding circuit in order to decompress the selected data.

For a fuller understanding of the nature and advantages of the present invention, reference should be made to the following detailed description taken in conjunction with the accompanying drawings.

### 4. BRIEF DESCRIPTION OF THE DRAWINGS

FIG. 1 shows a block diagram of an example of an optical data recording and reproducing apparatus to which the present invention can be applied;

FIG. 2 shows a flowchart for a description of an optical recording method of the present invention; and

FIG. 3 shows a flowchart for a description of an optical disk reproducing method of the present invention.

### 5. DETAILED DESCRIPTION OF THE PREFERRED EMBODIMENT

Embodiments of the present invention will be explained with reference to the drawings.

FIG. 1 shows a block diagram of a first example of an optical data recording and reproducing apparatus to which the present invention can be applied. A digital video disk (DVD) **10** which has more than two data layers is mounted on and secured by a turntable **11** to be rotated by a spindle motor **12**. Encoded pits on the DVD **10** are read by a pickup **13** which includes a laser diode, a focusing lens, a focusing lens actuator, a tracking actuator and a photo-detector. The movement of the pick-up **13** is controlled by a focusing servo circuit **14** and a tracking servo circuit **15**.

To reproduce data encoded on the DVD **10**, the output signal from the pickup **13** is transmitted to an amplifier **16**. According to a focusing error signal, the focusing servo circuit **14** modulates the focusing lens actuator to move the focal point of the laser beam emitted from the laser diode by moving the focusing lens, to access one of the data layer of the DVD **10**. And according to a tracking error signal, the tracking servo circuit **15** modulates the tracking actuator to control position of the pickup **13**. The spindle servo circuit **17** modulates the spindle motor **12** in order to track linear velocity of the DVD **10**.

US 7,116,629 B2

3

The detected signal by the pick-up **13** is amplified by the amplifier **16**. And the amplified signal is transmitted to a data processing unit **18** which is composed of a routing switch **19**, an MPEG-2 decoder **20** and a  $\frac{1}{2}$  decoder **21**. The MPEG-2 decoder **20** is a standardized data encoding or decoding circuit for a Digital Video Disk (DVD), provided in order to encode a data signal for recording on the disk and to decode the read out signal for signal processing. The  $\frac{1}{2}$  decoder **21** is a data encoding or decoding circuit provided to encode and compress the applied data signal to half data rate of the standardized DVD format. Due to the data compression by the  $\frac{1}{2}$  decoder **21**, the quality of the data must be sacrificed in order to record longer data per recording area. However, it makes it possible to provide additional functionality and flexibility for the user. A set of TOC data encoded at a read-in region of the DVD **10**, must include the data indicative of the starting and ending position of each data portion, and the data compression rate of each data. The TOC data is reproduced right after the DVD is loaded, and then the each data reproduction is preceded by referring the TOC data. And the TOC data must be rewritten after new data is recorded.

The routing switch **19** is operated by a central processing unit (CPU) **22** according to the detected TOC data, which includes the data indicating the compression rate of each data to determine the appropriate decoding circuit. The TOC data is also transmitted to a servo control circuit **23** which modulates the focusing servo circuit **14**, the tracking servo circuit **15** and the spindle servo circuit **17**. The servo control circuit **23** modulates each servo circuit to access selected data according to the TOC data which indicates the data indicating the starting and ending positions of each encoded data portion. Then the decoded signal is transmitted to a signal processor **24** to transmit the reproduced data signal to any connected unit, such as a display system or sound system. The CPU **22** is operated by an operation signal from a key operating unit **26** which transmits all operating signals input by an operator. The CPU **22** also controls a display unit **25** to show the operating status of the operator.

To record data onto the DVD **10**, a portion of an input data signal is transmitted from the signal processor **24** to the chosen decoder in the data processing unit according to the operator's command. The input data signal is encoded by the selected decoder, then recorded by the pickup **13** which is driven by the each servo circuit and the servo control circuit **23**. After the new data is recorded on the DVD **10**, the TOC data is rewritten to store the data indicating the position and data compression rate of the newly recorded data.

In addition, by storing the data of read-in and readout position of the all recorded data as TOC data, a capability of quick random access to any data portion is provided for the data reproduction process. For example, in order to reproduce one data and another data continuously, the pick-up head can rapidly switch access from readout region of the first data to the read-in region of the second data, if data as to all of the read-in region's position is stored and recorded in the TOC data. In the prior art system, all of the read-in region of the data between the first and second data must be counted by detecting the readout signal. For example, in order to reproduce both a 4<sup>th</sup> data element and a 14<sup>th</sup> data element recorded on the disk, the pick-up must detect and count ten read-in regions of the data between 4<sup>th</sup> and 14<sup>th</sup> data regions by moving the pick-up all over the disk. The present invention can provide the advantage of reproducing the data continuously without timelag. The advantage may

4

contribute remarkably to the multi-layered optical disk reading systems which is equipped with more than two data layers.

**FIG. 2** shows a flowchart of operation processing in a central processing unit (CPU), while recording data onto one data layer of a multi-layered optical disk. After a multi-layered optical disk which has M data layers (wherein M is an integer greater than 1) is loaded, the CPU receives an operator's signal to record data on the Nth data layer of multi-layered optical disk (wherein N is an integer greater than 1 and not greater than M). The CPU operates a servo control circuit to dispose a pick-up in order to access read-in region of the data to be recorded (**Step 1: S1**). According to the operator's selection of a data compression rate (**S2**), the CPU operates a routing circuit to transmit the data the determined encoding circuit in order to compress the data at the selected data compression rate (**S3**). The CPU operates a servo control circuit to record the data on a predetermined position at the predetermined data compression rate (**S4**). After the data recording is completed, the CPU operates a servo control circuit to rewrite a table of contents (TOC) data to record data indicating the data compression rate of the newly recorded data (**S5**).

**FIG. 3** shows a flowchart of an operation processing with reference to the CPU, while reproducing data which is recorded by the procedure described in **FIG. 2**. After a multi-layered optical disk which has M data layers, wherein M is an integer greater than 1, is loaded, the CPU operates the servo control circuit to reproduce table of contents (TOC) data recorded in the multi-layered optical disk (**S11**). Then the CPU stores the reproduced TOC data in a memory (**S12**). When the CPU receives an operator's signal to reproduce certain data from the optical disk (**S13**), the CPU refers to the TOC data stored in the memory to identify the data compression rate of the selected data (**S14**). Then the CPU operates the routing switch to transmit a readout signal of the selected data to a determined encoding circuit in order to decompress the selected data (**S15**). After all of these procedures are completed, the data reproduction is started.

Although the invention has been particularly shown and described, it is contemplated that various changes and modification may be made without departing from the scope of the invention as set forth in the following claims.

What is claimed is:

1. An optical disk defining a multi-layered recording region and a table of contents data set region on a first data layer for all data recorded in the multi-layered recording region, the table of contents data set region storing:
  - first control data indicative of a data compression technique associated with data recorded in the multi-layered recording region;
  - second control data indicative of a location of the data recorded in the multi-layered recording region; and
  - third control data indicative of data layer information for the data recorded in the multi-layered recording region.
2. The optical disk of claim 1, wherein the first control data in the table of contents data set is used to specify different compression rates for all data recorded in the multi-layered recording region.
3. The optical disk of claim 1, wherein the second control data indicates a starting position and an ending position of the data recorded in the multi-layered recording region.
4. The optical disk of claim 1, wherein the data layer information indicates whether the data layer is a recordable layer.



## US 7,116,629 B2

5

5. The optical disk of claim 1, wherein the table of contents data set region is stored in a read-in region of the optical disk.

6. An optical disk defining a multi-layered recording region and a control data region on a first data layer containing control data for all data recorded in the multi-layered recording region, the control data storing:

first control data indicative of a data compression technique associated with data recorded in the multi-layered recording region;

second control data indicative of a location of the data recorded in the multi-layered recording region; and  
third control data indicative of a layer number of the data recorded in the multi-layered recording region.

7. The optical disk of claim 6, wherein the control data region comprises a table of contents data set.

8. The optical disk of claim 6, wherein the second control data indicates a starting position and an ending position of the data recorded in the multi-layered recording region.

9. The optical disk of claim 6, wherein at least some of the control data is stored in a read-in region of the optical disk.

10. A multi-layered optical disk comprising a read-in region on a first data layer containing a control data set for all data layers in the optical disk, the control data set comprising:

first control data indicative of a data compression technique of recorded data stored in a recording region of the optical disk;

second control data indicative of a location of the recording region wherein the recorded data is stored; and  
third control data indicative of a layer number of the recording region wherein the recorded data is stored.

11. The optical disk of claim 10, wherein at least the first control data and second control data are stored in a table of contents data set region on the first data layer of the optical disk.

12. An optical disk defining a multi-layered recording region therein, the optical disk storing:

first control data indicative of a number of data layers of the optical disk;

second control data indicative of a layer number of the data recorded in the multi-layered recording region;  
third control data indicative of a data compression technique associated with data recorded in the multi-layered recording region; and

fourth control data indicative of a location of the data recorded in the multi-layered recording region;

where at least the third and fourth control data for all data recorded in the multi-layered recording region are stored on a first data layer of the multi-layered optical disk.

13. The optical disk of claim 12, where at least the third and fourth control data for all data recorded in the multi-layered recording region are stored in a table of contents data set region located on a first data layer of the multi-layered optical disk.

14. The optical disk of claim 12, wherein the fourth control data indicates a starting position and an ending position of the data recorded in the recording region.

15. The optical disk of claim 12, wherein at least some of the control data is stored in a read-in region of the optical disk.

16. A multi-layered optical disk comprising a first data layer containing a control data set for all data layers in the optical disk, the control data set comprising:

6

first control data indicative of a data compression technique of recorded data stored in a recording region of the optical disk;

second control data indicative of a location of the recording region wherein the recorded data is stored;

third control data indicative of a number of data layers of the optical disk; and

fourth control data indicative of a layer number of the recording region wherein the recorded data is stored.

17. The optical disk of claim 16, wherein at least some of the control data is stored in a read-in region of the optical disk.

18. An optical disk defining a multi-layered recording region and a first data layer containing a read-in region and a table of contents data set for all data layers in the optical disk, the first data layer comprising:

first control data indicative of a location of the recording region;

second control data indicative of a location of a data recording portion in the recording region;

third control data indicative of a number of data layers of the optical disk;

fourth control data indicative of a layer number of the data recording portion; and

fifth control data indicative of a data compression technique of data recorded in the data recording portion.

19. The optical disk of claim 18, wherein the first control data indicative of the location of the recording region is associated with the second control data indicative of the location of the data recording portion.

20. A multi-layered optical disk defining a multi-layered recording region, a read-in region for the multi-layered optical disk and a table of contents region on a first data layer containing control data for all data layers of the recording region, the optical disk comprising:

first control data indicative of a location of the recording region;

second control data indicative of a location of a data recording portion in the recording region;

third control data indicative of a number of data layers of the optical disk;

fourth control data indicative of a layer number of the data recording portion; and

fifth control data region to store a data compression technique of recording data.

21. The optical disk of claim 20, wherein at least the third control data is stored in the read-in region.

22. A digital video disk defining a multi-layered recording region and a single layer for recording compression rate and location information for all data recorded in the multi-layered recording region, the single layer comprising:

first control data indicative of a location of the recording region;

second control data indicative of a location of a data recording portion in the recording region wherein recorded data is stored;

third control data indicative of a number of data layers of the digital video disk;

fourth control data indicative of a layer number of the data recording portion wherein the recorded data is stored; and

fifth control data indicative of a data compression technique of the recorded data.

23. The digital video disk of claim 22, wherein at least some of the control data is stored in a table of contents region.



US 7,116,629 B2

7

24. An optical disk defining a multi-layered recording region and a control data region on a first data layer containing control data for all data recorded in the multi-layered recording region, the control data comprising:

first control data indicative of a data compression technique associated with data recorded in the multi-layered recording region;

second control data indicative of a location of the data recorded in the multi-layered recording region; and

third control data indicative of a number of layers of the optical disk.

25. The optical disk of claim 24, wherein the control data region comprises a table of contents data set.

26. The optical disk of claim 24, wherein the second control data indicates a starting position and an ending position of the data recorded in the multi-layered recording region.

27. The optical disk of claim 24, wherein at least the third control data is stored in a read-in region of the optical disk.

28. A multi-layered optical disk comprising a read-in region on a first data layer containing a control data set for all data layers in the optical disk, the control data set comprising:

first control data indicative of a data compression technique of recorded data stored in a recording region of the optical disk;

second control data indicative of a location of the recording region wherein the recorded data is stored; and

8

third control data indicative of a number of layers of the multi-layered optical disk.

29. The optical disk of claim 28, wherein at least the first control data and second control data are stored in a table of contents data set region on the first data layer of the optical disk.

30. The optical disk of claim 28, wherein at least the third control data is stored in a read-in region of the multi-layered optical disk.

31. A multi-layered optical disk containing a read-in region in a first data layer having a table of contents data set for a plurality of data sets stored in one or more data layers in the optical disk, where each data set is compressed at a different data compression rate, said table of contents data set comprising:

first control data indicative of a location of each stored data set;

second control data indicative of a number of data layers of the optical disk;

third control data indicative of a layer number of each stored data set; and

fourth control data indicative of a data compression technique of each stored data set.

32. The optical disk of claim 31, wherein the first control data identifies a starting and ending position for each stored data set.

\* \* \* \* \*