

**IN THE UNITED STATES DISTRICT COURT
FOR THE NORTHERN DISTRICT OF ILLINOIS
EASTERN DIVISION - CHICAGO**

**COLUMBIA SPORTSWEAR NORTH
AMERICA, INC.**, an Oregon corporation,

Plaintiff,

v.

TEAM ORTHO FOUNDATION, INC., a
Minnesota non-profit organization,

Defendant.

Case No.: 1:16-cv-01052

JURY TRIAL REQUESTED

**COMPLAINT FOR PATENT INFRINGEMENT, COPYRIGHT INFRINGEMENT,
TRADE DRESS INFRINGEMENT, UNFAIR COMPETITION, FALSE DESIGNATION
OF ORIGIN, AND DECEPTIVE TRADE PRACTICES**

Plaintiff, Columbia Sportswear North America, Inc. (“Columbia Sportswear”), brings this Complaint against Defendant Team Ortho Foundation, Inc. (“Team Ortho”), and alleges as follows:

1. Plaintiff is a part of the Columbia Sportswear family of companies (the “Columbia Sportswear Group”) that designs, manufactures, advertises, markets, promotes and sells, directly and through authorized retailers, various kinds of clothing and accessories (including outerwear, sportswear, footwear, headgear, camping equipment, skiwear and sleeping bags) under the COLUMBIA® brand throughout the world.

NATURE OF THE ACTION

2. This is an action for patent infringement, copyright infringement, trade dress infringement, unfair competition, false designation of origin, and violation of applicable state statutory and common law. The action arises under the federal Patent Act, 35 U.S.C. §§ 101 *et seq.*; the federal Copyright Act, 17 U.S.C. §§ 101 *et seq.*; the federal Lanham Act, 15 U.S.C. §§ 1051 *et seq.*; and Illinois’ Uniform Deceptive Trade Practices Act, 815 ILCS §§ 510/1 *et seq.*

3. This lawsuit pertains in part to Team Ortho’s infringement of Columbia

Sportswear's U.S. Patent No. D650,529 (the "529 Patent"), a copy of which is attached as Exhibit 1; U.S. Patent No. D670,435 (the "435 Patent"), a copy of which is attached as Exhibit 2; U.S. Patent No. 8,424,119 (the "119 Patent"), a copy of which is attached as Exhibit 3; and U.S. Patent No. 8,453,270 (the "270 Patent"), a copy of which is attached as Exhibit 4 (collectively, the "Columbia Sportswear Patents"). Collectively, these patents protect Columbia Sportswear's widely-recognized Omni-Heat® technology, a proprietary heat reflective material that regulates temperature by retaining body heat and also provides other desirable features, such as breathability and moisture wicking. This innovative material is featured as a lightweight lining in body gear such as jackets, shirts, gloves, socks and headwear sold under the COLUMBIA® brand.

4. This lawsuit also pertains to Team Ortho's infringement of certain copyright rights belonging to Columbia Sportswear in its marketing materials and images (the "Columbia Sportswear Copyrights") that Columbia Sportswear uses to promote and market its Omni-Heat products.

5. This lawsuit also pertains to Team Ortho's infringement of trade dress carefully developed by the Columbia Sportswear Group. Since 2010, the Columbia Sportswear Group has manufactured, used, advertised, marketed, promoted, offered for sale and sold in the United States various products, including various items of apparel, with a silver colored dot pattern (the "Silver Dot Trade Dress"). This distinctive silver-colored dot pattern, which has been used consistently on products featuring Columbia Sportswear's Omni-Heat technology, has come to be associated exclusively with the COLUMBIA® brand and its products and distinguishes its products from those manufactured and sold by others. Through dedicated and consistent presentation of the Silver Dot Trade Dress—emphasized by the use of such "look for" promotional language as "Magic in a Little Silver Dot"—the Columbia Sportswear Group has developed a reputation and acquired substantial goodwill in the Silver Dot Trade Dress. Hence, this lawsuit pertains in part to Team Ortho's infringement of the Silver Dot Trade Dress under the Lanham Act and Illinois' Uniform Deceptive Trade Practices Act.

6. Team Ortho is flagrantly using the Columbia Sportswear Patents, the Columbia Sportswear Copyrights and the Silver Dot Trade Dress, without Columbia Sportswear's permission, on cold weather athletic pullovers that Team Ortho makes, has made, uses, offers for sale, sells and/or imports into the United States, including in Chicago, Illinois.

7. Columbia Sportswear seeks, among other relief, an injunction preventing Team Ortho from further infringing the Columbia Sportswear Patents, the Columbia Sportswear Copyrights and the Silver Dot Trade Dress, together with damages and/or disgorgement of Team Ortho's profits from its infringing activity and attorneys' fees and costs.

THE PARTIES

8. Plaintiff Columbia Sportswear North America, Inc. is a corporation organized and existing under the laws of the State of Oregon, with its principal place of business located in Portland, Oregon. Columbia Sportswear North America, Inc. is a wholly-owned subsidiary of Columbia Sportswear Company, a corporation organized and existing under the laws of the State of Oregon, with its principal place of business in Portland, Oregon. Columbia Sportswear North America, Inc. owns the Columbia Sportswear Patents, the Columbia Sportswear Copyrights, and the Silver Dot Trade Dress used in connection with Omni-Heat products sold under the COLUMBIA® brand.

9. On information and belief, Team Ortho is a Minnesota non-profit organization having a principal place of business located in Minneapolis, Minnesota.

JURISDICTION AND VENUE

10. Columbia Sportswear's causes of action for patent infringement, copyright infringement, and Lanham Act violations against Team Ortho arise under the laws of the United States, including 35 U.S.C. § 101 *et seq.*, 17 U.S.C. §§ 101 *et seq.*, and 15 U.S.C. §§ 1051 *et seq.* This Court has original jurisdiction over this subject matter pursuant to 28 U.S.C. §§ 1331, 1332, and 1338(a) and 15 U.S.C. § 1121(a). The Court has supplemental jurisdiction over Columbia Sportswear's state law claims pursuant to 28 U.S.C. § 1367.

11. This Court has personal jurisdiction over Team Ortho because it transacts and solicits business in the State of Illinois, including with respect to the infringing products at issue in this case, and because Team Ortho is committing and has committed acts of infringement in this district by selling, offering to sell and using infringing products in this district, including in Chicago, Illinois, and by inducing retailers to distribute its infringing products in this district. In connection with its distribution and sale of products that infringe the Columbia Sportswear Patents and the Silver Dot Trade Dress, Team Ortho has also reproduced, publicly displayed and distributed promotional materials and images in this district which infringe the Columbia Sportswear Copyrights. Further, Team Ortho maintains an Internet site available to consumers within this district on which it advertises its products and hosts an interactive function whereby users can order Team Ortho products for pick-up at a nearby location or—for an additional fee—to be mailed to them directly. Most recently, Team Ortho directed sales of the infringing products through its Internet site to consumers within this district in connection with the “Polar Dash” races held in Chicago on January 9, 2016, as described further below.

12. Venue is proper in this judicial district under 28 U.S.C. §§ 1391(b) & (c) and 1400(a) & (b) because Team Ortho regularly transacts and solicits business in this district, including with respect to the infringing products at issue in this case, and because Team Ortho is committing and has committed acts of infringement in this district by selling, offering to sell, using and distributing products in this district that infringe upon the Columbia Sportswear Patents and the Silver Dot Trade Dress, and by reproducing, displaying and distributing promotional materials within this judicial district that infringe upon the Columbia Sportswear Copyrights.

FACTUAL BACKGROUND

Columbia Sportswear and its Proprietary Technology

13. Columbia Sportswear is a leading innovator in the global outdoor apparel, footwear, accessories and equipment markets. Founded in 1938, Columbia Sportswear apparel, footwear, accessories and outdoor equipment have earned a reputation for innovation, quality

and performance, serving the needs of outdoor enthusiasts in more than 100 countries.

A. The Columbia Sportswear Patents

14. Columbia Sportswear has taken steps to protect its innovations and designs, including those surrounding its well-known Omni-Heat technology. Relevant to this case, Columbia Sportswear owns all right, title, and interest in the '529 Patent, entitled "PATTERNED HEAT REFLECTIVE MATERIAL," which covers the ornamental design for the heat reflective material as shown and described in the figures incorporated into the '529 Patent. Figures 1 and 4 of the '529 Patent, which show a perspective view and elevational view of the heat reflective material, are shown below:

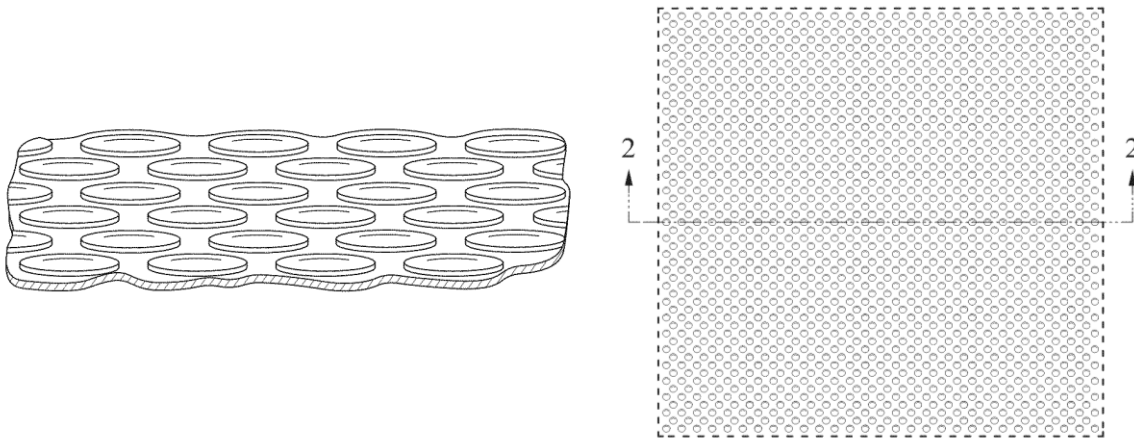
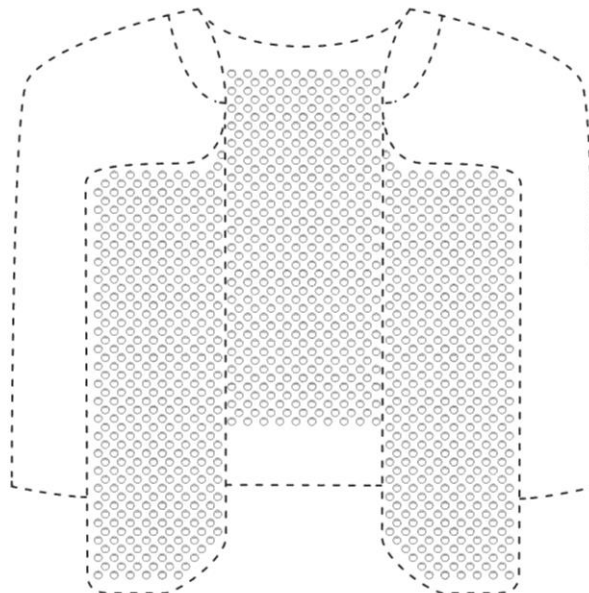
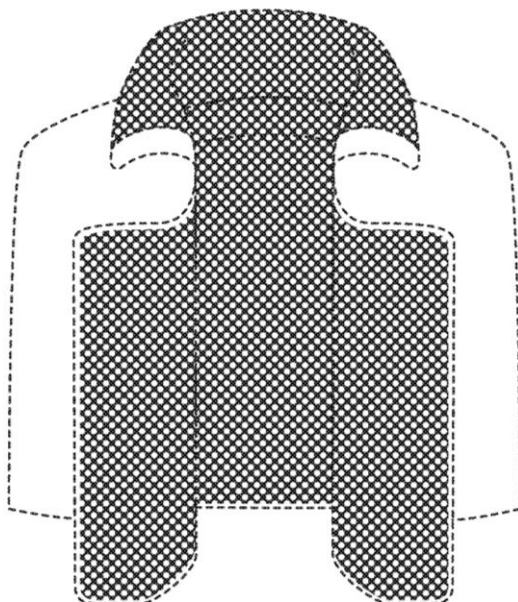

Figure 3 of the '529 patent shows the heat reflective material as used in a jacket:



15. Columbia Sportswear also owns all right, title, and interest in the '435 Patent, entitled "HEAT REFLECTIVE MATERIAL WITH PATTERN," which covers the ornamental design for the heat reflective material as shown and described in the figures incorporated into the '435 Patent. Figure 2 of the '435 Patent, which shows the heat reflective material as used in a jacket, is shown below:



16. Columbia Sportswear also owns all right, title, and interest in the '119 Patent, entitled "PATTERNED HEAT MANAGEMENT MATERIAL," which is directed to body gear using an array of heat managing elements coupled to a base material to direct body heat while also maintaining desirable transfer and other functional properties of the base material. Figure 1A of the '119 Patent depicts use of the heat management material in a jacket:

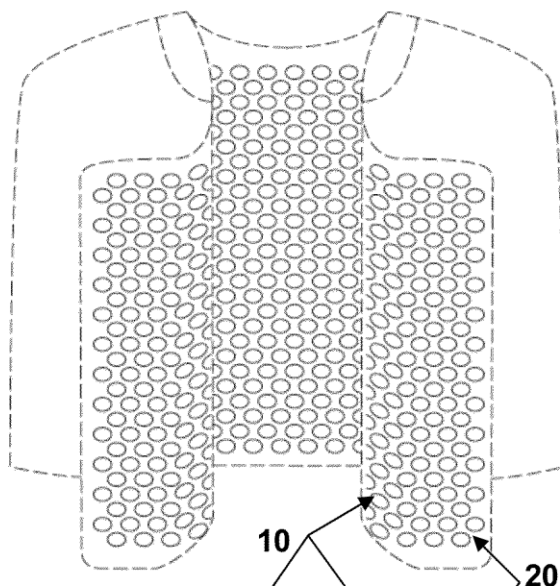

17. Columbia Sportswear also owns all right, title, and interest in the '270 Patent, entitled "PATTERNED HEAT MANAGEMENT MATERIAL," which, like the '119 Patent, is directed to body gear using an array of heat managing elements coupled to a base material to direct body heat while also maintaining desirable transfer properties of the base material. Like the '119 Patent, Figure 1A of the '270 Patent depicts use of the heat management material in a jacket:

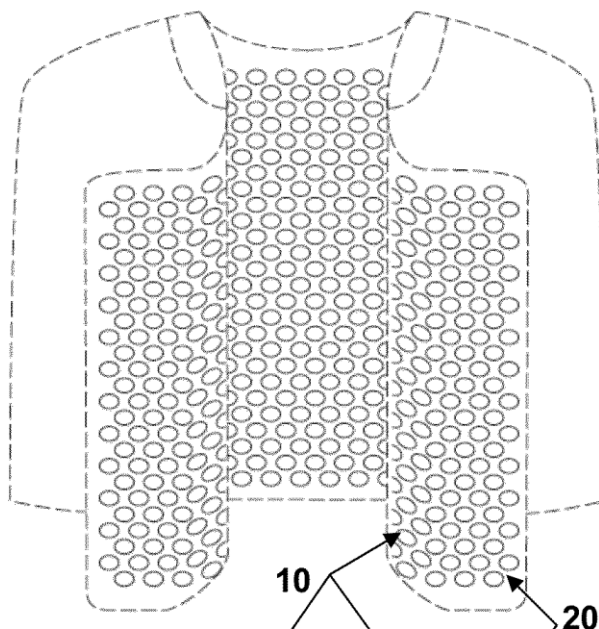

B. The Silver Dot Trade Dress

18. The evenly-distributed, small silver dot pattern used on COLUMBIA®-branded Omni-Heat products—the Silver Dot Trade Dress—is arbitrary and inherently distinctive. The overall design of the Silver Dot Trade Dress is non-functional, as demonstrated, for example, by the number of alternative design configurations disclosed in the '119 and '270 Patents, each of which could perform equally well the heat retention, breathing, and moisture-wicking functions of the Omni-Heat technology. Several such embodiments are pictured in Figures 2A-B and 3A-E of the '119 and '270 Patents, reproduced below.

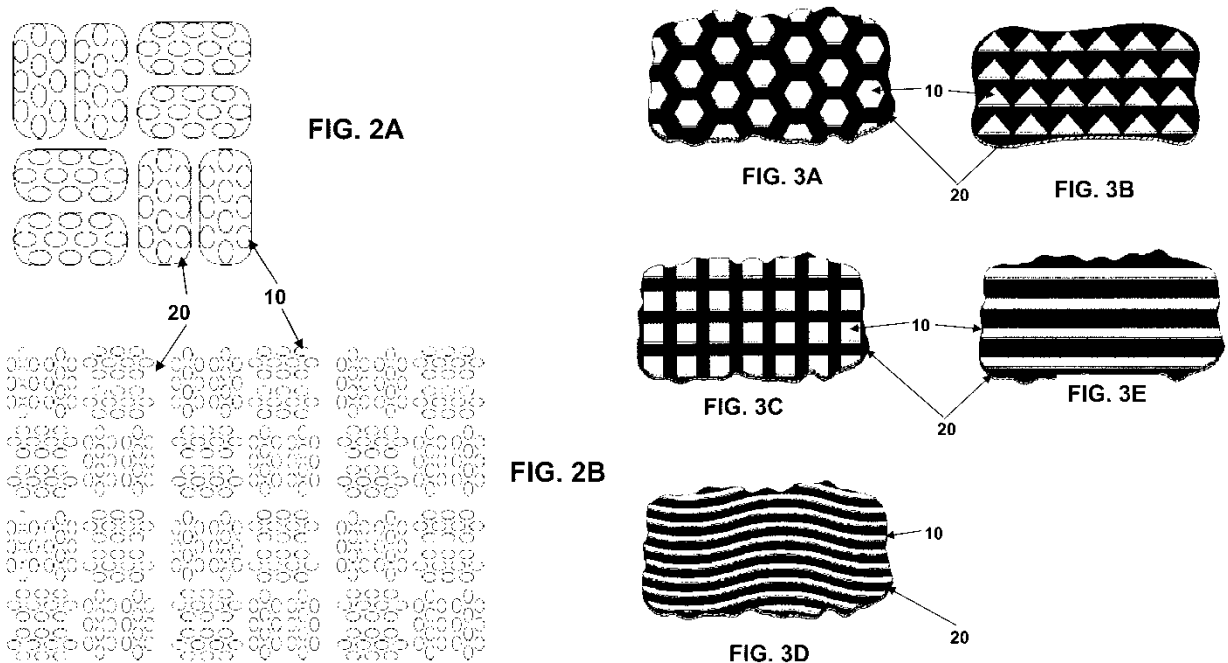

19. Supported by its portfolio of design and utility patents, since at least as early as 2010, the Columbia Sportswear Group has been the exclusive source of Omni-Heat products featuring the Silver Dot Trade Dress, and currently offers hundreds of distinct products featuring the Silver Dot Trade Dress, including shirts, jackets, headwear, gloves, socks, sleeping bags, and a variety of other products.

20. As a result of its longstanding, continuous and exclusive use, the Columbia Sportswear Group has built up valuable recognition and goodwill in its distinctive Silver Dot

Trade Dress. The Columbia Sportswear Group has expended, and continues to expend, substantial time, effort, money, and other resources to develop and maintain the valuable goodwill that has come to be associated with Omni-Heat products incorporating the unique and recognizable Silver Dot Trade Dress.

21. The Columbia Sportswear Group has continuously and extensively advertised, marketed and promoted its Omni-Heat products in the United States and around the world, investing substantial sums in such activities, including advertising directed to the distinctive, non-functional aspects of the appearance of Omni-Heat products, such as its widely-used marketing slogan, “Magic in a Little Silver Dot.”

22. As a result of the Columbia Sportswear Group’s efforts, the Silver Dot Trade Dress has acquired secondary meaning and distinctiveness among outdoor and athletic enthusiasts and members of the industry, and it continues to have secondary meaning and distinctiveness. Omni-Heat products displaying the Silver Dot Trade Dress are now widely known and recognized by their unique, ornamental and distinctive appearance, which identifies to sportswear consumers and industry members that their source of origin is the Columbia Sportswear Group and its COLUMBIA® brand.

23. Based on the foregoing, the Silver Dot Trade Dress has become and now is a designation of origin of Columbia Sportswear.

C. The Columbia Sportswear Copyrights

24. Columbia Sportswear has taken steps to protect its original works of authorship, including the technical graphics, text, images and associated online works it uses to market and promote its well-known Omni-Heat technology, including but not limited to the works displayed in paragraphs 29 and 30, *infra*, of this Complaint. Those works are the subject of copyright applications filed with the U.S. Copyright Office.

Team Ortho and its Infringing Activities

25. Team Ortho produces foot racing events in this district, including the “Chicago Polar Dash” in January, the “Chicago Get Lucky” run in March, the “Chicago Tiki Run” in June,

the “Chicago Women ROCK” run in September and the “Chicago Monster Dash” on Halloween. Team Ortho produces similar running events in Minneapolis and Dallas/Fort Worth.

26. On information and belief, at its most recent running event in this district, the “Chicago Polar Dash,” and at other running events it produces, Team Ortho sells, offers to sell, uses and induces others to use athletic pullovers under its own brand that incorporate a lining with reflective material as shown below:

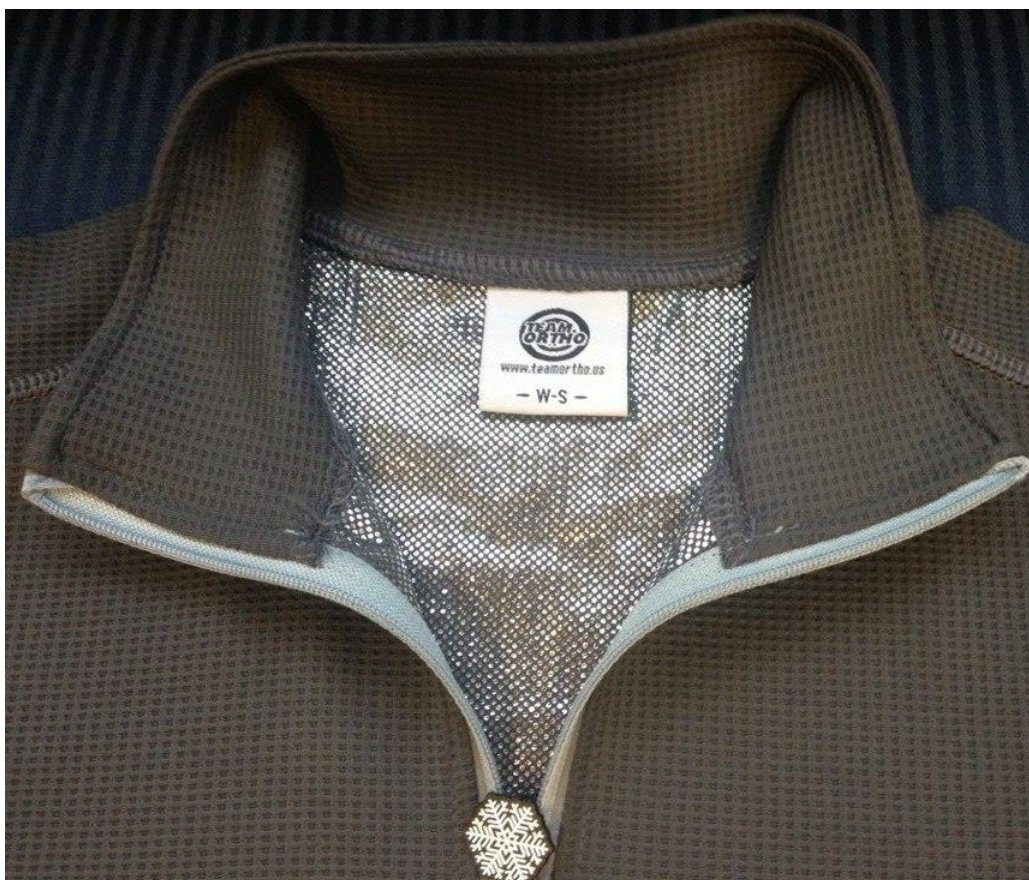

27. In the everted and close-up images below, the pullover’s heat-reflective lining is clearly visible:



28. The pullover's heat-reflective lining as pictured in paragraph 27, *supra*, infringes the Columbia Sportswear Patents and the Silver Dot Trade Dress.

29. Removing any doubt that Team Ortho's infringement of the Columbia Sportswear Patents and the Silver Dot Trade Dress was and is willful, the advertising hang tags attached to the Team Ortho pullover distributed at the "Chicago Polar Dash" includes an identical technical graphic and verbatim copy of the marketing materials used by Columbia Sportswear to promote its genuine Omni-Heat products, and even goes so far as to include Columbia Sportswear's Omni-Heat slogan, "Magic in a Little Silver Dot." Specifically, the hang tag attached to the infringing products reads:

- (1) This breathable warming technology helps regulate your temperature with little silver dots that reflect and retain the warmth your body generates.
- (2) **Features**
 - Reflects body heat
 - Highly breathable
 - Reduces your need for bulky layers
 - Wicks moisture to keep you dry and comfortable

The hang tag also clearly displays Columbia Sportswear's own graphic used to illustrate the

technical features of Columbia Sportswear's Omni-Heat technology, as shown below:



30. By way of comparison, reproduced below is an image from Columbia Sportswear's website containing the slogan, "Magic in a Little Silver Dot," also juxtaposed with a picture of the Silver Dot Trade Dress. This image is viewable at <http://www.columbia.com/technology-omniheatreflective/>.

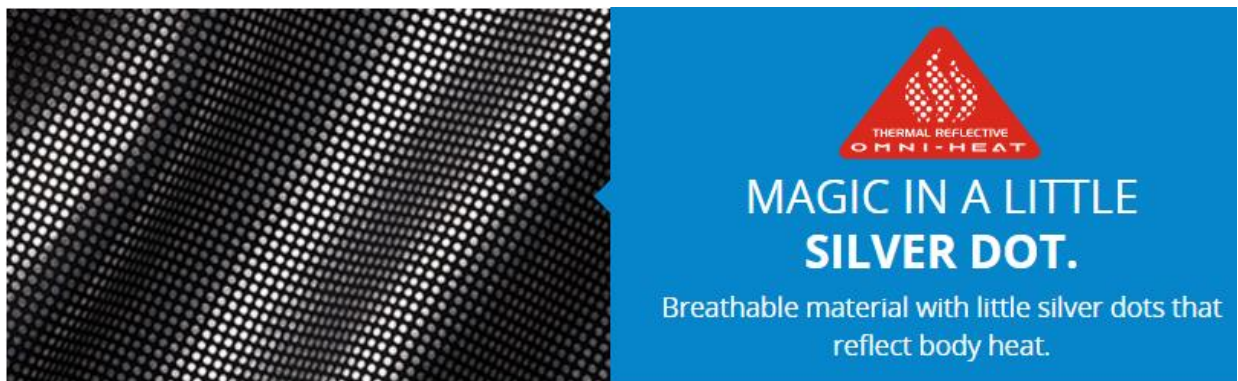

31. Reproduced below is another image from Columbia Sportswear’s website which contains the exact language – word for word – that Team Ortho copied and included on the hang tag attached to its infringing products. This image from Columbia Sportswear’s website is viewable at <https://www.columbia.com/technology-landing.html> and can be accessed by clicking the bar labeled “Omni-Heat™ Reflective.”

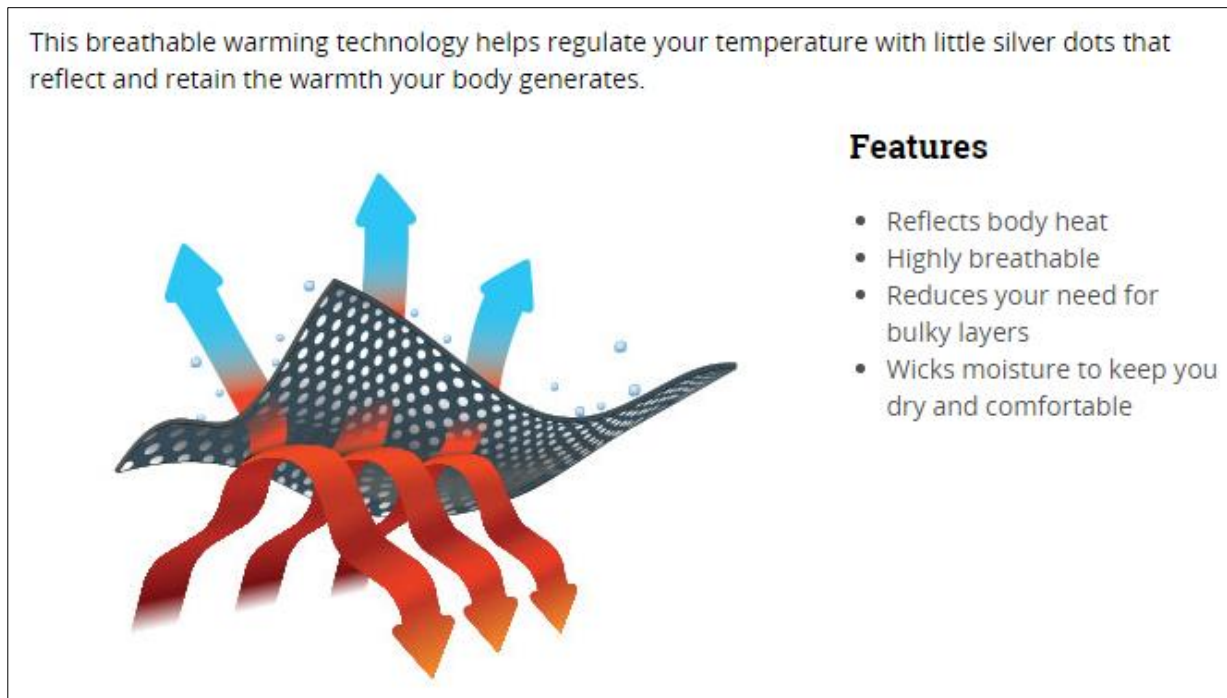

32. On information and belief, Team Ortho imports, sells, offers to sell, uses, and induces others to use its infringing pullovers and other running gear to participants in foot race events that Team Ortho produces in Chicago and other cities around the country.

33. Team Ortho promotes these events months in advance, inducing runners to pay registration fees of anywhere from \$24.99 to \$119.99.

34. According to Team Ortho’s website, over 265,000 people have participated in its races over the last five years.

35. On information and belief, in exchange for their “registration fees,” in addition to being permitted to run the race, participants in Team Ortho events receive a “packet” of running

gear that include the infringing pullovers, as well as hats, jackets, sweatshirts, and/or other sportswear.

36. Team Ortho actively markets its sportswear on its website with images and other promotional material. For example, the following language is viewable at <http://www.teamortho.us/about-us.html>:

Team Ortho Foundation is known for its great gear. Tell me about it.
Team Ortho Foundation believes that runners who look good also feel good so we strive to design gear that is durable, safe, high performing and attractive. Our gear is quality gear, meant for four seasons, and is made with performance fabrics that often use reflectivity for safety. Much of apparel comes from China and from the same factories used to make the best quality American brands. Our dedication to quality does require us to make business trips to China to meet with the factories and ensure our standards are consistently met as well as ensure timely delivery of gear in time for our races. Many runners comment on the quality of our gear and it is part of our value offering to runners. We believe that over time, useful high-quality apparel reduces the cost barriers to year-round running.

37. On information and belief, Team Ortho invites participants to pick up their packets at a local retailer, or, for an additional fee of \$29.99, Team Ortho will mail the running gear directly to the registrant.

38. For example, in the case of the “Polar Dash” races held in Chicago on January 9, 2016, participants retrieved their packets from the Sports Authority store located at 3134 North Clark Street in Chicago.

39. Columbia Sportswear obtained the infringing pullover pictured herein from a participant in the January 9, 2016 “Polar Dash” event in Chicago, and has confirmed through analysis and testing that the pullovers’ reflective lining infringes the ’119 and ’270 Patents.

COUNT I –

INFRINGEMENT OF UNITED STATES

PATENT D650,529

40. Columbia Sportswear restates and realleges each of the allegations, photographs and figures of paragraphs 1-39 as if fully set forth herein.

41. Team Ortho has infringed the ’529 Patent within this judicial district by manufacturing or importing into, using, inducing others to use, selling and/or offering for sale

sportswear products, including but not limited to the pullover depicted herein, that embody the patented design disclosed in the '529 Patent, in violation of 35 U.S.C. §§ 271 and 289.

42. Team Ortho is not licensed or otherwise authorized by Columbia Sportswear to make, use, import, sell, or offer to sell any product with heat reflective material whose design is covered by the '529 Patent and its conduct is, in every instance, without Columbia Sportswear's consent.

43. The design of Team Ortho's infringing sportswear so closely resembles the design disclosed in the '529 Patent that an ordinary observer will perceive the overall appearance of the designs to be substantially the same.

44. On information and belief, Team Ortho intended to copy the design covered by the '529 Patent.

45. Team Ortho will continue to manufacture, import, sell, use and induce others to use its infringing sportswear unless enjoined by this Court.

46. Due to Team Ortho's infringement of the '529 Patent, Columbia Sportswear is entitled to recover from Team Ortho damages adequate to compensate for the infringement in an amount subject to proof at trial, but in no event less than a reasonable royalty, together with interest and costs as fixed by this Court under 35 U.S.C. § 284. As an alternative remedy for Team Ortho's infringement of the '529 Patent, Columbia Sportswear is entitled to recover Team Ortho's total profits from the sale of its infringing sportswear, but not less than \$250, under 35 U.S.C. § 289.

47. Due to Team Ortho's infringement of the '529 Patent, Columbia Sportswear has suffered, is suffering, and will continue to suffer irreparable injury and damage for which Columbia Sportswear has no adequate remedy at law. Columbia Sportswear is therefore entitled to a permanent injunction against Team Ortho's further infringing conduct.

COUNT II –
INFRINGEMENT OF UNITED STATES
PATENT D670,435

48. Columbia Sportswear restates and realleges each of the allegations, photographs and figures of paragraphs 1-39 and 41-47 as if fully set forth herein.

49. Team Ortho has infringed the '435 Patent within this judicial district by manufacturing or importing into, using, inducing others to use, selling and/or offering for sale sportswear products, including but not limited to the pullover depicted herein, that embody the patented design disclosed in the '435 Patent, in violation of 35 U.S.C. §§ 271 and 289.

50. Team Ortho is not licensed or otherwise authorized by Columbia Sportswear to make, use, import, sell, or offer to sell any product with heat reflective material whose design is covered by the '435 Patent and its conduct is, in every instance, without Columbia Sportswear's consent.

51. The design of Team Ortho's infringing sportswear so closely resembles the design disclosed in the '435 Patent that an ordinary observer will perceive the overall appearance of the design to be substantially the same.

52. On information and belief, Team Ortho intended to copy the design covered by the '435 Patent.

53. Team Ortho will continue to manufacture, import, sell, use and induce others to use its infringing sportswear unless enjoined by this Court.

54. Due to Team Ortho's infringement of the '435 Patent, Columbia Sportswear is entitled to recover from Team Ortho damages adequate to compensate for the infringement in an amount subject to proof at trial, but in no event less than a reasonable royalty, together with interest and costs as fixed by this Court under 35 U.S.C. § 284. As an alternative remedy for Team Ortho's infringement of the '435 Patent, Columbia Sportswear is entitled to recover Team Ortho's total profits from the sale of its infringing sportswear, but not less than \$250, under 35 U.S.C. § 289.

55. Due to Team Ortho's infringement of the '435 Patent, Columbia Sportswear has suffered, is suffering, and will continue to suffer irreparable injury and damage for which Columbia Sportswear has no adequate remedy at law. Columbia Sportswear is therefore entitled to a permanent injunction against Team Ortho's further infringing conduct.

**COUNT III –
INFRINGEMENT OF UNITED STATES**

PATENT 8,424,119

56. Columbia Sportswear restates and realleges each of the allegations, photographs and figures of paragraphs 1-39 as if fully set forth herein.

57. Team Ortho has been, and presently is, infringing the '119 Patent, literally or under the doctrine of equivalents, within this judicial district by manufacturing, importing, using, inducing others to use, selling and/or offering for sale sportswear products, including but not limited to the pullover depicted herein, that includes heat management material that embodies the patented invention disclosed in the '119 Patent, in violation of 35 U.S.C. § 271.

58. Team Ortho is not licensed or otherwise authorized by Columbia Sportswear to manufacture, import, use, induce others to use, sell and/or offer for sale any product with heat management material covered by the '119 Patent and its conduct is, in every instance, without Columbia Sportswear's consent.

59. Team Ortho will continue to manufacture, import, sell, use and induce others to use its infringing products unless enjoined by this Court.

60. Due to Team Ortho's infringement of the '119 Patent, Columbia Sportswear is entitled to recover from Team Ortho the damages it has sustained as a result of Team Ortho's wrongful acts in an amount subject to proof at trial, but in no event less than a reasonable royalty, together with interest and costs as fixed by this Court under 35 U.S.C. § 284.

61. Due to Team Ortho's infringement of the '119 Patent, Columbia Sportswear has suffered, is suffering, and will continue to suffer irreparable injury and damage for which Columbia Sportswear has no adequate remedy at law. Columbia Sportswear is therefore entitled

to a permanent injunction against Team Ortho's further infringing conduct.

COUNT IV –
INFRINGEMENT OF UNITED STATES
PATENT 8,453,270

62. Columbia Sportswear restates and realleges each of the allegations, photographs and figures of paragraphs 1-39 as if fully set forth herein.

63. Team Ortho has been, and presently is, infringing the '270 Patent, literally or under the doctrine of equivalents, within this judicial district by manufacturing, importing, using, inducing others to use, selling and/or offering for sale sportswear products, including but not limited to the pullover depicted herein, that includes heat management material that embodies the patented invention disclosed in the '270 Patent, in violation of 35 U.S.C. § 271.

64. Team Ortho is not licensed or otherwise authorized by Columbia Sportswear to manufacture, import, use, induce others to use, sell and/or offer for sale any product with heat management material covered by the '270 Patent and its conduct is, in every instance, without Columbia Sportswear's consent.

65. Team Ortho will continue to manufacture, import, sell, use and induce others to use its infringing products unless enjoined by this Court.

66. Due to Team Ortho's infringement of the '270 Patent, Columbia Sportswear is entitled to recover from Team Ortho the damages it has sustained as a result of Team Ortho's wrongful acts in an amount subject to proof at trial, but in no event less than a reasonable royalty, together with interest and costs as fixed by this Court under 35 U.S.C. § 284.

67. Due to Team Ortho's infringement of the '270 Patent, Columbia Sportswear has suffered, is suffering, and will continue to suffer irreparable injury and damage for which Columbia Sportswear has no adequate remedy at law. Columbia Sportswear is therefore entitled to a permanent injunction against Team Ortho's further infringing conduct.

COUNT V –
COPYRIGHT INFRINGEMENT,
PURSUANT TO 17 U.S.C. §§ 106 and 501

68. Columbia Sportswear restates and realleges each of the allegations, photographs and figures of paragraphs 1-39 as if fully set forth herein.

69. Team Ortho has infringed the Columbia Sportswear Copyrights within this judicial district by reproducing, distributing, and publicly displaying marketing and promotional material comprised of or incorporating works in which Columbia Sportswear owns certain copyright rights, without the permission of Columbia Sportswear, in violation of 17 U.S.C. §§ 106 and 501.

70. On information and belief, Team Ortho's acts of copyright infringement are willful, intentional and purposeful, in disregard of and with indifference to Columbia Sportswear's rights.

71. As a direct and proximate result of Team Ortho's infringement of the Columbia Sportswear Copyrights, Columbia Sportswear is entitled to damages in an amount to be proven at trial.

72. Columbia Sportswear is also entitled to Team Ortho's profits attributable to the infringement, pursuant to 17 U.S.C. § 504(b), including an accounting of and a constructive trust with respect to such profits.

73. Team Ortho will continue to reproduce, distribute, and publicly display marketing and promotional material comprised of or incorporating works in which Columbia Sportswear owns certain copyright rights unless enjoined by this Court.

74. Due to Team Ortho's infringement of the Columbia Sportswear Copyrights, Columbia Sportswear has suffered, is suffering, and will continue to suffer irreparable injury and damage for which Columbia Sportswear has no adequate remedy at law. Columbia Sportswear is therefore entitled to a permanent injunction against Team Ortho's further infringing conduct.

COUNT VI –
TRADE DRESS INFRINGEMENT, UNFAIR COMPETITION AND FALSE
DESIGNATION OF ORIGIN,
PURSUANT TO THE LANHAM ACT, 15 U.S.C. § 1125(a)

75. Columbia Sportswear restates and realleges each of the allegations, photographs and figures of paragraphs 1-39 as if fully set forth herein.

76. Team Ortho's use of a silver dot lining on and in connection with its products, including but not limited to the pullover depicted herein, is likely to cause confusion, or to cause mistake, or to deceive as to the affiliation, connection, or association of Team Ortho or its products with the Columbia Sportswear Group or products sold under the COLUMBIA® brand, or as to the origin, sponsorship, or approval of Team Ortho's products by the Columbia Sportswear Group, in violation of 15 U.S.C. § 1125(a).

77. To any ordinary observer, and to sportswear consumers and members of the industry, the "look" of the Team Ortho sportswear is confusingly similar to Columbia Sportswear's Silver Dot Trade Dress and, in particular, the ornamental, distinctive appearance of the Omni-Heat heat reflective material, including its evenly-distributed, small silver dot pattern, which is unique in appearance, eye-catching and readily recognized among customers and members of the industry.

78. Team Ortho's past, present and future use, distribution, sale and/or offer for sale of sportswear using material confusingly similar to the Silver Dot Trade Dress, including but not limited to the infringing pullover depicted herein, constitutes trade dress infringement, unfair competition and false designation of origin under 15 U.S.C. § 1125(a).

79. On information and belief, Team Ortho has been aware of Columbia Sportswear's Omni-Heat products and the Silver Dot Trade Dress based on its exact copying of the Columbia Sportswear Group's Omni-Heat promotional materials, including the exact copying of technical graphic and verbatim recital of language describing the features of Columbia Sportswear's

Omni-Heat products and the distinctive Omni-Heat “look,” *i.e.*, little silver dots. As such, Team Ortho’s infringing activities have been and continue to be willful and deliberate.

80. Due to Team Ortho’s willful trade dress infringement, unfair competition and false designation of origin, Columbia Sportswear is entitled to recover damages from Team Ortho in an amount to be determined at trial, including Team Ortho’s profits and three times the amount of actual damages sustained by Columbia Sportswear, together with costs and reasonable attorneys’ fees.

81. Furthermore, by these acts, Team Ortho has irreparably injured Columbia Sportswear and caused Columbia Sportswear to suffer a loss of goodwill and reputation, and such injury will continue unless Team Ortho’s activities are enjoined by this Court.

82. By reason of the above actions, Columbia Sportswear is entitled to a range of relief under the Lanham Act, 15 U.S.C. §§ 1116-1118.

COUNT VII –

**VIOLATION OF THE UNIFORM DECEPTIVE TRADE PRACTICES ACT,
PURSUANT TO 815 ILCS §§ 510/1 *et seq.***

83. Columbia Sportswear restates and realleges each of the allegations, photographs and figures of paragraphs 1-39 as if fully set forth herein.

84. Team Ortho has made, used, exported, imported, marketed, sold and/or offered for sale sportswear products, including but not limited to the pullover depicted herein, using the Silver Dot Trade Dress without permission, authority or license from Columbia Sportswear, in a manner that causes likelihood of confusion or of misunderstanding as to the source, sponsorship, approval, affiliation, connection, or association and/or certification of such products as set forth in 85 ILCS 510/2.

85. Such actions on the part of Team Ortho, particularly in conjunction with its infringement of the Columbia Sportswear Copyrights, are likely to cause confusion or mistake, or to deceive the sportswear-purchasing public as to the affiliation, connection, or association of Team Ortho or its products with Columbia Sportswear or its products, or as to the origin,

sponsorship, or approval of Team Ortho's products by Columbia Sportswear, as set forth in 815 ILCS 510/2

86. Team Ortho's deceptive trade practices as set forth above constitute violations of the Uniform Deceptive Trade Practices Act, 815 ILCS 510/1 *et seq.*, and have caused and, unless restrained by the Court, will continue to cause irreparable harm to Columbia Sportswear.

87. On information and belief, Team Ortho's deceptive trade practices as set forth above are willful, intentional and purposeful, in disregard of and with indifference to Columbia Sportswear's rights. Accordingly, Columbia Sportswear is entitled to recover damages from Team Ortho in an amount to be determined at trial, together with costs and reasonable attorneys' fees.

PRAYER FOR RELIEF

WHEREFORE, Plaintiff Columbia Sportswear respectfully requests that the Court enter judgment in its favor against Defendant Team Ortho, granting the following relief:

- A. A judgment and declaration that Team Ortho has infringed the Columbia Sportswear Patents literally and/or under the doctrine of equivalents;
- B. A judgment and declaration that Team Ortho has infringed the Columbia Sportswear Copyrights;
- C. A judgment and declaration that Team Ortho has infringed the Silver Dot Trade Dress and has engaged in unfair competition and false designations of origin;
- D. A judgment and declaration that Team Ortho has violated the Uniform Deceptive Trade Practices Act, 815 ILCS 510/1 *et seq.*
- E. A permanent injunction, pursuant to 35 U.S.C. § 283, enjoining Team Ortho and its agents, servants, officers, directors, employees, affiliated entities and all persons acting in concert or privity with them, from infringing each of the Columbia Sportswear Patents;
- F. A permanent injunction, pursuant to 17 U.S.C. § 502, enjoining Team Ortho and its agents, servants, officers, directors, employees, affiliated entities and all persons acting in concert or privity with them, from infringing each of the Columbia Sportswear Copyrights;

G. A permanent injunction, pursuant to 15 U.S.C. § 1116(a), enjoining Team Ortho and its agents, servants, officers, directors, employees, affiliated entities and all persons acting in concert or privity with them, from infringing the Silver Dot Trade Dress, and from engaging in unfair competition and false designations of origin;

H. A judgment and order requiring Team Ortho to pay Columbia Sportswear all damages caused by Team Ortho's infringement of each of the Columbia Sportswear Patents (but in no event less than a reasonable royalty) pursuant to 35 U.S.C. § 284; or, with respect to the '529 Patent and the '435 Patent, the total profits made by Team Ortho from its infringement of such patents pursuant to 35 U.S.C. § 289;

I. A judgment and order requiring Team Ortho to pay Columbia Sportswear all damages suffered by Columbia Sportswear and any additional profits of Team Ortho resulting from Team Ortho's infringement of each of the Columbia Sportswear Copyrights pursuant to 17 U.S.C. § 504(b), or statutory damages as provided in 17 U.S.C. § 504(c);

J. A judgment and order requiring Team Ortho to pay Columbia Sportswear all damages suffered by Columbia Sportswear as a result of Team Ortho's infringement of the Silver Dot Trade Dress, unfair competition and false designations of origin pursuant to 15 U.S.C. § 1117(a);

K. A judgment and order requiring Team Ortho to pay Columbia Sportswear any profits of Team Ortho attributable to its infringement of the Silver Dot Trade Dress, unfair competition and false designations of origin pursuant to 15 U.S.C. § 1117(a);

L. A judgment and order requiring Team Ortho to pay Columbia Sportswear supplemental damages or profits for any continuing post-verdict infringement up until the entry of a final judgment, with an accounting, if needed;

M. A judgment and order requiring Team Ortho to pay Columbia Sportswear increased damages up to three times the amount found or assessed pursuant to 35 U.S.C. § 284;

N. A judgment and order requiring Team Ortho to pay Columbia Sportswear pre-judgment and post-judgment interest on any damages or profits awarded;

- O. A determination that this action is an exceptional case pursuant to 35 U.S.C. § 285;
- P. A determination that this action is an exceptional case pursuant to 15 U.S.C. § 1117(a);
- Q. An award of Columbia Sportswear's attorneys' fees, costs and expenses incurred in bringing and prosecuting this action, pursuant to 35 U.S.C. § 285, 17 U.S.C. § 505, and 15 U.S.C. § 1117(a);
- R. An award of Columbia Sportswear's attorneys' fees, costs and expenses incurred in bringing and prosecuting this action, pursuant to 815 ILCS 510/3;
- S. A judgment and order impounding all infringing articles pursuant to 17 U.S.C. § 503;
- T. An order that Team Ortho deliver for destruction all articles infringing the Silver Dot Trade Dress and all means of making the same, pursuant to 15 U.S.C. § 1118; and
- U. Such other and additional relief as this Court deems just and proper.

DEMAND FOR JURY TRIAL

Pursuant to Fed. R. Civ. P. 38(b), Columbia Sportswear respectfully requests a trial by jury of all issues so triable.

Dated this 25th day of January, 2016.

Respectfully submitted,

SEYFARTH SHAW LLP

By: s/Matthew A. Werber

Matthew A. Werber (Bar No. IL 6287658)
131 South Dearborn Street, Suite 2400
Chicago, IL 60603-5577
Telephone: 312.460.5000
Facsimile: 312.460.7000
Email: mwerber@seyfarth.com

*Attorneys for Plaintiff, Columbia Sportswear
North America, Inc.*