

1 Robert A. Brooks (*admitted pro hac vice*)
 2 Kia L. Freeman (*admitted pro hac vice*)
 3 Keith E. Toms (*admitted pro hac vice*)
 4 Mead Mistic (*admitted pro hac vice*)
 Leah R. McCoy (*admitted pro hac vice*)
 Jason C. Williams (*admitted pro hac vice*)
McCARTER & ENGLISH, LLP
 265 Franklin St.
 Boston, MA 02110
 Telephone: 617-449-6500
 Facsimile: 617-607-9200
rbrooks@mccarter.com
kfreeman@mccarter.com
 ktoms@mccarter.com
 mmistic@mccarter.com
 lmccoy@mccarter.com
 jwilliams@mccarter.com

**ATTORNEYS FOR PLAINTIFF
 OPTOLUM, INC.**

**IN THE UNITED STATES DISTRICT COURT
 FOR THE DISTRICT OF ARIZONA
 PHOENIX DIVISION**

	§	
OPTOLUM, INC.,	§	
Plaintiff,	§	Civil Action No.
v.	§	COMPLAINT
CREE, INC.	§	
Defendant.	§	JURY TRIAL DEMANDED

**FIRST AMENDED COMPLAINT FOR VIOLATIONS OF THE LANHAM ACT,
UNJUST ENRICHMENT, AND PATENT INFRINGEMENT**

1
2
3 Plaintiff OptoLum, Inc. (“OptoLum”), by and through its attorneys McCarter & English,
4 LLP, by way of Complaint against the above-named Defendant, Cree, Inc. (“Cree”), hereby
5 states as follows:
6

7
8 **INTRODUCTION**

9 1. As of March 2013, America had a serious lighting problem.

10 2. To reduce dependence upon foreign oil, encourage the production of clean
11 renewable fuels and promote energy efficiency, Congress passed the Energy Independence Act
12 in 2007 that, among other things, mandated the phase out of traditional incandescent bulbs by
13 the end of 2014.

14 3. In 2008, the Department of Energy (“DOE”) announced the L Prize or Bright
15 Tomorrow Lighting Prize with the intent to “spur lighting manufacturers to develop high-
16 quality, high-efficiency solid-state lighting products to replace the common incandescent
17 bulb.”

18 4. More specifically, the competition was focused on the design and development of
19 a replacement for the 60-watt incandescent light bulb and specified that the winner would have
20 to design and build a bulb capable of producing more than 90 lumens per watt while operating
21 at less than 10 watts and achieving a total light output of over 900 lumens.
22

23 5. The competition further required that the bulb have a useful life of more than
24 25,000 hours and produce a warm light similar to the 60-watt incandescent bulb.

25 6. On August 3, 2011, after two years of testing, DOE announced that Philips
26 Lighting, a division of the Dutch Company Koninklijke Philips N.V. and the only company to
27
28

1 have entered the competition, had won the L Prize with a bulb that utilized light-emitting
2 diodes (“LEDs”) as its source of illumination.

3 7. Philips began selling its bulb, branded as the EnduraLED,TM on the internet in
4 February of 2012 and in retail stores on Earth Day, April 22, 2012.

5 8. Americans loved incandescent bulbs, however, and for good reason: they were
6 familiar, having been in use since being introduced by Thomas Edison in the late 19th century,
7 inexpensive to purchase and they produced a warm, omnidirectional light.
8

9 9. With the imminent ban of incandescent bulbs looming large, the only alternatives
10 for the American consumer were compact florescent or CFL bulbs and a smattering of LED
11 bulbs, with the Philips EnduraLEDTM as the leading option.

12 10. Compared to incandescent bulbs, CFLs had a number of drawbacks, including the
13 fact that they were slow to reach full power and were made using mercury. They were also
14 somewhat strange in appearance and looked nothing like traditional incandescent bulbs. And
15 the biggest problem with CFLs was that the light they produced was just plain unappealing to
16 consumers.
17

18 11. Although it was more energy efficient and had a much longer useful life than
19 either incandescent or CFL bulbs, the Philips EnduraLEDTM also had a number of
20 shortcomings. Like the CFLs, it was odd looking. It was also very expensive, retailing for
21 about \$50 a bulb. Lastly, while the light it produced was warmer than that of CFLs, it still
22 wasn’t the centralized, omnidirectional light that Americans had grown accustomed to with
23 incandescent bulbs.
24

25 12. Enter Cree, a company that specialized in compound semiconductor technology
26 and the manufacture of LED components that was, in the words of its CEO, Chuck Swoboda,
27
28

1 “a company nobody ever heard of.” More specifically, on March 5, 2013, Cree announced the
2 release of two LED bulbs—one a replacement for a 40-watt incandescent bulb and the other
3 for the 60-watt bulb—as well as the fact that the bulbs were sitting on the shelves and available
4 for sale at 2,000 Home Depots across the country.

5 13. The Cree bulbs were relatively cheap, selling for \$9.99 and \$12.97 respectively,
6 looked like traditional incandescent bulbs, had a much longer useful life and produced the
7 same warm, centralized, omnidirectional light as incandescents.
8

9 14. Although not announced at the time it made this bold and completely
10 unanticipated move into the LED lightbulb market, Cree, on information and belief, had its
11 eyes on a bigger prize: to leverage the sale of LED bulbs to residential customers to increase
12 awareness and acceptance of LED lighting and thereby pave the way for Cree to compete in
13 the far bigger and more lucrative LED commercial lighting market.
14

15 15. On information and belief, to succeed with this two-pronged strategy, Cree
16 believed that it was imperative that consumers believe that the technology in Cree’s bulbs was
17 truly innovative.

18 16. Accordingly, and simultaneously with the release of its bulbs and continuing to
19 the present day, Cree unleashed an extensive marketing and public relations campaign
20 heralding the novelty of the design of its bulbs.
21

22 17. Thus in television ads, interviews on television, public speeches and on its
23 company YouTube channel, Cree touts not only the energy efficiency and low cost of the Cree
24 LED bulb, but also the fact that it produced the same omnidirectional light as an incandescent
25 bulb while also having a long useful life while crediting these features to what Cree called the
26
27
28

1 “Cree Filament TowerTM Technology” which Cree hails as “the genius idea inside” the Cree
2 LED bulb.

3 18. Cree also attacked and continues to attack its competitors.

4 19. In an ad that is currently being aired on ESPN, a famous actor appears with a
5 number of other individuals meant to represent Cree’s LED bulb competitors and accuses them
6 of being “copycats.” The ad ends with the actor invoking the familiar saying that “[i]mitation is
7 the sincerest form of flattery” as his words are echoed by the supposed competitors ending
8 with the repetition of the word “flattery.”

9
10 20. By this reasoning, it is OptoLum and, more particularly, its founder and CEO,
11 Joel Dry, who should be flattered as it was Mr. Dry who, many years before Cree, created an
12 energy-efficient LED bulb with the structure that Cree calls the Cree Filament TowerTM or the
13 “genius” of its LED bulb that had a longer useful life than an incandescent bulb, produced the
14 same warm, centralized, omnidirectional light and whose patented design for his invention the
15 Cree Filament TowerTM infringes.

16
17 21. Neither OptoLum nor Mr. Dry is flattered by Cree’s conduct, however, which
18 constitutes not only infringement of OptoLum’s patented technology but also misappropriation
19 of the reputation and good will to which it was entitled as a consequence of its remarkable
20 achievement.

21
22 22. OptoLum is both a customer of Cree for LED chips as well as a competitor in
23 LED commercial lighting.

24 23. Cree’s strategy has been extremely effective with the sale of LED lighting
25 products accounting for approximately \$900 million of Cree’s \$1.6 billion in annual revenues
26 as of June 26, 2016.

1
2
3
4
5
6
7
8
9
10
11
12
13
14
15
16
17
18
19
20
21
22
23
24
25
26
27
28

24. Cree’s conduct is even more egregious in light of the fact that at least Mr. Swoboda and one of Cree’s founders, John Edmond, had attended LED lighting shows and conferences during the period 2003 – 2004 at which Mr. Dry exhibited his bulb and explained that it was patented. Mr. Dry also met with at least Dr. Edmond individually and explained in detail how his bulb worked.

25. Accordingly, OptoLum brings this action to recover damages and injunctive relief for false advertising under the Lanham Act, 15 §§ U.S.C. 1051, *et seq.*; for unjust enrichment; and for infringement of U.S. Patent Nos. 6,831,303 and 7,242,028 (collectively the “Asserted Patents”), pursuant to 35 U.S.C. §§ 271, *et seq.*

26. A true and correct copy of U.S. Patent No. 6,831,303, (the “303 Patent”) is attached as Exhibit A.

27. A true and correct copy of U.S. Patent No. 7,242,028 (the “028 Patent”) is attached as Exhibit B.

PARTIES

28. OptoLum is a corporation organized under the laws of the state of Arizona with a principal place of business at 1407 West 10th Place, Suite 107, Tempe, AZ 85281.

29. OptoLum is both a customer and competitor of Cree in the sale of LED commercial lighting products.

30. Upon information and belief, Cree is a corporation organized under the laws of the state of North Carolina, with a principal place of business at 4600 Silicon Drive, Durham, NC, 27703.

JURISDICTION AND VENUE

31. The amount in controversy exceeds \$75,000 exclusive of interest and costs.

32. This Court has subject matter jurisdiction over this action under 15 U.S.C. § 1121 and 28 U.S.C. §§ 1331, 1332, 1367 and 1338(a).

33. This Court has general and/or specific personal jurisdiction over Cree, and venue in this district is proper, in part because Cree, directly and/or in combination with its subsidiaries and/or through agents, does continuous and systematic business in the State of Arizona, including by distributing false advertising, offering its products and/or services for sale, including those accused herein of infringement, to customers and/or potential customers located in this state and by providing infringing products that it knew would be used within the state. In addition, upon information and belief, Cree, directly or through its subsidiaries, places false advertising and infringing products within the stream of commerce, which is directed at the State of Arizona, with the knowledge and/or understanding that such products will be sold, leased, or otherwise provided to customers within this state and obtains unjust enrichment within this state as a result. In addition, upon information and belief, Cree, directly or through its subsidiaries, employs individuals within this state, including employees who provide infringing products and services to customers here and maintain offices and facilities here. Cree, directly or through its subsidiaries and/or agents, operates highly commercial websites through which false advertising and regular sales and/or leases of products and/or services are made to customers in the State of Arizona, including products that, on information and belief, infringe the Asserted Patents. Moreover, the asserted causes of action arise out of actions by Cree within the State of Arizona.

34. Accordingly, this Court has personal jurisdiction over Cree and venue in this district is proper under 28 U.S.C. §§ 1391(b), 1391(c) and/or 1400(b).

FACTUAL BACKGROUND

THE HISTORY OF SOLID-STATE LIGHTING

35. This case involves what is known as solid-state lighting (“SSL”) and, more particularly, a form of solid-state lighting that uses light-emitting diodes (“LEDs”) as a source of illumination.

36. LEDs are made using semiconductor materials, which are solid materials with distinct electrical characteristics, as reflected in the very name “semiconductor.”

37. More specifically, the name semiconductor is derived from the fact that the material has conductivity but lower than that of typical conductors and is also insulating but not to the same degree as typical insulators.

38. Significantly, the conducting and insulating properties of semiconductor materials may be altered in a useful way by a controlled introduction of impurities through a process known as doping.

39. Doping involves the introduction of electron-rich or electron-deficient atoms into the semiconductor host material, changing the properties of the material in which they are embedded by providing a surplus or deficit of free electrons. The concentration of freely roaming electrons is proportional to the conductivity of the material.

40. During doping, both electron-rich and electron-deficient atoms known as “p-type” and “n-type” dopants may be embedded into the crystalline structure of the semiconductor. In such instances, the “p” (positive) side of the semiconductor host material contains an excess of electron holes, while the “n” (negative) side contains an excess of electrons.

41. The boundary between the n-type and p-type implanted regions is known as “the p-n junction.”

1 42. The p-n junction is the building block for most semiconductor electronic
2 components, such as diodes and transistors, that are used to create the integrated circuits found
3 in all laptops and mobile phones as well as LEDs.

4 43. When suitable current is applied to the leads of an LED, the surplus electrons
5 combine with holes within the p-n junction and release energy in the form of photons of light,
6 lighting up the LED.

7 44. This effect is known as electroluminescence.

8 45. The development of semiconductor diodes and transistors, as well as the
9 surrounding technologies, like all complicated technology fields, has been many years in the
10 making and is the product of the creative efforts of countless engineers and scientists from
11 around the world.
12

13 46. One of the first practical applications of semiconductors was the development of
14 an early semiconductor diode, known as a cat's-whisker detector, in 1904 that was used in
15 early crystal receivers.
16

17 47. An American physicist, Russell Ohl of Bell Laboratories, is credited with
18 inventing the p-n junction in 1939.

19 48. The p-n junction was first reported by a Russian scientist, Vadim Lashkaryov, in
20 1941.
21

22 49. The transistor was developed in 1947 followed by the integrated circuit in 1958.

23 50. As with semiconductors, the history of LEDs began a long time ago and is also
24 the product of numerous discoveries by a myriad of talented individuals.

25 51. These discoveries traversed numerous disciplines, including physics, material
26 science, electrical engineering, mechanical engineering and optics.
27
28

1 52. Silicon is not suitable for making LEDs. Accordingly, an added complication to
2 the creation of the LED was the need to find combinations of different materials with the right
3 optoelectronic properties for producing light of desired wavelengths. The selected materials are
4 then manufactured or “grown” in gas-filled chambers on a base material known as a substrate
5 into very thin layers by a process known as epitaxy. The resulting LED consists of a stack of
6 these layers which may include differing compositions and doping concentrations, depending
7 on a particular design. As such, LEDs are said to be made from compound semiconductors.
8

9 53. Electroluminescence was discovered in 1907 by the British scientist Henry J.
10 Round using a crystal of silicon carbide and a cat’s-whisker detector.

11 54. Soviet inventor Oleg Losev reported creation of the first LED in 1927, using a
12 point-contact diode, a precursor to the p-n junction diodes used in modern LEDs.
13

14 55. In 1955, Rubin Braunstein, who worked at Radio Corporation of America,
15 reported the first infra-red emitting diodes, made from gallium arsenide (“GaAs”) and other
16 semiconductor alloys.

17 56. In 1961, Gary Pittman and Bob Baird from Texas Instruments found that the
18 GaAs diode emits near-infrared light.

19 57. The first visible-spectrum (red) LED was developed in 1962 by Nick Holonyak,
20 Jr. and the shorter wavelength green LED appeared shortly thereafter.
21

22 58. In 1972, M. George Craford, who was a graduate student of Holonyak, invented
23 the first yellow LED and a brighter red LED.

24 59. These LEDs began appearing in electronic devices such as indicator lamps and
25 numeric readouts in digital clocks.
26
27
28

1 60. On information and belief, in 1989, Cree, which had been formed two years
2 earlier to develop LED chips, commercialized the first low power blue LED.

3 61. The development of a higher-power and higher-brightness blue LED proved more
4 challenging, and it was not until the mid-1990s that a Japanese engineer, Shuji Nakamura,
5 building upon gallium nitride (“GaN”) discoveries by fellow countrymen Isao Akasaki and
6 Hiroshi Amano, demonstrated the first higher-brightness blue LED while working at Nichia
7 Corporation in Japan.
8

9 62. The higher-brightness blue LED development was quickly followed by the
10 development of the first white LED created by combining the blue LED with a phosphor
11 coating that absorbed some of the high energy wavelengths of light, such as the blue light, and
12 in turn, emitted lower-energy wavelength light such as green, yellow and red through a process
13 known as fluorescence. The combination of the blue light that is not absorbed by the phosphor
14 with the green, yellow, red and other color light that is emitted by phosphor appears white to
15 the human eye resulting in the white LED.
16

17 63. As impressive as these accomplishments were, LEDs still lacked the ability to
18 produce a sufficient quantity of light for general lighting purposes.

19 64. In order to bridge this gap, it was necessary to create a new and larger LED chip
20 that could be operated at even higher power levels.
21

22 65. This challenge was made more difficult by the fact that higher-power LEDs
23 generate a significant quantity of heat which, in turn, has adverse effects on the semiconductor
24 and thus the useful life of the LED, as well as the quality and consistency of the light it
25 produces.
26
27
28

1 66. In 1998, engineers at Hewlett-Packard Company (“HP”) designed what were
2 known as power LEDs consisting of a larger LED chip to be used in applications such as
3 traffic signal lights and signs in lieu of multiple small indicator type LEDs populated with tiny
4 light-emitting chips. These LEDs were made using aluminum indium gallium phosphide
5 (“AlInGaP”) on a sapphire substrate and produced red light.
6

7 67. In order to manage the increased heat loads caused by the higher power levels, HP
8 introduced a “slug” also known as the “thermal pad” which was a piece of thermally-
9 conductive material in thermal contact with the p-n junction of the LED that acted as a thermal
10 path for direct dissipation of heat from the p-n junction to an external heat sink.

11 68. HP applied for a patent on this technology in 1998, which issued as U.S. Patent
12 No. 6,274,924 in 2001 and was assigned to Lumileds Lighting (“Lumileds”), a company that
13 had been formed in November of 1999 in connection with the spin-off of HP’s Optoelectronic
14 Division to a joint venture formed by Philips Lighting (“Philips”) and Agilent Technologies.
15

16 69. Building upon their patented heat management system, and with an eye on
17 producing an LED suitable for general lighting purposes, the engineers at Lumileds then turned
18 their attention to blue LEDs made from indium gallium nitride (“InGaN”), also on a sapphire
19 substrate, that operated at power levels that were higher by an order of magnitude than the
20 power levels of their predecessors. These devices, which were referred to as “high-power
21 LEDs” or “one-watt class LEDs” and sold under the brand Luxeon®, became the *de facto*
22 standard in the industry, launched a number of LED lighting applications and inspired many
23 other manufacturers, including Cree, to begin designing comparable power packages suitable
24 for general lighting with some form of dedicated thermal path.
25
26
27
28

CREE'S DEVELOPMENT OF HIGH-POWER WHITE LEDS

1
2 70. As alleged in paragraph 30, *supra*, Cree was established in 1987 and is
3 headquartered in Durham, North Carolina.

4 71. On information and belief, five of Cree's six founders are graduates of North
5 Carolina State University where they studied the use of silicon carbide ("SiC"), a rare,
6 naturally-occurring mineral compound, as a semiconductor material.
7

8 72. Based in part upon the experiments of scientists from all over the world including
9 what was then the Soviet Union, on information and belief, Cree's founders knew that SiC
10 could be used as an LED light source.

11 73. On information and belief, while at North Carolina State University, the founders
12 also devised a way to grow SiC in a laboratory.
13

14 74. On information and belief, Cree was formed to exploit this technology and
15 succeeded in growing large quantities of SiC despite having to overcome many technological
16 challenges along the way.

17 75. These accomplishments made Cree the leading SiC wafer supplier for many
18 technology companies that, on information and belief, relied on it for various optical,
19 electronic or radio-frequency applications for years to come.
20

21 76. On information and belief, Cree also recognized the potential of SiC as a material
22 for building SSL devices, including laser diodes and LEDs, in view of the fact that SiC is
23 capable of withstanding high voltages and high temperatures, while also having high thermal
24 conductivity.

25 77. Moreover, on information and belief, Cree's engineers understood that SiC, as a
26 large band gap material, was capable of emitting "cooler colors," such as ultraviolet, blue and
27
28

1 green, and thus, like the InGaN used by Lumileds, was suitable for building white LEDs and
2 laser diodes.

3 78. In 1989, on information and belief, Cree introduced the first commercial blue
4 LED and was the first company to bring it to market in 1991.

5 79. On information and belief, Cree introduced its first blue lasers around 1997.

6 80. By comparison to the Luxeon® chip created by Lumileds years earlier, however,
7 on information and belief, the light intensity of Cree's SiC-based SSL devices remained low
8 due at least in part to the tendency of SiC material to absorb a substantial amount of the light it
9 was emitting.
10

11 81. On information and belief, Cree spent a number of years trying to improve the
12 brightness of its SiC-based LEDs before coming to the realization that SiC material simply
13 could not provide the same level of performance that InGaN already provided to Lumileds and
14 others.
15

16 82. Accordingly, on information and belief, Cree switched its design and, as Lumileds
17 had done previously, began building its LEDs based on GaN or InGaN design, but did so on
18 SiC substrates as opposed to the sapphire substrates used by Lumileds.

19 83. Because SiC is also a highly thermally conductive material, on information and
20 belief, Cree's SiC substrate was initially able to perform the same heat dissipation function for
21 Cree's high-power LEDs as the patented thermal pad or heat slug had done on the Lumileds
22 LEDs.
23

24 84. In terms of light output performance however, on information and belief, Cree's
25 LEDs continued to lag behind those of Lumileds's Luxeon® chips for at least a number of
26 years.
27
28

1 85. On information and belief, it was therefore necessary, in the end, for Cree to
2 incorporate a version of a heat slug, made from the SiC substrate, into its high-power white
3 LED chip design.
4

5 OPTOLUM’S CONTRIBUTIONS TO SOLID-STATE LIGHTING

6 86. Despite its small size and limited funds, OptoLum was also a leading pioneer in
7 the field of the effective heat management of high-power LEDs as well as the design of LED
8 bulbs as replacements for traditional lighting.

9 87. Mr. Dry understood the variety of constraints within which small form factor
10 bulbs had to work in order to accomplish the goal of delivering LED light that was equivalent
11 to that of traditional incandescent bulbs. He also recognized the paramount importance of
12 effective heat management as well as the challenge of managing heat with a small form factor
13 heat sink that had to operate within the confines of a traditional bulb and appreciated the fact
14 that effective heat management would extend the useful life of the bulb, improve its energy
15 efficiency and require less material than a conventional heat sink and thereby lower the cost of
16 the bulb. Lastly, Mr. Dry was aware of the need to replicate the illumination characteristics of
17 conventional incandescent and CFL bulbs in lighting applications including an omnidirectional
18 light that emanated from the center of the bulb.
19
20

21 88. More particularly, Mr. Dry conceived of and reduced to practice the design of an
22 LED bulb that could replace either traditional incandescent or CFL bulbs.

23 89. Mr. Dry first applied for a patent on this technology on May 29, 2002 and has
24 obtained a number of patents since that time.

25 90. Mr. Dry’s first patent, U.S. Patent No. 6,573,536 (the “’536 Patent”), issued on
26 June 3, 2003.
27
28

1 91. In one embodiment of Mr. Dry's invention, the lamp comprises a hollow,
2 elongated tubular heat sink configured to have LEDs dispersed around the outer surface and in
3 direct thermal contact with the heat sink to conduct heat away from the LEDs to air contained
4 therein. In another embodiment, external fins or protrusions are added to the elongated tubular
5 heat sink.

6 92. In 2003, OptoLum built the first of the BrightLife™ series of LED bulbs, that fit
7 within the desired form factor and produced light comparable to the CFLs used in wall
8 sconces. Mr. Dry also conducted testing to demonstrate the energy efficiency and longevity of
9 his bulb.

10 93. Mr. Dry modeled his prototype on the CFL bulb for two reasons. First, he
11 recognized that the high cost of LEDs at the time made it unlikely that consumers would
12 purchase them as replacements for the incandescent bulbs in their homes. Second, the U.S.
13 Government was actively promoting CFLs at the time.

14 94. Had there been consumers interested in purchasing LED bulbs as replacements
15 for incandescents, Mr. Dry could have easily adapted the design of his prototype for this
16 purpose.

17 95. OptoLum's bulb used the Lumileds industry-leading high-power LEDs as a light
18 source.

19 96. More specifically, Lumileds supplied OptoLum with the warmest and brightest
20 LEDs it had at the time.

21 97. OptoLum's bulb was widely admired in LED lighting circles at the time.

22 98. During the period 2003–2005, OptoLum demonstrated its bulb at LED lighting
23 conferences throughout the world.

1 99. The LED lighting community was very small at that time, and the number of
2 people attending the conferences was nowhere near as high as it is at present. As such, the
3 participants were very much aware of what others in this community – including Mr. Dry and
4 OptoLum – were doing.

5 100. OptoLum distributed various written materials at these conferences that explained
6 in detail how Mr. Dry’s innovative bulb and heat management system worked together with
7 test data that substantiated OptoLum’s estimates of the useful life of its bulb.

8 101. At each of these conferences, Mr. Dry also made it clear that his bulb was
9 patented.

10 102. Indeed, the press releases OptoLum issued each time it had applied for or was
11 awarded a patent provided further notice that OptoLum was in the process of patenting this
12 technology.
13

14 103. The OptoLum bulb was so well received that Lumileds elected to use it to
15 showcase its highest-performing LEDs at various LED lighting conferences and shows.
16

17 104. On occasion, Lumileds even invited OptoLum to share the same booth.
18

19 CREE’S AWARENESS OF OPTOLUM’S LED BULB

20 105. Various Cree employees were present at these conferences and shows.

21 106. At the Blue Conference held in Dallas, Texas from June 11 to 13, 2003, Mr. Dry
22 participated in a round table discussion regarding new developments in LED technology during
23 which he showed his BrightLife™ bulb in operation. After the presentation, Mr. Dry met John
24 Edmond, one of the co-founders of Cree and explained the design of his bulb in detail. Dr.
25 Edmond expressed admiration for Mr. Dry’s bulb as did others at this and various other
26 conferences.
27
28

1 107. In addition, during the same conference, Mr. Dry met Dr. Edmond in a hotel,
2 where the two continued to discuss the OptoLum BrightLife™ bulb.

3 108. Mr. Dry met Chuck Swoboda, who was then and remains Cree's CEO, at the
4 Strategies in Light Conference held from February 2 to 4, 2004 in San Mateo, CA where Mr.
5 Dry again exhibited his BrightLife™ bulb.
6

7 109. At the May 11 – 12, 2004 Blue Conference in Hsinchu, Taiwan, at which Mr.
8 Swoboda was also present, Mr. Dry gave another presentation regarding the state of LED
9 lighting.
10

11 CREE'S ATTEMPT TO DESIGN A PROTOTYPE OF AN LED BULB

12 110. Upon information and belief, Cree has been the beneficiary of millions of dollars
13 in funding and tax credits from the United States Government to help it develop LED
14 technology, including a \$20 million grant from the DOE for the period from 2001 through
15 2004 to design, among other things, a prototype of a heat sink for a white LED bulb.
16

17 111. Cree designed a number of prototypes during this period.

18 112. The design of each of Cree's prototypes was substantially different from that
19 designed by OptoLum.

20 113. The LEDs used by Cree were mounted on a single plane and, as such, Cree's
21 prototype was incapable of producing omnidirectional light comparable to traditional
22 incandescent or CFL bulbs.

23 114. Cree's prototypes also failed to address the small form factor issues that are
24 critical to designing replacements for traditional incandescent and CFL bulbs and would have
25 been impractical and inefficient to use in such applications.
26
27
28

1 115. Like OptoLum, Cree tested its prototypes and presented a summary of the test
2 results in a report published in May of 2005.

3 116. The 28-page summary report fails, however, to disclose many details relevant to
4 fully appreciating Cree's conclusions with respect to the benchmarks that it claimed it
5 achieved. In fact, the report does not provide the level of detail sufficient to confirm any major
6 aspect of Cree's research or conclusions.

7 117. Based upon the respective tests, it appears likely that OptoLum's bulb
8 substantially outperformed Cree's prototype, especially for the purposes of small form factor
9 LED bulb applications.

10 118. For a variety of reasons, including the high costs of LEDs at the time, consumers
11 of fixtures and lighting products were not ready to embrace LED bulbs as replacements for
12 incandescent bulbs or CFLs.

13 119. Accordingly, OptoLum shifted its focus to designing and manufacturing LED
14 lighting fixtures for use in commercial lighting.

15 120. Publicly, Cree continued to focus on its core LED business of designing and
16 manufacturing LED chips and packages to be used in LED lighting fixtures and products.

17 **CREE'S CLANDESTINE SCHEME TO COMPETE WITH ITS LED FIXTURE AND**
18 **LIGHTING PRODUCTS CUSTOMERS**

19 21. Meanwhile, as alleged in paragraphs 12–19 *supra*, on information and belief, Cree
20 decided that the greatest and most lucrative opportunities for LED lighting were in LED
21 commercial lighting and, more specifically, from sales to the same customer base targeted by
22 Cree's own LED fixture and lighting product customers and conceived of and began to
23 implement a long-term and covert strategy of competing with its own customers directly.
24
25
26
27
28

1 122. On information and belief, Cree also came to the realization that the best way to
2 succeed with its plan was to sell LED bulbs to consumers for residential purposes as a
3 replacement for the traditional incandescent bulbs and thereby increase awareness and
4 acceptance of LEDs for commercial lighting purposes.
5

6 123. Finally, on information and belief, Cree understood that the linchpin of this effort
7 was to leverage the sale of LED bulbs to create a brand that would position Cree as a leading
8 innovator and the most talked about company in LED lighting and launched a massive
9 marketing and public relations effort to achieve this end.

10 124. In the execution of this strategy, Cree copied the design of Mr. Dry's LED bulb
11 which it had known about since 2003. Whether this was done because Cree was unable to
12 come up with an alternative design or in a rush to get the Cree bulb to the market before other
13 LED bulb manufacturers were able to do so is unknown at the present time. And, to make
14 matters worse, Cree claimed that it had created the Cree Filament Tower™, calling it "the
15 genius inside" the Cree LED bulb, despite knowing that it had, in fact, been created by Mr. Dry
16 a decade earlier, thereby appropriating to itself a reputation that properly belonged to Mr. Dry
17 and OptoLum.
18

19 125. In August of 2005, just a few months after Cree submitted its 28-page report to
20 the DOE, Cree announced that a group of Cree employees, including Neal Hunter, a co-
21 founder of Cree, and Gerald Negley, Cree's Chief Innovation Officer, had left the company to
22 form a new company called LED Lighting Fixtures, Inc. ("LLF").
23

24 126. Upon information and belief, LLF was formed for the express purpose of
25 designing and manufacturing LED fixtures and lighting products.
26
27
28

1 127. Cree denied reports that the spin-off of LLF was orchestrated by Cree to deflect
2 rumors that it was intending to compete with its LED fixture and lighting product customers.

3 128. On March 4, 2008, less than three years after the creation of LLF, Cree
4 announced that it had acquired the company for \$103 million.

5 129. LLF was renamed Cree LED Lighting Solutions and Mr. Hunter, then the
6 Chairman and CEO of LLF, rejoined Cree as President of that business unit, while Mr. Negley
7 assumed the position of Chief Scientist at Cree.
8

9 130. In response to a second wave of rumors that the acquisition of LLF meant that
10 Cree intended to compete with its LED fixture and lighting product customers, Mr. Swoboda
11 stated:

12 In fact it doesn't and the reason is that our fixture customers are
13 focused on building completely new fixtures, for new construction
14 applications. LLF fills an unserved need in the marketplace today,
15 allowing us to address this retrofit market for existing lighting
16 sockets. In parallel with our XLamp customers, we can lead the
adoption of LED lighting and drive demand – this helps us but also
really helps our XLamp customers.

17 131. Because of this, Mr. Swoboda maintained, Cree's acquisition of LLF in fact
18 "complement[ed] the strategy of our LED customers, [since] they are focused on applications
19 that require complete new fixtures."

20 132. Mr. Swoboda further explained that Cree had bought LLF both to assist Cree
21 engineers in designing LED chips and packages that met market needs and to help chart a
22 course for its LED fixture and lighting product customers to follow.
23

24 133. Lastly, he referred to the newly-created Cree LED Lighting Solutions business
25 unit as a demonstration vehicle to help move the market to more widespread acceptance of
26 LED lighting.
27
28

1 134. A couple of months later, at the Lightfair International Conference held from May
2 26 to 28, 2008 in Las Vegas, Nevada, and as alleged *supra* in paragraphs 3–6, the DOE
3 launched the L Prize competition.

4 135. Cree did not enter the competition.

5 136. In May of 2010, Cree announced that its Cree LED Lighting Solutions unit had
6 designed and was selling an LED retrofit replacement for 6-inch diameter LR6 downlights
7 used in recessed lighting under the EcoSmart brand and that it had formed a partnership with
8 Home Depot to sell the product in Home Depot stores.

9 137. In December of 2010, delivering the keynote address at the LED Lighting
10 Designer Seminar held in Newport Beach, California, Mr. Swoboda reiterated Cree’s earlier
11 statements that it had no intention of competing with its customers.
12

13 138. Mr. Swoboda stated that Cree’s “only objective was to get [Home Depot] to put
14 the demo into the store” as part of an awareness campaign so that Cree could test what would
15 move the SSL market and better serve its customers. He emphasized that Cree’s larger focus
16 remained on accelerating its LED package marketed as the XLamp®.
17

18 139. Despite not having entered the competition for the L Prize, Cree announced the
19 development of two engineering prototype LED bulbs in 2011, one in January of 2011 for what
20 Cree described as a prototype for a 60-watt incandescent replacement and the other, in a
21 remarkable coincidence, just two days before the DOE’s announcement of the winner of the L
22 Prize, for a prototype that Cree claimed exceeded the L Prize requirements for the 21st Century
23 Lamp—despite the fact that those requirements had not then and still have not been fully
24 articulated.
25
26
27
28

1 140. Again, Cree assured its LED fixture and lighting product customers that it had no
2 intention of competing with them and had developed the prototypes consistent with its strategy
3 of helping them develop LED lighting products.

4 141. On August 3, 2011, after two years of testing and just two days after Cree had
5 trumpeted the release of its latest prototype, it was announced that Philips had won the L Prize
6 and would receive a \$10 million cash prize.

7 142. Only two weeks later, on August 17, 2011, Cree announced the acquisition of
8 Ruud Lighting of Racine, Wisconsin, a longtime LED fixture customer of Cree that
9 manufactured LED outdoor lighting for street lights and parking garages sold under the brand
10 BetaLED®, for \$525 million.

11 143. Once again, Mr. Swoboda insisted that the move was intended to help its
12 customers remove roadblocks to widespread adoption of SSL, stating: "Cree is taking another
13 bold step in leading the LED lighting revolution, creating a company that has an unrivaled
14 focus and commitment to driving LED lighting adoption."
15

16 144. Mr. Swoboda also echoed the statements he had made in 2008 and 2010 that the
17 acquisition would enable Cree to gain even more knowledge and expertise regarding what
18 Cree's LED fixture and lighting product customers would need in next-generation LEDs.
19

20 145. The Philips bulb, known as the EnduraLED™, was released commercially in
21 February 2012 and sold online. It was made available for sale in retail stores on Earth Day,
22 April 22, 2012.

23 146. On information and belief, to maintain the secrecy of this project, Cree leased an
24 unmarked off-site facility in Durham, North Carolina.
25
26
27
28

1 147. On information and belief, Mr. Hunter was put in charge of this clandestine
2 project and was assisted by Mr. Swoboda, Mr. Edmond, Mr. Negley and others.

3 148. By March of 2013, Cree had completed its work on two LED bulbs—one a
4 replacement for the 40-watt incandescent and the other a 60-watt incandescent replacement.
5 Cree had also begun manufacturing the bulbs, negotiated a distribution agreement with Home
6 Depot and delivered the first shipments of bulbs to Home Depot for sale.

7 149. The project remained shrouded in secrecy, however, until the morning of March
8 5, 2013 when Cree announced publicly that the bulbs were already on the shelves of over 2,000
9 Home Depot stores around the country and available for sale. Indeed, on information and
10 belief, on the date of this announcement, less than 200 Cree employees knew anything about
11 the project.
12

13
14 CREE’S EFFORTS TO PATENT ITS BULB AND FAILURE TO CITE OPTOLUM’S
15 PATENTS AS MATERIAL PRIOR ART

16 150. Before the release, Cree began the process of filing a number of applications to
17 patent the LED bulbs.

18 151. In fact, as early as July, October and December of 2012, Cree had filed several
19 provisional patent applications, which formed the basis of a majority of subsequently
20 prosecuted and now issued, U.S. Patents on Cree’s LED bulbs including at least: U.S. Patent
21 Nos. 8,591,062; 8,752,983; 8,757,839; 9,052,093; 9,234,638; 9,234,655; 9,310,028; 9,310,065;
22 9,322,543; 9,353,937; 9,395,074 and 9,410,687 (“the Cree LED Bulb Patents”).
23

24 152. In one example, filed on March 1, 2013, Cree requested a prioritized examination
25 by the United States Patent Office (“USPTO”) known as a “Track One Request,” which fast-
26 tracks a patent prosecution. This request was granted and resulted in U.S. Patent No. 8,752,983
27 (the “’983 Patent”) being issued on June 17, 2014, a mere 15 months after the filing date.
28

1 153. As demonstrated below, however, the claims of the '983 Patent were almost
 2 indistinguishable from those in OptoLum's '536 Patent that issued in 2003. As alleged in
 3 paragraph 101 *supra*, Mr. Dry made the existence of this patent very clear to all of the
 4 attendees at the LED lighting conferences in 2003 to 2005, including Cree.
 5

U.S. Patent No. 8,752,983 (Cree)	U.S. Patent No. 6,573,536 (OptoLum)
<p style="text-align: center;"><i>1. A lamp comprising: an optically transmissive enclosure and</i></p>	<p style="text-align: center;"><i>1. A light source comprising: [Almost every bulb since Thomas Edison has “an optically transmissive enclosure”]</i></p>
<p><i>a base defining an axis of the lamp that extends from the base to the enclosure;</i></p> <p><i>an LED array disposed in a center of the optically transmissive enclosure operable to emit light when energized through an electrical connection, comprising a submount made of a thermally conductive material supporting a plurality of LEDs arranged in a band about the axis of the lamp;</i></p> <p><i>a gas contained in the enclosure to provide thermal coupling to the LED array; and</i></p> <p><i>a heat sink structure thermally coupled to the LED array for transmitting heat from the LED array to the gas.</i></p>	<p><i>an elongate thermally conductive member having an outer surface;</i></p> <p><i>at least one light emitting diodes carried on said elongate member outer surface;</i></p> <p><i>one or more electrical conductors carried by said elongate thermally conductive member and connected to said at least one light emitting diodes to supply electrical power thereto; and</i></p> <p><i>said elongate thermally conductive member being configured to conduct heat away from said at least one light emitting diode to fluid contained by said elongate thermally conductive member.</i></p>

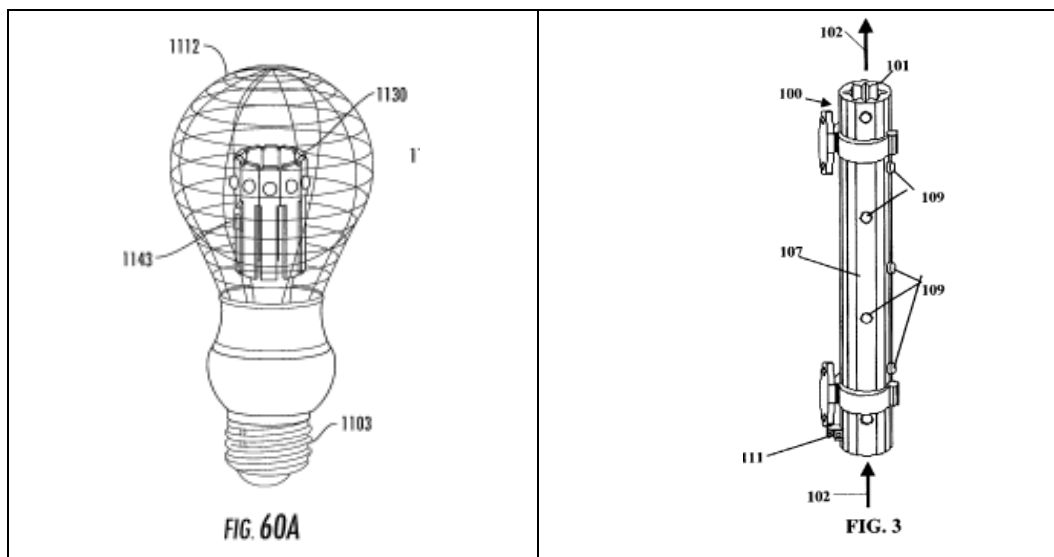

154. Despite these obvious similarities, Cree never cited the '536 Patent or indeed any of the OptoLum patents in connection with its extensive prosecution of the Cree LED Bulb Patents or any other patents derived from their 2012 provisionals.

155. Moreover, neither Cree nor Mr. Swoboda or Dr. Edmond, both of whom were listed as co-inventors on the '983 Patent, cited any publicly-available literature regarding OptoLum's BrightLife™ bulb despite, again, having seen the OptoLum BrightLife™ bulb at various tradeshows in 2003 – 2005, and having been present during presentations by Mr. Dry when he discussed how the bulb worked as well as the fact that it was patented.

156. The failure to do so was in violation of Cree's as well as Mr. Swoboda's and Dr. Edmond's duty under 37 C.F.R. § 1.56 "to disclose to the USPTO all of the prior art that is 'material to patentability' of the patent application of which each of the applicants or co-inventors is aware."

157. This failure is particularly troubling given the fact that both prior to and contemporaneously with the prosecution of both the '983 patent and Cree LED Bulb Patents, Cree was, in fact, on at least on two occasions, reminded of the '536 Patent in connection with

1 the prosecution of other Cree's patent applications before the USPTO, and did, in fact, cite the
2 '536 Patent as being material to patentability in connection with at least two other Cree patent
3 applications.

4 158. First, on April 25, 2012, in a Non-Final Rejection of Cree's U.S. Patent
5 Application No. 12/582,206, that eventually issued as U.S. Patent No. 9,243,758, a USPTO
6 Examiner cited the '536 Patent as relevant prior art, thereby giving Cree a reason to review the
7 '536 Patent, for at least this purpose.

8 159. Second, on September 15, 2013, in connection with a prosecution of Cree's U.S.
9 Patent Application No. 13/691,934, that eventually issued as U.S. Patent No. 8,789,977, the
10 Patent Office notified Cree of an Information Disclosure Statement (IDS) filed by a third party
11 under 37 C.F.R. § 1.290, that not only cited OptoLum's '536 Patent as a relevant prior art, but
12 also provided a detailed claim chart highlighting particular features and teachings of the '536
13 Patent that were directly material not only to the subject patent application but to the Cree LED
14 Bulb Patents as well.

15 160. Yet again, on December 18, 2014, the '536 Patent was cited to the USPTO as
16 material to patentability during prosecution of Cree's patent application that issued into U.S.
17 Patent No. 9,030,120, and once more, on April 3, 2015, in connection with the prosecution of a
18 patent application that issued into U.S. Patent No. 9,217,542.

19 THE SUCCESS OF CREE'S COVERT PLAN

20 161. As alleged in paragraph 23 *supra*, Cree's branding strategy was and remains to
21 this day, hugely successful.

1 162. Mr. Swoboda has stated that Cree's share of voice for LED bulbs went from zero
2 to 80% with its share of voice for LED lighting fixtures increasing from 10% to over 60% and
3 that the overall voice increased by a factor of 2.5 within a month of the initial product release.

4 163. In addition, Mr. Swoboda has estimated that the ads and the resulting publicity
5 created branding for Cree worth \$1 billion a year for 5 years.

6 164. Within a day of the first ad, Cree's stock shot up from \$45 to \$51 per share. A few
7 months later, Cree's stock was trading at \$69 per share.

8 165. Sales in Cree's Lighting Product segment, which, upon information and belief,
9 consists primarily of LED lighting products and bulbs, also increased from approximately \$337
10 million for the fiscal year ending on June 24, 2012 to \$495 million, \$706.4 million, \$906.5
11 million and \$889.1 million in subsequent years.

12 166. The simple and inescapable truth, however, is that these ads were and continue to
13 be false and, on information and belief, are known by Cree to be false, on many levels.

14 167. In the first place, as alleged above, the LED bulb is the culmination of over a
15 century of hard work and discovery by hundreds of talented engineers and scientists from all
16 over the world.

17 168. Kudos in recent years must surely go to Mr. Nakamura, Isao Akasaki and Hiroshi
18 Amano who received the Nobel Prize in 2014 for their work in the mid-1990s with blue LEDs.
19 The creation of the high-power white LED with a direct thermal pad by Lumileds in the late-
20 1990s and years before Cree had built its first high-power white LED was, without question, a
21 major milestone as well.

22 169. Cree's claims that it created the first LED bulb with the technology embodied in
23 the so-called Cree Filament Tower™ that enabled its bulb to have a long useful life and to
24

1 produce centralized, omnidirectional light similar to an incandescent bulb is perhaps, however,
2 the most egregious falsehood of all.

3 170. Indeed, Cree knew and had known for years that this distinction belonged to Mr.
4 Dry and OptoLum as well as the fact that OptoLum's LED bulb was patented.
5

6 **COUNT 1**

7 **(VIOLATION OF THE LANHAM ACT, 15 U.S.C. §§ 1051, ET SEQ., FALSE**
8 **ADVERTISING)**

9 171. OptoLum repeats and realleges the allegations contained in paragraphs 1–170
10 above as if fully set forth herein.
11

12 172. In addition to the allegations more specifically set forth in paragraphs 122–125
13 *supra*, Cree continues to claim that it created the first LED replacement to the incandescent
14 bulb as well as the technology embodied in the Cree Filament Tower™.

15 173. For example, Mr. Swoboda stated during interviews in March 2013 that Cree
16 “found a way to put the LEDs in the center of the bulb like a traditional light bulb” and that
17 “we’re making an LED bulb, but we are actually inventing all the technology in between.”
18

19 174. David Elien, Vice President of Marketing and Business Development for Cree,
20 stated in November 2013 that “one of the technical breakthroughs that enabled Cree to break
21 the \$10 threshold is our new Cree LED Filament Tower™ Technology. The Filament Tower™
22 is the Cree innovation that lets our LED bulb replicate the look and feel of filament based
23 traditional lights.”

24 175. Mike Watson, Vice President of Cree Product Strategy, stated in April 2016 that
25 “our engineers came up with a very elegant solution to the design issues inherent in LED
26
27
28

1 bulbs. In a compact form, the Filament Tower™ produced the light dispersion we wanted
2 without problematic heat building.”

3 176. Currently, Cree’s webpage states that “[i]nventing the LED technology that
4 delivers light like an incandescent was hard work, but designing a bulb in a form-factor that
5 consumers trust at a price they can afford was even harder. Designed with Cree LED Filament
6 Tower™ Technology, the Cree LED bulb represents a breakthrough in LED bulb design and
7 performance.”

8
9 177. Even the packaging for bulbs Cree is selling at the present time falsely states that
10 Cree “invented the lighting-class LED”—a distinction that, as discussed at paragraph 70 *supra*,
11 actually belongs to Lumileds.

12 178. Cree has therefore made or caused to be made, and continues to make, false
13 and/or misleading statements in commercial advertising and into interstate commerce
14 regarding the nature, characteristics and qualities of its LED bulb in violation of Section 43(a)
15 of the Lanham Act, 15 U.S.C. §§ 1051, *et seq.*

16
17 179. Cree has also used and continues to use deceptive common law trademarks,
18 “Filament Tower™” and “Filament Tower™ Technology,” that mislead or deceive consumers
19 into believing that Cree created the technology that extended the useful life of its bulbs and
20 enabled them to produce omnidirectional light of similar in quality to traditional incandescent
21 bulbs.

22
23 180. Moreover, the use of these phrases, capitalized and in conjunction with the Cree
24 company name, falsely implies that Cree created technology embodied by the Filament
25 Tower™ to the exclusion of all others, including OptoLum, whose founder and CEO, Mr. Dry,
26
27
28

1 actually created this technology also in violation of Section 43(a) of the Lanham Act, 15
2 U.S.C. §§ 1051, *et seq.*

3 181. These statements are literally false or false by necessary implication.

4 182. These false statements were aimed at potential customers for LED bulbs as well
5 as LED fixtures and lighting products and actually deceived or tended to deceive a substantial
6 number of these customers.

7 183. These false statements actually or likely influenced customer decisions to
8 purchase LED bulbs as well as LED fixtures and lighting products from Cree and were
9 therefore material to the purchasing decision.

10 184. OptoLum competes with Cree for the sale of LED fixtures and lighting products.

11 185. There is significant value to being perceived by potential customers as an
12 inventor, innovator, and the first to have created a groundbreaking product such as, for
13 example, the technology that enabled the first LED replacement to incandescent bulbs.
14

15 186. Cree's false statements deceive, or have the tendency to deceive, OptoLum's and
16 Cree's customers and potential customers about who created the technology that enabled a
17 long useful life LED bulb capable of producing omnidirectional light similar in quality to
18 traditional incandescent bulbs.
19

20 187. As a result of Cree's false statements, OptoLum has suffered competitive injury
21 in the form of lost sales and a loss of goodwill and reputation associated with its name and
22 products.
23

24 188. Further, as a result of Cree's false statements, OptoLum has lost the opportunity
25 to generate the goodwill and reputation that would have developed had consumers of LED
26
27
28

1 fixtures and lighting products correctly perceived of Mr. Dry and OptoLum as the inventors of
2 the technology.

3 189. For at least these reasons, OptoLum has been harmed by Cree's false statements.

4 190. Upon information and belief, Cree made these statements and used misleading
5 common law trademarks knowing that they were false and with the intent to deceive or in
6 reckless disregard of whether the statements were, in fact, true.
7

8 191. Cree's wrongful conduct is exceptional and entitles OptoLum to attorney's fees
9 and costs incurred in prosecuting this action under 15 U.S.C. § 1117.
10

11 **COUNT 2**

12 **(UNJUST ENRICHMENT)**

13 192. OptoLum repeats and realleges the allegations contained in paragraphs 1–191
14 above as if fully set forth herein.
15

16 193. As alleged in paragraph 185 *supra*, there is significant value to being perceived by
17 potential customers as an inventor, innovator, and the first to have created a groundbreaking
18 product such as, for example, the technology that enabled LED bulbs to have a long useful life
19 and produce omnidirectional light similar in quality to and thereby serve as a replacement to
20 incandescent bulbs.
21

22 194. The reputation for having done so properly belongs to OptoLum and not Cree.

23 195. Cree never obtained OptoLum's permission nor offered to pay OptoLum for the
24 right to take advantage of this reputation.

25 196. Cree wrongfully appropriated this reputation for itself at the expense of OptoLum.

26 197. As a consequence, Cree has been unjustly enriched.
27
28

COUNT 3

(INFRINGEMENT OF U.S. PATENT NO. 6,831,303)

198. OptoLum repeats and realleges the allegations contained in paragraphs 1–197 above as if fully set forth herein.

THE DISCLOSURE OF THE '303 AND '028 PATENTS

199. Because the '303 Patent and the '028 Patent are continuations of the '536 Patent, each sharing the same priority date and patentable subject matter, reference will be made to the detailed description of the '303 Patent with the understanding that the same patentable subject matter will also be found in the '028 Patent.

200. The '303 Patent, like the '028 Patent, is entitled “LIGHT EMITTING DIODE LIGHT SOURCE” and is directed to “*lighting sources, in general, and to a lighting source that utilizes Light Emitting Diodes (LED’s), in particular.*”¹ The focus of the disclosure of this patent is summarized in the last sentence of the Background section, which states that it is “*desirable to provide an LED light source that efficiently conducts heat away from the LED’s.*”²

201. The Background of the '303 Patent discusses the shortcomings of LED technology prior to the invention pointing out that the LED light sources at the time were limited to “*specialized light sources such as ... vehicle brake lights, ... vehicle related lighting and ... flashlights.*”³ The Background section notes that LEDs were “[t]ypically ... not used to provide illumination, but [rather] to provide signaling.”⁴ and explains why this was so:

¹ Ex. A at 1:9-11.

² Ex. A at 1:36-37.

³ Ex. A at 1:16-18.

⁴ Ex. A at 1:21-23.

1 One problem that has limited the use of LED's to specialty
2 signaling and limited general illumination sources is that LED's
3 typically generate significant amounts of heat. The heat is such that
4 unless the heat is dissipated, the LED internal temperature will rise
5 causing degradation or destruction of the LED. It is therefore
6 further desirable to provide an LED light source that efficiently
7 conducts heat away from the LED's.⁵

8 202. This meant that in order to create an LED light source having sufficient light
9 output to be used "*as a general lighting source,*" it would be necessary to create a heat
10 management system that could efficiently dissipate the heat generated by the LEDs to ensure
11 that the LEDs do not overheat and thereby extend their useful life.

12 203. The Background of the '303 Patent further explains that the "attempts to provide
13 LED light sources as sources of illumination have been few and generally unsatisfactory from
14 a general lighting standpoint."⁶ For this reason, "*[i]t is highly desirable to provide a light
15 source utilizing LEDs that provides sufficient light output so as to be used as a general lighting
16 source rather than as a signaling source.*"⁷ Signaling sources, by contrast, did not emit as
17 much light as the general lighting sources and therefore, did not have the same thermal
18 management problems to overcome.

19 204. The '303 Patent goes on to present an LED lamp/bulb whose heat management
20 system solves the problem of excessive heat making it suitable "*as a general illumination
21 device.*"⁸

22 205. More particularly, the '303 Patent states:

23 [t]he light source [that] includes an elongate thermally conductive
24 member having an outer surface. A plurality of light emitting
25 diodes is carried on the elongate member outer surface. At least

26 ⁵ Ex. A at 1:30-37.

27 ⁶ Ex. A at 1:24-26.

28 ⁷ Ex. A at 1:27-29.

⁸ Ex. A at 2:58.

1 some of the light emitting diodes are disposed in a first plane and
2 others of said light emitting diodes are disposed in a second plane
3 not coextensive with the first plane. Electrical conductors are
4 carried by the elongate thermally conductive member and are
5 connected to the plurality of light emitting diodes to supply
6 electrical power thereto. The elongate thermally conductive
7 member conducts heat away from the light emitting diodes.⁹

8 206. The '303 Patent further states that "*an illustrative embodiment of the invention*
9 *utilizes light emitting diodes that emit white light,*"¹⁰ and that "*the elongate thermally*
10 *conductive member transfers heat from the light emitting diodes to a medium within said*
11 *elongate thermally conductive member,*" which, "*[i]n the illustrative embodiment, ... is air.*"¹¹

12 207. The '303 Patent also describes that "*an elongate thermally conductive member or*
13 *heat sink 101*"¹² is formed using "*a material that provides excellent thermal conductivity*"¹³
14 which is "*configured to provide convective heat dissipation and cooling.*"¹⁴ The '303 Patent
15 states that the "*tubular heat sink 101 is hollow and has an interior cavity 103,*"¹⁵ and that
16 "*convective cooling is provided by movement of a medium 102 through elongate heat sink*
17 *101.*"¹⁶ The '303 Patent further notes that "*[i]n the illustrative embodiment shown, convection*
18 *cooling by flow of air through tubular heat sink 101 is utilized such that cool or unheated air*
19 *enters tubular heat sink 101 at its lower end and exits from the upper end as heated air.*"¹⁷

20
21
22
23 ⁹ Ex. A at 1:41-53.

24 ¹⁰ Ex. A at 1:54-55.

25 ¹¹ Ex. A at 1:61-64.

26 ¹² Ex. A at 2:60-61.

27 ¹³ Ex. A at 2:61-62.

28 ¹⁴ Ex. A at 2:66-67.

¹⁵ Ex. A at 2:67 – 3:2.

¹⁶ Ex. A at 3:5-7.

¹⁷ Ex. A at 3:65 – 4:1.

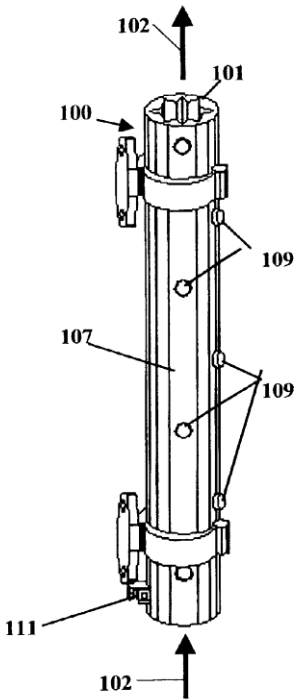

FIG. 3

FIG. 3 of the '303 Patent

208. The '303 Patent also discusses the fact that “*the elongate thermally conductive member has one or more fins to enhance heat transfer to the medium.*”¹⁸ In the embodiment that is “*more clearly seen in FIG. 2, tubular heat sink 101 is hollow and has an interior cavity 103 that includes one or more heat dissipating fins 105. Fins 105 are integrally formed on the interior of elongate heat sink 101.*”¹⁹ The '303 Patent further points out that “[*f*]ins 105 may vary in number and location depending on particular LED layouts and wattage,” and that “*fins may be added to the exterior surface of tubular heat sink 101.*”²⁰

¹⁸ Ex. A at 1:65-67.

¹⁹ Ex. A at 2:67 – 3:5.

²⁰ Ex. A at 3:51-54.

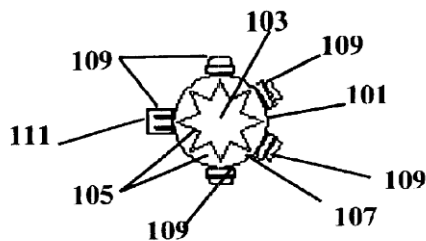

FIG. 2

FIG. 2 of the '303 Patent

209. The configuration of the LED light source of the '303 Patent providing a multi-directional light distribution is evident throughout the specification. For instance, even the Abstract states that the “*light emitting diodes that emit white light ... [are] mounted on an elongate member having at least two surfaces.*” In addition, the detailed description of the '303 Patent discloses that “*a plurality of light emitting diodes is carried on the elongate member outer surface. At least some of the light emitting diodes are disposed in a first plane and others of said light emitting diodes are disposed in a second plane not coextensive with the first plane.*”²¹ Further, the '303 Patent explains that a “[*t*]ubular heat sink 101 in the illustrative embodiment is formed in the shape of a polygon and may have any number of sides”²² and that “[*t*]he exterior surface 107 of elongate heat sink 101 has a plurality of Light Emitting Diodes 109 disposed thereon.”²³ Lastly, the '303 Patent states that “[*f*]lexible printed circuit 113 has LEDs 109 mounted to it in a variety of orientations ranging from 360 degrees to 180 degrees and possibly others depending on the application.”²⁴

210. The multi-directional light distribution of the LED light source of the '303 Patent is also clearly illustrated in the drawings of the '303 Patent. For instance, FIGS. 2, 3 and 5,

²¹ Ex. A at 1:44-48.

²² Ex. A at 3:46-48.

²³ Ex. A at 3:11-12.

²⁴ Ex. A at 3:31-34.

1 among others, each show the LEDs 109 of the elongated heat sink 101 disposed on a tubular
 2 heat sink 101 and configured to emit light outwards in multiple directions, providing a multi-
 3 directional light source.

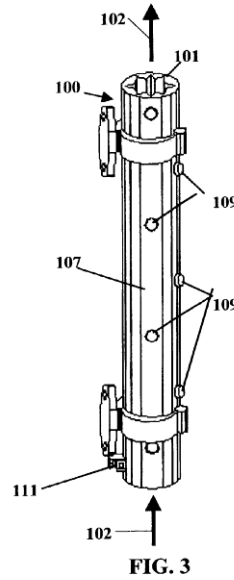
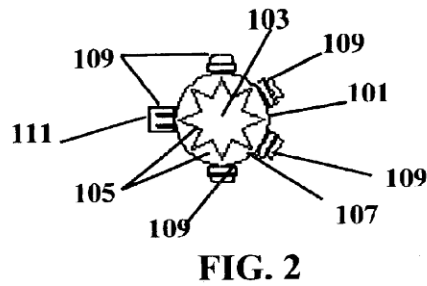

14 For clarity, FIGS. 2 and 3 of the '303 Patent.

15
 16 211. The '303 Patent also describes the configuration of the elongated heat sink 101 to
 17 efficiently conduct the heat away from the LEDs to the fluid within the elongated heat sink
 18 101. This configuration is accomplished not only by distributing the LEDs all around the heat
 19 sink 101, thus increasing the heat sink's effectiveness in distributing the heat away from the
 20 LEDs, but also by ensuring that the back planes of the LEDs are maintained in a "thermal
 21 contact" with the heat sink 101, maximizing the amount of heat that is dissipated from the
 22 LEDs. The '303 Patent explains that "*the elongate thermally conductive member transfers heat
 23 from the light emitting diodes to a medium within said elongate thermally conductive
 24 member.*"²⁵

25
 26
 27 ²⁵ Ex. A at 1:61-63.

1 212. The '303 Patent teaches maintaining a thermal contact between the LEDs and the
 2 heat sink, even when a printed circuit board is used, stating that “each of the light emitting
 3 diodes is ... affixed in thermally conductive contact with said elongate thermally conductive
 4 member.”²⁶ This is further described by the '303 Patent with reference to an exemplary
 5 “[f]lexible printed circuit 113 ... [having] mounting holes 134 for receiving LEDs 109 such
 6 that the backs of LEDs 109 are in thermal contact with the tube surface 107.”²⁷ Maintaining
 7 the LEDs in the thermal contact with the heat sink 101 is also shown in FIG. 6 illustrating an
 8 embodiment in which the back of an LED 109 is placed in physical contact with the heat sink
 9 101, thereby exemplifying a direct thermal contact between the heat sink 101 and LED 109.
 10

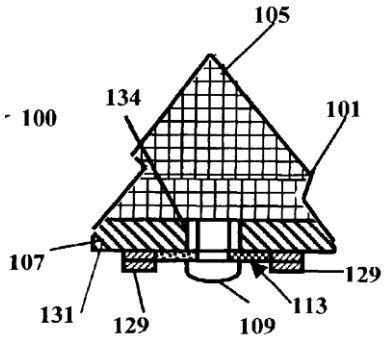

FIG. 6

FIG. 6 of the '303 Patent.

THE '303 PATENT ALLEGATIONS

213. OptoLum repeats and realleges the allegations contained in paragraphs 1–212
 above as if fully set forth herein.

²⁶ Ex. A at 2:27-29.

²⁷ Ex. A at 3:43-45.

1 214. OptoLum is the owner, by assignment, of all right, title and interest in and to the
2 '303 Patent, entitled "LIGHT EMITTING DIODE LIGHT SOURCE" that issued on December
3 14, 2004. (Ex. A.)

4 215. The '303 Patent is valid and enforceable.



5 216. Cree has infringed and is infringing, either literally or under the doctrine of
6 equivalents, the '303 Patent in violation of 35 U.S.C. §§ 271 *et seq.*, by making, using, offering
7 for sale/lease, selling or leasing in the United States and/or importing into the United States
8 without authority or license, at least the Accused Products. Cree may have infringed the '303
9 Patent through other instrumentalities utilizing the same or reasonably similar functionality,
10 including, without limitation, other versions of the Cree LED light bulb, or other residential or
11 commercial LED fixtures and lighting products, each of which may be, upon further inspection
12 and discovery, included in the Accused Products. Specifically, the Accused Products, which
13 are meant to be exemplary and not exhaustive, infringe at least claims: 2, 3, 4, 6, 7, 8, 9, 10, 11,
14 12 and 13 of the '303 Patent.

15 217. On information and belief after reasonable investigation, each of the Accused
16 Products comprises all of the elements of claim 2 of the '303 Patent. Claim 2 of the '303 Patent
17 recites:

18 a light source comprising: an elongate thermally conductive
19 member having an outer surface; a plurality of light emitting
20 diodes carried on said elongate member outer surface at least some
21 of said light emitting diodes being disposed in a first plane and
22 others of said light emitting diodes being disposed in a second
23 plane not coextensive with said first plane; electrical conductors
24 carried by said elongate thermally conductive member and
25 connected to said plurality of light emitting diodes to supply
26 electrical power thereto; and said elongate thermally conductive
27 member being configured to conduct heat away from said light
28 emitting diodes to fluid contained by said elongate thermally
conductive member; said elongate thermally conductive member

comprises one or more heat dissipation protrusions . . . at least one of said heat dissipation protrusions being carried on said elongate member outer surface.

218. More specifically, as shown in the pictures of an exemplary Accused Product below, the Accused Products include each and every element of claim 2 of the '303 Patent.

<p><i>A light source comprising:</i></p>	<p>As shown in the photo, the exemplary Accused Product is a white LED 40W incandescent replacement light bulb (“the Exemplary Cree LED Bulb”) that includes a light source.</p> <div style="display: flex; justify-content: space-around; align-items: center;"> <div style="text-align: center;">  <p>A package of an Exemplary Cree LED Bulb.</p> </div> <div style="text-align: center;">  <p>The Exemplary Cree LED Bulb emits light.</p> </div> </div>
--	--

1
2
3
4
5
6
7
8
9
10
11
12
13
14
15
16
17
18
19
20
21
22
23
24
25
26
27
28

*an elongate thermally
conductive member
having an outer surface;*

As shown in this photo, the exemplary Accused Product includes an elongate thermally conductive member having an outer surface.

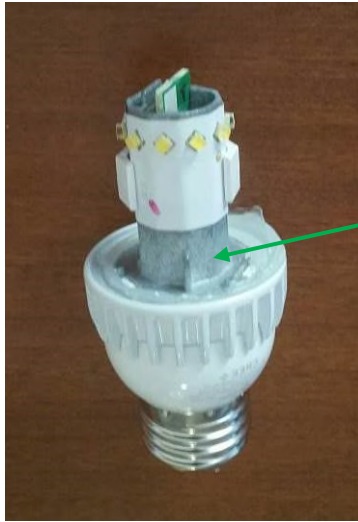

Elongate thermally
conductive member of the
Exemplary Cree LED Bulb
having an outer surface

*a plurality of light
emitting diodes carried on
said elongate member
outer surface*

As shown this photo, the exemplary Accused Product includes a plurality of light emitting diodes carried on said elongate member outer surface.

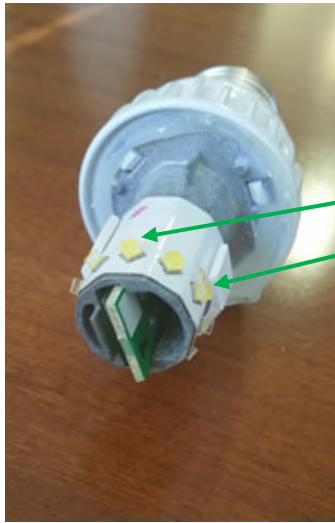

Plurality of LEDs carried
on said elongate member
outer surface

1 *at least some of said light*
2 *emitting diodes being*
3 *disposed in a first plane*
4 *and others of said light*
5 *emitting diodes being*
6 *disposed in a second*
7 *plane not coextensive with*
8 *said first plane;*

As shown in this photo, on information and belief, the exemplary Accused Product includes at least some of said light emitting diodes being disposed in a first plane and others of said light emitting diodes being disposed in a second plane not coextensive with said first plane.

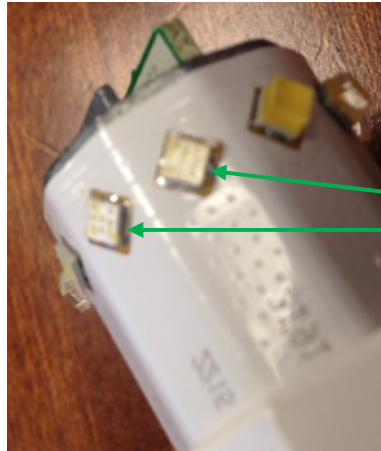

On information and belief, within each LED package, there is a plurality of LEDs. LED packages are disposed in a plurality of planes, not coextensive with each other.

13 *electrical conductors*
14 *carried by said elongate*
15 *thermally conductive*
16 *member and connected to*
17 *said plurality of light*
18 *emitting diodes to supply*
19 *electrical power thereto;*

As shown this photo, on information and belief, the exemplary Accused Product includes electrical conductors carried by said elongate thermally conductive member and connected to said plurality of light emitting diodes to supply electrical power thereto.

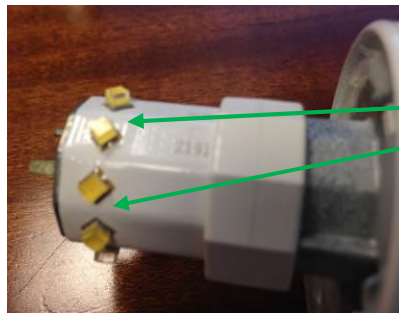

On information and belief, there are electrical conductors connected to the plurality of LEDs for supplying power to the LEDs.

28

1 *and said elongate*
 2 *thermally conductive*
 3 *member being configured*
 4 *to conduct heat away from*
 5 *said light emitting diodes*
 6 *to fluid contained by said*
 7 *elongate thermally*
 8 *conductive member;*

As shown in this photo, on information and belief, the exemplary Accused Product includes said elongate thermally conductive member being configured to conduct heat away from said light emitting diodes to fluid contained by said elongate thermally conductive member.

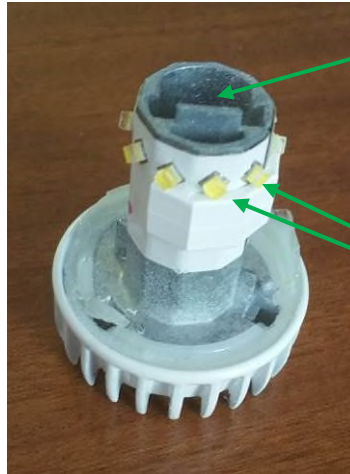

There is fluid contained by the hollow elongate thermally conductive member of the Exemplary Cree LED bulb.

On information and belief, the elongate thermally conductive member of the Exemplary Cree LED Bulb is configured to conduct the heat away from the LEDs to the fluid within the member.

12 *said elongate thermally*
 13 *conductive member*
 14 *comprises one or more*
 15 *heat dissipation*
 16 *protrusions, at least one*
 17 *of said heat dissipation*
 18 *protrusions being carried*
 19 *on said elongate member*
 20 *outer surface.*

As shown in this photo, the exemplary Accused Product includes said elongate thermally conductive member comprising one or more heat dissipation protrusions, at least one of said heat dissipation protrusions being carried on said elongate member outer surface.



The elongate thermally conductive member comprises one or more heat dissipation protrusions on the outer surface of the member.

1 219. The above allegations are based on public information and investigation
2 conducted prior to the commencement of this case and prior to discovery. As such, these
3 allegations do not constitute complete infringement contentions and OptoLum reserves the
4 right to modify these and other related allegations after a reasonable opportunity for further
5 investigation and discovery.
6

7 220. This Complaint will serve as notice to Cree of the '303 Patent and its
8 infringement should Cree contend that they did not previously have knowledge thereof.

9 221. OptoLum has been damaged by Cree's infringement of the '303 Patent.
10 Moreover, as a result of Cree's infringement of the '303 Patent, OptoLum has suffered injury
11 to its sales as well as to its good will and reputation and will continue to be damaged unless
12 Cree is enjoined by this Court. OptoLum has suffered and continues to suffer irreparable injury
13 for which there is no adequate remedy at law. The balance of hardships favors OptoLum, and
14 public interest in encouraging and protecting innovation will be served by an injunction.
15

16 222. OptoLum is entitled to recover from Cree all damages that OptoLum has
17 sustained as a result of Cree's infringement of the '303 Patent, including, without limitation, a
18 reasonable royalty.
19

20 WILLFUL INFRINGEMENT OF THE '303 PATENT

21 223. OptoLum repeats and realleges the allegations contained in paragraphs 1–222
22 above as if fully set forth herein.

23 224. As alleged in paragraphs 216-218 *supra*, Cree infringes the '303 Patent.

24 225. As alleged in paragraph 199, *supra*, the '303 Patent is a child of the '536 Patent,
25 and issued in December, 2004.
26
27
28

1 226. Further, as alleged in paragraphs 150–160 *supra*, on April 25, 2012, during
2 prosecution of Cree’s patent application that issued into U.S. Patent No. 9,243,758, a USPTO
3 examiner cited the ’536 Patent as material to patentability of the pending Cree application.

4 227. Then again, on September 13, 2013, during the prosecution of Cree’s patent
5 application that issued into U.S. Patent No. 8,789,977, a third party submitted the ’536 Patent
6 for consideration by the examiner, including a detailed discussion of the similarities between
7 the pending Cree application and the ’536 Patent.

8 228. Yet again, the ’536 Patent was cited in an IDS to the USPTO as relevant to
9 patentability on December 18, 2014, during prosecution of Cree’s patent application that issued
10 into U.S. Patent No. 9,030,120, and once more, on April 3, 2015, in connection with the
11 prosecution of a patent application that issued into U.S. Patent No. 9,217,542.

12 229. The existence of the ’303 Patent as a child of the ’536 Patent would have been
13 readily apparent from even a cursory examination of the publicly available information
14 regarding the ’536 Patent such as Public Pair and Google Patents.

15 230. Therefore, Cree knew or should have known of the ’303 Patent before the date of
16 first infringement and is therefore liable for willfully infringing the ’303 Patent.

17 231. Cree’s infringement of the ’303 Patent was willful and deliberate, entitling
18 OptoLum to enhanced damages and attorney’s fees.

19 232. Additional allegations regarding Cree’s knowledge of the ’303 Patent and willful
20 infringement will likely have evidentiary support after a reasonable opportunity for discovery.

21 233. Cree’s infringement of the ’303 Patent is exceptional and entitles OptoLum to
22 attorney’s fees and costs incurred in prosecuting this action under 35 U.S.C. § 285.
23
24
25
26
27
28

COUNT 4

(INFRINGEMENT OF U.S. PATENT NO. 7,242,028)

234. OptoLum repeats and realleges the allegations contained in paragraphs 1–233 above as if fully set forth herein.

235. OptoLum is the owner, by assignment, of all right, title and interest in and to the '028 Patent, entitled “LIGHT EMITTING DIODE LIGHT SOURCE” that issued on July 10, 2007. (Ex. B.)

236. The '028 Patent is valid and enforceable.

237. Cree has infringed and is infringing, either literally or under the doctrine of equivalents, the '028 Patent in violation of 35 U.S.C. §§ 271 *et seq.*, by making, using, offering for sale/lease, selling or leasing in the United States and/or importing into the United States without authority or license, at least the Accused Products. Cree may have infringed the '028 Patent through other instrumentalities utilizing the same or reasonably similar functionality, including, without limitation, other versions of the Cree LED light bulb, or other residential or commercial LED fixtures and lighting products, each of which may be, upon further inspection and discovery, included in the Accused Products. Specifically, the Accused Products, which are meant to be exemplary and not exhaustive, infringe at least claims 19, 20, 21, 22, 23, 24, 25, 26, 27, 28 and 29 of the '028 Patent.

238. On information and belief after reasonable investigation, each of the Accused Products comprises all of the elements of claim 19 of the '028 Patent. Claim 19 of the '028 Patent recites:

a radiation emitting source, comprising: an elongate thermally conductive member having an outer surface; a plurality of radiation emitting semiconductor devices carried on said elongate member outer surface at least some of said radiation emitting

1
2
3
4
5
6
7
8
9
10
11
12
13
14
15
16
17
18
19
20
21
22
23
24
25
26
27
28

sources being disposed in a first plane and others of said radiation emitting semiconductor devices being disposed in a second plane not coextensive with said first plane; electrical conductors carried by said elongate thermally conductive member and connected to said plurality of radiation emitting semiconductor devices to supply electrical power thereto; and said elongate thermally conductive member being configured to conduct heat away from said radiation emitting semiconductor devices to fluid contained by said elongate thermally conductive member; said elongate thermally conductive member comprises one or more heat dissipation protrusions; at least one of said heat dissipation protrusions being carried on said elongate member outer surface; said elongate thermally conductive member is configured to conduct heat away from said radiation emitting semiconductor devices to fluid proximate said elongate member outer surface; and said elongate thermally conductive member comprises a tube.

239. More specifically, as shown in the pictures of an exemplary Accused Product below, the Accused Products include each and every element of claim 19 of the '028 Patent.

1 *A radiation emitting*
2 *source, comprising:*

As shown in this photo, the exemplary Accused Product having a package describing a Cree daylight white LED 40W incandescent replacement bulb (“Exemplary Cree LED Bulb”) includes a radiation emitting source.

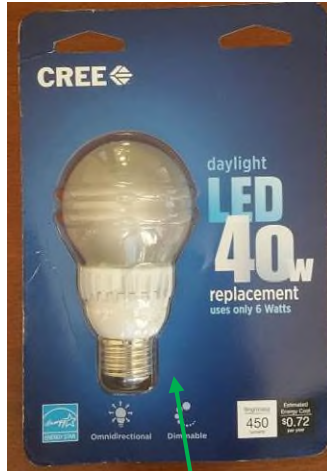

12
13
14
15
16

A package of an Exemplary Cree LED Bulb.

The Exemplary Cree LED Bulb emits light, which is a form of radiation.

17 *an elongate thermally*
18 *conductive member*
19 *having an outer surface;*

As shown in this photo, the exemplary Accused Product includes an elongate thermally conductive member having an outer surface.

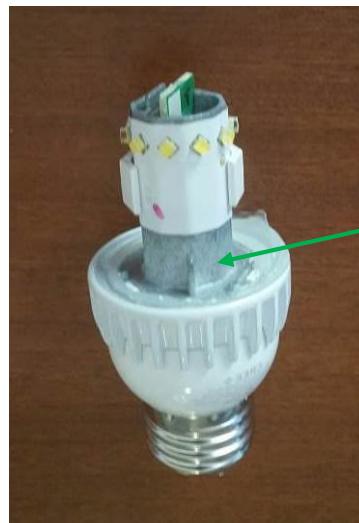

Elongate thermally conductive member of the Exemplary Cree LED Bulb having an outer surface

1
2
3
4
5
6
7
8
9
10
11
12
13
14
15
16
17
18
19
20
21
22
23
24
25
26
27
28

a plurality of radiation emitting semiconductor devices carried on said elongate member outer surface

As shown this photo, the exemplary Accused Product includes a plurality of radiation emitting semiconductor devices carried on said elongate member outer surface.

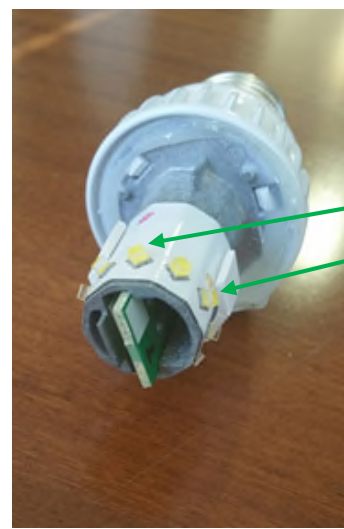

Plurality of LEDs carried on said elongate member outer surface. LEDs emit light, which is a form of radiation.

at least some of said radiation emitting sources being disposed in a first plane and others of said radiation emitting semiconductor devices being disposed in a second plane not coextensive with said first plane;

As shown in this photo, the exemplary Accused Product includes at least some of said radiation emitting sources being disposed in a first plane and others of said radiation emitting semiconductor devices being disposed in a second plane not coextensive with said first plane.

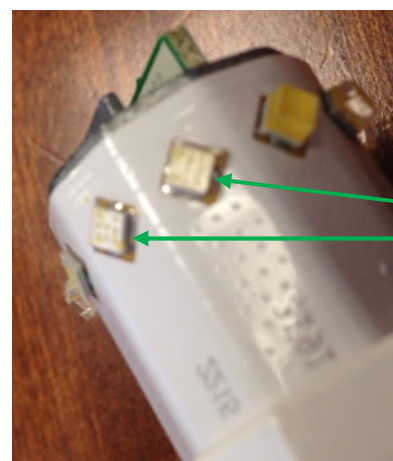

On information and belief, within each LED package, there is a plurality of LEDs. LED packages are disposed in a plurality of planes, not coextensive with each other.

1 *electrical conductors*
2 *carried by said elongate*
3 *thermally conductive*
4 *member and connected to*
5 *said plurality of radiation*
6 *emitting semiconductor*
7 *devices to supply*
8 *electrical power thereto;*
9 *and*

As shown in this photo, the exemplary Accused Product includes electrical conductors carried by said elongate thermally conductive member and connected to said plurality of radiation emitting semiconductor devices to supply electrical power thereto.

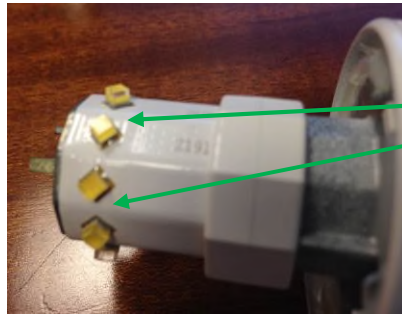

On information and belief, there are electrical conductors connected to the plurality of LEDs for supplying power to the LEDs.

10 *said elongate thermally*
11 *conductive member being*
12 *configured to conduct*
13 *heat away from said*
14 *radiation emitting*
15 *semiconductor devices to*
16 *fluid contained by said*
17 *elongate thermally*
18 *conductive member;*

As shown in this photo, on information and belief, the exemplary Accused Product includes said elongate thermally conductive member being configured to conduct heat away from said radiation emitting semiconductor devices to fluid contained by said elongate thermally conductive member.

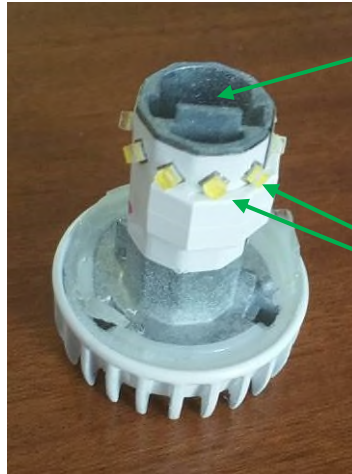

There is fluid contained by the hollow elongate thermally conductive member of the Exemplary Cree LED Bulb.

On information and belief, the elongate thermally conductive member of the Exemplary Cree LED Bulb is configured to conduct the heat away from the LEDs to the fluid within the member.

28

1 *said elongate thermally*
2 *conductive member*
3 *comprises one or more*
4 *heat dissipation*
5 *protrusions;*

As shown in this photo, the exemplary Accused Product includes said elongate thermally conductive member comprising one or more heat dissipation protrusions.

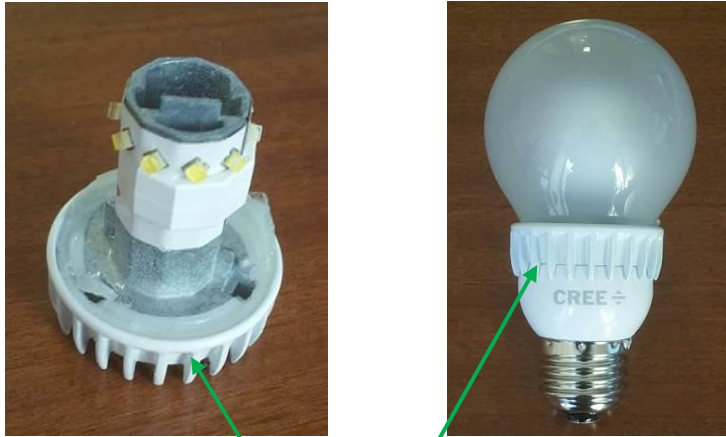

Elongate thermally conductive member comprises one or more heat dissipation protrusions.

14 *at least one of said heat*
15 *dissipation protrusions*
16 *being carried on said*
17 *elongate member outer*
18 *surface;*

As shown in this photo, the exemplary Accused Product includes at least one of said heat dissipation protrusions being carried on said elongate member outer surface.

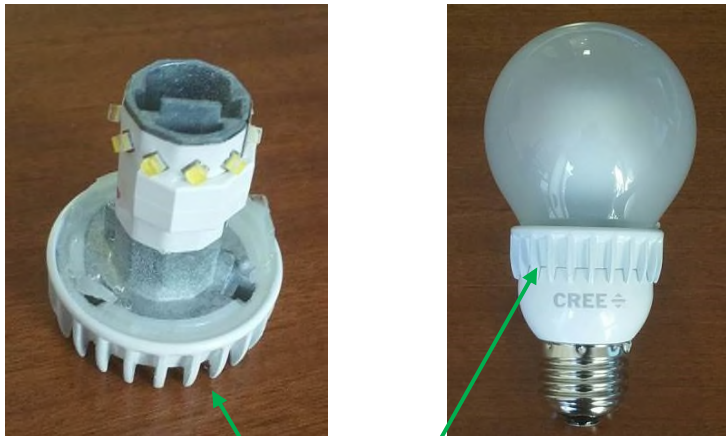

At least one of said heat dissipation protrusions is carried on said elongate member outer surface.

1 *said elongate thermally*
2 *conductive member is*
3 *configured to conduct*
4 *heat away from said*
5 *radiation emitting*
6 *semiconductor devices to*
7 *fluid proximate said*
8 *elongate member outer*
9 *surface; and*

As shown in this photo, on information and belief, the exemplary Accused Product includes said elongate thermally conductive member configured to conduct heat away from said radiation emitting semiconductor devices to fluid proximate said elongate member outer surface.

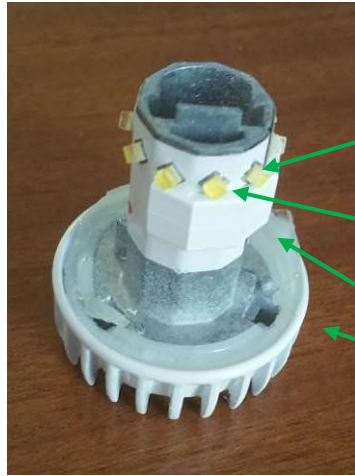

On information and belief, the elongate thermally conductive member of the Exemplary Cree LED Bulb is configured to conduct the heat away from the LEDs to the fluid proximate said elongate member outer surface.

There is fluid proximate said elongate member outer surface

12 *said elongate thermally*
13 *conductive member*
14 *comprises a tube.*

As shown in this photo, the exemplary Accused Product includes said elongate thermally conductive member comprising a tube.



Said elongate thermally conductive member comprises a tube.

21 240. The above allegations are based on public information and investigation
22 conducted prior to the commencement of this case and prior to discovery. As such, these
23 allegations do not constitute complete infringement contentions and OptoLum reserves the
24 right to modify these and other related allegations after a reasonable opportunity for further
25 investigation and discovery.
26

1 241. This Complaint will serve as notice to Cree of the '028 Patent and its
2 infringement should Cree contend that they did not previously have knowledge thereof.

3 242. OptoLum has been damaged by Cree's infringement of the '028 Patent.
4 Moreover, as a result of Cree's infringement of the '028 Patent, OptoLum has suffered injury
5 to its sales as well as to its good will and reputation and will continue to be damaged unless
6 Cree is enjoined by this Court. OptoLum has suffered and continues to suffer irreparable injury
7 for which there is no adequate remedy at law. The balance of hardships favors OptoLum, and
8 public interest in encouraging and protecting innovation will be served by an injunction.
9

10 243. OptoLum is entitled to recover from Cree all damages that OptoLum has
11 sustained as a result of Cree's infringement of the '028 Patent, including, without limitation, a
12 reasonable royalty.
13

14 WILLFUL INFRINGEMENT OF THE '028 PATENT

15 244. OptoLum repeats and realleges the allegations contained in paragraphs 1–243
16 above as if fully set forth herein.

17 245. As alleged in paragraphs 237-239 *supra*, Cree infringes the '028 Patent.

18 246. As alleged in paragraph 199, *supra*, the '028 Patent is a child of the '536 Patent,
19 and issued in July, 2007.
20

21 247. Further, as alleged in paragraphs 150–160, *supra*, on April 25, 2012, during
22 prosecution of Cree's patent application that issued into U.S. Patent No. 9,243,758, a USPTO
23 examiner cited the '536 Patent as material to patentability of the pending Cree application.
24

25 248. Then again, on September 13, 2013, during the prosecution of Cree's patent
26 application that issued into U.S. Patent No. 8,789,977, a third party submitted the '536 Patent
27
28

1 for consideration by the examiner, including a detailed discussion of the similarities between
2 the pending Cree application and the '536 Patent.

3 249. Yet again, the '536 Patent was cited in an IDS to the USPTO as relevant to
4 patentability on December 18, 2014, during prosecution of Cree's patent application that issued
5 into U.S. Patent No. 9,030,120, and once more, on April 3, 2015, in connection with the
6 prosecution of a patent application that issued into U.S. Patent No. 9,217,542.
7

8 250. The existence of the '028 Patent as a child of the '536 Patent would have been
9 readily apparent from even a cursory examination of the publicly available information
10 regarding the '536 Patent such as Public Pair and Google Patents.

11 251. Therefore, Cree knew or should have known of the '028 Patent before the date of
12 first infringement and is therefore liable for willfully infringing the '028 Patent.
13

14 252. Cree's infringement of the '028 Patent was willful and deliberate, entitling
15 OptoLum to enhanced damages and attorney's fees.

16 253. Additional allegations regarding Cree's knowledge of the '028 Patent and willful
17 infringement will likely have evidentiary support after a reasonable opportunity for discovery.

18 254. Cree's infringement of the '028 Patent is exceptional and entitles OptoLum to
19 attorney's fees and costs incurred in prosecuting this action under 35 U.S.C. § 285.
20

21 **PRAYERS FOR RELIEF**

22 WHEREFORE, OptoLum respectfully requests that this Court enter judgment against
23 Cree, granting OptoLum the following relief:
24

25 A. finding that Cree has engaged in false advertising in violation of 15 U.S.C. 1125(a);

26 B. finding that Cree has been unjustly enriched in violation of state and federal common
27 law and principles of equity;
28

1 C. enjoining Cree, its officers, directors, agents, servants, affiliates, employees, divisions,
2 branches, subsidiaries and parents and all others acting in concert or privity with it from claiming
3 to have conceived of, discovered, designed, or invented the technology comprising the Filament
4 Tower™, from using the marks “Filament Tower” or “Filament Tower Technology” in its
5 advertising and promotional materials and from advertising said Filament Tower™ as
6 “patented,” pursuant to 15 U.S.C. § 1116;

8 D. ordering Cree to correct any erroneous impression persons may have derived
9 concerning the origins of its Filament Tower™ technology, including, without limitation,
10 corrective advertising and providing written notice to the public;

11 E. awarding OptoLum its damages suffered as the result of Cree’s violation of the
12 Lanham Act in an amount sufficient to compel Cree to disgorge its ill-gotten gains from its false
13 advertising, pursuant to 15 U.S.C. § 1117;

14 F. awarding OptoLum actual damages suffered as the result of Cree’s unjust enrichment,
15 pursuant to principles of equity;

17 G. finding that Cree has infringed the ’303 Patent and the ’028 Patent;

18 H. enjoining Cree, its officers, directors, agents, servants, affiliates, employees, divisions,
19 branches, subsidiaries and parents and all others acting in concert or privity with it, from
20 infringing the ’303 Patent and the ’028 Patent pursuant to 35 U.S.C. § 283;

21 I. awarding OptoLum its damages suffered as a result of Cree’s infringement of the ’303
22 Patent and the ’028 Patent pursuant to 35 U.S.C. § 284;

24 J. awarding OptoLum punitive damages as the result of Cree’s willful and purposeful
25 patent infringement and false advertisement in an amount equal to at least three-times
26
27
28

1 OptoLum’s damages for each such violation, pursuant to 15 U.S.C. §1117, 35 U.S.C. § 284 and
2 principles of equity;

3 L. awarding OptoLum its costs, attorney’s fees, expenses and interest; and

4 M. granting OptoLum such other and further relief as the Court may deem just and
5 proper.
6

7
8 **DEMAND FOR JURY TRIAL**

9 OptoLum hereby demands trial by jury on all issues so triable pursuant to Fed. R. Civ. P.
10 38.

11
12
13
14
15
16
17
18
19
20
21
22
23
24
25
26
27
28

1 Dated: February 2, 2017

Respectfully Submitted,

2 /s/ Robert A. Brooks

3 Robert A. Brooks (*pro hac vice*)

4 Mead Mistic (*pro hac vice*)

5 Leah R. McCoy (*pro hac vice*)

6 Jason C. Williams (*pro hac vice*)

McCARTER & ENGLISH, LLP

265 Franklin St.

7 Boston, MA 02110

Telephone: 617-449-6500

8 Facsimile: 617-607-9200

9 rbrooks@mccarter.com

10 mmistic@mccarter.com

11 lmccoy@mccarter.com

12 jwilliams@mccarter.com

ATTORNEYS FOR PLAINTIFF

OPTOLUM, INC.

1
2
3
4
5
6
7
8
9
10
11
12
13
14
15
16
17
18
19
20
21
22
23
24
25
26
27
28