

IN THE UNITED STATES DISTRICT COURT
FOR THE EASTERN DISTRICT OF TEXAS
MARSHALL DIVISION

DIGITAL STREAM IP, LLC,)	
)	
Plaintiff,)	
)	Civil Action No. 2:17-cv-313
v.)	
)	JURY TRIAL DEMANDED
CBS RADIO INC.,)	
)	
Defendant.)	
_____)	

COMPLAINT

For its Complaint, Plaintiff Digital Stream IP, LLC ("Digital Stream"), by and through the undersigned counsel, alleges as follows:

THE PARTIES

1. Digital Stream is a Texas limited liability company with a place of business located at 1400 Preston Road, Suite 475, Plano, Texas 75093.
2. Defendant CBS Radio Inc. a Delaware company with, upon information and belief, a place of business located at 1271 Avenue of the Americas, New York, New York 10020.
3. Upon information and belief, Defendant has offices in the State of Texas.

JURISDICTION AND VENUE

4. This action arises under the Patent Act, 35 U.S.C. § 1 *et seq.*
5. Subject matter jurisdiction is proper in this Court under 28 U.S.C. §§ 1331 and 1338.
6. Upon information and belief, Defendant conducts substantial business in this forum, directly or through intermediaries, including: (i) at least a portion of the infringements

alleged herein; and (ii) regularly doing or soliciting business, engaging in other persistent courses of conduct and/or deriving substantial revenue from goods and services provided to individuals in this district.

7. Venue is proper in this district pursuant to §§ 1391(b), (c) and 1400(b).

THE PATENT-IN-SUIT

8. On June 29, 2004, U.S. Patent No. 6,757,913 (the "'913 patent), entitled "Wireless Music and Data Transceiver System," was duly and lawfully issued by the U.S. Patent and Trademark Office. A true and correct copy of the '913 patent is attached hereto as Exhibit A.

9. The '913 patent solves problems of providing digital audio and display of corresponding program information associated with a digital music service. It ensures that a listener will continue to enjoy the advantages of digital audio, while also enabling portable reception of the service within a localized setting.

10. The claims of the '913 patent effect an improvement in digital audio transceivers, digital audio players, digital music transmitters and the digital audio technical field to solve the problems of limited range, signal strength, variety of channels, program information available and overall accessibility and ease of use. The '913 patent overcame these difficulties by, for example, utilizing a wireless digital audio transceiver or wireless digital audio player including a user interface to enable a user to select digital audio data or a digital audio program from a plurality of digital audio data or programs, a tuner to tune to a frequency associated with a carrier wave containing the digital audio data or a frequency associated with the digital audio program, a demodulator to extract or demodulate the digital audio data and program information, and a digital to analog converter to convert the digital audio data into an analog signal for playback by the user.

11. Digital Stream is the assignee and owner of the right, title and interest in and to the '913 patent, including the right to assert all causes of action arising under said patent and the right to any remedies for infringement of it.

COUNT I – INFRINGEMENT OF U.S. PATENT NO. 6,757,913

12. Digital Stream repeats and realleges the allegations of paragraphs 1 through 11 as if fully set forth herein.

13. Without license or authorization and in violation of 35 U.S.C. § 271(a), Defendant is liable for infringement of at least claim 31 of the '913 patent by making, using, importing, offering for sale, and/or selling a digital audio transmitter, including, but not limited to, the digital audio transmitter for broadcasting CBS Radio stations.

14. More specifically and upon information and belief, Defendant uses a digital music transmitter to enable broadcast of its programming. *See* <http://cbsradio.com/press/cbs-sports-radios-popular-programs-tiki-and-tierney-and-the-da-show-move-to-new-times-as-part-of-multi-year-contract-renewals/> (last accessed Apr. 13, 2017); *see also* http://licensing.fcc.gov/cgi-bin/ws.exe/prod/cdbs/pubacc/prod/sta_det.pl?Facility_id=59820 (last accessed Apr. 13, 2017); <https://www.fcc.gov/media/radio/digital-radio> (last accessed Apr. 13, 2017). Defendant uses a transmitter input to receive a plurality of digital audio data streams for bundling together into a multi-cast transmission to be broadcast simultaneously over a single radio station frequency allocation. *See* <https://hdradio.com/broadcasters/engineering-support/high-quality-consistent-multicast-engineering> (last accessed Apr. 13, 2017); <https://hdradio.com/broadcasters/overview/how-it-works> (last accessed Apr. 13, 2017).



<https://hdradio.com/stations> (last accessed Apr. 13, 2017). Defendant uses a demodulator for demodulating each of the digital audio data streams. *See* National Radio Systems Committee, NRSC-5-C In-band/on-channel Digital Radio Broadcasting Standard September, 2011 ("NRSC-5-C") at pp. 15, 36 (available at <http://nrcstandards.org/SG/NRSC-5-C.pdf> (last accessed Apr. 13, 2017)); National Radio Systems Committee, NRSC-R207 Broadcasting Surround Sound Audio Over IBOC Digital Radio – Issues and Resources for FM Broadcasters January 10, 2007 at p. 19 (available at <http://www.nrcstandards.org/Reports/NRSC-R207.pdf> (last accessed Apr. 13, 2017)). Defendant uses a carrier signal generator generating a plurality of groups of carrier signals each carrier signal on a distinct frequency, for example, in order to carry digital signals on upper and lower sidebands of the frequency range. *See* NRSC-5-C at pp. 31-32.

The IBOC FM hybrid mode places low-level digital carriers in the upper and lower sidebands of the analog spectrum as shown in Figure 1. These carriers are modulated with redundant information to convey the digital audio and data.

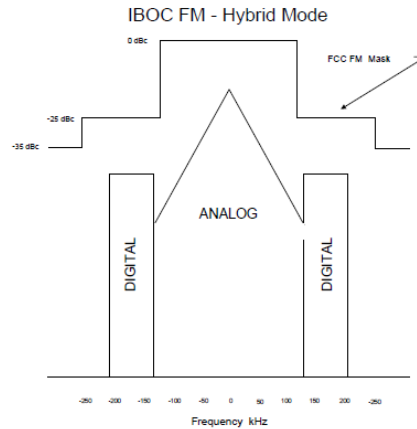

Figure 1 FM IBOC Hybrid waveform

Jeff R. Detweiler, Conversion Requirements for AM & FM IBOC Transmission ("Detweiler") at p. 1 (available at https://hdradio.com/sites/default/files/conversion_requirements.pdf (last accessed Apr. 13, 2017)). Defendant uses a modulator for modulating each digital audio data stream on a carrier signal from each of the groups of carrier signals to enable capture of any one of the plurality of digital audio streams by tuning to a frequency of a carrier wave containing a desired digital audio stream. *See* NRSC-5-C at pp. 11, 15-16; *see also* Detweiler at p. 1. Defendant uses a combiner for combining each of the carrier signals into a combined signal and outputting the combined signal to an antenna. *See* NRSC-5-C at pp. 23-24.

FM TRANSMITTERS

Three methods exist for producing the IBOC hybrid FM signal. Initial station conversions will likely utilize what is known as “high-level combining” or “separate amplification” shown in Figure 7. With this method, the existing station transmitter will have its output combined with the output of a separate digital transmitter compatible with IBOC technology. The resulting hybrid signal will then be fed to the existing station antenna.

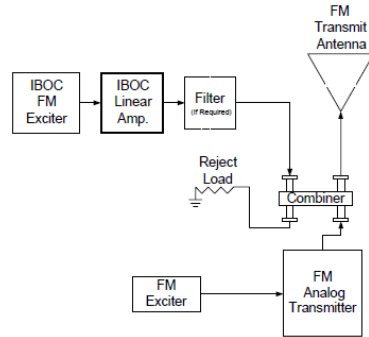
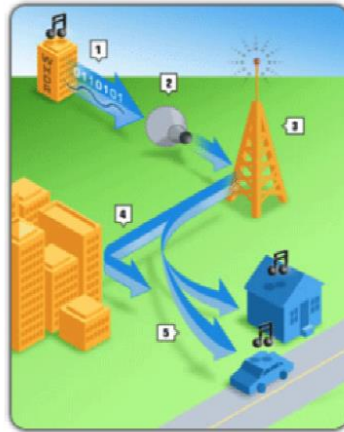

Figure 7 FM IBOC high-level, separate amplification

Detweiler at p. 5.

HOW IT WORKS

1. Stations bundle analog and digital audio signals (with textual data, such as artist and song information, weather and traffic, and more).
2. The digital signal layer is compressed using iBiquity's HDC compression technology.
3. The combined analog and digital signals are transmitted.
4. The most common form of interference, multipath distortion, occurs when part of a signal bounces off an object and arrives at the receiver at a different time than the main signal. HD Radio receivers are designed to sort through the reflected signals and reduce static, hiss, pops and fades.
5. The signal will be compatible with HD Radio receivers and analog radios



<https://hdradio.com/broadcasters/overview/how-it-works> (last accessed Apr. 13, 2017).

15. Digital Stream is entitled to recover from Defendant the damages sustained by Digital Stream as a result of Defendant's infringement of the '913 patent in an amount subject to proof at trial, which, by law, cannot be less than a reasonable royalty, together with interest and costs as fixed by this Court under 35 U.S.C. § 284

JURY DEMAND

Digital Stream hereby demands a trial by jury on all issues so triable.

PRAYER FOR RELIEF

WHEREFORE, Digital Stream requests that this Court enter judgment against Defendant as follows:

- A. An adjudication that Defendant has infringed the '913 patent;
- B. An award of damages to be paid by Defendant adequate to compensate Digital Stream for Defendant's past infringement of the '913 patents and any continuing or future infringement through the date such judgment is entered, including interest, costs, expenses and an accounting of all infringing acts including, but not limited to, those acts not presented at trial;
- C. A declaration that this case is exceptional under 35 U.S.C. § 285, and an award of Digital Stream's reasonable attorneys' fees; and
- D. An award to Digital Stream of such further relief at law or in equity as the Court deems just and proper.

Dated: April 14, 2017

/s/ Richard C. Weinblatt
Stamatios Stamoulis DE SB #4606
Richard C. Weinblatt DE SB #5080 – Lead Counsel
Stamoulis & Weinblatt LLC
Two Fox Point Centre
6 Denny Road, Suite 307
Wilmington, DE 19809
Telephone: (302) 999-1540
Facsimile: (302) 762-1688
stamoulis@swdelaw.com
weinblatt@swdelaw.com

/s/ L. Charles van Cleef

L. Charles van Cleef TX SB #00786305

Van Cleef Law Office

PO Box 2432

Longview, TX 75606-2432

Telephone: (903) 248-8244

Facsimile: (903) 248-8249

charles@vancleef.pro

Attorneys for Plaintiff

Digital Stream IP, LLC