

1 John E. Lord (CA SBN 216111)
Email: jlord@onellp.com
2 ONE LLP
3 9301 Wilshire Blvd, Penthouse Suite
4 Beverly Hills, CA 90210
5 Telephone: (310) 866-5157
6 Facsimile: (310) 943-2085

7 Joseph K. Liu (CA SBN 216227)
Email: jliu@onellp.com
8 Christopher W. Arledge (CA SBN 200767)
Email: carledge@onellp.com
9 ONE LLP
4000 MacArthur Blvd
10 East Tower, Suite 500
11 Newport Beach, CA 92660
Telephone: (949) 502-2870
Facsimile: (949) 258-5081

12 *Counsel for Plaintiff Interface Linx, LLC*

13 UNITED STATES DISTRICT COURT
14 CENTRAL DISTRICT OF CALIFORNIA
15 WESTERN DIVISION
16

17 INTERFACE LINX, LLC, a
18 California limited liability company,
19 Plaintiff,

20 v.

21 HAIER AMERICA COMPANY,
22 LLC, a Delaware limited liability
23 corporation and HAIER GROUP
CORPORATION, a foreign
corporation,

24 Defendants.

Case No. 2:17-cv-03170

**COMPLAINT FOR PATENT
INFRINGEMENT**

25
26
27
28

1 For its Complaint against Haier America Company, LLC (“Haier”) and
2 Haier Group Corporation (“HGC”) (collectively “Defendants”), Plaintiff Interface
3 Linx, LLC (“Interface” or “Plaintiff”) alleges as follows:

4 **THE PARTIES**

5 1. Plaintiff Interface Linx, LLC (“Interface”) is a California limited
6 liability company having a principal place of business at 35 Hugus Alley, Suite 210,
7 Pasadena, CA 91103.

8 2. On information and belief, Haier America Company, LLC (“Haier”) is
9 a limited liability company organized under the laws of Delaware and has its
10 principal place of business at 1800 Valley Road, Wayne, NJ 07470 and has
11 appointed Corporation Service Company, 2711 Centerville Rd Suite 400,
12 Wilmington, DE 19808, as its agent for service of process.

13 3. Haier Group Corporation (“HGC”) is organized under the laws of the
14 People’s Republic of China and has its principal place of business at 1 Haier Rd.,
15 Hi-Tech Zone, Qingdao, Shandong 266101, People’s Republic of China.

16 **JURISDICTION AND VENUE**

17 4. This is a civil action for patent infringement arising under the Patent
18 Act of the United States, 35 U.S.C. §§ 1 *et seq.* This court has subject matter
19 jurisdiction of such federal question claims pursuant to 28 U.S.C. §§ 1331 and
20 1338(a).

21 5. This Court has personal jurisdiction over Defendants in this action
22 because Defendants have committed acts within this district giving rise to this action
23 and has established minimum contacts with this forum such that the exercise of
24 jurisdiction would not offend traditional notions of fair play and substantial justice.
25 Defendants, directly and indirectly, have committed and continue to commit acts of
26 infringement in this district by, among other things, offering to sell and selling
27 products and/or services that infringe the asserted patent.

28 6. Venue is proper under 28 U.S.C. §§ 1391(b), 1391(c) and 1400(b) in

1 that the acts and transactions complained of herein were conceived, carried out,
2 made effective, and had effect within the State of California and within this district,
3 among other places. Defendants reside in this district by virtue of their business
4 activities in this district and having committed acts of direct and indirect
5 infringement in this district.

6 **INTERFACE’S PATENT-IN-SUIT**

7 7. On January 21, 2003, the United States Patent & Trademark Office
8 duly and legally issued United States Letters Patent No. 6,508,678 (“the ’678
9 Patent”), entitled “Electrical Connector Assembly.”

10 8. The ’678 Patent is owned by Interface.

11 **FIRST CLAIM FOR RELIEF**
12 **AGAINST DEFENDANTS FOR DIRECT, INDUCING, AND**
13 **CONTRIBUTORY INFRINGEMENT**

14 Plaintiff incorporates herein by reference the allegations set forth in
15 paragraphs 1-8 of the Complaint as though fully set forth herein.

16 9. A true and correct copy of the ’678 Patent is attached as Exhibit A and
17 incorporated herein by reference.

18 10. Defendants have been and now are infringing at least claim 1 of the
19 ’678 Patent in this district, and elsewhere in the United States by, among other
20 things; making, using, importing, offering for sale, and/or selling products that
21 infringe the ’678 Patent.

22 11. Defendants make, use and sell, within the United States, a plurality of
23 electrical connector assemblies which are integrated into a diverse class of electronic
24 products that infringe the ’678 Patent (collectively referred to hereinafter as
25 “Accused Systems”), and which are designed to the specifications of HDMI Type A.

26 12. The electrical connector assembly of claim 1 offers significant
27 improvements in plug and receptacle design, which greatly improve ease of
28 connectivity and the potential for data transfer once the connection is made. The

1 physical design, envisioned with great specificity by the '678 Patent, offered such
2 improvements over the prior art that the HDMI standards utilized this design to
3 create the Type A plug and receptacle found on the vast majority of electronic
4 devices today.

5 13. Defendants make and sell products that utilize the electrical connector
6 assembly of the '678 Patent. These Accused Systems include, for example and
7 without limitation, Defendants' televisions, such as the 50" Class LED HDTV
8 50E3500.

9 14. Defendants' Accused Systems are designed with the first element of
10 claim 1. Specifically, Defendants' Accused Systems require both plugs and
11 receptacles to form the electrical connector assembly and transfer data, including
12 audio and video, over the HDMI connection. This plug must include plug housing
13 with the mating portion within, the mating portion defined by a multi-sided
14 confining wall. An example of this plug can be found at Defendants' website
15 <http://www.haier.com/pk/products/tv/led-tv/le32b9000.shtml>, as shown below:



22 15. Defendants' Accused Systems are further designed with the second
23 element of claim 2. Specifically, Defendants' Accused Systems require both plugs
24 and receptacles to form the electrical connector assembly and transfer data,
25 including audio and video, over the HDMI connection. This receptacle must include
26 a mating portion with terminals mounted inside within, the mating portion defined
27 by a multi-sided confining wall. An example of this receptacle can be found at
28 Defendants' website <http://www.haieramerica.com/product/50e3500>, as shown

1 below:

2 **Range of Inputs**

3 Includes multiple A/V inputs, including three HDMI
4 and one USB port

5 Hdmi Inputs

3



11

12 16. Defendants' Accused Systems are further designed with the third
13 element of claim 1. HDMI Type A plugs and receptacles, like those used by
14 Defendants in their Accused Systems, are designed with a plurality of confining
15 walls that are specifically designed and oriented. In order for a plug and receptacle
16 to be used together, their confining walls must utilize the same shape, with the plug
17 being sized smaller in order to fit within the receptacle.

18 17. In HDMI Type A connectors, like those designed into Defendants'
19 Accused Systems, the first and second sides are found opposite of each other and the
20 first side is longer than the second side. A pair of third sides are then connected to
21 the opposite ends of the first side, each of the pair being shorter than either the first
22 or second side. A pair of fourth sides are then connected to the opposite ends of the
23 second side, but the width between the two fourth sides must be less than that
24 between the two third sides. Finally, a pair of fifth sides are then connected between
25 to connect the third and fourth side of their respective sides, the fifth sides must be
26 angled away from each other while extending from the fourth sides to the third sides
27 that they connect to. This is illustrated by the following diagram, which has been
28 color coded to follow the claim language and has had each of the sides of the

1 receptacle labeled in accordance with the claim language.

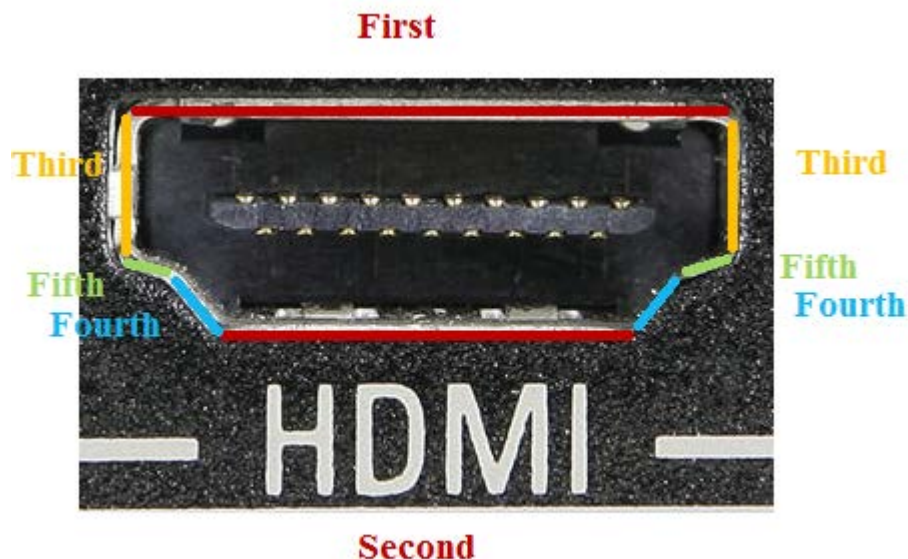

12
13 18. Defendants' Accused Systems are further designed with the fourth
14 element of claim 1. As shown in the figure above, in HDMI Type A connectors, like
15 those designed into Defendants' Accused Systems, the first and second sides run
16 substantially parallel to each other. Further, the third sides are substantially
17 perpendicular to the first side.

18 19. Defendants' Accused Systems are further designed with the final
19 element of claim 1. As shown in the figure above, in HDMI Type A connectors, like
20 those designed into Defendants' Accused Systems, the fourth sides extend obliquely
21 from each end of the second side.

22 20. The '678 Patent has been cited by over 50 issued patents and
23 published patent applications as relevant prior art.

24 21. By making, using, selling, and offering for sale such devices, and all
25 like products that are covered by one or more claims of the '678 Patent, including at
26 least claim 1, Defendants have infringed and continue to infringe the '678 Patent,
27 including infringement under 35 U.S.C. § 271.

28 22. On information and belief, Defendants have also indirectly infringed

1 and continue to indirectly infringe the '678 Patent by actively inducing direct
2 infringement by other persons, such as their customers and end users, who operate
3 systems that embody or otherwise practice one or more of the claims of the '678
4 Patent, when Defendants had knowledge (or willful blindness thereto) of the '678
5 Patent and that the activities they were inducing would result in direct infringement
6 by others and intended that their actions would induce direct infringement by others.
7 Defendants intended and were aware that the normal and customary use of the
8 Accused Systems would infringe the '678 Patent.

9 23. Defendants intended to induce other persons, such as their customers
10 and end users, to directly infringe the '678 Patent by (1) advising or directing them
11 to make, use, sell, or import the Accused Systems, (2) advertising and promoting the
12 use of the Accused Systems, and (3) distributing instructions for using the Accused
13 Systems, all in an infringing manner. On information and belief, Defendants
14 engaged in such inducement to promote the sales of the Accused Systems, e.g.,
15 through user manuals, product support, and marketing materials to actively induce
16 the users of the accused products to infringe the '678 Patent.

17 24. On information and belief, Defendants have and continue to
18 contribute to infringement other persons, such as their customers and end users, to
19 directly infringe at least claim 1 of the '678 Patent. Defendants contribute to
20 infringement by offering to sell, selling within the United States, or importing into
21 the United States materials and apparatus for use with in practicing at least claim 1
22 of the '678 Patent. Specifically, on information and belief, Defendants know that
23 their products with a HDMI receptacle, for example, and materials and apparatus
24 designed for use with this receptacle, constitute a material and component part of the
25 invention of the '678 Patent, and is infringing, and that it is not a staple article or
26 commodity of commerce suitable for substantial non-infringing use, and it has no
27 use apart from infringing the '678 Patent.

28 25. On information and belief, Defendants have had knowledge of the

1 '678 Patent since at least the filing of this Complaint.

2 26. On information and belief, Defendants will continue to infringe the
3 '678 Patent unless enjoined by this Court.

4 27. As a direct and proximate result of Defendants' infringement of the
5 '678 Patent, Interface has been and continues to be, damaged in an amount yet to be
6 determined, but in no event less than a reasonable royalty for the use made of the
7 invention by Defendants, together with interest and costs as fixed by the Court.

8 28. Unless a preliminary and permanent injunction are issued enjoining
9 Defendants and their officers, agents, servants and employees, and all others acting
10 on their behalf or in concert with Defendants, from infringing the '678 Patent,
11 Interface, will be greatly and irreparably harmed.

12 **PRAYER FOR RELIEF**

13 WHEREFORE, Interface prays for judgment against Defendants as follows:

14 (1) For a judicial decree that Defendants have infringed, and
15 continue to infringe, the '678 Patent;

16 (2) For a judicial decree that Defendants, their respective
17 subsidiaries, officers, agents, servants, employees, licensees, and all other persons or
18 entities acting or attempting to act in active concert or participation with it or acting
19 on their behalf, be preliminarily and permanently enjoined from further infringement
20 of the '678 Patent;

21 (3) For a judicial decree that order Defendants to account for and
22 pay to Interface all damages caused to Interface by reason of Defendants'
23 infringement pursuant to 35 U.S.C. Section 284, including enhanced damages;

24 (4) For a judicial decree finding that this is an exceptional case
25 within the meaning of 35 U.S.C. § 285 and awarding to Plaintiff its reasonable
26 attorneys' fees;

27 (5) For a judicial decree that Defendants pay an ongoing royalty in
28 an amount to be determined for continued infringement after the date of judgment;

1 (6) For a judicial decree awarding to Interface pre-judgment and
2 post-judgment interest on the damages caused to it by Defendants' infringement; and

3 (7) For any such other and further relief as the Court may deem just
4 and proper under the circumstances.

5

6 Dated: April 27, 2017

ONE LLP

7

By: /s/John E. Lord

8

John E. Lord

9

Attorneys for Plaintiff,

10

Interface Linx, LLC

11

12

13

14

15

16

17

18

19

20

21

22

23

24

25

26

27

28

1
2
3
4
5
6
7
8
9
10
11
12
13
14
15
16
17
18
19
20
21
22
23
24
25
26
27
28

DEMAND FOR JURY TRIAL

Plaintiff Interface hereby demands trial by jury in this action.

Dated: April 27, 2017

ONE LLP

By: /s/John E. Lord

John E. Lord
Attorneys for Plaintiff,
Interface Linx, LLC

EXHIBIT A



US006508678B1

(12) **United States Patent**
Yang

(10) **Patent No.:** **US 6,508,678 B1**
(45) **Date of Patent:** **Jan. 21, 2003**

- (54) **ELECTRICAL CONNECTOR ASSEMBLY**
- (75) Inventor: **Sheng-Ho Yang**, Taipei Hsien (TW)
- (73) Assignee: **Advanced Connecteck Inc.**, Taipei Hsien (TW)
- (*) Notice: Subject to any disclaimer, the term of this patent is extended or adjusted under 35 U.S.C. 154(b) by 64 days.

6,261,129 B1	*	7/2001	Kusagaya	439/677
6,280,209 B1	*	8/2001	Bassler et al.	439/101
6,322,395 B1	*	11/2001	Nishio et al.	439/607
6,386,918 B1	*	5/2002	Zheng et al.	439/607

FOREIGN PATENT DOCUMENTS

GB		1029090	*	5/1966	439/677
----	--	---------	---	--------	-------	---------

* cited by examiner

Primary Examiner—Tulsidas Patel

Assistant Examiner—Thanh-Tam Le

(74) *Attorney, Agent, or Firm*—Merchant & Gould P.C.

- (21) Appl. No.: **09/653,129**
- (22) Filed: **Aug. 31, 2000**

(57) **ABSTRACT**

- (51) **Int. Cl.**⁷ **H01R 13/64**
- (52) **U.S. Cl.** **439/677; 439/607**
- (58) **Field of Search** 439/607, 610, 439/676, 677, 680, 682, 101, 108, 924.1

An electrical connector assembly includes a plug having a first mating portion defined by a multi-sided first confining wall, and a receptacle having a second mating portion defined by a multi-sided second confining wall. Each of the first and second confining walls has opposite first and second sides, a pair of opposite third sides respectively connected to two opposite ends of the first side, a pair of fourth sides respectively connected to two opposite ends of the second sides, and a pair of fifth sides each extending between and interconnecting one of the third sides and one of the fourth sides. The first side is longer than the second side. The width between the third sides is greater than that between the fourth sides. The fifth sides are angled away from each other while extending from the fourth sides to the third sides.

(56) **References Cited**

U.S. PATENT DOCUMENTS

3,710,197 A	*	1/1973	Olds et al.	317/118
5,046,960 A	*	9/1991	Fedder	439/108
5,051,099 A	*	9/1991	Pickles et al.	439/108
5,634,819 A	*	6/1997	Pan et al.	439/637
5,647,765 A	*	7/1997	Haas et al.	439/609
5,651,685 A	*	7/1997	Brinkman et al.	439/79
6,041,498 A	*	3/2000	Hillbish et al.	29/883
6,171,125 B1	*	1/2001	Kirkendall	439/218

5 Claims, 9 Drawing Sheets

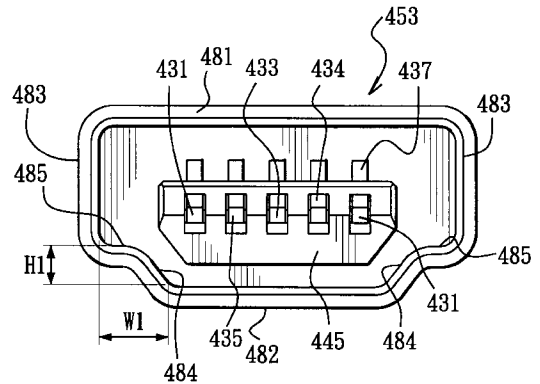
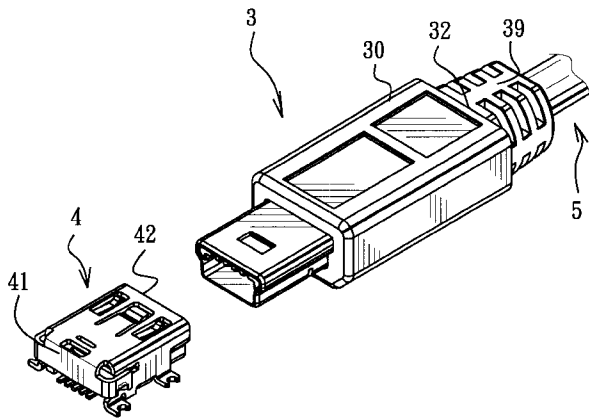

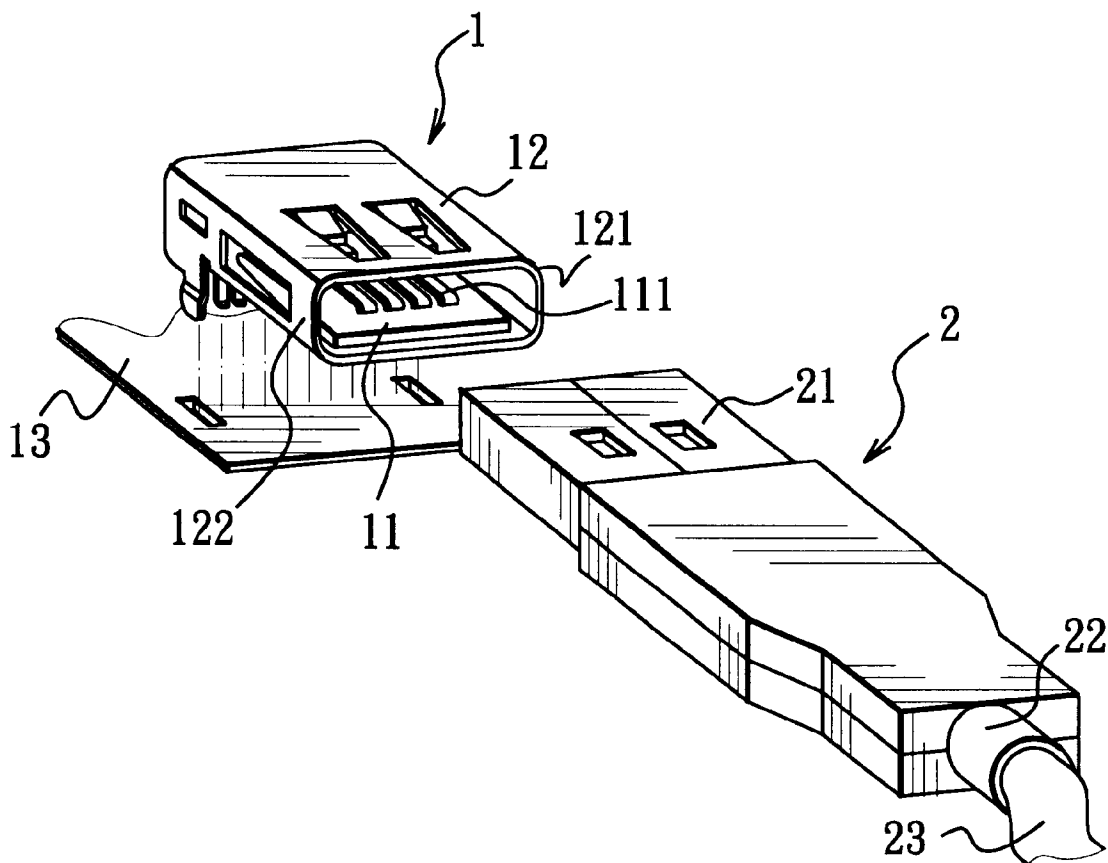

FIG. 1
PRIOR ART

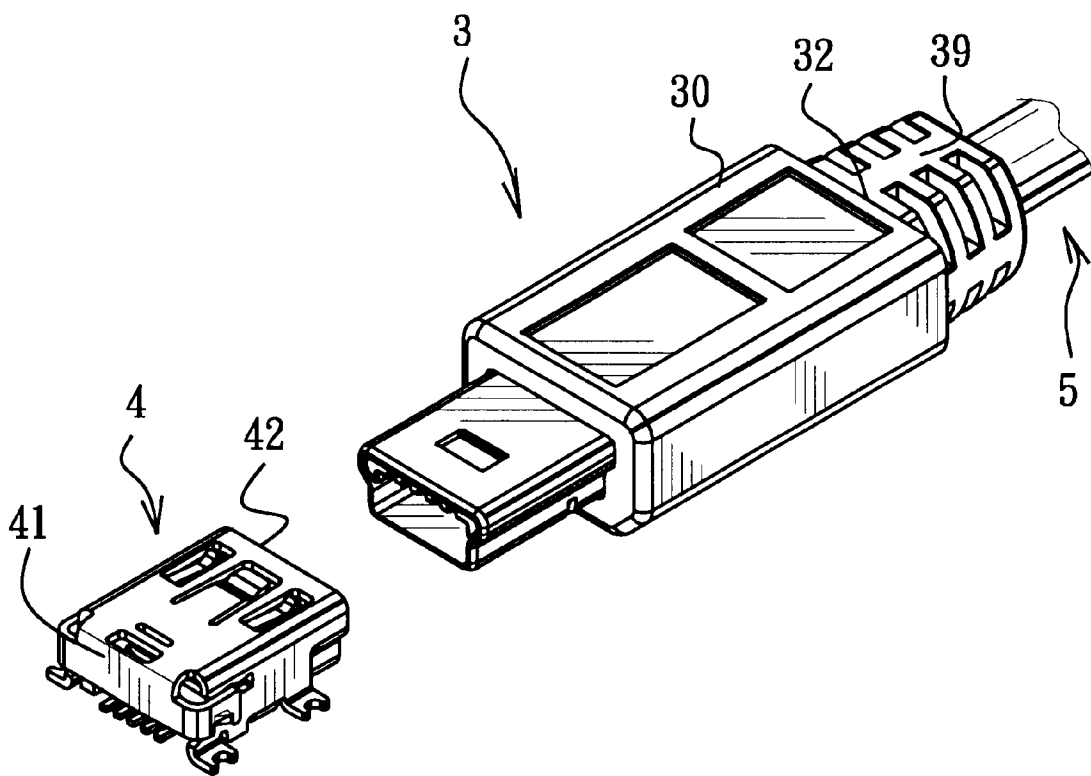

FIG. 2

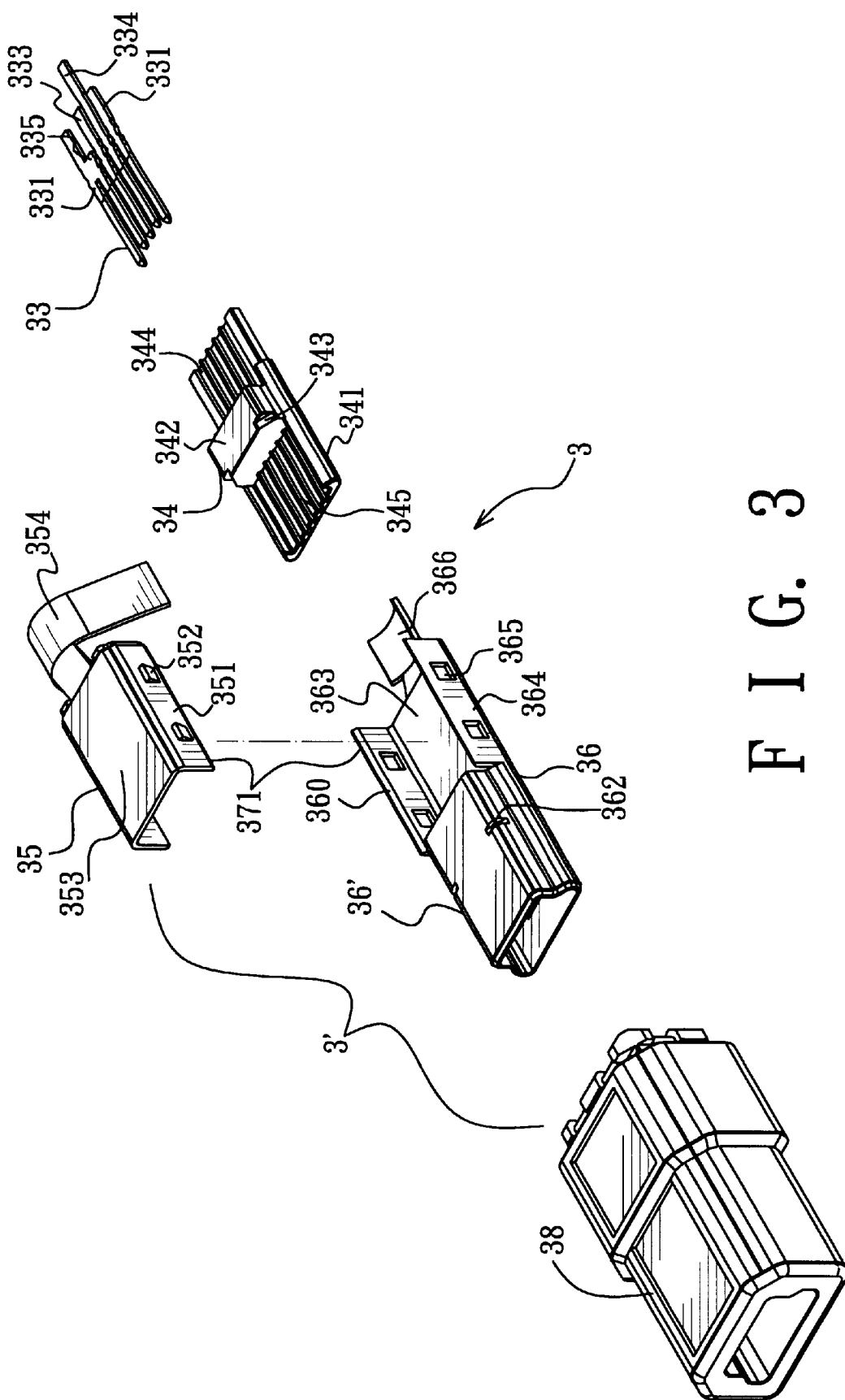

FIG. 3

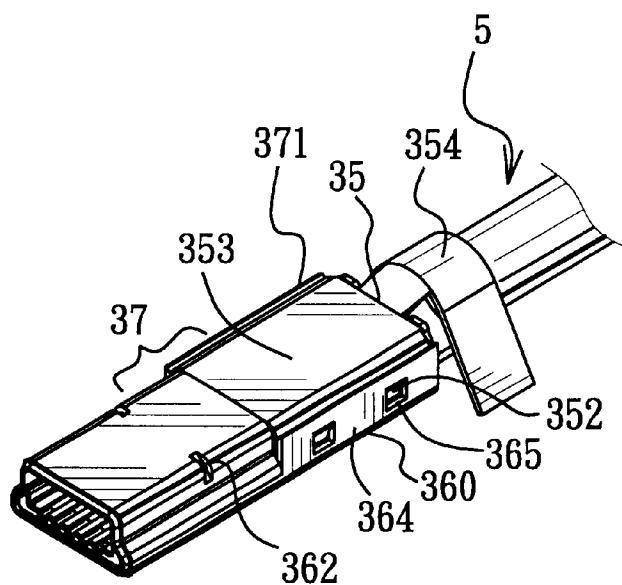

FIG. 4

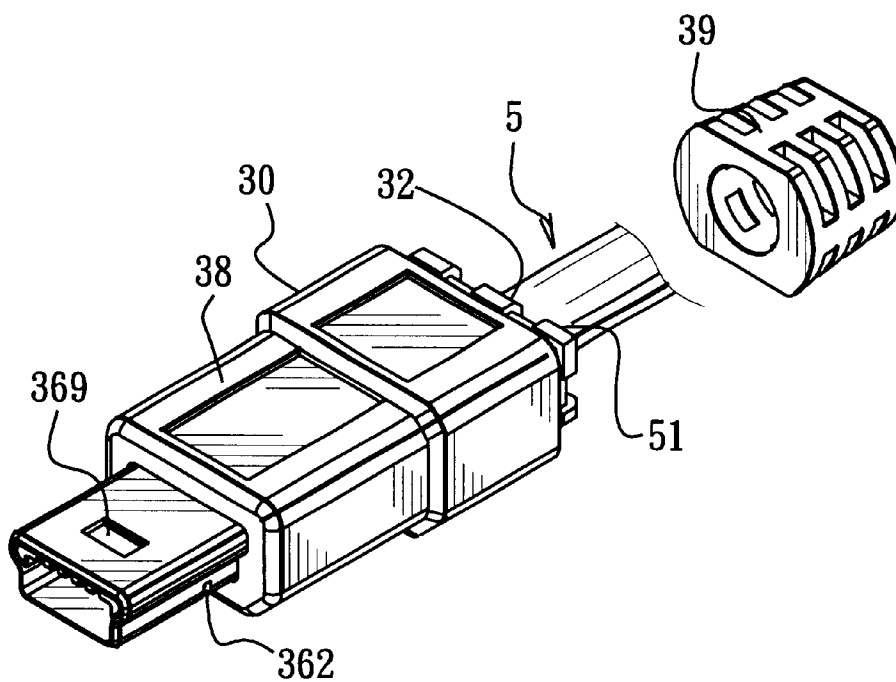
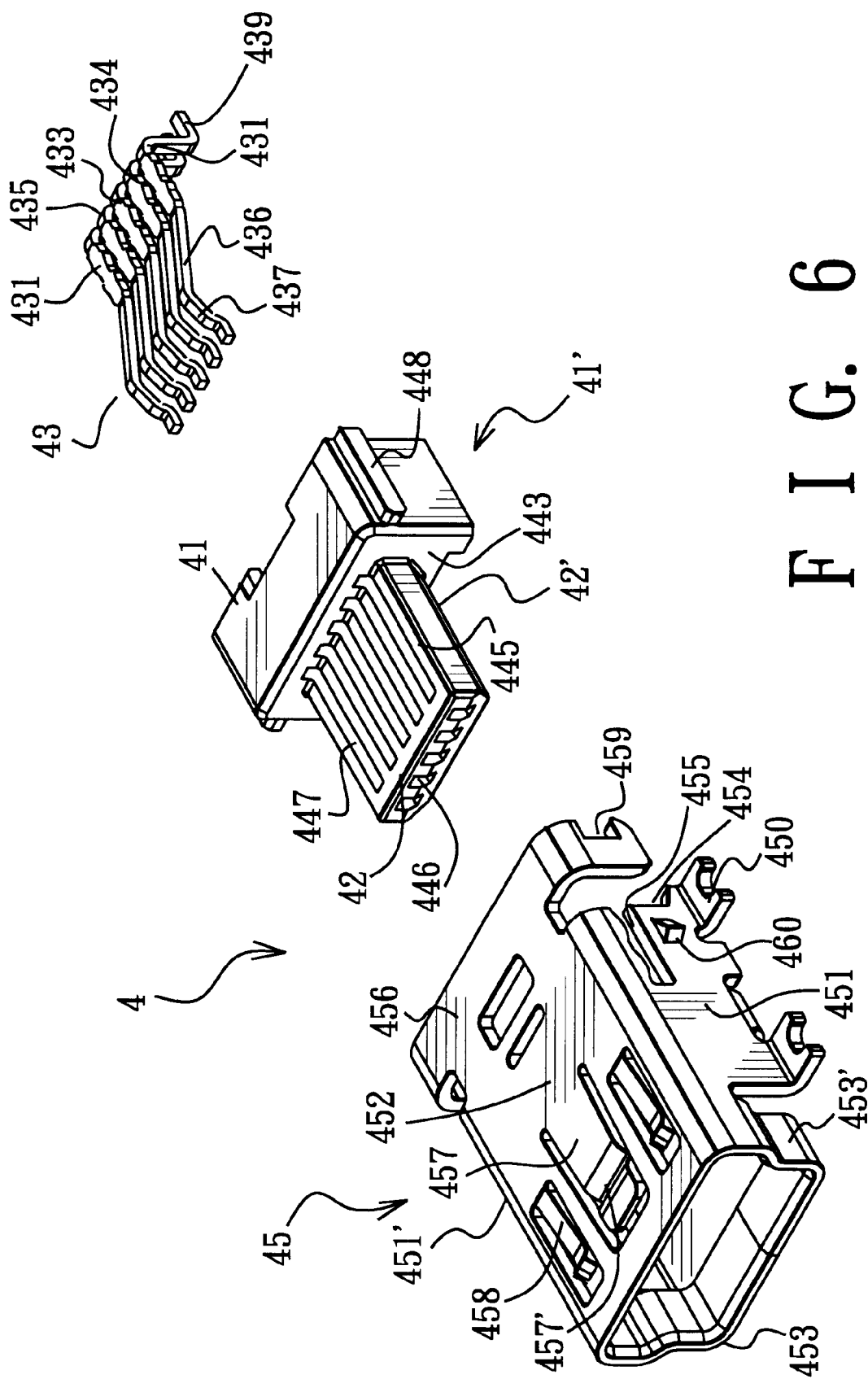

FIG. 5



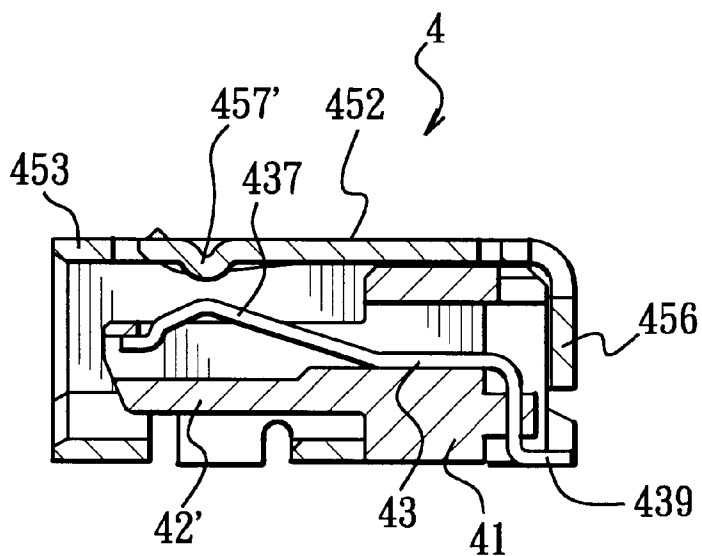

FIG. 7

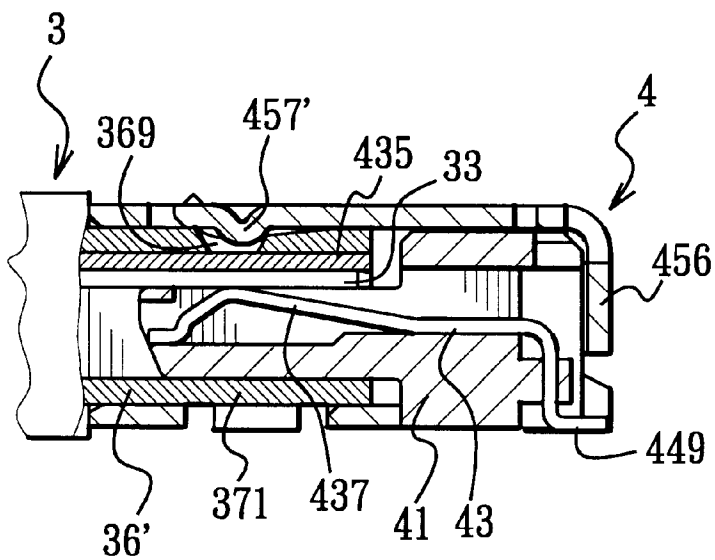
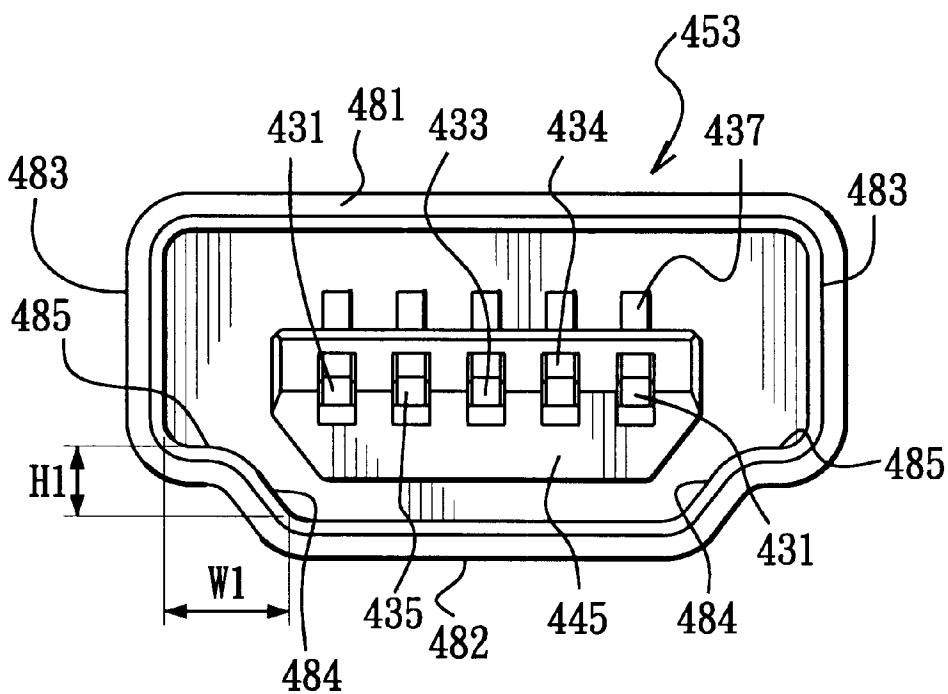
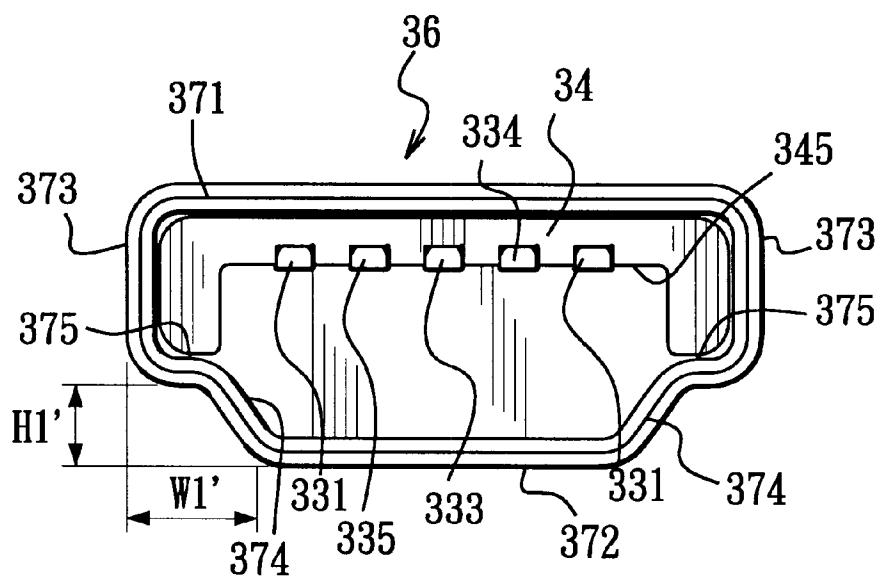

FIG. 8



F I G. 9



F I G. 10

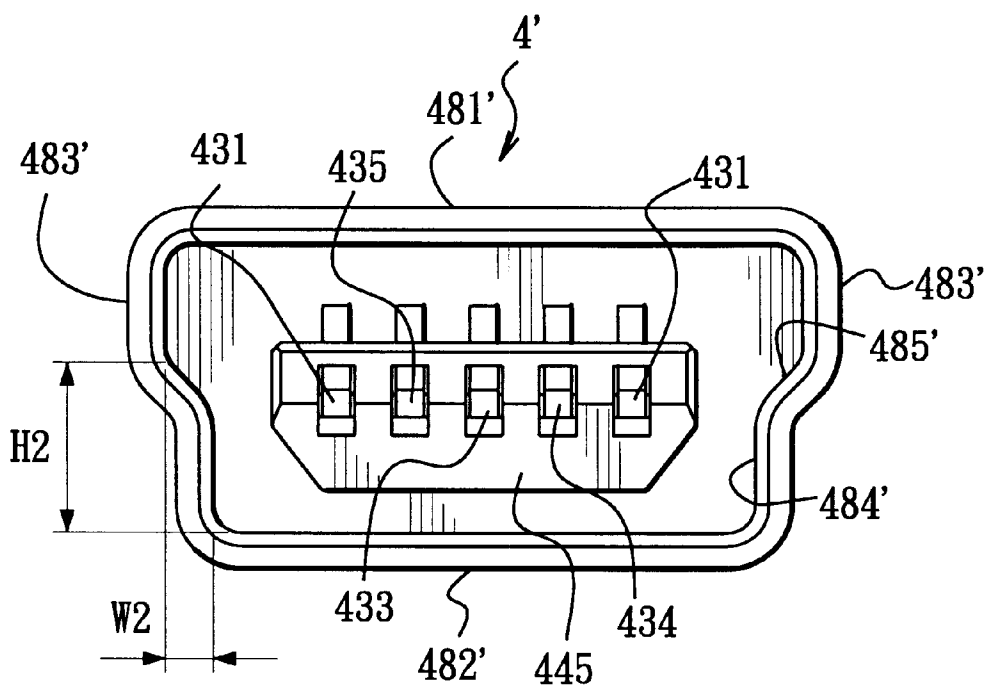

F I G. 11

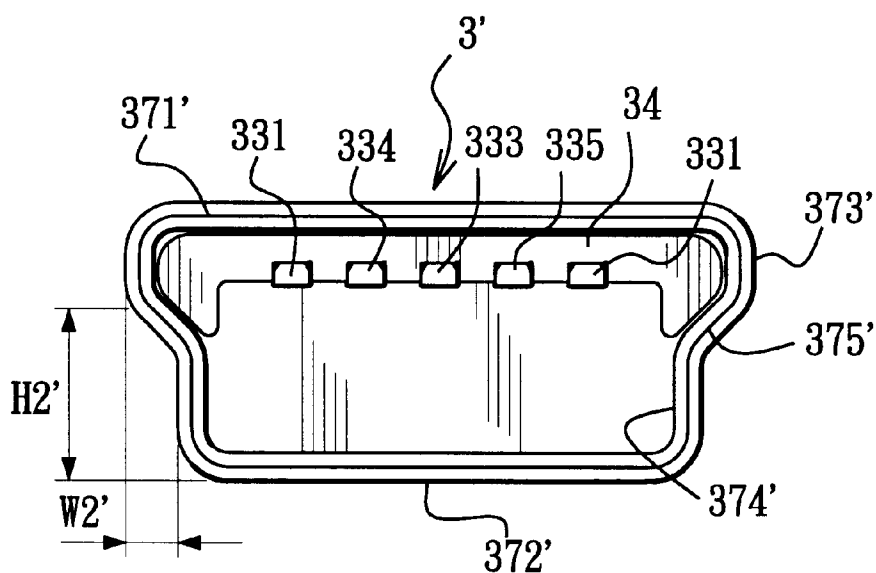

F I G. 12

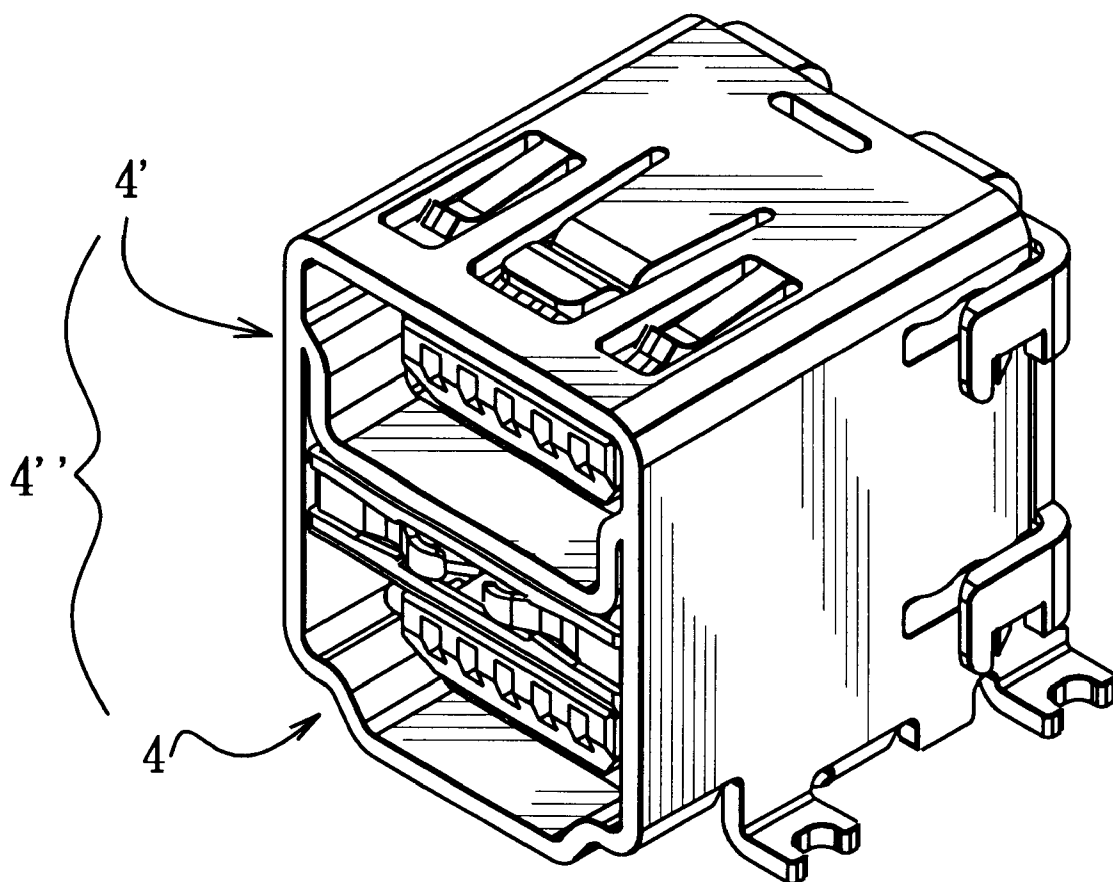

F I G. 13

US 6,508,678 B1

1

ELECTRICAL CONNECTOR ASSEMBLY**BACKGROUND OF THE INVENTION**

1. Field of the Invention

This invention relates to an electrical connector assembly, more particularly to a USB type electrical connector assembly.

2. Description of the Related Art

FIG. 1 illustrates a conventional USB (Universal Serial Bus Connector) electrical connector assembly that serves as a medium for data transmission in a computer. The assembly includes a receptacle 1 with a complementary plug 2. The receptacle 1 includes a receptacle housing 12 having a receptacle mating portion 122 formed with a substantially rectangular opening 121 for receiving the plug 2, a receptacle terminal seat 11 disposed in the receptacle housing 12, and a plurality of receptacle terminals 111 mounted on the receptacle terminal seat 11 and having ends adapted to be-connected to a printed circuit board 13. The plug 2 includes a plug housing and a plurality of plug terminals (not shown) mounted in the plug housing. The plug housing has a plug mating portion 21 adapted to mate with the receptacle mating portion 122 and having a cable connecting end 22 adapted to be connected to a cable 23.

The cable 23 normally has two opposite ends provided with the same plugs 2 that respectively serve as data input and output connectors. As such, there is a tendency to plug a wrong one of the plugs 2 into the receptacle 1 of a printed circuit board when using the cable 23 to connect an electrical device to the printed circuit board, thereby hindering data transmission between the electrical device and the printed circuit board.

SUMMARY OF THE INVENTION

Therefore, the object of the present invention is to provide an electrical connector assembly that is capable of overcoming the aforementioned drawback.

According to the present invention, an electrical connector assembly comprises a plug that includes a plug housing having a first mating portion, and a plurality of plug terminals mounted inside the plug housing, the first mating portion being defined by a multi-sided first confining wall; and a receptacle that includes a receptacle housing having a second mating portion to mate with the first mating portion, and a plurality of receptacle terminals mounted inside the receptacle housing, the second mating portion being defined by a multi-sided second confining wall, each of the first and second confining walls having opposite first and second sides, a pair of opposite third sides respectively connected to two opposite ends of the first side, a pair of fourth sides respectively connected to two opposite ends of the second sides, and a pair of fifth sides each extending between and interconnecting one of the third sides and one of the fourth sides, the first side being longer than the second side, the width between the third sides being greater than that between the fourth sides, the fifth sides being angled away from each other while extending from the fourth sides to the third sides.

BRIEF DESCRIPTION OF THE DRAWINGS

In drawings which illustrate embodiments of the invention,

FIG. 1 is an exploded perspective view of a conventional electrical connector assembly adapted to be connected to a printed circuit board;

2

FIG. 2 is an exploded perspective view of an electrical connector assembly embodying this invention;

FIG. 3 is an exploded perspective view of a plug of the electrical connector assembly of FIG. 2;

FIG. 4 is a fragmentary perspective view of the plug of FIG. 3;

FIG. 5 is a partly exploded perspective view of the plug of FIG. 3;

FIG. 6 is an exploded perspective view of a receptacle of the electrical connector assembly of FIG. 2;

FIG. 7 is a cross-sectional side view of a mating portion of the receptacle of FIG. 6;

FIG. 8 is a cross-sectional side view to illustrate mating of the receptacle of FIG. 6 and the plug of FIG. 3;

FIG. 9 is a front view of the receptacle of FIG. 6;

FIG. 10 is a front view of the plug of FIG. 3;

FIG. 11 is a front view to illustrate a modified receptacle of FIG. 6;

FIG. 12 is a front view to illustrate a modified plug of FIG. 3; and

FIG. 13 is a perspective view to illustrate another modified receptacle of FIG. 6.

DETAILED DESCRIPTION OF THE PREFERRED EMBODIMENTS

FIG. 2 illustrates an electrical connector assembly embodying this invention. The electrical connector assembly includes a receptacle 4 with a complementary plug 3.

Referring now to FIGS. 3 to 5, in combination with FIG. 3, the plug 3 includes a plug housing 30 adapted to be connected to a cable 5 at a rear end 32 thereof and having an insulative outer shell 38 and a metal inner shell 37 extending into the outer shell 38, and a plurality of plug terminals 33 mounted in the plug housing 30. The inner shell 37 includes a substantially rectangular supporting portion 371 disposed in the outer shell 38, and a hollow first mating portion 36 defined by a multi-sided first confining wall 36' and projecting from the supporting portion 371 and out of a front end of the outer shell 38. The supporting portion 371 includes a U-shaped base piece 360 having a flat bight portion 363 and two opposite arms 364 which project from two opposite sides of the bight portion 363 in directions substantially perpendicular to the bight portion 363 and which are formed with through-holes 365, and an inverted U-shaped cover piece 35 coupled with the base piece 360 and having a flat bight portion 353 parallel to the bight portion 363 of the base piece 360 and two opposite arms 351 which project from two opposite sides of the bight portion 353 toward the arms 364 of the base piece 360 and which are formed with tongues 352 that respectively and detachably engage the through-holes 365 when the base piece 360 and the cover piece 35 are coupled together. An arc-shaped plate 366 projects from a rear end of the bight portion 363 to support the cable 5. A positioning tape 354 is secured to a rear end of the cover piece 35 adjacent to the arc-shaped plate 366 for winding on the cable 5 and the arc-shaped plate 366 so as to firmly fix the cable 5 on the arc-shaped plate 366. A pair of opposite positioning tongues 362 project inwardly from the first confining wall 36'. A locking opening 369 is formed in the first confining wall 36'.

The plug terminals 33 are mounted on a plug terminal seat 34 which includes a base part 341 formed with a plurality of terminal passageways 344 for receiving the plug terminals 33 and having a contact portion 345 which projects into the

US 6,508,678 B1

3

first mating portion 36, and a positioning block 342 projecting from the base part 341, crossing the terminal passageways 344, and having a plurality of grooves aligned with the passageways 344 to confine the plug terminals 33. A pair of positioning recesses 343 are formed in two opposite sides of the positioning block 342 to engage the positioning tongues 362 when the plug terminal seat 34 is disposed in the inner shell 37. An elastic sleeve 39 is sleeved on a connecting end 51 of the cable 5, and is connected to the plug housing 30 for protecting the cable 5 from being bent.

Referring now to FIGS. 6 and 7, in combination with FIGS. 2 to 5, the receptacle 4 includes a metal receptacle housing 45 adapted to be mounted on a printed circuit board (not shown) and having a substantially U-shaped supporting portion 451' and a second mating portion 453 defined by a multi-sided second confining wall 453' and projecting from a front end of the supporting portion 451', a receptacle terminal seat 41' mounted on the supporting portion 451', and a plurality of receptacle terminals 43 mounted on the receptacle terminal seat 41'. The supporting portion 451' of the receptacle housing 45 has a bight part 452 and two opposite arms 451 projecting from two opposite sides of the bight part 452 in directions substantially perpendicular to the bight part 452. A cover plate 456 projects from a rear end 454 of the supporting portion 451', and has two opposite legs formed with locking recesses 459. A pair of lugs 450 project from one end of each arm 451 of the supporting portion 451' of the receptacle housing 45 for engaging the printed circuit board. A pair of elongated slots 455 are formed in the arms 451, and open at the rear end 454 of the supporting portion 451'. A pair of tongues 460 project outwardly from the arms 451 between the elongated slot 455 and the lugs 450. The bight part 452 of the supporting portion 451' is punched or is stamped to form a main spring arm 457 and a pair of secondary spring arms 458 thereon. The main spring arm 457 has a front end formed with a bent section 457'.

The receptacle terminal seat 41' includes a rectangular positioning body 41 and a base part 42' projecting from a front face 443 of the positioning body 41 and having a contact portion 42 extending into the second mating portion 453 to mate with the contact portion 345 of the base part 341 of the plug terminal seat 34. A plurality of receptacle terminal passageways 446 are formed in the base part 42' for receiving the receptacle terminals 43. The base part 42' has a side wall 445 defining one side of each receptacle terminal passageway 446 and formed with a plurality of openings 447 that are respectively aligned with and spatially communicated with the receptacle terminal passageways 446. A pair of protrusions 448 respectively project from two opposite sides of the positioning body 41 to engage the elongated slots 455 in the arms 451 of the supporting portion 451' when the assembly of the receptacle terminal seat 41 and the receptacle terminals 43 is disposed in the receptacle housing 45. Each receptacle terminal 43 has a spring arm 436 disposed in one of the receptacle terminal passageways 446 and having a front end formed with a bent portion 437 that protrudes through the respective opening 447 in the side wall 445 of the base part 42', and an L-shaped solder tail 439 extending from the spring arm 436 through the positioning body 41 and adapted to be soldered to the printed circuit board (not shown). The legs of the cover plate 456 are bent at an angle of 90° to permit the locking recesses 459 to engage the tongues 460 at the arms 451 of the supporting portion 451' after the assembly of the receptacle terminal seat 41 and the receptacle terminals 43 is disposed in the receptacle housing 45.

Referring now to FIGS. 9 and 10, in combination with FIGS. 3 and 6, each of the first and second confining walls

4

36', 453' has opposite first and second sides 371, 372' (481, 482), a pair of opposite third sides 373 (483) respectively connected to two opposite ends of the first side 371 (481), a pair of fourth sides 374 (484) respectively connected to two opposite ends of the second sides 372 (482), and a pair of fifth sides 375 (485) each extending between and interconnecting one of the third sides 373 (483) and one of the fourth sides 374 (484). The first side 371 (481) is longer than the second side 372 (482). The width between the third sides 373 (483) is greater than that between the fourth sides 374 (484). The fifth sides 375 (485) are angled away from each other while extending from the fourth sides 374 (484) to the third sides 373 (483). The first and second sides 371, 372 (481, 482) are substantially parallel. The third sides 373 (483) are substantially perpendicular to the first side 371 (481). The fourth sides 374 (484) extend obliquely and respectively from the opposite ends of the second side 372 (482). The fifth sides 375, (485) are respectively and substantially perpendicular to the third sides 373 (483). The shortest distance (indicated as reference mark H1 shown in FIG. 9 or H1' in FIG. 10) from one of, two opposite ends of each third side 373 (483), that is distal from the first side 371 (481), to a plane defined by the second side 372 (482) is smaller than the distance (indicated as reference mark W1 shown in FIG. 9 or W1' in FIG. 10) from one of the opposite ends of the second side 372 (482), that is adjacent to that third side 373 (483), to a plane defined by that third side 373 (483). The locking opening 369 is formed at the first side 371 of the first confining wall 36'.

Referring now to FIG. 8, in combination with FIGS. 3 and 7, the locking opening 369 engages the bent section 457' of the main spring arm 457 of the bight part 452, and each plug terminal 33 abuts against the bent portion 437 of the respective receptacle terminal 43 when the plug 3 is plugged into the receptacle 4.

FIGS. 11 and 12 respectively illustrate a modified receptacle 4' and a modified plug 3' which are similar to the previous receptacle 4 and the previous plug 3 except that the fourth sides 374' (484') are substantially perpendicular to the second side 372' (482'), that each fifth side 375' (485') is oblique relative to the respective third side 373' (483') and the respective fourth side 374' (484'), and that the shortest distance (indicated as reference mark H2 shown in FIG. 11 or H2' in FIG. 12) from one of two opposite ends of each third side 373' (483'), that is distal from the first side 371' (481') to the plane defined by the second side 372' (482') is greater than the distance (indicated as reference mark W2 shown in FIG. 11 or W2' in FIG. 12) from an adjacent one of the opposite ends of the second side 372' (482') to the plane defined by that third side 373' (483').

FIG. 13 illustrates another modified receptacle 4" which is a combination of the previous receptacle 4 and the previous modified receptacle 4' that are stacked one above the other.

Referring now to FIGS. 3 and 6, the plug terminals 33 include spaced apart two first power terminals 331, a first detecting terminal 335 disposed adjacent and integrally formed with one of the power terminals 331, and two spaced apart data terminals 333, 334. The receptacle terminals 43 are spaced apart from each other, and include two second power terminals 431, a second detecting terminal 435 disposed adjacent to one of the power terminals 431, and two data terminals 433, 434. The second detecting terminal 435 is electrically connected to the adjacent one of the second power terminals 431 via the interconnected one of the first power terminals 331 and the first detecting terminal 335 when the plug 3 and the receptacle 4 are coupled together,

thereby permitting the printed circuit board to distinguish the type of plug that is connected thereto.

With the invention thus explained, it is apparent that various modifications and variations can be made without departing from the spirit of the present invention. It is therefore intended that the invention be limited only as recited in the appended claims.

I claim:

1. An electrical connector assembly, comprising:

a plug that includes a plug housing having a first mating portion, and a plurality of plug terminals mounted inside said plug housing, said first mating portion being defined by a multi-sided first confining wall; and

a receptacle that includes a receptacle housing having a second mating portion to mate with said first mating portion, and a plurality of receptacle terminals mounted inside said receptacle housing, said second mating portion being defined by a multi-sided second confining wall,

each of said first and second confining walls having opposite first and second sides, a pair of opposite third sides respectively connected to two opposite ends of said first side, a pair of fourth sides respectively connected to two opposite ends of said second side, and a pair of fifth sides each extending between and interconnecting one of said third sides and one of said fourth sides, said first side being longer than said second side, said first and second sides being longer than each of said third sides, the width between said third sides being greater than that between said fourth sides, said fifth sides being angled away from each other while extending from said fourth sides to said third sides;

wherein said first and second sides are substantially parallel, and said third sides are substantially perpendicular to said first side; and

wherein said fourth sides extend obliquely from said second side.

2. The electrical connector assembly of claim 1, wherein said fifth sides are respectively and substantially perpendicular to said third sides.

3. The electrical connector assembly of claim 2, wherein each of said third sides has two opposite ends, the shortest distance from one of said opposite ends of said third side, that is distal from said first side, to a plane defined by said second side being smaller than that from one of said opposite ends of said second side, that is adjacent to said one of said opposite ends of said third side, to a plane defined by said third side.

4. The electrical connector assembly of claim 1, wherein said plug terminals include a first power terminal and a first detecting terminal which is electrically connected to said first power terminal, and said receptacle terminals include a second power terminal and a second detecting terminal which is spaced apart from said second power terminal and which is electrically connected to said second power terminal via said first power terminal and said first detecting terminal when said first and second mating portions are coupled together.

5. The electrical connector assembly of claim 4, wherein said first power terminal and said first detecting terminal are integrally formed and are punched from a metal plate.

* * * * *