

1 John E. Lord (CA SBN 216111)  
Email: jlord@onellp.com  
2 ONE LLP  
3 9301 Wilshire Blvd, Penthouse Suite  
4 Beverly Hills, CA 90210  
5 Telephone: (310) 866-5157  
6 Facsimile: (310) 943-2085

7 Joseph K. Liu (CA SBN 216227)  
Email: jliu@onellp.com  
8 Christopher W. Arledge (CA SBN 200767)  
Email: carledge@onellp.com  
9 ONE LLP  
10 4000 MacArthur Blvd  
11 East Tower, Suite 500  
12 Newport Beach, CA 92660  
13 Telephone: (949) 502-2870  
14 Facsimile: (949) 258-5081

15 *Counsel for Plaintiff Interface Linx, LLC*

16 UNITED STATES DISTRICT COURT  
17 CENTRAL DISTRICT OF CALIFORNIA  
18 WESTERN DIVISION

19 INTERFACE LINX, LLC, a  
20 California limited liability company,  
21 Plaintiff,

22 v.

23 PIONEER ELECTRONICS (USA),  
24 INC., a Delaware corporation and  
25 PIONEER CORPORATION, a foreign  
26 corporation,

27 Defendants.

Case No. 2:17-cv-03191

**COMPLAINT FOR PATENT  
INFRINGEMENT**

1 For its Complaint against Defendants Pioneer Electronics (USA), Inc.  
2 (“Pioneer USA”) and Pioneer Corporation (“Pioneer”) (collectively “Defendants”),  
3 Plaintiff Interface Linx, LLC (“Interface” or “Plaintiff”) alleges as follows:

4 **THE PARTIES**

5 1. Plaintiff Interface Linx, LLC (“Interface”) is a California limited  
6 liability company having a principal place of business at 35 Hugus Alley, Suite 210,  
7 Pasadena, CA 91103.

8 2. On information and belief, Pioneer Electronics (USA), Inc.,  
9 (“Pioneer USA”) is a corporation organized under the laws of Delaware and has its  
10 principal place of business at 1925 E. Dominguez Street, Long Beach, California  
11 90810 and has appointed CSC - Lawyers Incorporating Service, 2710 Gateway Oaks  
12 Dr Ste 150N, Sacramento CA 95833, as its agent for service of process. Pioneer  
13 USA is a wholly-owned subsidiary of Pioneer.

14 3. On information and belief, Pioneer Corporation (“Pioneer  
15 Corporation”) is a corporation organized under the laws of Japan and has its  
16 principal place of business at 28-8, Honkomagome 2-chome, Bunkyo-ku, Tokyo  
17 113-0021, Japan.

18 **JURISDICTION AND VENUE**

19 4. This is a civil action for patent infringement arising under the Patent  
20 Act of the United States, 35 U.S.C. §§ 1 *et seq.* This court has subject matter  
21 jurisdiction of such federal question claims pursuant to 28 U.S.C. §§ 1331 and  
22 1338(a).

23 5. This Court has personal jurisdiction over Defendants in this action  
24 because Defendants have committed acts within this district giving rise to this action  
25 and has established minimum contacts with this forum such that the exercise of  
26 jurisdiction would not offend traditional notions of fair play and substantial justice.  
27 Defendants, directly and indirectly, have committed and continue to commit acts of  
28 infringement in this district by, among other things, offering to sell and selling

1 products and/or services that infringe the asserted patent.

2 6. Venue is proper under 28 U.S.C. §§ 1391(b), 1391(c) and 1400(b) in  
3 that the acts and transactions complained of herein were conceived, carried out,  
4 made effective, and had effect within the State of California and within this district,  
5 among other places. Defendants reside in this district by virtue of their business  
6 activities in this district and having committed acts of direct and indirect  
7 infringement in this district.

8 **INTERFACE’S PATENT-IN-SUIT**

9 7. On January 21, 2003, the United States Patent & Trademark Office  
10 duly and legally issued United States Letters Patent No. 6,508,678 (“the ’678  
11 Patent”), entitled “Electrical Connector Assembly.”

12 8. The ’678 Patent is owned by Interface.

13 **FIRST CLAIM FOR RELIEF**  
14 **AGAINST DEFENDANTS FOR DIRECT, INDUCING, AND**  
15 **CONTRIBUTORY INFRINGEMENT**

16 Plaintiff incorporates herein by reference the allegations set forth in  
17 paragraphs 1-8 of the Complaint as though fully set forth herein.

18 9. A true and correct copy of the ’678 Patent is attached as Exhibit A and  
19 incorporated herein by reference.

20 10. Defendants have been and now is infringing at least claim 1 of the  
21 ’678 Patent in this district, and elsewhere in the United States by, among other  
22 things; making, using, importing, offering for sale, and/or selling products that  
23 infringe the ’678 Patent.

24 11. Defendants make, use and sell, within the United States, a plurality of  
25 electrical connector assemblies which are integrated into a diverse class of electronic  
26 products that infringe the ’678 Patent (collectively referred to hereinafter as  
27 “Accused Systems”), and which are designed to the specifications of HDMI Type A.

28 12. The electrical connector assembly of claim 1 offers significant

1 improvements in plug and receptacle design, which greatly improve ease of  
2 connectivity and the potential for data transfer once the connection is made. The  
3 physical design, envisioned with great specificity by the '678 Patent, offered such  
4 improvements over the prior art that the HDMI standards utilized this design to  
5 create the Type A plug and receptacle found on the vast majority of electronic  
6 devices today.

7         13. Defendants make and sell products that utilize the electrical connector  
8 assembly of the '678 Patent. These Accused Systems include, for example and  
9 without limitation, Defendants' A/V Receivers, such as the SC-LX801 9.2-ch Class  
10 D<sup>3</sup> Network AV Receiver; Defendants' Vehicle Receivers, such as the AVIC-  
11 8201NEX Flagship In-Dash Navigation AV Receiver with 7" WVGA Capacitive  
12 Touchscreen Display and included ND-BC8 Back-Up Camera; and Defendants'  
13 Blu-ray Players, such as the BDP-80FD Elite 3D-Compatible Streaming Blu-ray  
14 Disc™ Player.

15         14. Defendants' Accused Systems are designed with the first element of  
16 claim 1. Specifically, Defendants' Accused Systems require both plugs and  
17 receptacles to form the electrical connector assembly and transfer data, including  
18 audio and video, over the HDMI connection. This plug must include plug housing  
19 with the mating portion within, the mating portion defined by a multi-sided  
20 confining wall. An example of this plug can be found at Defendants' website  
21 <http://www.pioneerelectronics.com/PUSA/Car/Accessories/Smartphone-and-iPod->  
22 [Cables/CD-IH202](http://www.pioneerelectronics.com/PUSA/Car/Accessories/Smartphone-and-iPod-Cables/CD-IH202), as shown below:

23  
24  
25  
26  
27  
28



1  
2  
3  
4  
5  
6  
7  
8  
9  
10  
11  
12  
13  
14  
15  
16  
17  
18  
19  
20  
21  
22  
23  
24  
25  
26  
27  
28

15. Defendants’ Accused Systems are further designed with the second element of claim 2. Specifically, Defendants’ Accused Systems require both plugs and receptacles to form the electrical connector assembly and transfer data, including audio and video, over the HDMI connection. This receptacle must include a mating portion with terminals mounted inside within, the mating portion defined by a multi-sided confining wall. An example of this receptacle can be found at Defendants’ website <http://www.pioneerelectronics.com/PUSA/Home/AV-Receivers/Elite+Receivers/SC-LX801>, as shown below:

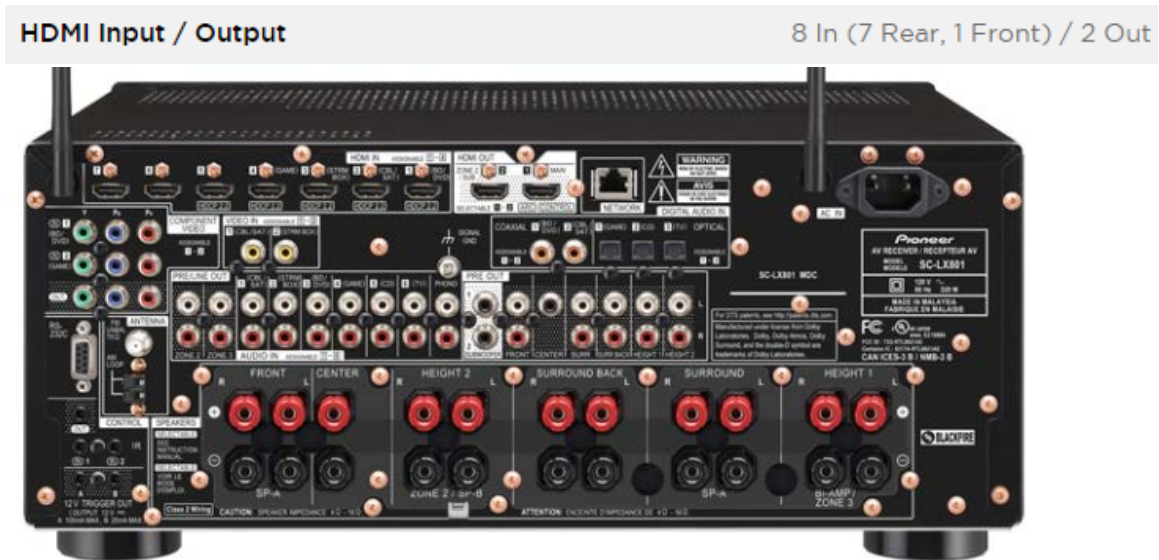

1 16. Defendants' Accused Systems are further designed with the third  
2 element of claim 1. HDMI Type A plugs and receptacles, like those used by  
3 Defendants in their Accused Systems, are designed with a plurality of confining  
4 walls that are specifically designed and oriented. In order for a plug and receptacle  
5 to be used together, their confining walls must utilize the same shape, with the plug  
6 being sized smaller in order to fit within the receptacle.

7 17. In HDMI Type A connectors, like those designed into Defendants'  
8 Accused Systems, the first and second sides are found opposite of each other and the  
9 first side is longer than the second side. A pair of third sides are then connected to  
10 the opposite ends of the first side, each of the pair being shorter than either the first  
11 or second side. A pair of fourth sides are then connected to the opposite ends of the  
12 second side, but the width between the two fourth sides must be less than that  
13 between the two third sides. Finally, a pair of fifth sides are then connected between  
14 to connect the third and fourth side of their respective sides, the fifth sides must be  
15 angled away from each other while extending from the fourth sides to the third sides  
16 that they connect to. This is illustrated by the following diagram, which has been  
17 color coded to follow the claim language and has had each of the sides of the  
18 receptacle labeled in accordance with the claim language.

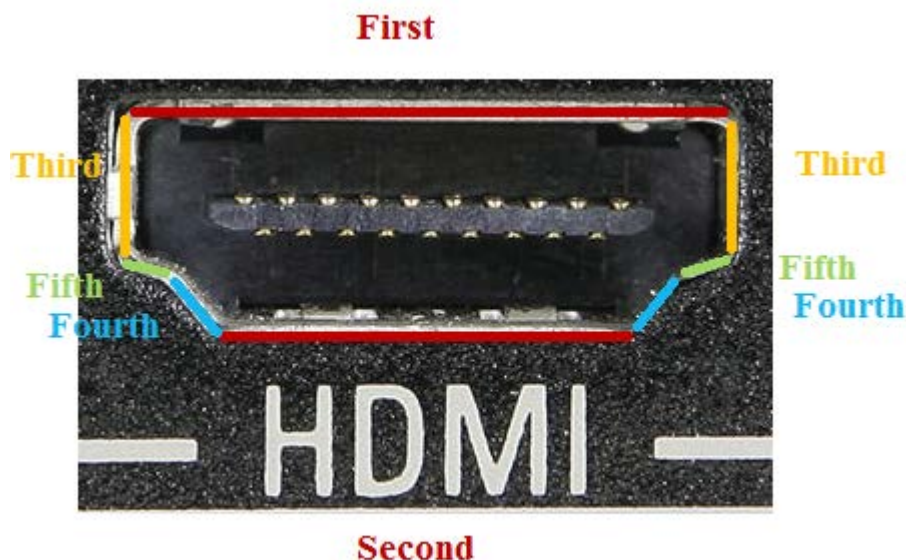

1 18. Defendants' Accused Systems are further designed with the fourth  
2 element of claim 1. As shown in the figure above, in HDMI Type A connectors, like  
3 those designed into Defendants' Accused Systems, the first and second sides run  
4 substantially parallel to each other. Further, the third sides are substantially  
5 perpendicular to the first side.

6 19. Defendants' Accused Systems are further designed with the final  
7 element of claim 1. As shown in the figure above, In HDMI Type A connectors,  
8 like those designed into Defendants' Accused Systems, the fourth sides extend  
9 obliquely from each end of the second side.

10 20. The '678 Patent has been cited by over 50 issued patents and  
11 published patent applications as relevant prior art.

12 21. By making, using, selling, and offering for sale such devices, and all  
13 like products that are covered by one or more claims of the '678 Patent, including at  
14 least claim 1, Defendants have infringed and continue to infringe the '678 Patent,  
15 including infringement under 35 U.S.C. § 271.

16 22. On information and belief, Defendants have also indirectly infringed  
17 and continue to indirectly infringe the '678 Patent by actively inducing direct  
18 infringement by other persons, such as their customers and end users, who operate  
19 systems that embody or otherwise practice one or more of the claims of the '678  
20 Patent, when Defendants had knowledge (or willful blindness thereto) of the '678  
21 Patent and that the activities they were inducing would result in direct infringement  
22 by others and intended that their actions would induce direct infringement by others.  
23 Defendants intended and were aware that the normal and customary use of the  
24 Accused Systems would infringe the '678 Patent.

25 23. Defendants intended to induce other persons, such as their customers  
26 and end users, to directly infringe the '678 Patent by (1) advising or directing them  
27 to make, use, sell, or import the Accused Systems, (2) advertising and promoting the  
28 use of the Accused Systems, and (3) distributing instructions for using the Accused

1 Systems, all in an infringing manner. On information and belief, Defendants  
2 engaged in such inducement to promote the sales of the Accused Systems, e.g.,  
3 through user manuals, product support, and marketing materials to actively induce  
4 the users of the accused products to infringe the '678 Patent.

5       24. On information and belief, Defendants have and continue to  
6 contribute to infringement other persons, such as their customers and end users, to  
7 directly infringe at least claim 1 of the '678 Patent. Defendants contribute to  
8 infringement by offering to sell, selling within the United States, or importing into  
9 the United States materials and apparatus for use with in practicing at least claim 1  
10 of the '678 Patent. Specifically, on information and belief, Defendants know that  
11 their products with a HDMI receptacle, for example, and materials and apparatus  
12 designed for use with this receptacle, constitute a material and component part of the  
13 invention of the '678 Patent, and is infringing, and that it is not a staple article or  
14 commodity of commerce suitable for substantial non-infringing use, and it has no  
15 use apart from infringing the '678 Patent.

16       25. On information and belief, Defendants have had knowledge of the  
17 '678 Patent since at least the filing of this Complaint.

18       26. On information and belief, Defendants will continue to infringe the  
19 '678 Patent unless enjoined by this Court.

20       27. As a direct and proximate result of Defendants' infringement of the  
21 '678 Patent, Interface has been and continues to be, damaged in an amount yet to be  
22 determined, but in no event less than a reasonable royalty for the use made of the  
23 invention by Defendants, together with interest and costs as fixed by the Court.

24       28. Unless a preliminary and permanent injunction are issued enjoining  
25 Defendants and their officers, agents, servants and employees, and all others acting  
26 on their behalf or in concert with Defendants, from infringing the '678 Patent,  
27 Interface, will be greatly and irreparably harmed.

28



**PRAYER FOR RELIEF**

WHEREFORE, Interface prays for judgment against Defendants as follows:

- (1) For a judicial decree that Defendants have infringed, and continue to infringe, the '678 Patent;
- (2) For a judicial decree that Defendants, their respective subsidiaries, officers, agents, servants, employees, licensees, and all other persons or entities acting or attempting to act in active concert or participation with it or acting on their behalf, be preliminarily and permanently enjoined from further infringement of the '678 Patent;
- (3) For a judicial decree that orders Defendants to account for and pay to Interface all damages caused to Interface by reason of Defendants' infringement pursuant to 35 U.S.C. Section 284, including enhanced damages;
- (4) For a judicial decree finding that this is an exceptional case within the meaning of 35 U.S.C. § 285 and awarding to Plaintiff its reasonable attorneys' fees;
- (5) For a judicial decree that Defendants pay an ongoing royalty in an amount to be determined for continued infringement after the date of judgment;
- (6) For a judicial decree awarding to Interface pre-judgment and post-judgment interest on the damages caused to it by Defendants' infringement; and
- (7) For any such other and further relief as the Court may deem just and proper under the circumstances.

Dated: April 27, 2017

**ONE LLP**

By: /s/John E. Lord  
John E. Lord  
Attorneys for Plaintiff,  
Interface Linx, LLC

1  
2  
3  
4  
5  
6  
7  
8  
9  
10  
11  
12  
13  
14  
15  
16  
17  
18  
19  
20  
21  
22  
23  
24  
25  
26  
27  
28

**DEMAND FOR JURY TRIAL**

Plaintiff Interface hereby demands trial by jury in this action.

Dated: April 27, 2017

**ONE LLP**

By: /s/John E. Lord

John E. Lord  
Attorneys for Plaintiff,  
Interface Linx, LLC

# **EXHIBIT A**



US006508678B1

(12) **United States Patent**  
**Yang**

(10) **Patent No.:** **US 6,508,678 B1**  
(45) **Date of Patent:** **Jan. 21, 2003**

(54) **ELECTRICAL CONNECTOR ASSEMBLY**

(75) Inventor: **Sheng-Ho Yang**, Taipei Hsien (TW)

(73) Assignee: **Advanced Connecteck Inc.**, Taipei Hsien (TW)

(\*) Notice: Subject to any disclaimer, the term of this patent is extended or adjusted under 35 U.S.C. 154(b) by 64 days.

(21) Appl. No.: **09/653,129**

(22) Filed: **Aug. 31, 2000**

(51) **Int. Cl.**<sup>7</sup> ..... **H01R 13/64**

(52) **U.S. Cl.** ..... **439/677; 439/607**

(58) **Field of Search** ..... 439/607, 610, 439/676, 677, 680, 682, 101, 108, 924.1

(56) **References Cited**

**U.S. PATENT DOCUMENTS**

3,710,197	A	*	1/1973	Olds et al.	.....	317/118
5,046,960	A	*	9/1991	Fedder	.....	439/108
5,051,099	A	*	9/1991	Pickles et al.	.....	439/108
5,634,819	A	*	6/1997	Pan et al.	.....	439/637
5,647,765	A	*	7/1997	Haas et al.	.....	439/609
5,651,685	A	*	7/1997	Brinkman et al.	.....	439/79
6,041,498	A	*	3/2000	Hillbish et al.	.....	29/883
6,171,125	B1	*	1/2001	Kirkendall	.....	439/218

6,261,129	B1	*	7/2001	Kusagaya	.....	439/677
6,280,209	B1	*	8/2001	Bassler et al.	.....	439/101
6,322,395	B1	*	11/2001	Nishio et al.	.....	439/607
6,386,918	B1	*	5/2002	Zheng et al.	.....	439/607

**FOREIGN PATENT DOCUMENTS**

GB 1029090 \* 5/1966 ..... 439/677

\* cited by examiner

*Primary Examiner*—Tulsidas Patel

*Assistant Examiner*—Thanh-Tam Le

(74) *Attorney, Agent, or Firm*—Merchant & Gould P.C.

(57) **ABSTRACT**

An electrical connector assembly includes a plug having a first mating portion defined by a multi-sided first confining wall, and a receptacle having a second mating portion defined by a multi-sided second confining wall. Each of the first and second confining walls has opposite first and second sides, a pair of opposite third sides respectively connected to two opposite ends of the first side, a pair of fourth sides respectively connected to two opposite ends of the second sides, and a pair of fifth sides each extending between and interconnecting one of the third sides and one of the fourth sides. The first side is longer than the second side. The width between the third sides is greater than that between the fourth sides. The fifth sides are angled away from each other while extending from the fourth sides to the third sides.

**5 Claims, 9 Drawing Sheets**

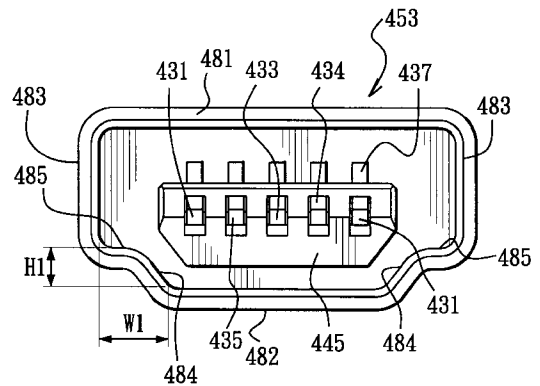
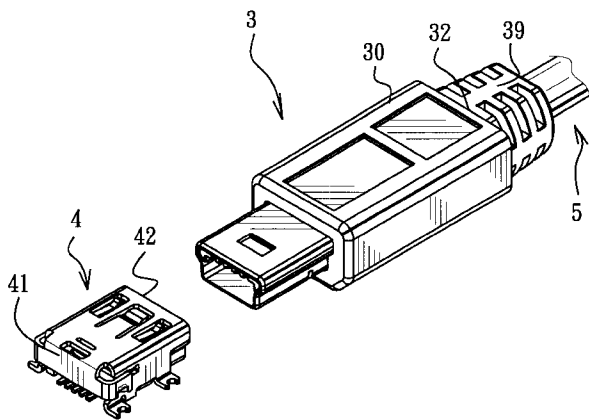

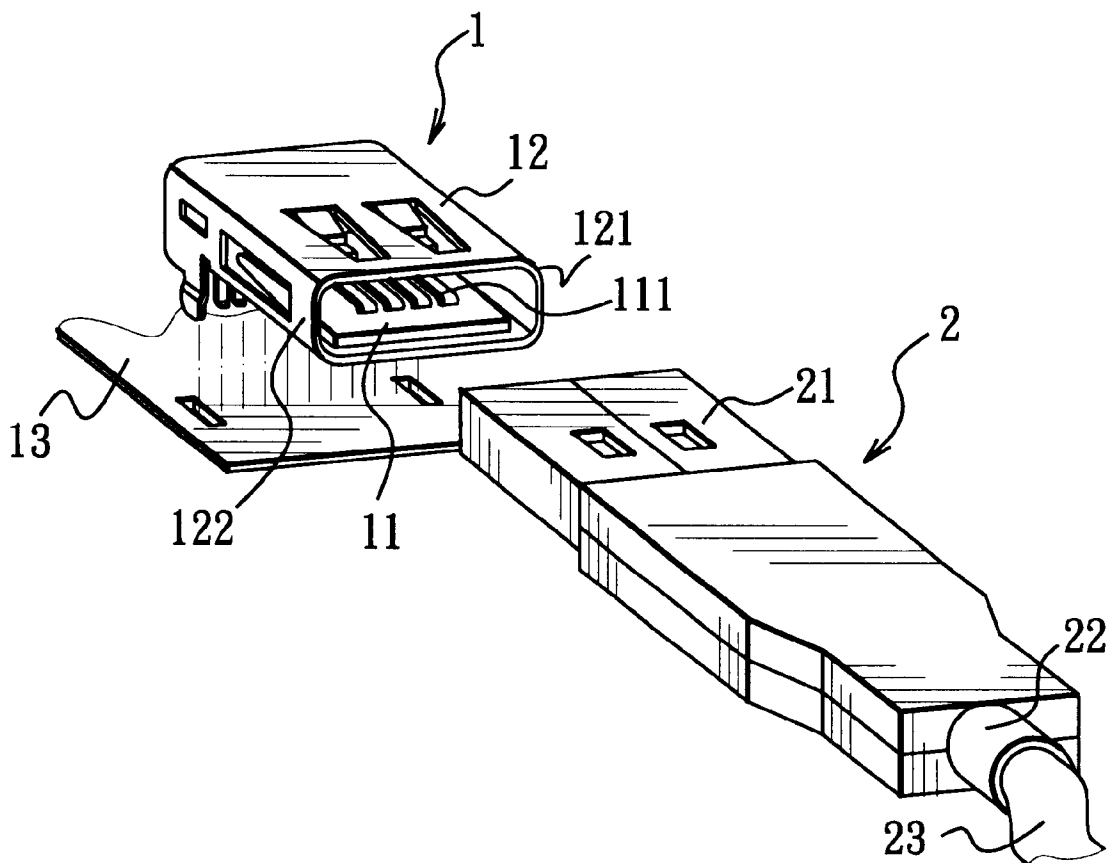
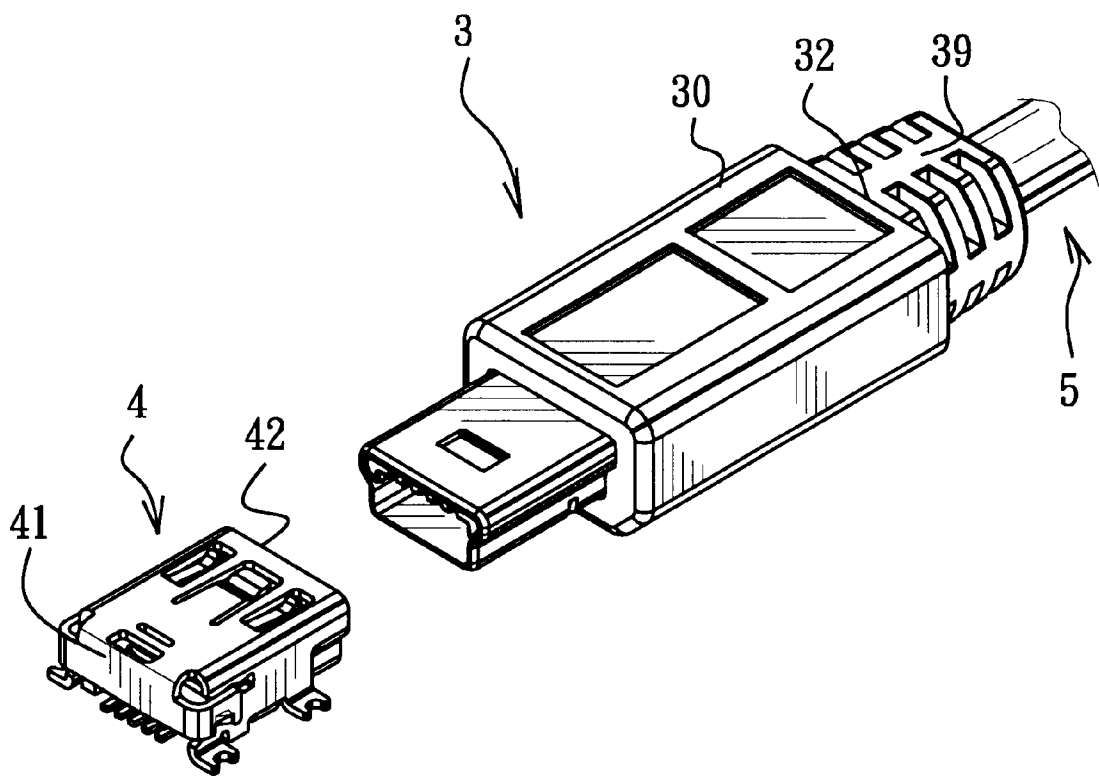

FIG. 1  
PRIOR ART



F I G. 2

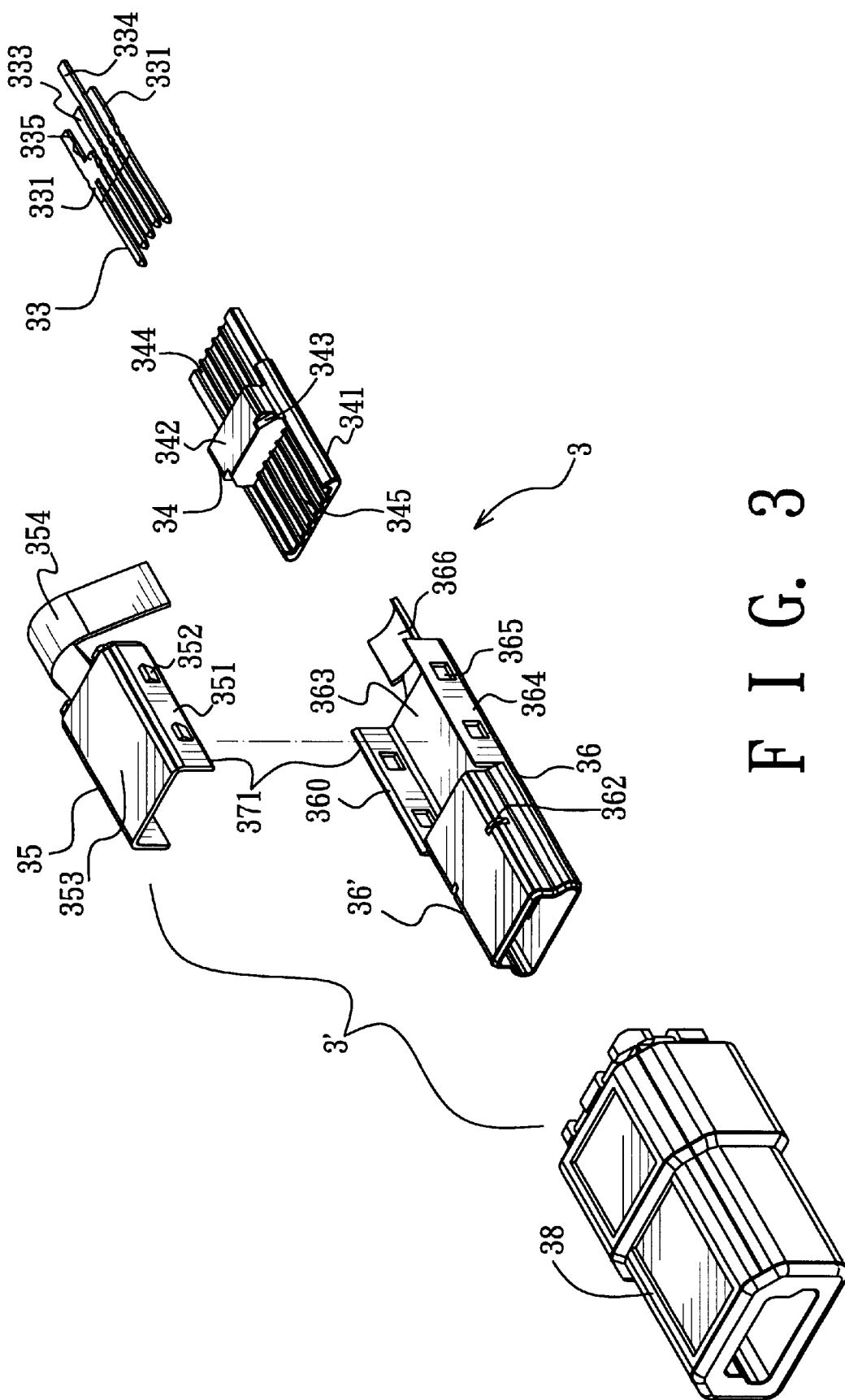
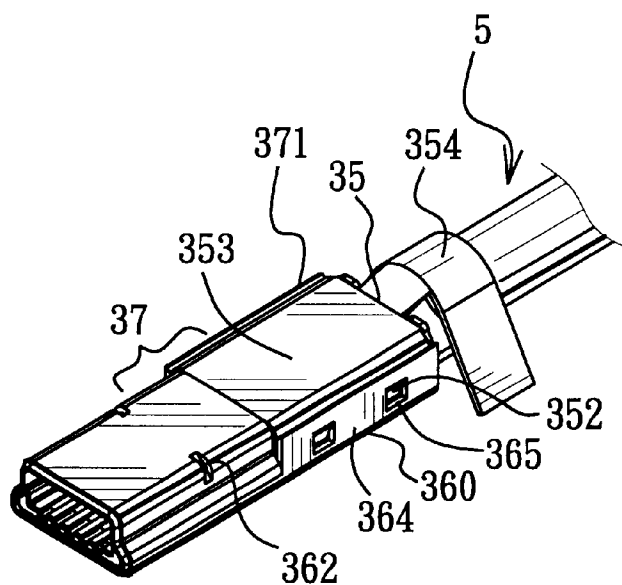
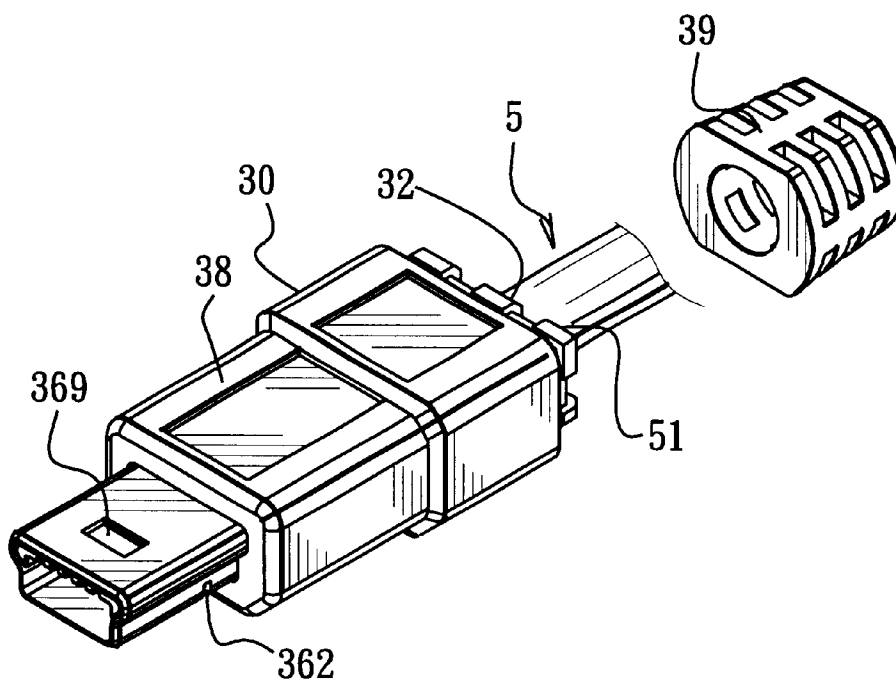

FIG. 3



F I G. 4



F I G. 5



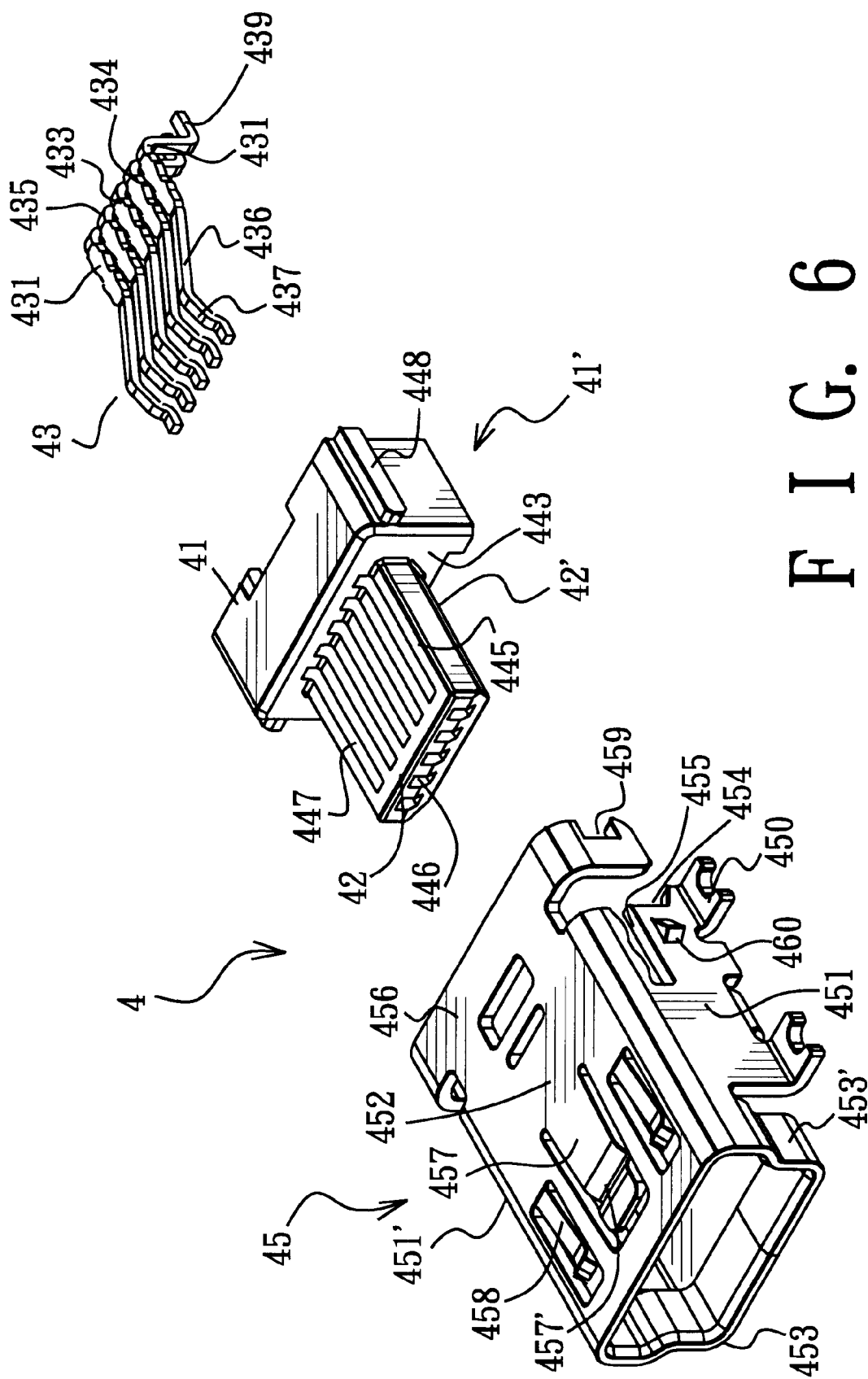

FIG. 6

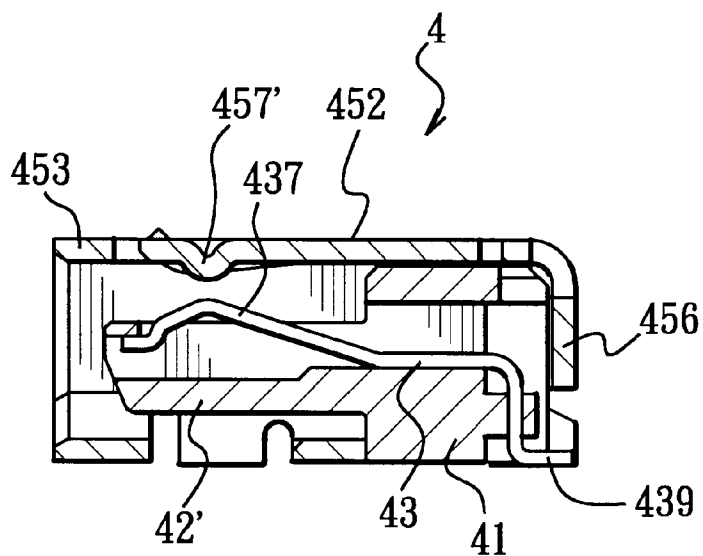

FIG. 7

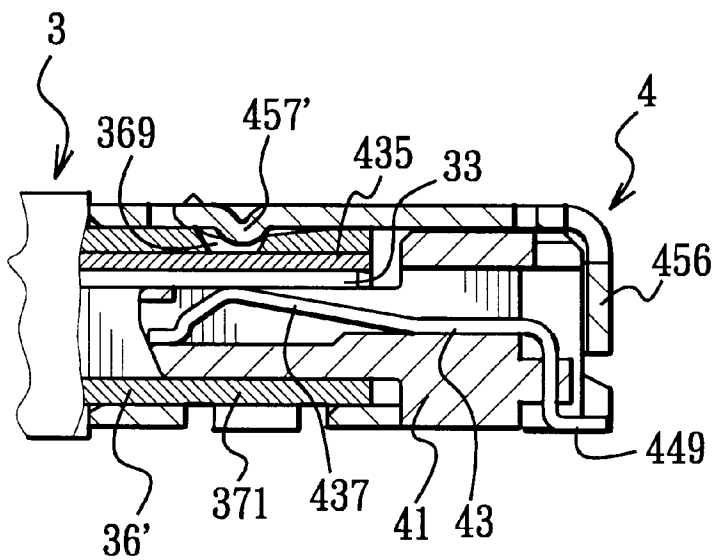
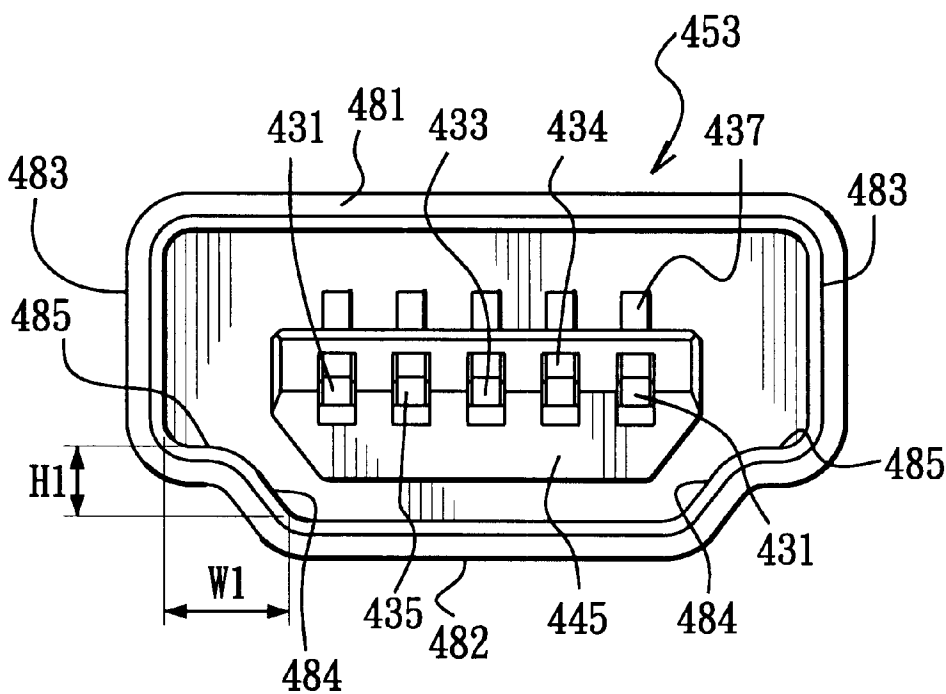
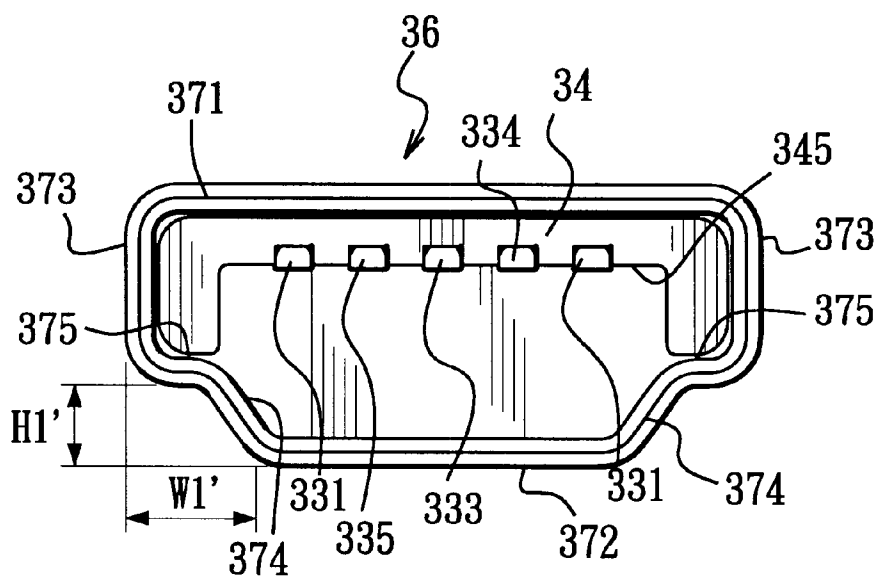

FIG. 8



F I G. 9



F I G. 10

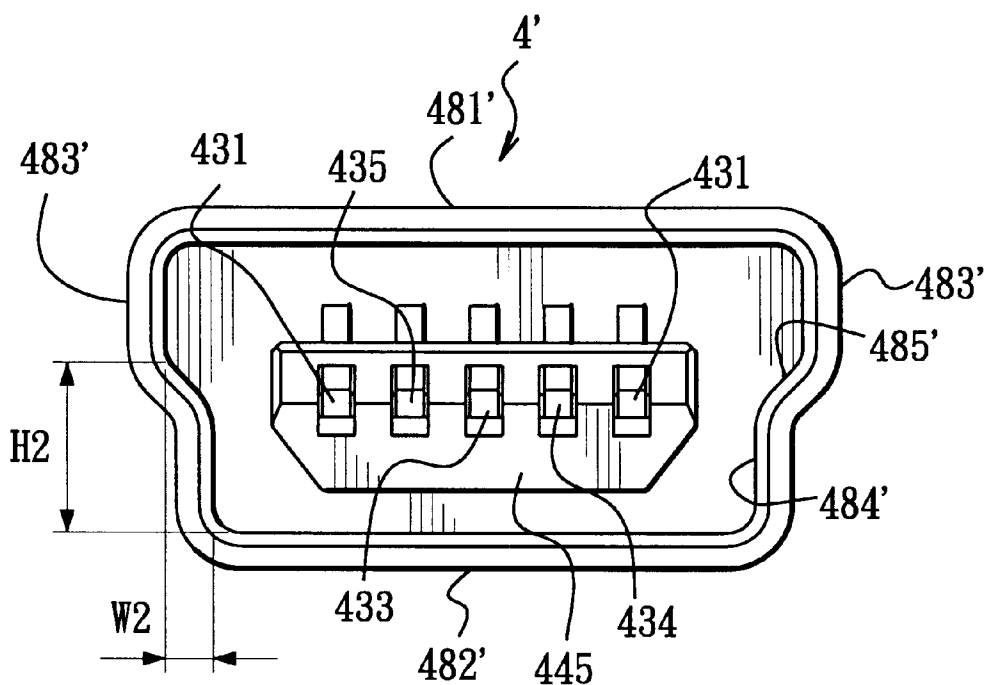

F I G. 11

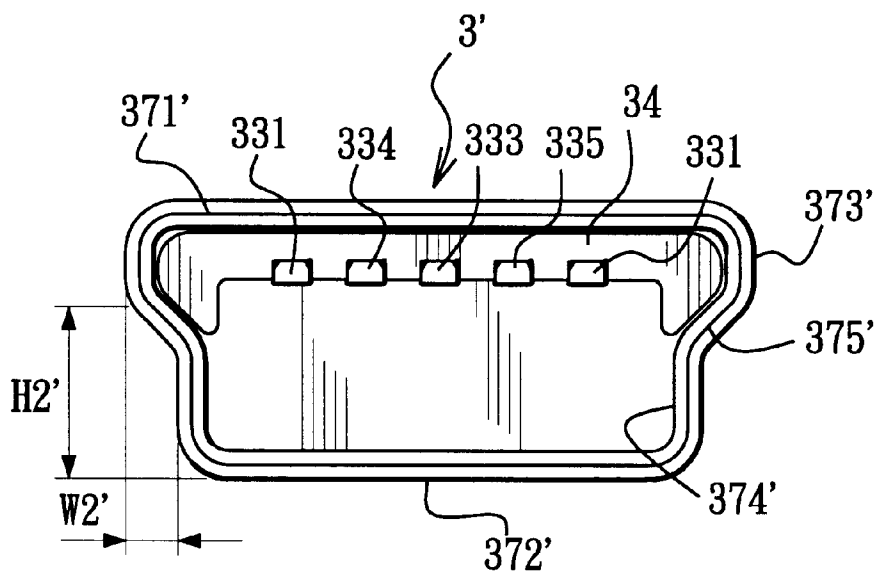

F I G. 12

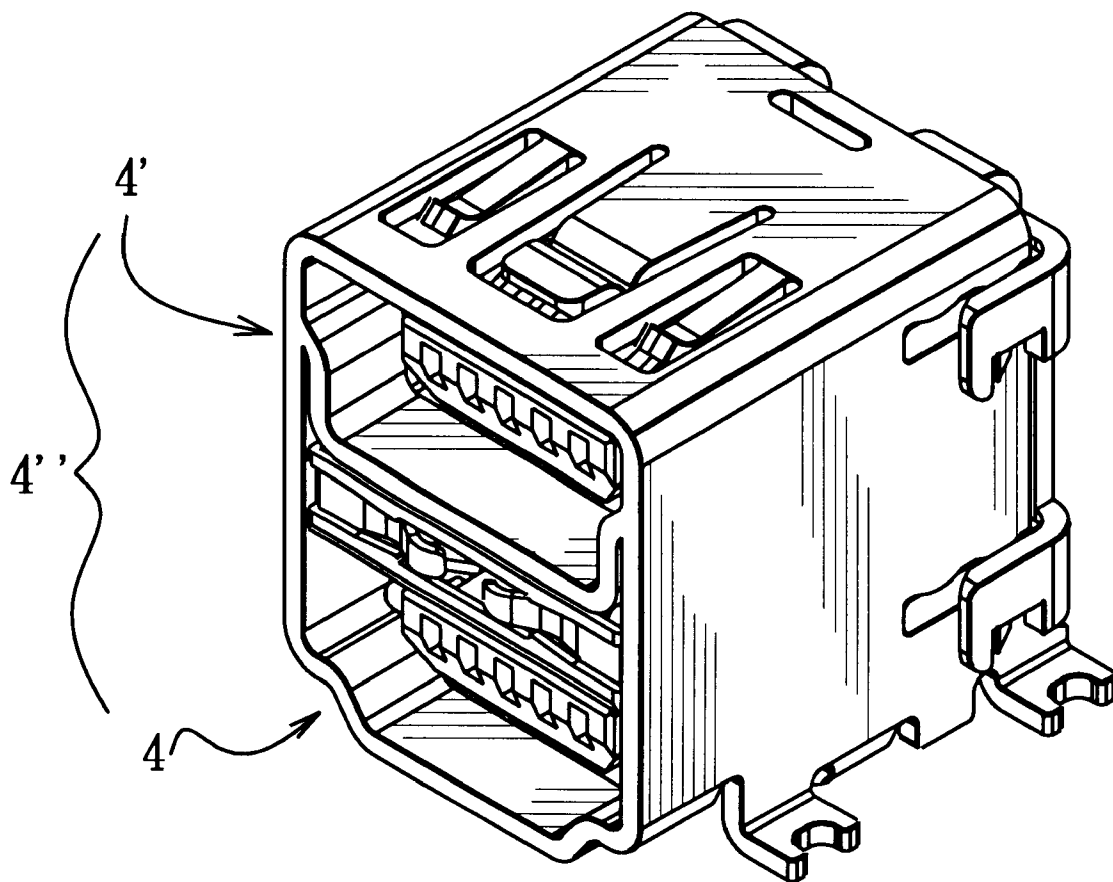

F I G. 13

US 6,508,678 B1

1

**ELECTRICAL CONNECTOR ASSEMBLY****BACKGROUND OF THE INVENTION**

## 1. Field of the Invention

This invention relates to an electrical connector assembly, more particularly to a USB type electrical connector assembly.

## 2. Description of the Related Art

FIG. 1 illustrates a conventional USB (Universal Serial Bus Connector) electrical connector assembly that serves as a medium for data transmission in a computer. The assembly includes a receptacle 1 with a complementary plug 2. The receptacle 1 includes a receptacle housing 12 having a receptacle mating portion 122 formed with a substantially rectangular opening 121 for receiving the plug 2, a receptacle terminal seat 11 disposed in the receptacle housing 12, and a plurality of receptacle terminals 111 mounted on the receptacle terminal seat 11 and having ends adapted to be-connected to a printed circuit board 13. The plug 2 includes a plug housing and a plurality of plug terminals (not shown) mounted in the plug housing. The plug housing has a plug mating portion 21 adapted to mate with the receptacle mating portion 122 and having a cable connecting end 22 adapted to be connected to a cable 23.

The cable 23 normally has two opposite ends provided with the same plugs 2 that respectively serve as data input and output connectors. As such, there is a tendency to plug a wrong one of the plugs 2 into the receptacle 1 of a printed circuit board when using the cable 23 to connect an electrical device to the printed circuit board, thereby hindering data transmission between the electrical device and the printed circuit board.

**SUMMARY OF THE INVENTION**

Therefore, the object of the present invention is to provide an electrical connector assembly that is capable of overcoming the aforementioned drawback.

According to the present invention, an electrical connector assembly comprises a plug that includes a plug housing having a first mating portion, and a plurality of plug terminals mounted inside the plug housing, the first mating portion being defined by a multi-sided first confining wall; and a receptacle that includes a receptacle housing having a second mating portion to mate with the first mating portion, and a plurality of receptacle terminals mounted inside the receptacle housing, the second mating portion being defined by a multi-sided second confining wall, each of the first and second confining walls having opposite first and second sides, a pair of opposite third sides respectively connected to two opposite ends of the first side, a pair of fourth sides respectively connected to two opposite ends of the second sides, and a pair of fifth sides each extending between and interconnecting one of the third sides and one of the fourth sides, the first side being longer than the second side, the width between the third sides being greater than that between the fourth sides, the fifth sides being angled away from each other while extending from the fourth sides to the third sides.

**BRIEF DESCRIPTION OF THE DRAWINGS**

In drawings which illustrate embodiments of the invention,

FIG. 1 is an exploded perspective view of a conventional electrical connector assembly adapted to be connected to a printed circuit board;

2

FIG. 2 is an exploded perspective view of an electrical connector assembly embodying this invention;

FIG. 3 is an exploded perspective view of a plug of the electrical connector assembly of FIG. 2;

FIG. 4 is a fragmentary perspective view of the plug of FIG. 3;

FIG. 5 is a partly exploded perspective view of the plug of FIG. 3;

FIG. 6 is an exploded perspective view of a receptacle of the electrical connector assembly of FIG. 2;

FIG. 7 is a cross-sectional side view of a mating portion of the receptacle of FIG. 6;

FIG. 8 is a cross-sectional side view to illustrate mating of the receptacle of FIG. 6 and the plug of FIG. 3;

FIG. 9 is a front view of the receptacle of FIG. 6;

FIG. 10 is a front view of the plug of FIG. 3;

FIG. 11 is a front view to illustrate a modified receptacle of FIG. 6;

FIG. 12 is a front view to illustrate a modified plug of FIG. 3; and

FIG. 13 is a perspective view to illustrate another modified receptacle of FIG. 6.

**DETAILED DESCRIPTION OF THE PREFERRED EMBODIMENTS**

FIG. 2 illustrates an electrical connector assembly embodying this invention. The electrical connector assembly includes a receptacle 4 with a complementary plug 3.

Referring now to FIGS. 3 to 5, in combination with FIG. 3, the plug 3 includes a plug housing 30 adapted to be connected to a cable 5 at a rear end 32 thereof and having an insulative outer shell 38 and a metal inner shell 37 extending into the outer shell 38, and a plurality of plug terminals 33 mounted in the plug housing 30. The inner shell 37 includes a substantially rectangular supporting portion 371 disposed in the outer shell 38, and a hollow first mating portion 36 defined by a multi-sided first confining wall 36' and projecting from the supporting portion 371 and out of a front end of the outer shell 38. The supporting portion 371 includes a U-shaped base piece 360 having a flat bight portion 363 and two opposite arms 364 which project from two opposite sides of the bight portion 363 in directions substantially perpendicular to the bight portion 363 and which are formed with through-holes 365, and an inverted U-shaped cover piece 35 coupled with the base piece 360 and having a flat bight portion 353 parallel to the bight portion 363 of the base piece 360 and two opposite arms 351 which project from two opposite sides of the bight portion 353 toward the arms 364 of the base piece 360 and which are formed with tongues 352 that respectively and detachably engage the through-holes 365 when the base piece 360 and the cover piece 35 are coupled together. An arc-shaped plate 366 projects from a rear end of the bight portion 363 to support the cable 5. A positioning tape 354 is secured to a rear end of the cover piece 35 adjacent to the arc-shaped plate 366 for winding on the cable 5 and the arc-shaped plate 366 so as to firmly fix the cable 5 on the arc-shaped plate 366. A pair of opposite positioning tongues 362 project inwardly from the first confining wall 36'. A locking opening 369 is formed in the first confining wall 36'.

The plug terminals 33 are mounted on a plug terminal seat 34 which includes a base part 341 formed with a plurality of terminal passageways 344 for receiving the plug terminals 33 and having a contact portion 345 which projects into the

US 6,508,678 B1

3

first mating portion 36, and a positioning block 342 projecting from the base part 341, crossing the terminal passageways 344, and having a plurality of grooves aligned with the passageways 344 to confine the plug terminals 33. A pair of positioning recesses 343 are formed in two opposite sides of the positioning block 342 to engage the positioning tongues 362 when the plug terminal seat 34 is disposed in the inner shell 37. An elastic sleeve 39 is sleeved on a connecting end 51 of the cable 5, and is connected to the plug housing 30 for protecting the cable 5 from being bent.

Referring now to FIGS. 6 and 7, in combination with FIGS. 2 to 5, the receptacle 4 includes a metal receptacle housing 45 adapted to be mounted on a printed circuit board (not shown) and having a substantially U-shaped supporting portion 451' and a second mating portion 453 defined by a multi-sided second confining wall 453' and projecting from a front end of the supporting portion 451', a receptacle terminal seat 41' mounted on the supporting portion 451', and a plurality of receptacle terminals 43 mounted on the receptacle terminal seat 41'. The supporting portion 451' of the receptacle housing 45 has a bight part 452 and two opposite arms 451 projecting from two opposite sides of the bight part 452 in directions substantially perpendicular to the bight part 452. A cover plate 456 projects from a rear end 454 of the supporting portion 451', and has two opposite legs formed with locking recesses 459. A pair of lugs 450 project from one end of each arm 451 of the supporting portion 451' of the receptacle housing 45 for engaging the printed circuit board. A pair of elongated slots 455 are formed in the arms 451, and open at the rear end 454 of the supporting portion 451'. A pair of tongues 460 project outwardly from the arms 451 between the elongated slot 455 and the lugs 450. The bight part 452 of the supporting portion 451' is punched or is stamped to form a main spring arm 457 and a pair of secondary spring arms 458 thereon. The main spring arm 457 has a front end formed with a bent section 457'.

The receptacle terminal seat 41' includes a rectangular positioning body 41 and a base part 42' projecting from a front face 443 of the positioning body 41 and having a contact portion 42 extending into the second mating portion 453 to mate with the contact portion 345 of the base part 341 of the plug terminal seat 34. A plurality of receptacle terminal passageways 446 are formed in the base part 42' for receiving the receptacle terminals 43. The base part 42' has a side wall 445 defining one side of each receptacle terminal passageway 446 and formed with a plurality of openings 447 that are respectively aligned with and spatially communicated with the receptacle terminal passageways 446. A pair of protrusions 448 respectively project from two opposite sides of the positioning body 41 to engage the elongated slots 455 in the arms 451 of the supporting portion 451' when the assembly of the receptacle terminal seat 41 and the receptacle terminals 43 is disposed in the receptacle housing 45. Each receptacle terminal 43 has a spring arm 436 disposed in one of the receptacle terminal passageways 446 and having a front end formed with a bent portion 437 that protrudes through the respective opening 447 in the side wall 445 of the base part 42', and an L-shaped solder tail 439 extending from the spring arm 436 through the positioning body 41 and adapted to be soldered to the printed circuit board (not shown). The legs of the cover plate 456 are bent at an angle of 90° to permit the locking recesses 459 to engage the tongues 460 at the arms 451 of the supporting portion 451' after the assembly of the receptacle terminal seat 41 and the receptacle terminals 43 is disposed in the receptacle housing 45.

Referring now to FIGS. 9 and 10, in combination with FIGS. 3 and 6, each of the first and second confining walls

4

36', 453' has opposite first and second sides 371, 372' (481, 482), a pair of opposite third sides 373 (483) respectively connected to two opposite ends of the first side 371 (481), a pair of fourth sides 374 (484) respectively connected to two opposite ends of the second sides 372 (482), and a pair of fifth sides 375 (485) each extending between and interconnecting one of the third sides 373 (483) and one of the fourth sides 374 (484). The first side 371 (481) is longer than the second side 372 (482). The width between the third sides 373 (483) is greater than that between the fourth sides 374 (484). The fifth sides 375 (485) are angled away from each other while extending from the fourth sides 374 (484) to the third sides 373 (483). The first and second sides 371, 372 (481, 482) are substantially parallel. The third sides 373 (483) are substantially perpendicular to the first side 371 (481). The fourth sides 374 (484) extend obliquely and respectively from the opposite ends of the second side 372 (482). The fifth sides 375, (485) are respectively and substantially perpendicular to the third sides 373 (483). The shortest distance (indicated as reference mark H1 shown in FIG. 9 or H1' in FIG. 10) from one of, two opposite ends of each third side 373 (483), that is distal from the first side 371 (481), to a plane defined by the second side 372 (482) is smaller than the distance (indicated as reference mark W1 shown in FIG. 9 or W1' in FIG. 10) from one of the opposite ends of the second side 372 (482), that is adjacent to that third side 373 (483), to a plane defined by that third side 373 (483). The locking opening 369 is formed at the first side 371 of the first confining wall 36'.

Referring now to FIG. 8, in combination with FIGS. 3 and 7, the locking opening 369 engages the bent section 457' of the main spring arm 457 of the bight part 452, and each plug terminal 33 abuts against the bent portion 437 of the respective receptacle terminal 43 when the plug 3 is plugged into the receptacle 4.

FIGS. 11 and 12 respectively illustrate a modified receptacle 4' and a modified plug 3' which are similar to the previous receptacle 4 and the previous plug 3 except that the fourth sides 374' (484') are substantially perpendicular to the second side 372' (482'), that each fifth side 375' (485') is oblique relative to the respective third side 373' (483') and the respective fourth side 374' (484'), and that the shortest distance (indicated as reference mark H2 shown in FIG. 11 or H2' in FIG. 12) from one of two opposite ends of each third side 373' (483'), that is distal from the first side 371' (481') to the plane defined by the second side 372' (482') is greater than the distance (indicated as reference mark W2 shown in FIG. 11 or W2' in FIG. 12) from an adjacent one of the opposite ends of the second side 372' (482') to the plane defined by that third side 373' (483').

FIG. 13 illustrates another modified receptacle 4" which is a combination of the previous receptacle 4 and the previous modified receptacle 4' that are stacked one above the other.

Referring now to FIGS. 3 and 6, the plug terminals 33 include spaced apart two first power terminals 331, a first detecting terminal 335 disposed adjacent and integrally formed with one of the power terminals 331, and two spaced apart data terminals 333, 334. The receptacle terminals 43 are spaced apart from each other, and include two second power terminals 431, a second detecting terminal 435 disposed adjacent to one of the power terminals 431, and two data terminals 433, 434. The second detecting terminal 435 is electrically connected to the adjacent one of the second power terminals 431 via the interconnected one of the first power terminals 331 and the first detecting terminal 335 when the plug 3 and the receptacle 4 are coupled together,

thereby permitting the printed circuit board to distinguish the type of plug that is connected thereto.

With the invention thus explained, it is apparent that various modifications and variations can be made without departing from the spirit of the present invention. It is therefore intended that the invention be limited only as recited in the appended claims.

I claim:

1. An electrical connector assembly, comprising:

a plug that includes a plug housing having a first mating portion, and a plurality of plug terminals mounted inside said plug housing, said first mating portion being defined by a multi-sided first confining wall; and

a receptacle that includes a receptacle housing having a second mating portion to mate with said first mating portion, and a plurality of receptacle terminals mounted inside said receptacle housing, said second mating portion being defined by a multi-sided second confining wall,

each of said first and second confining walls having opposite first and second sides, a pair of opposite third sides respectively connected to two opposite ends of said first side, a pair of fourth sides respectively connected to two opposite ends of said second side, and a pair of fifth sides each extending between and interconnecting one of said third sides and one of said fourth sides, said first side being longer than said second side, said first and second sides being longer than each of said third sides, the width between said third sides being greater than that between said fourth sides, said fifth sides being angled away from each other while extending from said fourth sides to said third sides;

wherein said first and second sides are substantially parallel, and said third sides are substantially perpendicular to said first side; and

wherein said fourth sides extend obliquely from said second side.

2. The electrical connector assembly of claim 1, wherein said fifth sides are respectively and substantially perpendicular to said third sides.

3. The electrical connector assembly of claim 2, wherein each of said third sides has two opposite ends, the shortest distance from one of said opposite ends of said third side, that is distal from said first side, to a plane defined by said second side being smaller than that from one of said opposite ends of said second side, that is adjacent to said one of said opposite ends of said third side, to a plane defined by said third side.

4. The electrical connector assembly of claim 1, wherein said plug terminals include a first power terminal and a first detecting terminal which is electrically connected to said first power terminal, and said receptacle terminals include a second power terminal and a second detecting terminal which is spaced apart from said second power terminal and which is electrically connected to said second power terminal via said first power terminal and said first detecting terminal when said first and second mating portions are coupled together.

5. The electrical connector assembly of claim 4, wherein said first power terminal and said first detecting terminal are integrally formed and are punched from a metal plate.

\* \* \* \* \*