

**IN THE UNITED STATES DISTRICT COURT
FOR THE DISTRICT OF DELAWARE**

HERA WIRELESS S.A. and SISVEL UK
LIMITED,

Plaintiffs,

v.

LENOVO HOLDING COMPANY, INC.;
and LENOVO (UNITED STATES), INC.,

Defendants.

Civil Action No. 1:17-cv-1088-RGA

JURY TRIAL DEMANDED

AMENDED COMPLAINT FOR PATENT INFRINGEMENT

Plaintiffs Hera Wireless S.A. (“Hera Wireless”) and Sisvel UK Limited (Sisvel UK”) (collectively “Plaintiffs”), for their Complaint against Defendants Lenovo Holding Company, Inc. (“LHCI”), and Lenovo (United States), Inc. (“Lenovo U.S.A.”) (collectively “Defendants” or “Lenovo”), allege the following:

NATURE OF THE ACTION

1. This is an action for patent infringement arising under the Patent Laws of the United States, 35 U.S.C. § 1 *et seq.*

THE PARTIES

2. Hera Wireless is a corporation organized under the laws of Luxembourg with a place of business at 50Val Fleuri, L-1526, Luxembourg.

3. Sisvel UK is a limited liability company organized under the laws of the United Kingdom with a place of business at 1 Kingdom Street, London, United Kingdom, W2 6BD.

4. Upon information and belief, LHCI is a corporation organized and existing under the laws of the State of Delaware, with a place of business at 1009 Think Place, Morrisville, North

Carolina 27560, and can be served through its registered agent, The Corporation Trust Company, Corporation Trust Center 1209 Orange Street, Wilmington, Delaware 19801. Upon information and belief, LHCI sells and offers to sell products and services throughout the United States, including in this judicial district, and introduces products and services that into the stream of commerce and that incorporate infringing technology knowing that they would be sold in this judicial district and elsewhere in the United States.

5. Upon information and belief, Lenovo U.S.A. is a corporation organized and existing under the laws of the State of Delaware, with a place of business at 1009 Think Place, Morrisville, North Carolina 27560, and can be served through its registered agent, The Corporation Trust Company, Corporation Trust Center 1209 Orange Street, Wilmington, Delaware 19801. Upon information and belief, Lenovo U.S.A. sells and offers to sell products and services throughout the United States, including in this judicial district, and introduces products and services that into the stream of commerce and that incorporate infringing technology knowing that they would be sold in this judicial district and elsewhere in the United States.

JURISDICTION AND VENUE

6. This is an action for patent infringement arising under the Patent Laws of the United States, Title 35 of the United States Code.

7. This Court has subject matter jurisdiction under 28 U.S.C. §§ 1331 and 1338(a).

8. Venue is proper in this judicial district under 28 U.S.C. §1400(b). On information and belief, Defendants are incorporated in the State of Delaware.

9. On information and belief, Defendants are subject to this Court's general and specific personal jurisdiction because Defendants have sufficient minimum contacts within the State of Delaware and this District, pursuant to due process and/or the Del. Code. Ann. Tit. 3,

§ 3104, because Defendants purposefully availed themselves of the privileges of conducting business in the State of Delaware and in this District, because Defendants regularly conduct and solicit business within the State of Delaware and within this District, and because Plaintiffs' causes of action arise directly from each of Defendants' business contacts and other activities in the State of Delaware and this District. Further, this Court has personal jurisdiction over Defendants because Defendants are incorporated in Delaware and have purposely availed themselves of the privileges and benefits of the laws of the State of Delaware.

BACKGROUND

10. This action involves nine patents, described in detail in the counts below (collectively, the "Asserted Patents"), that claim Wi-Fi technologies developed in the early 2000s in Japan by Sanyo Electric Co., Ltd. ("Sanyo") scientists Yoshiharu Doi, Takeo Miyata, Tadayoshi Ito, and Seigo Nakao, the latter of whom is a named inventor on over 800 U.S. patents and patent applications.

11. Panasonic Corporation ("Panasonic") subsequently purchased Sanyo in stages, with the final 20% being purchased on December 21, 2010. Sanyo thus became a wholly owned subsidiary of Panasonic.

12. At the time of the acquisition, both Sanyo and Panasonic were operating entities that offered products in the fields of consumer electronics and business applications. Indeed, both companies are household names.

13. Sanyo was actively involved with standards-development organizations that developed industry standards relevant to the company's product portfolio, including the company's Wi-Fi enabled consumer electronic goods.

14. The Institute of Electrical and Electronics Engineers (IEEE) is a leading standards-development organization for the development of industrial standards (having developed over 900 active industry technical standards) in a broad range of disciplines, including electric power and energy, telecommunications, consumer electronics, biomedical technology and healthcare-information technology, information assurance, transportation, aerospace, and nanotechnology.

15. Today, IEEE is the world's largest association of technical professionals with more than 420,000 members in over 160 countries around the world. Its objectives are the educational and technical advancement of electrical and electronic engineering, telecommunications, computer engineering, and allied disciplines.

16. The IEEE 802.11 standards, created by the IEEE, are a set of media access control (MAC) and physical layer (PHY) specifications for implementing wireless local area network (WLAN) computer communication in the 900 MHz and 2.4, 3.6, 5, and 60 GHz frequency bands.

17. The IEEE 802.11 standards are created and maintained by the IEEE LAN/MAN Standards Committee (IEEE 802).

18. The base version of IEEE 802.11 was released in 1997, and has had subsequent amendments. The standard and amendments provide the basis for wireless network products using the Wi-Fi brand.

19. The inventions claimed in the Asserted Patents relate to radio apparatuses configured to perform improved multiple-input multiple-output (“MIMO”) wireless local area network communications, and the claimed technologies have become industry standard for Wi-Fi products. Radio apparatuses certified as compliant with IEEE Standard 802.11n-2009

necessarily meet the claim limitations of the Asserted Patents. Inventors Yoshiharu Doi and Siego Nakao participated in the standards-setting organization leading to the development and adoption of the 802.11n-2009 standard.

20. IEEE 802.11n-2009, commonly shortened to 802.11n, is a wireless-networking standard that uses multiple antennas to increase data rates. It is an amendment to the IEEE 802.11-2007 wireless-networking standard, and its purpose is to improve network throughput over the two previous standards—802.11a and 802.11g—with a significant increase in the maximum net data rate from 54 Mbit/s to 600 Mbit/s (slightly higher gross bit rate, including, for example, error-correction codes, and slightly lower maximum throughput) with the use of four spatial streams at a channel width of 40 MHz.

21. The standard has enabled increased efficiency, as evidenced by the fact that MIMO is now found in most high-end, Wi-Fi-enabled consumer electronics. The majority of products adopting this technological advance are advertised as being compliant with the standard, and companies regularly list their product as compliant with this particular standard on trade group web sites (such as the Wi-Fi Alliance website).

22. In March 2011, Plaintiff Hera Wireless obtained licensing rights to the Asserted Patents.

23. In September 2012, Plaintiff Hera Wireless partnered with Plaintiff Sisvel UK, part of the Sisvel Group (“Sisvel”), to license the Asserted Patents on an exclusive basis industry wide. Sisvel has since been licensing the Asserted Patents on behalf of Hera Wireless across Europe and Asia, with companies taking a license based on the value of the patents without need for litigation.

24. In June 2014, Hera Wireless acquired the Asserted Patents and others from Sanyo via a Patent Assignment Agreement.

25. In early 2016, Sisvel initiated licensing activities in North America via its U.S. subsidiary, Sisvel US Inc.

26. Founded in Italy in 1982, Sisvel is a world leader in fostering innovation and managing intellectual property. Sisvel works with its partners offering a comprehensive approach to patent licensing: from issuing initial calls for essential patents; facilitating discussions among stakeholders; developing multiparty license agreements; executing and administering licenses; to collecting and distributing royalties. At the same time, Sisvel actively promotes a culture of respect and understanding of the intellectual property and innovation ecosystem through, for example, its regular presence at the key consumer electronics trade fairs and intellectual property events, participation in policy discussions and conferences, as well as open dialogues with a number of government bodies, standard-setting organizations and industry associations.

27. As of the date this complaint was filed, over sixty companies have licensed one or more of the industry-standard Asserted Patents, along with other Sisvel patents related to Wi-Fi technology.

COUNT I – INFRINGEMENT OF U.S. PATENT NO. 7,962,103

28. The allegations set forth in the foregoing paragraphs 1 through 27 are incorporated into this First Claim for Relief.

29. On June 14, 2011, U.S. Patent No. 7,962,103 (“the ’103 patent”), entitled “Radio Apparatus, and Method and Program for Controlling Spatial Path,” was duly and legally issued by the United States Patent and Trademark Office. A true and correct copy of the ’103 patent is attached as Exhibit 1.

30. Plaintiff Hera Wireless is the assignee and owner of the right, title and interest in and to the '103 patent. Plaintiffs have the right to assert all causes of action arising under said patent and the right to any remedies for infringement thereof.

31. Upon information and belief, Defendants have and continue to directly infringe at least claims 1 and 4 of the '103 patent by making, using, selling, importing and/or providing and causing to be used products incorporating radio transmitting apparatuses compliant with IEEE Standard 802.11n-2009 (the "Accused Instrumentalities"). For example, Defendants affirmatively represent at the following URL that they make and sell products compliant with IEEE Standard 802.11n-2009: <http://www3.lenovo.com/us/en/tablets/android-tablets/yoga-tab-3-series/Lenovo-YT3-850F/p/ZA090094US#tab-reviews>. However, the Accused Instrumentalities are understood to include any and all products that Defendants have or continues to make, use, sell, import and/or provide and cause to be used that are compliant with IEEE Standard 802.11n-2009.

32. In particular, claim 1 of the '103 patent recites a radio apparatus capable of communicating with another radio apparatus by forming a plurality of spatial paths therebetween, the radio apparatus comprising: an adaptive array unit capable of performing adaptive array processing on signals corresponding to a plurality of antennas, respectively; a storage unit which stores beforehand a value indicating possible multiplicity associated with the number of spatial paths formable by said adaptive array unit; and a control unit which controls a processing of transmitting the value indicating possible multiplicity to the another radio apparatus at a predetermined timing.

33. On information and belief, the Accused Instrumentalities infringe claim 1 of the '103 patent because they comply with IEEE Standard 802.11n-2009, which requires a radio

apparatus capable of communicating with another radio apparatus by forming a plurality of spatial paths therebetween (the block diagram below illustrates exemplary elements of the Accused Instrumentalities that function to generate a plurality of spatial paths according to the standard):

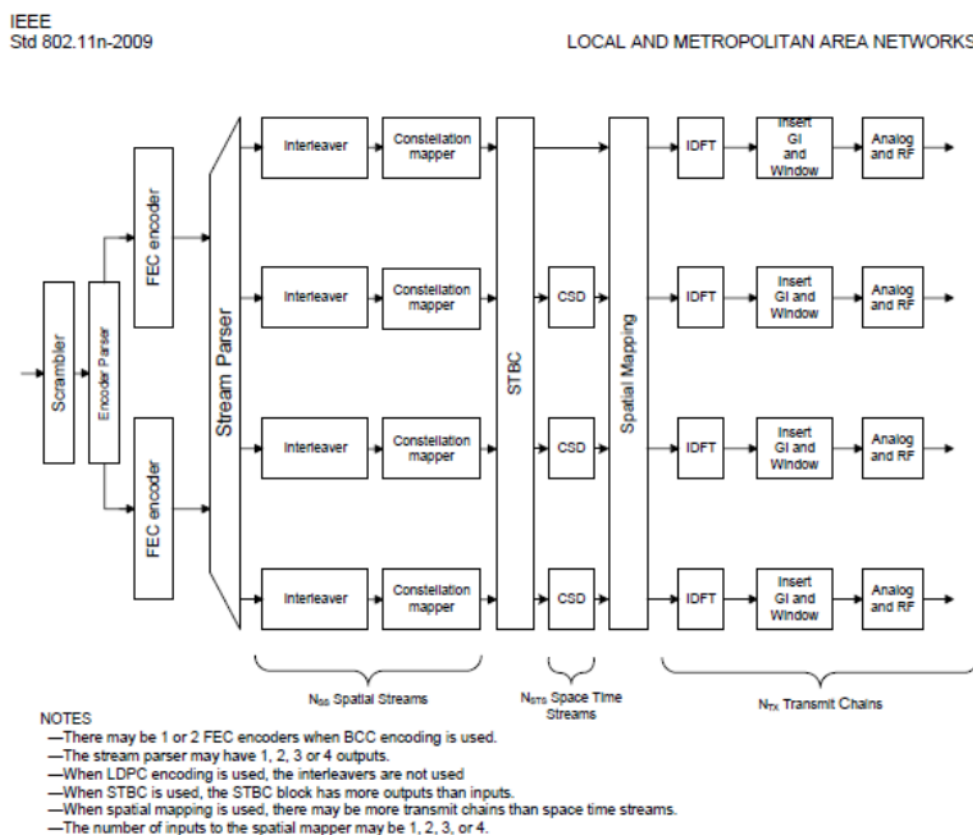

Figure 20-3—Transmitter block diagram 2

the radio apparatus comprising: an adaptive array unit capable of performing adaptive array processing on signals corresponding to the plurality of antennas, respectively:

The adaptive array unit comprises a transmitter with the following functionality:

IEEE Std. 802.11n-2009

20.3.11.10.1 Spatial mapping

The transmitter may choose to rotate and/or scale the constellation mapper output vector (or the space-time block coder output, if applicable). This rotation and/or scaling is useful in the following cases:

- When there are more transmit chains than space-time streams,
- As part of (an optional) sounding packet
- As part of (an optional) calibration procedure
- When the packet is transmitted using one of the (optional) beamforming techniques

a storage unit which stores beforehand a value indicating possible multiplicity associated with the number of spatial paths formable by said adaptive array unit:

IEEE Std. 802.11n-2009

7.3.2.56.4 Supported MCS Set field

The Supported MCS Set field of the HT Capabilities element indicates which MCSs a STA supports.

An MCS is identified by an MCS index, which is represented by an integer in the range 0 to 76. The interpretation of the MCS index (i.e., the mapping from MCS to data rate) is PHY dependent. For the HT PHY, see 20.6.

The structure of the MCS Set field is defined in Figure 7-95o20.

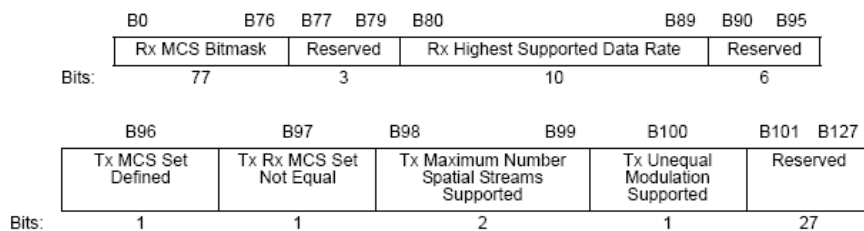

Figure 7-95o20—Supported MCS Set field

Section 20.6 defines the RX MCS Bitmask, and in particular Table 20.29 to Table 20.43 connect each index to a maximum number of spatial streams (N_{ss}). For example:

The rate-dependent parameters for optional 20 MHz, $N_{SS} = 3$ MCSs with $N_{ES} = 1$ and EQM of the spatial streams shall be as shown in Table 20-31.

Table 20-31—MCS parameters for optional 20 MHz, $N_{SS} = 3$, $N_{ES} = 1$, EQM

MCS Index	Modulation	R	$N_{BPSCS}(i_{SS})$	N_{SD}	N_{SP}	N_{CBPS}	N_{DBPS}	Data rate (Mb/s)	
								800 ns GI	400 ns GI
16	BPSK	1/2	1	52	4	156	78	19.5	21.7
17	QPSK	1/2	2	52	4	312	156	39.0	43.3
18	QPSK	3/4	2	52	4	312	234	58.5	65.0
19	16-QAM	1/2	4	52	4	624	312	78.0	86.7
20	16-QAM	3/4	4	52	4	624	468	117.0	130.0
21	64-QAM	2/3	6	52	4	936	624	156.0	173.3
22	64-QAM	3/4	6	52	4	936	702	175.5	195.0
23	64-QAM	5/6	6	52	4	936	780	195.0	216.7

and a control unit which controls a processing of transmitting the value indicating possible multiplicity to the another radio apparatus at a predetermined timing:

As shown above, the MCS Set field, including the Rx MCS set, is part of the HT Capabilities element. The HT Capabilities element, including the Rx MCS set, is transmitted to another radio apparatus, as set forth below:

7.3.2.56.1 HT Capabilities element structure

An HT STA declares that it is an HT STA by transmitting the HT Capabilities element. The HT Capabilities element contains a number of fields that are used to advertise optional HT capabilities of an HT STA. The HT Capabilities element is present in Beacon, Association Request, Association Response, Reassociation Request, Reassociation Response, Probe Request, and Probe Response frames. The HT Capabilities element is defined in Figure 7-95o17.

The standard prescribes that the Beacon is transmitted at a predetermined timing, as set forth below:

11.1.1.1 TSF for infrastructure networks

In an infrastructure BSS, the AP shall be the timing master for the TSF. The AP shall initialize its TSF timer independently of any simultaneously started APs in an effort to minimize the synchronization of the TSF timers of multiple APs. The AP shall periodically transmit special frames called *Beacon frames* that contain a copy of its TSF timer to synchronize the TSF timers of other STAs in a BSS. A receiving STA shall always accept the timing information in Beacon frames sent from the AP servicing its BSS. If a STA's TSF timer is different from the timestamp in the received Beacon frame, the receiving STA shall set its local TSF timer to the received timestamp value.

Beacon frames shall be generated for transmission by the AP once every dot11BeaconPeriod TUs.

11.1.2 Maintaining synchronization

Each STA shall maintain a TSF timer with modulus 2^{64} counting in increments of microseconds. STAs expect to receive Beacon frames at a nominal rate. The interval between Beacon frames is defined by the dot11BeaconPeriod parameter of the STA. A STA sending a Beacon frame shall set the value of the Beacon frame's timestamp so that it equals the value of the STA's TSF timer at the time that the data symbol containing the first bit of the timestamp is transmitted to the PHY plus the transmitting STA's delays through its local PHY from the MAC-PHY interface to its interface with the WM [e.g., antenna, light-emitting diode (LED) emission surface].

34. Claim 4 of the '103 patent recites a radio apparatus capable of communicating with another radio apparatus by forming a plurality of spatial paths therebetween, the radio apparatus comprising: a plurality of antennas constituting an array antenna; an adaptive array unit capable of performing adaptive array processing on signals corresponding to the plurality of antennas, respectively; a storage unit which stores beforehand a value indicating possible multiplicity associated with the number of spatial paths formable by said adaptive array unit; and a control unit which controls a processing of transmitting the value indicating possible multiplicity to the another radio apparatus at a predetermined timing.

35. On information and belief, the Accused Instrumentalities infringe claim 4 of the '103 patent because they comply with IEEE Standard 802.11n-2009, which requires a radio apparatus capable of communicating with another radio apparatus by forming a plurality of spatial paths therebetween (the block diagram below illustrates exemplary elements of the Accused Instrumentalities that function to generate a plurality of spatial paths according to the standard):

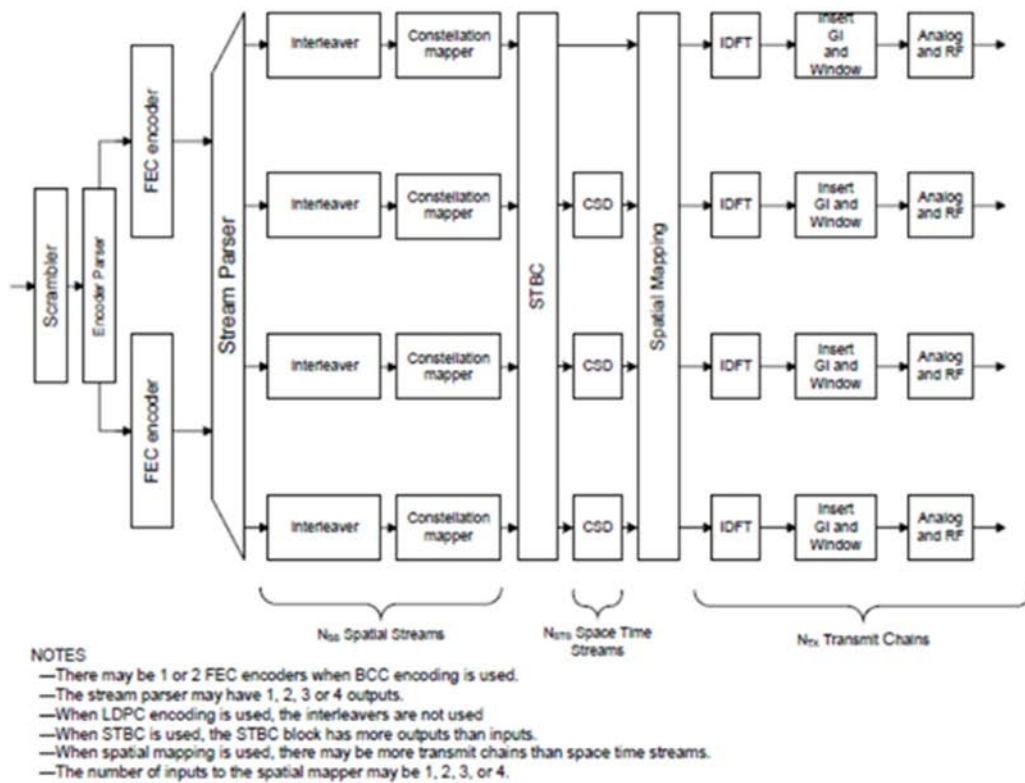

Figure 20-3—Transmitter block diagram 2

the radio apparatus comprising: a plurality of antennas constituting an array antenna:

IEEE Std. 802.11n-2009

20.3.9 HT preamble

20.3.9.1 Introduction

The HT preambles are defined in HT-mixed format and in HT-greenfield format to carry the required information to operate in a system with multiple transmit and multiple receive antennas.

See also:

3.249 spatial stream: One of several streams of bits or modulation symbols that may be transmitted over multiple spatial dimensions that are created by the use of multiple antennas at both ends of a communications link.

an adaptive array unit capable of performing adaptive array processing on signals corresponding to the plurality of antennas, respectively:

The adaptive array unit comprises a transmitter with the following functionality:

IEEE Std. 802.11n-2009

20.3.11.10.1 Spatial mapping

The transmitter may choose to rotate and/or scale the constellation mapper output vector (or the space-time block coder output, if applicable). This rotation and/or scaling is useful in the following cases:

- When there are more transmit chains than space-time streams,
- As part of (an optional) sounding packet
- As part of (an optional) calibration procedure
- When the packet is transmitted using one of the (optional) beamforming techniques

a storage unit which stores beforehand a value indicating possible multiplicity associated with the number of spatial paths formable by said adaptive array unit:

IEEE Std. 802.11n-2009

7.3.2.56.4 Supported MCS Set field

The Supported MCS Set field of the HT Capabilities element indicates which MCSs a STA supports.

An MCS is identified by an MCS index, which is represented by an integer in the range 0 to 76. The interpretation of the MCS index (i.e., the mapping from MCS to data rate) is PHY dependent. For the HT PHY, see 20.6.

The structure of the MCS Set field is defined in Figure 7-95o20.

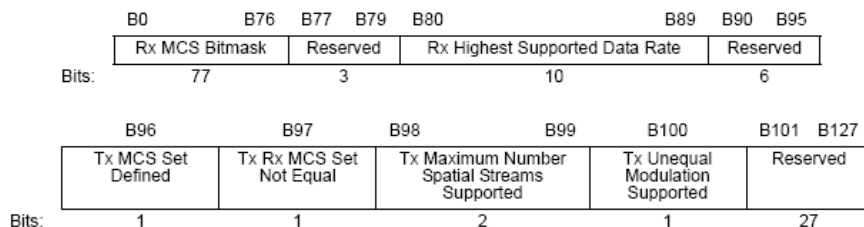

Figure 7-95o20—Supported MCS Set field

Section 20.6 defines the RX MCS Bitmask, and in particular Table 20.29 to Table 20.43 connect each index to a maximum number of spatial streams (Nss). For example:

The rate-dependent parameters for optional 20 MHz, $N_{SS} = 3$ MCSs with $N_{ES} = 1$ and EQM of the spatial streams shall be as shown in Table 20-31.

Table 20-31—MCS parameters for optional 20 MHz, $N_{SS} = 3$, $N_{ES} = 1$, EQM

MCS Index	Modulation	R	$N_{BPSCS}(i_{SS})$	N_{SD}	N_{SP}	N_{CBPS}	N_{DBPS}	Data rate (Mb/s)	
								800 ns GI	400 ns GI
16	BPSK	1/2	1	52	4	156	78	19.5	21.7
17	QPSK	1/2	2	52	4	312	156	39.0	43.3
18	QPSK	3/4	2	52	4	312	234	58.5	65.0
19	16-QAM	1/2	4	52	4	624	312	78.0	86.7
20	16-QAM	3/4	4	52	4	624	468	117.0	130.0
21	64-QAM	2/3	6	52	4	936	624	156.0	173.3
22	64-QAM	3/4	6	52	4	936	702	175.5	195.0
23	64-QAM	5/6	6	52	4	936	780	195.0	216.7

and a control unit which controls a processing of transmitting the value indicating possible multiplicity to the another radio apparatus at a predetermined timing:

As shown above, the MCS Set field, including the Rx MCS set, is part of the HT Capabilities element. The HT Capabilities element, including the Rx MCS set, is transmitted to another radio apparatus, as set forth below:

7.3.2.56.1 HT Capabilities element structure

An HT STA declares that it is an HT STA by transmitting the HT Capabilities element. The HT Capabilities element contains a number of fields that are used to advertise optional HT capabilities of an HT STA. The HT Capabilities element is present in Beacon, Association Request, Association Response, Reassociation Request, Reassociation Response, Probe Request, and Probe Response frames. The HT Capabilities element is defined in Figure 7-95o17.

The standard prescribes that the Beacon is transmitted at a predetermined timing, as set forth below:

11.1.1.1 TSF for infrastructure networks

In an infrastructure BSS, the AP shall be the timing master for the TSF. The AP shall initialize its TSF timer independently of any simultaneously started APs in an effort to minimize the synchronization of the TSF timers of multiple APs. The AP shall periodically transmit special frames called *Beacon frames* that contain a copy of its TSF timer to synchronize the TSF timers of other STAs in a BSS. A receiving STA shall always accept the timing information in Beacon frames sent from the AP servicing its BSS. If a STA's TSF timer is different from the timestamp in the received Beacon frame, the receiving STA shall set its local TSF timer to the received timestamp value.

Beacon frames shall be generated for transmission by the AP once every dot11BeaconPeriod TUs.

11.1.2 Maintaining synchronization

Each STA shall maintain a TSF timer with modulus 2^{64} counting in increments of microseconds. STAs expect to receive Beacon frames at a nominal rate. The interval between Beacon frames is defined by the dot11BeaconPeriod parameter of the STA. A STA sending a Beacon frame shall set the value of the Beacon frame's timestamp so that it equals the value of the STA's TSF timer at the time that the data symbol containing the first bit of the timestamp is transmitted to the PHY plus the transmitting STA's delays through its local PHY from the MAC-PHY interface to its interface with the WM [e.g., antenna, light-emitting diode (LED) emission surface].

36. On information and belief, these Accused Instrumentalities are used, marketed, provided to, and/or used by or for each of Defendants' partners, clients, customers and end users across the country and in this District.

37. Defendants were made aware of the '103 patent and their infringement thereof at least as early as March 31, 2016, when Mr. Chuck Hausmann, Esq., on behalf of Plaintiffs, sent a letter to Ms. Kathryn Tsigotis, Director of Licensing for Lenovo USA, disclosing the '103 patent and other of Plaintiffs' patents and alleging that Defendants' products infringed the '103 patent, among others.

38. Upon information and belief, since at least the time Defendants received notice, Defendants have induced and continue to induce others to infringe at least one claim of the '103 patent under 35 U.S.C. § 271(b) by, among other things, and with specific intent or willful blindness, actively aiding and abetting others to infringe, including but not limited to Defendants' partners, clients, customers, and end users, whose use of the Accused Instrumentalities constitutes direct infringement of at least one claim of the '103 patent.

39. In particular, Defendants' actions that aid and abet others such as its partners, customers, clients, and end users to infringe include advertising and distributing the Accused Instrumentalities and providing instruction materials, training, and services regarding the Accused Instrumentalities. On information and belief, Defendants have engaged in such actions with specific intent to cause infringement or with willful blindness to the resulting infringement

because Defendants have had actual knowledge of the '103 patent and knowledge that its acts were inducing infringement of the '103 patent since at least March 31, 2016.

40. Upon information and belief, Defendants are liable as contributory infringers of the '103 patent under 35 U.S.C. § 271(c) by offering to sell, selling and importing into the United States components to be especially made or adapted for use in an infringement of the '103 patent. The Accused Instrumentalities are a material component for use in practicing the '103 patent and are specifically made and are not a staple article of commerce suitable for substantial non-infringing use.

41. Since March 31, 2016, Defendants' infringement has been willful.

42. Plaintiffs have been harmed by Defendants' infringing activities.

COUNT II – INFRINGEMENT OF U.S. PATENT NO. 8,412,115

43. The allegations set forth in the foregoing paragraphs 1 through 42 are incorporated into this Second Claim for Relief.

44. On April 2, 2013, U.S. Patent No. 8,412,115 ("the '115 patent"), entitled "Radio Apparatus, and Method and Program for Controlling Spatial Path," was duly and legally issued by the United States Patent and Trademark Office. A true and correct copy of the '115 patent is attached as Exhibit 2.

45. Plaintiff Hera Wireless is the assignee and owner of the right, title and interest in and to the '115 patent. Plaintiffs have the right to assert all causes of action arising under said patent and the right to any remedies for infringement thereof.

46. Upon information and belief, Defendants have and continue to directly infringe at least claims 1 and 4 of the '115 patent by making, using, selling, importing and/or providing and causing to be used the Accused Instrumentalities, as defined above.

47. In particular, claim 1 of the '115 patent recites a radio apparatus capable of communicating with another radio apparatus by forming a plurality of spatial paths therebetween, the radio apparatus comprising: a communication unit configured to communicate using an antenna; a storage unit which stores beforehand a value indicating possible multiplicity associated with the number of spatial paths formable by said communication unit; and a control unit which controls a processing of transmitting the value indicating possible multiplicity to the another radio apparatus at a predetermined timing.

48. On information and belief, the Accused Instrumentalities infringe claim 1 of the '115 patent because they comply with IEEE Standard 802.11n-2009, which requires a radio apparatus capable of communicating with another radio apparatus (the block diagram below illustrates exemplary elements of the Accused Instrumentalities that function to generate a plurality of spatial paths according to the standard):

IEEE
Std 802.11n-2009

LOCAL AND METROPOLITAN AREA NETWORKS

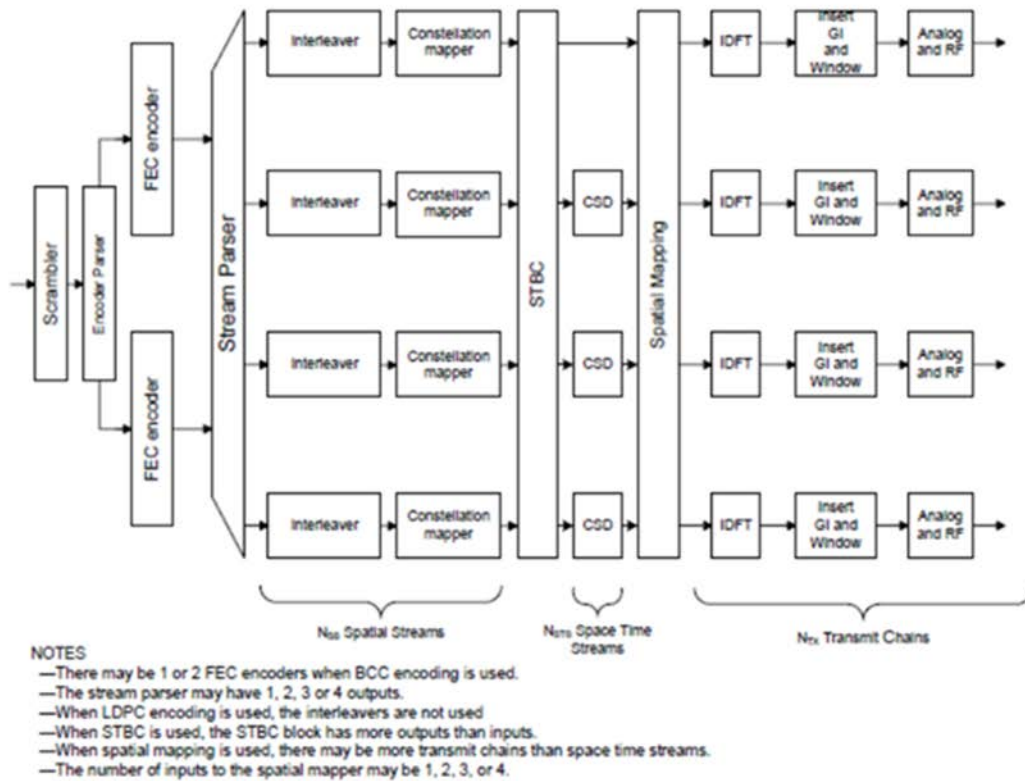

Figure 20-3—Transmitter block diagram 2

the radio apparatus comprising: a communication unit configured to communicate using an antenna:

IEEE Std. 802.11n-2009

20.3.9 HT preamble

20.3.9.1 Introduction

The HT preambles are defined in HT-mixed format and in HT-greenfield format to carry the required information to operate in a system with multiple transmit and multiple receive antennas.

See also:

3.249 spatial stream: One of several streams of bits or modulation symbols that may be transmitted over multiple spatial dimensions that are created by the use of multiple antennas at both ends of a communications link.

a storage unit which stores beforehand a value indicating possible multiplicity associated with the number of spatial paths formable by said communication unit:

IEEE Std. 802.11n-2009

7.3.2.56.4 Supported MCS Set field

The Supported MCS Set field of the HT Capabilities element indicates which MCSs a STA supports.

An MCS is identified by an MCS index, which is represented by an integer in the range 0 to 76. The interpretation of the MCS index (i.e., the mapping from MCS to data rate) is PHY dependent. For the HT PHY, see 20.6.

The structure of the MCS Set field is defined in Figure 7-95o20.

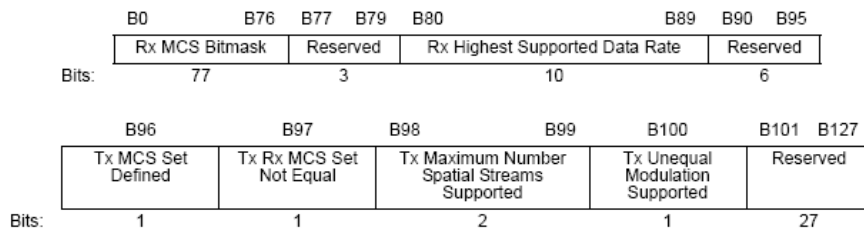

Figure 7-95o20—Supported MCS Set field

Section 20.6 defines the RX MCS Bitmask, and in particular Table 20.29 to Table 20.43 connect each index to a maximum number of spatial streams (N_{SS}). For example:

The rate-dependent parameters for optional 20 MHz, $N_{SS} = 3$ MCSs with $N_{ES} = 1$ and EQM of the spatial streams shall be as shown in Table 20-31.

Table 20-31—MCS parameters for optional 20 MHz, $N_{SS} = 3$, $N_{ES} = 1$, EQM

MCS Index	Modulation	R	$N_{BPSCS}(f_{SS})$	N_{SD}	N_{SP}	N_{CBPS}	N_{DBPS}	Data rate (Mb/s)	
								800 ns GI	400 ns GI
16	BPSK	1/2	1	52	4	156	78	19.5	21.7
17	QPSK	1/2	2	52	4	312	156	39.0	43.3
18	QPSK	3/4	2	52	4	312	234	58.5	65.0
19	16-QAM	1/2	4	52	4	624	312	78.0	86.7
20	16-QAM	3/4	4	52	4	624	468	117.0	130.0
21	64-QAM	2/3	6	52	4	936	624	156.0	173.3
22	64-QAM	3/4	6	52	4	936	702	175.5	195.0
23	64-QAM	5/6	6	52	4	936	780	195.0	216.7

and a control unit which controls a processing of transmitting the value indicating possible multiplicity to the another radio apparatus at a predetermined timing:

As shown above, the MCS Set field, including the Rx MCS set, is part of the HT Capabilities element. The HT Capabilities element, including the Rx MCS set, is transmitted to another radio apparatus, as set forth below:

7.3.2.56.1 HT Capabilities element structure

An HT STA declares that it is an HT STA by transmitting the HT Capabilities element. The HT Capabilities element contains a number of fields that are used to advertise optional HT capabilities of an HT STA. The HT Capabilities element is present in Beacon, Association Request, Association Response, Reassociation Request, Reassociation Response, Probe Request, and Probe Response frames. The HT Capabilities element is defined in Figure 7-95o17.

The standard prescribes that the Beacon is transmitted at a predetermined timing, as set forth below:

11.1.1.1 TSF for infrastructure networks

In an infrastructure BSS, the AP shall be the timing master for the TSF. The AP shall initialize its TSF timer independently of any simultaneously started APs in an effort to minimize the synchronization of the TSF timers of multiple APs. The AP shall periodically transmit special frames called *Beacon frames* that contain a copy of its TSF timer to synchronize the TSF timers of other STAs in a BSS. A receiving STA shall always accept the timing information in Beacon frames sent from the AP servicing its BSS. If a STA's TSF timer is different from the timestamp in the received Beacon frame, the receiving STA shall set its local TSF timer to the received timestamp value.

Beacon frames shall be generated for transmission by the AP once every dot11BeaconPeriod TUs.

11.1.2 Maintaining synchronization

Each STA shall maintain a TSF timer with modulus 2^{64} counting in increments of microseconds. STAs expect to receive Beacon frames at a nominal rate. The interval between Beacon frames is defined by the dot11BeaconPeriod parameter of the STA. A STA sending a Beacon frame shall set the value of the Beacon frame's timestamp so that it equals the value of the STA's TSF timer at the time that the data symbol containing the first bit of the timestamp is transmitted to the PHY plus the transmitting STA's delays through its local PHY from the MAC-PHY interface to its interface with the WM [e.g., antenna, light-emitting diode (LED) emission surface].

49. Claim 4 of the '115 patent recites a radio apparatus capable of communicating with another radio apparatus, the radio apparatus comprising: an antenna; a communication unit configured to communicate using an antenna; a storage unit which stores beforehand a value indicating possible multiplicity associated with the number of spatial paths formable by said communication unit; and a control unit which controls a processing of transmitting the value indicating possible multiplicity to the another radio apparatus at a predetermined timing.

50. On information and belief, the Accused Instrumentalities infringe claim 4 of the '115 patent because they comply with IEEE Standard 802.11n-2009, which requires a radio apparatus capable of communicating with another radio apparatus (the block diagram below illustrates exemplary elements of the Accused Instrumentalities that function to generate a plurality of spatial paths according to the standard):

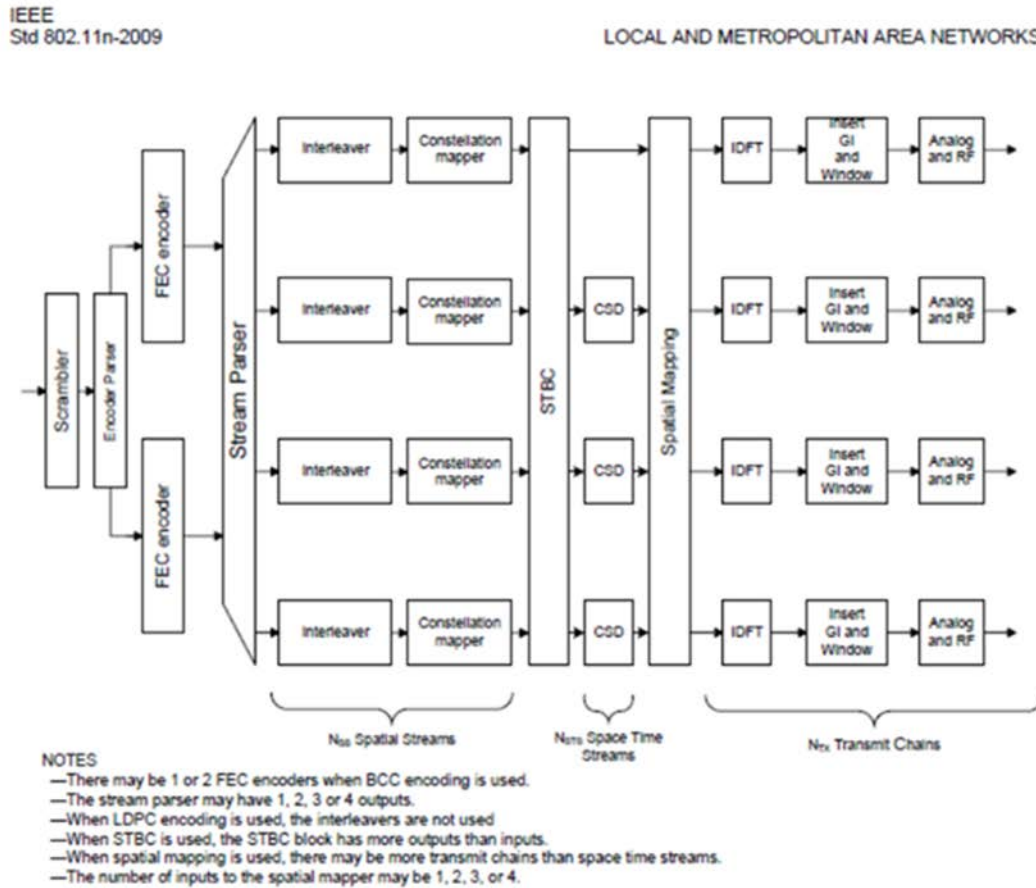

Figure 20-3—Transmitter block diagram 2

the radio apparatus comprising: an antenna; a communication unit configured to communicate using an antenna:

IEEE Std. 802.11n-2009

20.3.9 HT preamble

20.3.9.1 Introduction

The HT preambles are defined in HT-mixed format and in HT-greenfield format to carry the required information to operate in a system with multiple transmit and multiple receive antennas.

See also:

3.249 spatial stream: One of several streams of bits or modulation symbols that may be transmitted over multiple spatial dimensions that are created by the use of multiple antennas at both ends of a communications link.

a storage unit which stores beforehand a value indicating possible multiplicity associated with the number of spatial paths formable by said adaptive array unit:

IEEE Std. 802.11n-2009

7.3.2.56.4 Supported MCS Set field

The Supported MCS Set field of the HT Capabilities element indicates which MCSs a STA supports.

An MCS is identified by an MCS index, which is represented by an integer in the range 0 to 76. The interpretation of the MCS index (i.e., the mapping from MCS to data rate) is PHY dependent. For the HT PHY, see 20.6.

The structure of the MCS Set field is defined in Figure 7-95o20.

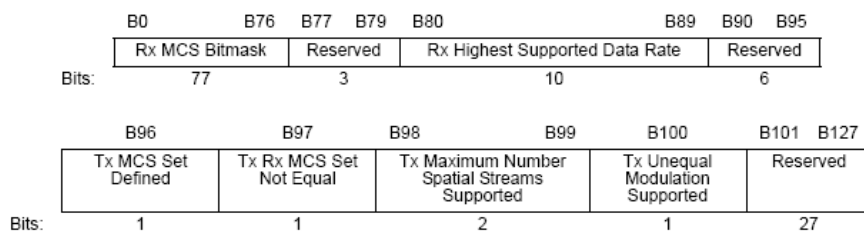

Figure 7-95o20—Supported MCS Set field

Section 20.6 defines the RX MCS Bitmask, and in particular Table 20.29 to Table 20.43 connect each index to a maximum number of spatial streams (Nss). For example:

The rate-dependent parameters for optional 20 MHz, $N_{SS} = 3$ MCSs with $N_{ES} = 1$ and EQM of the spatial streams shall be as shown in Table 20-31.

Table 20-31—MCS parameters for optional 20 MHz, $N_{SS} = 3$, $N_{ES} = 1$, EQM

MCS Index	Modulation	R	$N_{BPSCS}(i_{SS})$	N_{SD}	N_{SP}	N_{CBPS}	N_{DBPS}	Data rate (Mb/s)	
								800 ns GI	400 ns GI
16	BPSK	1/2	1	52	4	156	78	19.5	21.7
17	QPSK	1/2	2	52	4	312	156	39.0	43.3
18	QPSK	3/4	2	52	4	312	234	58.5	65.0
19	16-QAM	1/2	4	52	4	624	312	78.0	86.7
20	16-QAM	3/4	4	52	4	624	468	117.0	130.0
21	64-QAM	2/3	6	52	4	936	624	156.0	173.3
22	64-QAM	3/4	6	52	4	936	702	175.5	195.0
23	64-QAM	5/6	6	52	4	936	780	195.0	216.7

and a control unit which controls a processing of transmitting the value indicating possible multiplicity to the another radio apparatus at a predetermined timing:

As shown above, the MCS Set field, including the Rx MCS set, is part of the HT Capabilities element. The HT Capabilities element, including the Rx MCS set, is transmitted to another radio apparatus, as set forth below:

7.3.2.56.1 HT Capabilities element structure

An HT STA declares that it is an HT STA by transmitting the HT Capabilities element. The HT Capabilities element contains a number of fields that are used to advertise optional HT capabilities of an HT STA. The HT Capabilities element is present in Beacon, Association Request, Association Response, Reassociation Request, Reassociation Response, Probe Request, and Probe Response frames. The HT Capabilities element is defined in Figure 7-95o17.

The standard prescribes that the Beacon is transmitted at a predetermined timing, as set forth below:

11.1.1.1 TSF for infrastructure networks

In an infrastructure BSS, the AP shall be the timing master for the TSF. The AP shall initialize its TSF timer independently of any simultaneously started APs in an effort to minimize the synchronization of the TSF timers of multiple APs. The AP shall periodically transmit special frames called *Beacon frames* that contain a copy of its TSF timer to synchronize the TSF timers of other STAs in a BSS. A receiving STA shall always accept the timing information in Beacon frames sent from the AP servicing its BSS. If a STA's TSF timer is different from the timestamp in the received Beacon frame, the receiving STA shall set its local TSF timer to the received timestamp value.

Beacon frames shall be generated for transmission by the AP once every dot11BeaconPeriod TUs.

11.1.2 Maintaining synchronization

Each STA shall maintain a TSF timer with modulus 2^{64} counting in increments of microseconds. STAs expect to receive Beacon frames at a nominal rate. The interval between Beacon frames is defined by the dot11BeaconPeriod parameter of the STA. A STA sending a Beacon frame shall set the value of the Beacon frame's timestamp so that it equals the value of the STA's TSF timer at the time that the data symbol containing the first bit of the timestamp is transmitted to the PHY plus the transmitting STA's delays through its local PHY from the MAC-PHY interface to its interface with the WM [e.g., antenna, light-emitting diode (LED) emission surface].

51. On information and belief, these Accused Instrumentalities are used, marketed, provided to, and/or used by or for each of Defendants' partners, clients, customers and end users across the country and in this District.

52. Defendants were made aware of the '115 patent and their infringement thereof at least as early as March 31, 2016, when Mr. Chuck Hausmann, Esq., on behalf of Plaintiffs, sent a letter to Ms. Kathryn Tsigotis, Director of Licensing for Lenovo USA, disclosing the '115 patent and other of Plaintiffs' patents and alleging that Defendants' products infringed the '115 patent, among others.

53. Upon information and belief, since at least the time Defendants received notice, Defendants have induced and continue to induce others to infringe at least one claim of the '115 patent under 35 U.S.C. § 271(b) by, among other things, and with specific intent or willful blindness, actively aiding and abetting others to infringe, including but not limited to Defendants' partners, clients, customers, and end users, whose use of the Accused Instrumentalities constitutes direct infringement of at least one claim of the '115 patent.

54. In particular, Defendants' actions that aid and abet others such as its partners, customers, clients, and end users to infringe include advertising and distributing the Accused Instrumentalities and providing instruction materials, training, and services regarding the Accused Instrumentalities. On information and belief, Defendants have engaged in such actions with specific intent to cause infringement or with willful blindness to the resulting infringement

because Defendants have had actual knowledge of the '115 patent and knowledge that its acts were inducing infringement of the '115 patent since at least March 31, 2016.

55. Upon information and belief, Defendants are liable as contributory infringers of the '115 patent under 35 U.S.C. § 271(c) by offering to sell, selling and importing into the United States components to be especially made or adapted for use in an infringement of the '115 patent. The Accused Instrumentalities are a material component for use in practicing the '115 patent and are specifically made and are not a staple article of commerce suitable for substantial non-infringing use.

56. Since March 31, 2016, Defendants' infringement has been willful.

57. Plaintiffs have been harmed by Defendants' infringing activities.

COUNT III – INFRINGEMENT OF U.S. PATENT NO. 8,934,851

58. The allegations set forth in the foregoing paragraphs 1 through 57 are incorporated into this Third Claim for Relief.

59. On January 13, 2015, U.S. Patent No. 8,934,851 ("the '851 patent"), entitled "Radio Apparatus, and Method and Program for Controlling Spatial Path," was duly and legally issued by the United States Patent and Trademark Office. A true and correct copy of the '851 patent is attached as Exhibit 3.

60. Plaintiff Hera Wireless is the assignee and owner of the right, title and interest in and to the '851 patent. Plaintiffs have the right to assert all causes of action arising under said patent and the right to any remedies for infringement of them.

61. Upon information and belief, Defendants have and continue to directly infringe at least claims 1, 4, and 7 of the '851 patent by making, using, selling, importing and/or providing and causing to be used the Accused Instrumentalities, as defined above.

62. In particular, claim 1 of the '851 patent recites a radio apparatus capable of communicating with another radio apparatus comprising: a radio apparatus capable of communicating with another radio apparatus, comprising: a communication unit configured to communicate using an antenna; and a reception unit configured to receive, from said another radio apparatus, a value indicating possible multiplicity associated with the number of spatial paths that can be formed by said another radio apparatus, at a predetermined timing.

63. On information and belief, the Accused Instrumentalities infringe claim 1 of the '851 patent because they comply with IEEE Standard 802.11n-2009, which requires a radio apparatus capable of communicating with another radio apparatus (the block diagram below illustrates exemplary elements of the Accused Instrumentalities that function to generate a plurality of spatial paths according to the standard):

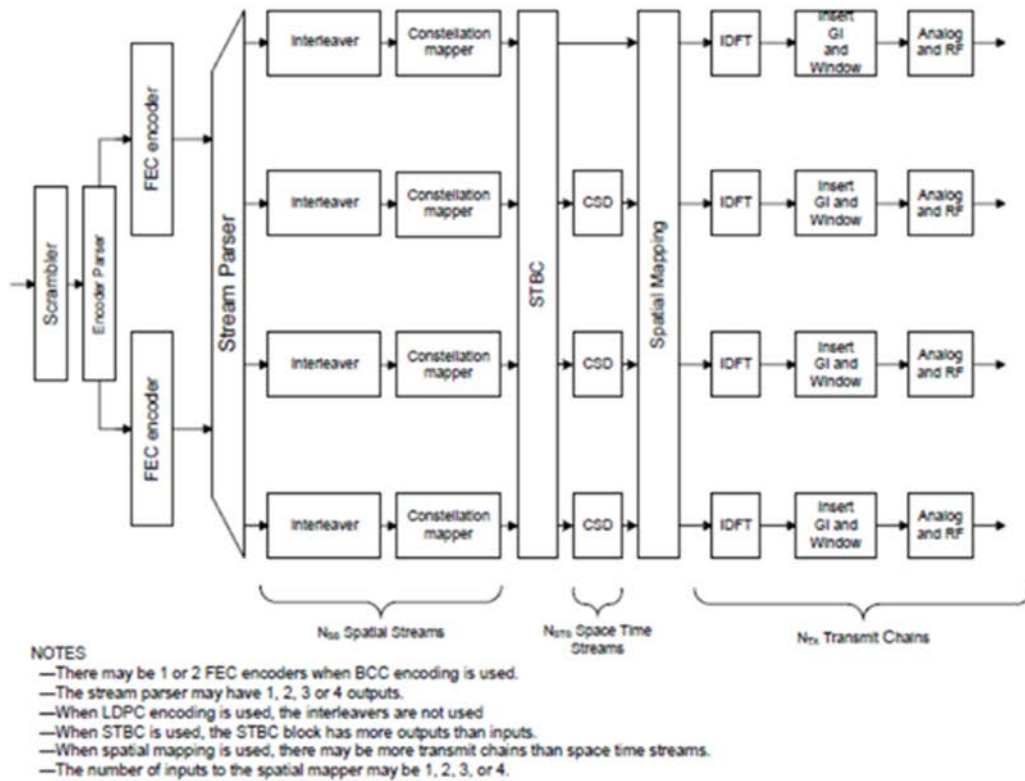

Figure 20-3—Transmitter block diagram 2

comprising: a communication unit configured to communicate using an antenna:

IEEE Std. 802.11n-2009

20.3.9 HT preamble

20.3.9.1 Introduction

The HT preambles are defined in HT-mixed format and in HT-greenfield format to carry the required information to operate in a system with multiple transmit and multiple receive antennas.

See also:

3.249 spatial stream: One of several streams of bits or modulation symbols that may be transmitted over multiple spatial dimensions that are created by the use of multiple antennas at both ends of a communications link.

and a reception unit configured to receive, from said another radio apparatus, a value indicating possible multiplicity associated with the number of spatial paths that can be formed by said another radio apparatus, at a predetermined timing:

IEEE Std. 802.11n-2009

7.3.2.56.4 Supported MCS Set field

The Supported MCS Set field of the HT Capabilities element indicates which MCSs a STA supports.

An MCS is identified by an MCS index, which is represented by an integer in the range 0 to 76. The interpretation of the MCS index (i.e., the mapping from MCS to data rate) is PHY dependent. For the HT PHY, see 20.6.

The structure of the MCS Set field is defined in Figure 7-95o20.

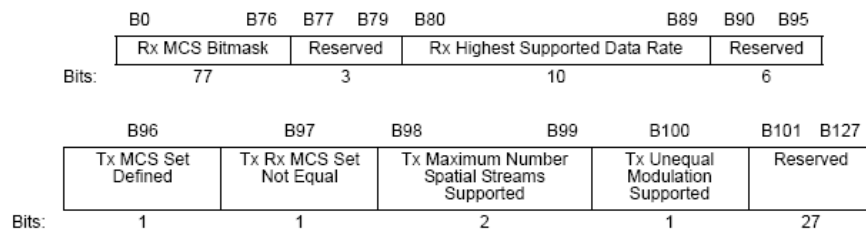

Figure 7-95o20—Supported MCS Set field

Section 20.6 defines the RX MCS Bitmask, and in particular Table 20.29 to Table 20.43 connect each index to a maximum number of spatial streams (N_{SS}). For example:

The rate-dependent parameters for optional 20 MHz, $N_{SS} = 3$ MCSs with $N_{ES} = 1$ and EQM of the spatial streams shall be as shown in Table 20-31.

Table 20-31—MCS parameters for optional 20 MHz, $N_{SS} = 3$, $N_{ES} = 1$, EQM

MCS Index	Modulation	R	$N_{BPSCS}(f_{SS})$	N_{SD}	N_{SP}	N_{CBPS}	N_{DBPS}	Data rate (Mb/s)	
								800 ns GI	400 ns GI
16	BPSK	1/2	1	52	4	156	78	19.5	21.7
17	QPSK	1/2	2	52	4	312	156	39.0	43.3
18	QPSK	3/4	2	52	4	312	234	58.5	65.0
19	16-QAM	1/2	4	52	4	624	312	78.0	86.7
20	16-QAM	3/4	4	52	4	624	468	117.0	130.0
21	64-QAM	2/3	6	52	4	936	624	156.0	173.3
22	64-QAM	3/4	6	52	4	936	702	175.5	195.0
23	64-QAM	5/6	6	52	4	936	780	195.0	216.7

As shown above, the MCS Set field, including the Rx MCS set, is part of the HT Capabilities element. The HT Capabilities element, including the Rx MCS set, is transmitted from another radio apparatus (and therefore received by the claimed apparatus), as set forth below:

7.3.2.56.1 HT Capabilities element structure

An HT STA declares that it is an HT STA by transmitting the HT Capabilities element. The HT Capabilities element contains a number of fields that are used to advertise optional HT capabilities of an HT STA. The HT Capabilities element is present in Beacon, Association Request, Association Response, Reassociation Request, Reassociation Response, Probe Request, and Probe Response frames. The HT Capabilities element is defined in Figure 7-95o17.

The standard prescribes that the Beacon is transmitted at a predetermined timing, as set forth below:

11.1.1.1 TSF for infrastructure networks

In an infrastructure BSS, the AP shall be the timing master for the TSF. The AP shall initialize its TSF timer independently of any simultaneously started APs in an effort to minimize the synchronization of the TSF timers of multiple APs. The AP shall periodically transmit special frames called *Beacon frames* that contain a copy of its TSF timer to synchronize the TSF timers of other STAs in a BSS. A receiving STA shall always accept the timing information in Beacon frames sent from the AP servicing its BSS. If a STA's TSF timer is different from the timestamp in the received Beacon frame, the receiving STA shall set its local TSF timer to the received timestamp value.

Beacon frames shall be generated for transmission by the AP once every dot11BeaconPeriod TUs.

11.1.2 Maintaining synchronization

Each STA shall maintain a TSF timer with modulus 2^{64} counting in increments of microseconds. STAs expect to receive Beacon frames at a nominal rate. The interval between Beacon frames is defined by the dot11BeaconPeriod parameter of the STA. A STA sending a Beacon frame shall set the value of the Beacon frame's timestamp so that it equals the value of the STA's TSF timer at the time that the data symbol containing the first bit of the timestamp is transmitted to the PHY plus the transmitting STA's delays through its local PHY from the MAC-PHY interface to its interface with the WM [e.g., antenna, light-emitting diode (LED) emission surface].

64. Claim 4 of the '851 patent recites a radio apparatus capable of communicating with another radio apparatus, comprising: a communication unit configured to communicate using a plurality of antennas; a storage unit configured to store beforehand a value indicating possible multiplicity associated with the number of spatial paths formable by said communication unit; and a control unit configured to control a processing of transmitting the value indicating possible multiplicity to the another radio apparatus at a predetermined timing.

65. On information and belief, the Accused Instrumentalities infringe claim 4 of the '851 patent because they comply with IEEE Standard 802.11n-2009, which requires a radio apparatus capable of communicating with another radio apparatus (the block diagram below illustrates exemplary elements of the Accused Instrumentalities that function to generate a plurality of spatial paths according to the standard):

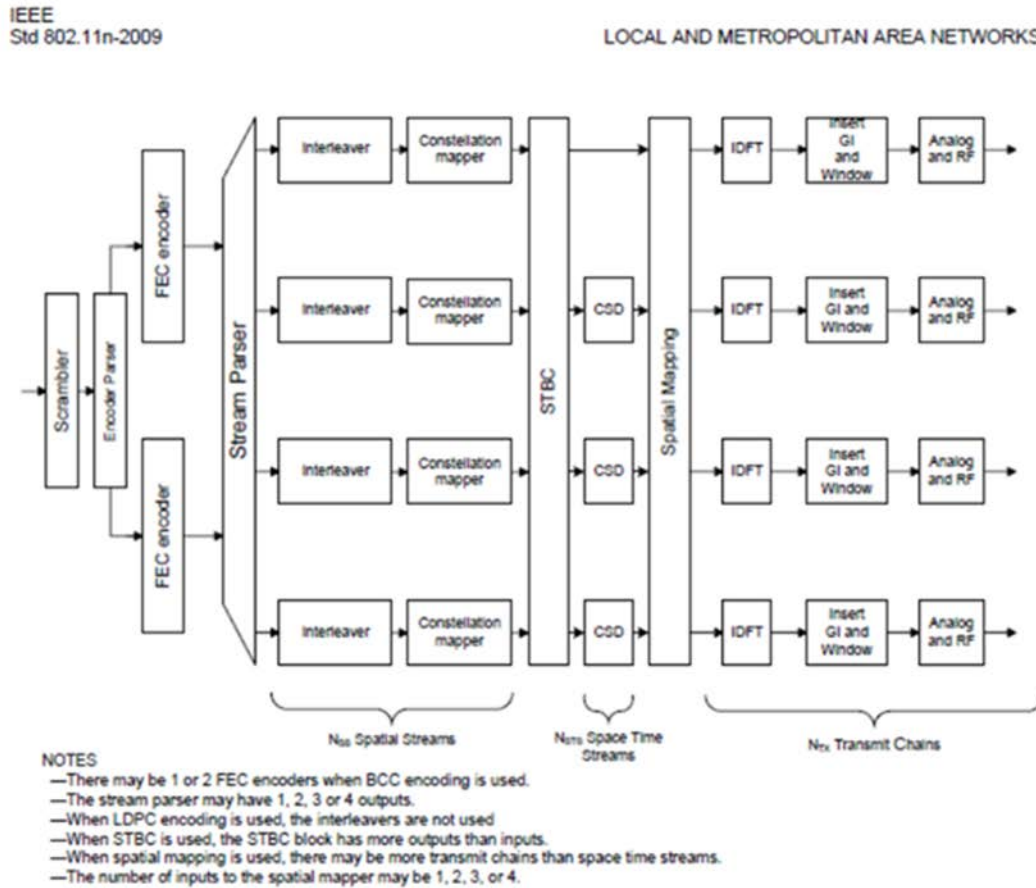

Figure 20-3—Transmitter block diagram 2

comprising: an antenna; a communication unit configured to communicate using a plurality of antennas:

IEEE Std. 802.11n-2009

20.3.9 HT preamble

20.3.9.1 Introduction

The HT preambles are defined in HT-mixed format and in HT-greenfield format to carry the required information to operate in a system with multiple transmit and multiple receive antennas.

See also:

3.249 spatial stream: One of several streams of bits or modulation symbols that may be transmitted over multiple spatial dimensions that are created by the use of multiple antennas at both ends of a communications link.

a storage unit configured to store beforehand a value indicating possible multiplicity associated with the number of spatial paths formable by said communication unit:

IEEE Std. 802.11n-2009

7.3.2.56.4 Supported MCS Set field

The Supported MCS Set field of the HT Capabilities element indicates which MCSs a STA supports.

An MCS is identified by an MCS index, which is represented by an integer in the range 0 to 76. The interpretation of the MCS index (i.e., the mapping from MCS to data rate) is PHY dependent. For the HT PHY, see 20.6.

The structure of the MCS Set field is defined in Figure 7-95o20.

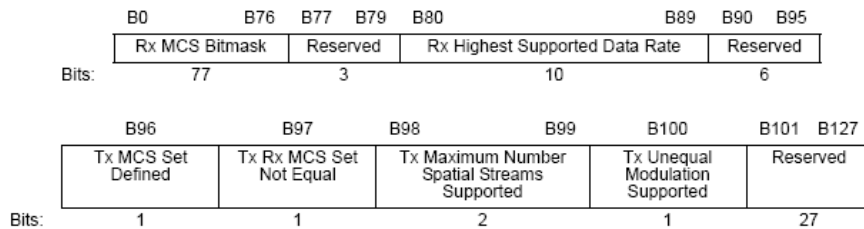

Figure 7-95o20—Supported MCS Set field

Section 20.6 defines the RX MCS Bitmask, and in particular Table 20.29 to Table 20.43 connect each index to a maximum number of spatial streams (N_{ss}). For example:

The rate-dependent parameters for optional 20 MHz, $N_{SS} = 3$ MCSs with $N_{ES} = 1$ and EQM of the spatial streams shall be as shown in Table 20-31.

Table 20-31—MCS parameters for optional 20 MHz, $N_{SS} = 3$, $N_{ES} = 1$, EQM

MCS Index	Modulation	R	$N_{BPSCS}(i_{SS})$	N_{SD}	N_{SP}	N_{CBPS}	N_{DBPS}	Data rate (Mb/s)	
								800 ns GI	400 ns GI
16	BPSK	1/2	1	52	4	156	78	19.5	21.7
17	QPSK	1/2	2	52	4	312	156	39.0	43.3
18	QPSK	3/4	2	52	4	312	234	58.5	65.0
19	16-QAM	1/2	4	52	4	624	312	78.0	86.7
20	16-QAM	3/4	4	52	4	624	468	117.0	130.0
21	64-QAM	2/3	6	52	4	936	624	156.0	173.3
22	64-QAM	3/4	6	52	4	936	702	175.5	195.0
23	64-QAM	5/6	6	52	4	936	780	195.0	216.7

and a control unit configured to control a processing of transmitting the value indicating possible multiplicity to said another radio apparatus, at a predetermined timing:

As shown above, the MCS Set field, including the Rx MCS set, is part of the HT Capabilities element. The HT Capabilities element, including the Rx MCS set, is transmitted to another radio apparatus, as set forth below:

7.3.2.56.1 HT Capabilities element structure

An HT STA declares that it is an HT STA by transmitting the HT Capabilities element. The HT Capabilities element contains a number of fields that are used to advertise optional HT capabilities of an HT STA. The HT Capabilities element is present in Beacon, Association Request, Association Response, Reassociation Request, Reassociation Response, Probe Request, and Probe Response frames. The HT Capabilities element is defined in Figure 7-95o17.

The standard prescribes that the Beacon is transmitted at a predetermined timing, as set forth below:

11.1.1.1 TSF for infrastructure networks

In an infrastructure BSS, the AP shall be the timing master for the TSF. The AP shall initialize its TSF timer independently of any simultaneously started APs in an effort to minimize the synchronization of the TSF timers of multiple APs. The AP shall periodically transmit special frames called *Beacon frames* that contain a copy of its TSF timer to synchronize the TSF timers of other STAs in a BSS. A receiving STA shall always accept the timing information in Beacon frames sent from the AP servicing its BSS. If a STA's TSF timer is different from the timestamp in the received Beacon frame, the receiving STA shall set its local TSF timer to the received timestamp value.

Beacon frames shall be generated for transmission by the AP once every dot11BeaconPeriod TUs.

11.1.2 Maintaining synchronization

Each STA shall maintain a TSF timer with modulus 2^{64} counting in increments of microseconds. STAs expect to receive Beacon frames at a nominal rate. The interval between Beacon frames is defined by the dot11BeaconPeriod parameter of the STA. A STA sending a Beacon frame shall set the value of the Beacon frame's timestamp so that it equals the value of the STA's TSF timer at the time that the data symbol containing the first bit of the timestamp is transmitted to the PHY plus the transmitting STA's delays through its local PHY from the MAC-PHY interface to its interface with the WM [e.g., antenna, light-emitting diode (LED) emission surface].

66. Claim 7 of the '851 patent recites a radio apparatus capable of communicating with another radio apparatus, comprising: a communication unit configured to communicate using a plurality of antennas; and a reception unit configured to receive, from said another radio apparatus, a value indicating possible multiplicity associated with the number of spatial paths that can be formed by said another radio apparatus, at a predetermined timing.

67. On information and belief, the Accused Instrumentalities infringe claim 7 of the '851 patent because they comply with IEEE Standard 802.11n-2009, which requires a radio apparatus capable of communicating with another radio apparatus (the block diagram below illustrates exemplary elements of the Accused Instrumentalities that function to generate a plurality of spatial paths according to the standard):

IEEE
Std 802.11n-2009

LOCAL AND METROPOLITAN AREA NETWORKS

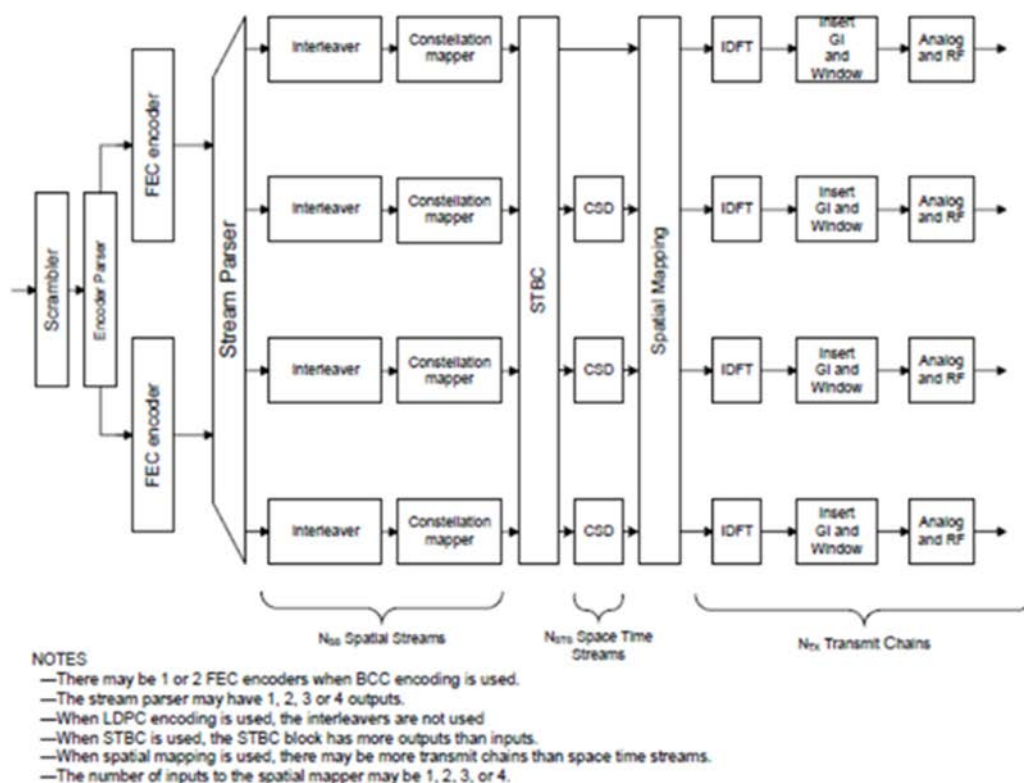

Figure 20-3—Transmitter block diagram 2

comprising: a communication unit configured to communicate using a plurality of antennas:

IEEE Std. 802.11n-2009

20.3.9 HT preamble

20.3.9.1 Introduction

The HT preambles are defined in HT-mixed format and in HT-greenfield format to carry the required information to operate in a system with multiple transmit and multiple receive antennas.

See also:

3.249 spatial stream: One of several streams of bits or modulation symbols that may be transmitted over multiple spatial dimensions that are created by the use of multiple antennas at both ends of a communications link.

a reception unit configured to receive, from said another radio apparatus, a value indicating possible multiplicity associated with the number of spatial paths that can be formed by said another radio apparatus, at a predetermined timing:

IEEE Std. 802.11n-2009

7.3.2.56.4 Supported MCS Set field

The Supported MCS Set field of the HT Capabilities element indicates which MCSs a STA supports.

An MCS is identified by an MCS index, which is represented by an integer in the range 0 to 76. The interpretation of the MCS index (i.e., the mapping from MCS to data rate) is PHY dependent. For the HT PHY, see 20.6.

The structure of the MCS Set field is defined in Figure 7-95o20.

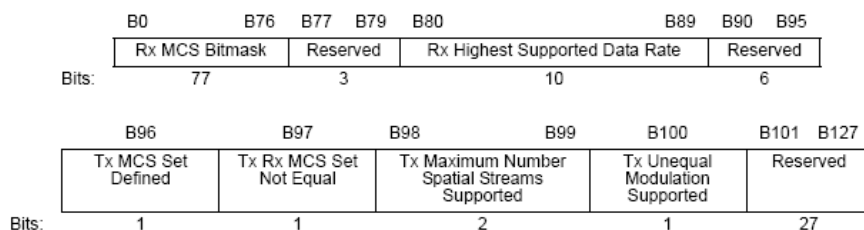

Figure 7-95o20—Supported MCS Set field

Section 20.6 defines the RX MCS Bitmask, and in particular Table 20.29 to Table 20.43 connect each index to a maximum number of spatial streams (N_{SS}). For example:

The rate-dependent parameters for optional 20 MHz, $N_{SS} = 3$ MCSs with $N_{ES} = 1$ and EQM of the spatial streams shall be as shown in Table 20-31.

Table 20-31—MCS parameters for optional 20 MHz, $N_{SS} = 3$, $N_{ES} = 1$, EQM

MCS Index	Modulation	R	$N_{BPSCS}(f_{SS})$	N_{SD}	N_{SP}	N_{CBPS}	N_{DBPS}	Data rate (Mb/s)	
								800 ns GI	400 ns GI
16	BPSK	1/2	1	52	4	156	78	19.5	21.7
17	QPSK	1/2	2	52	4	312	156	39.0	43.3
18	QPSK	3/4	2	52	4	312	234	58.5	65.0
19	16-QAM	1/2	4	52	4	624	312	78.0	86.7
20	16-QAM	3/4	4	52	4	624	468	117.0	130.0
21	64-QAM	2/3	6	52	4	936	624	156.0	173.3
22	64-QAM	3/4	6	52	4	936	702	175.5	195.0
23	64-QAM	5/6	6	52	4	936	780	195.0	216.7

As shown above, the MCS Set field, including the Rx MCS set, is part of the HT Capabilities element. The HT Capabilities element, including the Rx MCS set, is transmitted from another radio apparatus (and therefore received by the claimed apparatus), as set forth below:

7.3.2.56.1 HT Capabilities element structure

An HT STA declares that it is an HT STA by transmitting the HT Capabilities element. The HT Capabilities element contains a number of fields that are used to advertise optional HT capabilities of an HT STA. The HT Capabilities element is present in Beacon, Association Request, Association Response, Reassociation Request, Reassociation Response, Probe Request, and Probe Response frames. The HT Capabilities element is defined in Figure 7-95o17.

The standard prescribes that the Beacon is transmitted at a predetermined timing, as set forth below:

11.1.1.1 TSF for infrastructure networks

In an infrastructure BSS, the AP shall be the timing master for the TSF. The AP shall initialize its TSF timer independently of any simultaneously started APs in an effort to minimize the synchronization of the TSF timers of multiple APs. The AP shall periodically transmit special frames called *Beacon frames* that contain a copy of its TSF timer to synchronize the TSF timers of other STAs in a BSS. A receiving STA shall always accept the timing information in Beacon frames sent from the AP servicing its BSS. If a STA's TSF timer is different from the timestamp in the received Beacon frame, the receiving STA shall set its local TSF timer to the received timestamp value.

Beacon frames shall be generated for transmission by the AP once every dot11BeaconPeriod TUs.

11.1.2 Maintaining synchronization

Each STA shall maintain a TSF timer with modulus 2^{64} counting in increments of microseconds. STAs expect to receive Beacon frames at a nominal rate. The interval between Beacon frames is defined by the dot11BeaconPeriod parameter of the STA. A STA sending a Beacon frame shall set the value of the Beacon frame's timestamp so that it equals the value of the STA's TSF timer at the time that the data symbol containing the first bit of the timestamp is transmitted to the PHY plus the transmitting STA's delays through its local PHY from the MAC-PHY interface to its interface with the WM [e.g., antenna, light-emitting diode (LED) emission surface].

68. On information and belief, these Accused Instrumentalities are used, marketed, provided to, and/or used by or for each of Defendants' partners, clients, customers and end users across the country and in this District.

69. Defendants were made aware of the '851 patent and their infringement thereof at least as early as March 31, 2016, when Mr. Chuck Hausmann, Esq., on behalf of Plaintiffs, sent a letter to Ms. Kathryn Tsirigotis, Director of Licensing for Lenovo USA, disclosing the '851

patent and other of Plaintiffs' patents and alleging that Defendants' products infringed the '851 patent, among others.

70. Upon information and belief, since at least the time Defendants received notice, Defendants have induced and continue to induce others to infringe at least one claim of the '851 patent under 35 U.S.C. § 271(b) by, among other things, and with specific intent or willful blindness, actively aiding and abetting others to infringe, including but not limited to Defendants' partners, clients, customers, and end users, whose use of the Accused Instrumentalities constitutes direct infringement of at least one claim of the '851 patent.

71. In particular, Defendants' actions that aid and abet others such as its partners, customers, clients, and end users to infringe include advertising and distributing the Accused Instrumentalities and providing instruction materials, training, and services regarding the Accused Instrumentalities. On information and belief, Defendants have engaged in such actions with specific intent to cause infringement or with willful blindness to the resulting infringement because Defendants have had actual knowledge of the '851 patent and knowledge that its acts were inducing infringement of the '851 patent since at least March 31, 2016.

72. Upon information and belief, Defendants are liable as contributory infringers of the '851 patent under 35 U.S.C. § 271(c) by offering to sell, selling and importing into the United States components to be especially made or adapted for use in an infringement of the '851 patent. The Accused Instrumentalities are a material component for use in practicing the '851 patent and are specifically made and are not a staple article of commerce suitable for substantial non-infringing use.

73. Since March 31, 2016, Defendants' infringement has been willful.

74. Plaintiffs have been harmed by Defendants' infringing activities.

COUNT IV – INFRINGEMENT OF U.S. PATENT NO. 9,270,024

75. The allegations set forth in the foregoing paragraphs 1 through 74 are incorporated into this Fourth Claim for Relief.

76. On February 23, 2016, U.S. Patent No. 9,270,024 (“the ’024 patent”), entitled “Radio Apparatus, and Method and Program for Controlling Spatial Path,” was duly and legally issued by the United States Patent and Trademark Office. A true and correct copy of the ’024 patent is attached as Exhibit 4.

77. Plaintiff Hera Wireless is the assignee and owner of the right, title and interest in and to the ’024 patent. Plaintiffs have the right to assert all causes of action arising under said patent and the right to any remedies for infringement thereof.

78. Upon information and belief, Defendants have and continue to directly infringe at least claims 1 and 12 of the ’024 patent by making, using, selling, importing and/or providing and causing to be used the Accused Instrumentalities, as defined above.

79. In particular, claim 1 of the ’024 patent recites a radio apparatus for communication by forming a plurality of spatial signals to another radio apparatus, comprising: a plurality of transmission units connectable to a plurality of antennas; at least a signal processing unit capable of processing spatial signals to be transmitted through the plurality of transmission units and the plurality of antennas; storage means for storing in advance information on the number of spatial signals that can be processed by the signal processing unit, wherein the number of spatial signals is smaller than or equal to the total number of the plurality of antennas; a control means for controlling a process of transmitting the information on the number of spatial signals.

80. On information and belief, the Accused Instrumentalities infringe claim 1 of the ’024 patent because they comply with IEEE Standard 802.11n-2009, which requires a radio

apparatus for communication by forming a plurality of spatial signals to another radio apparatus, comprising: a plurality of transmission units connectable to a plurality of antennas (the block diagram below illustrates exemplary elements of the Accused Instrumentalities that function to generate a plurality of spatial signals according to the standard):

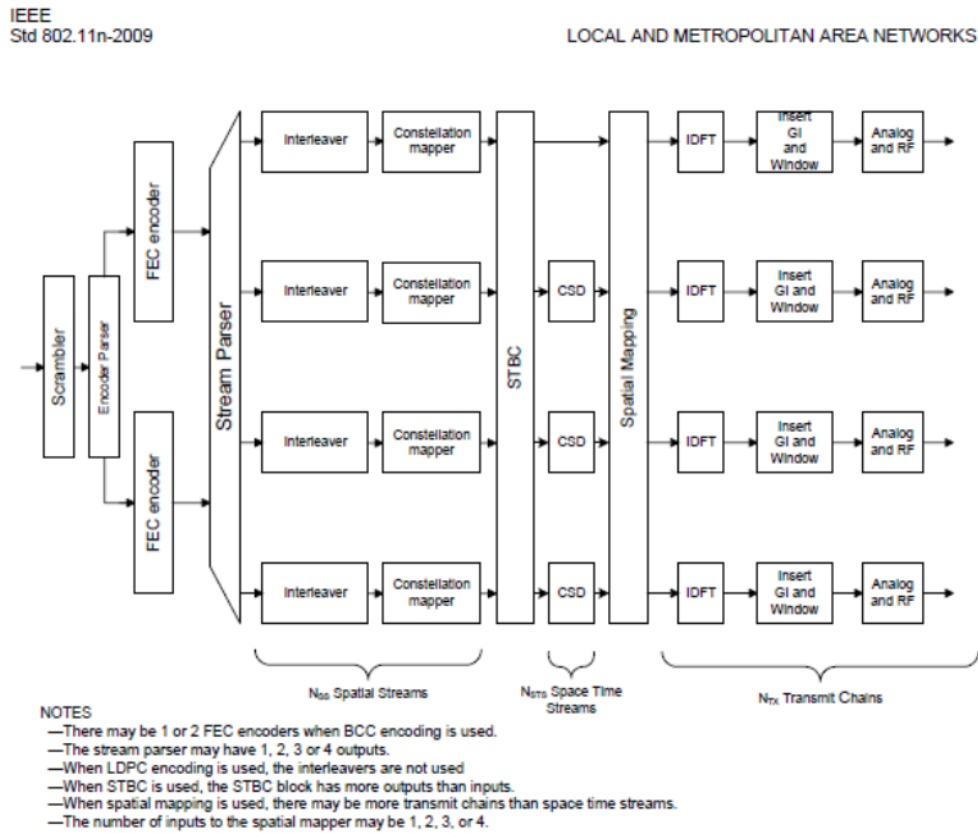

Figure 20-3—Transmitter block diagram 2

See also:

3.249 spatial stream: One of several streams of bits or modulation symbols that may be transmitted over multiple spatial dimensions that are created by the use of multiple antennas at both ends of a communications link.

at least a signal processing unit capable of processing spatial signals to be transmitted through the plurality of transmission units and the plurality of antennas:

The signal processing unit comprises a transmitter with the following functionality:

IEEE Std. 802.11n-2009

20.3.11.10.1 Spatial mapping

The transmitter may choose to rotate and/or scale the constellation mapper output vector (or the space-time block coder output, if applicable). This rotation and/or scaling is useful in the following cases:

- When there are more transmit chains than space-time streams,
- As part of (an optional) sounding packet
- As part of (an optional) calibration procedure
- When the packet is transmitted using one of the (optional) beamforming techniques

storage means for storing in advance information on the number of spatial signals that can be processed by the signal processing unit:

IEEE Std. 802.11n-2009

7.3.2.56.4 Supported MCS Set field

The Supported MCS Set field of the HT Capabilities element indicates which MCSs a STA supports.

An MCS is identified by an MCS index, which is represented by an integer in the range 0 to 76. The interpretation of the MCS index (i.e., the mapping from MCS to data rate) is PHY dependent. For the HT PHY, see 20.6.

The structure of the MCS Set field is defined in Figure 7-95o20.

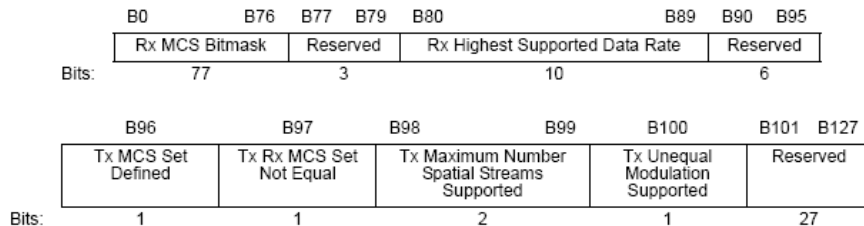

Figure 7-95o20—Supported MCS Set field

Section 20.6 defines the RX MCS Bitmask, and in particular Table 20.29 to Table 20.43 connect each index to a maximum number of spatial streams (N_{SS}). For example:

The rate-dependent parameters for optional 20 MHz, $N_{SS} = 3$ MCSs with $N_{ES} = 1$ and EQM of the spatial streams shall be as shown in Table 20-31.

Table 20-31—MCS parameters for optional 20 MHz, $N_{SS} = 3$, $N_{ES} = 1$, EQM

MCS Index	Modulation	R	$N_{BPSCS}(i_{SS})$	N_{SD}	N_{SP}	N_{CBPS}	N_{DBPS}	Data rate (Mb/s)	
								800 ns GI	400 ns GI
16	BPSK	1/2	1	52	4	156	78	19.5	21.7
17	QPSK	1/2	2	52	4	312	156	39.0	43.3
18	QPSK	3/4	2	52	4	312	234	58.5	65.0
19	16-QAM	1/2	4	52	4	624	312	78.0	86.7
20	16-QAM	3/4	4	52	4	624	468	117.0	130.0
21	64-QAM	2/3	6	52	4	936	624	156.0	173.3
22	64-QAM	3/4	6	52	4	936	702	175.5	195.0
23	64-QAM	5/6	6	52	4	936	780	195.0	216.7

wherein the number of spatial signals is smaller than or equal to the total number of the plurality of antennas:

As evidenced by Figure 20-3 below, the number of spatial signals is smaller than or equal to the total number of the plurality of antennas:

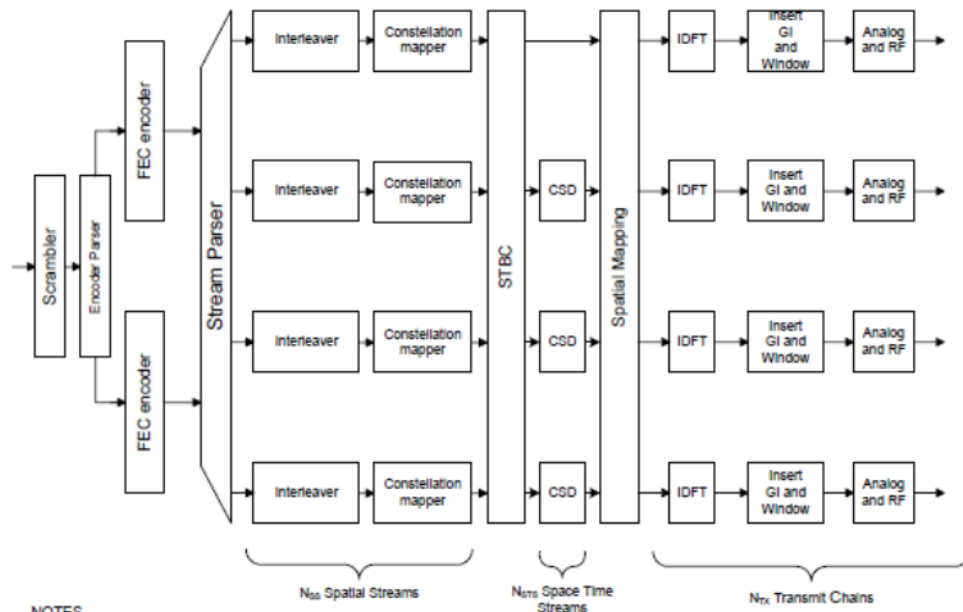

NOTES

- There may be 1 or 2 FEC encoders when BCC encoding is used.
- The stream parser may have 1, 2, 3 or 4 outputs.
- When LDPC encoding is used, the interleavers are not used.
- When STBC is used, the STBC block has more outputs than inputs.
- When spatial mapping is used, there may be more transmit chains than space time streams.
- The number of inputs to the spatial mapper may be 1, 2, 3, or 4.

Figure 20-3—Transmitter block diagram 2

See also:

3.249 spatial stream: One of several streams of bits or modulation symbols that may be transmitted over multiple spatial dimensions that are created by the use of multiple antennas at both ends of a communications link.

and a control unit for controlling a process of transmitting the information on the number of spatial signals:

As shown above, the MCS Set field, including the Rx MCS set, is part of the HT Capabilities element. The HT Capabilities element, including the Rx MCS set, is transmitted to another radio apparatus, as set forth below:

7.3.2.56.1 HT Capabilities element structure

An HT STA declares that it is an HT STA by transmitting the HT Capabilities element. The HT Capabilities element contains a number of fields that are used to advertise optional HT capabilities of an HT STA. The HT Capabilities element is present in Beacon, Association Request, Association Response, Reassociation Request, Reassociation Response,

Probe Request, and Probe Response frames. The HT Capabilities element is defined in Figure 7-95o17.

81. In particular, claim 12 of the '024 patent recites a radio apparatus for communication by forming a plurality of spatial signals to another radio apparatus, comprising: a plurality of transmission units connectable to a plurality of antennas; a signal processing unit capable of processing spatial signals to be transmitted through the plurality of transmission units and the plurality of antennas; a storage unit that stores in advance information on the number of spatial signals that can be processed by the signal processing unit, wherein the number of spatial signals is smaller than or equal to the total number of the plurality of antennas; a control unit for controlling a process of transmitting the information on the number of spatial signals.

82. On information and belief, the Accused Instrumentalities infringe claim 12 of the '024 patent because they comply with IEEE Standard 802.11n-2009, which requires a radio apparatus for communication by forming a plurality of spatial signals to another radio apparatus, comprising: a plurality of transmission units connectable to a plurality of antennas (the block diagram below illustrates exemplary elements of the Accused Instrumentalities that function to generate a plurality of spatial signals according to the standard):

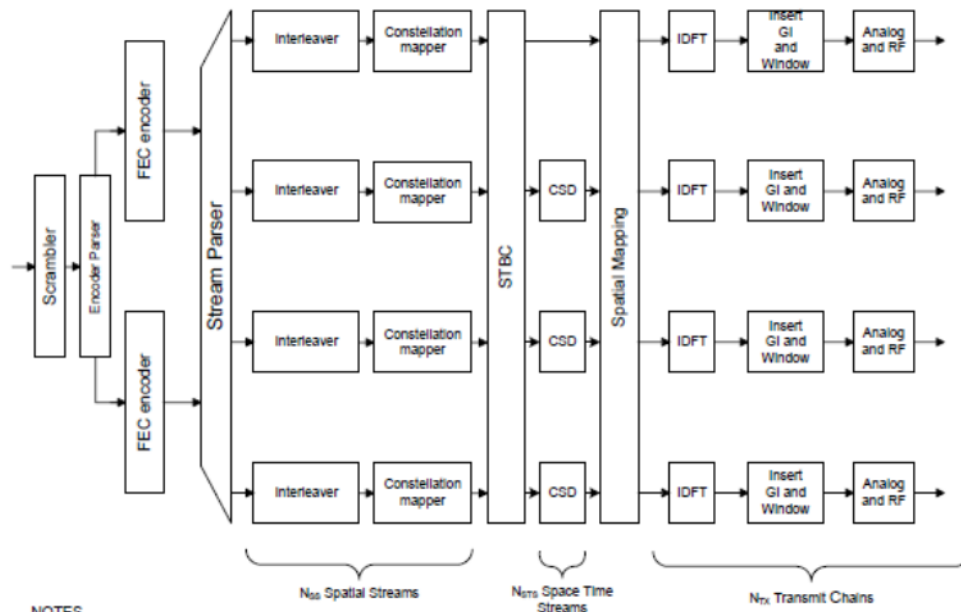

NOTES

- There may be 1 or 2 FEC encoders when BCC encoding is used.
- The stream parser may have 1, 2, 3 or 4 outputs.
- When LDPC encoding is used, the interleavers are not used.
- When STBC is used, the STBC block has more outputs than inputs.
- When spatial mapping is used, there may be more transmit chains than space time streams.
- The number of inputs to the spatial mapper may be 1, 2, 3, or 4.

Figure 20-3—Transmitter block diagram 2

See also:

3.249 spatial stream: One of several streams of bits or modulation symbols that may be transmitted over multiple spatial dimensions that are created by the use of multiple antennas at both ends of a communications link.

a signal processing unit capable of processing spatial signals to be transmitted through the plurality of transmission units and the plurality of antennas:

The signal processing unit comprises a transmitter with the following functionality:

IEEE Std. 802.11n-2009

20.3.11.10.1 Spatial mapping

The transmitter may choose to rotate and/or scale the constellation mapper output vector (or the space-time block coder output, if applicable). This rotation and/or scaling is useful in the following cases:

- When there are more transmit chains than space-time streams,

- As part of (an optional) sounding packet
- As part of (an optional) calibration procedure
- When the packet is transmitted using one of the (optional) beamforming techniques

a storage unit that stores in advance information on the number of spatial signals that can be processed by the signal processing unit:

IEEE Std. 802.11n-2009

7.3.2.56.4 Supported MCS Set field

The Supported MCS Set field of the HT Capabilities element indicates which MCSs a STA supports.

An MCS is identified by an MCS index, which is represented by an integer in the range 0 to 76. The interpretation of the MCS index (i.e., the mapping from MCS to data rate) is PHY dependent. For the HT PHY, see 20.6.

The structure of the MCS Set field is defined in Figure 7-95o20.

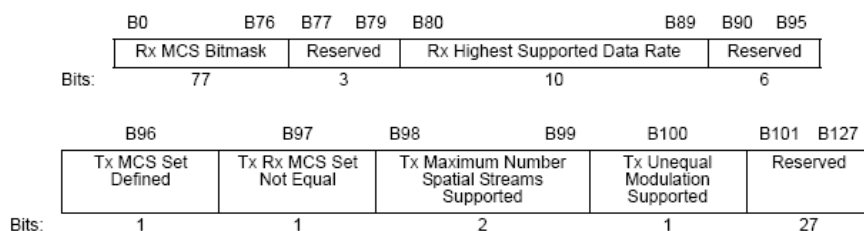

Figure 7-95o20—Supported MCS Set field

Section 20.6 defines the RX MCS Bitmask, and in particular Table 20.29 to Table 20.43 connect each index to a maximum number of spatial streams (N_{SS}). For example:

The rate-dependent parameters for optional 20 MHz, $N_{SS} = 3$ MCSs with $N_{ES} = 1$ and EQM of the spatial streams shall be as shown in Table 20-31.

Table 20-31—MCS parameters for optional 20 MHz, $N_{SS} = 3$, $N_{ES} = 1$, EQM

MCS Index	Modulation	R	$N_{BPSCS(iSS)}$	N_{SD}	N_{SP}	N_{CBPS}	N_{DBPS}	Data rate (Mb/s)	
								800 ns GI	400 ns GI
16	BPSK	1/2	1	52	4	156	78	19.5	21.7
17	QPSK	1/2	2	52	4	312	156	39.0	43.3
18	QPSK	3/4	2	52	4	312	234	58.5	65.0
19	16-QAM	1/2	4	52	4	624	312	78.0	86.7
20	16-QAM	3/4	4	52	4	624	468	117.0	130.0
21	64-QAM	2/3	6	52	4	936	624	156.0	173.3
22	64-QAM	3/4	6	52	4	936	702	175.5	195.0
23	64-QAM	5/6	6	52	4	936	780	195.0	216.7

wherein the number of spatial signals is smaller than or equal to the total number of the plurality of antennas:

As evidenced by Figure 20-3 below, the number of spatial signals is smaller than or equal to the total number of the plurality of antennas:

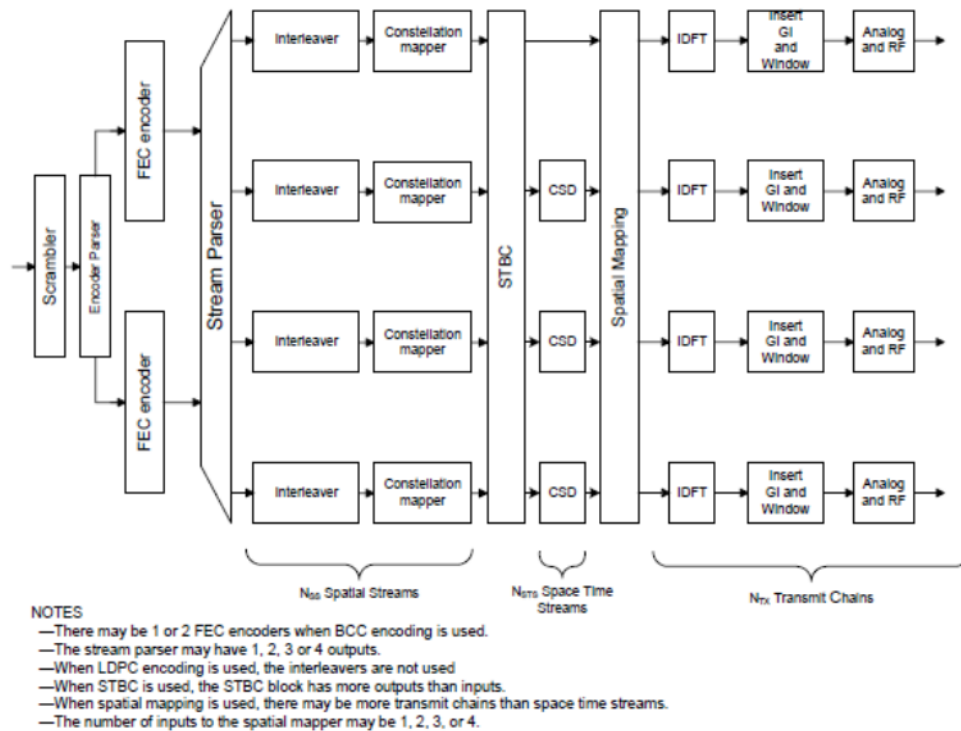

Figure 20-3—Transmitter block diagram 2

See also:

3.249 spatial stream: One of several streams of bits or modulation symbols that may be transmitted over multiple spatial dimensions that are created by the use of multiple antennas at both ends of a communications link.

and a control unit for controlling a process of transmitting the information on the number of spatial signals:

As shown above, the MCS Set field, including the Rx MCS set, is part of the HT Capabilities element. The HT Capabilities element, including the Rx MCS set, is transmitted to another radio apparatus, as set forth below:

7.3.2.56.1 HT Capabilities element structure

An HT STA declares that it is an HT STA by transmitting the HT Capabilities element. The HT Capabilities element contains a number of fields that are used to advertise optional HT capabilities of an HT STA. The HT Capabilities element is present in Beacon, Association Request, Association Response, Reassociation Request, Reassociation Response,

Probe Request, and Probe Response frames. The HT Capabilities element is defined in Figure 7-95o17.

83. On information and belief, these Accused Instrumentalities are used, marketed, provided to, and/or used by or for each of Defendants' partners, clients, customers and end users across the country and in this District.

84. Upon information and belief, Defendants have induced and continue to induce others to infringe at least one claim of the '024 patent under 35 U.S.C. § 271(b) by, among other things, and with specific intent or willful blindness, actively aiding and abetting others to infringe, including but not limited to Defendants' partners, clients, customers, and end users, whose use of the Accused Instrumentalities constitutes direct infringement of at least one claim of the '024 patent.

85. In particular, Defendants' actions that aid and abet others such as its partners, customers, clients, and end users to infringe include advertising and distributing the Accused Instrumentalities and providing instruction materials, training, and services regarding the Accused Instrumentalities.

86. Upon information and belief, Defendants are liable as contributory infringers of the '024 patent under 35 U.S.C. § 271(c) by offering to sell, selling and importing into the United States components to be especially made or adapted for use in an infringement of the '024 patent. The Accused Instrumentalities are a material component for use in practicing the '024 patent and are specifically made and are not a staple article of commerce suitable for substantial non-infringing use.

87. Plaintiffs have been harmed by Defendants' infringing activities.

COUNT V – INFRINGEMENT OF U.S. PATENT NO. 8,295,400

88. The allegations set forth in the foregoing paragraphs 1 through 87 are incorporated into this Fifth Claim for Relief.

89. On October 23, 2012, U.S. Patent No. 8,295,400 (“the ’400 patent”), entitled “Receiving Method and Apparatus, and Communicating System Using the Same,” was duly and legally issued by the United States Patent and Trademark Office. A true and correct copy of the ’400 patent is attached as Exhibit 5.

90. Plaintiff is the assignee and owner of the right, title and interest in and to the ’400 patent, including the right to assert all causes of action arising under said patents and the right to any remedies for infringement of them.

91. Upon information and belief, Defendants have and continue to directly infringe at least claims 1 and 2 of the ’400 patent by making, using, selling, importing and/or providing and causing to be used the Accused Instrumentalities, as defined above.

92. In particular, claim 1 of the ’400 patent recites a transmitting apparatus for transmitting an OFDM (Orthogonal Frequency Division Multiplexing) signal, comprising: a generator operative to generate a burst signal having a first burst format where a first Non-MIMO training signal, a first Non-MIMO signal, a MIMO signal, a MIMO training signal, and first data are arranged in the stated order; and a transmitter operative to transmit the burst signal generated by the generator, wherein a subcarrier carrying a first pilot signal included by frequency-division multiplexing in the first data in the first burst format of the burst signal generated by the generator is the same as a subcarrier carrying a second pilot signal included by frequency-division multiplexing in second data in a second format where a second Non-MIMO training signal, a second Non-MIMO signal, and the second data are arranged in the stated order, a modulation scheme of the first pilot signal is the same as a modulation scheme of the second

pilot signal, a pattern of the first pilot signal is different from a pattern of the second pilot signal, and the transmitter transmits the burst signal from a plurality of antennas such that the signal transmitted from a given one antenna is shifted in timing with respect to the signal transmitted from another antenna in a cyclical manner.

93. On information and belief, the Accused Instrumentalities infringe claim 1 of the '400 patent because they comply with IEEE Standard 802.11n-2009, which requires a transmitting apparatus for transmitting an OFDM signal:

IEEE Std. 802.11n-2009

20.1.1 Introduction to the HT PHY

Clause 20 specifies the PHY entity for a high throughput (HT) orthogonal frequency division multiplexing (OFDM) system.

In addition to the requirements found in Clause 20, an HT STA shall be capable of transmitting and receiving frames [...]

comprising: a generator operative to generate a burst signal having a first burst format where a first Non-MIMO training signal, a first Non-MIMO signal, a MIMO signal, a MIMO training signal, and first data are arranged in the stated order:

IEEE Std. 802.11n-2009

3A. Definitions specific to IEEE 802.11

3A.22 high-throughput-mixed (HT-mixed) format: A physical layer convergence procedure (PLCP) protocol data unit (PPDU) format of the HT physical layer (PHY) using the HT-mixed format preamble.

20.3.3 Transmitter block diagram

HT-mixed format and HT-greenfield format transmissions can be generated using a transmitter [...]

20.3.2 PPDU format

Two formats are defined for the PLCP: HT-mixed format and HT-greenfield format. These two formats are called *HT formats*. Figure 20-1 shows the non-HT format¹ and the HT formats. [...]

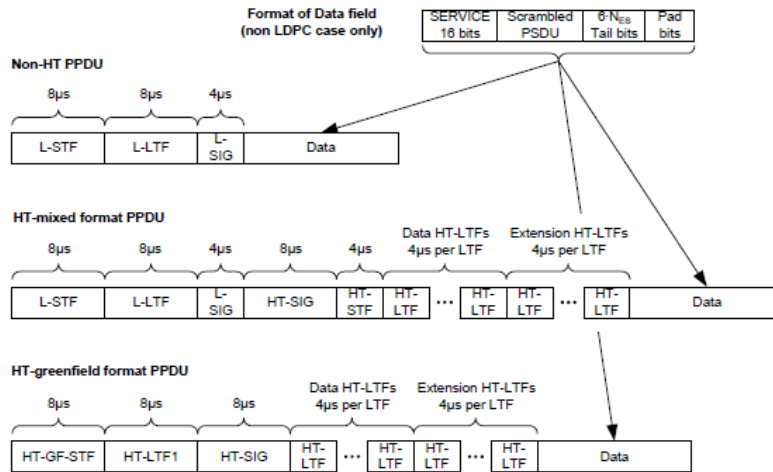

Figure 20-1—PPDU format

The elements of the PLCP packet are summarized in Table 20-4.

Table 20-4—Elements of the HT PLCP packet

Element	Description
L-STF	Non-HT Short Training field
L-LTF	Non-HT Long Training field
L-SIG	Non-HT SIGNAL field
HT-SIG	HT SIGNAL field
HT-STF	HT Short Training field
HT-GF-STF	HT-Greenfield Short Training field
HT-LTF1	First HT Long Training field (Data)
HT-LTFs	Additional HT Long Training fields (Data and Extension)
Data	The Data field includes the PSDU

20.3.9.2 HT-mixed format preamble

In HT-mixed format frames, the preamble has fields that support compatibility with Clause 17 and Clause 19 STAs and fields that support HT operation. The non-HT portion of the HT-mixed format preamble enables detection of the PPDU and acquisition of carrier frequency and timing by both HT STAs and STAs that are compliant with Clause 17 or Clause 19. [...] The HT portion of the HT-mixed format preamble enables estimation of the MIMO channel to support demodulation of the data portion of the frame by HT STAs.

20.3.9.3.3 L-STF definition

The L-STF is identical to the Clause 17 short training symbol.

20.3.9.3.4 L-LTF definition

The non-HT long training OFDM symbol is identical to the Clause 17 long training OFDM symbol.

During transmission, the PSDU shall be provided with a PLCP preamble and header to create the PPDU.

17.3.5.8 Pilot subcarriers

In each OFDM symbol, four of the subcarriers are dedicated to pilot signals in order to make the coherent detection robust against frequency offsets and phase noise. These pilot signals shall be put in subcarriers – 21, –7, 7, and 21. The pilots shall be BPSK modulated by a pseudo-binary sequence to prevent the generation of spectral lines. The contribution of the pilot subcarriers to each OFDM symbol is described in 17.3.5.9.

17.3.3 PLCP preamble (SYNC)

The PLCP Preamble field is used for synchronization. It consists of 10 short symbols and two long symbols that are shown in Figure 17-4 and described in this subclause. The timings described in this subclause and shown in Figure 17-4 are for 20 MHz channel spacing. They are doubled for half-clocked (i.e., 10 MHz) channel spacing and are quadrupled for quarter-clocked (i.e., 5 MHz) channel spacing.

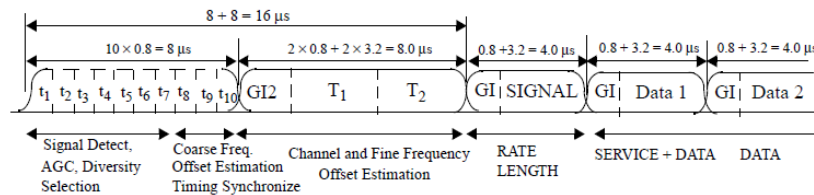

Figure 17-4—OFDM training structure

Figure 17-4 shows the OFDM training structure (PLCP preamble), where t1 to t10 denote short training symbols and T1 and T2 denote long training symbols. The PLCP preamble is followed by the SIGNAL field and DATA. The total training length is 16 μs. The dashed boundaries in the figure denote repetitions due to the periodicity of the inverse Fourier transform.

a modulation scheme of the first pilot signal is the same as a modulation scheme of the second pilot signal:

IEEE Std. 802.11n-2009

20.3.11.9 Pilot subcarriers

For a 20 MHz transmission, four pilot tones shall be inserted in the same subcarriers used in Clause 17, i.e., in subcarriers –21, –7, 7, and 21.

[...]

The basic patterns are also different according to the total number of space-time streams for the packet.

Table 20-18—Pilot values for 20 MHz transmission

N_{STS}	i_{STS}	$\Psi_{i_{STS} 0}^{(N_{STS})}$	$\Psi_{i_{STS} 1}^{(N_{STS})}$	$\Psi_{i_{STS} 2}^{(N_{STS})}$	$\Psi_{i_{STS} 3}^{(N_{STS})}$
1	1	1	1	1	-1
2	1	1	1	-1	-1
2	2	1	-1	-1	1
3	1	1	1	-1	-1
3	2	1	-1	1	-1

Table 20-18—Pilot values for 20 MHz transmission (continued)

N_{STS}	i_{STS}	$\Psi_{i_{STS} 0}^{(N_{STS})}$	$\Psi_{i_{STS} 1}^{(N_{STS})}$	$\Psi_{i_{STS} 2}^{(N_{STS})}$	$\Psi_{i_{STS} 3}^{(N_{STS})}$
3	3	-1	1	1	-1
4	1	1	1	1	-1
4	2	1	1	-1	1
4	3	1	-1	1	1
4	4	-1	1	1	1

IEEE Std. 802.11-2007

17.3.5.8 Pilot subcarriers

In each OFDM symbol, four of the subcarriers are dedicated to pilot signals in order to make the coherent detection robust against frequency offsets and phase noise. These pilot signals shall be put in subcarriers -21, -7, 7, and 21. The pilots shall be BPSK modulated by a pseudo-binary sequence to prevent the generation of spectral lines.

a pattern of the first pilot signal is different from a pattern of the second pilot signal:

IEEE Std. 802.11n-2009

20.3.11.9 Pilot subcarriers

For a 20 MHz transmission, four pilot tones shall be inserted in the same subcarriers used in Clause 17, i.e., in subcarriers -21, -7, 7, and 21. The pilot sequence for the n th symbols and i_{STS} th space-time stream shall be as shown in Equation (20-54).

Table 20-9—Cyclic shift values of HT portion of packet

T_{CS}^{HT} values for HT portion of packet				
Number of space-time streams	Cyclic shift for space-time stream 1 (ns)	Cyclic shift for space-time stream 2 (ns)	Cyclic shift for space-time stream 3 (ns)	Cyclic shift for space-time stream 4 (ns)
1	0	—	—	—
2	0	-400	—	—
3	0	-400	-200	—
4	0	-400	-200	-600

20.3.9.3.2 Cyclic shift definition

The cyclic shift values defined in this subclause apply to the non-HT fields in the HT-mixed format preamble and the HT-SIG in the HT-mixed format preamble.

Table 20-8—Cyclic shift for non-HT portion of packet

T_{CS}^{HTX} values for non-HT portion of packet				
Number of transmit chains	Cyclic shift for transmit chain 1 (ns)	Cyclic shift for transmit chain 2 (ns)	Cyclic shift for transmit chain 3 (ns)	Cyclic shift for transmit chain 4 (ns)
1	0	—	—	—
2	0	-200	—	—
3	0	-100	-200	—
4	0	-50	-100	-150

94. Claim 2 of the '400 patent recites a transmitting method for transmitting an OFDM signal, comprising: generating a burst signal having a first burst format where a first Non-MIMO training signal, a first Non-MIMO signal, a MIMO signal, a MIMO training signal, and first data are arranged in the stated order; and transmitting the burst signal, wherein a subcarrier carrying a first pilot signal included by frequency-division multiplexing in the first data in the first burst format is the same as a subcarrier carrying a second pilot signal included by frequency-division multiplexing in second data in a second format where a second Non-MIMO training signal, a second Non-MIMO signal, and the second data are arranged in the stated order, a modulation scheme of the first pilot signal is the same as a modulation scheme of the second pilot signal, a pattern of the first pilot signal is different from a pattern of the second pilot signal, and the transmitting transmits the burst signal from a plurality of antennas such that the signal

transmitted from a given one antenna is shifted in timing with respect to the signal transmitted from another antenna in a cyclical manner.

95. On information and belief, the Accused Instrumentalities infringe claim 2 of the '400 patent because they incorporate the method of IEEE Standard 802.11n-2009, which requires a transmitting method for transmitting an OFDM signal:

IEEE Std. 802.11n-2009

20.1.1 Introduction to the HT PHY

Clause 20 specifies the PHY entity for a high throughput (HT) orthogonal frequency division multiplexing (OFDM) system.

In addition to the requirements found in Clause 20, an HT STA shall be capable of transmitting and receiving frames [...]

comprising: generating a burst signal having a first burst format where a first Non-MIMO training signal, a first Non-MIMO signal, a MIMO signal, a MIMO training signal, and first data are arranged in the stated order:

IEEE Std. 802.11n-2009

3A. Definitions specific to IEEE 802.11

3A.22 high-throughput-mixed (HT-mixed) format: A physical layer convergence procedure (PLCP) protocol data unit (PPDU) format of the HT physical layer (PHY) using the HT-mixed format preamble.

20.3.3 Transmitter block diagram

HT-mixed format and HT-greenfield format transmissions can be generated using a transmitter [...]

20.3.2 PPDU format

Two formats are defined for the PLCP: HT-mixed format and HT-greenfield format. These two formats are called *HT formats*. Figure 20-1 shows the non-HT format¹ and the HT formats. [...]

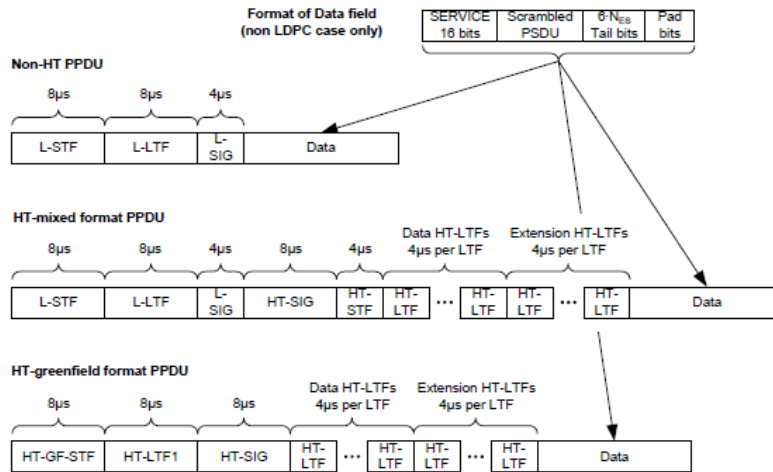

Figure 20-1—PPDU format

The elements of the PLCP packet are summarized in Table 20-4.

Table 20-4—Elements of the HT PLCP packet

Element	Description
L-STF	Non-HT Short Training field
L-LTF	Non-HT Long Training field
L-SIG	Non-HT SIGNAL field
HT-SIG	HT SIGNAL field
HT-STF	HT Short Training field
HT-GF-STF	HT-Greenfield Short Training field
HT-LTF1	First HT Long Training field (Data)
HT-LTFs	Additional HT Long Training fields (Data and Extension)
Data	The Data field includes the PSDU

20.3.9.2 HT-mixed format preamble

In HT-mixed format frames, the preamble has fields that support compatibility with Clause 17 and Clause 19 STAs and fields that support HT operation. The non-HT portion of the HT-mixed format preamble enables detection of the PPDU and acquisition of carrier frequency and timing by both HT STAs and STAs that are compliant with Clause 17 or Clause 19. [...] The HT portion of the HT-mixed format preamble enables estimation of the MIMO channel to support demodulation of the data portion of the frame by HT STAs.

20.3.9.3.3 L-STF definition

The L-STF is identical to the Clause 17 short training symbol.

20.3.9.3.4 L-LTF definition

The non-HT long training OFDM symbol is identical to the Clause 17 long training OFDM symbol.

17.3.5.8 Pilot subcarriers

In each OFDM symbol, four of the subcarriers are dedicated to pilot signals in order to make the coherent detection robust against frequency offsets and phase noise. These pilot signals shall be put in subcarriers -21 , -7 , 7 , and 21 . The pilots shall be BPSK modulated by a pseudo-binary sequence to prevent the generation of spectral lines. The contribution of the pilot subcarriers to each OFDM symbol is described in 17.3.5.9.

17.3.3 PLCP preamble (SYNC)

The PLCP Preamble field is used for synchronization. It consists of 10 short symbols and two long symbols that are shown in Figure 17-4 and described in this subclause. The timings described in this subclause and shown in Figure 17-4 are for 20 MHz channel spacing. They are doubled for half-clocked (i.e., 10 MHz) channel spacing and are quadrupled for quarter-clocked (i.e., 5 MHz) channel spacing.

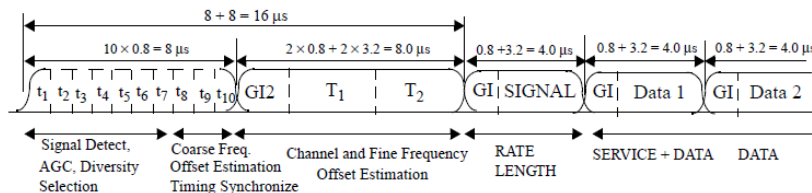

Figure 17-4—OFDM training structure

Figure 17-4 shows the OFDM training structure (PLCP preamble), where t_1 to t_{10} denote short training symbols and T_1 and T_2 denote long training symbols. The PLCP preamble is followed by the SIGNAL field and DATA. The total training length is $16 \mu s$. The dashed boundaries in the figure denote repetitions due to the periodicity of the inverse Fourier transform.

a modulation scheme of the first pilot signal is the same as a modulation scheme of the second pilot signal:

IEEE Std. 802.11n-2009

20.3.11.9 Pilot subcarriers

For a 20 MHz transmission, four pilot tones shall be inserted in the same subcarriers used in Clause 17, i.e., in subcarriers -21 , -7 , 7 , and 21 .

[...]

The basic patterns are also different according to the total number of space-time streams for the packet.

Table 20-18—Pilot values for 20 MHz transmission

N_{STS}	i_{STS}	$\Psi_{i_{STS} 0}^{(N_{STS})}$	$\Psi_{i_{STS} 1}^{(N_{STS})}$	$\Psi_{i_{STS} 2}^{(N_{STS})}$	$\Psi_{i_{STS} 3}^{(N_{STS})}$
1	1	1	1	1	-1
2	1	1	1	-1	-1
2	2	1	-1	-1	1
3	1	1	1	-1	-1
3	2	1	-1	1	-1

Table 20-18—Pilot values for 20 MHz transmission (continued)

N_{STS}	i_{STS}	$\Psi_{i_{STS} 0}^{(N_{STS})}$	$\Psi_{i_{STS} 1}^{(N_{STS})}$	$\Psi_{i_{STS} 2}^{(N_{STS})}$	$\Psi_{i_{STS} 3}^{(N_{STS})}$
3	3	-1	1	1	-1
4	1	1	1	1	-1
4	2	1	1	-1	1
4	3	1	-1	1	1
4	4	-1	1	1	1

IEEE Std. 802.11-2007**17.3.5.8 Pilot subcarriers**

In each OFDM symbol, four of the subcarriers are dedicated to pilot signals in order to make the coherent detection robust against frequency offsets and phase noise. These pilot signals shall be put in subcarriers -21 , -7 , 7 , and 21 . The pilots shall be BPSK modulated by a pseudo-binary sequence to prevent the generation of spectral lines.

a pattern of the first pilot signal is different from a pattern of the second pilot signal:

IEEE Std. 802.11n-2009**20.3.11.9 Pilot subcarriers**

For a 20 MHz transmission, four pilot tones shall be inserted in the same subcarriers used in Clause 17, i.e., in subcarriers -21 , -7 , 7 , and 21 . The pilot sequence for the n th symbols and i_{STS} th space-time stream shall be as shown in Equation (20-54).

Table 20-9—Cyclic shift values of HT portion of packet

$T_{CS}^{i_{SYS}}$ values for HT portion of packet				
Number of space-time streams	Cyclic shift for space-time stream 1 (ns)	Cyclic shift for space-time stream 2 (ns)	Cyclic shift for space-time stream 3 (ns)	Cyclic shift for space-time stream 4 (ns)
1	0	—	—	—
2	0	-400	—	—
3	0	-400	-200	—
4	0	-400	-200	-600

20.3.9.3.2 Cyclic shift definition

The cyclic shift values defined in this subclause apply to the non-HT fields in the HT-mixed format preamble and the HT-SIG in the HT-mixed format preamble.

Table 20-8—Cyclic shift for non-HT portion of packet

$T_{CS}^{i_{TX}}$ values for non-HT portion of packet				
Number of transmit chains	Cyclic shift for transmit chain 1 (ns)	Cyclic shift for transmit chain 2 (ns)	Cyclic shift for transmit chain 3 (ns)	Cyclic shift for transmit chain 4 (ns)
1	0	—	—	—
2	0	-200	—	—
3	0	-100	-200	—
4	0	-50	-100	-150

96. On information and belief, these Accused Instrumentalities are used, marketed, provided to, and/or used by or for each of Defendants' partners, clients, customers and end users across the country and in this District.

97. Defendants were made aware of the '400 patent and their infringement thereof at least as early as March 31, 2016, when Mr. Chuck Hausmann, Esq., on behalf of Plaintiff, sent a letter to Ms. Kathryn Tsigotis, Director of Licensing for Lenovo USA, disclosing the '400 patent and other of Plaintiff's patents and alleging that Defendants' products infringed the '400 patent, among others.

98. Upon information and belief, since at least the time Defendants received notice, Defendants have induced and continue to induce others to infringe at least one claim of the '400 patent under 35 U.S.C. § 271(b) by, among other things, and with specific intent or willful

blindness, actively aiding and abetting others to infringe, including but not limited to Defendants' partners, clients, customers, and end users, whose use of the Accused Instrumentalities constitutes direct infringement of at least one claim of the '400 patent.

99. In particular, Defendants' actions that aid and abet others such as its partners, customers, clients, and end users to infringe include advertising and distributing the Accused Instrumentalities and providing instruction materials, training, and services regarding the Accused Instrumentalities. On information and belief, Defendants have engaged in such actions with specific intent to cause infringement or with willful blindness to the resulting infringement because Defendants have had actual knowledge of the '400 patent and knowledge that its acts were inducing infringement of the '400 patent since at least March 31, 2016.

100. Upon information and belief, Defendants are liable as contributory infringers of the '400 patent under 35 U.S.C. § 271(c) by offering to sell, selling and importing into the United States components to be especially made or adapted for use in an infringement of the '400 patent. The Accused Instrumentalities are a material component for use in practicing the '400 patent and are specifically made and are not a staple article of commerce suitable for substantial non-infringing use.

101. Since March 31, 2016, Defendants' infringement has been willful.

102. Plaintiff has been harmed by Defendants' infringing activities.

COUNT VI – INFRINGEMENT OF U.S. PATENT NO. 7,369,878

103. The allegations set forth in the foregoing paragraphs 1 through 102 are incorporated into this Sixth Claim for Relief.

104. On May 6, 2008, U.S. Patent No. 7,369,878 (“the '878 patent”), entitled “Radio Base Station Apparatus, Radio Terminal Apparatus, Mobile Communications System, and

Reception Operation Control Program,” was duly and legally issued by the United States Patent and Trademark Office. A true and correct copy of the ’878 patent is attached as Exhibit 6.

105. Plaintiff is the assignee and owner of the right, title and interest in and to the ’878 patent, including the right to assert all causes of action arising under said patents and the right to any remedies for infringement of them.

106. Upon information and belief, Defendants have and continue to directly infringe at least claim 1 of the ’878 patent by making, using, selling, importing and/or providing and causing to be used the Accused Instrumentalities, as defined above.

107. In particular, claim 1 of the ’878 patent recites a radio base station apparatus for transmitting a frame to a radio terminal apparatus, the radio base station apparatus comprising: a receiver for receiving a connection request from the radio terminal apparatus; and a transmitter for transmitting the frame to the radio terminal apparatus which has sent the connection request, the frame including (1) a signal indicating a reception operation adapted to a transmission operation of the radio base station apparatus and (2) data; wherein the signal is a having first and second bit values which specify first and second reception operations, respectively, one of the first and second bit values instructing the radio terminal apparatus to accept the frame only in a prescribed manner determined by the one bit value and adapted to a corresponding transmission operation of the radio base station apparatus.

108. On information and belief, the Accused Instrumentalities infringe claim 1 of the ’878 patent because they comply with IEEE Standard 802.11n-2009, which recommends a radio base station apparatus (“access point” or “AP” below) for transmitting a frame (“PPDU” below) to a radio terminal apparatus (“STA” below), the radio base station apparatus comprising:

IEEE Std. 802.11n-2009

5.2.9 High-throughput (HT) station (STA)

The IEEE 802.11 HT STA provides physical layer (PHY) and medium access control (MAC) features that can support a throughput of 100 Mb/s and greater, as measured at the MAC data service access point (SAP).

An HT STA supports HT features as identified in Clause 9 and Clause 20.

...

The HT features are available to HT STAs associated with an HT access point (AP) in a basic service set (BSS).

...

An HT STA has PHY features consisting of the modulation and coding scheme (MCS) set described in 20.3.5 and physical layer convergence procedure (PLCP) protocol data unit (PPDU) formats described in 20.1.4.

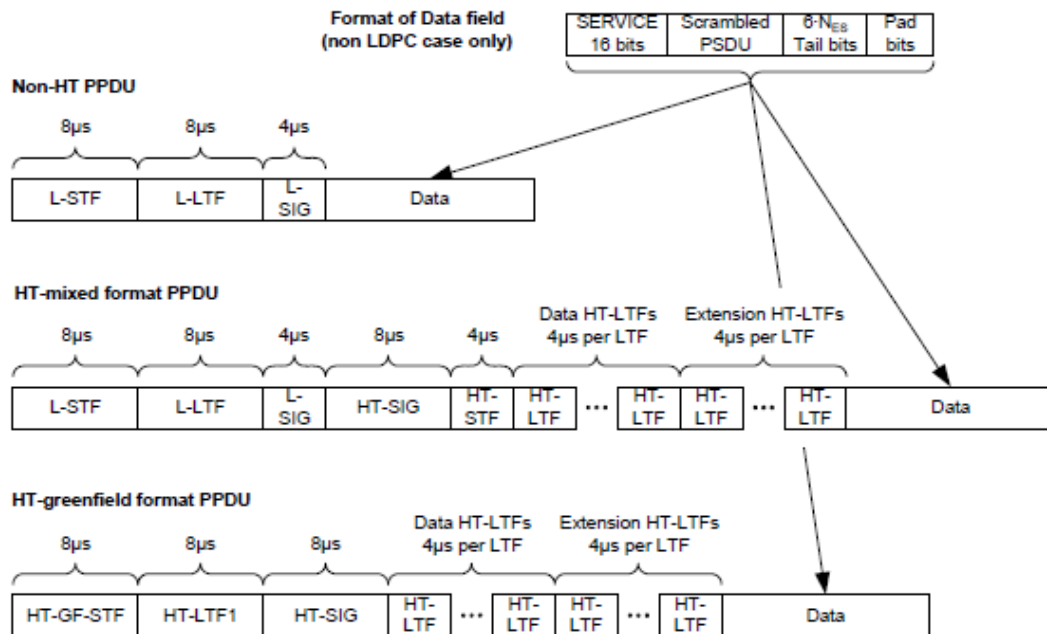

Figure 20-1—PPDU format

a receiver for receiving a connection request from the radio terminal apparatus:

IEEE Std. 802.11-2007

11.3.2.2 AP association procedures

When an Association Request frame is received from a STA, the AP shall associate with the STA using the following procedure . . .

IEEE Std. 802.11n-2009

11.3.2.2 AP association procedures

Insert the following list items (b2 and b3) after item b1) in 11.3.2.2 as follows:

- b2) An AP shall refuse an association request from a STA that does not support all the rates in the BSSBasicRateSet parameter.
- b3) An AP shall refuse an association request from an HT STA that does not support all the MCSs in the BSSBasicMCSSet parameter.

a transmitter for transmitting the frame to the radio terminal apparatus which has sent the connection request:

IEEE Std. 802.11-2007

11.3.2.2 AP association procedures

When an Association Request frame is received from a STA, the AP shall associate with the STA using the following procedure:

- a) If the STA is not authenticated, the AP shall transmit a Deauthentication frame to the STA and terminate the association procedure.
- b) In an RSNA, the AP shall check the values received in the RSN information element to see whether the values received match the AP's security policy. If not, the association shall not be accepted.
- c) Upon receipt of an MLME-Associate.response service primitive, the AP shall transmit an Association Response with a status code as defined in 7.3.1.9. If the status value is "successful," the association identifier assigned to the STA shall be included in the response.

the frame including (1) a signal indicating a reception operation adapted to a transmission operation of the radio base station apparatus and (2) data:

IEEE Std. 802.11n-2009

20.3.2 PPDU format

Two formats are defined for the PLCP: HT-mixed format and HT-greenfield format. These two formats are called HT formats. Figure 20-1 shows the non-HT format and the HT formats.

Table 20-10—HT-SIG fields (continued)

Field	Number of bits	Explanation and coding
Smoothing	1	Set to 1 indicates that channel estimate smoothing is recommended. Set to 0 indicates that only per-carrier independent (unsmoothed) channel estimate is recommended. See 20.3.11.10.1.

wherein the signal is a bit having first and second bit values which specify first and second reception operations, respectively, one of the first and second bit values instructing the radio terminal apparatus to accept the frame only in a prescribed manner determined by the one bit value and adapted to a corresponding transmission operation of the radio base station apparatus:

IEEE Std. 802.11n-2009

20.3.9.4.3 HT-SIG definition

The HT-SIG is used to carry information required to interpret the HT packet formats. The fields of the HT-SIG are described in Table 20-10.

Table 20-10—HT-SIG fields (continued)

Field	Number of bits	Explanation and coding
Smoothing	1	Set to 1 indicates that channel estimate smoothing is recommended. Set to 0 indicates that only per-carrier independent (unsmoothed) channel estimate is recommended. See 20.3.11.10.1.

109. On information and belief, these Accused Instrumentalities are used, marketed, provided to, and/or used by or for each of Defendants' partners, clients, customers and end users across the country and in this District.

110. Defendants were made aware of the '878 patent and their infringement thereof at least as early as March 31, 2016, when Mr. Chuck Hausmann, Esq., on behalf of Plaintiff, sent a letter to Ms. Kathryn Tsigotis, Director of Licensing for Lenovo USA, disclosing the '878

patent and other of Plaintiff's patents and alleging that Defendants' products infringed the '878 patent, among others.

111. Upon information and belief, since at least the time Defendants received notice, Defendants have induced and continue to induce others to infringe at least one claim of the '878 patent under 35 U.S.C. § 271(b) by, among other things, and with specific intent or willful blindness, actively aiding and abetting others to infringe, including but not limited to Defendants' partners, clients, customers, and end users, whose use of the Accused Instrumentalities constitutes direct infringement of at least one claim of the '878 patent.

112. In particular, Defendants' actions that aid and abet others such as its partners, customers, clients, and end users to infringe include advertising and distributing the Accused Instrumentalities and providing instruction materials, training, and services regarding the Accused Instrumentalities. On information and belief, Defendants have engaged in such actions with specific intent to cause infringement or with willful blindness to the resulting infringement because Defendants have had actual knowledge of the '878 patent and knowledge that its acts were inducing infringement of the '878 patent since at least March 31, 2016.

113. Upon information and belief, Defendants are liable as contributory infringers of the '878 patent under 35 U.S.C. § 271(c) by offering to sell, selling and importing into the United States components to be especially made or adapted for use in an infringement of the '878 patent. The Accused Instrumentalities are a material component for use in practicing the '878 patent and are specifically made and are not a staple article of commerce suitable for substantial non-infringing use.

114. Since March 31, 2016, Defendants' infringement has been willful.

115. Plaintiff has been harmed by Defendants' infringing activities.

COUNT VII – INFRINGEMENT OF U.S. PATENT NO. 7,454,234

116. The allegations set forth in the foregoing paragraphs 1 through 115 are incorporated into this Seventh Claim for Relief.

117. On November 18, 2008, U.S. Patent No. 7,454,234 (“the ’234 patent”), entitled “Radio Base Station Apparatus, Radio Terminal Apparatus, Mobile Communications System, and Reception Operation Control Program,” was duly and legally issued by the United States Patent and Trademark Office. A true and correct copy of the ’234 patent is attached as Exhibit 7.

118. Plaintiff is the assignee and owner of the right, title and interest in and to the ’234 patent, including the right to assert all causes of action arising under said patents and the right to any remedies for infringement of them.

119. Upon information and belief, Defendants have and continue to directly infringe at least claim 1 of the ’234 patent by making, using, selling, importing and/or providing and causing to be used the Accused Instrumentalities, as defined above.

120. In particular, claim 1 of the ’234 patent recites a radio base station apparatus for transmitting a multiple-field frame to a radio terminal apparatus, the radio base station apparatus comprising: a receiver for receiving a connection request from the radio terminal apparatus; and a transmitter for transmitting the multiple-field frame to the radio terminal apparatus which has sent the connection request wherein control information and first data are respectively contained in mutually different fields in the multiple-field frame, and the control information contains (1) a single bit indicating a reception operation adapted to a transmission operation of the radio base station apparatus and (2) second data for communication control.

121. On information and belief, the Accused Instrumentalities infringe claim 1 of the ’234 patent because they comply with IEEE Standard 802.11n-2009, which recommends a radio base station apparatus (“access point” or “AP” below) for transmitting a multiple-field frame (“HT-

mixed format PPDU” below) to a radio terminal apparatus (“STA” below), the radio base station apparatus comprising:

IEEE Std. 802.11n-2009

5.2.9 High-throughput (HT) station (STA)

The IEEE 802.11 HT STA provides physical layer (PHY) and medium access control (MAC) features that can support a throughput of 100 Mb/s and greater, as measured at the MAC data service access point (SAP).

An HT STA supports HT features as identified in Clause 9 and Clause 20.

...

The HT features are available to HT STAs associated with an HT access point (AP) in a basic service set (BSS).

...

An HT STA has PHY features consisting of the modulation and coding scheme (MCS) set described in 20.3.5 and physical layer convergence procedure (PLCP) protocol data unit (PPDU) formats described in 20.1.4.

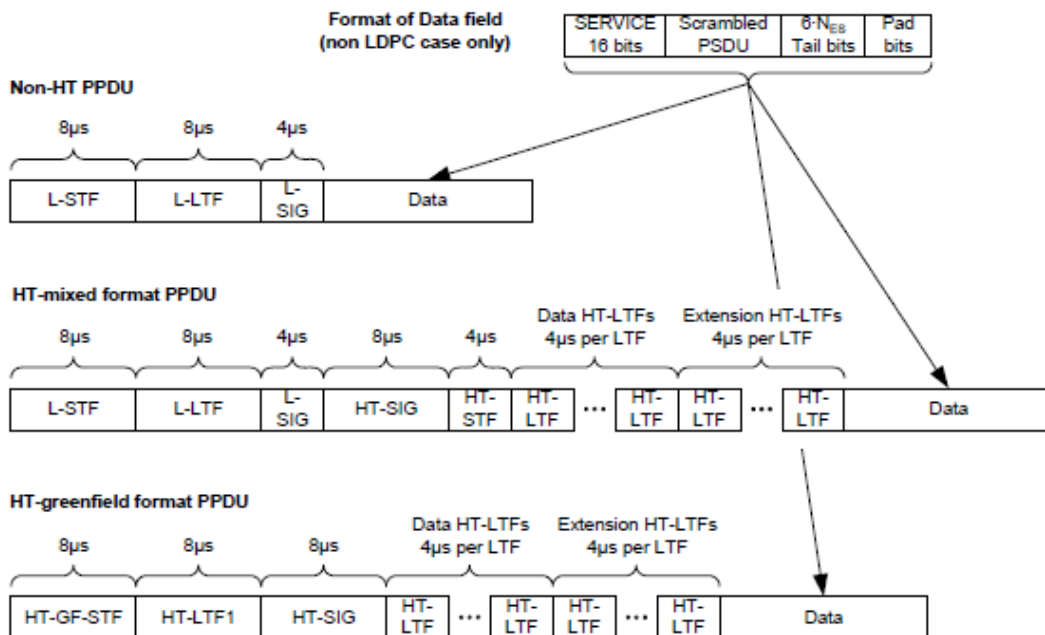

Figure 20-1—PPDU format

a receiver for receiving a connection request from the radio terminal apparatus:

IEEE Std. 802.11-2007

11.3.2.2 AP association procedures

When an Association Request frame is received from a STA, the AP shall associate with the STA using the following procedure . . .

IEEE Std. 802.11n-2009

11.3.2.2 AP association procedures

Insert the following list items (b2 and b3) after item b1) in 11.3.2.2 as follows:

b2) An AP shall refuse an association request from a STA that does not support all the rates in the BSSBasicRateSet parameter.

b3) An AP shall refuse an association request from an HT STA that does not support all the MCSs in the BSSBasicMCSSet parameter.

a transmitter for transmitting the multiple-field frame to the radio terminal apparatus which has sent the connection request wherein control information and first data are respectively contained in mutually different fields in the multiple-field frame:

The AP includes a transmitter for transmitting the HT-mixed format PPDU (multiple-field frame) to the STA that sent the association request frame. The HT-SIG (control information) and Data are respectively contained in mutually different fields of the HT-mixed format PPDU, as shown in Figure 20-1 below.

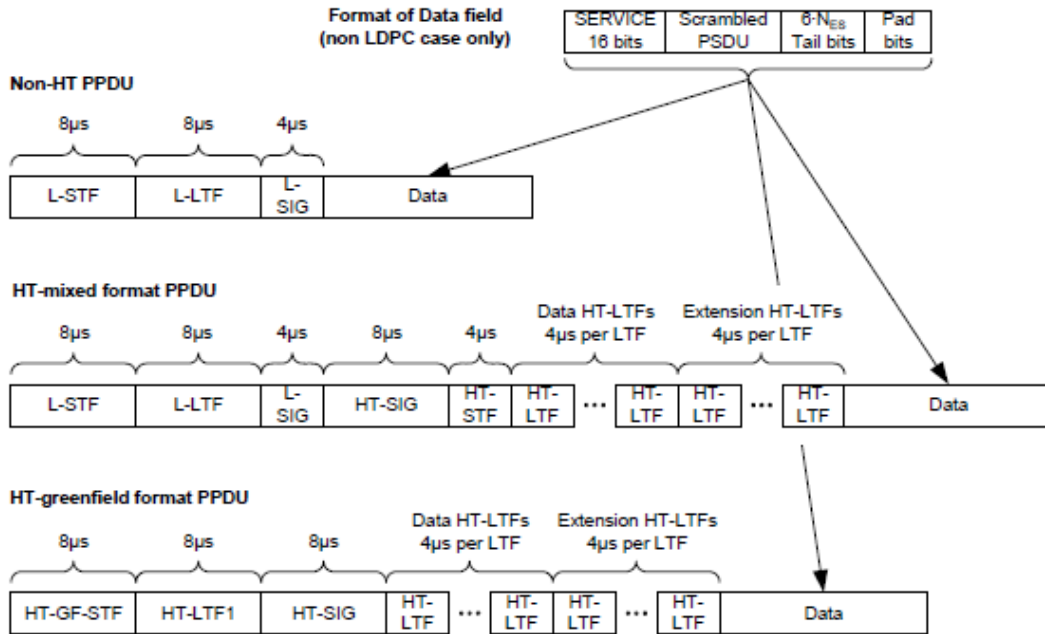

Figure 20-1—PPDU format

and the control information contains (1) single bit indicating a reception operation adapted to a transmission operation of the radio base station apparatus and (2) second data for communication control:

As shown below in Table 20-11—HT-SIG fields, the control information, HT-SIG, contains a single bit for smoothing, which is a reception operation adapted to a transmission operation of the radio base station apparatus (STA). The control information, HT-SIG, also contains second data (“Modulation and Coding Scheme” below) for communication control:

Table 20-11—HT-SIG fields

Field	Number of bits	Explanation and coding
Modulation and Coding Scheme	7	Index into the MCS table. See NOTE 1.
CBW 20/40	1	Set to 0 for 20 MHz or 40 MHz upper/lower. Set to 1 for 40 MHz.
HT Length	16	The number of octets of data in the PSDU in the range of 0 to 65 535. See NOTE 1 and NOTE 2.
Smoothing	1	Set to 1 indicates that channel estimate smoothing is recommended. Set to 0 indicates that only per-carrier independent (unsmoothed) channel estimate is recommended. See 20.3.11.11.2.
Not Sounding	1	Set to 0 indicates that PPDU is a sounding PPDU.

122. On information and belief, these Accused Instrumentalities are used, marketed, provided to, and/or used by or for each of Defendants' partners, clients, customers and end users across the country and in this District.

123. Defendants were made aware of the '234 patent and their infringement thereof at least as early as March 31, 2016, when Mr. Chuck Hausmann, Esq., on behalf of Plaintiff, sent a letter to Ms. Kathryn Tsigotis, Director of Licensing for Lenovo USA, disclosing the '234 patent and other of Plaintiff's patents and alleging that Defendants' products infringed the '234 patent, among others.

124. Upon information and belief, since at least the time Defendants received notice, Defendants have induced and continue to induce others to infringe at least one claim of the '234 patent under 35 U.S.C. § 271(b) by, among other things, and with specific intent or willful blindness, actively aiding and abetting others to infringe, including but not limited to Defendants' partners, clients, customers, and end users, whose use of the Accused Instrumentalities constitutes direct infringement of at least one claim of the '234 patent.

125. In particular, Defendants' actions that aid and abet others such as its partners, customers, clients, and end users to infringe include advertising and distributing the Accused Instrumentalities and providing instruction materials, training, and services regarding the Accused Instrumentalities. On information and belief, Defendants have engaged in such actions with specific intent to cause infringement or with willful blindness to the resulting infringement because Defendants have had actual knowledge of the '234 patent and knowledge that its acts were inducing infringement of the '234 patent since at least March 31, 2016.

126. Upon information and belief, Defendants are liable as contributory infringers of the '234 patent under 35 U.S.C. § 271(c) by offering to sell, selling and importing into the United States components to be especially made or adapted for use in an infringement of the '234 patent. The Accused Instrumentalities are a material component for use in practicing the '234 patent and are specifically made and are not a staple article of commerce suitable for substantial non-infringing use.

127. Since March 31, 2016, Defendants' infringement has been willful.

128. Plaintiff has been harmed by Defendants' infringing activities.

COUNT VIII – INFRINGEMENT OF U.S. PATENT NO. 7,873,389

129. The allegations set forth in the foregoing paragraphs 1 through 128 are incorporated into this Eighth Claim for Relief.

130. On January 18, 2011, U.S. Patent No. 7,873,389 ("the '389 patent"), entitled "Radio Base Station Apparatus, Radio Terminal Apparatus, Mobile Communications System, and Reception Operation Control Program," was duly and legally issued by the United States Patent and Trademark Office. A true and correct copy of the '389 patent is attached as Exhibit 8.

131. Plaintiff is the assignee and owner of the right, title and interest in and to the '389 patent, including the right to assert all causes of action arising under said patents and the right to any remedies for infringement of them.

132. Upon information and belief, Defendants have and continue to directly infringe at least claim 1 of the '389 patent by making, using, selling, importing and/or providing and causing to be used the Accused Instrumentalities, as defined above.

133. In particular, claim 1 of the '389 patent recites a communication method comprising: receiving a connection request from a radio terminal apparatus; and transmitting a multiple-field frame to the radio terminal apparatus which has sent the connection request, wherein (1) a single bit indicating a reception operation adapted to a transmission operation of a radio base station apparatus and (2) data are respectively contained in mutually different fields of the multiple-field frame.

134. On information and belief, the Accused Instrumentalities infringe claim 1 of the '234 patent because they comply with IEEE Standard 802.11n-2009, which recommends a communication method between a radio base station apparatus ("access point" or "AP" below) and a radio terminal apparatus ("STA" below) comprising: receiving a connection request from the radio terminal apparatus:

IEEE Std. 802.11-2007

11.3.2.2 AP association procedures

When an Association Request frame is received from a STA, the AP shall associate with the STA using the following procedure . . .

IEEE Std. 802.11n-2009

11.3.2.2 AP association procedures

Insert the following list items (b2 and b3) after item b1) in 11.3.2.2 as follows:

- b2) An AP shall refuse an association request from a STA that does not support all the rates in the BSSBasicRateSet parameter.
- b3) An AP shall refuse an association request from an HT STA that does not support all the MCSs in the BSSBasicMCSSet parameter.

and transmitting a multiple-field frame to the radio terminal apparatus which has sent the connection request, wherein (1) a single bit indicating a reception operation adapted to a transmission operation of a radio base station apparatus:

The AP includes a transmitter for transmitting the HT-mixed format PPDU (multiple-field frame) to the STA that sent the association request frame. As shown below in Table 20-11—HT-SIG fields, a single bit within the HT-SIG field indicates smoothing, which is a reception operation adapted to a transmission operation of the radio base station apparatus (STA).

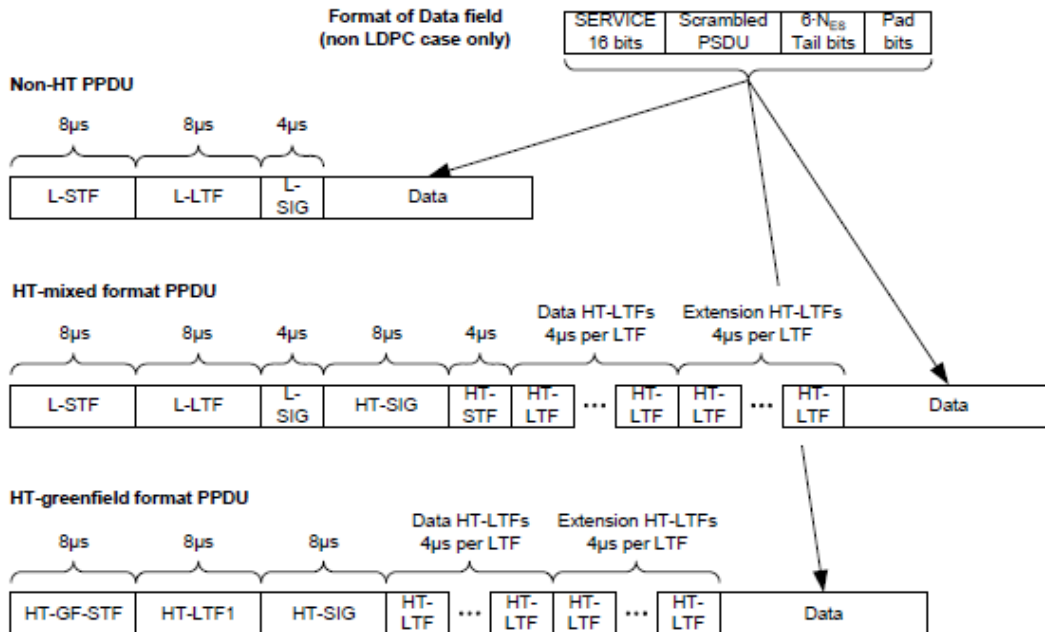

Figure 20-1—PPDU format

Table 20-10—HT-SIG fields (continued)

Field	Number of bits	Explanation and coding
Smoothing	1	Set to 1 indicates that channel estimate smoothing is recommended. Set to 0 indicates that only per-carrier independent (unsmoothed) channel estimate is recommended. See 20.3.11.10.1.

and (2) data are respectively contained in mutually different fields of the multiple-field frame:

The single bit indicating smoothing within the HT-SIG field and Data are respectively contained in mutually different fields of the HT-mixed format PPDU, as shown in Figure 20-1 below.

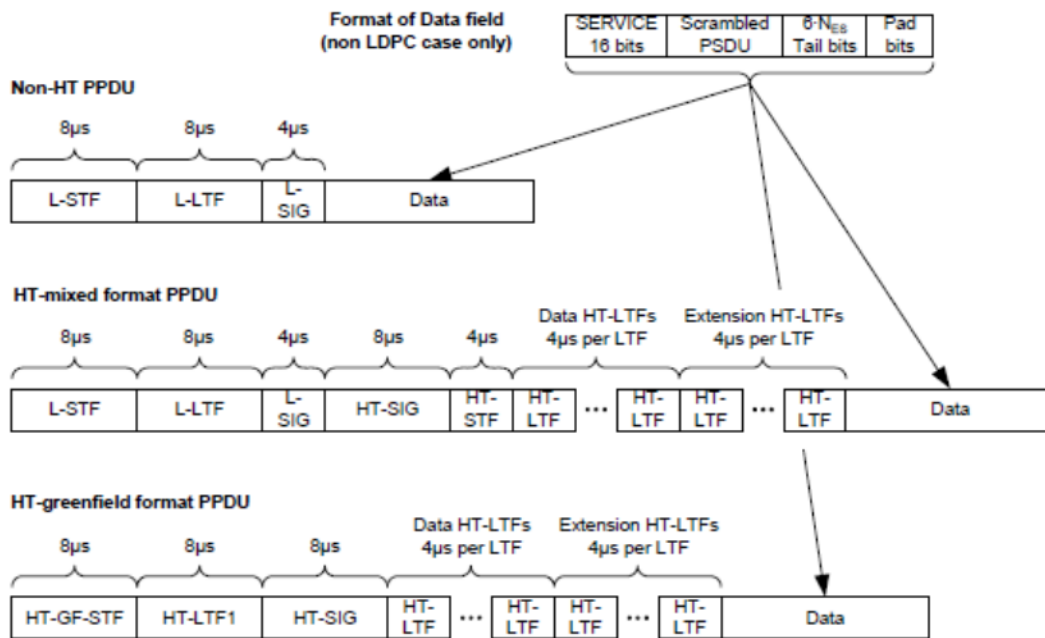

Figure 20-1—PPDU format

135. On information and belief, these Accused Instrumentalities are used, marketed, provided to, and/or used by or for each of Defendants’ partners, clients, customers and end users across the country and in this District.

136. Defendants were made aware of the ’389 patent and their infringement thereof at least as early as March 31, 2016, when Mr. Chuck Hausmann, Esq., on behalf of Plaintiff, sent a

letter to Ms. Kathryn Tsirigotis, Director of Licensing for Lenovo USA, disclosing the '389 patent and other of Plaintiff's patents and alleging that Defendants' products infringed the '389 patent, among others.

137. Upon information and belief, since at least the time Defendants received notice, Defendants have induced and continue to induce others to infringe at least one claim of the '389 patent under 35 U.S.C. § 271(b) by, among other things, and with specific intent or willful blindness, actively aiding and abetting others to infringe, including but not limited to Defendants' partners, clients, customers, and end users, whose use of the Accused Instrumentalities constitutes direct infringement of at least one claim of the '389 patent.

138. In particular, Defendants' actions that aid and abet others such as its partners, customers, clients, and end users to infringe include advertising and distributing the Accused Instrumentalities and providing instruction materials, training, and services regarding the Accused Instrumentalities. On information and belief, Defendants have engaged in such actions with specific intent to cause infringement or with willful blindness to the resulting infringement because Defendants have had actual knowledge of the '389 patent and knowledge that its acts were inducing infringement of the '389 patent since at least March 31, 2016.

139. Upon information and belief, Defendants are liable as contributory infringers of the '389 patent under 35 U.S.C. § 271(c) by offering to sell, selling and importing into the United States components to be especially made or adapted for use in an infringement of the '389 patent. The Accused Instrumentalities are a material component for use in practicing the '389 patent and are specifically made and are not a staple article of commerce suitable for substantial non-infringing use.

140. Since March 31, 2016, Defendants' infringement has been willful.

141. Plaintiff has been harmed by Defendants' infringing activities.

COUNT IX – INFRINGEMENT OF U.S. PATENT NO. 8,737,377

142. The allegations set forth in the foregoing paragraphs 1 through 141 are incorporated into this Ninth Claim for Relief.

143. On May 27, 2014, U.S. Patent No. 8,737,377 ("the '377 patent"), entitled "Radio Apparatus," was duly and legally issued by the United States Patent and Trademark Office. A true and correct copy of the '377 patent is attached as Exhibit 9.

144. Plaintiff is the assignee and owner of the right, title and interest in and to the '377 patent, including the right to assert all causes of action arising under said patents and the right to any remedies for infringement of them.

145. Upon information and belief, Defendants have and continue to directly infringe at least claims 1 and 2 of the '377 patent by making, using, selling, importing and/or providing and causing to be used the Accused Instrumentalities, as defined above.

146. In particular, claim 1 of the '377 patent recites a transmitting apparatus comprising: a generation unit configured to generate a packet signal including a plurality of CDD (Cyclic Delay Diversity) applied streams; and a radio unit configured to send the packet signal from a plurality of antennas, wherein the generation unit includes in the packet signal, information permitting a receiving apparatus to perform a smoothing process of channel coefficients across subcarriers when an amount of shift for CDD for the packet signal to be sent from the plurality of antennas becomes smaller than a threshold value defined for time, otherwise prohibiting the receiving apparatus to perform the smoothing process, wherein the generation unit generates a packet signal in which a legacy short training field (L-STF), a legacy long training field (L-LTF), a legacy signal field L-SIG), a high throughput signal field (HT-SIG), a high throughput short training field (HT-STF), multiple high throughput long training fields

(HT-LTF), and data are assigned in the stated order and the information is included in the high throughput short training field (HT-SIG).

147. On information and belief, the Accused Instrumentalities infringe claim 1 of the '377 patent because they comply with IEEE Standard 802.11n-2009, which recommends a transmitting apparatus comprising: a generation unit configured to generate a packet signal (e.g., an HT-mixed format signal) including a plurality of CDD (Cyclic Delay Diversity) applied streams:

IEEE Std. 802.11n-2009

3A. Definitions specific to IEEE 802.11

3A.22 high-throughput-mixed (HT-mixed) format: A physical layer convergence procedure (PLCP) protocol data unit (PPDU) format of the HT physical layer (PHY) using the HT-mixed format preamble.

20.3.3 Transmitter block diagram

HT-mixed format and HT-greenfield format transmissions can be generated using a transmitter [...]

[...]

j) Cyclic shift (CSD) insertion is where the insertion of the cyclic shifts prevents unintentional beamforming. CSD insertion may occur before or after the IDFT.

[...]

a radio unit configured to send the packet signal from a plurality of antennas:

IEEE Std. 802.11n-2009

20.3.9 HT preamble

20.3.9.1 Introduction

The HT preambles are defined in HT-mixed format and in HT-greenfield format to carry the required information to operate in a system with multiple transmit and multiple receive antennas.

wherein the generation unit includes in the packet signal, information permitting a receiving apparatus to perform a smoothing process of channel coefficients across subcarriers when an amount of shift for CDD for the packet signal to be sent from the plurality of antennas becomes

smaller than a threshold value defined for time, otherwise prohibiting the receiving apparatus to perform the smoothing process:

The HT-SIG field of the HT-mixed format packet signal includes information (a bit) permitting a receiving apparatus to perform a smoothing process when the value of the Q_k matrix = 1 (the identity matrix) and the amount of shift for CDD for the packet signal becomes smaller than a threshold value, as demonstrated below in Table 20-10—HT SIG fields and in section 20.3.11.10.1 of the standard.

IEEE Std. 802.11n-2009

Table 20-10—HT-SIG fields

Field	Number of bits	Explanation and coding
Smoothing	1	Set to 1 indicates that channel estimate smoothing is recommended. Set to 0 indicates that only per-carrier independent (unsmoothed) channel estimate is recommended. See 20.3.11.10.1.

20.3.11.10.1 Spatial mapping

If 95% of the sum of the energy from all impulse responses of the time domain channels between all spacetime streams and all transmit chain inputs, induced by the CSD added according to Table 20-9 and the frequency-dependence in the matrix, is contained within 800 ns, the smoothing bit should be set to 1.

Otherwise, it shall be set to 0.

wherein the generation unit generates a packet signal in which a legacy short training field (L-STF), a legacy long training field (L-LTF), a legacy signal field L-SIG), a high throughput signal field (HT-SIG), a high throughput short training field (HT-STF), multiple high throughput long training fields (HT-LTF), and data are assigned in the stated order

IEEE Std. 802.11n-2009

3A. Definitions specific to IEEE 802.11

3A.22 high-throughput-mixed (HT-mixed) format: A physical layer convergence procedure (PLCP) protocol data unit (PPDU) format of the HT physical layer (PHY) using the HT-mixed format preamble.

20.3.3 Transmitter block diagram

HT-mixed format and HT-greenfield format transmissions can be generated using a transmitter [...]

20.3.2 PPDU format

Two formats are defined for the PLCP: HT-mixed format and HT-greenfield format. These two formats are called *HT formats*. Figure 20-1 shows the non-HT format¹ and the HT formats. [...]

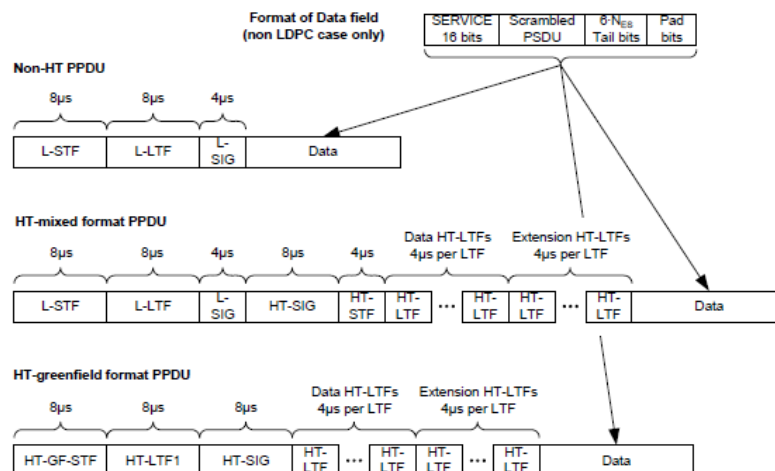

Figure 20-1—PPDU format

The elements of the PLCP packet are summarized in Table 20-4.

Table 20-4—Elements of the HT PLCP packet

Element	Description
L-STF	Non-HT Short Training field
L-LTF	Non-HT Long Training field
L-SIG	Non-HT SIGNAL field
HT-SIG	HT SIGNAL field
HT-STF	HT Short Training field
HT-GF-STF	HT-Greenfield Short Training field
HT-LTF1	First HT Long Training field (Data)
HT-LTFs	Additional HT Long Training fields (Data and Extension)
Data	The Data field includes the PSDU

20.3.9.2 HT-mixed format preamble

In HT-mixed format frames, the preamble has fields that support compatibility with Clause 17 and Clause 19 STAs and fields that support HT operation. The non-HT portion of the HT-mixed format preamble enables detection of the PPDU and acquisition of carrier frequency and timing by both HT STAs and STAs that are compliant with Clause 17 or Clause 19. [...] The HT portion of the HT-mixed format preamble enables estimation of the MIMO channel to support demodulation of the data portion of the frame by HT STAs.

20.3.9.3.3 L-STF definition

The L-STF is identical to the Clause 17 short training symbol.

20.3.9.3.4 L-LTF definition

The non-HT long training OFDM symbol is identical to the Clause 17 long training OFDM symbol.

20.3.9.3.5 L-SIG definition

The L-SIG is used to communicate rate and length information.

20.3.9.4.3 HT-SIG definition

The HT-SIG is used to carry information required to interpret the HT packet formats.

20.3.9.4.5 HT-STF definition

The purpose of the HT-STF is to improve automatic gain control estimation in a MIMO system.

20.3.9.4.6 HT-LTF definition

The HT-LTF provides a means for the receiver to estimate the MIMO channel between the set of QAM mapper outputs (or, if STBC is applied, the STBC encoder outputs) and the receive chains.

and the information is included in the high throughput short training field (HT-SIG):

IEEE Std. 802.11n-2009

Table 20-10—HT-SIG fields

Field	Number of bits	Explanation and coding
Smoothing	1	Set to 1 indicates that channel estimate smoothing is recommended. Set to 0 indicates that only per-carrier independent (unsmoothed) channel estimate is recommended. See 20.3.11.10.1.

148. Claim 2 of the '377 patent recites the transmitting apparatus according to claim 1, further comprising a transmission unit configured to transmit the packet signal generated in the generation unit from a plurality of antennas.

149. On information and belief, the Accused Instrumentalities infringe claim 2 of the '377 patent because they infringe claim 1, as demonstrated in paragraph 147 above, and because they comply with IEEE Standard 802.11n-2009, which recommends a transmitting apparatus

further comprising a transmission unit configured to transmit the packet signal generated in the generation unit from a plurality of antennas:

IEEE Std. 802.11n-2009

20.3.9 HT preamble

20.3.9.1 Introduction

The HT preambles are defined in HT-mixed format and in HT-greenfield format to carry the required information to operate in a system with multiple transmit and multiple receive antennas.

150. On information and belief, these Accused Instrumentalities are used, marketed, provided to, and/or used by or for each of Defendants' partners, clients, customers and end users across the country and in this District.

151. Defendants were made aware of the '377 patent and their infringement thereof at least as early as March 31, 2016, when Mr. Chuck Hausmann, Esq., on behalf of Plaintiff, sent a letter to Ms. Kathryn Tsirigotis, Director of Licensing for Lenovo USA, disclosing the '377 patent and other of Plaintiff's patents and alleging that Defendants' products infringed the '377 patent, among others.

152. Upon information and belief, since at least the time Defendants received notice, Defendants have induced and continue to induce others to infringe at least one claim of the '377 patent under 35 U.S.C. § 271(b) by, among other things, and with specific intent or willful blindness, actively aiding and abetting others to infringe, including but not limited to Defendants' partners, clients, customers, and end users, whose use of the Accused Instrumentalities constitutes direct infringement of at least one claim of the '377 patent.

153. In particular, Defendants' actions that aid and abet others such as its partners, customers, clients, and end users to infringe include advertising and distributing the Accused Instrumentalities and providing instruction materials, training, and services regarding the

Accused Instrumentalities. On information and belief, Defendants have engaged in such actions with specific intent to cause infringement or with willful blindness to the resulting infringement because Defendants have had actual knowledge of the '377 patent and knowledge that its acts were inducing infringement of the '377 patent since at least March 31, 2016.

154. Upon information and belief, Defendants are liable as contributory infringers of the '377 patent under 35 U.S.C. § 271(c) by offering to sell, selling and importing into the United States components to be especially made or adapted for use in an infringement of the '377 patent. The Accused Instrumentalities are a material component for use in practicing the '377 patent and are specifically made and are not a staple article of commerce suitable for substantial non-infringing use.

155. Since March 31, 2016, Defendants' infringement has been willful.

156. Plaintiff has been harmed by Defendants' infringing activities.

STATEMENT REGARDING RAND OBLIGATION

157. Plaintiffs contend that, pursuant to relevant IEEE bylaws, the '103, '115, '851, '024, '400, '878, '234, '389, and '377 patents are subject to Reasonable and Non-Discriminatory ("RAND") licensing obligations to willing licensees.

158. As of the time of this complaint, over sixty companies have taken a license to one or more of the '103, '115, '851, '024, '400, '878, '234, '389, and '377 patents.

159. Despite notice of their infringement, Defendants have refused to license the '103, '115, '851, '024, '400, '878, '234, '389, and '377 patents willingly. Accordingly, Defendants should be treated as an unwilling licensees, so that Plaintiffs are not bound by any RAND licensing obligation for purposes of this action or any license to Defendants. Accordingly,

Plaintiffs seek the maximum available reasonable royalty damages to compensate for Defendants' infringing activities.

JURY DEMAND

Pursuant to Rule 38 of the Federal Rules of Civil Procedure, Plaintiffs demand a trial by jury on all issues triable as such.

PRAYER FOR RELIEF

WHEREFORE, Plaintiffs demand judgment for itself and against Defendants as follows:

- A. An adjudication that Defendants have infringed the '103, '115, '851, '024, '400, '878, '234, '389, and '377 patents;
- B. An award of damages to be paid by Defendants adequate to compensate Plaintiffs for Defendants' past infringement of the '103, '115, '851, '024, '400, '878, '234, '389, and '377 patents, and any continuing or future infringement through the date such judgment is entered, including interest, costs, expenses and an accounting of all infringing acts including, but not limited to, those acts not presented at trial;
- C. A declaration that this case is exceptional under 35 U.S.C. § 285, and an award of Plaintiffs' reasonable attorneys' fees; and
- D. An award to Plaintiffs of such further relief at law or in equity as the Court deems just and proper.

Dated: September 5, 2017

DEVLIN LAW FIRM LLC

/s/ Timothy Devlin

Timothy Devlin (#4241)

tdevlin@devlinlawfirm.com

1306 N. Broom St., 1st Floor

Wilmington, Delaware 19806

Telephone: (302) 449-9010

Facsimile: (302) 353-4251

Attorneys for Plaintiff

HERA WIRELESS S.A. and SISVEL UK LIMITED