

**IN THE UNITED STATES DISTRICT COURT
FOR THE NORTHERN DISTRICT OF TEXAS
DALLAS DIVISION**

POPSOCKETS LLC)	
)	
Plaintiff,)	Case No. 3:17-CV-2398
)	
v.)	
)	
DIGITAL METRO USA, INC. D/B/A)	JURY TRIAL DEMANDED
WIRELESS STOP and AKBAR TEJANI)	
)	
Defendants.)	
)	

COMPLAINT FOR PATENT, COPYRIGHT, AND TRADEMARK INFRINGEMENT

Plaintiff, PopSockets LLC (“PopSockets”), by and through its undersigned attorneys, for its Complaint for Patent, Copyright, and Trademark Infringement against Defendants Digital Metro USA, Inc. d/b/a Wireless Stop (“Digital Metro”) and Akbar Tejani (“Tejani”) (collectively, “Defendants”), hereby alleges:

INTRODUCTION

1. PopSockets is one of the nation’s leading providers of grips and mount accessories for handheld electronic devices as well as the exclusive provider of award-winning and innovative POPSOCKET brand products and its products are, and for approximately five years have been, sold in stores and online throughout the country.

2. Digital Metro was incorporated in 2013 in the State of Texas.

3. Tejani is and has been the President of Digital Metro. On information and belief, Defendants have made unauthorized use of PopSockets’ patented technology by importing, making, using, selling, and/or offering for sale products that, but for inferior materials,

construction, and operation, are nearly identical to the collapsible socket and mount products covered by PopSockets' patents.

4. On information and belief, Defendants copied PopSockets' registered works of art from PopSockets' product packaging and/or PopSockets' websites, and/or those websites of PopSockets authorized resellers, and used these works of art to create identical, or strikingly or substantially similar versions of these works of art.

5. On information and belief, Defendants copied PopSockets' trademark from products and /or PopSockets' websites, and/or those websites of PopSockets' authorized resellers and now use a confusingly similar mark in connection with Defendants' products.

NATURE OF THE CASE

6. This action arises under the patent laws of the United States, 35 U.S.C. § 271 for Defendants' infringement of U.S. Patent No. 8,560,031 (the "'031" Patent) and U.S. Design Patent No. D777,022 ("the '022 Patent"), under the Copyright Act, 17 U.S.C. § 101 for Defendants' unlawful copying of PopSockets' registered works of art, and under the Lanham Act, 15 U.S.C. § 1125(a), and the laws of the State of Texas for Defendants' unlawful use of PopSockets' trademark.

PARTIES

7. PopSockets is a corporation organized under the laws of Colorado with its corporate headquarters and principle place of business at 3033 Sterling Circle, Boulder, Colorado 80301.

8. Digital Metro is a corporation organized under the laws of Texas with a brick-and-mortar store located at 11536 Harry Hines Road, Dallas, Texas 76039 and a registered-agent address of 1502 Alberi Drive, Euless, Texas 76039.

9. Tejani is and has been the President of Digital Metro, and resides at 1502 Alberi Drive, Euless, Texas 76039.

JURISDICTION AND VENUE

10. The action arises under the patent laws of the United States, 35 U.S.C. § 271 *et seq.*, the copyright laws of the United States 17 U.S.C. § 101 *et seq.*, the Lanham Act, 15 U.S.C. § 1125(a), and the laws of the State of Texas. The Court has subject matter jurisdiction under 28 U.S.C. §§ 1331, 1338, and 1367(a).

11. Venue is proper in this Court pursuant to 28 U.S.C. §§ 1391(b) and (c) and 1400(b) because Defendants reside in this District as well as have committed acts of infringement in this District and have a regular and established place of business in this District.

12. Personal jurisdiction exists over Defendants at least because: (1) Defendants are incorporated and have their principal places of business, or otherwise reside in this District, (2) Defendants have a regular and established place of business in this District and regularly conduct business throughout this State, and (3) Defendants have committed, and continue to commit acts of patent, copyright, and trademark infringement, and/or induced acts of patent, copyright, and trademark infringement by others, in this District and throughout this State.

FACTUAL BACKGROUND **The 8,560,031 Patent**

13. PopSockets is the assignee, and the sole and exclusive owner of all right, title, and interest in the '031 Patent, entitled "Extending Socket for Portable Media Player." The '031 Patent was duly and legally issued by the United States Patent and Trademark Office on October 15, 2013. A copy of the '031 Patent is attached hereto as Exhibit A.

14. Mr. Barnett, named inventor of the inventions claimed in the '031 Patent, is the CEO of PopSockets.

15. PopSockets has been producing its collapsible socket product since 2012. PopSockets' collapsible socket product is well-known nationwide, sold online, and carried in retail stores throughout the country such as Target and Best Buy.

16. Since its inception, PopSockets has been recognized and touted by major media outlets. In 2012, National Public Radio (NPR) recognized PopSockets' innovativeness. The Wall Street Journal identified PopSockets' collapsible socket product as the "best" compact "smartphone support" accessory in 2015. USA Today named PopSockets "the coolest tech you have to see" in 2015. PopSockets won the "Fueling Innovation" contest sponsored by Mercedes Benz in 2013, was featured at the 2015 Consumer Electronics Show, and was the first recipient of Kate Galliet's "Fit For Real Life Seal of Approval" award in 2016.

17. PopSockets' collapsible socket product can be used in a variety of different ways. For example, consumers can use PopSockets' collapsible socket as a grip for taking pictures, as a stand to prop up a mobile device, or to ease a consumer's texting, scrolling, or other common portable media player device uses.

18. PopSockets allows customers to customize the collapsible sockets with various graphics and designs. PopSockets currently sells over 120 different decorative designs with various base and accordion colors. In addition, users can upload graphics or images to customize the collapsible socket product.

19. To the extent required by law, PopSockets has complied with the provisions of 35 U.S.C. § 287.

20. Defendants' socket product ("Accused Product") is marketed as an "Anti drop smartphone grip / stand / wrap."

21. On information and belief, Defendants are responsible for importing, making, using, selling, and offering for sale the Accused Product.

22. Defendants continue to import, make, use, sell, and offer for sale the Accused Product in its physical store and previously sold the Accused Product on its website.

23. Some of the Accused Products sold by Defendants incorporate aesthetic designs and graphics that closely resemble those used on PopSockets' products.

24. Each Defendant has infringed, is currently infringing, and unless enjoined, will continue to infringe at least claims 9 and 16 of the '031 Patent in this District and elsewhere in the United States by importing, making, using, selling, and/or offering for sale the Accused Product which embodies each claimed element:



A

B

C

a. a securing element for attaching the socket to the back of a portable media player or player case and an accordion forming a tapered shape connected to the securing element, as illustrated in figures B and C above.

b. an accordion that is capable of extending outward generally along its axis from the portable media player or player case and retracting back toward the portable media player or player case by collapsing generally along its axis, as illustrated in figures A, B, and C above.

25. Examples of Defendants' infringement of claim 16 include performing the claimed method steps of:

- a. attaching a socket including the accordion to a portable media player or player case, as shown in figure C above.
- b. selectively extending the socket by unfolding the accordion generally along its axis, as shown in figure B above.
- c. selectively retracting the socket by folding the accordion generally along its axis such that the walls fold next to each other, as shown in figure A.



The D777,022 Design Patent

26. PopSockets is the assignee, and the sole and exclusive owner of all right, title, and interest in the '022 Patent, entitled "Device Clip." The '022 Patent was duly and legally issued by the United States Patent and Trademark Office on January 24, 2017. A copy of the '022 Patent is attached hereto as Exhibit B.

27. Mr. Barnett, named inventor of the inventions claimed in the '022 Patent, is currently the CEO of PopSockets.

28. PopSockets product covered by the '022 Patent is a mount for a PopSockets' collapsible socket.

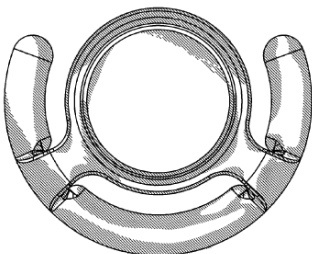
29. Defendants' infringing clip product ("Accused Clip Product") is virtually identical to the '022 Patent.

PopSockets' '022 Patent	Defendants' Accused Clip Product
 A technical line drawing of a circular device with a central ring and two side flaps, shown in a perspective view.	 A photograph of a white, circular plastic device with a central ring and two side flaps, matching the design in the patent drawing.

Defendants’ Unauthorized Use of PopSockets’ Works of Art

30. PopSockets holds and owns the copyrights in the works of art, attached hereto as Exhibit C (“Works of Art”), that were unlawfully copied by Defendants. *See* Reg. Nos. VA2058815; VA2058466; VA2058463.

31. PopSockets’ and/or PopSockets’ authorized resellers’ website(s) and product packaging contain illustrations of its collapsible socket product, including the graphics copied by Defendants.

32. On information and belief, in their promotion of the Accused Product, and without permission or authorization from PopSockets, Defendants copied and used, and continues to use, at least three Works of Art, shown below, that are either identical or strikingly or substantially similar to graphics displayed on PopSockets’ and/or PopSockets’ authorized resellers’ website(s) and product packaging.

PopSockets’ Registered Works of Art	Defendants’ Use of Works of Art
	



Defendants’ Unauthorized Use of PopSockets’ Trademark

33. PopSockets owns a federal trademark registration and application that includes PopSockets’ design mark. *See* U.S. Registration No. 5204637; U.S. Serial No. 87321001.

34. PopSockets is the owner of and has common law rights in the trademark shown below (the “Design Mark”). A use-based application for the Design Mark (Serial No. 87,321,001) is pending with the U.S. Patent and Trademark Office.

35. PopSockets has used the Design Mark since at least as early as 2014.

36. The Design Mark has been continuously used on PopSockets’ mount product embodied in the ’022 Patent prior to Defendants’ use and dissemination of the confusingly similar mark shown below.

PopSockets’ Design Mark	Defendants’ Use of the Design Mark
	

37. PopSockets has used and continues to use the Design Mark on its websites, product packaging, product displays, trade dress, advertisements, and social media pages. For example, see PopSockets’ Twitter, Facebook, Instagram, and Pinterest pages and product packaging reproduced below.

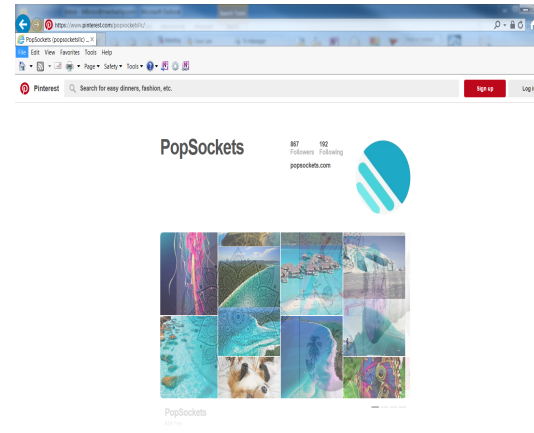
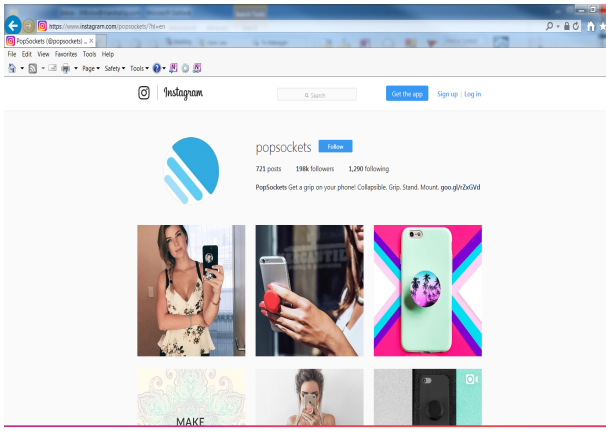
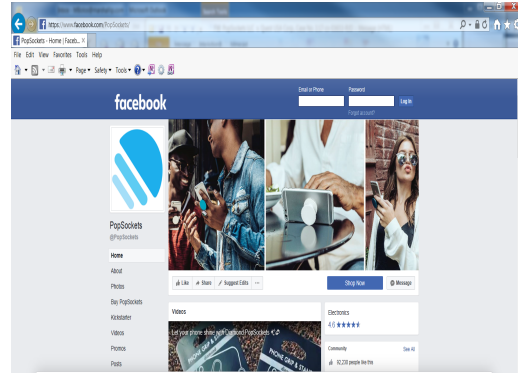
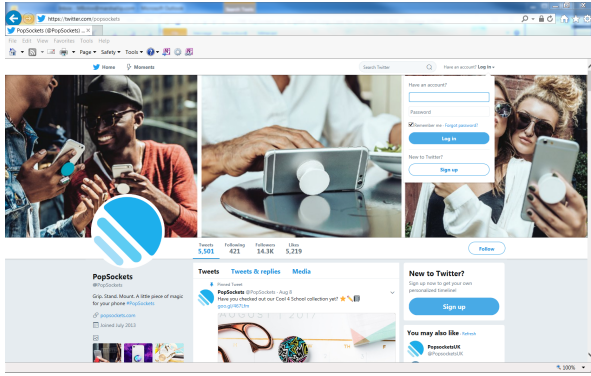

38. As a result of PopSockets' marketing and advertising efforts, the Design Mark serves as a source identifier for PopSockets' products.

39. Without PopSockets' permission or authorization, Defendants use PopSockets' Design Mark and sell products that include the Design Mark.

40. On information and belief, at the time Defendants began making, using, importing, selling and/or offering for sale products that bear that Design Mark, they had actual knowledge, or should have known, of PopSockets' use of the Design Mark.

41. Defendants' use of an identical or confusingly similar variation of the Design Mark creates a likelihood of confusion as to the source of the Defendants' products.

Relationship Between the Defendants

42. On information and belief, Tejani has operated Digital Metro since the company's inception.

43. Tejani is the registered agent and President of Digital Metro.

44. Digital Metro and Tejani share the same address.

COUNT ONE INFRINGEMENT OF THE '031 PATENT BY DIGITAL METRO

45. PopSockets hereby incorporates the allegations of paragraphs 1 through 44 of this Complaint as if fully set forth herein.

46. Digital Metro has infringed, is currently infringing, and unless enjoined, will continue to infringe at least claims 9 and 16 of the '031 Patent.

47. Digital Metro has directly infringed and continues to directly infringe the '031 Patent by importing, making, using, selling, and/or offering for sale the Accused Product.

48. On information and belief, Digital Metro has willfully infringed and continues to willfully infringe the '031 Patent despite knowledge of the '031 Patent (at least as of the date of the filing of this Complaint, PopSockets' website(s), and through PopSockets' patent markings) and despite an objectively high likelihood that the sale and use of the Accused Product would infringe one or more claims of the '031 Patent. Digital Metro's knowledge of the '031 Patent and its claimed inventions is further evidenced by Digital Metro's copying and use of Works of

Art from PopSockets' website and product packaging that depict PopSockets' collapsible socket product embodying the claimed inventions.

49. On information and belief, Digital Metro indirectly infringes one or more claims of the '031 Patent by inducing its customers' infringement through the use of the Accused Product. On information and belief, Digital Metro knew or should have known that its acts would result in the actual infringement of one or more of the claims of the '031 Patent by one or more of its customers and thereby intended such infringement.

50. Digital Metro's acts did, in fact, induce such infringement of one or more claims of the '031 Patent by instructing and encouraging these persons, by means of packaging, promotional and instructional guides, and/or physical demonstration, to use the Accused Product in a manner that infringed the '031 Patent. By following these instructions, Digital Metro's customers have directly infringed and continue to directly infringe at least claims 9 and 16 of the '031 Patent.

51. As a direct and proximate consequence of Digital Metro's infringement of the '031 Patent, PopSockets has suffered and will continue to suffer irreparable injury and damages in an amount that an award of money would never be adequate to fully remedy, for which PopSockets is entitled to relief. PopSockets seeks damages, as well as injunctive relief against further infringement.

COUNT TWO
INFRINGEMENT OF THE '031 PATENT BY TEJANI

52. PopSockets hereby incorporates the allegations of paragraphs 1 through 51 of this Complaint as if fully set forth herein.

53. On information and belief, Tejani actively assisted, and continues to assist, with Digital Metro's infringement of the '031 Patent and is liable for inducing infringement.

54. On information and belief, as the President of Digital Metro, Tejani is directly responsible for the day-to-day operations of Digital Metro and had knowledge of PopSockets' patented technologies and the '031 Patent (at least as of the date of the filing of this Complaint, and through PopSockets' website(s), and/or patent markings). Despite such knowledge and awareness, on information and belief, Tejani intentionally directed Digital Metro to perform the actions giving rise to Digital Metro's infringement of the '031 Patent.

COUNT THREE
INFRINGEMENT OF THE '022 DESIGN PATENT BY DIGITAL METRO

55. PopSockets hereby incorporates the allegations of paragraphs 1 through 54 of this Complaint as if fully set forth herein.

56. Digital Metro has infringed and continues to infringe the '022 design patent by importing, making, using, selling, and/or offering for sale the Accused Clip Product.

57. An ordinary observer, giving such attention as a purchaser usually gives, would be so deceived by the resemblance between the design of the Accused Clip Product and the '022 Patent as to be induced to purchase the Accused Clip Product believing it embodies the design(s) of the '022 Patent.

58. Digital Metro's deliberate and willful actions in infringing the design(s) of the '022 Patent have caused and will continue to cause irreparable harm to PopSockets unless preliminarily and permanently enjoined pursuant to 35 U.S.C. § 283.

59. Digital Metro has profited from and PopSockets has suffered damages as a result of Digital Metro's infringement of the '022 Patent.

**COUNT FOUR
INFRINGEMENT OF THE '022 DESIGN PATENT BY TEJANI**

60. PopSockets hereby incorporates the allegations of paragraphs 1 through 59 of this Complaint as if fully set forth herein.

61. On information and belief, Tejani has actively assisted, and continues to assist, with Digital Metro's infringement of the '022 Patent and is liable for inducing infringement.

62. An ordinary observer, giving such attention as a purchaser usually gives, would be so deceived by the resemblance between the design of the Accused Clip Product and the '022 Patent as to be induced to purchase the Accused Clip Product believing it embodies the design(s) of the '022 Patent.

63. On information and belief, as the President of Digital Metro, Tejani is directly responsible for the day-to-day operations of Digital Metro.

64. Tejani's deliberate and willful actions in directing Digital Metro to infringe the design(s) of the '022 Patent have caused and will continue to cause irreparable harm to PopSockets unless preliminarily and permanently enjoined pursuant to 35 U.S.C. § 283.

65. Tejani, as President of Digital Metro, has profited from and PopSockets has suffered damages as a result of Defendants' infringement of the '022 Patent.

**COUNT FIVE
COPYRIGHT INFRINGEMENT BY DIGITAL METRO**

66. PopSockets repeats and incorporates by reference the allegations contained in paragraphs 1 through 65 as if fully set forth herein.

67. PopSockets is the copyright owner of each of the original, published Works of Art contained in Exhibit C. The associated copyright registration certificates for each work are also attached as Exhibit C.

68. Each of the Works of Art contained in Exhibit C is copyrightable subject matter under the laws of the United States.

69. Direct proof of access is not required for strikingly similar works (or identical as the case may be) such as those used by Digital Metro, but even so, Digital Metro had access to the Works of Art through PopSockets' and/or PopSockets' authorized resellers' website(s) and product packaging.

70. Digital Metro has never asked for or been granted permission to use or reproduce the Works of Art.

71. Digital Metro used, and continues to use, graphics that are identical or strikingly or substantially similar to PopSockets' registered Works of Art in its promotion of the Accused Product.

72. Digital Metro copied and reproduced identical or strikingly or substantially similar versions of the Works of Art without PopSockets' consent.

73. Digital Metro engaged, and continues to engage in acts of infringement by using the Works of Art that are identical, or strikingly or substantially similar variations in materials, such as product packaging, distributed to third parties.

74. PopSockets is informed and thereon alleges that Digital Metro further infringed PopSockets' copyrights by making or causing to be made derivative works based on the Works of Art and producing and/or distributing reproductions without PopSockets' permission.

75. Digital Metro's aforesaid acts violate PopSockets' exclusive rights under section 106 of the Copyright Act and constitute copyright infringement.

76. PopSockets is entitled to injunctive relief prohibiting Digital Metro's further infringement.

**COUNT SIX
COPYRIGHT INFRINGEMENT BY TEJANI**

77. PopSockets repeats and incorporates by reference the allegations contained in paragraphs 1 through 76 as if fully set forth herein.

78. PopSockets is the copyright owner of each of the original, published Works of Art contained in Exhibit C. The associated copyright registration certificates for each work are also attached as Exhibit C.

79. Each of the Works of Art contained in Exhibit C is copyrightable subject matter under the laws of the United States.

80. Direct proof of access is not required for strikingly similar works (or identical as the case may be) such as those used by Digital Metro, but even so, Tejani had access to the Works of Art through PopSockets' and/or PopSockets' authorized resellers' website(s) and product packaging.

81. PopSockets is informed and thereon alleges that Tejani infringed PopSockets' copyrights by making or causing to be made derivative works based on the Works of Art and producing and distributing reproductions without PopSockets' permission.

82. On information and belief, as the President of Digital Metro, Tejani is directly responsible for the day-to-day operations of Digital Metro, and Tejani willfully, knowingly, and personally participated in and directed all of the infringing activities undertaken by Digital Metro.

83. On information and belief, Tejani instructed and induced Digital Metro to use the infringing Works of Art which led to the infringing uses, and therefore Tejani engaged in contributory copyright infringement.

84. Tejani's aforementioned acts violate PopSockets' exclusive rights under section 106 of the Copyright Act and constitute copyright infringement.

85. In the alternative, Tejani has or has had a direct financial interest in the creation, publication, and distribution of the infringing Works of Art, and has had the power or ability to supervise and control the creation, publication, and distribution of the infringing Works of Art, but failed to prevent the infringement of PopSockets' copyrights. Tejani is therefore liable for vicarious infringement of PopSockets' copyrights by Digital Metro.

86. PopSockets is entitled to injunctive relief prohibiting Tejani's further infringement.

**COUNT SEVEN
FEDERAL UNFAIR COMPETITION AND FALSE DESIGNATION OF ORIGIN BY
DIGITAL METRO**

87. PopSockets repeats and incorporates by reference the allegations contained in paragraphs 1 through 86 as if fully set forth herein.

88. Section 43(a) of the Lanham Act, 15 U.S.C. § 1125(a), provides in pertinent part that "[a]ny person who, on or in connection with any goods or services . . . uses in commerce any word, term, name, symbol . . . or any false designation of origin . . . which is likely to cause confusion or to cause mistake, or to deceive as to affiliation . . . or as to origin, sponsorship, or approval of goods [or] services . . . shall be liable in a civil action."

89. Digital Metro's use of the PopSockets' Design Mark is likely to cause confusion, deception, or mistake by creating the false and misleading impression that Digital Metro's business and services are affiliated, connected, or associated with PopSockets.

90. Defendants are passing off their product as those of PopSockets' in a manner that is false, misleading, and misrepresentative of the nature, characteristics, and quality of PopSockets' products.

91. On information and belief, Digital Metro's activities and conduct have been willful and deliberate, knowingly and intentionally designed to tread upon the significant goodwill of PopSockets' trademarks, to cause confusion or mistake, and to deceive the public as to the source or origin of Defendants' goods.

92. Digital Metro's aforementioned acts constitute false designation of origin and trademark infringement in violation of 15 U.S.C. § 1125(a) (Section 43(a) of the Lanham Act).

93. Digital Metro's actions have caused and are likely to cause substantial injury to the public and to PopSockets, its business, goodwill, and reputation.

94. PopSockets is entitled to injunctive relief, and to recover Defendants' profits associated with the infringement and PopSockets' costs.

COUNT EIGHT
FEDERAL UNFAIR COMPETITION AND
FALSE DESIGNATION OF ORIGIN BY TEJANI

95. PopSockets repeats and incorporates by reference the allegations contained in paragraphs 1 through 94 as if fully set forth herein.

96. Section 43(a) of the Lanham Act, 15 U.S.C. § 1125(a), provides in pertinent part that "[a]ny person who, on or in connection with any goods or services . . . uses in commerce any word, term, name, symbol . . . or any false designation of origin . . . which is likely to cause confusion or to cause mistake, or to deceive as to affiliation . . . or as to origin, sponsorship, or approval of goods [or] services . . . shall be liable in a civil action."

97. On information and belief, as the President of Digital Metro, Tejani is directly responsible for the day-to-day operations of Digital Metro, and Tejani willfully, knowingly, and personally participated in and directed all of the infringing activities undertaken by Digital Metro.

98. On information and belief, Tejani instructed and induced Digital Metro to use the infringing Design Mark which led to the infringing uses, and therefore Tejani engaged in trademark infringement.

99. Defendants' use of confusingly similar imitations of PopSockets' Design Mark is likely to cause confusion, deception, or mistake by creating the false and misleading impression that Defendants' business and services are affiliated, connected, or associated with PopSockets.

100. Tejani is passing off Defendants' product as those of PopSockets' in a manner that is false, misleading, and misrepresentative of the nature, characteristics, and quality of PopSockets' products.

101. On information and belief, Tejani's activities and conduct have been willful and deliberate, knowingly and intentionally designed to tread upon the significant goodwill of PopSockets' trademarks, to cause confusion or mistake, and to deceive the public as to the source or origin of Defendants' goods.

102. Tejani's aforementioned acts constitute false designation of origin and trademark infringement in violation of 15 U.S.C. § 1125(a) (Section 43(a) of the Lanham Act).

103. Tejani's actions have caused and are likely to cause substantial injury to the public and to PopSockets, its business, goodwill, and reputation.

104. PopSockets is entitled to injunctive relief, and to recover Defendants' profits associated with the infringement and PopSockets' costs.

**COUNT NINE
COMMON LAW TRADEMARK INFRINGEMENT BY DIGITAL METRO**

105. PopSockets repeats and incorporates by reference the allegations contained in paragraphs 1 through 104 as if fully set forth herein.

106. PopSockets' inherently distinctive Design Mark is extensively used in connection with its products, including the clip product, and PopSockets' use of the Design Mark predates any use by Defendants.

107. Digital Metro's conduct constitutes trademark infringement in violation of Texas common law, and on information and belief, is done willfully with full knowledge of PopSockets' rights in the Design Mark.

108. On information and belief, Defendants have used identical or confusingly similar imitations of PopSockets' Design Mark with the willful and calculated purpose of harming or trading on PopSockets' goodwill and reputation, and in a manner calculated to imply false sponsorship of or approval by PopSockets' for the purpose of misleading and deceiving the public.

109. Digital Metro's acts of common law trademark infringement have damaged and will continue to irreparably damage PopSockets unless enjoined by this Court.

**COUNT TEN
COMMON LAW TRADEMARK INFRINGEMENT BY TEJANI**

110. PopSockets repeats and incorporates by reference the allegations contained in paragraphs 1 through 109 as if fully set forth herein.

111. PopSockets' inherently distinctive Design Mark is extensively used in connection with its products, including the clip product, and PopSockets' use of the Design Mark predates any use by Defendants.

112. On information and belief, as the President of Digital Metro, Tejani is directly responsible for the day-to-day operations of Digital Metro, and Tejani willfully, knowingly, and personally participated in and directed all of the infringing activities undertaken by Digital Metro.

113. On information and belief, Tejani instructed and induced Digital Metro to continue using the mark without permission from PopSockets although Tejani knew or should have known about PopSockets' Design Mark. Therefore Tejani engaged in trademark infringement.

114. Tejani's acts of common law trademark infringement have damaged and will continue to irreparably damage PopSockets unless enjoined by this Court.

COUNT ELEVEN
COMMON LAW UNFAIR COMPETITION BY DIGITAL METRO

115. PopSockets repeats and incorporates by reference the allegations contained in paragraphs 1 through 114 as if fully set forth herein.

116. Digital Metro's use of the Design Mark constitutes unfair competition under Texas common law.

117. Through Defendants' use of the Design Mark in connection with the Accused Product, Defendants are passing off their product as those of PopSockets in a manner that is false, misleading, and misrepresentative of the nature, characteristics, and quality of PopSockets' services.

118. On information and belief, Digital Metro has and will continue to make profits and gains as a result of its infringing activity.

119. Digital Metro's acts have damaged and will continue to damage PopSockets, including damage to its goodwill and reputation, and PopSockets has no adequate remedy at law.

**COUNT TWELVE
COMMON LAW UNFAIR COMPETITION BY TEJANI**

120. PopSockets repeats and incorporates by reference the allegations contained in paragraphs 1 through 119 as if fully set forth herein.

121. On information and belief, as the President of Digital Metro, Tejani is directly responsible for the day-to-day operations of Digital Metro, and Tejani willfully, knowingly, and personally participated in and directed all of the infringing activities undertaken by Digital Metro.

122. On information and belief, Tejani instructed and induced Digital Metro to continue using the mark without permission from PopSockets although Tejani knew or should have known about PopSockets' Design Mark.

123. Tejani's use of the Design Mark constitutes unfair competition under Texas common law.

124. Through Defendants use of the Design Mark in connection with the Accused Product, Defendants are passing off their product as those of PopSockets in a manner that is false, misleading, and misrepresentative of the source, nature, characteristics, and quality of PopSockets' services.

125. On information and belief, Tejani has and will continue to make profits and gains as a result of his infringing activity.

126. Tejani's acts have damaged and will continue to damage PopSockets, including damage to its goodwill and reputation, and PopSockets has no adequate remedy at law.

PRAYER FOR RELIEF

PopSockets requests that the Court enter judgment against Defendants as follows:

- A. The '031 Patent and '022 Patent have been infringed by each Defendant;
- B. Each Defendants' infringement of the '031 Patent and '022 Patent has been willful;
- C. An injunction against further infringement of the '031 Patent and '022 Patent;
- D. PopSockets' copyrights in the Works of Art have been willfully infringed by each Defendant;
- E. An injunction against further infringement of PopSockets' copyrights;
- F. PopSockets' trademark rights in the Design Mark have been willfully infringed by each Defendant;
- G. Any injunction against further infringement of PopSockets' Design Mark or any variant thereof;
- H. An award of damages not less than a reasonable royalty, together with pre-judgment and post-judgment interest to compensate for Defendants' infringement of the '031 Patent and '022 Patent and copyrights as allowed by law;
- I. An award to PopSockets for enhanced damages resulting from the knowing, deliberate, and willful nature of Defendants' unlawful conduct, as provided under 35 U.S.C. § 284;
- J. A determination that this is an exceptional case within the meaning of 35 U.S.C. § 285 and an award to PopSockets of its costs, expenses, and reasonable attorneys' fees incurred in this action;

K. Order the impoundment and destruction of all copies of the infringing work in the possession or control of any of the Defendants or their agents, employees, and affiliated companies;

L. Award PopSockets such actual damages as it has sustained as a result of Defendants' copyright infringement, pursuant to 17 U.S.C. § 504(b);

M. Require Defendants to account for and disgorge to PopSockets all gains, profits, and advantages derived by its copyright infringement, pursuant to 17 U.S.C. § 504(b);

N. Require Defendants pay damages incurred by PopSockets as a result of Defendants' violations of 15 U.S.C. § 1125(a) and Texas law;

O. Award PopSockets trebling damages for all trademark damages assessed herein;

P. Award PopSockets exemplary and punitive trademark damages; and

Q. Such other equitable or legal relief as this Court deems just and proper under the circumstances.

Respectfully submitted,

By: /s/ Adam Sanderson

Adam Sanderson
Texas State Bar No. 2406264
REESE GORDON MARKETOS LLP
750 N. St. Paul St., Ste. 600
Dallas, Texas 75069
T: 214.382.9806
F: 214.501.0731
E: adam.sanderson@rgmfirm.com

*Of Counsel, Motion for Pro Hoc Admission
Forthcoming:*

Benjamin T. Horton
Illinois Bar No. 6286428
Tron Y. Fu
Illinois Bar No. 6309042
Michelle Bolos
Illinois Bar No. 6323655

MARSHALL, GERSTEIN & BORUN LLP
6300 Willis Tower
233 S. Wacker Dr.
Chicago, IL 60606
T: 312.474.6300
F: 312.474.0448
E: bhorton@marshallip.com
E: tfu@marshallip.com
E: mbolos@marshallip.com

Attorneys for Plaintiff PopSockets LLC

EXHIBIT A

(12) **United States Patent**
Barnett et al.

(10) **Patent No.:** **US 8,560,031 B2**
(45) **Date of Patent:** **Oct. 15, 2013**

(54) **EXTENDING SOCKET FOR PORTABLE MEDIA PLAYER**

(76) Inventors: **David B. Barnett**, Boulder, CO (US);
Lawrence E. Carlson, Boulder, CO (US)

(*) Notice: Subject to any disclaimer, the term of this patent is extended or adjusted under 35 U.S.C. 154(b) by 0 days.

(21) Appl. No.: **13/403,729**

(22) Filed: **Feb. 23, 2012**

(65) **Prior Publication Data**

US 2012/0329534 A1 Dec. 27, 2012

Related U.S. Application Data

(60) Provisional application No. 61/453,375, filed on Mar. 16, 2011.

(51) **Int. Cl.**
H04M 1/00 (2006.01)

(52) **U.S. Cl.**
USPC **455/575.8**; 455/575.1; 455/550.1; 455/556.1; 455/556.2

(58) **Field of Classification Search**
USPC 455/575.8, 575.1, 550.1, 556.1, 556.2; 379/426, 446
See application file for complete search history.

(56) **References Cited**

U.S. PATENT DOCUMENTS

4,955,493 A	9/1990	Touzani	
5,568,549 A *	10/1996	Wang	379/446
6,196,850 B1	3/2001	Dietz et al.	
D471,547 S	3/2003	Ruohonen	
6,776,660 B1	8/2004	Kubota et al.	
6,781,522 B2	8/2004	Sleva et al.	

D532,004 S	11/2006	Kettula et al.	
7,324,156 B2	1/2008	Lohr et al.	
D570,593 S	6/2008	Justiss	
7,422,486 B2	9/2008	Hoff et al.	
7,540,788 B2	6/2009	Murphy et al.	
7,581,119 B2	8/2009	Tupman et al.	
7,644,895 B2	1/2010	Tseng	
7,678,271 B2	3/2010	Curtin	
7,782,610 B2	8/2010	Diebel et al.	
7,983,034 B1	7/2011	Mohoney	
D647,085 S	10/2011	Chung et al.	
8,078,224 B2	12/2011	Fadell et al.	
8,080,975 B2	12/2011	Bessa et al.	
2005/0243522 A1	11/2005	Nilsen et al.	
2007/0093786 A1	4/2007	Goldsmith et al.	
2007/0164036 A1 *	7/2007	Brandenburg	220/676
2008/0053770 A1	3/2008	Tynyk	
2008/0090443 A1	4/2008	Ackloo	
2008/0123287 A1	5/2008	Rossell et al.	
2008/0146958 A1	6/2008	Guillory et al.	
2008/0221404 A1	9/2008	Tso	

(Continued)

Primary Examiner — Kathy Wang-Hurst
(74) *Attorney, Agent, or Firm* — Jennifer L. Bales; Micheledt Bales LLP

(57) **ABSTRACT**

Extending sockets, formed of accordions generally with buttons attached at their distal ends, for attaching to portable media players or portable media player cases. Cases having attached sockets serve purposes beyond protection of the player, such as managing a headset, attaching to belts or the like, forming stand legs to prop the player at a desired angle, forming grips for gaming, forming a grip for securely holding and manipulating player with one hand, and forming extended legs for wedging players that are phones between the ear and shoulder. The sockets are structured to allow headset cords to be wound around the accordions when the sockets are extended, to prevent the cords from tangling. Space in an attached case may be provided so that the sockets may be partially or fully retracted with headphone cords wrapped around them to save space.

22 Claims, 9 Drawing Sheets

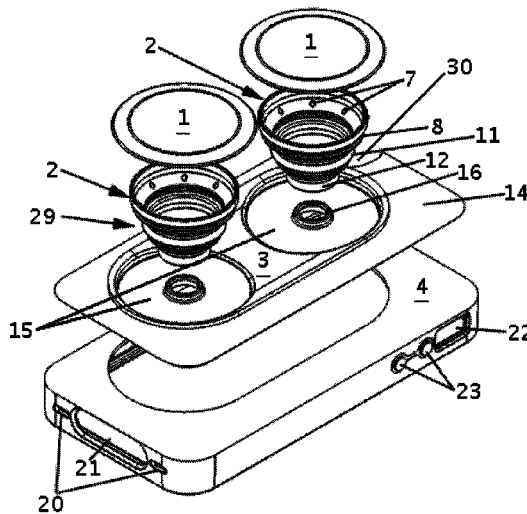

US 8,560,031 B2

Page 2

(56)

References Cited

U.S. PATENT DOCUMENTS

2008/1268916 10/2008 Lin et al.
2008/0273297 A1 11/2008 Kumar
2009/0115367 A1 5/2009 Kidakam
2009/0240297 A1 9/2009 Shavit et al.

2011/0015496 A1 1/2011 Sherman et al.
2011/0036876 A1 2/2011 Fathollahi
2011/0084081 A1* 4/2011 Chung et al. 220/628
2011/0117974 A1 5/2011 Spitalnik
2011/0252839 A1 10/2011 Stevens
2011/0301439 A1 12/2011 Albert et al.

* cited by examiner

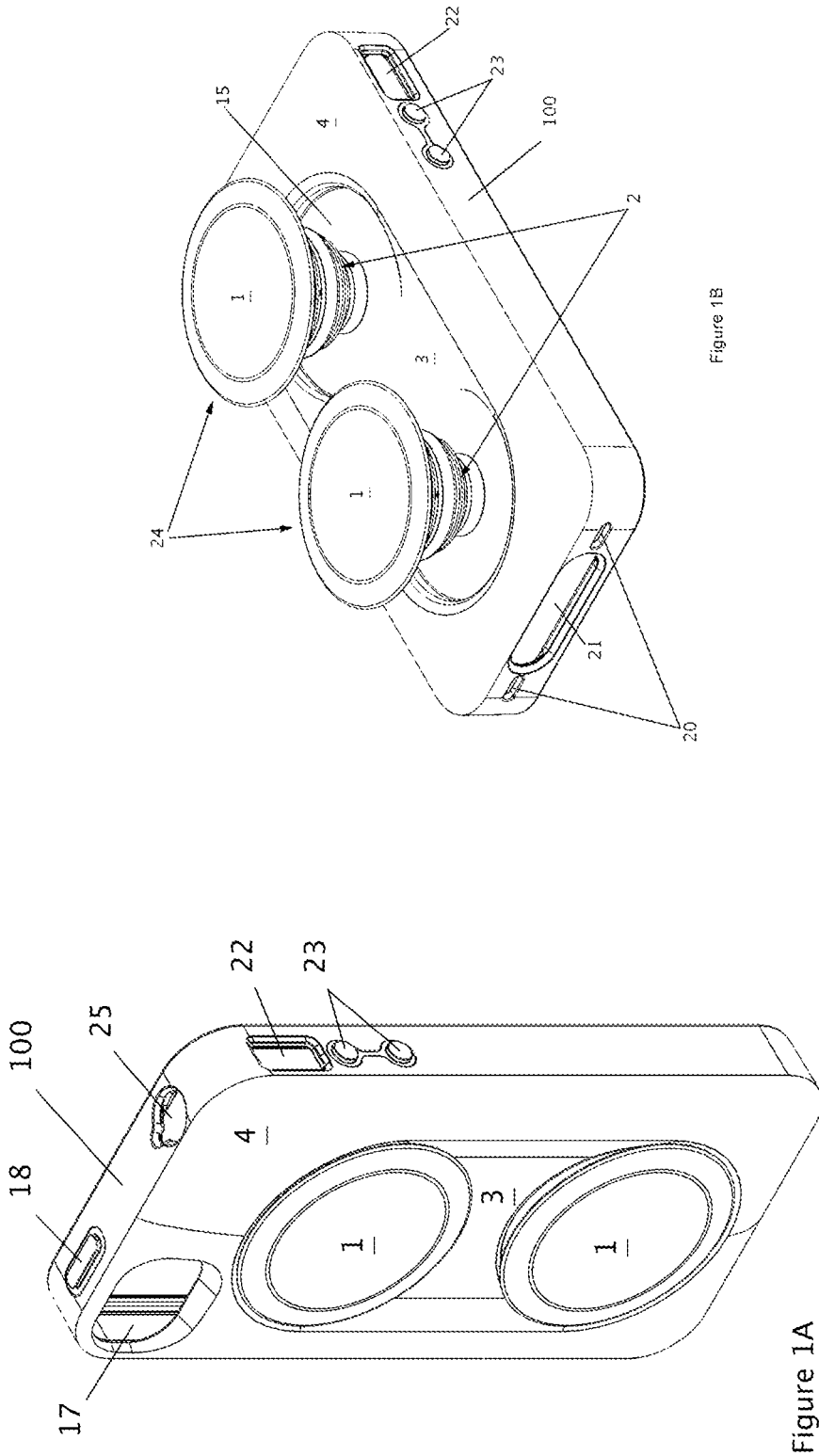

Figure 1B

Figure 1A

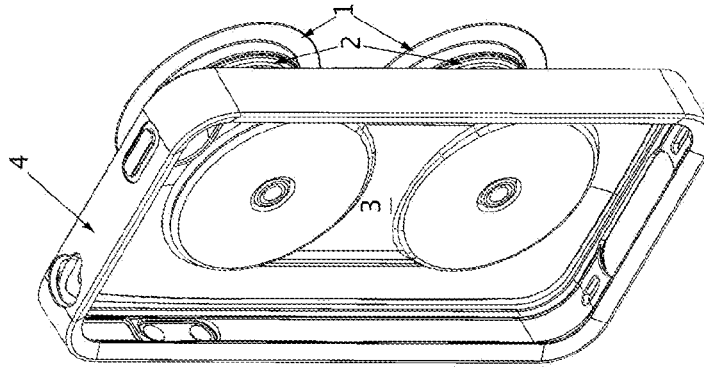

Figure 1E

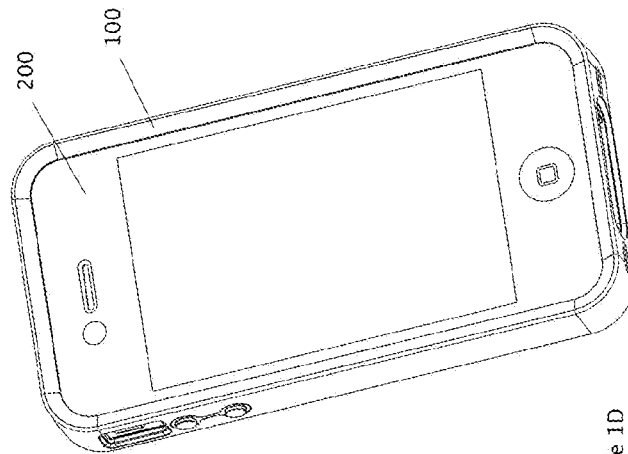

Figure 1D

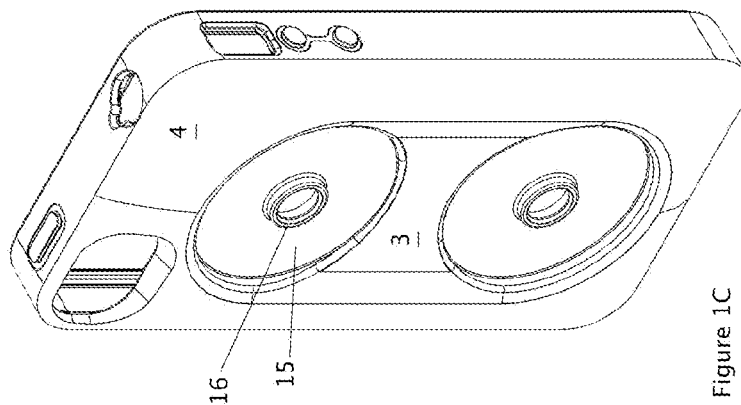

Figure 1C

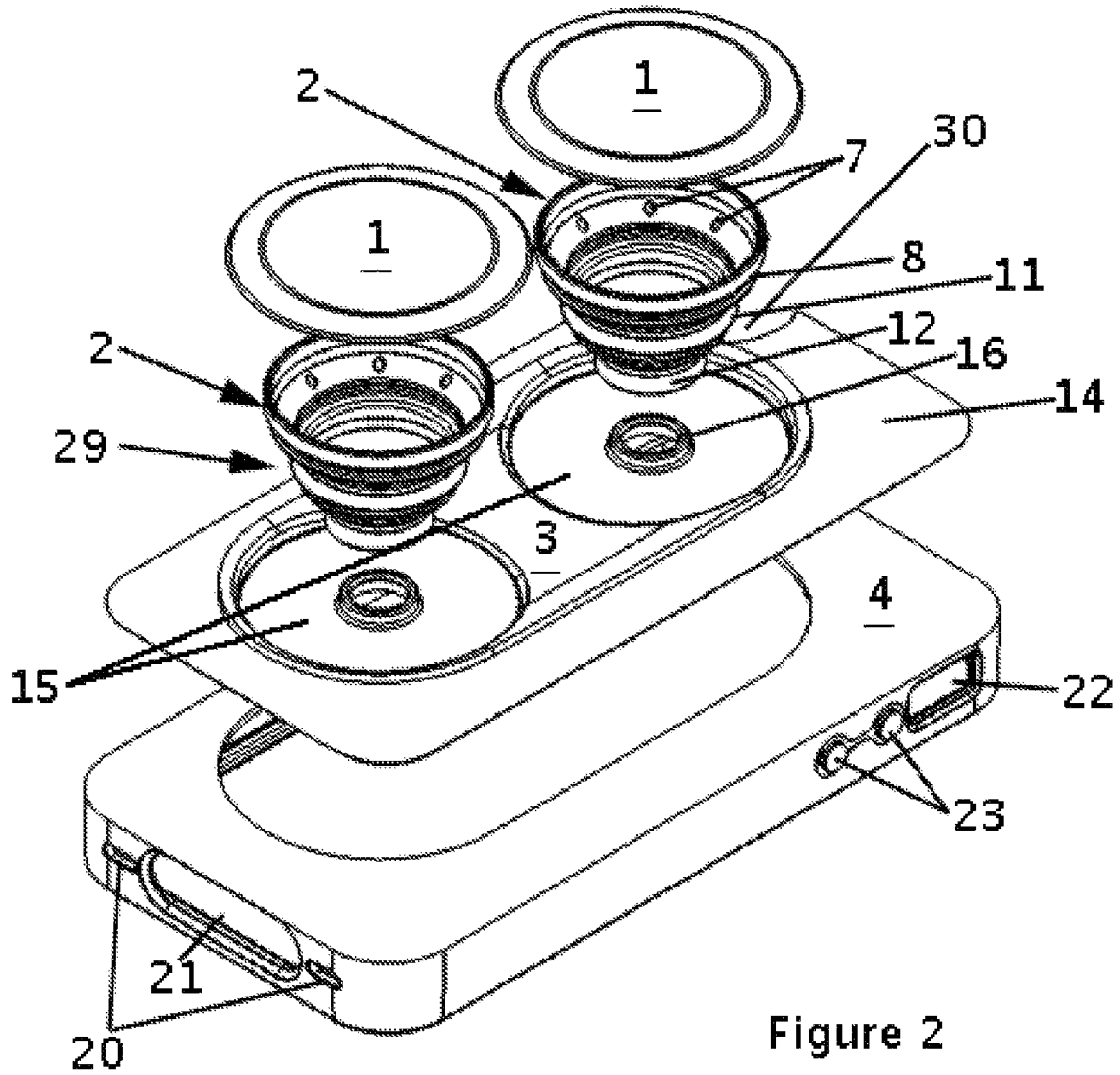

Figure 2

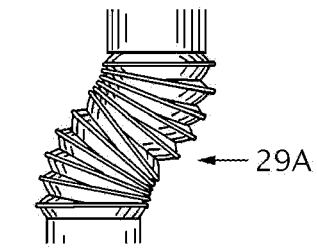
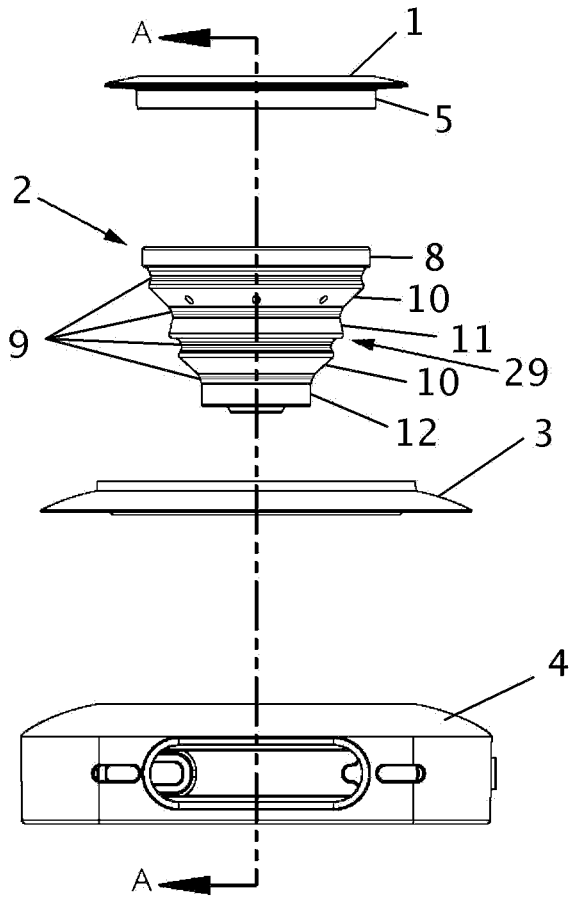

Figure 3B

Figure 3A

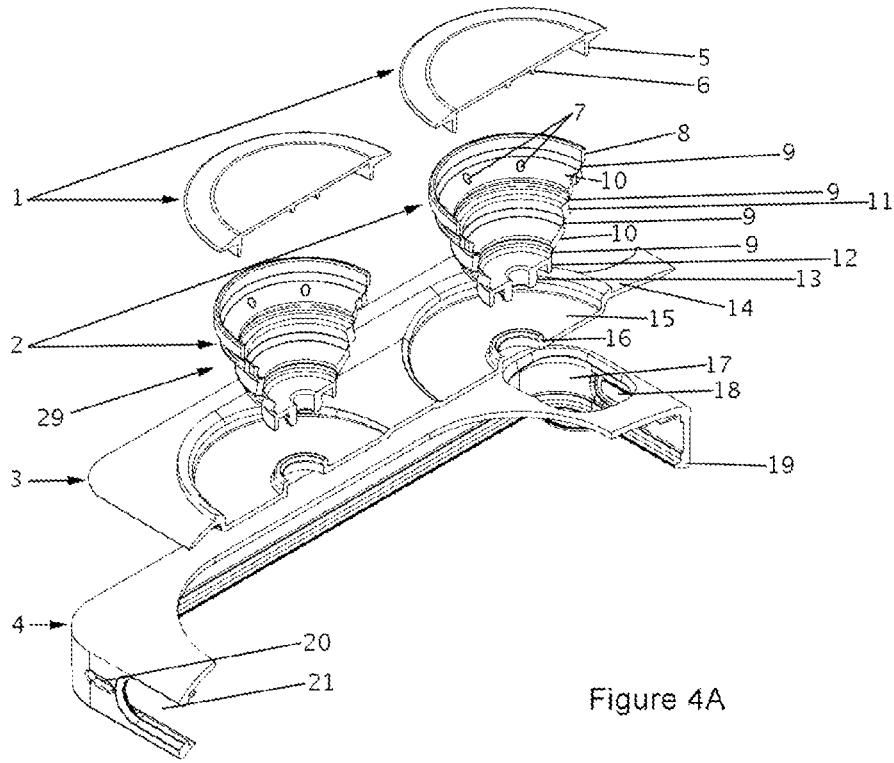

Figure 4A

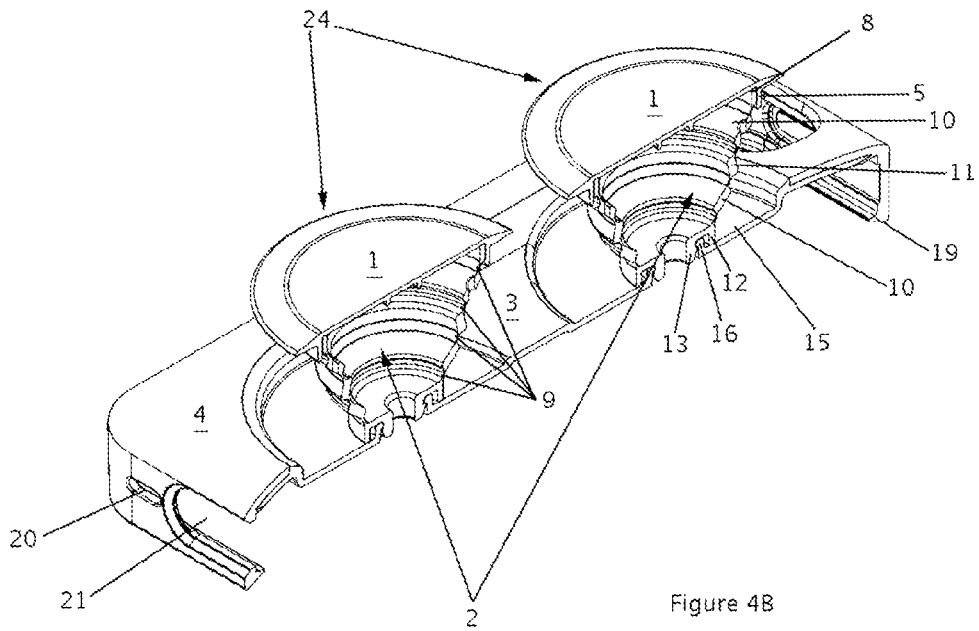

Figure 4B

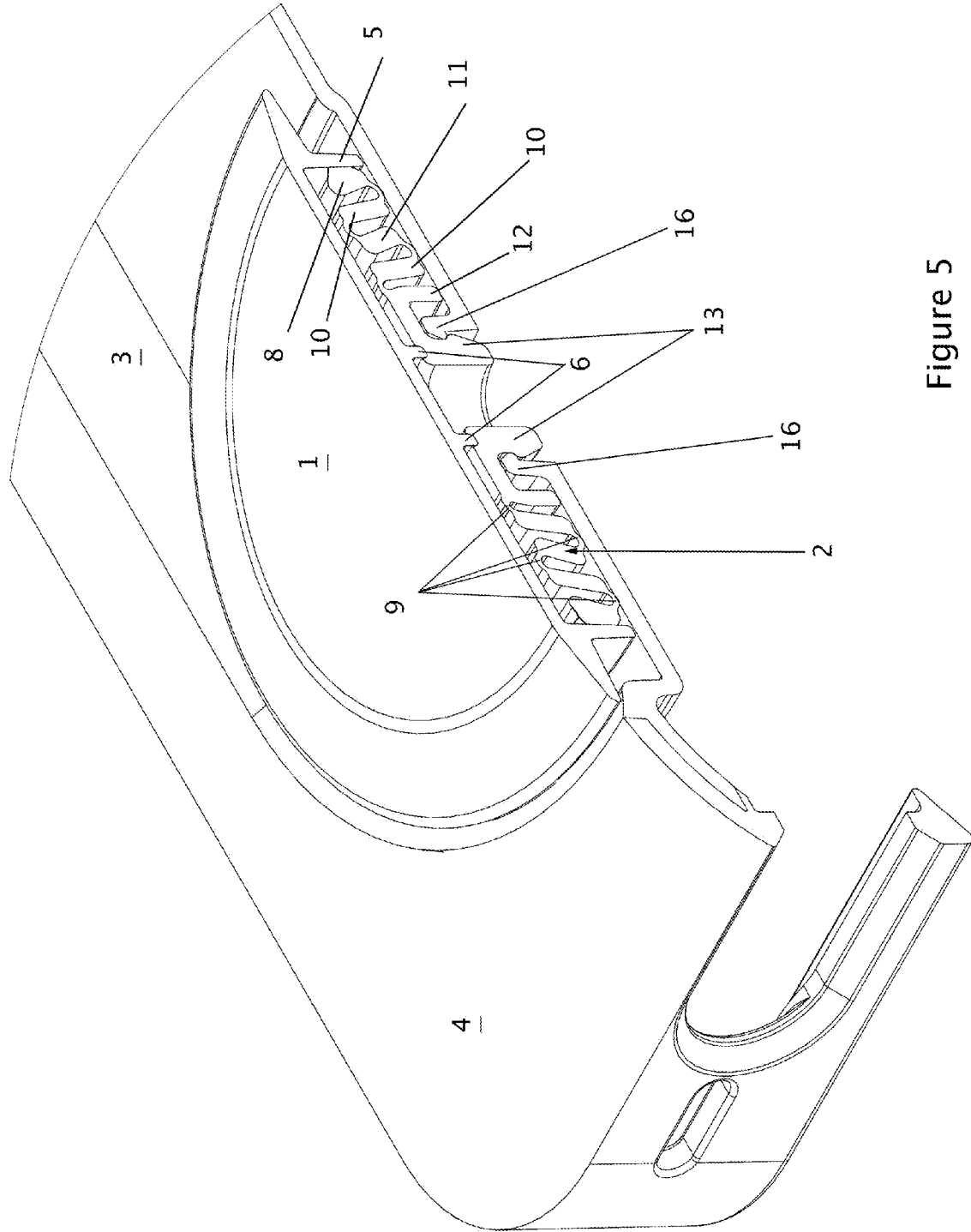

Figure 5

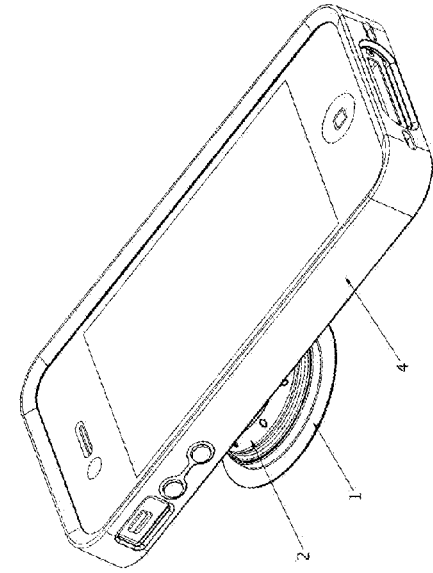

Figure 6

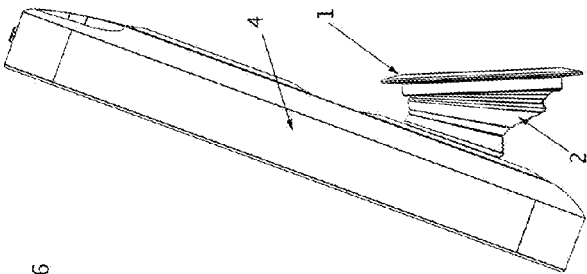

Figure 7

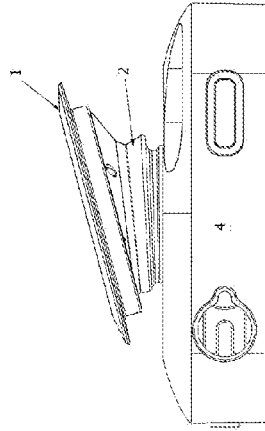

Figure 8

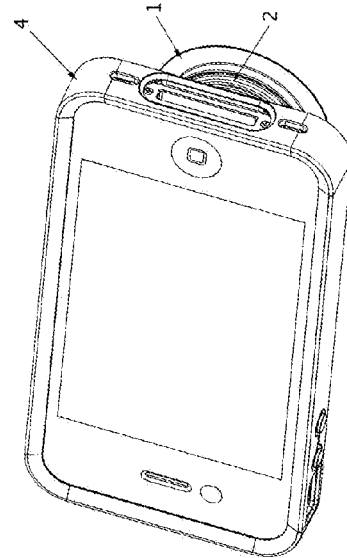

Figure 9

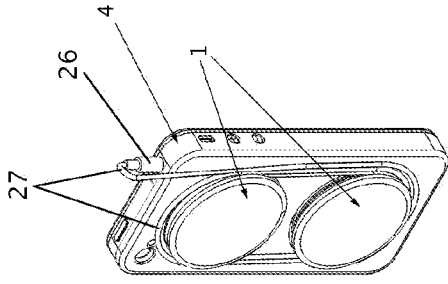

Figure 10B

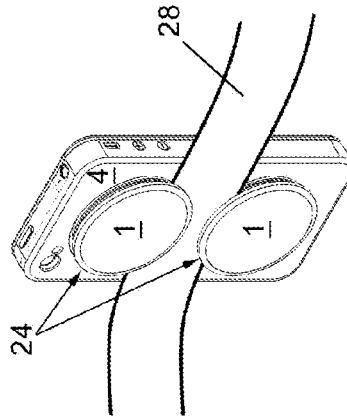

Figure 11B

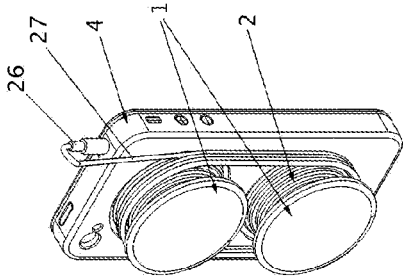

Figure 10A

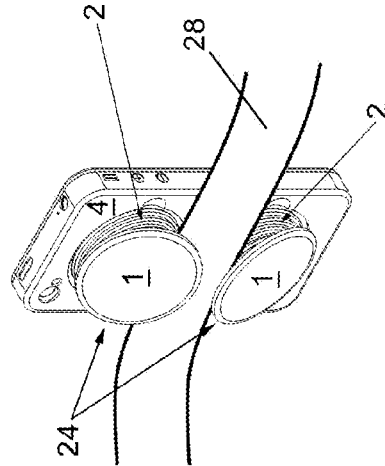

Figure 11A

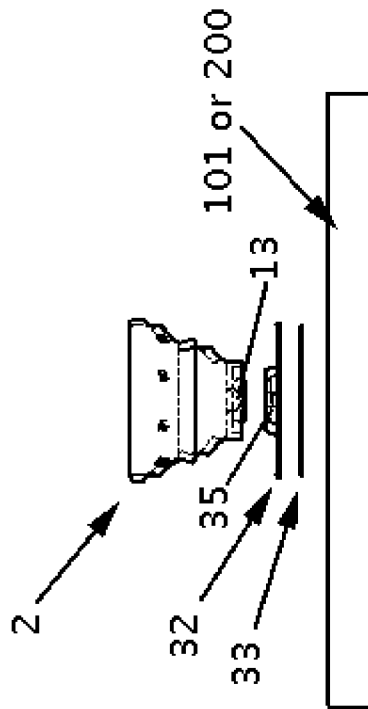

Figure 12B

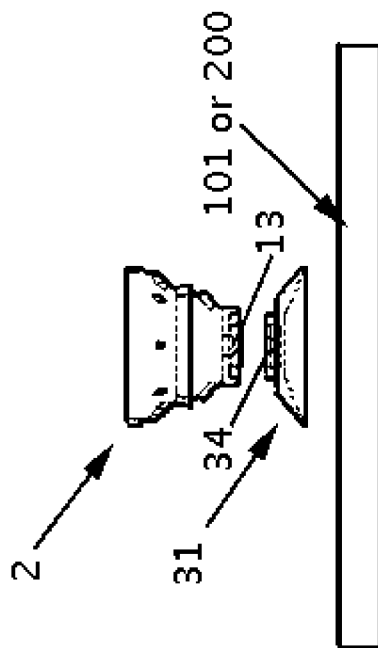

Figure 12A

US 8,560,031 B2

1

EXTENDING SOCKET FOR PORTABLE MEDIA PLAYER

BACKGROUND OF THE INVENTION

1. Field of the Invention

The present invention relates to extending sockets for portable media players. In particular, embodiments of the one or more present inventions relate to portable media cases including one or more socket extensions.

2. Discussion of Related Art

Portable media players such as MP3 players and smart phones are often housed in protective covers or cases in order to protect the media player from scratching or damage from dropping. Such cases increase the effective size of the media player and typically serve no purpose beyond protection.

Some portable media player cases include an extra feature to enable a single further function beyond protection. For instance, some cases have an arm that extends for standing the case on its side; one has an arm that extends for headset management; some have a pocket for storing headsets; some have two humps to function as gaming grips; one has two extendable flaps with finger holes to be used as gaming grips; and some have a clip for mounting the player on a belt. However, there is no case that serves all of these functions, and there is no case that serves the mounting functions without adding significant effective size to the player.

A need remains in the art for portable media player cases and extending sockets that perform a multitude of functions, such as the aforementioned functions, without adding significantly to the effective size of the player.

SUMMARY OF THE INVENTION

One or more embodiments of the one or more present inventions are directed to portable media player cases that include extending sockets for serving other purposes beyond protection of the player itself, such as one or more of storing headphone cords and preventing the cords from tangling, forming stand legs, forming gaming grips, clipping to belts, waistbands and shirt pockets, forming legs for wedging players that are phones between the shoulder and ear, and forming a grip that allows a user to securely hold and manipulate the player with one hand. Such cases include sockets extendable outward from the case. The sockets generally include extending elements, called "accordions," comprising cylindrical or conical membranes with flexural hinges having feet at their distal ends. The sockets are structured to allow headphone cords to be wound around the accordions when the sockets are extended, to prevent the cords from tangling. Cavities in the case are provided so that the sockets may collapse flush with the case and may be partially or fully retracted with headphone cords wrapped around them in order to save space. Buttons may attach at the distal ends of the socket and in at least one embodiment are rigid, and in at least one embodiment extend radially past the distal end of the sockets to secure cords and the like.

In at least one embodiment, the sockets further act as stand legs for propping the player in various tilted or upright positions for viewing, data entry, video conferencing, etc. In their expanded states, the sockets act as comfortable grips for gaming, data entry, and searching the Internet. In at least one embodiment, the sockets act as a belt mount: two sockets can collapse onto a belt between them, thereby securing the belt between the sockets and the back of the case. The sockets in their expanded state facilitate hands-free talking on phone players, allowing user to comfortably wedge the player

2

between the ear and shoulder. A socket in its expanded state facilitates one-hand control of the player by allowing the user to wedge fingers between the socket and the back of the case, while manipulating the front of the player with the thumb of the same hand.

The extending elements may comprise accordions, including flexural hinges interspersed with walls. The accordion structures allow the buttons to extend not just straight outward from the case, but also to curve away from the outward axis at various oblique angles. The buttons may snap onto the ends of the accordions, be glued on, or be feet integrally formed with the accordions. In particular, in at least one embodiment the accordions form cones having rotating "flipper" walls as well as fixed walls that jointly result in the walls folding down next to one another (such that the walls are generally parallel to the axis of the accordion) rather than stacking on top of one another.

A socket maintains full functionality without the buttons, and its feet may further form suction cups for attaching the player temporarily to flat surfaces. A socket may be attached to the case or directly to a portable media player. It may be attached permanently or temporarily, for instance by snap-fit or suction cup, and it may be integrally formed with the case. The buttons' purpose includes, but is not limited to, decoration. Designs can be added to the surface of the buttons. The buttons may also take on different forms to play different roles, such as mounting jacks for players that function as cameras or suction cups to attach to a surface.

In one embodiment, the case comprises an outer body, covering the edges and part of the back of the player, formed of a soft, flexible material such as thermoplastic urethane; an inner body or "socket-board", covering the inner region of the back of the player, formed of a hard plastic, such as polycarbonate, integrally formed with the outer body; two accordions, formed of flexible material, for example a polyester-based thermoplastic polyurethane elastomer such as Skythane® S190A, snap-fit to the socket-board; and two buttons, formed of hard plastic, such as polycarbonate, glued to the accordions. The case forms an opening for the portable media player screen in the front, with two socket extensions in the back.

Other embodiments include variations in (i) part material; (ii) number of socket extensions; (iii) location of socket extensions; (iv) mode of attachment of button to accordion; (v) mode of attachment of accordion to case body or portable media player; (vi) presence or absence of: button, case body, and socket-board; (vii) number of case body parts; and (viii) presence or absence of a component for connecting sockets extensions to the electronic components of the player to enable further functionality such as speakers.

BRIEF DESCRIPTION OF THE DRAWINGS

FIG. 1 comprises FIG. 1A, 1B, 1C, 1D, and 1E. FIG. 1A is an isometric back view of a portable media player case according to at least one embodiment of the one or more present inventions, wherein the sockets retracted, or collapsed.

FIG. 1B is an isometric back view of the portable media player case of FIG. 1A with its sockets opened, or extended.

FIG. 1C is an isometric back view of the portable media player case of FIG. 1A, with its sockets removed.

FIG. 1D is an isometric front view of the portable media player case of FIG. 1A, with a smart phone disposed within the case.

FIG. 1E is an isometric front view of the portable media player case of FIG. 1A, with the smart phone removed.

FIG. 2 is an isometric exploded back view of the portable media player case of FIG. 1.

FIG. 3 comprises FIGS. 3A and 3B. FIG. 3A is an exploded end view of the media case of FIG. 1. FIG. 3B is a side view of an alternative folding section.

FIG. 4 comprises FIGS. 4A and 4B. FIG. 4A is a cutaway, isometric, exploded, side view of the portable media player case of FIG. 1, sectioned along the line A-A indicated in FIG. 3A. FIG. 4B is a cutaway isometric side view of the portable media player case of FIG. 1.

FIG. 5 is a detailed cutaway isometric side view of a portion of the portable media player case of FIG. 1 sectioned along the line A-A indicated in FIG. 3A.

FIG. 6 is a side view of the portable media case of FIG. 1 propped upright by extending the lower of the two sockets at an oblique angle to the case.

FIG. 7 is an isometric side view of the portable media player case of FIG. 1 tilted by extending the upper of the two sockets.

FIG. 8 is an isometric side view of the portable media player case of FIG. 1 disposed sideways and tilted by extending the two sockets.

FIG. 9 is a side view of the portable media player case with both sockets partially extended at an oblique angle, to allow for a shallow horizontal stand by resting case on faces of buttons or a steep horizontal stand by resting case on edges of buttons extended farthest from case.

FIG. 10 comprises FIGS. 10A and 10B. FIG. 10A is a back isometric view of a portable media player case according to an embodiment of the present invention with the sockets extended and a headphone cord wrapped around the accordions.

FIG. 10B is a back isometric view of a portable media player case according to an embodiment of the present invention with the sockets partially retracted and a headphone cord wrapped around the accordions.

FIG. 11 comprises FIGS. 11A and 11B. FIG. 11A is a back isometric view of a portable media player case according to an embodiment of the present invention with the sockets extended in oblique configurations and a belt inserted between the sockets.

FIG. 11B is a back isometric view of a portable media player case according to an embodiment of the present invention with the sockets almost completely retracted and a belt inserted between the sockets.

FIG. 12 comprises FIGS. 12A and 12B. FIG. 12A is an exploded side view of a socket including an accordion and a suction cup, and either a portable media player or a portable media player case according to an embodiment of the present invention wherein the socket attaches to a portable media player or portable media player case by way of a suction cup that is snap-fit to one end of the accordion. FIG. 12B is an exploded side view of a socket, with a suction-cup tape platform, suction-cup tape, and either a portable media player or a portable media player case according to an embodiment of the present invention wherein the socket attaches to a portable media player or portable media player case by way of suction-cup tape whose surface opposite the suction-cup surface is glued to a semi-rigid platform that snap-fits to one end of the accordion.

DETAILED DESCRIPTION OF THE INVENTION

The following table lists elements of the illustrated embodiments of the invention and their associated reference numbers for convenience.

Ref. No.	Element
1.	Button
2.	Accordion
3.	Socket-board
4.	Outer case body
5.	Vertical button wall
6.	Button ring
7.	Accordion vent
8.	Accordion top vertical wall
9.	Accordion flexural hinge
10.	Accordion flipper wall
11.	Accordion middle vertical wall
12.	Accordion bottom vertical wall
13.	Accordion male snap-fit
14.	Socket-board flange
15.	Socket-board socket cavity
16.	Socket-board female snap-fit
17.	Case body camera hole
18.	Case body power button hole
19.	Case body lip
20.	Case body speaker hole
21.	Case body port hole
22.	Case ringer hole
23.	Case volume button
24.	Socket (comprises 1 and 2)
25.	Headphone jack hole
26.	Headphone jack (not part of invention)
27.	Headphone cord (not part of invention)
28.	Belt (not part of invention)
29.	Folding portion of accordion
30.	Socket-board camera and flash hole
31.	Suction-cup
32.	Suction-cup tape platform
33.	Suction-cup tape
34.	Suction-cup female snap-fit
35.	Suction-cup tape platform female snap-fit
100.	Portable media player case constructed to attach a socket
101.	Portable media player case not constructed to attach a socket (not part of invention)
200.	Media player (not part of invention)

FIG. 1 comprises FIGS. 1A, 1B, 1C, 1D, and 1E. FIG. 1A is an isometric back view drawing of a portable media player case 100 according to the present invention with the accordions 2 of its sockets 24 retracted, or collapsed. FIG. 1B is an isometric back view of portable media player case 100 with its accordions 2 opened, or extended.

Case 100 comprises outer case body 4, including socket-board 3, and sockets 24. Each socket 24 generally comprises a collapsible accordion 2 attached to case 100 such that it collapses to nestle within cavity 15, and a button 1 attached to the distal end of accordion 2. Button 1 may comprise a separate attached element or may be integral with accordion 2.

FIG. 1A shows case 100 in a collapsed configuration. In a preferred embodiment, each socket 24 fits within its cavity 15 (shown in FIG. 1B) such that the outer surface of button 1 is essentially flush with the back of the case body, and the circumference of button 1 fills cavity 15 leaving little gap between button 1 and the back of case body 4. The advantage of this embodiment is that the back of case 100 forms a fairly smooth surface that does not catch on other items or collect detritus. Thus, the case is very similar to conventional portable media player cases in this configuration. Case 100 may be unitary or constructed as shown in FIGS. 2-5, described below.

Like conventional cases, case 100 generally includes openings forming ports applicable to the media player, for example speaker holes 20, port hole 21, ringer hole 22, volume buttons 23, and headphone jack hole 25.

FIG. 1B shows case 100 with accordions 2 of sockets 24 extended. The user pulls buttons 1 out from case body 4, and

US 8,560,031 B2

5

accordions 2 unfold and extend outward. Preferably, accordions 2 are stable in their extended position so they stay open until buttons 1 are pressed and sockets 24 close again. The advantages of extendable sockets 24 are described below in detail, and include allowing headphone cord storage and forming adjustable stands for the media player.

FIG. 1C is an isometric back view of portable media player case 100, with its sockets 24 removed. This allows an unobstructed view of the back of case 100. In this embodiment, the back of case 100 is formed of an attached socket-board 3, forming socket cavities 15 having female snap-fit portions 16 for attaching accordions 2. FIG. 1D is an isometric front view of portable media case 100, with a media player 200 (such as an iPhone™ smart phone) disposed within the case. FIG. 1E is an isometric front view of portable media case 100, with media player 200 removed. Case 100 is sized to fit media player 200. For example, in the case where media player 200 comprises an iPhone™, it might be about 118 mm tall by 62 mm wide by 16 mm thick. Buttons 1 might be around 40 mm in diameter 4 mm thick, and accordions 2 might extend outward about 22 mm.

FIGS. 2-5 show examples of the construction and operation of the case with the sockets. FIGS. 2, 3 and 4A show exploded views of case 100, and FIGS. 4B and 5 show cut-away views, sectioned along line A-A indicated in FIG. 3A, illustrating the operation of the sockets 24.

FIG. 2 is an isometric exploded back view of one embodiment of portable media case 100. In this embodiment, the back surface of outer case body 4 comprises a socket-board 3 including a socket-board flange 14 over-molded onto outer case body 4 and forming socket-board cavities 15 which have female snap-fit portions 16. Sockets 24 comprise accordions 2 and buttons 1. Each accordion 2 includes a male snap-fit portion 13 for attachment to socket-board female snap-fit 16 (better shown in FIGS. 4 and 5). In a preferred embodiment, each accordion is structured with accordion vents 7 to allow for air movement during expansion and contraction, and a folding section 29 comprising walls and hinges (better shown in FIGS. 4 and 5). As an alternative, folding section 29 could be configured similarly to the bendable portion of a bendable straw or Slinky® Pop Toob as shown in FIG. 3B. (see for example U.S. Pat. Nos. 2,094,268 and 4,846,510, incorporated herein by reference).

In a preferred embodiment, case body 4 is formed of TPU or TPE. Socket-board 3 is formed of PC or ABS, as are buttons 1. Accordions 2 are formed of Skythane® S190A or low-density polypropylene.

FIG. 3 comprises FIGS. 3A and 3B. FIG. 3A is an exploded end view illustrating the structure of a preferred embodiment of accordion 2 in detail. Each accordion 2 includes a folding section 29 comprising a series of relatively rigid walls 10, 11, 12 interspersed with flexural (or “living”) hinges 9, which flex as accordion 2 is collapsed or expanded. Accordion 2 further comprises top vertical wall 8 (for connection to button 1) and bottom vertical wall 12.

FIG. 3B shows an alternative folding section 29A of accordion 2. In these examples, folding sections 29A comprises flexible membranes including hinges. In the embodiment of FIG. 3A, accordion 2 forms a cone. This allows walls 8, 10, 11, 12 to fold next to one another (as shown in FIG. 5) rather than stacking on top of one another as is the case with the embodiment of FIG. 3B. Both embodiments 29 and 29A are stable in various extended configurations.

FIG. 4A is an isometric exploded side view of the portable media case of FIG. 1, sectioned along the line indicated in FIG. 3A. FIG. 4B is a sectioned isometric side view of the portable media case of FIG. 1, after fabrication. Sockets 24

6

are extended outward. As an example, vertical button wall 5 is glued to accordion top vertical wall 8. Accordion male snap-fit 13 engages with socket-board female snap-fit element 16. Other embodiments might have button 1 formed integrally with, or snap-fitted to, accordion 2, or have accordion 2 permanently affixed to socket-board 3.

FIG. 5 is a detailed sectioned isometric side view of a portion of the portable media player case of FIG. 1, sectioned along the line A-A indicated in FIG. 3A. Socket 24 is in its collapsed position. Note that flexing of hinges 9 allows walls 10 and 11 to fold up in a generally parallel configuration next to one another, rather than stacking on top of one another. Walls 10 are designated as flipper walls, because they are oriented diagonally upward when accordions 2 are extended and diagonally downward when accordions 2 are closed. Walls 8, 11, and 12 remain oriented vertically in both configurations, and do not rotate. Wall 5 is rigid and does not rotate. Note that the terms “upward” and “downward” are used for convenience in describing the drawings, but are specifically intended to include the case in various other orientations.

In one embodiment, accordion 2 is a cone formed of Skythane® S190A. Walls 8, 10, 11, 12 are all about 1 to 2 mm thick and 2 to 5 mm long. Flexural hinges 9 are about 0.2 to 0.4 mm thick and 1 to 2 mm long. Flipper walls are about 20-40 degrees off vertical when accordion 2 is in an expanded state. This allows walls 8, 10, 11, 12 to fold next to one another in a generally parallel configuration as show in FIG. 5, reducing the profile of socket 24 in its collapsed configuration.

Button ring 6 presses into accordion male snap-fit 13, in order to urge it to engage with socket-board female snap-fit 16.

FIG. 6 is a side view of portable media case 100 propped upright (called the video conference mode) by extending the lower of the two sockets 24 at an oblique angle to outer case body 4. FIG. 7 is an isometric side view of case 100 slightly tilted (called the text mode) by extending the upper of the two sockets. FIG. 8 is an isometric side view of the case 100 disposed sideways and tilted (called the theater mode) by extending the two sockets 24, either straight out for a steeper angle, or obliquely for a shallower angle.

FIG. 9 is a side view of the portable media case configured in the theater mode similar to FIG. 8, with sockets 24 extended obliquely. When resting on the faces of the buttons in this configuration, portable media case is in what is called surfing mode, well suited for browsing the Internet.

FIG. 10 comprises FIGS. 10A and 10B, and shows case 100 used to retain a headset cord 27 without tangling. FIG. 10A is a back isometric view of case 100 with the sockets extended. The user has inserted a headset jack 26 into media player 200 via headset jack hole 25, and has wound headphone cord 27 around accordions 2. FIG. 10B is similar to FIG. 10A, except that sockets 24 have been mostly retracted. This retains cord 27, reduces the thickness of case 100, and lowers the chance of catching buttons 1 on other objects. It is helpful for buttons 1 to extend radially past accordions 2 so that buttons 1 form a lip for retaining cord 27 (or a belt 28 as shown in FIG. 11).

FIG. 11 comprises FIGS. 11A and 11B, and shows sockets 24 gripping a belt 28, in order to retain case 100. FIG. 11A is a back isometric view of case 100 with the sockets extended, so that belt 28 can be inserted under buttons 1 and between accordions 2. FIG. 11B is similar to FIG. 11A, except that sockets 24 have been mostly retracted, to grip belt 28 more tightly and reduce the profile of case 100.

7

FIG. 12 comprises FIGS. 12A and 12B, and shows socket 24 attaching either to portable media case 101 or to portable media player 200. FIG. 12A is an exploded side view of a socket 24, a suction cup 31, and either a portable media player 200 or a portable media player case 101 according to an embodiment of the present invention wherein the socket attaches to a portable media player 200 or portable media player case 101 by way of a suction cup that is snap-fitted to one end of the socket 24. FIG. 12B is an exploded side view of a socket 24, a suction-cup tape platform 32, suction-cup tape 33, and either a portable media player 200 or a portable media player case 101 according to an embodiment of the present invention wherein the socket 24 attaches to a portable media player 200 or portable media player case 101 by way of suction-cup tape 33 whose surface opposite the suction-cup surface is glued to a platform 32 that is snap-fitted to one end of the socket 24.

While the exemplary preferred embodiments of the present invention are described herein with particularity, those skilled in the art will appreciate various changes, additions, and applications other than those specifically mentioned, which are within the spirit of this invention. For example, media player 200 might be a tablet or an MP3 player or other device such as an iPod Touch™. Case 4 would then be sized accordingly, and the appropriate portholes provided. In addition, more or fewer sockets may be provided. The sockets and buttons may have different shapes and sizes. They might be resilient rather than rigid, or form suction cups.

What is claimed is:

1. A portable media player case for housing a portable media player, comprising:
 - a case body for housing the portable media player; and
 - an extendable socket attached to the case body, the socket including:
 - an accordion forming a tapered shape capable of extending outward from the case body generally along its axis and retracting back toward the case body by collapsing generally along its axis, and
 - a foot disposed at the distal end of the accordion.
2. The case of claim 1 wherein the accordion comprises rigid walls interspersed with flexural hinges.
3. The case of claim 2 wherein the tapered shape comprises a cone shape constructed and arranged such that the walls fold generally parallel to the axis of the accordion when the accordion is collapsed.
4. The case of claim 3 wherein the accordion is formed of polyester-based thermoplastic polyurethane elastomer, the walls are about 1 to 2 mm thick and 2 to 4 mm long, and the flexural hinges are about 0.2 to 0.4 mm thick and 1 to 2 mm long.
5. The case of claim 3 wherein the case body forms a cavity for housing the socket when the accordion is retracted.
6. The case of claim 1 further comprising a button attached to the foot, the button formed of a rigid material and extending radially past the foot.
7. The case of claim 1 further comprising a suction cup attached to the foot.
8. The case of claim 1 wherein the foot comprises a suction cup.
9. A socket for attaching to a portable media player or to a portable media player case, comprising:
 - a securing element for attaching the socket to the back of the portable media player or portable media player case; and
 - an accordion forming a tapered shape connected to the securing element, the accordion capable of extending

8

- outward generally along its from the portable media player and retracting back toward the portable media player by collapsing generally along its axis; and
 - a foot disposed at the distal end of the accordion.
10. The socket of claim 9 wherein the accordion comprises rigid walls interspersed with flexural hinges.
 11. The socket of claim 10 wherein the tapered shape comprises a cone shape constructed and arranged such that the walls fold generally parallel to the axis of the accordion when the accordion is collapsed.
 12. The socket of claim 11 wherein the accordion is formed of polyester-based thermoplastic polyurethane elastomer, the walls are about 1 to 2 mm thick and 2 to 4 mm long, and the flexural hinges are about 0.2 to 0.4 mm thick and 1 to 2 mm long.
 13. The socket of claim 12 further comprising a button attached to the foot, the button formed of a rigid material and extending radially past the foot.
 14. The socket of claim 9 wherein the securing element comprises a suction cup.
 15. The socket of claim 9 wherein the securing element comprises suction-cup tape.
 16. A method comprising the steps of:
 - attaching a socket including an accordion forming a tapered shape and having walls interspaced with flexural hinges to a portable media player;
 - selectively extending the socket by unfolding the accordion generally along its axis; and
 - selectively retracting the socket by folding the accordion generally along its axis such that the walls fold next to each other.
 17. The method of claim 16 wherein the retracting step folds the walls into an orientation such that the walls are generally parallel to the axis of the accordion.
 18. The method of claim 16, wherein the step of attaching the socket comprises the step of enclosing the player in a case already having the socket attached to the case.
 19. The method of claim 16 wherein the step of attaching the socket attaches two sockets to the player.
 20. The method of claim 19 wherein the step of extending the socket extends both of the sockets and the step of retracting the socket retracts both of the sockets and further including the step of winding a cord around the accordions after extending the sockets and before retracting the sockets.
 21. The method of claim 19 wherein the step of extending the socket extends both of the sockets and further includes the step of bending the sockets in a curve away from the original axes of the accordions.
 22. An extending socket for attaching to a portable media player, the socket forming a tapered shape and further comprising:
 - means for attaching the socket including an accordion forming a tapered shape to the back of the portable media player;
 - means for extending the socket outward generally along its axis from the portable media player and retracting the socket back toward the portable media player by collapsing the socket generally along its axis; and
 - a foot disposed at the distal end of the extending and retracting means.

UNITED STATES PATENT AND TRADEMARK OFFICE

CERTIFICATE OF CORRECTION

PATENT NO. : 8,560,031 B2
APPLICATION NO. : 13/403729
DATED : October 15, 2013
INVENTOR(S) : David B. Barnett et al.

Page 1 of 1

It is certified that error appears in the above-identified patent and that said Letters Patent is hereby corrected as shown below:

In the Claims

At Column 7, Line 37, "its and" should be -- its axis and --.

At Column 8, Line 1, "its from" should be -- its axis from --.

At Column 8, Line 44, "retracing" should be -- retracting --.

Signed and Sealed this
Seventh Day of March, 2017

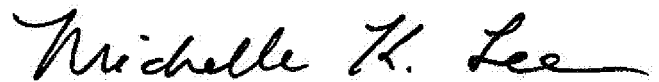

Michelle K. Lee
Director of the United States Patent and Trademark Office

EXHIBIT B

(12) **United States Design Patent** (10) **Patent No.:** **US D777,022 S**
Barnett (45) **Date of Patent:** **** Jan. 24, 2017**

(54) **DEVICE CLIP**
 (71) Applicant: **David B. Barnett**, Boulder, CO (US)
 (72) Inventor: **David B. Barnett**, Boulder, CO (US)
 (73) Assignee: **POPSOCKETS LLC**, Boulder, CO (US)
 (**) Term: **14 Years**
 (21) Appl. No.: **29/520,273**

(22) Filed: **Mar. 12, 2015**
 (51) **LOC (10) Cl.** **08-08**
 (52) **U.S. Cl.**
 USPC **D8/394**
 (58) **Field of Classification Search**
 USPC D32/394–396; D14/400
 CPC .. F16M 13/02; F16M 13/005; F16M 2200/00;
 H01Q 1/24; H01Q 1/244; H05K
 7/12; A63F 13/06
 See application file for complete search history.

(56) **References Cited**

U.S. PATENT DOCUMENTS

2,026,454 A * 12/1935 Benzing F16B 21/186
 301/5.21
 D209,167 S * 11/1967 Huffman D8/396
 4,020,533 A * 5/1977 Darling F01N 13/1805
 24/135 L
 4,084,068 A * 4/1978 Lepik H05K 7/12
 174/138 R
 4,319,758 A * 3/1982 Nicholson F16J 15/3204
 277/345
 4,403,378 A * 9/1983 Engman F01N 13/1805
 24/277
 D305,098 S * 12/1989 Crowle D3/216
 5,197,841 A * 3/1993 Tanaka F16B 21/186
 411/353
 6,544,124 B2 * 4/2003 Ireland A63F 13/06
 273/148 B
 D508,841 S * 8/2005 Jordan, Jr. D8/395
 D514,431 S * 2/2006 Tanaka D8/354
 D592,509 S * 5/2009 Lecoutre D9/434

D597,828 S * 8/2009 Tanaka D8/354
 D601,412 S * 10/2009 Brown D8/395
 D615,131 S * 5/2010 Biheller D14/400
 D639,653 S * 6/2011 Kanda D9/434
 D641,797 S * 7/2011 Chen D14/400
 (Continued)

FOREIGN PATENT DOCUMENTS

WO D046597 * 4/1999

OTHER PUBLICATIONS

Amazon.com: Anti Snoring Nose Clips Snore Stopper Sleep Device, website copyright 2016, https://www.amazon.com/Snoring-Clips-Stopper-Device-STCorps7/dp/B01D6UI93A/ref=sr_1_48?ie=UTF8&qid=1473552041&sr=8-48&keywords=electronic+device+clip, [site visited Sep. 10, 2016 8:02:58 PM].*
 Amazon.com: Jwin Jhe45Sil Ultra Lightweight Ear-Clips For Digital Devices, review date Oct. 15, 2008, https://www.amazon.com/Sil-Lightweight-Ear-Clips-Discontinued-Manufacturer/dp/B000FCP33M/ref=sr_1_122?ie=UTF8&qid=1473552260&sr=8-122&keywords=electronic+device+clip, [site visited Sep. 10, 2016 8:06:01 PM].*

(Continued)

Primary Examiner — John Windmuller
Assistant Examiner — John R Yeh

(57) **CLAIM**

The ornamental design for a device clip, as shown.

DESCRIPTION

FIG. 1 is a front isometric view of a device clip showing my new design;
 FIG. 2 is a front elevational view thereof;
 FIG. 3 is a rear elevational view thereof;
 FIG. 4 is a top plan view thereof;
 FIG. 5 is a bottom plan view thereof;
 FIG. 6 is a left side elevational view thereof; and,
 FIG. 7 is a right side elevational view thereof.

1 Claim, 3 Drawing Sheets

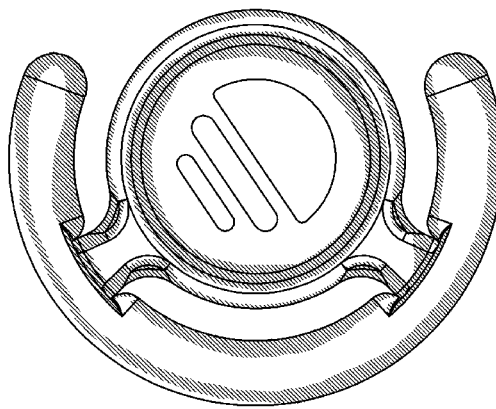
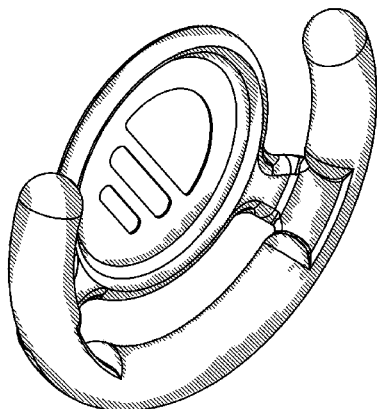

US D777,022 S

(56)

References Cited

U.S. PATENT DOCUMENTS

D658,719	S *	5/2012	Ikeda	D14/400
D661,715	S *	6/2012	Hickman	D15/143
D714,133	S *	9/2014	Kempshall	D8/395
9,151,323	B2 *	10/2015	Hickman	F16C 43/02
2003/0045352	A1 *	3/2003	Ireland	A63F 13/06 463/37
2005/0255918	A1 *	11/2005	Riggs	A47C 3/16 463/37
2006/0140395	A1 *	6/2006	Kim	A45F 5/02 379/428.01
2007/0287537	A1 *	12/2007	Yu	A63F 13/06 463/30
2014/0051518	A1 *	2/2014	Russo	G01C 17/30 463/37

OTHER PUBLICATIONS

Steering Wheel On A White Stock Vector Illustration, Shutterstock website 2016, <http://www.shutterstock.com/pic-91104542/stock-vector-steering-wheel-on-a-white.html?src=eSSaPXYou1PQI5K4lv6DQ-1-76>, [site visited Sep. 10, 2016].*

Racing Style 310mm D Shape PU Alloy Black Sport Racing Steering Wheel | eBay, copyright 2016, <http://www.ebay.com/itm/Racing-Style-310mm-D-Shape-PU-Alloy-Black-Sport-Racing-Steering-Wheel/> 322032561606?hash=item4afaa2edc6:g:dUMAAOSwr7ZW3oX-&vxp=mr, site visited [Sep. 10, 2016 8:38:38 PM].*

* cited by examiner

FIG. 1

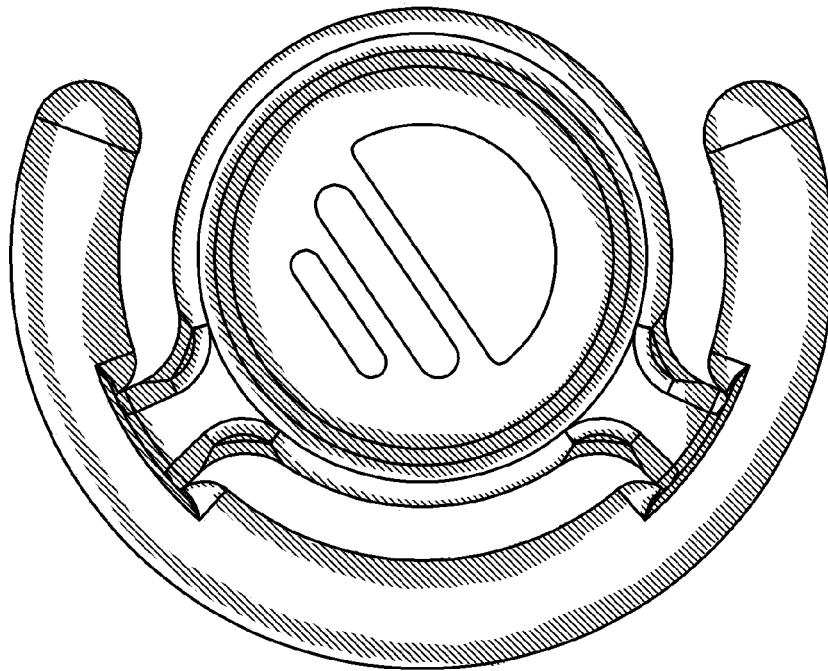
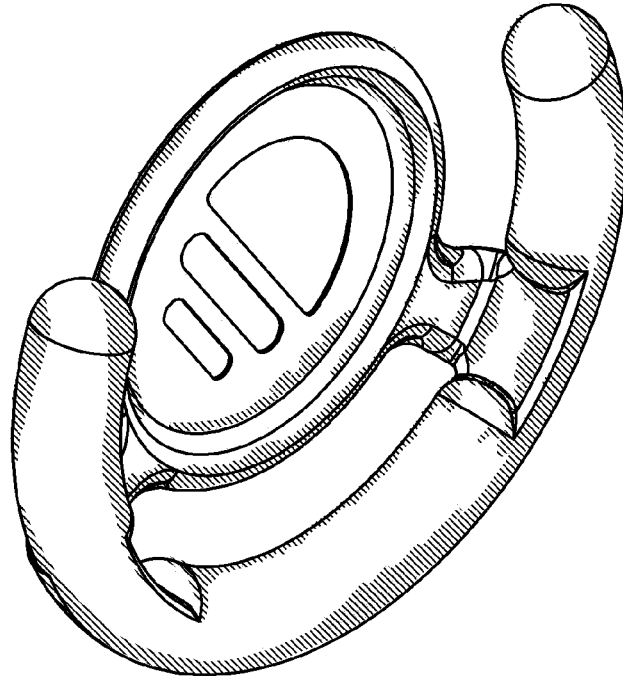

FIG. 2

FIG. 3

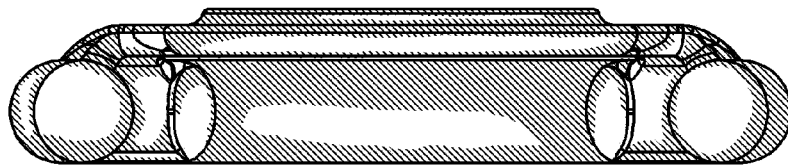
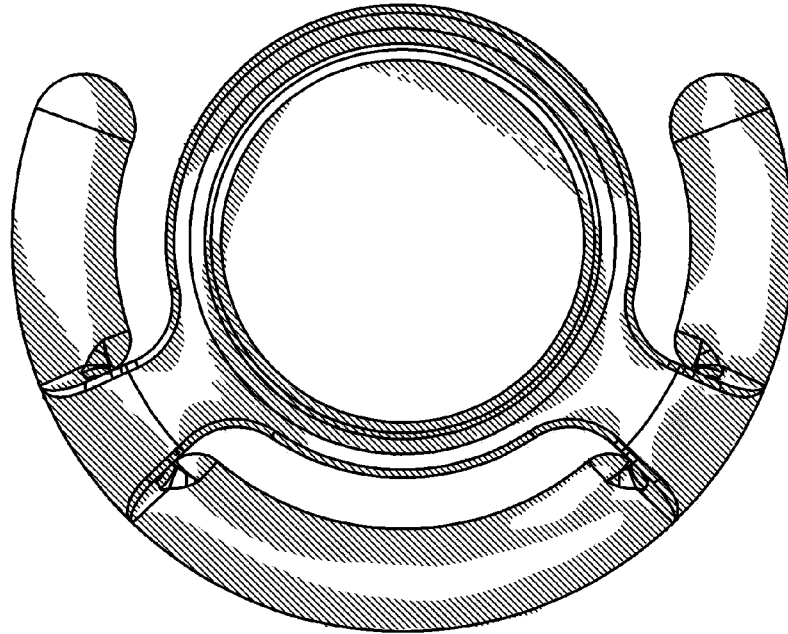

FIG. 4

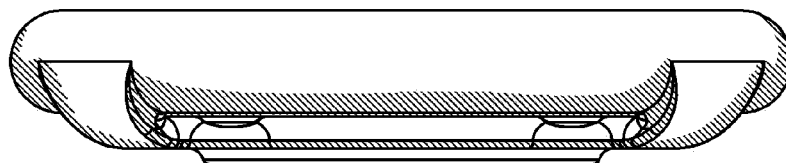

FIG. 5

FIG. 6

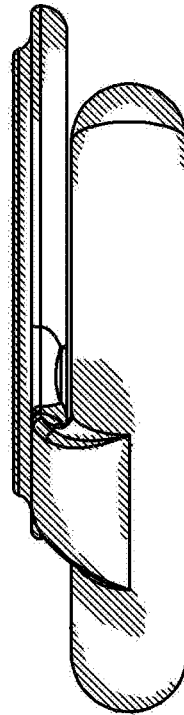

FIG. 7

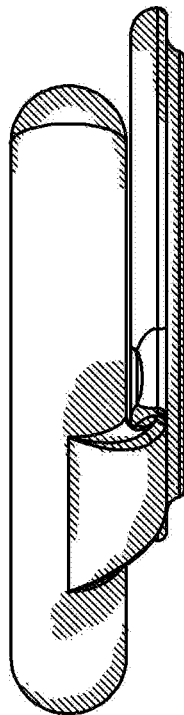

EXHIBIT C





This Certificate issued under the seal of the Copyright Office in accordance with title 17, *United States Code*, attests that registration has been made for the work identified below. The information on this certificate has been made a part of the Copyright Office records.

Karen Leigh Clayett

Acting United States Register of Copyrights and Director

Registration Number

VA 2-058-815

Effective Date of Registration:

July 20, 2017

Title

Title of Work: POP! Graphic

Completion/Publication

Year of Completion: 2014
Date of 1st Publication: February 28, 2015
Nation of 1st Publication: United States

Author

- Author:** Chris Hotz
Author Created: 2-D artwork
Work made for hire: No
Citizen of: United States

Copyright Claimant

Copyright Claimant: PopSockets LLC
3033 Sterling Circle, Boulder, CO, 80301, United States
Transfer statement: By written agreement

Rights and Permissions

Organization Name: Marshall Gerstein & Borun LLP
Name: Benjamin T. Horton
Email: bhorton@marshallip.com
Telephone: (312)474-6300
Address: 233 S. Wacker Drive
Suite 6300
Chicago, IL 60606 United States

Certification

Name: Michelle Bolos
Date: July 20, 2017

Applicant's Tracking Number: 32772/10013

Correspondence: Yes



0000VA00020588150202

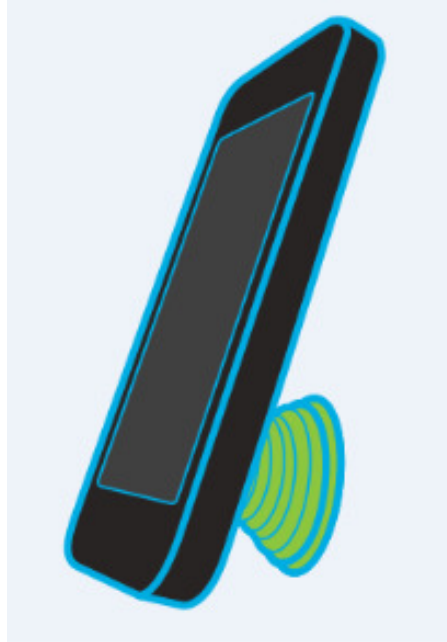



This Certificate issued under the seal of the Copyright Office in accordance with title 17, *United States Code*, attests that registration has been made for the work identified below. The information on this certificate has been made a part of the Copyright Office records.

Karen Leigh Clayette

Acting United States Register of Copyrights and Director

Registration Number

VA 2-058-466

Effective Date of Registration:

July 20, 2017

Title

Title of Work: Media Stand (Portrait)

Completion/Publication

Year of Completion: 2014
Date of 1st Publication: February 28, 2015
Nation of 1st Publication: United States

Author

- Author:** Chris Hotz
Author Created: 2-D artwork
Work made for hire: No
Citizen of: United States

Copyright Claimant

Copyright Claimant: PopSockets LLC
3033 Sterling Circle, Boulder, CO, 80301, United States
Transfer statement: By written agreement

Rights and Permissions

Organization Name: Marshall Gerstein & Borun LLP
Name: Benjamin T. Horton
Email: bhorton@marshallip.com
Telephone: (312)474-6300
Address: 233 S. Wacker Drive
Suite 6300
Chicago, IL 60606 United States

Certification

Name: Michelle Bolos
Date: July 20, 2017

Applicant's Tracking Number: 32772/10013

Correspondence: Yes



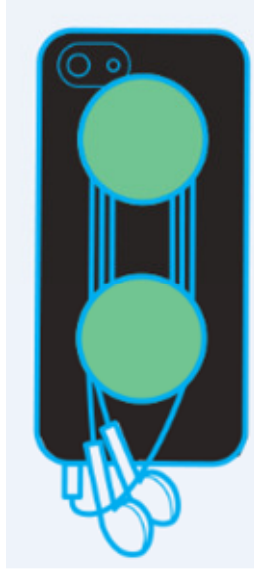



This Certificate issued under the seal of the Copyright Office in accordance with title 17, *United States Code*, attests that registration has been made for the work identified below. The information on this certificate has been made a part of the Copyright Office records.

Acting United States Register of Copyrights and Director

Registration Number

VA 2-058-463

Effective Date of Registration:

July 20, 2017

Title

Title of Work: Cord Wrap

Completion/Publication

Year of Completion: 2014
Date of 1st Publication: February 28, 2015
Nation of 1st Publication: United States

Author

- Author:** Chris Hotz
Author Created: 2-D artwork
Work made for hire: No
Citizen of: United States

Copyright Claimant

Copyright Claimant: PopSockets LLC
3033 Sterling Circle, Boulder, CO, 80301, United States
Transfer statement: By written agreement

Rights and Permissions

Organization Name: Marshall Gerstein & Borun LLP
Name: Benjamin T. Horton
Email: bhorton@marshallip.com
Telephone: (312)474-6300
Address: 233 S. Wacker Drive
Suite 6300
Chicago, IL 60606 United States

Certification

Name: Michelle Bolos
Date: July 20, 2017

Applicant's Tracking Number: 32772/10013

Correspondence: Yes



0000VA00020584630202