

UNITED STATES DISTRICT COURT

Northern District of Indiana

Hammond Division

THOR INDUSTRIES, INC.,)	
Plaintiff,)	
)	
v.)	CASE NO.: 2:17-cv-420
)	
THE RV FACTORY, LLC,)	
Defendant.)	
)	JURY TRIAL DEMAND
)	

COMPLAINT FOR PATENT INFRINGEMENT

Plaintiff, Thor Industries, Inc. (“Thor”), for its Complaint against Defendant, The RV Factory, LLC (“RV Factory”), alleges and states:

The Parties:

1. Thor is a corporation organized under the laws of the State of Delaware, having a principal place of business at 601 East Beardsley Avenue, Elkhart, Indiana 46514.

2. RV Factory is a corporation organized under the laws of the State of Indiana, having a principal place of business at 2503 Marina Drive, Elkhart, Indiana 46514.

Jurisdiction and Venue:

3. This is an action for patent infringement under 35 U.S.C. §§271, *et seq.* This Court has subject matter jurisdiction under 28 U.S.C. §§1331 and 1338.

4. This Court has personal jurisdiction over RV Factory. RV Factory resides in this judicial district and has maintained a regular and established place of business in this judicial district. RV Factory has advertised, made, used, and sold the products which are accused of patent infringement within this judicial district. Thus, venue is proper in this judicial district under 28 U.S.C. §§1391(b)(2) and 1400(b).

The Patents:

5. Thor, through its wholly owned subsidiaries, owns all right, title, and interest in and to United States Patent Nos. 7,575,251 and 7,938,427. These patents were duly and legally issued on August 18, 2009 and May 10, 2011, respectively. Copies of these patents are attached hereto as Exhibits 1 and 2. These patents are referred to herein as the '251 and '427 patents, respectively.

6. In general, the patents are directed to travel trailers, especially fifth-wheel type travel trailers. Prior travel trailers were made with chassis that had a square front end. A top view of the front end of such prior chassis is shown in Figure 9A of the '251 patent and copied below:

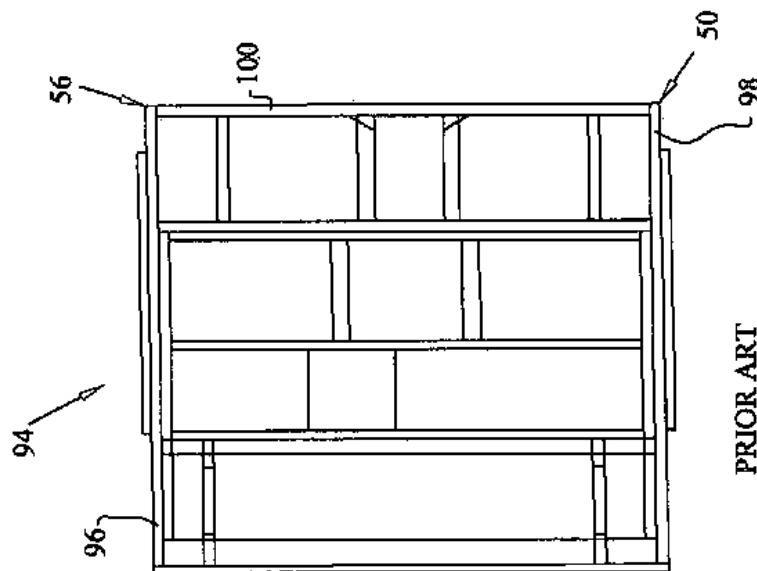

However, the patented travel trailers are made with chassis which have non-square front ends, such as the angled corner front ends of the '251 patent and the curved front end of the '427 patent.

7. In particular, the '251 patent covers travel trailers having a chassis front end such as this, when looking at the forward end of the chassis from the top downward, in Figure 9B of the '251 patent:

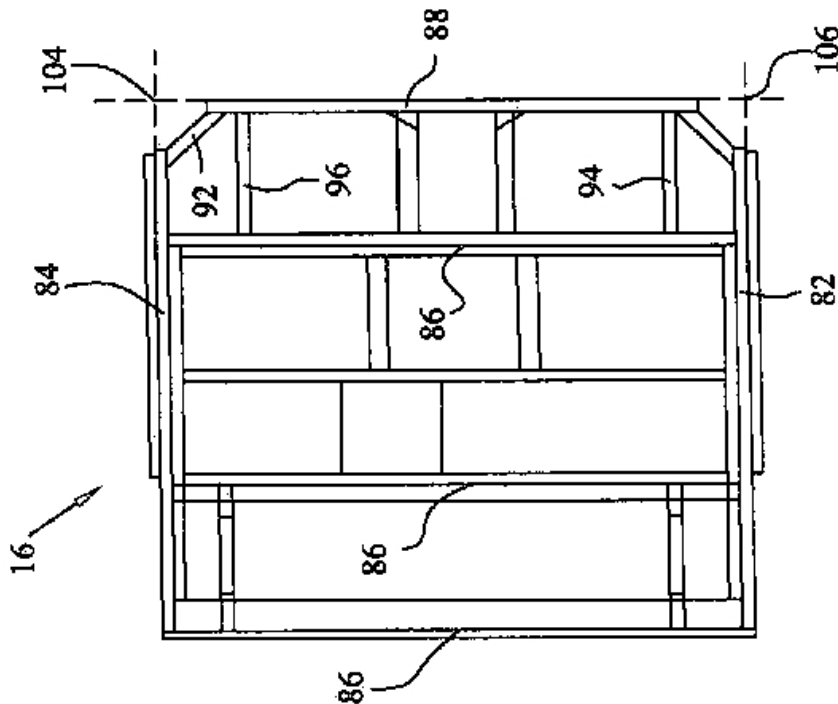

By comparison with the prior types of chassis, the front corners (denoted by numbers 104 and 106), have been formed with angled beams (denoted by numbers 90 and 92) connecting the front beam of the chassis (denoted by number 88) with the respective side beams of the chassis (denoted by numbers 82 and 84). A perspective view of the front of the chassis taken from Figure 10 of the '251 patent illustrates this arrangement as:

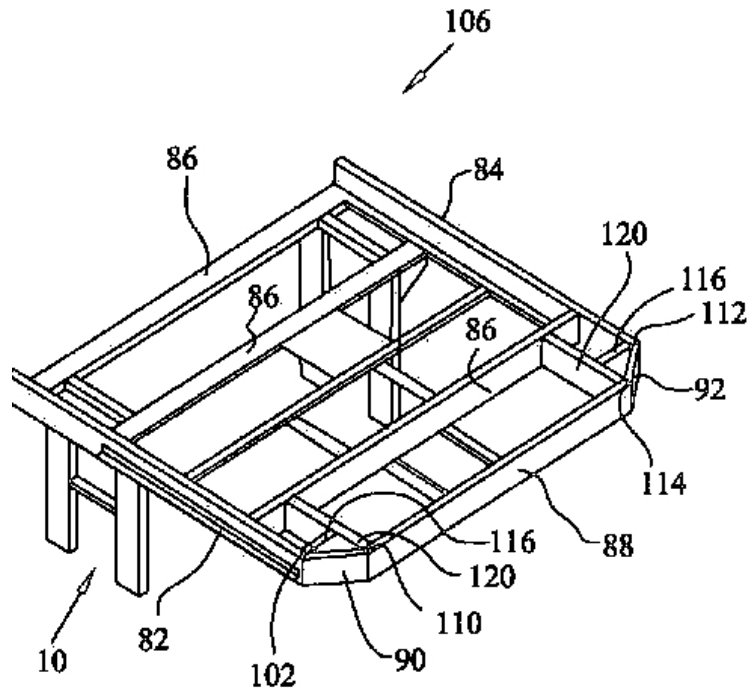
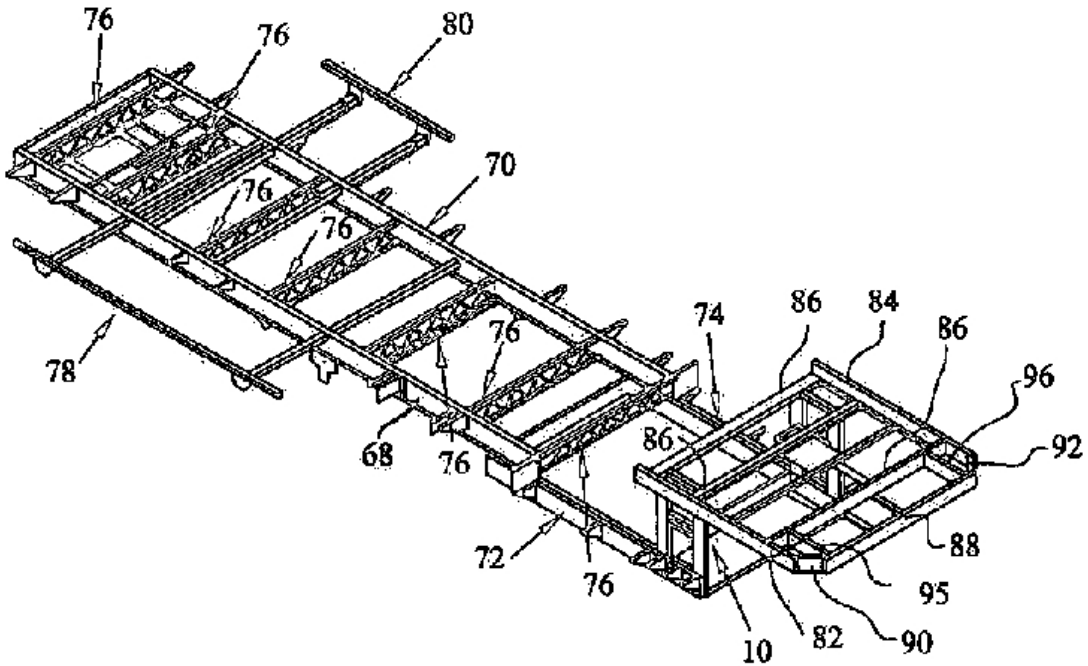
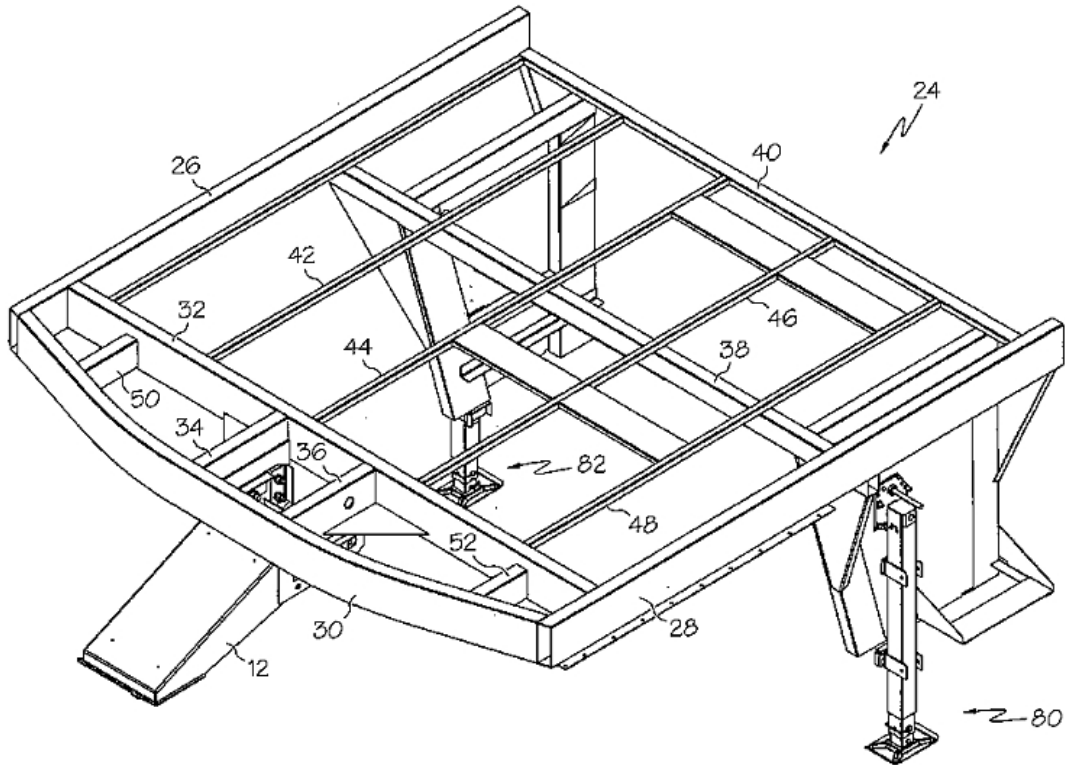

Figure 6 of the '251 patent shows this front end in the context of the entire travel trailer chassis as:



8. Also in particular, the '427 patent covers travel trailers having a chassis front end such as this, when looking at the forward end of the chassis from a perspective view, in Figure 2 of the '427 patent:



By comparison with prior types of chassis, the front end is formed with a curved or bent beam (denoted by number 30) connecting the side beams (denoted by the numbers 26 and 28).

9. Using these non-square front ends on chassis provides travel trailers with certain functional advantages over prior travel trailers. At least some of these advantages are described in the '251 and '427 patents.

10. Claim 1 of the '251 patent defines a fifth-wheel trailer having the following elements:

A. A chassis including:

- B. A forward edge beam
- C. having a first end;
- D. An outer side frame member substantially perpendicular to the forward edge beam,
- E. having a forward end;
- F. A first cross beam substantially perpendicular to the side frame member and connected to the forward end of the side beam member at a location rearward of the forward edge beam;
- G. A second cross beam substantially parallel to the outer side frame member and connected to the first cross beam and the first end of the forward edge beam;
- H. A brace
- I. having a first end connected to the first end of the forward edge beam, and
- J. a second end connected to the forward end of the outer side frame member.

11. Claim 10 of the '427 patent defines a trailer having the following elements:

- K. A trailer body
- L. having a front portion,
- M. that front portion having a generally convex forward surface;
- N. A trailer chassis supporting the trailer body,
- O. including a forward portion supporting the front portion of the trailer body,
- P. that forward portion having a pair of side beams extending along the sides of the trailer body,
- Q. a curved forward edge beam joined to
- R. the forward ends of the pair of side beams, and

S. the curved forward edge beam generally matching the curve of the front portion of the trailer body to provide support for the trailer body.

The Accused Products of RV Factory:

12. RV factory makes, uses, and sells a style of travel trailer which it refers to as “Luxe Luxury Fifth Wheel.” RV factory advertises these products for sale on the internet at <https://luxefifthwheel.com/products/luxe-luxury-fifth-wheel>. That advertisement shows the following chassis being used for such fifth wheel trailers:

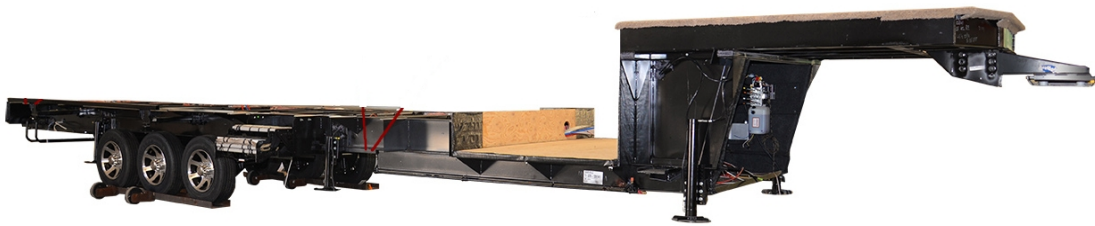

The forward end of that chassis is enlarged below with the corresponding equivalent elements of Claim 1 of the ‘251 patent designated therein, as per ¶10 above:

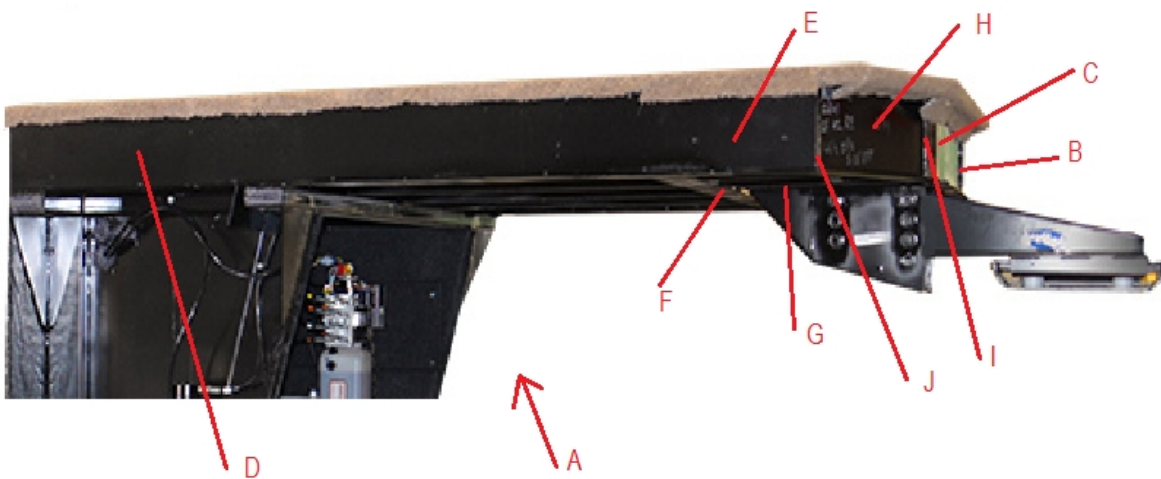

13. In addition to the Luxe Luxury products described above, RV Factory makes, uses, and sells other styles of trailers, which it refers to as Luxe Elite, Luxe Gold, and Weekend Warrior fifth wheels and toy haulers. One example of such products is shown below:



Corresponding equivalent elements for Claim 10 of the '427 patent are designated in this figure for the trailer body K, front portion L, and generally convex forward surface M. In manufacturing such trailer products, RV Factory uses chassis, such as this:



The forward end of that chassis is enlarged below, with the corresponding equivalent elements of Claim 10 of the '427 patent designated therein, as per ¶11 above:

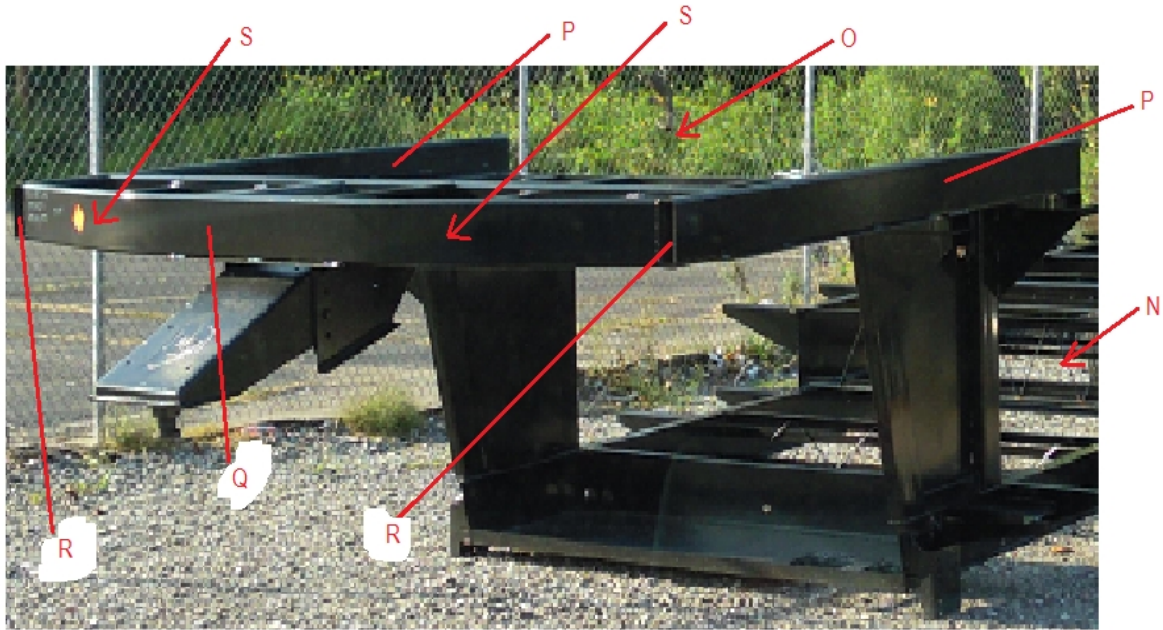

13. Each and every element of at least Claim 1 of the '251 patent is presently either literally or under the “doctrine of equivalents,” as that phrase is understood in the context of U.S. Patent law, in products made, used, and sold by RV Factory. Each and every element of at least Claim 10 of the '427 patent is presently either literally or under the “doctrine of equivalents,” as that phrase is understood in the context of U.S. Patent law, in products made, used, and sold by RV factory. Accordingly, RV Factory is infringing upon the '251 and '427 patents.

14. As made by RV Factory, there is no possible non-infringing use of the accused products. RV Factory sells these infringing products to third parties with the specific intent that those third parties use the infringing products, as made by RV Factory. Those third parties do in fact use the infringing products, and have informed RV Factory of that use, including through warranty claims

and service requests for the accused products which they have purchased. Accordingly, those third parties are also infringing the '251 and '427 patents by their use of the infringing products. As discussed further below, RV Factory has known about the '251 and '427 patents and that Thor considers the accused products to infringe its patents, at least since March 6, 2017. Therefore, RV Factory is contributing to and inducing such infringement by those third party users.

15. RV Factory is a direct competitor of Thor. RV Factory has generated significant revenue and profit for itself by sales of the infringing products. In doing so, RV Factory has deprived Thor of the opportunity to obtain those sales for itself. Accordingly, RV Factory's patent infringement has caused economic damage to Thor, and has provided economic gain for RV Factory. Therefore, RV Factory is liable to Thor for monetary damages and/or a reasonable royalty on account of the patent infringement.

RV Factory's Actions have been Wilful and Deliberate:

16. Upon information and belief, RV Factory acquired all of the assets of Augusta RV, LLC on or about November 9, 2016, and began production of the accused products immediately thereafter. Augusta RV, LLC was licensee of Thor with respect to certain patents, including the '251 patent, and it paid Thor a royalty for its sales of travel trailers using the patented inventions. On several occasions, including March 6, 2017, June 9, 2017, and July 21, 2017, Thor sent correspondence to RV Factory, alerting it of the details of the patent infringement issues and offering to enter into a patent license with RV Factory. Copies of that correspondence are attached hereto as Exhibits 3, 4, and 5.

17. On June 16, 2017, RV Factory responded to Thor's correspondence, declining to enter

into a license agreement. A copy of that correspondence is attached hereto as Exhibit 6. At no time did RV Factory assert that any Thor patent was not considered valid. At no time did RV Factory indicate that it had found any “prior art” reference which provided it a right to use the patented inventions. At no time did RV Factory assert that Thor’s interpretation of the claims was in error or that its chassis were not literally infringing upon Thor patents. At no time did RV Factory have any attorney on its behalf contact Thor with any legal opinion or analysis refuting the infringement claims. Instead, the correspondence by RV Factory indicated that it was making “no claims of an enhanced turning radius” and it had no plans to do so in the future. However, only some, but not all of the claims of the Thor patents which were brought to the attention of RV Factory required the enhanced turning radius feature. Other claims, such as those listed above, defined the chassis structural elements without regard to functionality attributes. RV Factory was silent about why it believed it had no liability for infringing those claims.

18. Finally, on September 28, 2017, Thor wrote to RV Factory with photographic proof that RV Factory was still making infringing travel trailers, through the use of specific chassis frames. A copy of that correspondence is attached hereto as Exhibit 7. At no time did RV Factory respond to that correspondence or offer any refutation of the evidence presented or the conclusions drawn by Thor as to infringement of its patents. Instead, RV Factory appears to have simply ignored the letter.

19. Accordingly, RV Factory is wilfully and deliberately continuing its infringement of the ‘251 and ‘427 patents, without any valid justification or excuse. This infringement is likely to continue unless RV Factory is enjoined from that infringement by this Court.

The Relief Sought:

Accordingly, Thor requests that this Court enter judgement in Thor's favor against RV Factory and Order that:

a. RV Factory (including all those acting in concert with it) is permanently enjoined from infringing the '251 and '427 patents,

b. RV Factory is required to pay money damages to Thor sufficient to compensate Thor for the damages it has suffered as a result of the infringement, or, alternatively, sufficient to remove from RV Factory the monetary gain it has obtained from the infringement, or alternatively, pay a reasonable royalty to Thor on account of the infringement,

c. All infringing products in existence shall be recalled and/or turned over to Thor for destruction,

d. All advertisements and marketing materials describing the infringing products shall be recalled (and/or removed from public access) and turned over to Thor for destruction, and

e. Award Thor all such other relief as is just and appropriate, including for RV Factory's willful infringement, up to triple damages and reasonable attorney fees for this lawsuit.

The Trier of Facts:

Thor requests a trial by jury on all issues so triable.

November 6, 2017

Respectfully submitted,

s/Ryan M. Fountain

Ryan M. Fountain (Attorney No 8544-71)

420 Lincoln Way West
Mishawaka, Indiana 46544
Tel.: 574-258-9296
Fax: 574-247-1237
Email: RyanFountain@aol.com

Attorney for Plaintiff