

UNITED STATES DISTRICT COURT
FOR THE MIDDLE DISTRICT OF GEORGIA
ATHENS DIVISION

MASTERPIECE ARMS HOLDING
COMPANY,

Plaintiff,

v.

McREE’S MULTI SERVICES, LLC,

Defendant.

Civil Action No. _____

COMPLAINT

Plaintiff Masterpiece Arms Holding Company (“Masterpiece Arms”) brings this action against Defendant McRee’s Multi Services, LLC (“MMS” or “Defendant”) and for its Complaint asserts as follows:

INTRODUCTION

1. This is an action for declaratory judgment of non-infringement and invalidity of United States Patent Nos. 9,170,067 (the “’067 patent”) and 9,777,992 (the “’992 patent”), each entitled “Embedded Cant Indicator for Rifles.” True and correct copies of the ’067 and ’992 patents are attached hereto as Exhibits A and B, respectively. The ’067 and ’992 patents are collectively referred to as the “Asserted Patents.”

PARTIES

2. Plaintiff Masterpiece Arms is a Georgia corporation engaged in manufacturing and selling firearms and related accessories, with a principal place of business at 4904 Highway 98 East, Comer, Georgia 30629.

3. Upon information and belief, Defendant MMS is a Mississippi corporation with a principal place of business at 752 CR 174, McCarley, Mississippi 38943.

JURISDICTION AND VENUE

4. On information and belief, MMS is the owner by assignment of the entire right, title and interest to the Asserted Patents.

5. This action arises under the Patent Laws of the United States, 36 U.S.C. §§ 100 *et seq.* and the Declaratory Judgment Act, 28 U.S.C. §§ 2201 and 2202, based on actual justiciable controversy between Masterpiece Arms and MMS. Subject matter jurisdiction over these claims arises under 28 U.S.C. §§ 1331, 1338(a), and 2201.

6. The Court has personal jurisdiction over MMS. On information and belief, MMS has engaged in judicial and extra-judicial patent enforcement conduct asserting the Asserted Patents against Masterpiece Arms, including sending a cease-and-desist letter to MMS alleging infringement of the '067 patent in this

judicial district. MMS has also engaged in patent enforcement conduct against Masterpiece Arms' customers for advertising and selling Masterpiece Arms products, including filing suit against at least one of Masterpiece Arms' distributors, Poway Weapons & Gear, Inc. ("PWG"), alleging that PWG's sales of a Masterpiece Arms product constitutes infringement of the Asserted Patents. On information and belief, MMS also has conducted and conducts business in the State of Georgia.

7. Venue is proper in this District under 28 U.S.C. § 1391 (b) and (c) because substantial parts of the events giving rise to Masterpiece Arms' claims occurred in this District and because MMS is subject to personal jurisdiction in this District.

COUNT I

8. Masterpiece Arms restates and incorporates herein by reference the averments set forth in the preceding paragraphs of this Complaint as if fully rewritten herein.

9. Masterpiece Arms does not infringe and has not infringed, literally or by the doctrine of equivalents, any valid and enforceable claim of the '067 patent either directly, contributorily, by inducement, jointly, or in any other manner.

10. The '067 patent has two independent claims, claims 1 and 7. Claim 1 is an apparatus claim, and requires, *inter alia*, “a solid block having a front side facing toward the rear of the action receiver, a back side contacting the rifle's stock section, a bottom side contacting the rifle's grip section and left and right sides parallel to the centerline axis of the barrel[.]”

11. Although Masterpiece Arms does not infringe claim 1 of the '067 patent for numerous reasons, it does not infringe claim 1 of the '067 patent at least because its products do not have “a solid block having a front side facing toward the rear of the action receiver, a back side contacting the rifle's stock section, a bottom side contacting the rifle's grip section and left and right sides parallel to the centerline axis of the barrel[.]”

12. Claim 7 is a method claim for “compensating for the cant of a rifle having...a centerline mark that is in line with the axis of the barrel” and requires, *inter alia*, the step of “assess[ing] the degree of cant to the rifle by noticing the left or right deviation of the embedded bubble level as shown by the misalignment of the bubble relative to the center line mark[.]”

13. Although Masterpiece Arms does not infringe claim 7 of the '067 patent for numerous reasons, neither Masterpiece Arms nor consumers of its rifles infringe claim 7 of the '067 patent at least because its products do not have “a

centerline mark that is in line with the axis of the barrel” and do not allow a user to “assess the degree of cant to the rifle by noticing the left or right deviation of the embedded bubble level as shown by the misalignment of the bubble relative to the center line mark[.]”

14. Masterpiece Arms, and consumers that use its rifles, also do not infringe any of the dependent claims 2-6 of the '067 patent for at least the same reasons that they do not infringe claim 1 from which they depend.

COUNT II

15. Masterpiece Arms restates and incorporates herein by reference the averments set forth in the preceding paragraphs of this Complaint as if fully rewritten herein.

16. The claims of the '067 patent are invalid for failure to comply with the conditions and requirements of patentability specified in, but not limited to, 35 U.S.C. §§ 101-103, 111-113, and 116 in effect at the time the patent issued.

17. The claims of the '067 patent are invalid at least because they are anticipated by and/or obvious in view of the prior art cited on the face of the patent and/or systems available in the field or some combination thereof. For example, the method of claim 7 of the '067 patent is anticipated by or obvious in view of U.S. Patent No. 9,015,982, which teaches using a bubble-level as a cant indicator

positioned in alignment with the center axis of barrel, such that the shooter is not required to raise his or her cheek from the rifle stock to observe the bubble-level.

COUNT III

18. Masterpiece Arms restates and incorporates herein by reference the averments set forth in the preceding paragraphs of this Complaint as if fully rewritten herein.

19. Masterpiece Arms does not infringe and has not infringed, literally or by the doctrine of equivalents, any valid and enforceable claim of the '992 patent either directly, contributorily, by inducement, jointly, or in any other manner.

20. The '992 patent has two independent claims, claims 1 and 8. Claim 1 is an apparatus claim, and requires, *inter alia*, “a cavity positioned within the forward end of the rifle’s stock section....”

21. Although Masterpiece Arms does not infringe claim 1 of the '992 patent for numerous reasons, it does not infringe claim 1 of the '992 patent at least because its products do not have “a cavity positioned within the forward end of the rifle’s stock section....”

22. Claim 8 is also an apparatus claim that requires “a cavity bored within the forward end of the stock....”

23. Although Masterpiece Arms does not infringe claim 8 of the '992 patent for numerous reasons, it does not infringe claim 1 of the '992 patent at least because its products do not have “a cavity bored within the forward end of the stock....”

24. Masterpiece Arms, and consumers that use its rifles, also do not infringe any of the dependent claims 2-7 of the '992 patent for at least the same reasons that they do not infringe claim 1 from which they depend.

COUNT VI

25. Masterpiece Arms restates and incorporates herein by reference the averments set forth in the preceding paragraphs of this Complaint as if fully rewritten herein.

26. The claims of the '992 patent are invalid for failure to comply with the conditions and requirements of patentability specified in, but not limited to, 35 U.S.C. §§ 101-103, 111-113, and 116 in effect at the time the patent issued.

27. The claims of the '992 patent are invalid at least because they are anticipated by and/or obvious in view of the prior art cited on the face of the patent and/or systems available in the field or some combination thereof.

28. For example, each claim of the '992 is anticipated by the '067 patent, which is prior art to the '992 patent and shares the same disclosure as the '992 patent.

29. Each claim of the '992 patent is also invalid as indefinite and failing to meet the written description requirement under 35 U.S.C. § 112.

30. Each claim of the '992 patent is indefinite for failing to particularly point out and distinctly claim the invention sufficient to inform those skilled in the art of firearms about the scope of the claimed invention with reasonable certainty. Specifically, the term “stock” as used in the specification and in each of the claims is so unclear as to preclude those skilled in the art of firearms from understanding the scope of the claims with reasonable certainty.

31. Each claim of the '992 patent is invalid for failing to meet the written description requirement because each patent claim requires “an action receiver section attached to the forward end of the stock section” (claims 1-7) or a “stock section having a forward end for attaching an action receiver and barrel” (claim 8), and “a cavity...within the forward end of the stock” that holds a “tubular bubble level” (all claims). The '992 patent identifies the “stock section” of the rifle with the part number 1 in Figure 1, with the cant indicator 20 located at the “back end” of the stock. Figure 1 of the '992 patent is reproduced here:

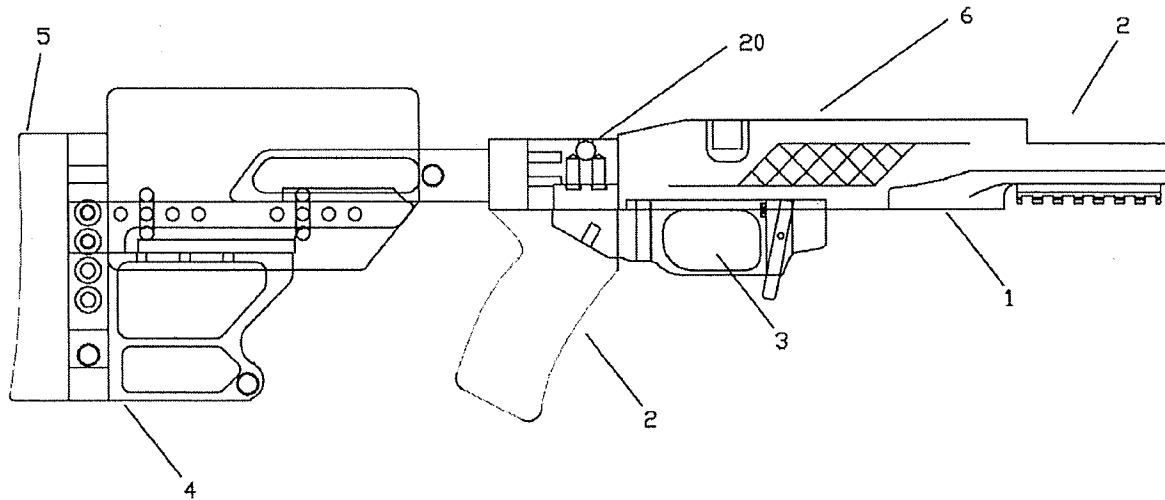

FIG. 1

32. Nowhere does the '992 patent disclose locating “a cavity...within the *forward* end of the stock” that holds a “tubular bubble level”; it only teaches such a cavity at the “back end” of the stock. Consequently, each of the claims of the '992 patent is invalid for failure to meet the written description requirement.

PRAYER FOR RELIEF

Wherefore, Masterpiece Arms Holding Company prays that this Court enter judgment:

- A. declaring that Masterpiece Arms Holding Company does not directly, jointly, or indirectly infringe any valid claim of the '067 patent by the use, sale, or offer for sale of any of its products or any other activity

attributable to Masterpiece Arms Holding Company, either literally or under the doctrine of equivalents;

B. declaring that Masterpiece Arms Holding Company does not directly, jointly, or indirectly infringe any valid claim of the '992 patent by the use, sale, or offer for sale of any of its products or any other activity attributable to Masterpiece Arms Holding Company, either literally or under the doctrine of equivalents;

C. declaring that the claims of the '067 patent are invalid;

D. declaring that the claims of the '992 patent are invalid;

E. declaring that this case is “exceptional” within the meaning of 35 U.S.C. § 285, and that all costs and expenses of this action, including reasonable attorneys’ fees, be awarded to Masterpiece Arms Holding Company.

JURY DEMAND

Pursuant to Fed. R. Civ. P. 38(b), Masterpiece Arms Holding Company demands trial by jury on all issues so triable by right to a jury in this matter.

This 13th day of November, 2017.

MILLER & MARTIN PLLC

/s/ Ryan A. Kurtz

Ryan A. Kurtz

Ryan.Kurtz@millermartin.com

Georgia Bar No. 430484

1180 W. Peachtree Street NW

Suite 2100

Atlanta, GA 30309

404-962-6100/404-962-6300 (fax)

and

Of Counsel:

WORKMAN NYDEGGER

Robyn Phillips (Utah Bar No. 07425)

rphillips@wnlaw.com (*pro hac vice
forthcoming*)

Chad E. Nydegger (Utah Bar No. 09964)

cnydegger@wnlaw.com (*pro hac vice
forthcoming*)

60 East South Temple, Suite 1000

Salt Lake City, UT 84111

Telephone: (801) 533-9800

Facsimile: (801) 328-1707

*Attorneys for Plaintiff Masterpiece Arms
Holding Company*