

**IN THE UNITED STATES DISTRICT COURT
FOR THE SOUTHERN DISTRICT OF NEW YORK**

AUTEL ROBOTICS USA LLC,)	
)	
Plaintiff,)	
)	
v.)	JURY TRIAL DEMANDED
)	
DJI TECHNOLOGY INC.,)	
SZ DJI TECHNOLOGY CO., LTD. AND)	
DJI EUROPE B.V.)	
)	
Defendants.)	
)	

COMPLAINT FOR PATENT INFRINGEMENT

Plaintiff Autel Robotics USA LLC (“Autel”), by and through their attorneys, hereby file this Complaint against Defendants DJI Technology Inc. (“DJI USA”), SZ DJI Technology Co., Ltd. (“SZ DJI”) and DJI Europe B.V. (“DJI Europe) (collectively, “DJI”) and allege as follows:

NATURE OF THE ACTION

1. This is a patent infringement action to end DJI’s unauthorized and infringing manufacture, use, sale, offering for sale, and/or importation of methods and products incorporating Autel’s intellectual property.

PARTIES

2. Plaintiff Autel Robotics USA LLC is a Delaware limited liability company with a principal place of business at 22522 29th Dr. SE I101, Bothell, Washington.

3. Defendant DJI Technology Inc. is a California corporation with its principal place of business at 201 S. Victory Blvd, Burbank, California 91503. DJI Technology Inc. is registered with the New York Department of State (DOS ID# 512262) and has a regular and established place of business at 632 Broadway, New York, New York 10012.

4. Defendant SZ DJI Technology Co., Ltd. is a Chinese corporation with its principal place of business at 14th Floor, West Wing, Skyworth Semiconductor Design Building, No. 18 Gaoxin South 4th Ave, Nanshan District, Shenzhen, China. On information and belief, SZ DJI is responsible for the research and development of DJI-branded products sold in the United States.

5. Defendant DJI Europe B.V. is a European corporation with its principal place of business as Bijdorp-Oost 6, 2992 LA Barendrecht, Netherlands. On information and belief, DJI Europe is responsible for the sales of DJI-branded products in the United States.

JURISDICTION AND VENUE

6. This action arises under the Patent Act, Title 35 of the United States Code.

7. This Court has subject matter jurisdiction pursuant to 28 U.S.C. §§ 1331 and 1338.

8. This Court has personal jurisdiction over DJI Technology Inc. because it is registered with the New York Department of State (DOS ID# 512262) and has a regular and established place of business at 632 Broadway, New York, New York 10012.

9. This Court has personal jurisdiction over DJI because, directly or through an intermediary or agent, each Defendant has committed acts within New York giving rise to this action and has established minimum contacts with New York such that the exercise of jurisdiction would not offend traditional notions of fair play and substantial justice. Each Defendant knowingly introduces into the stream of commerce products and/or components of products that infringe the Patents-in-Suit, and each Defendant knew and intended that such products would be used in this District.

10. For example, Defendants have partnered with New York local consumer electronics retailer Camrise to promote an “Official DJI Store in NYC.” Defendants’ partnership with Camrise includes the sales of their infringing products and components both in retail stores located at 1666 Broadway and 300 W 49th St, New York, NY 10019 and online stores including, but not limited to, a co-branded website, “DJI NYC by Camrise,” available at www.djiny.com.

11. On information and belief, SZ DJI designs and manufactures the infringing products and places them into the stream of commerce via an established distribution channel with the knowledge and expectation that such products would be sold in this District. DJI’s website says “[h]eadquartered in Shenzhen, widely considered China’s Silicon Valley, DJI benefits from direct access to the suppliers, raw materials, and young, creative talent pool necessary for sustained success.” In addition, it says “our wholly owned subsidiary Shenzhen Dajiang Baiwang Technology Co., Ltd. is a high-tech manufacturing facility specializing in unmanned aerial vehicles.”

12. On information and belief, DJI Europe sells the infringing products in US, including within this District. In addition, DJI Europe provides services in the field of logistics, storage and transportation and acts as a global distribution center.

13. On information and belief, all Defendants act in concert as a single entity to develop, manufacture, distribute, import, offer to sell and sell infringing products in this case. Each Defendant has derived substantial revenues from its infringing acts in this District.

14. On information and belief, DJI has also knowingly induced infringement by others within the United States and this District by advertising, marketing, offering for sale, and selling devices containing infringing functionality to consumers, customers, distributors, resellers, partners, and end users in the United States, and by providing instructions, user

manuals, advertising, and marketing materials which facilitate, direct, or encourage the use of infringing functionality with knowledge thereof.

15. Venue is proper for SZ DJI and DJI Europe under 28 U.S.C. § 1391 and 28 U.S.C. § 1400(b) because SZ DJI and DJI Europe knowingly introduce into the stream of commerce infringing products to serve not only the US market generally, but also the market in this District specifically.

16. Venue is proper for DJI Technology Inc. under 28 U.S.C. § 1400(b) because it has a regular and established place of business at 632 Broadway, New York, New York 10012.

THE ASSERTED PATENTS

17. This lawsuit asserts causes of action for infringement of United States Patent Nos. 7,979,174 (the '174 patent) and 9,260,184 (the '184 patent) (collectively, "the Asserted Patents"). Autel is the owner of all rights, title, and interest in and to the Asserted Patents.

18. The '174 patent, entitled "Automatic Planning and Regulation of the Speed of Autonomous Vehicles," was duly and lawfully issued by the U.S. Patent and Trademark Office (USPTO) on July 12, 2011. A true and correct copy of the '174 patent is attached hereto as Exhibit A.

19. One of the features of the unmanned aerial vehicles (UAVs) is the ability to fly along a predetermined path at a predetermined speed. The UAV does this by accepting a flight path from a user, and then by using sensors to make sure that the UAV stays on the predetermined path at a determined speed by taking the inputs from the sensors, such as the strength of headwinds and/or tailwinds, and accordingly adjusting the speed of the actuators

spinning the rotors to adjust the speed of the UAV. Figure 1 of the '174 patent illustrates this process and has been reproduced below:

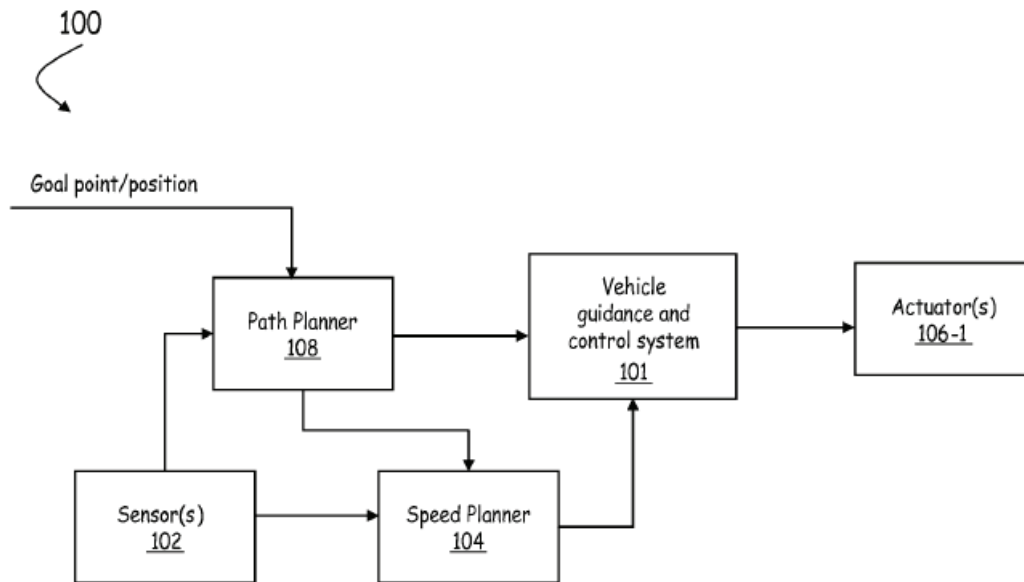

FIG. 1

Figure 1. Fig. 1 of the '174 Patent

20. The '184 patent, entitled "Compact Unmanned Rotary Aircraft," was duly and lawfully issued by the USPTO on February 16, 2016. A true and correct copy of the '184 patent is attached hereto as Exhibit B.

21. For stability of a multi-rotor unmanned aerial vehicle (UAV), it is important to have different rotors operate in different directions, both clockwise and counterclockwise. Because of this requirement, a quadcopter must have two clockwise spinning rotors and two counterclockwise spinning rotors, which will negate the torque being placed on the UAV by the spinning rotors, which will lead to the stability of the craft. Figure 1 of the '184 patent depicts the rotation of the rotors and has been reproduced below:

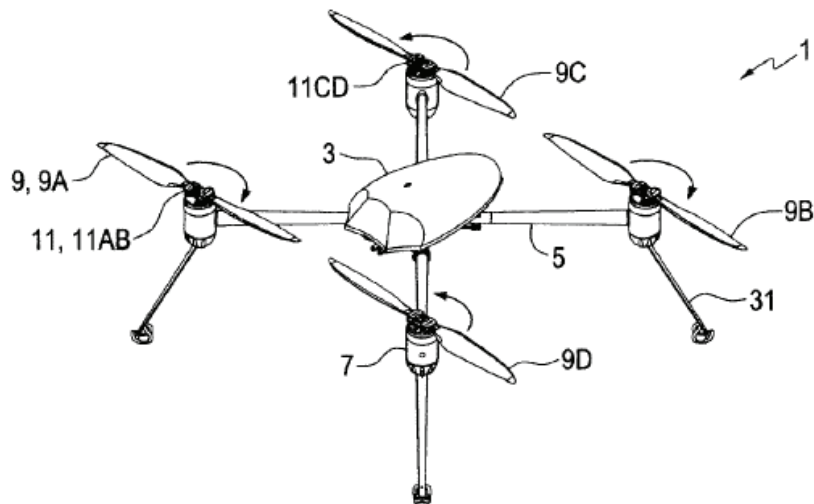

FIG. 1

Figure 2. Fig. 1 of the '184 Patent

22. The '184 patent is generally directed to a UAV with rotors that can be removably coupled to the UAV through a clockwise/counterclockwise locking mechanism that only allows the correct rotor to be attached to the corresponding electric motor of the UAV. This allows the rotors configured to spin clockwise to only be able to lock to the UAV motors configured to spin rotors clockwise, and allows the rotors configured to spin counterclockwise to only be able to lock to the UAV motors configured to spin rotors counterclockwise. Figures 6, 7, and 8 of the '184 patent illustrate this one-way locking mechanism and have been reproduced below:

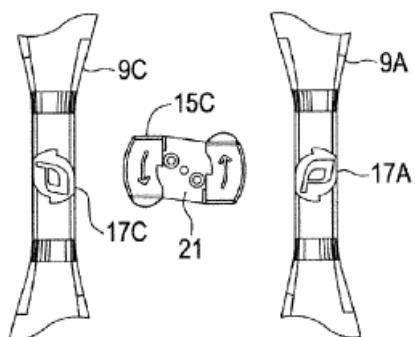

FIG. 6

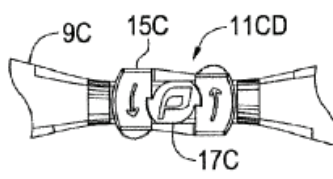

FIG. 7

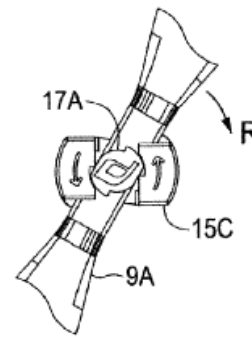

FIG. 8

THE ACCUSED PRODUCTS

23. Defendants DJI USA, SZ DJI and DJI Europe manufacture and sell UAV products throughout the world, including within the United States and this District. These products currently include at least four different series of products, as illustrated in the chart below (collectively, “the Accused Products”):¹

UAV Series	Products within the Series
Mavic Series	Mavic Air, Mavic Pro, Mavic Pro Platinum
Spark Series	Spark
Phantom Series	Phantom 3 SE, Phantom 4 Pro, Phantom 4 Advanced
Inspire Series	Inspire 2

¹ See dji.com

24. A photographic example of each product series has been produced below:



Figure 3. DJI Mavic



Figure 4. DJI Spark



Figure 5. DJI Phantom 4



Figure 6. DJI Inspire 2

25. Each series of products manufactured and sold by DJI includes each and every element of at least claim 1 of the '174 patent.

26. Claim 1 of the '174 patent has been reproduced below:

1. An autonomous vehicle comprising:
 - one or more sensors configured to obtain data regarding conditions which affect movement of the autonomous vehicle;
 - a speed planner coupled to the one or more sensors and configured to calculate a desired speed based, at least in part, on the data obtained from the one or more sensors;
 - a control system configured to calculate speed commands based, at least in part, on the speed calculated by the speed planner; and
 - one or more actuators configured to adjust the speed of the autonomous vehicle based on the speed commands from the control system;wherein the speed planner is further configured to output a speed command category associated

with the desired speed.

27. Each of the Accused Products is an autonomous vehicle comprising one or more sensors configured to obtain data regarding conditions which affect its movement and includes a speed planner coupled to the one or more sensors and configured to calculate a desired speed based in part on the data obtained from the one or more sensors. The Accused Products implement a speed planner coupled to the one or more sensors through obstacle avoidance and automatic braking. This allows the Accused Products to slow their forward progress when an obstacle is sensed by UAV.

28. The Mavic Pro includes “Assisted Braking from Forward Vision System” which allows the UAV to brake when it senses an object ahead of it:

Assisted Braking from Forward Vision System

Powered by the Forward Vision System, the aircraft is able to actively brake when obstacles are detected in front. Forward and Downward Vision Systems work best when lighting is adequate and the obstacle is clearly marked or textured. The aircraft must fly at no more than 22mph (36kph) to allow sufficient braking distance.

29. The Spark also includes a form of intelligent braking:

Powered by the 3D Sensing System, the aircraft is able to actively brake when obstacles are detected in front. The 3D Sensing System works best when lighting is adequate and the obstacle is clearly marked or textured. The aircraft must fly at no more than 6.7 mph (10.8 kph) to allow for sufficient braking distance.

30. The Phantom describes its intelligent braking system as “Assisted Braking from Obstacle Sensing”:

Assisted Braking from Obstacle Sensing

Powered by the Obstacle Sensing, the aircraft will now be able to actively brake when obstacles are detected around the aircraft. Note that Obstacle Sensing function works best when lighting is adequate and the obstacle is clearly marked or textured. The aircraft must fly at no more than 31mph (50kph) to allow sufficient braking distance.

31. The Inspire 2 also refers to its intelligent braking as “Assisted Braking from Obstacle Sensing”:

Assisted Braking from Obstacle Sensing

Powered by the Obstacle Sensing, the aircraft will now be able to actively brake when obstacles are detected around the aircraft. Note that Obstacle Sensing function works best when lighting is adequate and the obstacle is clearly marked or textured. The aircraft must fly at no more than 31mph (50kph) to allow sufficient braking distance.

32. Each of the Accused Products includes a control system configured to calculate speed commands based in part on the speed calculated by the speed planner. Additionally, the Accused Products include one or more actuators configured to adjust the speed of the autonomous vehicle based on the speed commands from the control system wherein the speed planner is further configured to output a speed command category associated with the desired speed. The Accused Products perform this step through their respective flight control modules, which take the inputs from the obstacle avoidance systems and speed planners and outputs speed commands to the electronic speed control (ESC) systems controlling each of the rotors.

33. Each of the Accused Products manufactured and sold by DJI includes each and every element of at least claim 1 of the '184 patent.

34. Claim 1 of the '184 patent has been reproduced below:

1. A rotary wing aircraft apparatus comprising:
a body;
a plurality of arms extending laterally from the body, and a rotor assembly attached to an outside end of each arm;
each rotor assembly comprising a rotor blade releasably attached to a driveshaft by a lock mechanism, and a drive rotating the driveshaft;
wherein a first driveshaft rotates in a clockwise direction and a second driveshaft rotates in a counterclockwise direction;
wherein a clockwise rotor blade is releasably attached to the first driveshaft by engagement in a clockwise lock mechanism and generates a vertical lift force when rotated in the clockwise direction, and a counterclockwise rotor blade is releasably attached to the second driveshaft by engagement in a counterclockwise lock mechanism and generates a lift force when rotated in the counterclockwise direction;
wherein the clockwise rotor blade is engageable only with the clockwise lock mechanism and cannot be engaged in the counterclockwise lock mechanism, and the counterclockwise rotor blade is engageable only with the counterclockwise lock mechanism and cannot be engaged in the clockwise lock mechanism; and
wherein the clockwise lock mechanism comprises a shaft lock portion attached to the first

driveshaft and a blade lock portion attached to the clockwise rotor blade, the shaft lock portion defining notches configured to engage corresponding lugs on the blade lock portion.

35. Each of the Accused Products includes a body with a plurality of arms extending laterally from the body with a rotor assembly attached to an outside end of each arm. This can be seen in Figures 1–4 above.

36. Each of the Accused Products includes a rotor assembly comprising a rotor blade releasably attached to a driveshaft by a lock mechanism with a drive rotating the driveshaft, one of which is rotating in a clockwise direction and another of which is rotating in a counterclockwise direction, both of which generate lift force when rotated in their respective directions.

37. The specific directionality of the rotors is shown in the Mavic Pro User Manual, but is representative of all of the Accused Products:

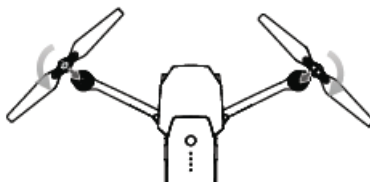



38. Each of the Accused Products includes a lock mechanism that selectively allows the correct rotor to engage with its corresponding driveshaft—clockwise rotor to clockwise driveshaft and counterclockwise rotor to counterclockwise driveshaft.



39. The Mavic Pro utilizes “white rings” on its rotors to distinguish between those that go clockwise and those that go counterclockwise:

Attaching and Detaching the Propellers





Use only DJI approved propellers with your Mavic Pro. White ring and unmarked propellers indicate where they should be attached and in which direction they should spin.

Propellers	White Ring	Unmarked
Figure		
Attach On	Motors with white marks	Motors without white marks
Legends	 Lock : Turn the propellers in the indicated direction to mount and tighten.	

40. The Spark User Manual includes a similar graphic as it also utilizes white rings to differentiate between the rotors that are configured to spin clockwise and those that are configured to spin counterclockwise:

Propellers	White Ring	Unmarked
Figure		
Attach On	Motors with white marks	Motors without white marks
Legend	 Lock : Turn the propellers in the indicated direction to mount and tighten.	

41. The Phantom 4 differentiates between clockwise and counterclockwise rotors by using silver and black rings with black dots:

Propellers	Silver Ring	Black Ring
Figure		
Attach On	Motors without black dots	Motors with black dots
Legends	 Lock : Turn the propellers in the indicated direction to mount and tighten.  Unlock : Turn the propellers in the indicated direction to loosen and remove.	

42. The Inspire 2 User Manual differentiates between clockwise and counterclockwise motors by the motor/rotor colors as well:

1. Pair the propellers and motors with arrows of the same color (red or white).

43. Each of the Accused Products includes a lock mechanism that has a shaft lock portion attached to the first driveshaft and a blade lock portion attached to the clockwise rotor blade, the shaft lock portion defining notches configured to engage corresponding lugs on the blade lock portion.

44. The Mavic Pro User Manual clearly shows the notches of the shaft lock portion and the lugs on the blade lock portion:



45. The Spark User Manual also clearly shows the notches of the shaft lock portion and the lugs on the blade lock portion:

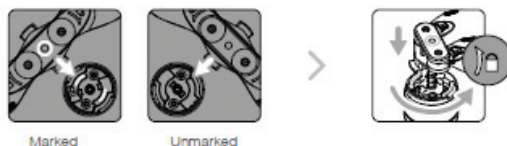

46. The Phantom 4 User Manual also shows the notches that would attach to the lugs on the blade lock portion:



47. The Inspire 2 User Manual also shows the notches and lugs:

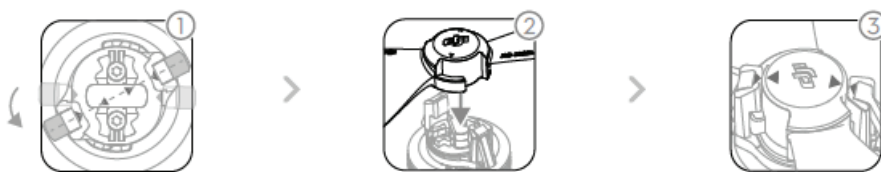

COUNT I – INFRINGEMENT OF US PATENT NO. 7,979,174

48. Autel incorporates each of the preceding paragraphs as if fully set forth herein.

49. Without license or authority and in violation of 35 U.S.C. § 271(a), Defendants make, use, offer to sell, and/or sell within the United States and/or import into the United States the Accused Products, which include each and every element, either literally or under the Doctrine of Equivalents, of at least claim 1 of the '174 patent.

50. Without license or authority and in violation of 35 U.S.C. § 271(b), Defendants actively induce the making, using, offering to sell, and/or selling within the United States and/or importing into the United States the Accused Products, which include each and every element, either literally or under the Doctrine of Equivalents, of at least claim 1 of the '174 patent.

51. Without license or authority and in violation of 35 U.S.C. § 271(c), Defendants offer to sell, sell, and/or import into the United States a component of a patented apparatus constituting a material part of the invention, knowing the same to be especially made or especially adapted for use in an infringement of such patent and which is not a staple article or commodity of commerce for substantial noninfringing use.

52. DJI's infringement of the '174 patent has caused and will continue to cause Autel irreparable injury and harm for which there is no adequate remedy at law unless and until DJI is permanently enjoined by this Court from infringing the '174 patent.

53. Autel is entitled to recover from Defendants the damages it has sustained as a result of Defendants' infringing activities in an amount subject to proof at trial, including but not limited to lost profits and not less than a reasonable royalty, together with interest as costs as fixed by this Court under 35 U.S.C. § 284.

54. This is an exceptional case under 35 U.S.C. § 285, and Autel is entitled to enhanced damages, attorneys' fees, and litigation expenses incurred.

COUNT II – INFRINGEMENT OF US PATENT NO. 9,260,184

55. Autel incorporates each of the preceding paragraphs as if fully set forth herein.

56. Without license or authority and in violation of 35 U.S.C. § 271(a), Defendants make, use, offer to sell, and/or sell within the United States and/or import into the United States

the Accused Products, which include each and every element, either literally or under the Doctrine of Equivalents, of at least claim 1 of the '174 patent.

57. Without license or authority and in violation of 35 U.S.C. § 271(b), Defendants actively induce the making, using, offering to sell, and/or selling within the United States and/or importing into the United States the Accused Products, which include each and every element, either literally or under the Doctrine of Equivalents, of at least claim 1 of the '174 patent.

58. Without license or authority and in violation of 35 U.S.C. § 271(c), Defendants offer to sell, sell, and/or import into the United States a component of a patented apparatus constituting a material part of the invention, knowing the same to be especially made or especially adapted for use in an infringement of such patent and which is not a staple article or commodity of commerce for substantial noninfringing use.

59. DJI's infringement of the '174 patent has caused and will continue to cause Autel irreparable injury and harm for which there is no adequate remedy at law unless and until DJI is permanently enjoined by this Court from infringing the '174 patent.

60. Autel is entitled to recover from Defendants the damages it has sustained as a result of Defendants' infringing activities in an amount subject to proof at trial, including but not limited to lost profits and not less than a reasonable royalty, together with interest as costs as fixed by this Court under 35 U.S.C. § 284.

61. This is an exceptional case under 35 U.S.C. § 285, and Autel is entitled to enhanced damages, attorneys' fees, and litigation expenses incurred.

DEMAND FOR JUDGMENT

WHEREFORE, Autel requests the following relief:

1. A judgment that DJI's making, using, offering to sell, selling within, and/or importing to the Southern District of New York and elsewhere in the United States, the Accused Products infringes one or more claims of the Asserted Patents, in violation of 35 U.S.C. § 271(a);

2. A judgment that DJI's active inducement of others to make, use, offer to sell, sell, and/or import into the Southern District of New York and elsewhere in the United States, the Accused Products infringes one or more claims of the Asserted Patents, in violation of 35 U.S.C. § 271(b);

3. A judgment that DJI's offering to sell or selling components of a patented invention in the Southern District of New York and elsewhere in the United States, the Accused Products infringes one or more claims of the Asserted Patents, in violation of 35 U.S.C. § 271(c);

4. A judgment that DJI has willfully infringed the Asserted Patents;

5. An award of damages adequate to compensate for DJI's infringement of the claims of the Asserted Patents under 35 U.S.C. § 284, together with interest and costs as fixed by the Court;

6. An award of enhanced damages against DJI for the willful infringement of the Asserted Patents;

7. A determination that this is an exceptional case within the meaning of 35 U.S.C. § 285, and an award of Autel's reasonable attorneys' fees;

8. An injunction, pursuant to 35 U.S.C. §283, permanently prohibiting Defendants from infringing any claims of the Asserted Patents prior to the latest expiration date of the patents, including any extensions;

9. Such other costs and further relief as the Court deems just and proper.

JURY DEMAND

Pursuant to Rule 38(b) of the Federal Rules of Civil Procedure, Autel requests a trial by jury on all triable issues.

Dated: April 25, 2018

STEPTOE & JOHNSON LLP

By: 

Evan Glassman
1114 Avenue of the Americas
New York, NY 10036
(212) 506-3900

Timothy C. Bickham
(*Pro hac vice* application to be
submitted)
1330 Connecticut Avenue, N.W.
Washington, D.C. 20036
(202) 429-3000

*Attorneys for Plaintiff
Autel Robotics USA LLC*