

**IN THE UNITED STATES DISTRICT COURT
FOR THE EASTERN DISTRICT OF TEXAS
TYLER DIVISION**

CHROMAR SYSTEMS, INC.,
d/b/a CMS TECHNOLOGIES and
CHROMAR HOLDING COMPANY, LLC,

Plaintiffs,

v.

ANIXTER INC.,
Defendant.

Civil Action No. 6:18-cv-248

JURY TRIAL DEMANDED

COMPLAINT FOR PATENT INFRINGEMENT

Plaintiffs Chromar Systems, Inc. d/b/a CMS Technologies (“Chrimar Systems”) and Chromar Holding Company, LLC (“Chrimar Holding”) (collectively, “Chrimar” or “Plaintiffs”) file this Complaint against Defendant Anixter Inc. (“Defendant”) for infringement of U.S. Patents Nos. 8,942,107, 9,812,825, 8,902,760, and 9,019,838, and hereby allege as follows:

NATURE OF THE ACTION

1. This is an action for patent infringement arising under the Patent Laws of the United States, 35 U.S.C. §§ 1, *et seq.*

PARTIES

2. Plaintiff Chromar Systems, Inc. d/b/a CMS Technologies is a Michigan corporation with a place of business located at 36528 Grand River Avenue, Suite A-1, Farmington Hills, Michigan 48335.

3. Plaintiff Chromar Holding Company, LLC is a Texas limited liability company with a place of business located at 911 NW Loop 281, Suite 211-30, Longview, Texas 75604.

4. Chrimar was the first company to employ DC current within a BaseT network in the early 1990s and has received a number of US patents for this very important technology. Chrimar continues to market its EtherLock® family of products for asset control, management and security, including the including the EtherLock® II and EtherLock IDentification (ELID) products:

EtherLock® II

EtherLock® II is a centralized piece of equipment which applies DC current to the physical layer, to continuously monitor the physical connection, receive distinguishing information about Ethernet end devices and provide notification, etc.



ELID

The EtherLock IDentification device or ELID device works in conjunction with the EtherLock II unit allowing for real-time identification and tracking of a computers' physical location on an Ethernet network providing absolute control over what equipment connects to your data network. The ELID device also allows for a complete location-based inventory of all your assets even if the assets are powered off.



http://cmstech.com/security_solutions/products/products.html

5. Chrimar's EtherLock® II product practices certain claims of the `838 Patent, and the installed ELID/NIC-Stick circuitry practice certain claims of the `107, `760, and `825 Patents. *See also* <http://www.cmspatents.com/>.

6. Chrimar has entered into numerous non-exclusive licenses for certain equipment under certain Chrimar patents including certain Power over Ethernet (PoE) equipment designed for deployment within a BaseT Ethernet network. *See, e.g.,* <https://realtimepressrelease.com/press-releases-tagged-with/chrimar/>.

7. Upon information and belief, Defendant Anixter Inc. is a Delaware corporation having a place of business at 2301 Patriot Blvd Glenview, IL 60026-8020, and can be served

through its registered agent, Corporation Service Company D/B/A CSC-Lawyers Inc., 211 E. 7th Street, Suite 620 Austin, TX 78701.

JURISDICTION AND VENUE

8. This Court has subject matter jurisdiction under 28 U.S.C. §§ 1331 and 1338(a).

9. Defendant is subject to this Court's specific and general personal jurisdiction due to its substantial business in this forum. For example, upon information and belief, Defendant is subject to the specific personal jurisdiction of this Court because Chrimar's claims for patent infringement arise from Defendants' acts of infringement in the State of Texas. These acts of infringement include selling infringing products in the State of Texas and placing infringing products into the stream of commerce through an established distribution channel with full awareness that substantial quantities of the products have been shipped into the State of Texas. Therefore, this Court has personal jurisdiction over Defendant under the Texas long-arm statute, TEX. CIV. PRAC. & REM. CODE § 17.042.

10. Venue is proper in this judicial district under 28 U.S.C. § 1400(b). Defendant has a regular and established places of business in this District at 2800 Quail Run, Suite 100, Corinth, TX 76208; 1601 Waters Ridge Dr., Lewisville, TX 75057; 1201 LAKESIDE PKWY Flower Mound, TX and 1605 Crescent Circle, Suite 300, Carrollton, TX 75006, and has committed and continues to commit acts of infringement in this District. For example, Defendant's regular and established place of business in Corinth in this District is a physical building, depicted below, and according to the Denton County Central Appraisal District is 100% owned by Anixter Inc. *See In re Cray Inc.*, 871 F.3d 1355, 1360 (Fed. Cir. 2017).



General Information

2800 QUAIL RUN TX

\$15,144,431.00

Unit 100

Owner	ANIXTER, INC ^Q - 100%
Owner ID	922662
Owner Mailing Address	ATTN STEPHANIE MORGAN TAX 1N 2301 PATRIOT BLVD GLENVIEW, IL 60026-8020
Doing Business As	ANIXTER POWER SOLUTIONS, LLC
Property Type	Personal Property
Legal Description	PERSONAL PROPERTY - CONSTRUCTION MATERIALS LOCATION: 2800 QUAIL RUN STE 100, CORINTH
Taxing Jurisdictions	C04 (CORINTH CITY OF) S08 (LAKE DALLAS ISD) G01 (DENTON COUNTY)

[Direct Link to this Property](#)
[Rendition Form](#)
[Download Appraisal Notice](#)

<https://www.dentoncad.com/home/details?search=680095&year=2018>.

11. Likewise, Defendant’s regular and established place of business in Lewisville in this District is a physical building, depicted below, and according to the Denton County Central Appraisal District is 100% owned by Anixter Inc.



General Information

1601 WATERS RIDGE DR TX 75057-6013

\$23,437,435.00

Owner	ANIXTER INC ^Q - 100%
Owner ID	338298
Owner Mailing Address	C/O TAX DEPARTMENT 2301 PATRIOT BLVD GLENVIEW, IL 60026-8020
Doing Business As	ANIXTER INC
Property Type	Personal Property
Legal Description	PERSONAL PROPERTY - TELECOMMUNICATIONS PRODS MFG LOCATION: 1601 WATERS RIDGE RD, LEWISVILLE
Geographic ID	P921434
Taxing Jurisdictions	S09 (LEWISVILLE ISD) C12 (LEWISVILLE CITY OF) G01 (DENTON COUNTY)

- [Direct Link to this Property](#)
- [View on map](#)
- [Rendition Form](#)
- [Download Appraisal Notice](#)

<https://www.dentoncad.com/home/details?search=921434&year=2018>.

12. Likewise, Defendant's regular and established place of business in Flower Mound in this District is a physical building, and, according to the Denton County Central Appraisal District, is 100% owned by Anixter Inc.

General Information	
1201 LAKESIDE PKWY TX	\$40,574.00
Unit 160	
Owner	ANIXTER INC - 100%
Owner ID	894749
Owner Mailing Address	TAX DEPT - 1N 2301 PATRIOT BLVD GLENVIEW, IL 60026-8020
Doing Business As	ANIXTER INC
Property Type	Personal Property
Legal Description	PERSONAL PROPERTY - CONSIGNED INVENTORY @ WHITLOCK LOCATION: 1201 LAKESIDE PKWY STE 160, FLOWER MOUND
Taxing Jurisdictions	C07 (FLOWER MOUND TOWN OF) S09 (LEWISVILLE ISD) G01 (DENTON COUNTY)
	Direct Link to this Property Rendition Form Download Appraisal Notice

<https://www.dentoncad.com/home/details?search=659946&year=2018>.

PATENTS-IN-SUIT

13. Chrimar Systems is the owner and the assignee of U.S. Patent No. 8,942,107 (the “107 Patent”), entitled “Piece of Ethernet Terminal Equipment” and Chrimar Holding holds the exclusive right to license the `107 Patent. Chrimar has ownership of all substantial rights in the `107 Patent, including the right to exclude others and to enforce, sue and recover damages for past and future infringement. A true and correct copy of the `107 Patent is attached as Exhibit A.

14. The `107 Patent is valid, enforceable and was duly issued in full compliance with Title 35 of the United States Code.

15. Chrimar Systems is the owner and assignee of U.S. Patent No. 9,812,825 (the “825 Patent”), entitled “Ethernet Device” and Chrimar Holding holds the exclusive right to license the `825 Patent. Chrimar has ownership of all substantial rights in the `825 Patent, including the right to exclude others and to enforce, sue and recover damages for past and future infringement. A true and correct copy of the `825 Patent is attached as Exhibit B.

16. The `825 Patent is valid, enforceable and was duly issued in full compliance with Title 35 of the United States Code.

17. Chrimar Systems is the owner and assignee of U.S. Patent No. 8,902,760 (the “760 Patent”), entitled “Network System and Optional Tethers” and Chrimar Holding holds the exclusive right to license the `760 Patent. Chrimar has ownership of all substantial rights in the `760 Patent, including the right to exclude others and to enforce, sue and recover damages for past and future infringement. A true and correct copy of the `760 Patent is attached as Exhibit C.

18. The `760 Patent is valid, enforceable and was duly issued in full compliance with Title 35 of the United States Code.

19. Chrimar Systems is the owner and the assignee of U.S. Patent No. 9,019,838 (the “838 Patent”), entitled “Central Piece of Network Equipment” and Chrimar Holding holds the exclusive right to license the `838 Patent. Chrimar has ownership of all substantial rights in the `838 Patent, including the right to exclude others and to enforce, sue and recover damages for past and future infringement. A true and correct copy of the `838 Patent is attached as Exhibit D.

20. The `838 Patent is valid, enforceable and was duly issued in full compliance with Title 35 of the United States Code.

21. The `107, `825, `760, and `838 Patents are collectively the “Patents-in-Suit.”

22. The Patents-in-Suit generally cover plug and play automation and/or asset control capabilities employed by certain BaseT Ethernet equipment including powered devices (“PDs”), power sourcing equipment (“PSEs”), and midspans/injectors that comply with or are compatible with certain portions of the IEEE Standards commonly referred to as PoE Standards (e.g., the IEEE 802.3af or IEEE 802.3at standards).

ACCUSED PRODUCTS

23. Upon information and belief, Defendant makes, uses, offers to sell, sells, and/or imports Power over Ethernet powered devices and/or power sourcing equipment. Defendant’s Accused Products are divisible into two categories.

24. The first category is Accused Powered Devices (“Accused PD Products”). The Accused PDs include devices that receive power via their Ethernet port, such as cameras, speakers, phones, access points, and keypads. Exemplary explanations of how the Accused PDs infringe are provided in the patent specific infringement counts below. Defendant sells Accused PDs from at least the following unlicensed manufacturers: Ascendance Wireless, Inc.; Atlas Sound; Atlona Technologies; Axis Communications; Azco Technologies; Bluewave Security; Bolide Technology Group; Bosch Security Systems; Comnet Communication Networks; Compulan View Technologies; Etherwan Systems; Flir; Geovision; Hikvision; 13 DVR International, Inc.; IC Realtime LLC; Inaxsys-ICT Security Systems; Ingram Micro (Ubiquiti Networks); Inova Solutions; Louroe Electronics; Luxul Wireless; Messoa Technologies; On-Q/Legrand; Openeye; OT Systems; Panduit; Pelco (Schneider Electric Co.); PoE Technologies; Samsung Techwin; Seco-Larm USA, Inc.; Security Door Controls (SDC Security); Toshiba;

Verint Video Solutions, Inc.; Vicon Industries, Inc.; Vitek Industrial Video Product; Weldex Corporation; and Xtralis.

25. The second category is Accused Power Sourcing Equipment (“Accused PSE Products”). The Accused PSEs include devices that provide power to other devices by way of an Ethernet port, such as PoE (Power over Ethernet) switches, midspans/injectors, and network video recorders (“NVRs”). Defendant sells Accused PSEs from at least the following unlicensed manufacturers: AESP, Inc.; Altronix; American Fibertek; Antaira Technologies; Ascendance Wireless, Inc.; Atlona Technologies; Axis Communications; Azco Technologies; BSD Networks; CBC (America) Corp; Comnet Communications Networks; Etherwan Systems; Flir; Geovision; Hikvision; 13 DVR International, Inc.; IC Realtime LLC; Inaxsys-ICT Security Systems; Ingram Micro (Ubiquiti Networks); Interlogix (United Technologies); KBC Networks; Lan Power Systems; Luxul Wireless; Meridian Technologies; On-Q/Legrand; Openeye; OT Systems; Panduit; (P3) Preferred Power Products; Razberi Technologies; Speco Technologies; Veracity; Vigitron, Inc.; Vitek Industrial Video Product; Vivotek; and Zyxel Communications, Inc.

26. Collectively, the Accused PD Products and the Accused PSE Products comprise the “Accused Products.” Upon information and belief, the Accused Products are offered for sale and sold throughout the United States, including within this District.

27. Upon information and belief, Defendants have purposefully and voluntarily placed the Accused Products into the stream of commerce with the expectation that these products will be purchased and used by end users in the United States, including end users in this District.

28. Upon information and belief, Defendants provide direct and indirect support concerning the Accused Products to end users, including end users within this District.

COUNT I
INFRINGEMENT OF U.S. PATENT NO. 8,942,107

29. Chrimar alleges and hereby incorporates by reference every allegation made in the foregoing paragraphs of this Complaint as if each were separately set forth herein.

30. In violation of 35 U.S.C. § 271, Defendant has directly infringed and continue to directly infringe, both literally and/or under the doctrine of equivalents, the `107 Patent by making, using, offering for sale, selling, and/or importing the Accused PD Products in the United States, including within this District, that infringe at least claim 103 across claims 6, 16, 56, and 71, and claim 125 across claims 113 and 122 of the `107 Patent without the authority of Chrimar.

31. The identified claims of the `107 Patent are presumed valid.

32. Each of the Accused PD Products is a piece of BaseT Ethernet data terminal equipment. For example, the representative Toshiba IK-WR31A Network Camera is a device that can originate and terminate Ethernet data and Ethernet data transmissions, and is configured to communicate with other devices over a BaseT Ethernet network via Ethernet signals.



<https://objects.eanixter.com/PD518015.PDF>, p. 1.

33. Each of the Accused PD Products has an Ethernet connector comprising first and second pairs of contacts. For example, the representative Toshiba IK-WR31A Network Camera has an RJ-45 Ethernet connector (labelled “Ethernet (LAN) port”), which has four pairs of contacts:

Interface	
Ethernet connectors	10 Base-T/100 Base-TX, RJ45 connector

<https://objects.eanixter.com/PD518015.PDF>, p. 2.

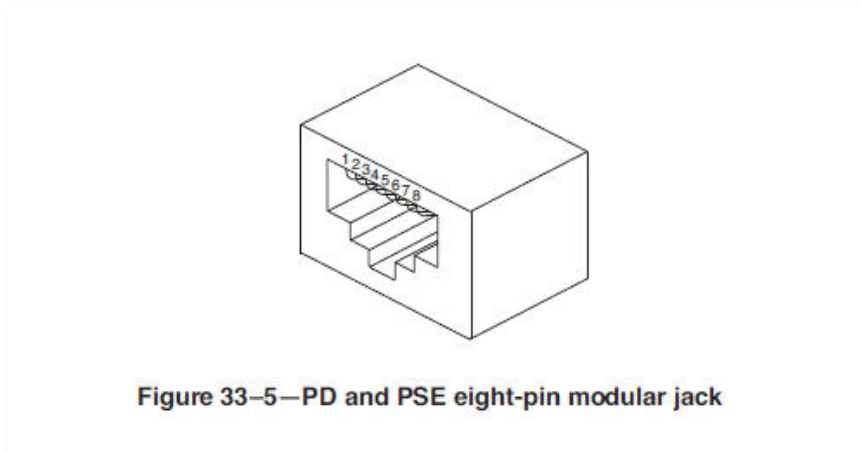

IEEE 802.3af standard, Figure 33-5

34. Each of the Accused PD Products uses an Ethernet connector's first and second pairs of contacts to carry Ethernet communication signals. For example, the pairs of contacts of the Ethernet connector of the Toshiba IK-WR31A Network Camera can carry 10BaseT and 100BaseTX Ethernet communication data signals:

Interface	
Ethernet connectors	10 Base-T/100 Base-TX, RJ45 connector

<https://objects.eanixter.com/PD518015.PDF>, p. 2.

35. Each of the Accused PD Products is a powered-off end device prior to receiving any of its operating power. For example, the Toshiba IK-WR31A Network Camera is a powered-off end device when requesting its operating power or when it is not physically connected to the network.

36. Each of the Accused PD Products has at least one path for the purpose of drawing DC current, the at least one path coupled across at least one of the contacts of the first pair of contacts and at least one of the contacts of the second pair of contacts of its Ethernet connector.

For example, the representative Toshiba IK-WR31A Network Camera claims compliance with the IEEE 802.3af standard:

Power requirements 802.3af PoE, 12V DC \pm 10%

<https://objects.eanixter.com/PD518015.PDF>, p. 2.

37. The IEEE 802.3af standard explains:

33.3.1 PD PI

The PD shall be capable of accepting power on either of two sets of PI conductors. The two conductor sets are named Mode A and Mode B. In each four-wire connection, the two wires associated with a pair are at the same nominal average voltage. Figure 33-5 in conjunction with Table 33-7 illustrates the two power modes.

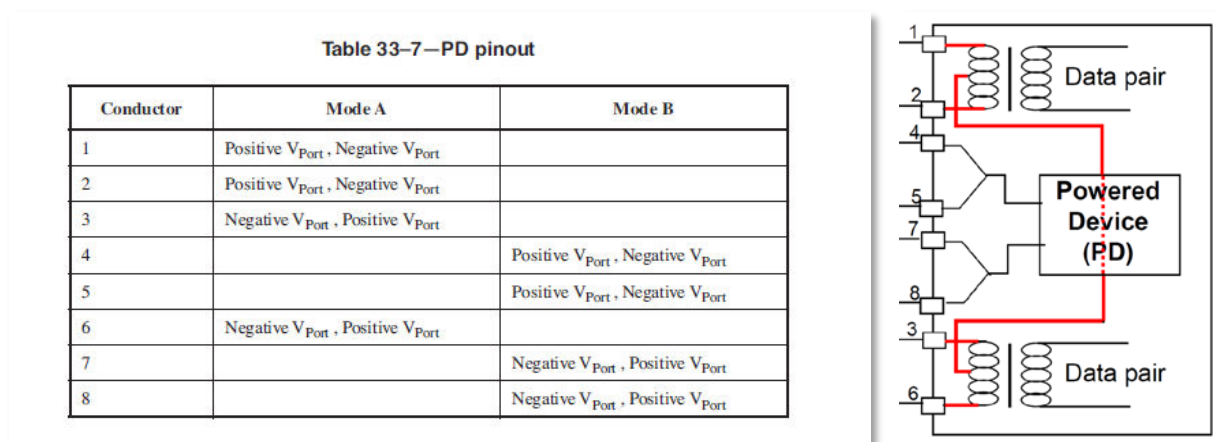

IEEE 802.3af standard, 33.3.1, Table 33-7, and Figure 33-4 (annotated, emphasis added).

38. Each Accused PD Product draws different magnitudes of DC current flow via the at least one path, the different magnitudes of DC current flow to result from at least one condition applied to at least one of the contacts of the first and second pairs of contacts of its Ethernet connector. For example, the representative Toshiba IK-WR31A Network Camera claims compliance with the IEEE 802.3af standard. *See*

<https://objects.eanixter.com/PD518015.PDF>, p. 2. IEEE 802.3af explains:

33.3.3 PD valid and non-valid detection signatures

A PD shall present a valid detection signature at the PI between Positive V_{Port} and Negative V_{Port} of PD Mode A and between Positive V_{Port} and Negative V_{Port} of PD Mode B as defined in 33.3.1 while it is in a state where it will accept power via the PI, but is not powered via the PI.

A PD shall present a non-valid detection signature at the PI between Positive V_{Port} and Negative V_{Port} of PD Mode A and between Positive V_{Port} and Negative V_{Port} of PD Mode B as defined in 33.3.1 while it is in a state where it will not accept power via the PI.

When a PD becomes powered via the PI, it shall present a non-valid detection signature on the set of pairs from which is it not drawing power.

The valid and non-valid detection signature regions are separated by guardbands. The guardbands for the V-I slope are the ranges 12K Ω to 23.75K Ω and 26.25K Ω to 45K Ω . A PD that presents a signature in a guard-band is non-compliant.

V-I slope is the effective resistance calculated from the two voltage/current measurements made during the detection process.

$$V-I \text{ slope} = (V_2 - V_1) / (I_2 - I_1) \quad (33-1)$$

where (V_1, I_1) and (V_2, I_2) are measurements made at the PD PI.

The valid PD detection signature shall have the characteristics of Table 33-8.

IEEE 802.3af standard, 33.3.3

39. Each of the Accused PD Products can convey information about itself (e.g., while powered-off) via magnitudes of the DC current flow. For example, the representative Toshiba IK-WR31A Network Camera claims compliance with the IEEE 802.3af standard. *See* <https://objects.eanixter.com/PD518015.PDF>, p. 2. IEEE 802.3af explains:

The Power Sourcing Equipment (PSE) is located at an endpoint or midspan, separate from and between the MDIs, and provides power to the Powered Device (PD) over the Link Section. The PSE detection protocol distinguishes a compatible PD from non-compatible devices and precludes the application of power and possible damage to non-compatible devices.”

Table 33–8— Valid PD detection signature characteristics, measured at PD input connector

Parameter	Conditions	Minimum	Maximum	Unit
V-I Slope (at any 1V or greater chord within the voltage range conditions)	2.7V to 10.1V	23.75	26.25	K Ω
V offset			1.9	V
I offset			10	μ A
Input capacitance	2.7V to 10.1 V	0.05	0.12	μ F
Input inductance	2.7V to 10.1 V		100	μ H

A non-valid detection signature shall have one or both of the characteristics in Table 33–9

Table 33–9— Non-valid PD detection signature characteristics, measured at PD input connector

Parameter	Conditions	Range of values	Unit
V-I Slope	V < 10.1V	Either greater than 45 or less than 12	K Ω
Input Capacitance	V < 10.1V	Greater than 10	μ F

IEEE 802.3af standard, Abstract, Table 33-8, and Table 33-9

40. Upon information and belief, discovery will show that the at least one path is integrated into each of the Accused PD Products.

41. Each of the Accused PD Products (e.g., while powered-off, i.e., without any of its operating power) can draw different magnitudes of DC current flow via at least one of the contacts of the first and second pairs of contacts of its Ethernet connector. For example, the representative Toshiba IK-WR31A Network Camera claims compliance with the IEEE 802.3af standard. See <https://objects.eanixter.com/PD518015.PDF>, p. 2. The IEEE 802.3af standard prescribes the presentation of valid detection signatures by drawing different magnitudes of DC

current flow in response to at least one electrical connection (e.g. a voltage or current) applied to a contact:

33.3.3 PD valid and non-valid detection signatures

A PD shall present a valid detection signature at the PI between Positive V_{Port} and Negative V_{Port} of PD Mode A and between Positive V_{Port} and Negative V_{Port} of PD Mode B as defined in 33.3.1 while it is in a state where it will accept power via the PI, but is not powered via the PI.

A PD shall present a non-valid detection signature at the PI between Positive V_{Port} and Negative V_{Port} of PD Mode A and between Positive V_{Port} and Negative V_{Port} of PD Mode B as defined in 33.3.1 while it is in a state where it will not accept power via the PI.

When a PD becomes powered via the PI, it shall present a non-valid detection signature on the set of pairs from which is it not drawing power.

The valid and non-valid detection signature regions are separated by guardbands. The guardbands for the V-I slope are the ranges 12K Ω to 23.75K Ω and 26.25K Ω to 45K Ω . A PD that presents a signature in a guardband is non-compliant.

V-I slope is the effective resistance calculated from the two voltage/current measurements made during the detection process.

$$V-I \text{ slope} = (V_2 - V_1) / (I_2 - I_1) \tag{33-1}$$

where (V_1, I_1) and (V_2, I_2) are measurements made at the PD PI.

The valid PD detection signature shall have the characteristics of Table 33-8.

Table 33-8— Valid PD detection signature characteristics, measured at PD input connector

Parameter	Conditions	Minimum	Maximum	Unit
V-I Slope (at any 1V or greater chord within the voltage range conditions)	2.7V to 10.1V	23.75	26.25	K Ω
V offset			1.9	V
I offset			10	μ A
Input capacitance	2.7V to 10.1 V	0.05	0.12	μ F
Input inductance	2.7V to 10.1 V		100	μ H

A non-valid detection signature shall have one or both of the characteristics in Table 33-9

Table 33-9— Non-valid PD detection signature characteristics, measured at PD input connector

Parameter	Conditions	Range of values	Unit
V-I Slope	V < 10.1V	Either greater than 45 or less than 12	K Ω
Input Capacitance	V < 10.1V	Greater than 10	μ F

IEEE 802.3af standard, 33.3.3, Table 33-8, and Table 33-9

42. Upon information and belief, discovery will show that each Accused PD Product has at least one path and the at least one path comprises at least two different impedances.

43. The DC current can comprise a first magnitude of DC current for a first interval followed by a second magnitude of DC current for a second interval, wherein the second magnitude is greater than the first magnitude. For example:

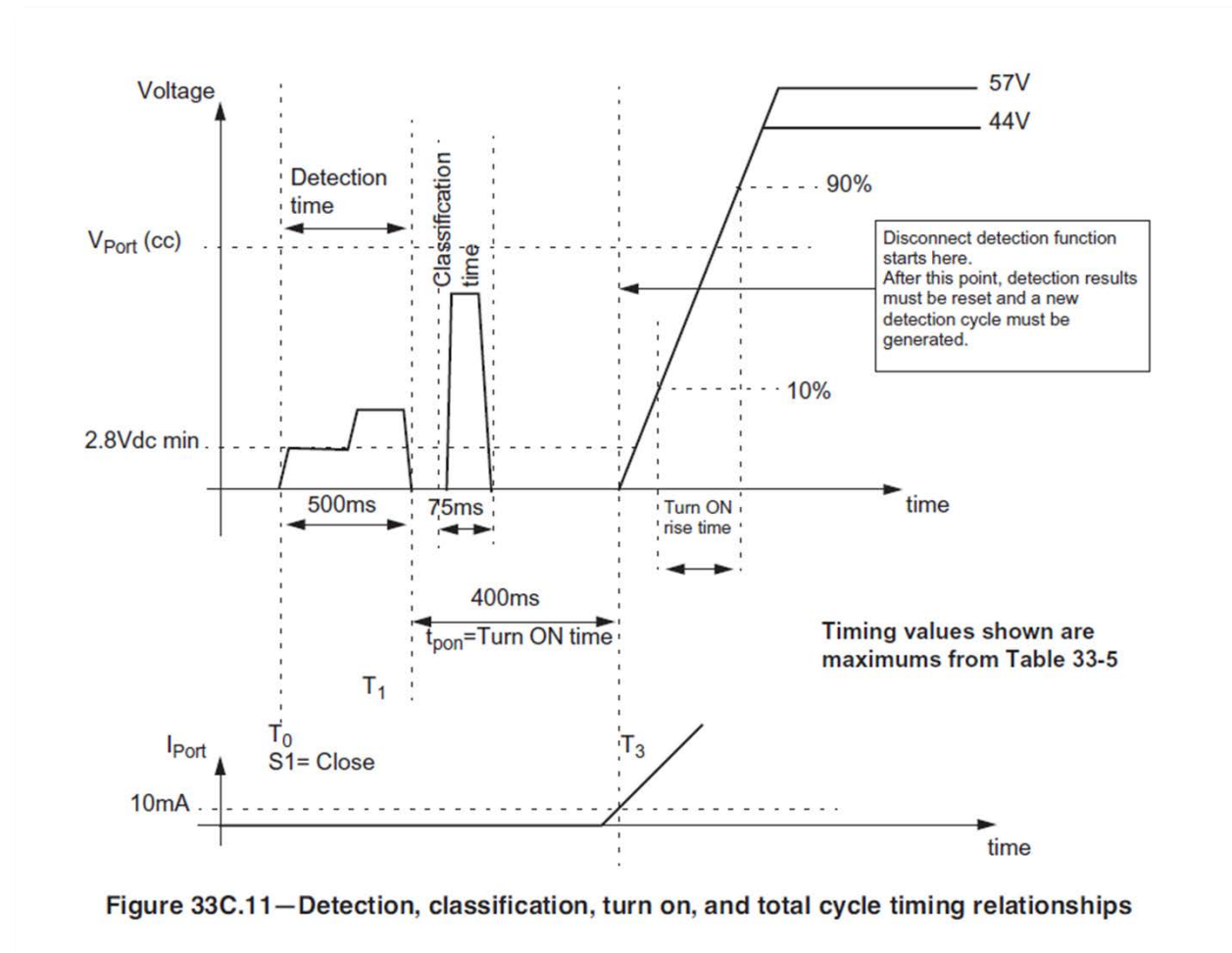

IEEE 802.3af standard, Figure 33C.11

44. The first and second magnitudes of DC current can generally be used, for example, to distinguish a PD like the Accused PD Products from a non-PD or legacy device, and to identify each Accused PD Product's power requirements.

45. Accordingly, Defendant has and continues to directly infringe the `107 Patent, both literally and/or under the doctrine of equivalents, in violation of 35 U.S.C. § 271(a) by making, using, offering for sale, selling, and/or importing into the United States the Accused Products without the authority of Chrimar.

46. Defendant has been on notice of the `107 Patent since at least filing of this Complaint. *See Script Sec. Sols. L.L.C. v. Amazon.com, Inc.*, 170 F. Supp. 3d 928, 937 (E.D. Tex. 2016).

47. In violation of 35 U.S.C. § 271(b), Defendant has indirectly infringed the `107 Patent by inducing its customers to directly infringe the `107 Patent, both literally and/or under the doctrine of equivalents, at least by providing its customers with instructions on using the Accused Products and by making, using, offering for sale, selling, and/or importing devices in the United States the Accused Products without the authority of Chrimar. For example, the representative Toshiba IK-WR31A Network Camera's Quick Start Guide instructs:

Network Deployment

Power over Ethernet (PoE)

- **When using a PoE-enabled switch**

The camera is PoE-compliant, allowing transmission of power and data via single LAN cable. See the following illustration to connect the camera to a PoE switch via LAN cable.

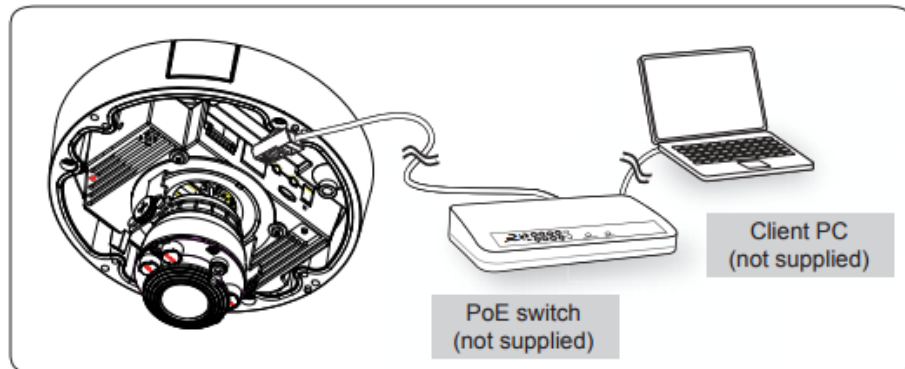

- **When using a non-PoE switch**

Use a PoE power injector (not supplied) to connect between the camera and a non-PoE switch.

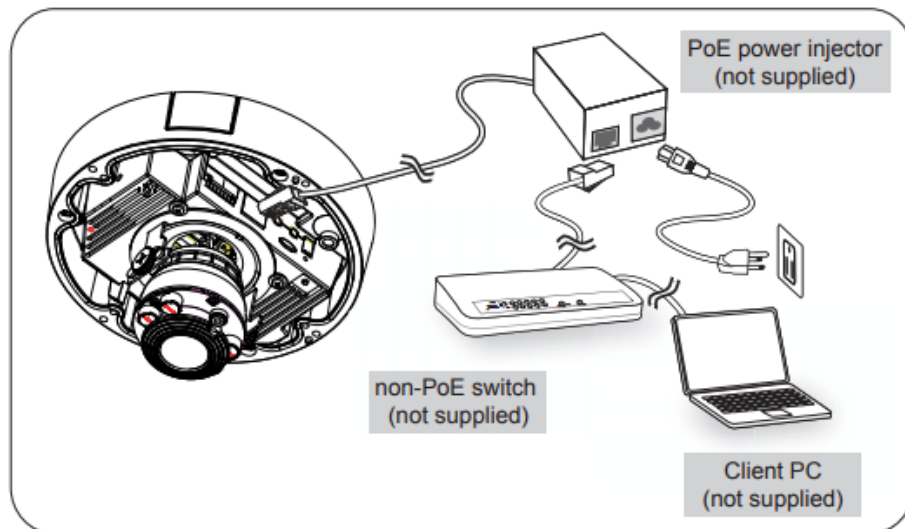

IK-WR31A_QSG.pdf, p. 17.

48. Upon information and belief, and in violation of 35 U.S.C. § 271(b), Defendant has indirectly infringed the `107 Patent by contribution knowing that the Accused Products would be combined with other components to infringe the `107 Patent and that the Accused Products have no substantial non-infringing use.

49. Unless enjoined by this Court, Defendant will continue to infringe the `107 Patent.

50. Because of Defendant's infringing activities, Chrimar has suffered damages and will continue to suffer damages in the future.

COUNT II
INFRINGEMENT OF U.S. PATENT NO. 9,812,825

51. Chrimar alleges and hereby incorporates by reference every allegation made in the foregoing paragraphs of this Complaint as if each were separately set forth herein.

52. The `825 Patent is presumed valid.

53. In violation of 35 U.S.C. § 271, Defendant has directly infringed and continue to directly infringe, both literally and/or under the doctrine of equivalents, the `825 Patent by making, using, offering for sale, selling, and/or importing the Accused PSE Products in the United States, including within this District, that infringe at least claims 5, 13, 15, 16, and 17 of the `825 Patent without the authority of Chrimar. In further violation of 35 U.S.C. § 271, Defendant has directly infringed and continue to directly infringe, both literally and/or under the doctrine of equivalents, the `825 Patent by making, using, offering for sale, selling, and/or importing the Accused PD Products in the United States, including within this District, that infringe at least claims 40, 45, 49, 50, and 64 of the `825 Patent without the authority of Chrimar.

54. The Accused PD Products are powered-off BaseT Ethernet devices are configured to be interrogated for a predetermined response via at least one direct current (DC) signal prior to receiving any of their operating power.

55. For example, each Accused PD Product has pairs of contacts of its Ethernet connector that are used to carry 10BaseT and/or 100BaseTX Ethernet communication signals. Additionally, each Accused PD Product implements Section 33.3.5.1 of the 802.3af standard, or

a similar provision of another standard, which defines that a PD is powered off and shall “turn on” when certain conditions are met. For example, the representative Toshiba IK-WR31A Network Camera datasheet states:

Power requirements	802.3af PoE, 12V DC ± 10%
---------------------------	----------------------------------

<https://objects.eanixter.com/PD518015.PDF>, p. 2.

56. Each Accused PD Product complies or is compatible with the portions of the IEEE 802.3af standard that prescribe the presentation of valid detection signatures by drawing different magnitudes of DC current flow in response to at least one electrical connection (e.g., a voltage or current) applied to contacts of an Ethernet connector described in the below excerpts:

33.3.3 PD valid and non-valid detection signatures

A PD shall present a valid detection signature at the PI between Positive V_{Port} and Negative V_{Port} of PD Mode A and between Positive V_{Port} and Negative V_{Port} of PD Mode B as defined in 33.3.1 while it is in a state where it will accept power via the PI, but is not powered via the PI.

A PD shall present a non-valid detection signature at the PI between Positive V_{Port} and Negative V_{Port} of PD Mode A and between Positive V_{Port} and Negative V_{Port} of PD Mode B as defined in 33.3.1 while it is in a state where it will not accept power via the PI.

When a PD becomes powered via the PI, it shall present a non-valid detection signature on the set of pairs from which is it not drawing power.

The valid and non-valid detection signature regions are separated by guardbands. The guardbands for the V-I slope are the ranges 12K Ω to 23.75K Ω and 26.25K Ω to 45K Ω . A PD that presents a signature in a guardband is non-compliant.

V-I slope is the effective resistance calculated from the two voltage/current measurements made during the detection process.

$$V-I \text{ slope} = (V_2 - V_1) / (I_2 - I_1) \quad (33-1)$$

where (V_1, I_1) and (V_2, I_2) are measurements made at the PD PI.

The valid PD detection signature shall have the characteristics of Table 33-8.

Table 33-8— Valid PD detection signature characteristics, measured at PD input connector

Parameter	Conditions	Minimum	Maximum	Unit
V-I Slope (at any 1V or greater chord within the voltage range conditions)	2.7V to 10.1V	23.75	26.25	KΩ
V offset			1.9	V
I offset			10	μA
Input capacitance	2.7V to 10.1 V	0.05	0.12	μF
Input inductance	2.7V to 10.1 V		100	μH

A non-valid detection signature shall have one or both of the characteristics in Table 33-9

Table 33-9— Non-valid PD detection signature characteristics, measured at PD input connector

Parameter	Conditions	Range of values	Unit
V-I Slope	V < 10.1V	Either greater than 45 or less than 12	KΩ
Input Capacitance	V < 10.1V	Greater than 10	μF

IEEE 802.3af standard, Abstract, Table 33-8, and Table 33-9

57. Each Accused PD Product is a BaseT Ethernet device that comprises an Ethernet jack connector. The Ethernet jack connector comprises first and second pairs of contacts (1,2 & 3,6). Each of the first and second pairs are configured to carry BaseT Ethernet communication signals wherein the first pair of contacts consists of a transmit pair of the Ethernet jack connector and wherein the second pair of contacts consists of the receive pair of the Ethernet jack connector.

58. For example, the representative Toshiba IK-WR31A Network Camera has an RJ-45 Ethernet connector with four pairs of contacts:

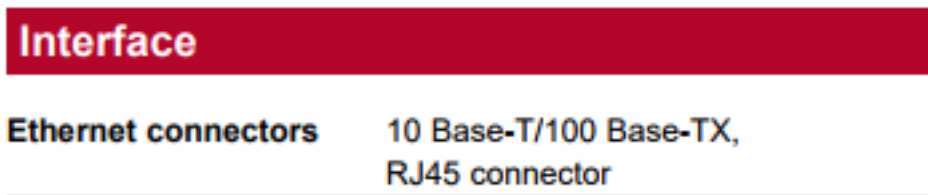

<https://objects.eanixter.com/PD518015.PDF>, p. 2.

59. Each Accused PD Product is a BaseT Ethernet device that comprises at least one path. The at least one path is for the purpose of drawing at least one direct current (DC) signal. The at least one path is coupled across at least one of the contacts of the first pair (1,2) and at least one of the contacts of the second pair (3,6) of the Ethernet jack connector.

60. For example, because each of the Accused PD Products comply with the PoE Standards, each “shall be capable of accepting power on either of two sets of PI conductors (1,2 & 3,6 or 4,5 & 7,8). The two conductor sets are named Mode A and Mode B. In each four-wire connection, the two wires associated with a pair are at the same nominal average voltage. Figure 33–5 in conjunction with Table 33–7 illustrates the two power modes.” IEEE 802.3af standard, p. 49.

Table 33–7—PD pinout

Conductor	Mode A	Mode B
1	Positive V_{Port} , Negative V_{Port}	
2	Positive V_{Port} , Negative V_{Port}	
3	Negative V_{Port} , Positive V_{Port}	
4		Positive V_{Port} , Negative V_{Port}
5		Positive V_{Port} , Negative V_{Port}
6	Negative V_{Port} , Positive V_{Port}	
7		Negative V_{Port} , Positive V_{Port}
8		Negative V_{Port} , Positive V_{Port}

IEEE 802.3af standard, Table 33-7. *See also, e.g.,* 802.3af Standard, p. 30, Figure 33-4 showing examples of PDs (referred to as Powered End Stations with respect to Figure 33-4) having paths coupled across the contacts of the Ethernet connector to be used for detection and classification.

Because each Accused PD Product claims IEEE 802.3af/at compliance or compatibility, each has at least one path coupled across the contacts of the Ethernet connector as shown in the simplified example below.

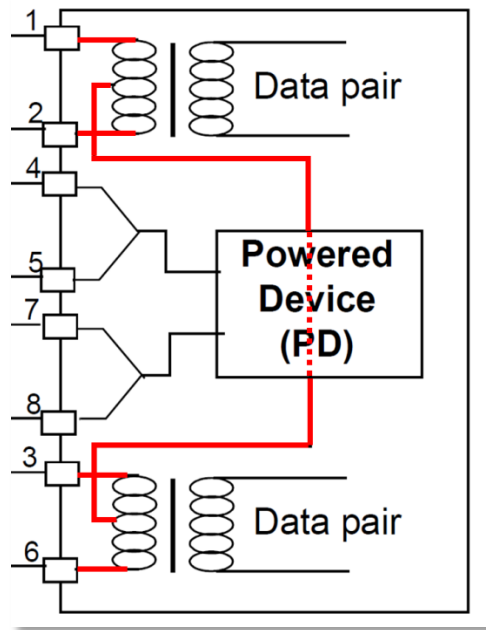

IEEE 802.3af standard, Figure 33-4 (annotated, emphasis added)

61. Each Accused PD Product implements detection and classification protocols requiring at least one path for the purpose of drawing DC current, the at least one path coupled across at least one of the contacts of the first pair of contacts of the Ethernet connector and at least one of the contacts of the second pair of contacts of the Ethernet connector as explained in the 802.3af standard:

33.3.3 PD valid and non-valid detection signatures

A PD shall present a valid detection signature at the PI between Positive V_{Port} and Negative V_{Port} of PD Mode A and between Positive V_{Port} and Negative V_{Port} of PD Mode B as defined in 33.3.1 while it is in a state where it will accept power via the PI, but is not powered via the PI.

A PD shall present a non-valid detection signature at the PI between Positive V_{Port} and Negative V_{Port} of PD Mode A and between Positive V_{Port} and Negative V_{Port} of PD Mode B as defined in 33.3.1 while it is in a state where it will not accept power via the PI.

When a PD becomes powered via the PI, it shall present a non-valid detection signature on the set of pairs from which is it not drawing power.

The valid and non-valid detection signature regions are separated by guardbands. The guardbands for the V-I slope are the ranges 12K Ω to 23.75K Ω and 26.25K Ω to 45K Ω . A PD that presents a signature in a guardband is non-compliant.

V-I slope is the effective resistance calculated from the two voltage/current measurements made during the detection process.

$$\text{V-I slope} = (V_2 - V_1)/(I_2 - I_1) \quad (33-1)$$

where (V_1, I_1) and (V_2, I_2) are measurements made at the PD PI.

The valid PD detection signature shall have the characteristics of Table 33-8.

IEEE 802.3af standard, 33.3.3

62. The Accused PD Products are powered-off BaseT Ethernet devices are configured to receive or return at least one direct current (DC) signal via at least one of the contacts of the first pair and configured to return or receive the at least one direct current (DC) signal via at least one of the contacts of the second pair of the Ethernet connector prior to receiving any of their operating power. The predetermined response is carried by at least two different magnitudes in the flow of the at least one direct current (DC) signal.

63. For example, the below excerpts of the PoE Standards demonstrate that a compliant product, such as the Accused PD Products, will draw different magnitudes of DC current flow in response to at least one electrical connection applied to a contact, as required to comply with the detection and classification protocols.

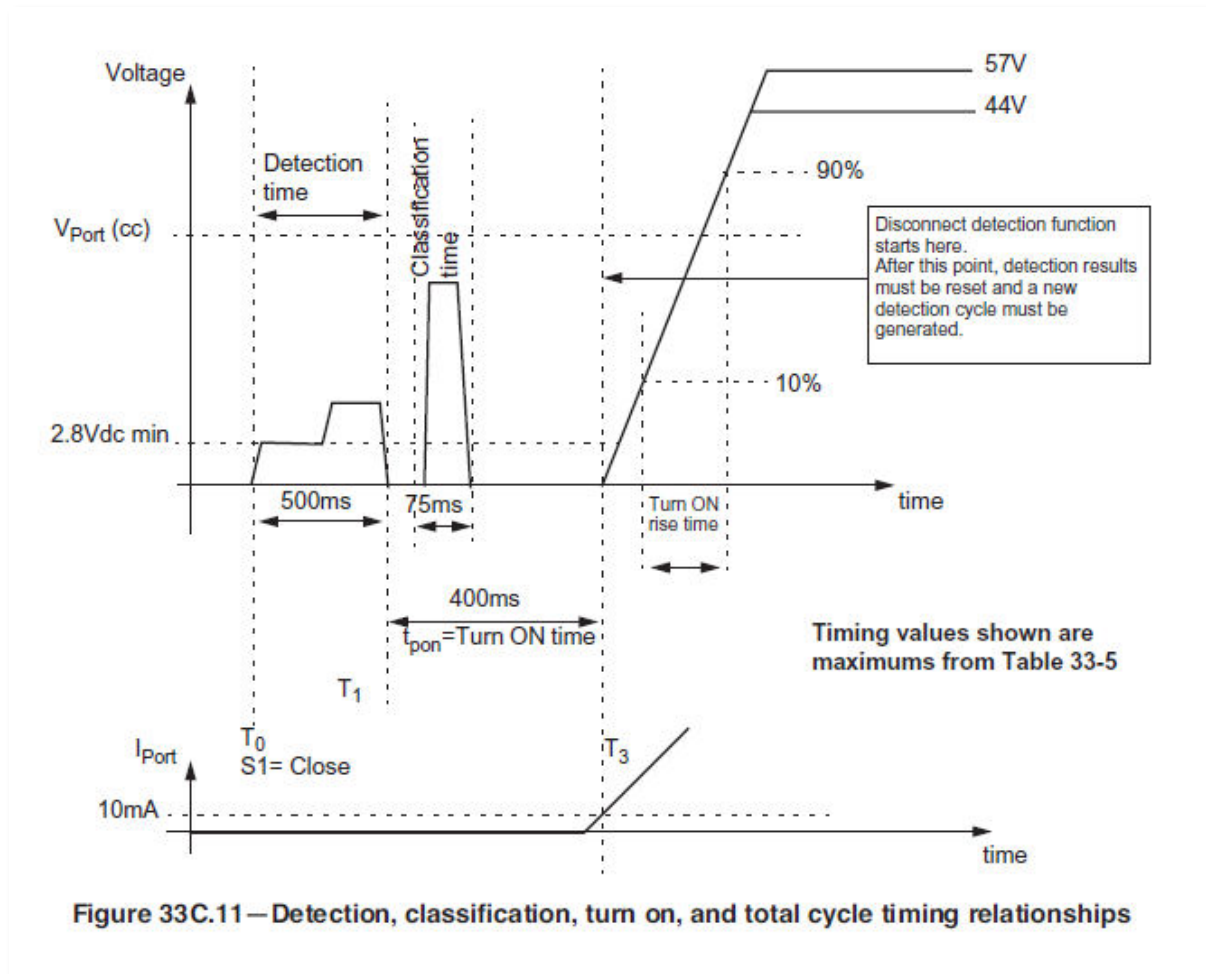

IEEE 802.3af standard, Figure 33C.11 This signature impedance is within the at least one path and distinguishes an Accused PD Product from non-PoE Ethernet devices.

64. Each of the Accused PD Products is a powered-off BaseT Ethernet device wherein the at least one path is physically coupled across at least one of the contacts of the first pair of contacts and at least one of the contacts of the second pair of contacts of the Ethernet jack connector.

65. For example, because each Accused PD Product is 802.3af/at compliant or compatible, each has at least one path coupled across the contacts of the Ethernet connector as shown in the simplified example below.

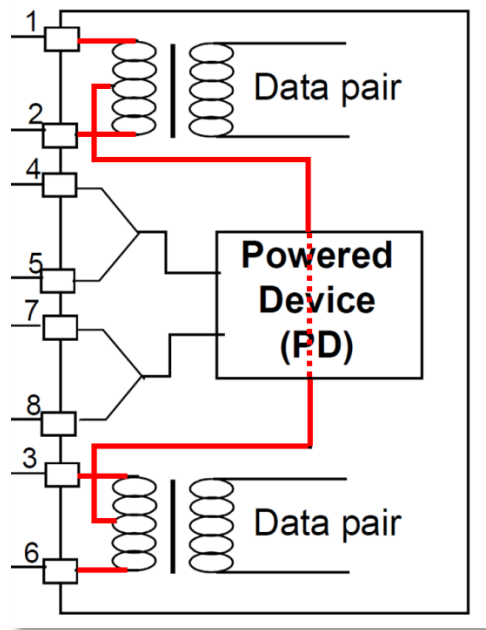

IEEE 802.3af standard, Figure 33-4 (annotated, emphasis added)

66. Each of the Accused PD Products comprises a controller coupled across at least one of the contacts of the first pair of contacts and at least one of the contacts of the second pair of contacts of the Ethernet jack connector.

67. For example, each of the Accused PD Products employs a controller coupled across the recited contacts as described above.

68. Upon information and belief, discovery will show that each of the Accused PD Products has firmware for the controller described above.

69. Each of the Accused PSE Products is a piece of BaseT Ethernet equipment configured to interrogate for predetermined response via at least one direct current (DC) signal.

70. For example, each Accused PSE Product searches the Ethernet data link for PDs as required by 802.3af:

33.2 Power sourcing equipment

PSE, as the name implies, is the equipment that provides the power to a single link section. The PSE's main functions are to search the link section for a PD, optionally classify the PD, supply power to the link section (only if a PD is detected), monitor the power on the link section, and scale power back to the detect level when power is no longer requested or required. An unplugged link section is one instance when power is no longer required.

A PSE is electrically specified at the point of the physical connection to the cabling. Characteristics, such as the losses due to overvoltage protection circuits, or power supply inefficiencies, after the PI connector are not accounted for in this specification.

IEEE 802.3af Standard, 33.2.

71. Each Accused PSE Product has an Ethernet jack connector of the BaseT Ethernet device. The Ethernet jack connector comprising first and second pairs of contacts, each of the first and second pairs configured to carry BaseT Ethernet communication signals wherein the first pair of contacts consists of a transmit pair of the Ethernet jack connector and wherein the second pair of contacts consists of a receive pair of the Ethernet jack connector.

72. For example, the representative EtherWAN EX17908A Ethernet Switch is described as having 8 10/100/1000BASE-TX PoE ports used to connect to a PD or non-PoE end device via a data cable employing modular plugs at each end:

Overview

EtherWAN's EX17908A provides an 8-port switching platform supporting IEEE802.3at Power over Ethernet, high performance switching with features required for enterprise environments.

The EX17908A is equipped with 8 10/100/1000BASE-TX PoE ports. The EX17908A is feature-rich with full wire speed throughput, making the EX17908A Series a powerful network switch.

<https://objects.eanixter.com/PD514286.PDF>, p. 1.

73. Each Accused Ethernet PSE Product has at least one direct current (DC) supply coupled to at least one of the contacts of the first pair of contacts and at least one of the contacts of the second pair of contacts of the Ethernet jack connector.

74. For example, the representative EtherWAN EX17908A Ethernet Switch's datasheet states that the device has "8 10/100/1000BASE-TX PoE" ports.

<https://objects.eanixter.com/PD514286.PDF>, p. 1. The ports are further described as “[t]he IEEE802.3at PoE ports provide up to 30W/port with a total power budget of 240W.” *Id.* A device that is compliant IEEE 802.3at is backwards compatible with IEEE 802.3af. An IEEE 802.3af compliant Accused PSE Product must also include a DC supply in order to perform detection, classification, and control over the provisioning of a PDs’ operationing power:

33.2 Power sourcing equipment

PSE, as the name implies, is the equipment that provides the power to a single link section. The PSE’s main functions are to search the link section for a PD, optionally classify the PD, supply power to the link section (only if a PD is detected), monitor the power on the link section, and scale power back to the detect level when power is no longer requested or required. An unplugged link section is one instance when power is no longer required.

A PSE is electrically specified at the point of the physical connection to the cabling. Characteristics, such as the losses due to overvoltage protection circuits, or power supply inefficiencies, after the PI connector are not accounted for in this specification.

Table 33-5—PSE output PI electrical requirements for all PD classes, unless otherwise specified

Item	Parameter	Symbol	Unit	Min	Max	Additional information
1	Output voltage	V_{Port}	Vdc	44	57	See 33.2.8.1
2	Load regulation		V	44	57	See 33.2.8.2
3	Power feeding ripple and noise:					
	f < 500Hz		V_{pp}		0.5	See 33.2.8.3
	500Hz to 150kHz		V_{pp}		0.2	
	150KHz to 500KHz		V_{pp}		0.15	
500KHz to 1MHz		V_{pp}		0.1		
4	Maximum output current in normal powering mode at PSE min output voltage	I_{Port_max}	mAdc	350		See 33.2.8.4

IEEE 802.3af standard, 33.2, Table 33-5.

75. Each Accused PSE Device is configured to provide or receive at least one direct current (DC) signal via at least one of the contacts of the first pair and configured to receive or provide the at least one direct current (DC) signal via at least one of the contacts of the second

pair of an Ethernet connector, the predetermined response carried by at least two different magnitudes in the flow of the at least one direct current (DC) signal.

76. For example, each of the Accused PSE products use the magnitude in the flow of the current through the loop to interrogate the piece of BaseT Ethernet terminal equipment. For example, the representative EtherWAN EX17908A Ethernet Switch's datasheet explains:

The IEEE802.3at PoE ports provide up to 30W/port with a total power budget of 240W, making the switch truly versatile for connecting with PoE Powered Devices (PD) with different bandwidth and power consumption requirements such as outdoor PTZ dome cameras, wireless access points, and way-side communication devices.

<https://objects.eanixter.com/PD514286.PDF>, p. 1. Devices compliant with IEEE 802.3at, such as the representative product, interrogate the Ethernet data terminal equipment to determine the amount of power (if any) to supply.

77. The Accused PSE Products detect the different magnitudes of DC current flow in response to at least one electrical connection applied to contacts of an Ethernet connector, as required to comply with the detection and classification protocols as illustrated here:

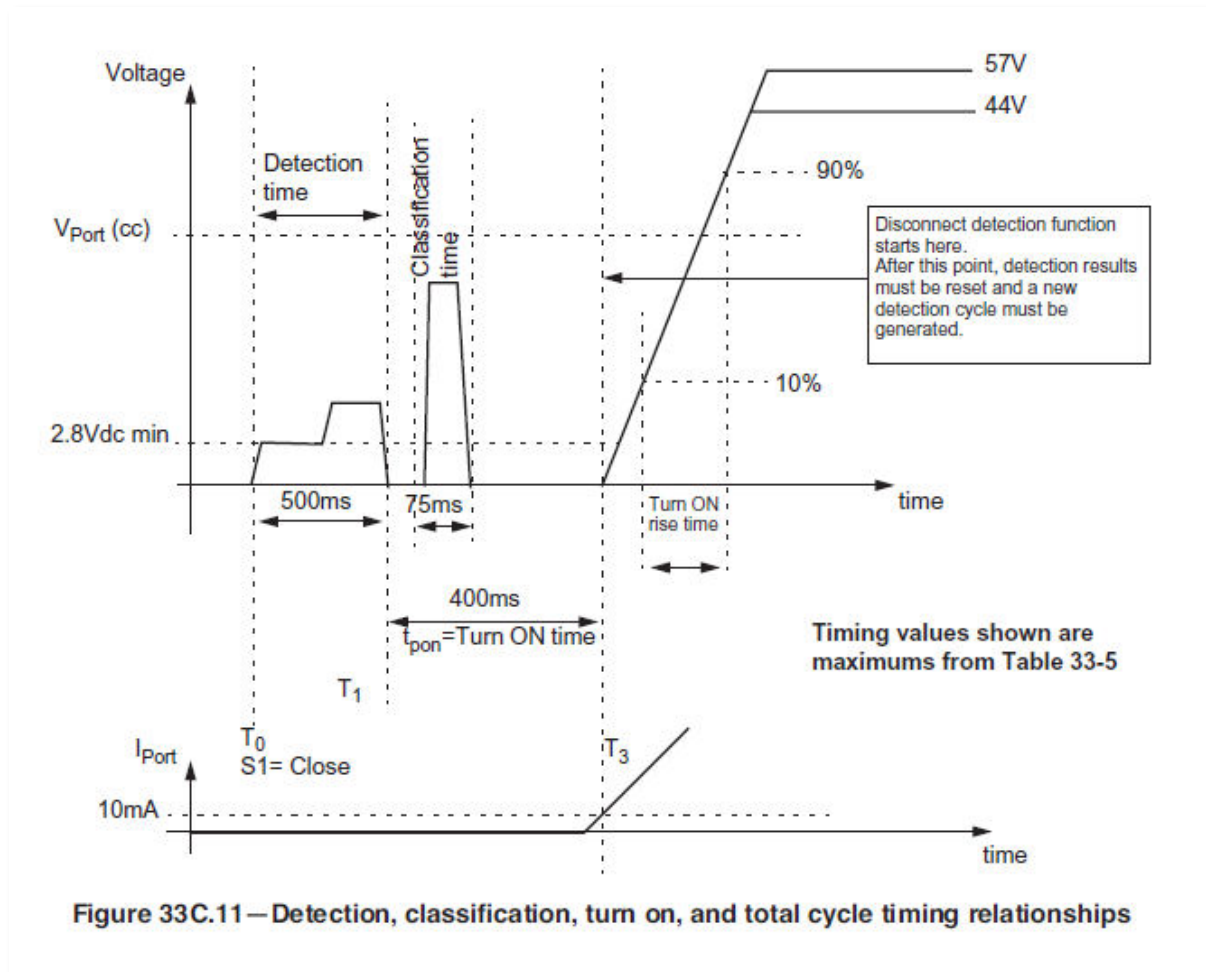

IEEE 802.3af standard, Figure 33C.11 This signature impedance is within the at least one path and distinguishes a PD Ethernet device from a non-PoE (not a PD) Ethernet device.

78. Each of the Accused PSE Products comprise a controller coupled across at least one of the contacts of the first pair of contacts and at least one of the contacts of the second pair of contacts of the Ethernet jack connector.

79. For example, in order for the Accused PSE Products to detect the different magnitudes of DC current flow as described above, the Accused PSE Devices necessarily have a controller coupled to the recited contacts to perform the detection.

80. Upon information and belief, discovery will show that each of the Accused PSE Products has firmware for the controller described in paragraphs 77-78.

81. Accordingly, Defendant has and continues to directly infringe the `825 Patent, both literally and/or under the doctrine of equivalents, in violation of 35 U.S.C. § 271(a) by making, using, offering for sale, selling, and/or importing into the United States the Accused Products without the authority of Chrimar.

82. Defendant has been on notice of the `825 Patent since at least the filing of this Complaint. *See Script Sec. Sols. L.L.C. v. Amazon.com, Inc.*, 170 F. Supp. 3d 928, 937 (E.D. Tex. 2016).

83. In violation of 35 U.S.C. § 271(b), Defendant has indirectly infringed the `825 Patent by inducing its customers to directly infringe the `825 Patent, both literally and/or under the doctrine of equivalents, at least by providing its customers with instructions on using the Accused Products and by making, using, offering for sale, selling, and/or importing devices in the United States the Accused Products without the authority of Chrimar. For example, the representative Toshiba IK-WR31A Network Camera's Quick Start Guide instructs:

Network Deployment

Power over Ethernet (PoE)

- **When using a PoE-enabled switch**

The camera is PoE-compliant, allowing transmission of power and data via single LAN cable. See the following illustration to connect the camera to a PoE switch via LAN cable.

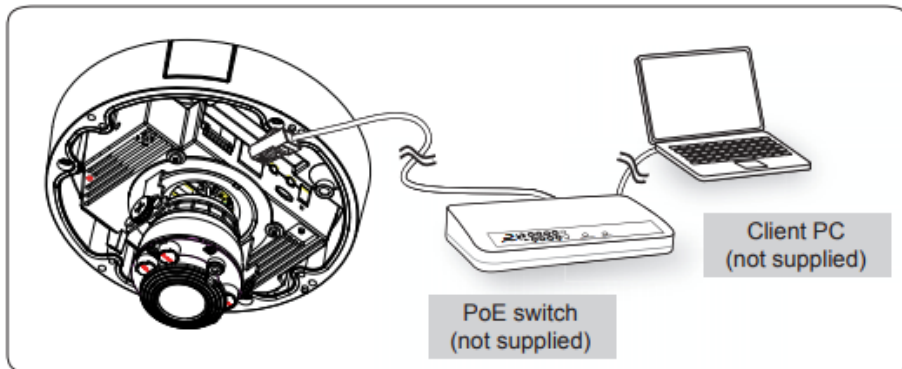

- **When using a non-PoE switch**

Use a PoE power injector (not supplied) to connect between the camera and a non-PoE switch.

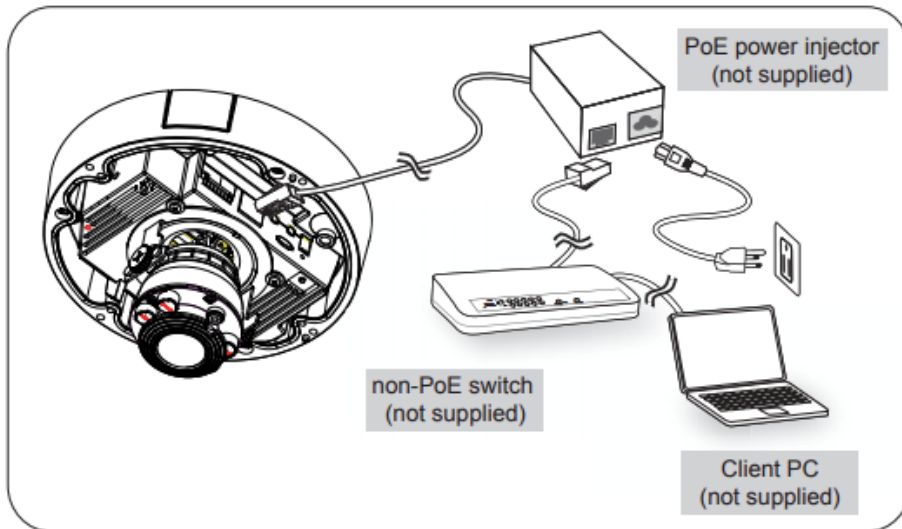

IK-WR31A_QSG.pdf, p. 17.

84. Upon information and belief, and in violation of 35 U.S.C. § 271(b), Defendant has indirectly infringed the '825 Patent by contribution knowing that the Accused Products would be combined with other components to infringe the '825 Patent and that the Accused Products have no substantial non-infringing use.

85. Unless enjoined by this Court, Defendant will continue to infringe the `825 Patent.

86. Because of Defendant's infringing activities, Chrimar has suffered damages and will continue to suffer damages in the future.

COUNT III
INFRINGEMENT OF U.S. PATENT NO. 8,902,760

87. Chrimar alleges and hereby incorporates by reference every allegation made in the foregoing paragraphs of this Complaint as if each were separately set forth herein.

88. In violation of 35 U.S.C. § 271, Defendant has directly infringed and continue to directly infringe, both literally and/or under the doctrine of equivalents, the `760 Patent by making, using, offering for sale, selling, and/or importing the Accused Products in the United States, including within this District, that infringe at least claims 166, 177, and claim 219 across claims 158, 179, and 182 of the `760 Patent without the authority of Chrimar.

89. The identified claims of the `760 Patent are presumed valid.

90. Each of the Accused PD Products is a piece of BaseT Ethernet terminal equipment. For example, the representative Toshiba IK-WR31A Network Camera is a piece of BaseT Ethernet terminal equipment.



<https://objects.eanixter.com/PD518015.PDF>, p. 1.

91. Each of the Accused PSE Products is a piece of central network equipment. For example, the representative EtherWAN EX17908A Ethernet Switch is a piece of central network equipment.

Overview

EtherWAN's EX17908A provides an 8-port switching platform supporting IEEE802.3at Power over Ethernet, high performance switching with features required for enterprise environments.

The EX17908A is equipped with 8 10/100/1000BASE-TX PoE ports. The EX17908A is feature-rich with full wire speed throughput, making the EX17908A Series a powerful network switch.

<https://objects.eanixter.com/PD514286.PDF>, p. 1.

92. The Accused Products comprise a BaseT Ethernet system where Ethernet cabling can physically connect a piece of BaseT Ethernet terminal equipment to a piece of central network equipment. For example, the Toshiba IK-WR31A Network Camera can be physically connected to the representative EtherWAN EX17908A Ethernet Switch with an Ethernet cable.

Interface

Ethernet connectors 10 Base-T/100 Base-TX,
RJ45 connector

<https://objects.eanixter.com/PD518015.PDF>, p. 2.

Overview

EtherWAN's EX17908A provides an 8-port switching platform supporting IEEE802.3at Power over Ethernet, high performance switching with features required for enterprise environments.

The EX17908A is equipped with 8 10/100/1000BASE-TX PoE ports. The EX17908A is feature-rich with full wire speed throughput, making the EX17908A Series a powerful network switch.

<https://objects.eanixter.com/PD514286.PDF>, p. 1.

93. The Ethernet cabling has at least first and second pairs of conductors used to carry BaseT Ethernet communication signals, and the first and second pairs of conductors can physically connect between a piece of BaseT Ethernet terminal equipment and a piece of central network equipment:

Overview

EtherWAN's EX17908A provides an 8-port switching platform supporting IEEE802.3at Power over Ethernet, high performance switching with features required for enterprise environments.

The EX17908A is equipped with 8 10/100/1000BASE-TX PoE ports. The EX17908A is feature-rich with full wire speed throughput, making the EX17908A Series a powerful network switch.

<https://objects.eanixter.com/PD514286.PDF>, p. 1.

94. Each of the Accused PSE Products has at least one DC supply to provide at least one DC condition across at least one of the conductors of the first pair of contacts and at least one of the contacts of the second pairs of contacts of an Ethernet connector. For example, the representative EtherWAN EX17908A Ethernet Switch claims compliance with the IEEE 802.3at standard:

Power

Input

- 100 to 240VAC, 50/60Hz

Power Consumption

- Device: Max. 8.8W (without PoE)
- PoE power budget: 240W Max.

PoE Power Output

- IEEE802.3at: up to 30W/port, 55VDC, 545mA Max.

PoE Technology

- port 2,4,6,8
 - Alternative A, Pins 1/2(+), 3/6(-)
- port 1,3,5,7
 - Alternative B, Pins 7/8(+), 4/5(-)

<https://objects.eanixter.com/PD514286.PDF>, p. 2.

95. A device that is compliant IEEE 802.3at is backwards compatible with IEEE 802.3af. An IEEE 802.3af compliant Accused PSE Product must also include a DC supply in order to perform detection, classification, and control over the provisioning of a PDs operationing power:

33.2 Power sourcing equipment

PSE, as the name implies, is the equipment that provides the power to a single link section. The PSE's main functions are to search the link section for a PD, optionally classify the PD, supply power to the link section (only if a PD is detected), monitor the power on the link section, and scale power back to the detect level when power is no longer requested or required. An unplugged link section is one instance when power is no longer required.

A PSE is electrically specified at the point of the physical connection to the cabling. Characteristics, such as the losses due to overvoltage protection circuits, or power supply inefficiencies, after the PI connector are not accounted for in this specification.

**Table 33-5—PSE output PI electrical requirements for all PD classes,
unless otherwise specified**

Item	Parameter	Symbol	Unit	Min	Max	Additional information
1	Output voltage	V_{Port}	Vdc	44	57	See 33.2.8.1
2	Load regulation		V	44	57	See 33.2.8.2
3	Power feeding ripple and noise:					
	f < 500Hz		V_{pp}		0.5	See 33.2.8.3
	500Hz to 150kHz		V_{pp}		0.2	
	150KHz to 500KHz		V_{pp}		0.15	
500KHz to 1MHz		V_{pp}		0.1		
4	Maximum output current in normal powering mode at PSE min output voltage	I_{Port_max}	mAdc	350		See 33.2.8.4

IEEE 802.3af standard, 33.2, Table 33-5

96. Each of the Accused PD Products has at least one path to change impedance within a loop formed via at least one of the contacts of the first pair of contacts and the at least one of the contacts of the second pair of contacts of the Ethernet connector by changing impedance within the at least one path in response to the at least one DC condition across the at least one path. For example, the representative Toshiba IK-WR31A Network Camera claims compliance with the IEEE 802.3af standard:

Power requirements	802.3af PoE, 12V DC \pm 10%
---------------------------	---

<https://objects.eanixter.com/PD518015.PDF>, p. 2.

97. IEEE 802.3af explains:

33.3.3 PD valid and non-valid detection signatures

A PD shall present a valid detection signature at the PI between Positive V_{Port} and Negative V_{Port} of PD Mode A and between Positive V_{Port} and Negative V_{Port} of PD Mode B as defined in 33.3.1 while it is in a state where it will accept power via the PI, but is not powered via the PI.

A PD shall present a non-valid detection signature at the PI between Positive V_{Port} and Negative V_{Port} of PD Mode A and between Positive V_{Port} and Negative V_{Port} of PD Mode B as defined in 33.3.1 while it is in a state where it will not accept power via the PI.

When a PD becomes powered via the PI, it shall present a non-valid detection signature on the set of pairs from which is it not drawing power.

The valid and non-valid detection signature regions are separated by guardbands. The guardbands for the V-I slope are the ranges 12K Ω to 23.75K Ω and 26.25K Ω to 45K Ω . A PD that presents a signature in a guard-band is non-compliant.

V-I slope is the effective resistance calculated from the two voltage/current measurements made during the detection process.

$$V-I \text{ slope} = (V_2 - V_1)/(I_2 - I_1) \quad (33-1)$$

where (V_1, I_1) and (V_2, I_2) are measurements made at the PD PI.

The valid PD detection signature shall have the characteristics of Table 33-8.

IEEE 802.3af standard, 33.3.3

98. Upon information and belief, discovery will show that the at least one path is integrated into each of the Accused PD Products.

99. Each of the Accused PD Products is a powered-off end device prior to receiving any of its operating power. For example, the representative 1 Toshiba IK-WR31A Network Camera is a powered-off Ethernet end device when requesting power or when it is not connected to the network.

100. Each of the Accused PSE Products can detect at least one impedance condition within the loop with the piece of BaseT Ethernet terminal equipment powered-off. For example, the representative Toshiba IK-WR31A Network Camera claims compliance with the IEEE 802.3af standard. See <https://objects.eanixter.com/PD518015.PDF>, p. 2.

101. IEEE 802.3af explains:

33.2.4 PD detection

In an operational mode, the PSE shall not apply operating power to the PI until the PSE has successfully detected a PD requesting power.

IEEE 802.3af standard, 33.2.4

102. Each of the Accused PSE Products has an integrated DC power source. For example, the representative EtherWAN EX17908A Ethernet Switch's datasheet explains:

Overview

EtherWAN's EX17908A provides an 8-port switching platform supporting IEEE802.3at Power over Ethernet, high performance switching with features required for enterprise environments.

The EX17908A is equipped with 8 10/100/1000BASE-TX PoE ports. The EX17908A is feature-rich with full wire speed throughput, making the EX17908A Series a powerful network switch.

<https://objects.eanixter.com/PD514286.PDF>, p. 1.

103. Each of the Accused PSE Products uses the magnitude in the flow of current through the loop to interrogate the piece of BaseT Ethernet terminal Equipment. For example, the representative EtherWAN EX17908A Ethernet Switch's datasheet explains:

Overview

EtherWAN's EX17908A provides an 8-port switching platform supporting IEEE802.3at Power over Ethernet, high performance switching with features required for enterprise environments.

The EX17908A is equipped with 8 10/100/1000BASE-TX PoE ports. The EX17908A is feature-rich with full wire speed throughput, making the EX17908A Series a powerful network switch.

<https://objects.eanixter.com/PD514286.PDF>, p. 1.

104. Each of the Accused PD Products relates information about itself to at least one impedance condition within the at least one path. For example, each of the Accused PD Products relates its power class to an impedance signature within at least one path during classification and conveys that information via different magnitudes of DC current in response to an electrical condition applied to at least one of the contacts of its Ethernet connector. The Toshiba IK-WR31A Network Camera Network Camera, for example, claims compliance with the

IEEE 802.3af standard. See <https://objects.eanixter.com/PD518015.PDF>, p. 2. IEEE 802.3af explains:

33.3.3 PD valid and non-valid detection signatures

A PD shall present a valid detection signature at the PI between Positive V_{Port} and Negative V_{Port} of PD Mode A and between Positive V_{Port} and Negative V_{Port} of PD Mode B as defined in 33.3.1 while it is in a state where it will accept power via the PI, but is not powered via the PI.

A PD shall present a non-valid detection signature at the PI between Positive V_{Port} and Negative V_{Port} of PD Mode A and between Positive V_{Port} and Negative V_{Port} of PD Mode B as defined in 33.3.1 while it is in a state where it will not accept power via the PI.

When a PD becomes powered via the PI, it shall present a non-valid detection signature on the set of pairs from which is it not drawing power.

The valid and non-valid detection signature regions are separated by guardbands. The guardbands for the V-I slope are the ranges 12K Ω to 23.75K Ω and 26.25K Ω to 45K Ω . A PD that presents a signature in a guardband is non-compliant.

V-I slope is the effective resistance calculated from the two voltage/current measurements made during the detection process.

$$V-I \text{ slope} = (V_2 - V_1) / (I_2 - I_1) \quad (33-1)$$

where (V_1, I_1) and (V_2, I_2) are measurements made at the PD PI.

The valid PD detection signature shall have the characteristics of Table 33-8.

IEEE 802.3af standard, 33.3.3

105. The information can generally be used, for example, to distinguish a piece of Ethernet terminal equipment e.g., a PD like the Accused PD Products from a piece of Ethernet terminal equipment that is not a PD, and/or to identify each Accused PD Product's power requirements or class.

106. Accordingly, Defendant has and continues to directly infringe the '760 Patent, both literally and/or under the doctrine of equivalents, in violation of 35 U.S.C. § 271(a) by making, using, offering for sale, selling, and/or importing into the United States the Accused Products without the authority of Chrimar.

107. Defendant has been on notice of the `760 Patent since at least filing of this Complaint. *See Script Sec. Sols. L.L.C. v. Amazon.com, Inc.*, 170 F. Supp. 3d 928, 937 (E.D. Tex. 2016).

108. In violation of 35 U.S.C. § 271(b), Defendant has indirectly infringed the `760 Patent by inducing its customers to directly infringe the `760 Patent, both literally and/or under the doctrine of equivalents, at least by providing its customers with instructions on using the Accused Products and by making, using, offering for sale, selling, and/or importing devices in the United States the Accused Products without the authority of Chrimar. For example, the representative Toshiba IK-WR31A Network Camera's Installation Guide instructs:

Network Deployment

Power over Ethernet (PoE)

- **When using a PoE-enabled switch**

The camera is PoE-compliant, allowing transmission of power and data via single LAN cable. See the following illustration to connect the camera to a PoE switch via LAN cable.

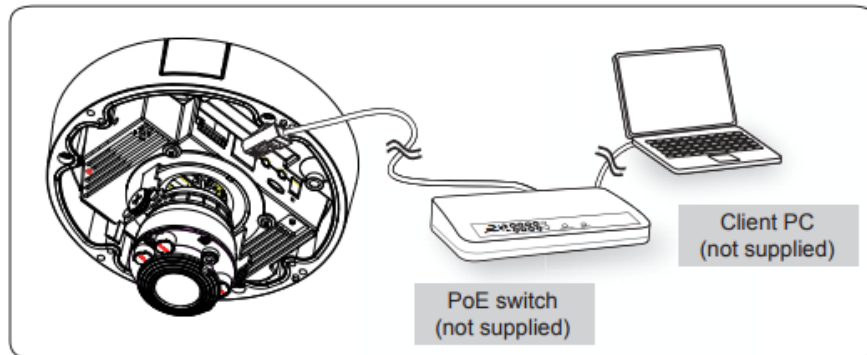

- **When using a non-PoE switch**

Use a PoE power injector (not supplied) to connect between the camera and a non-PoE switch.

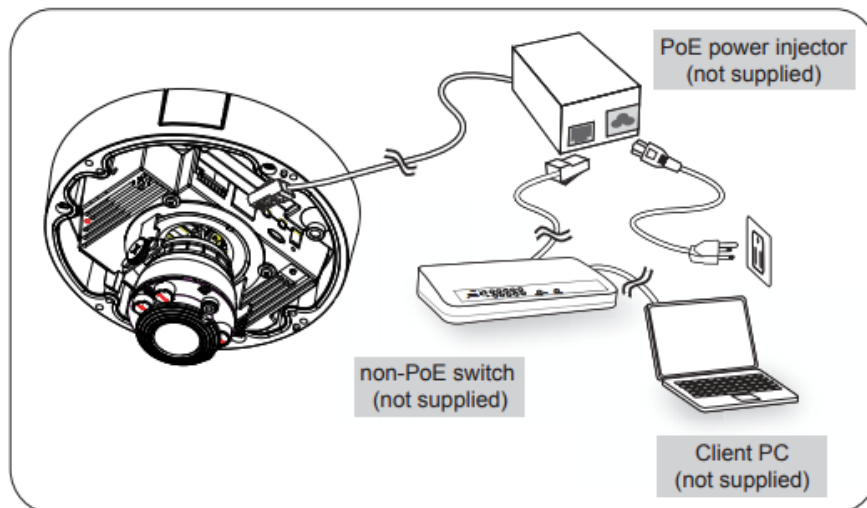

IK-WR31A_QSG.pdf, p. 17.

109. Upon information and belief, and in violation of 35 U.S.C. § 271(b), Defendant has indirectly infringed the `760 Patent by contribution knowing that the Accused Products would be combined with other components to infringe the `760 Patent and that the Accused Products have no substantial non-infringing use.

110. Unless enjoined by this Court, Defendant will continue to infringe the `760 Patent.

111. Because of Defendant's infringing activities, Chrimar has suffered damages and will continue to suffer damages in the future.

COUNT IV
INFRINGEMENT OF U.S. PATENT NO. 9,019,838

112. Chrimar alleges and hereby incorporates by reference every allegation made in the foregoing paragraphs of this Complaint as if each were separately set forth herein.

113. In violation of 35 U.S.C. § 271, Defendant has directly infringed and continues to directly infringe, both literally and/or under the doctrine of equivalents, the `838 Patent by making, using, offering for sale, selling, and/or importing the Accused PSE Products in the United States, including within this District, that infringe at least claims 6 and 76 of the `838 Patent without the authority of Chrimar.

114. The identified claims of the `838 Patent are presumed valid.

115. Each of the Accused PSE Products is a piece of central network equipment. For example, the representative EtherWAN EX17908A Ethernet Switch is a piece of central network equipment.

Overview

EtherWAN's EX17908A provides an 8-port switching platform supporting IEEE802.3at Power over Ethernet, high performance switching with features required for enterprise environments.

The EX17908A is equipped with 8 10/100/1000BASE-TX PoE ports. The EX17908A is feature-rich with full wire speed throughput, making the EX17908A Series a powerful network switch.

<https://objects.eanixter.com/PD514286.PDF>, p. 1.

116. Each of the Accused PSE Products is an Ethernet device. For example, the representative EtherWAN EX17908A Ethernet Switch is a central piece of Ethernet equipment:

Overview

EtherWAN's EX17908A provides an 8-port switching platform supporting IEEE802.3at Power over Ethernet, high performance switching with features required for enterprise environments.

The EX17908A is equipped with 8 10/100/1000BASE-TX PoE ports. The EX17908A is feature-rich with full wire speed throughput, making the EX17908A Series a powerful network switch.

<https://objects.eanixter.com/PD514286.PDF>, p. 1.

117. Each of the Accused PSE Products has at least one Ethernet connector comprising first and second pairs of contacts used to carry BaseT Ethernet communication signals. For example, the representative EtherWAN EX17908A Ethernet Switch has at least one RJ-45 Ethernet connector comprising first and second pairs of contacts and is used to carry 10BaseT, 100BaseTX, and 1000BaseT Ethernet communication signals:

Hardware Specifications

Technology

Standards

- IEEE802.3 10BASE-T
- IEEE802.3u 100BASE-TX/100BASE-FX
- IEEE802.3x Full duplex and flow control
- IEEE802.3ab 1000BASE-TX
- IEEE802.3z 1000BASE-SX/LX
- IEEE802.3af/at Power over Ethernet

Forward and Filtering Rate

- 14,880pps for 10Mbps
- 148,810pps for 100Mbps
- 1,488,100pps for 1000Mbps

Packet Buffer Memory

- 2M bits

Processing Type

- Store-and-Forward
- Half-duplex back-pressure and IEEE802.3x full-duplex flow control

Jumbo Frame

- 9.6K bytes

Address Table Size

- 8192 MAC addresses

Power

Input

- 100 to 240VAC, 50/60Hz

Power Consumption

- Device: Max. 8.8W (without PoE)
- PoE power budget: 240W Max.

PoE Power Output

- IEEE802.3at: up to 30W/port, 55VDC, 545mA Max.

PoE Technology

- port 2,4,6,8
 - Alternative A, Pins 1/2(+), 3/6(-)
 - port 1,3,5,7
 - Alternative B, Pins 7/8(+), 4/5(-)

<https://objects.eanixter.com/PD514286.PDF>, p. 2.

118. Each of the Accused PSE Products is configured to detect different magnitudes of DC current flow via at least one of the contacts of the first and second pairs of contacts of its

Ethernet connector and configured to control application of at least one electrical condition to at least one of the contacts of the first and second pairs of contacts of an Ethernet connector in response to at least one of the magnitudes of the DC current flow. For example, the representative EtherWAN EX17908A Ethernet Switch claims compliance with the IEEE 802.3at standard:

Overview

EtherWAN's EX17908A provides an 8-port switching platform supporting IEEE802.3at Power over Ethernet, high performance switching with features required for enterprise environments.

The EX17908A is equipped with 8 10/100/1000BASE-TX PoE ports. The EX17908A is feature-rich with full wire speed throughput, making the EX17908A Series a powerful network switch.

<https://objects.eanixter.com/PD514286.PDF>, p. 1.

119. A device that is compliant IEEE 802.3at is backwards compatible with IEEE 802.3af. The IEEE 802.3af standard describes detecting different magnitudes of current flow that occur as part of the detection and classification protocols:

33.2.4 PD detection

In an operational mode, the PSE shall not apply operating power to the PI until the PSE has successfully detected a PD requesting power.

33.2.5.1 Detection probe requirements

The detection voltage V_{detect} shall be within the V_{valid} voltage range at the PSE PI as specified in Table 33–2 with a valid PD detection signature connected. The PSE shall make at least two measurements with V_{detect} values that create at least a ΔV_{test} difference as specified in Table 33–2 between the two measurements with a valid PD detection signature connected.

NOTE—Settling time before voltage or current measurement: the voltage or current measurement should be taken after V_{detect} has settled to within 1% of its steady state condition.

The PSE shall control the slew rate of the probing detection voltage when switching between detection voltages to be less than V_{slew} as specified in Table 33–2.

The polarity of V_{detect} shall match the polarity of V_{Port} as defined in 33.2.1.

IEEE 802.3af standard, 33.2.4, 33.2.5.1

120. Each of the Accused PSE Products is configured to provide at least one DC current via at least one of the contacts of the first and second pairs of contacts of its Ethernet connector and configured to detect identifying information within the DC current via the at least one of the contacts of the first and second pairs of contacts of its Ethernet connector. For example, the representative EtherWAN EX17908A Ethernet Switch claims compliance with the IEEE 802.3at standard. See <https://objects.eanixter.com/PD514286.PDF>, p. 1. A device that is IEEE 802.3at compliant is backwards compatible with IEEE 802.3af. The IEEE 802.3af standard explains, for example:

33.2.5 PSE validation circuit

The PSE shall detect the PD by probing via the PSE PI. The Thevenin equivalent of the detection circuit is shown in Figure 33–8. PSE requirements are stated for a Thevenin circuit only; they may be transformed via circuit theory into other circuit parameters in specific implementations.

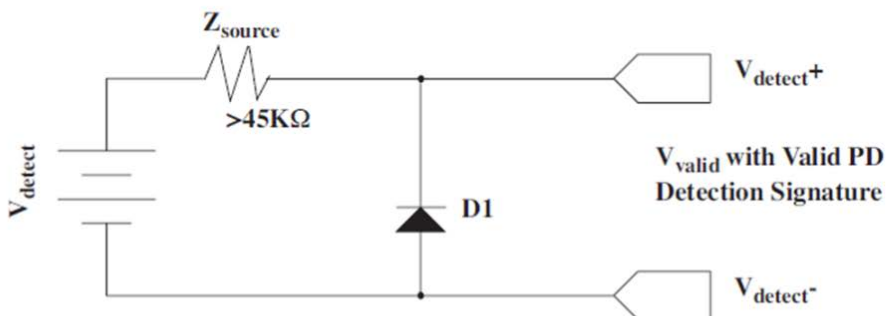

Figure 33–8 – PSE detection source

33.2.7.1 Classification power levels

PDs provide information that allow a PSE to classify their power requirements. The classifications are listed in Table 33–3.

Class 4 is reserved for future use. PDs classified as Class 4 shall be treated as Class 0 for powering purposes.

IEEE 802.3af standard, 33.2.5, Figure 33-8, and 33.2.7.1

121. The detection and classification protocols employ different magnitudes of current flow via specific contacts of an Ethernet connector:

33.2.2 PI pin assignments

A PSE device may provide power via one of two valid four-wire connections. In each four-wire connection, the two conductors associated with a pair each carry the same nominal current in both magnitude and polarity. Figure 33–5, in conjunction with Table 33–1, illustrates the valid alternatives.

Table 33–1 – PSE pinout alternatives

Conductor	Alternative A (MDI-X)	Alternative A (MDI)	Alternative B (All)
1	Negative V_{Port}	Positive V_{Port}	
2	Negative V_{Port}	Positive V_{Port}	
3	Positive V_{Port}	Negative V_{Port}	
4			Positive V_{Port}
5			Positive V_{Port}
6	Positive V_{Port}	Negative V_{Port}	
7			Negative V_{Port}
8			Negative V_{Port}

IEEE 802.3af standard, 33.2.2, Figure 33-1

122. Accordingly, Defendant has and continues to directly infringe the `838 Patent, both literally and/or under the doctrine of equivalents, in violation of 35 U.S.C. § 271(a) by making, using, offering for sale, selling, and/or importing into the United States the Accused Products without the authority of Chrimar.

123. Defendant has been on notice of the `838 Patent since at least filing of this Complaint. *See Script Sec. Sols. L.L.C. v. Amazon.com, Inc.*, 170 F. Supp. 3d 928, 937 (E.D. Tex. 2016).

124. In violation of 35 U.S.C. § 271(b), Defendant has indirectly infringed the `838 Patent by inducing its customers to directly infringe the `838 Patent, both literally and/or under the doctrine of equivalents, at least by providing its customers with instructions on using

the Accused Products and by making, using, offering for sale, selling, and/or importing devices in the United States the Accused Products without the authority of Chrimar. For example:

The IEEE802.3at PoE ports provide up to 30W/port with a total power budget of 240W, making the switch truly versatile for connecting with PoE Powered Devices (PD) with different bandwidth and power consumption requirements such as outdoor PTZ dome cameras, wireless access points, and way-side communication devices.

<https://objects.eanixter.com/PD514286.PDF>, p. 1.

125. Upon information and belief, and in violation of 35 U.S.C. § 271(b), Defendants\ has indirectly infringed the `838 Patent by contribution knowing that the Accused Products would be combined with other components to infringe the `838 Patent and that the Accused Products have no substantial non-infringing use.

126. Unless enjoined by this Court, Defendant will continue to infringe the `838 Patent.

127. Because of Defendant's infringing activities, Chrimar has suffered damages and will continue to suffer damages in the future.

APPLICATION FOR PRELIMINARY AND PERMANENT INJUNCTION

128. Chrimar alleges and hereby incorporates by reference each and every of the allegations made in the foregoing paragraphs of this Complaint as if each were separately set forth herein.

129. As discussed above, Chrimar was the first company to employ DC current within a BaseT network in the early 1990s and has received a number of US patents for this very important technology, and continues to market its products including the EtherLock® II and ELID products. See http://cmstech.com/security_solutions/products/products.html. Chrimar's EtherLock® II product practices certain claims of the `838 Patent, and the installed ELID/NIC-

Stick circuitry practice certain claims of the `107, `760, and `825 Patents. *See also* <http://www.cmspatents.com/>.

130. Upon information and belief, Defendant, unless enjoined, will continue to infringe Chrimar's intellectual property rights in the `107, `825, `760, and `838 Patents as described in this Complaint.

131. These actions entitle Chrimar to a preliminary injunction and, upon hearing, permanent injunction enjoining Defendant and its officers, agents, servants, employees, users, and attorneys, and all those persons in active concert or in participation with them from:

- (i) Making, using, offering to sell, or selling any product that infringes the `107, `825, `760, and `838 Patents, including the Accused Products and all other similar infringing products; and
- (ii) Otherwise infringing any rights of Chrimar.

132. For these actions, there is no adequate remedy at law. The Patents-in-Suit cover the core technology of Chrimar's and Defendant's businesses. Defendant's efficient infringement gives them an unfair advantage in the marketplace by allowing Defendant to make infringing alternatives available to the marketplace. In view of this, the injury to Chrimar greatly outweighs any injury to Defendants that the requested injunction may cause, and the balance of hardships tips strongly in favor of Chrimar.

133. Further, Chrimar is substantially likely to prevail on the merits of these claims. For example, in *Chrimar Systems, Inc., et al., v. Alcatel-Lucent Enterprise, USA, Inc.*, Alcatel-Lucent stipulated to infringement of certain claims of the `107, `760, and `838 Patents and the jury rejected Alcatel-Lucent's validity challenge to the `107, `760, and `838 Patent's claims asserted in that case. Civil Action No. 6:15-cv-163-JDL, Dkt No. 349 (Verdict Form, Oct. 10, 2016), Dkt No. 423 (Final Judgment, February 2, 2017) (E.D. Tex.).

134. Finally, the injunction will not disserve the public interest. Here, the public interest favors entry of a permanent injunction because the detrimental effect of inhibiting innovation, coupled with the public's general interest in the judicial protection of property rights in inventive technology, outweighs any interest the public has in purchasing cheaper infringing products.

135. Therefore, Chrimar is entitled to preliminary and permanent injunctive relief against Defendant.

ADDITIONAL ALLEGATIONS

136. Chrimar has complied with 35 U.S.C. § 287.

NOTICE OF REQUIREMENT OF LITIGATION HOLD

137. Defendants are hereby notified they are legally obligated to locate, preserve, and maintain all records, notes, drawings, documents, data, communications, materials, electronic recordings, audio/video/photographic recordings, and digital files, including edited and unedited or "raw" source material, and other information and tangible things that Defendants know, or reasonably should know, may be relevant to actual or potential claims, counterclaims, defenses, and/or damages by any party or potential party in this lawsuit, whether created or residing in hard copy form or in the form of electronically stored information (hereafter collectively referred to as "Potential Evidence").

138. As used above, the phrase "electronically stored information" includes without limitation: computer files (and file fragments), e-mail (both sent and received, whether internally or externally), information concerning e-mail (including but not limited to logs of e-mail history and usage, header information, and deleted but recoverable emails), text files (including drafts, revisions, and active or deleted word processing documents), instant messages, audio recordings

and files, video footage and files, audio files, photographic footage and files, spreadsheets, databases, calendars, telephone logs, contact manager information, internet usage files, and all other information created, received, or maintained on any and all electronic and/or digital forms, sources and media, including, without limitation, any and all hard disks, removable media, peripheral computer or electronic storage devices, laptop computers, mobile phones, personal data assistant devices, Blackberry devices, iPhones, video cameras and still cameras, and any and all other locations where electronic data is stored. These sources may also include any personal electronic, digital, and storage devices of any and all of Defendant's agents, resellers, or employees if Defendant's electronically stored information resides there.

139. Defendant is hereby further notified and forewarned that any alteration, destruction, negligent loss, or unavailability, by act or omission, of any Potential Evidence may result in damages or a legal presumption by the Court and/or jury that the Potential Evidence is not favorable to Defendant's claims and/or defenses. To avoid such a result, Defendant's preservation duties include, but are not limited to, the requirement that Defendant immediately notify its agents and employees to halt and/or supervise the autodelete functions of Defendant's electronic systems and refrain from deleting Potential Evidence, either manually or through a policy of periodic deletion.

JURY DEMAND

Pursuant to Rule 38 of the Federal Rules of Civil Procedure, Chrimar demands a trial by jury on all issues triable as such.

PRAYER FOR RELIEF

Chrimar requests that this Court find in its favor and against Defendant, and that this Court grant Chrimar the following relief:

- A. An adjudication that Defendant has infringed the `107, `825, `760, and `838 Patents;
- B. An award of damages to be paid by Defendant adequate to compensate Chrimar for Defendant's past infringement of the Patents-in-Suit and any continuing or future infringement through the date such judgment is entered (but in no event less than a reasonable royalty in accordance with 35 U.S.C. § 284), including interest, costs, expenses and an accounting of all infringing acts including, but not limited to, those acts not presented at trial;
- C. A preliminary and permanent injunction enjoining Defendant and its officers, agents, servants, employees, users, attorneys, and all those persons in active concert or participation with Defendant from the acts described in this Complaint;
- D. Alternatively, an order requiring Defendant to pay an ongoing royalty in an amount to be determined for any continued infringement after the date judgment is entered;
- E. An award of pre-judgment and post-judgment interest to the full extent allowed under the law, as well as their costs;
- F. A declaration that this case is exceptional under 35 U.S.C. § 285, and an award of Chrimar's reasonable attorneys' fees;
- G. An award to Chrimar of such further relief at law or in equity as the Court deems just and proper.

Dated: June 4, 2018

Respectfully submitted,

/s/ Gary R. Sorden

Gary R. Sorden

Texas Bar No. 24066124

gary.sorden@klemchuk.com

Mark D. Perantie

Texas Bar No. 24053647

mark.perantie@klemchuk.com

Timothy J.H. Craddock

Texas Bar No. 24082868

tim.craddock@klemchuk.com

KLEMCHUK LLP

8150 N. Central Expressway

10th Floor

Dallas, Texas 75206

Tel: 214-367-6000

Fax: 214-367-6001

ATTORNEY FOR PLAINTIFFS

CHRIMAR SYSTEMS, INC. D/B/A CMS

TECHNOLOGIES AND CHRIMAR HOLDING

COMPANY, LLC