

**IN THE UNITED STATES DISTRICT COURT
FOR THE DISTRICT OF DELAWARE**

**SUPER INTERCONNECT
TECHNOLOGIES LLC,**

Plaintiff,

v.

MOTOROLA MOBILITY LLC,

Defendant.

§
§ **JURY TRIAL DEMANDED**
§
§
§ **CIVIL ACTION NO. _____**
§
§
§
§
§

PLAINTIFF’S ORIGINAL COMPLAINT FOR PATENT INFRINGEMENT

Plaintiff Super Interconnect Technologies LLC (“Super Interconnect”) files this Original Complaint against Motorola Mobility LLC (“Motorola”) for infringement of U.S. Patent No. 7,627,044 (“the ’044 patent”), U.S. Patent No. 6,463,092 (“the ’092 patent”), and U.S. Patent No. 7,158,593 (“the ’593 patent”).

THE PARTIES

1. Super Interconnect Technologies LLC is a Texas limited liability company, located at 1701 Directors Blvd., Suite 300, Austin, Texas 78744.

2. Motorola Mobility LLC is a limited liability company formed under the laws of the State of Delaware that has its principal place of business located at 222 West Merchandise Mart Plaza, Chicago, Illinois 60654. Motorola may be served with process through its registered agent, The Corporation Trust Company, Corporation Trust Center, 1209 Orange Street, Wilmington, Delaware 19801. Motorola does business in the State of Delaware.

JURISDICTION AND VENUE

3. This action arises under the patent laws of the United States, namely 35 U.S.C. §§ 271, 281, and 284-285, among others.

4. This Court has subject matter jurisdiction pursuant to 28 U.S.C. §§ 1331 and 1338(a).

5. Venue is proper in this judicial district under 28 U.S.C. § 1400(b) because Motorola was formed under the laws of the State of Delaware and, therefore, resides in this District.

6. Motorola is subject to this Court's specific and general personal jurisdiction because Motorola was formed under the laws of the State of Delaware. Additionally, Motorola is subject to personal jurisdiction pursuant to due process due at least to its substantial business in this State, including: (A) at least part of its infringing activities alleged herein; and (B) regularly doing or soliciting business, engaging in other persistent conduct, and/or deriving substantial revenue from goods sold and services provided to Delaware residents. Motorola has conducted and regularly conducts business within the United States and this District. Motorola has purposefully availed itself of the privileges of conducting business in the United States, and more specifically in Delaware and this District. Motorola has sought protection and benefit from the laws of the State of Delaware by forming under the laws of Delaware and placing infringing products into the stream of commerce through an established distribution channel with the awareness and/or intent that they will be purchased by consumers in this District.

7. On information and belief, Motorola has significant ties to, and presence in, this District, making venue in this judicial district both proper and convenient for this action.

COUNT I

(INFRINGEMENT OF U.S. PATENT NO. 7,627,044)

8. Super Interconnect incorporates paragraphs 1 through 7 herein by reference.

9. Super Interconnect is the assignee of the '044 patent, entitled "Clock-Edge Modulated Serial Link with DC-Balance Control," with ownership of all substantial rights in the '044 patent, including the right to exclude others and to enforce, sue, and recover damages

for past and future infringement. A true and correct copy of the '044 patent is attached as Exhibit A.

10. The '044 patent is valid, enforceable, and was duly issued in full compliance with Title 35 of the United States Code. The '044 patent issued from U.S. Patent Application No. 11/264,303.

11. To the extent any marking or notice was required by 35 U.S.C. § 287, Super Interconnect and all predecessors-in-interest to the '044 patent have complied with the requirements of that statute by providing actual or constructive notice to Motorola of its alleged infringement.

12. Motorola has and continues to directly and/or indirectly infringe (by inducing infringement) one or more claims of the '044 patent in this judicial district and elsewhere in the United States, including at least claims 1, 2, 8, 9, 10, 11, 12, 13, 14, 15 and 19, by, among other things, making, having made, using, offering for sale, selling, and/or importing electronic devices with Universal Flash Storage (UFS) that incorporate the fundamental technologies covered by the '044 patent. These products are referred to as the "'044 Accused Products." Examples of the '044 Accused Products include, but are not limited to, the Motorola Moto Z and Motorola Moto Z Force smartphones.

13. For example, the Motorola Moto Z directly infringes claim 1 of the '044 patent, as shown in the below paragraphs.

14. An example Motorola Moto Z is shown in the image below.



<https://www.motorola.com/us/products/moto-z>

15. The Moto Z has storage that includes a 64GB Universal Flash Storage (UFS) as shown in the image below.

Memory (RAM) 4GB LPDDR4 ⁵
Storage (ROM) 64GB UFS, ⁵ microSD Card support (up to 2TB) ⁵

<https://www.motorola.com/us/products/moto-z>

16. The images below show that the Moto Z's UFS storage uses the MIPI M-PHY protocol for physical layer communication between the UFS host and the UFS device.

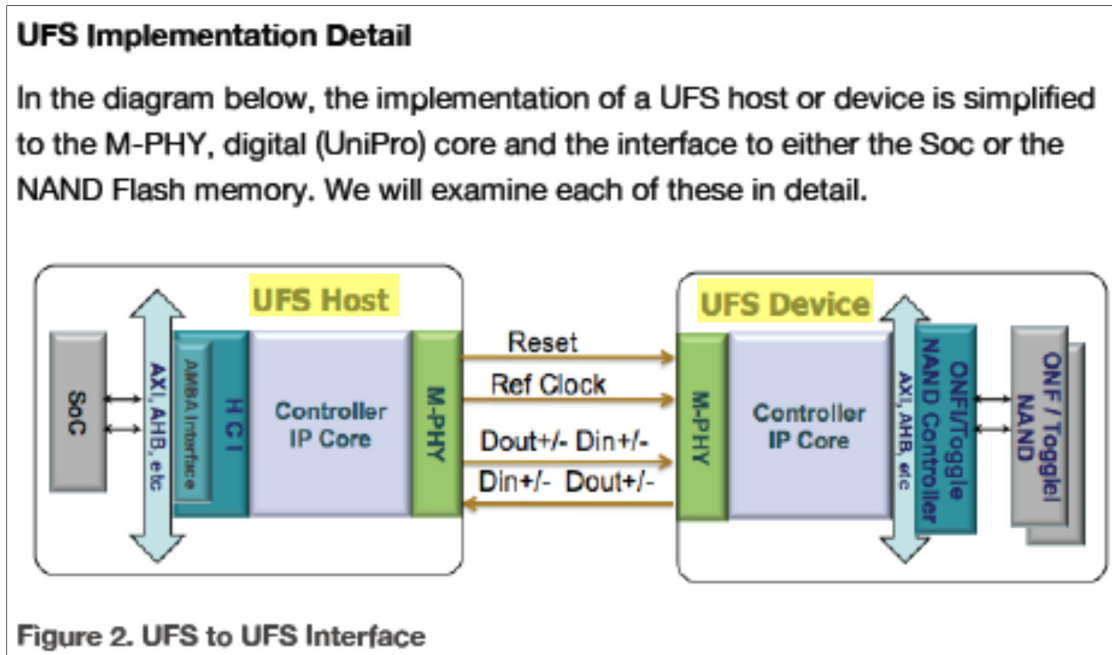

Arasan Chip Systems Inc. White Paper, “Universal Flash Storage: Mobilize Your Data” at 6 (Oct. 2012).

M-PHY I/O

MIPI defines two types of M-PHY, type 1 and type 2. The UFS specification calls out type 1. M-PHY Type 1 uses NRZ signaling for HS and PWM signaling for LS, while type 2 uses NRZ signaling for both HS and LS.

UFS utilizes two speed modes, high-speed and low-speed. Low speed mode In Gear 1 is used upon power up or reset, then a transition occurs to high-speed gears for data transmission. The low speed gears and high-speed gears are listed here for your reference. UFS v1.1 has been ratified and supports HS Gear 2 running approximately @ 3Gbps per lane. The UFS spec also supports up to 4 lanes for higher throughput.

Id.

17. UFS hosts and devices, which are included in the '044 Accused Products, contain signal transmitters. These signal transmitters drive a DC-balanced differential signal for a communications channel. This signal is comprised of a pair of data signals: a positive (true) data signal and a negative (complement) data signal. These transmitters multiplex a pulse-width modulated clock signal, a data signal, and control signals to apply them to the communications channel.

18. The '044 Accused Products thus include each and every limitation of claim 1 of the '044 patent; accordingly, they literally infringe this claim. Motorola directly infringes the '044 patent by making, using, offering to sell, selling, and/or importing the '044 Accused Products. Motorola is thereby liable for direct infringement.

19. During discovery and development of its infringement contentions, Plaintiff may provide additional theories under which Motorola infringes the '044 patent besides the example provided above, including for the same product and using the same components identified above, and nothing in the example above is meant to limit the infringement allegations of Plaintiff or limit the interpretations of the claims or their terms.

20. At a minimum, Motorola has known that the '044 Accused Products infringe the '044 patent at least as early as the service date of this Original Complaint.

21. Upon information and belief, since at least the above-mentioned date when Motorola was on notice of its infringement, Motorola has actively induced, under U.S.C. § 271(b), third-party manufacturers, distributors, importers and/or consumers that purchase or sell the '044 Accused Products that include all of the limitations of one or more claims of the '044 patent to directly infringe one or more claims of the '044 patent by making, having made, using, offering for sale, selling, and/or importing the '044 Accused Products. Since at least the notice provided on the above-mentioned date, Motorola does so with knowledge, or with willful blindness of the fact, that the induced acts constitute infringement of the '044 patent. Upon information and belief, Motorola intends to cause, and has taken affirmative steps to induce, infringement by these third-party manufacturers, distributors, importers, and/or consumers by, *inter alia*, creating advertisements that promote the infringing use of the '044 Accused Products, creating established distribution channels for the '044 Accused Products into and within the United States,

manufacturing the '044 Accused Products in conformity with U.S. laws and regulations, distributing or making available instructions or manuals for these products to purchasers and prospective buyers, and/or providing technical support, replacement parts, or services for these products to these purchasers in the United States. For example, Motorola advertises, and provides support for, the Moto Z on its own website at the following web address: <https://www.motorola.com/us/products/moto-z>.

22. Super Interconnect has been damaged as a result of Motorola's infringing conduct described in this Count. Motorola is, thus, liable to Super Interconnect in an amount that adequately compensates Super Interconnect for Motorola's infringement, which, by law, cannot be less than a reasonable royalty, together with interest and costs as fixed by this Court under 35 U.S.C. § 284.

COUNT II
(INFRINGEMENT OF U.S. PATENT NO. 6,463,092)

23. Super Interconnect incorporates paragraphs 1 through 22 herein by reference.

24. Super Interconnect is the assignee of the '092 patent, entitled "System and Method for Sending and Receiving Data Signals Over A Clock Signal Line," with ownership of all substantial rights in the '092 patent, including the right to exclude others and to enforce, sue, and recover damages for past and future infringement. A true and correct copy of the '092 patent is attached as Exhibit B.

25. The '092 patent is valid, enforceable, and was duly issued in full compliance with Title 35 of the United States Code. The '092 patent issued from U.S. Patent Application No. 09/393,235.

26. To the extent any marking or notice was required by 35 U.S.C. § 287, Super Interconnect and all predecessors-in-interest to the '092 patent have complied with the

requirements of that statute by providing actual or constructive notice to Motorola of its alleged infringement.

27. Motorola has and continues to directly and/or indirectly infringe (by inducing infringement) one or more claims of the '092 patent in this judicial district and elsewhere in the United States, including at least claims 1, 2, 5, 10, and 11 by, among other things, making, having made, using, offering for sale, selling, and/or importing electronic devices with Universal Flash Storage (UFS) that incorporate the fundamental technologies covered by the '092 patent. These products are referred to as the "'092 Accused Products." Examples of the '092 Accused Products include, but are not limited to, the Motorola Moto Z and Motorola Moto Z Force smartphones.

28. For example, the Motorola Moto Z directly infringes claim 1 of the '092 patent, as shown below.

29. An example Motorola Moto Z is shown in the image below.



<https://www.motorola.com/us/products/moto-z>

30. The Moto Z has storage that includes a 64GB Universal Flash Storage (UFS) as shown in the image below.

<p>Memory (RAM) 4GB LPDDR4⁵</p> <p>Storage (ROM) 64GB UFS,⁵ microSD Card support (up to 2TB)⁵</p>
--

<https://www.motorola.com/us/products/moto-z>

31. The images below show that the Moto Z’s UFS storage uses the MIPI M-PHY protocol for physical layer communication between the UFS host and the UFS device.

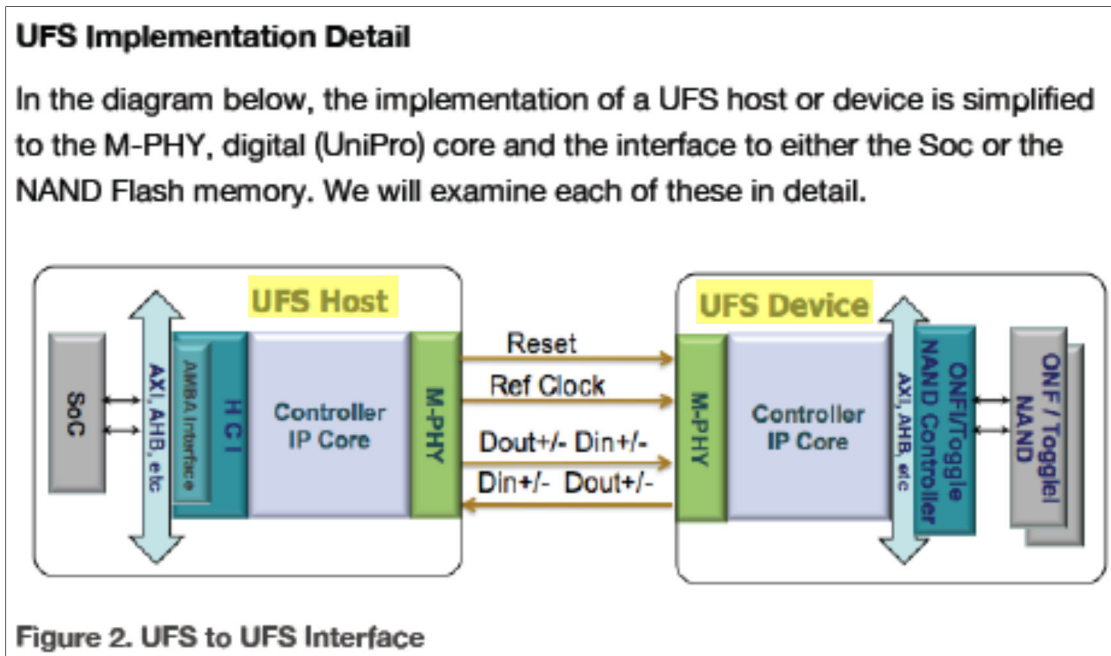

Arasan Chip Systems Inc. White Paper, “Universal Flash Storage: Mobilize Your Data” at 6 (Oct. 2012).

M-PHY I/O

MIPI defines two types of M-PHY, type 1 and type 2. The UFS specification calls out type 1. M-PHY Type 1 uses NRZ signaling for HS and PWM signaling for LS, while type 2 uses NRZ signaling for both HS and LS.

UFS utilizes two speed modes, high-speed and low-speed. Low speed mode In Gear 1 is used upon power up or reset, then a transition occurs to high-speed gears for data transmission. The low speed gears and high-speed gears are listed here for your reference. UFS v1.1 has been ratified and supports HS Gear 2 running approximately @ 3Gbps per lane. The UFS spec also supports up to 4 lanes for higher throughput.

Id.

32. UFS hosts and devices, which are included in the '092 Accused Products, multiplex clock and data signals for transmission over a single communications channel. This clock signal is modulated based on the data to be transmitted before being combined with the output data stream.

33. The '092 Accused Products thus include each and every limitation of claim 1 of the '092 patent; accordingly, they literally infringe this claim. Motorola directly infringes the '092 patent by making, using, offering to sell, selling, and/or importing the '092 Accused Products. Motorola is thereby liable for direct infringement.

34. During discovery and development of its infringement contentions, Plaintiff may provide additional theories under which Motorola infringes the '092 patent besides the example provided above, including for the same product and using the same components identified above, and nothing in the example above is meant to limit the infringement allegations of Plaintiff or limit the interpretations of the claims or their terms.

35. At a minimum, Motorola has known that the '092 Accused Products infringe the '092 patent at least as early as the service date of this Original Complaint.

36. Upon information and belief, since at least the above-mentioned date when Motorola was on notice of its infringement, Motorola has actively induced, under U.S.C. § 271(b), third-party manufacturers, distributors, importers and/or consumers that purchase or sell the '092 Accused Products that include all of the limitations of one or more claims of the '092 patent to directly infringe one or more claims of the '092 patent by making, having made, using, offering for sale, selling, and/or importing the '092 Accused Products. Since at least the notice provided on the above-mentioned date, Motorola does so with knowledge, or with willful blindness of the fact, that the induced acts constitute infringement of the '092 patent. Upon information and belief, Motorola intends to cause, and has taken affirmative steps to induce, infringement by these third-party manufacturers, distributors, importers, and/or consumers by, *inter alia*, creating advertisements that promote the infringing use of the '092 Accused Products, creating established distribution channels for the '092 Accused Products into and within the United States, manufacturing the '092 Accused Products in conformity with U.S. laws and regulations, distributing or making available instructions or manuals for these products to purchasers and prospective buyers, and/or providing technical support, replacement parts, or services for these products to these purchasers in the United States. For example, Motorola advertises, and provides support for, the Moto Z on its own website at the following web address: <https://www.motorola.com/us/products/moto-z>.

37. Super Interconnect has been damaged as a result of Motorola's infringing conduct described in this Count. Motorola is, thus, liable to Super Interconnect in an amount that adequately compensates Super Interconnect for Motorola's infringement, which, by law, cannot be less than a reasonable royalty, together with interest and costs as fixed by this Court under 35 U.S.C. § 284.

COUNT III
(INFRINGEMENT OF U.S. PATENT NO. 7,158,593)

38. Super Interconnect incorporates paragraphs 1 through 37 herein by reference.

39. Super Interconnect is the assignee of the '593 patent, entitled "Combining a Clock Signal and a Data Signal," with ownership of all substantial rights in the '593 patent, including the right to exclude others and to enforce, sue, and recover damages for past and future infringement. A true and correct copy of the '593 patent is attached as Exhibit C.

40. The '593 patent is valid, enforceable, and was duly issued in full compliance with Title 35 of the United States Code. The '593 patent issued from U.S. Patent Application No. 10/099,533.

41. To the extent any marking or notice was required by 35 U.S.C. § 287, Super Interconnect and all predecessors-in-interest to the '593 patent have complied with the requirements of that statute by providing actual or constructive notice to Motorola of its alleged infringement.

42. Motorola has and continues to directly and/or indirectly infringe (by inducing infringement) one or more claims of the '593 patent in this judicial district and elsewhere in the United States, including at least claims 34 and 35, by, among other things, making, having made, using, offering for sale, selling, and/or importing electronic devices with Universal Flash Storage (UFS) that incorporate the fundamental technologies covered by the '593 patent. These products are referred to as the "'593 Accused Products." Examples of the '593 Accused Products include, but are not limited to, the Motorola Moto Z and Motorola Moto Z Force smartphones.

43. The Motorola Moto Z directly infringes claim 34 of the '593 patent, as shown in the below paragraphs.

44. An example Motorola Moto Z is shown in the image below.



<https://www.motorola.com/us/products/moto-z>

45. The Moto Z has storage that includes a 64GB Universal Flash Storage (UFS) as shown in the image below.

Memory (RAM) 4GB LPDDR4 ⁵
Storage (ROM) 64GB UFS, ⁵ microSD Card support (up to 2TB) ⁵

<https://www.motorola.com/us/products/moto-z>

46. The images below show that the Moto Z's UFS storage uses the MIPI M-PHY protocol for physical layer communication between the UFS host and the UFS device.

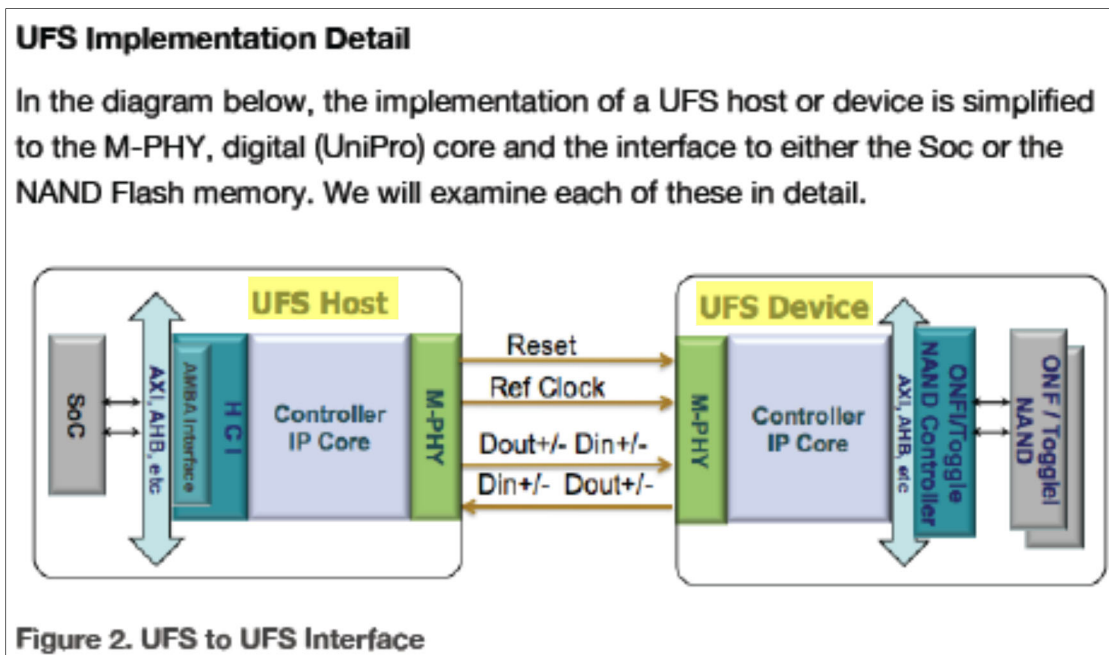

Arasan Chip Systems Inc. White Paper, “Universal Flash Storage: Mobilize Your Data” at 6 (Oct. 2012).

M-PHY I/O

MIPI defines two types of M-PHY, type 1 and type 2. The UFS specification calls out type 1. M-PHY Type 1 uses NRZ signaling for HS and PWM signaling for LS, while type 2 uses NRZ signaling for both HS and LS.

UFS utilizes two speed modes, high-speed and low-speed. Low speed mode In Gear 1 is used upon power up or reset, then a transition occurs to high-speed gears for data transmission. The low speed gears and high-speed gears are listed here for your reference. UFS v1.1 has been ratified and supports HS Gear 2 running approximately @ 3Gbps per lane. The UFS spec also supports up to 4 lanes for higher throughput.

Id.

47. UFS hosts and devices, which are included in the '593 Accused Products, contain signal transmitters. These transmitters encode the data to be transmitted and further multiplex a pulse-width modulated clock signal, an encoded data signal, and control signals to apply them to the communications channel. This encoding scheme shifts an energy spectrum of the combined clock and encoded data signal away from an effective loop bandwidth of a clock recovery block.

48. The '593 Accused Products thus include each and every limitation of claim 34 of the '593 patent; accordingly, they literally infringe this claim. Motorola directly infringes the '593 patent by making, using, offering to sell, selling, and/or importing the '593 Accused Products. Motorola is thereby liable for direct infringement.

49. During discovery and development of its infringement contentions, Plaintiff may provide additional theories under which Motorola infringes the '593 patent besides the example provided above, including for the same product and using the same components identified above, and nothing in the example above is meant to limit the infringement allegations of Plaintiff or limit the interpretations of the claims or their terms.

50. At a minimum, Motorola has known that the '593 Accused Products infringe the '593 patent at least as early as the service date of this Original Complaint.

51. Upon information and belief, since at least the above-mentioned date when Motorola was on notice of its infringement, Motorola has actively induced, under U.S.C. § 271(b), third-party manufacturers, distributors, importers and/or consumers that purchase or sell the '593 Accused Products that include all of the limitations of one or more claims of the '593 patent to directly infringe one or more claims of the '593 patent by making, having made, using, offering for sale, selling, and/or importing the '593 Accused Products. Since at least the notice provided on the above-mentioned date, Motorola does so with knowledge, or with willful blindness of the fact, that the induced acts constitute infringement of the '593 patent. Upon information and belief, Motorola intends to cause, and has taken affirmative steps to induce, infringement by these third-party manufacturers, distributors, importers, and/or consumers by, *inter alia*, creating advertisements that promote the infringing use of the '593 Accused Products, creating established distribution channels for the '593 Accused Products into and within the United States,

manufacturing the '593 Accused Products in conformity with U.S. laws and regulations, distributing or making available instructions or manuals for these products to purchasers and prospective buyers, and/or providing technical support, replacement parts, or services for these products to these purchasers in the United States. For example, Motorola advertises, and provides support for, the Moto Z on its own website at the following web address: <https://www.motorola.com/us/products/moto-z>.

52. Super Interconnect has been damaged as a result of Motorola's infringing conduct described in this Count. Motorola is, thus, liable to Super Interconnect in an amount that adequately compensates Super Interconnect for Motorola's infringement, which, by law, cannot be less than a reasonable royalty, together with interest and costs as fixed by this Court under 35 U.S.C. § 284.

JURY DEMAND

Super Interconnect hereby requests a trial by jury pursuant to Rule 38 of the Federal Rules of Civil Procedure.

PRAYER FOR RELIEF

Super Interconnect requests that the Court find in its favor and against Motorola, and that the Court grant Motorola the following relief:

- a. Judgment that one or more claims of the '044, '092, and '593 patents have been infringed, either literally and/or under the doctrine of equivalents, by Motorola and/or by others whose infringement has been induced by Motorola;
- b. Judgment that Motorola account for and pay to Super Interconnect all damages to and costs incurred by Super Interconnect because of Motorola's infringing activities and other conduct complained of herein;
- c. Judgment that Motorola account for and pay to Super Interconnect a reasonable, ongoing, post-judgment royalty because of Motorola's infringing activities and other conduct complained of herein;
- d. Judgment that Motorola's conduct warrants that the Court award treble

damages pursuant to 35 U.S.C. § 284;

- e. Judgement that Super Interconnect be granted pre-judgment and post-judgment interest on the damages caused by Motorola's infringing activities and other conduct complained of herein;
- f. Judgment and an order finding this to be an exceptional case and requiring Motorola to pay the costs of this action (including all disbursements) and attorneys' fees as provided by 35 U.S.C. § 285; and
- g. That Super Interconnect be granted such other and further relief as the Court may deem just and proper under the circumstances.

Dated: November 2, 2018

Respectfully submitted,

Of Counsel:

FARNAN LLP

Jeffrey R. Bragalone
T. William Kennedy Jr.
Brian P. Herrmann
Bragalone Conroy PC
2200 Ross Avenue
Suite 4500W
Dallas, TX 75201
Tel: (214) 785-6670
Fax: (214) 785-6680
jbragalone@bcpc-law.com
bkennedy@bcpc-law.com
bherrmann@bcpc-law.com

/s/ Michael J. Farnan
Brian E. Farnan (Bar No. 4089)
Michael J. Farnan (Bar No. 5165)
919 N. Market St., 12th Floor
Wilmington, DE 19801
Telephone: (302) 777-0300
Facsimile: (302) 777-0301
bfarnan@farnanlaw.com
mfarnan@farnanlaw.com

Attorneys for Plaintiff