

**IN THE UNITED STATES DISTRICT COURT
FOR THE EASTERN DISTRICT OF TEXAS
MARSHALL DIVISION**

**SUPER INTERCONNECT
TECHNOLOGIES LLC,**

Plaintiff,

v.

GOOGLE LLC,

Defendant.

§
§
§
§
§
§
§
§
§
§

JURY TRIAL DEMANDED

CIVIL ACTION NO. 2:18cv463

PLAINTIFF’S ORIGINAL COMPLAINT FOR PATENT INFRINGEMENT

Plaintiff Super Interconnect Technologies LLC (“Super Interconnect”) files this Original Complaint against Google LLC (“Google”) for infringement of U.S. Patent No. 7,627,044 (“the ’044 patent”), U.S. Patent No. 6,463,092 (“the ’092 patent”), and U.S. Patent No. 7,158,593 (“the ’593 patent”).

THE PARTIES

1. Super Interconnect Technologies LLC is a Texas limited liability company, located at 1701 Directors Blvd., Suite 300, Austin, Texas 78744.

2. On information and belief, Google LLC is a wholly-owned subsidiary of Alphabet, Inc. On information and belief, Google LLC is a limited liability company formed under the laws of the State of Delaware that has its principal place of business located at located at 1600 Amphitheatre Parkway, Mountain View, CA 94043. Google may be served with process through its registered agent, The Corporation Service Company, 251 Little Falls Drive, Wilmington, Delaware 19808. Google does business in the State of Texas and in this District.

JURISDICTION AND VENUE

3. This action arises under the patent laws of the United States, namely 35 U.S.C. §§ 271, 281, and 284-285, among others.

4. This Court has subject matter jurisdiction pursuant to 28 U.S.C. §§ 1331 and 1338(a).

5. Venue is proper in this judicial district under 28 U.S.C. § 1400(b) because Google has committed acts of infringement in the District and has a regular and established place of business in this District. On information and belief, multiple ISPs host Google Global Cache servers in this District, which cache Google's products and deliver them to residents of this District. These Google Global Cache servers cache content that includes video advertising, apps, and digital content from the Google Play store, among other things. Google generates revenue by providing these services to residents of this District. Both the server itself and the place of the Google Global Cache server, independently and together, constitute a "physical place" and a "regular and established place of business" of Google. The Federal Circuit very recently denied mandamus to Google where it challenged this Court's ruling that venue was proper over it under 28 U.S.C. § 1400(b). See *In re Google LLC*, No. 2018-152, 2018 WL 5536478 (Fed. Cir. Oct. 29, 2018).

6. Google is subject to personal jurisdiction pursuant to due process due at least to its substantial business in this State, including: (A) at least part of its infringing activities alleged herein; and (B) regularly doing or soliciting business, engaging in other persistent conduct, and/or deriving substantial revenue from goods sold and services provided to Texas residents. Google has conducted and regularly conducts business within the United States and this District. Google has purposefully availed itself of the privileges of conducting business in the United States, and more

specifically in Texas and this District. Google has sought protection and benefit from the laws of the State of Texas by placing infringing products into the stream of commerce through an established distribution channel with the awareness and/or intent that they will be purchased by consumers in this District.

7. On information and belief, Google has significant ties to, and presence in, this District, making venue in this judicial district both proper and convenient for this action.

COUNT I
(INFRINGEMENT OF U.S. PATENT NO. 7,627,044)

8. Super Interconnect incorporates paragraphs 1 through 7 herein by reference.

9. Super Interconnect is the assignee of the '044 patent, entitled "Clock-Edge Modulated Serial Link with DC-Balance Control," with ownership of all substantial rights in the '044 patent, including the right to exclude others and to enforce, sue, and recover damages for past and future infringement. A true and correct copy of the '044 patent is attached as Exhibit A.

10. The '044 patent is valid, enforceable, and was duly issued in full compliance with Title 35 of the United States Code. The '044 patent issued from U.S. Patent Application No. 11/264,303.

11. To the extent any marking or notice was required by 35 U.S.C. § 287, Super Interconnect and all predecessors-in-interest to the '044 patent have complied with the requirements of that statute by providing actual or constructive notice to Google of its alleged infringement.

12. Google has and continues to directly and/or indirectly infringe (by inducing infringement and/or contributing to infringement) one or more claims of the '044 patent in this judicial district and elsewhere in the United States, including at least claims 1, 2, 8, 9, 10, 11, 12, 13, 14, 15 and 19, by, among other things, making, having made, using, offering for sale, selling,

and/or importing electronic devices with Universal Flash Storage (UFS) that incorporate the fundamental technologies covered by the '044 patent. These products are referred to as the "'044 Accused Products.'" Examples of the '044 Accused Products include, but are not limited to, the Google Pixel and Google Pixel XL smartphones.

13. For example, the Google Pixel directly infringes claim 1 of the '044 patent, as shown in the below paragraphs.

14. An example of the Google Pixel is shown in the image below.

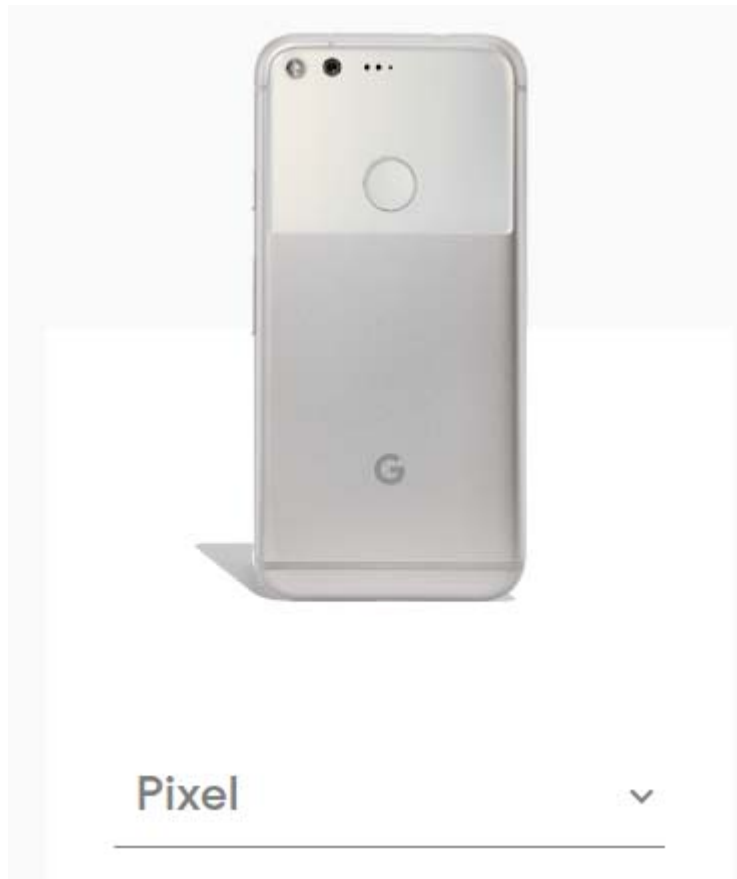

https://store.google.com/us/product/pixel_compare

15. Google incorporates UFS 2.0 storage in its Pixel family of products, as shown in the image below.

What makes the Pixel phones interesting, to me, is the relative lack of technical compromise. They have a fast processor. A fast camera (with improved and quicker HDR+). Fast storage (UFS 2.0). A fast fingerprint scanner. Fast software (they really are blazing-quick). Fast charging. Fast updates (seamless updates). A fast GPU (for VR). There is little about these phones you can point to and say Google cheated out on. And isn't that what so many of us have been demanding for years? A Google phone that could be positioned against the iPhone as legitimate competition (even if the iPhone does have its advantages - and disadvantages).

<http://www.androidpolice.com/2016/10/04/google-pixel-and-pixel-xl-hands-on-google-takes-on-the-iphone-by-becoming-the-iphone/>

16. The images below show that the Google Pixel's UFS storage uses the MIPI M-PHY protocol for physical layer communication between the UFS host and the UFS device.

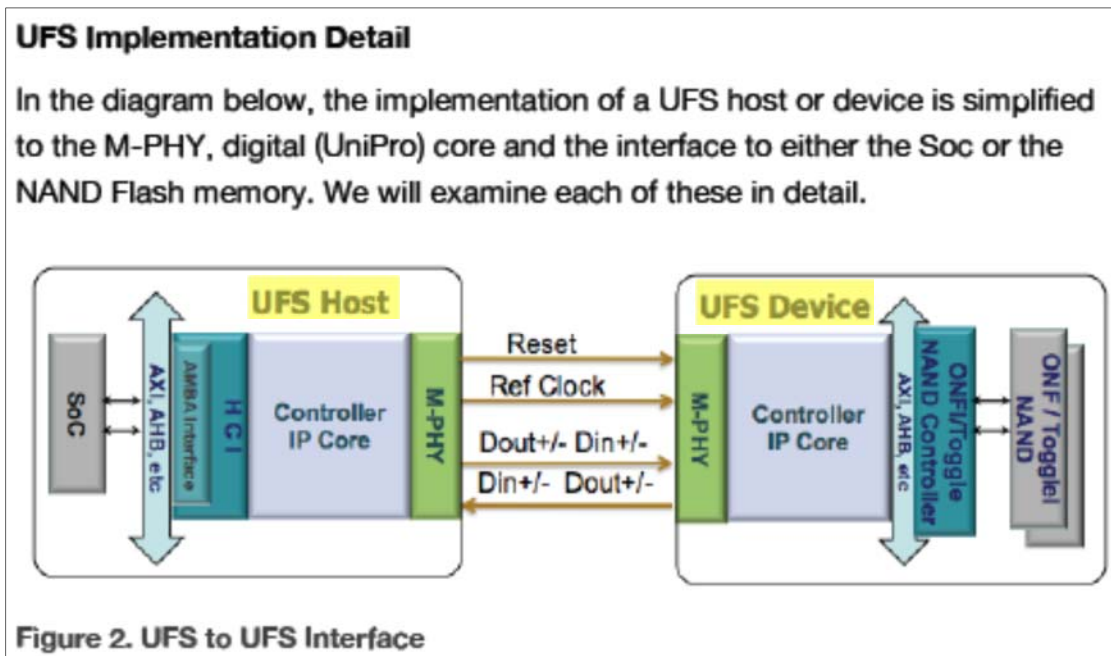

Arasan Chip Systems Inc. White Paper, “Universal Flash Storage: Mobilize Your Data” at 6 (Oct. 2012).

M-PHY I/O

MIPI defines two types of M-PHY, type 1 and type 2. The UFS specification calls out type 1. M-PHY Type 1 uses NRZ signaling for HS and PWM signaling for LS, while type 2 uses NRZ signaling for both HS and LS.

UFS utilizes two speed modes, high-speed and low-speed. Low speed mode In Gear 1 is used upon power up or reset, then a transition occurs to high-speed gears for data transmission. The low speed gears and high-speed gears are listed here for your reference. UFS v1.1 has been ratified and supports HS Gear 2 running approximately @ 3Gbps per lane. The UFS spec also supports up to 4 lanes for higher throughput.

Id.

17. UFS hosts and devices, which are included in the '044 Accused Products, contain signal transmitters. These signal transmitters drive a DC-balanced differential signal for a communications channel. This signal is comprised of a pair of data signals: a positive (true) data signal and a negative (complement) data signal. These transmitters multiplex a pulse-width modulated clock signal, a data signal, and control signals to apply them to the communications channel.

18. The '044 Accused Products thus include each and every limitation of claim 1 of the '044 patent; accordingly, they literally infringe this claim. Google directly infringes the '044 patent by making, using, offering to sell, selling, and/or importing the '044 Accused Products. Google is thereby liable for direct infringement.

19. During discovery and development of its infringement contentions, Plaintiff may provide additional theories under which Google infringes the '044 patent besides the example provided above, including for the same product and using the same components identified above, and nothing in the example above is meant to limit the infringement allegations of Plaintiff or limit the interpretations of the claims or their terms.

20. At a minimum, Google has known that the '044 Accused Products infringe the '044 patent at least as early as the service date of this Original Complaint.

21. Upon information and belief, since at least the above-mentioned date when Google was on notice of its infringement, Google has actively induced, under U.S.C. § 271(b), third-party manufacturers, distributors, importers and/or consumers that purchase or sell the '044 Accused Products that include all of the limitations of one or more claims of the '044 patent to directly infringe one or more claims of the '044 patent by making, having made, using, offering for sale, selling, and/or importing the '044 Accused Products. Since at least the notice provided on the above-mentioned date, Google does so with knowledge, or with willful blindness of the fact, that the induced acts constitute infringement of the '044 patent. Upon information and belief, Google intends to cause, and has taken affirmative steps to induce, infringement by these third-party manufacturers, distributors, importers, and/or consumers by, inter alia, creating advertisements that promote the infringing use of the '044 Accused Products, creating established distribution channels for the '044 Accused Products into and within the United States, manufacturing the '044 Accused Products in conformity with U.S. laws and regulations, distributing or making available instructions or manuals for these products to purchasers and prospective buyers, and/or providing technical support, replacement parts, or services for these products to these purchasers in the United States. For example, Google provides technical support for the Pixel on its own website at the following web address: <https://support.google.com/pixelphone#topic=9153446>.

22. Super Interconnect has been damaged as a result of Google's infringing conduct described in this Count. Google is, thus, liable to Super Interconnect in an amount that adequately compensates Super Interconnect for Google's infringement, which, by law, cannot be less than a reasonable royalty, together with interest and costs as fixed by this Court under 35 U.S.C. § 284.

COUNT II

(INFRINGEMENT OF U.S. PATENT NO. 6,463,092)

23. Super Interconnect incorporates paragraphs 1 through 22 herein by reference.

24. Super Interconnect is the assignee of the '092 patent, entitled "System and Method for Sending and Receiving Data Signals Over A Clock Signal Line," with ownership of all substantial rights in the '092 patent, including the right to exclude others and to enforce, sue, and recover damages for past and future infringement. A true and correct copy of the '092 patent is attached as Exhibit B.

25. The '092 patent is valid, enforceable, and was duly issued in full compliance with Title 35 of the United States Code. The '092 patent issued from U.S. Patent Application No. 09/393,235.

26. To the extent any marking or notice was required by 35 U.S.C. § 287, Super Interconnect and all predecessors-in-interest to the '092 patent have complied with the requirements of that statute by providing actual or constructive notice to Google of its alleged infringement.

27. Google has and continues to directly and/or indirectly infringe (by inducing infringement and/or contributing to infringement) one or more claims of the '092 patent in this judicial district and elsewhere in the United States, including at least claims 1, 2, 5, 10, and 11 by, among other things, making, having made, using, offering for sale, selling, and/or importing electronic devices with Universal Flash Storage (UFS) that incorporate the fundamental technologies covered by the '092 patent. These products are referred to as the "'092 Accused Products." Examples of the '092 Accused Products include, but are not limited to, the Google Pixel and Google Pixel XL smartphones.

28. For example, the Google Pixel directly infringes claim 1 of the '029 patent, as shown in the below paragraphs.

29. An example of the Google Pixel is shown in the image below.

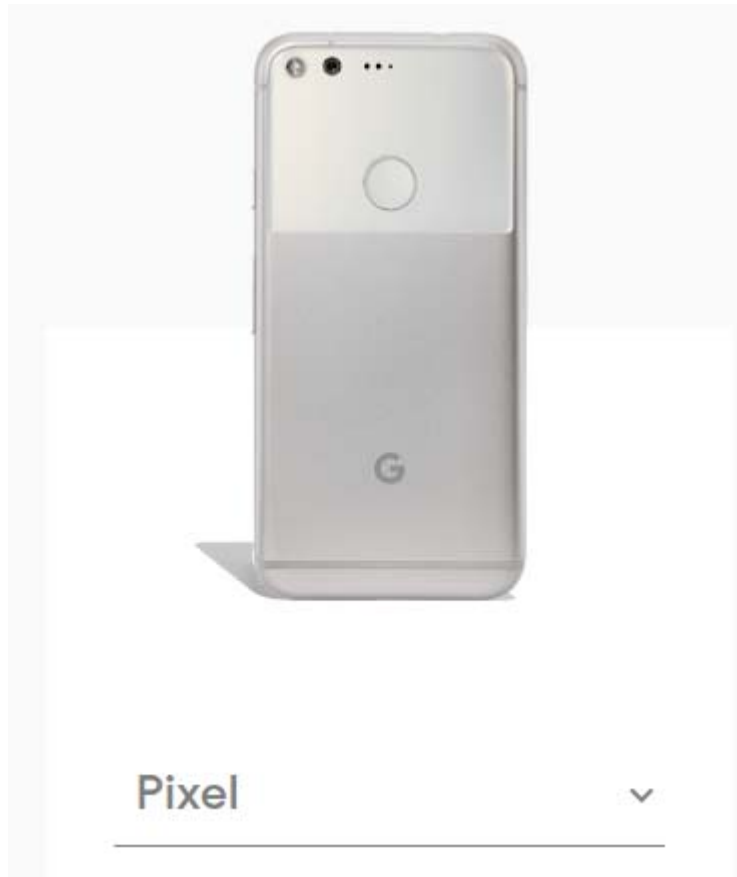

https://store.google.com/us/product/pixel_compare

30. Google incorporates UFS 2.0 storage in its Pixel family of products, as shown in the image below.

What makes the Pixel phones interesting, to me, is the relative lack of technical compromise. They have a fast processor. A fast camera (with improved and quicker HDR+). Fast storage (UFS 2.0). A fast fingerprint scanner. Fast software (they really are blazing-quick). Fast charging. Fast updates (seamless updates). A fast GPU (for VR). There is little about these phones you can point to and say Google cheated out on. And isn't that what so many of us have been demanding for years? A Google phone that could be positioned against the iPhone as legitimate competition (even if the iPhone does have its advantages - and disadvantages).

<http://www.androidpolice.com/2016/10/04/google-pixel-and-pixel-xl-hands-on-google-takes-on-the-iphone-by-becoming-the-iphone/>

31. The images below show that the Google Pixel’s UFS storage uses the MIPI M-PHY protocol for physical layer communication between the UFS host and the UFS device.

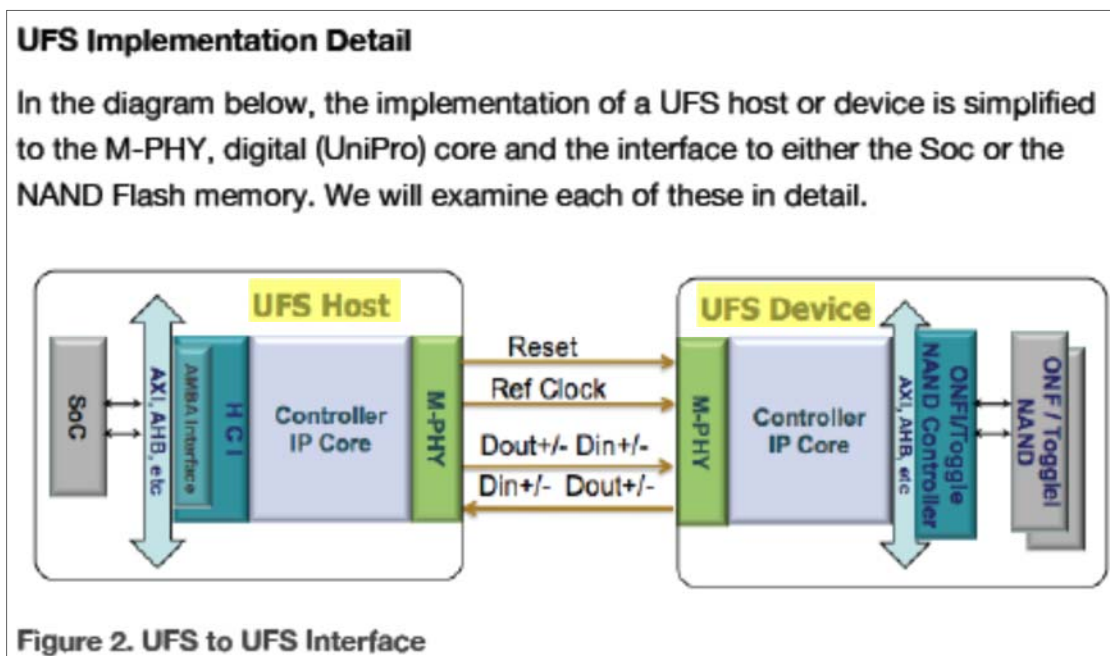

Arasan Chip Systems Inc. White Paper, “Universal Flash Storage: Mobilize Your Data” at 6 (Oct. 2012).

M-PHY I/O

MIPI defines two types of M-PHY, type 1 and type 2. The UFS specification calls out type 1. M-PHY Type 1 uses NRZ signaling for HS and PWM signaling for LS, while type 2 uses NRZ signaling for both HS and LS.

UFS utilizes two speed modes, high-speed and low-speed. Low speed mode In Gear 1 is used upon power up or reset, then a transition occurs to high-speed gears for data transmission. The low speed gears and high-speed gears are listed here for your reference. UFS v1.1 has been ratified and supports HS Gear 2 running approximately @ 3Gbps per lane. The UFS spec also supports up to 4 lanes for higher throughput.

Id.

32. UFS hosts and devices, which are included in the '092 Accused Products, multiplex clock and data signals for transmission over a single communications channel. This clock signal

is modulated based on the data to be transmitted before being combined with the output data stream.

33. The '092 Accused Products thus include each and every limitation of claim 1 of the '092 patent; accordingly, they literally infringe this claim. Google directly infringes the '092 patent by making, using, offering to sell, selling, and/or importing the '092 Accused Products. Google is thereby liable for direct infringement.

34. During discovery and development of its infringement contentions, Plaintiff may provide additional theories under which Google infringes the '092 patent besides the example provided above, including for the same product and using the same components identified above, and nothing in the example above is meant to limit the infringement allegations of Plaintiff or limit the interpretations of the claims or their terms.

35. At a minimum, Google has known that the '092 Accused Products infringe the '092 patent at least as early as the service date of this Original Complaint.

36. Upon information and belief, since at least the above-mentioned date when Google was on notice of its infringement, Google has actively induced, under U.S.C. § 271(b), third-party manufacturers, distributors, importers and/or consumers that purchase or sell the '092 Accused Products that include all of the limitations of one or more claims of the '092 patent to directly infringe one or more claims of the '092 patent by making, having made, using, offering for sale, selling, and/or importing the '092 Accused Products. Since at least the notice provided on the above-mentioned date, Google does so with knowledge, or with willful blindness of the fact, that the induced acts constitute infringement of the '092 patent. Upon information and belief, Google intends to cause, and has taken affirmative steps to induce, infringement by these third-party manufacturers, distributors, importers, and/or consumers by, inter alia, creating advertisements

that promote the infringing use of the '092 Accused Products, creating established distribution channels for the '092 Accused Products into and within the United States, manufacturing the '092 Accused Products in conformity with U.S. laws and regulations, distributing or making available instructions or manuals for these products to purchasers and prospective buyers, and/or providing technical support, replacement parts, or services for these products to these purchasers in the United States. For example, Google provides technical support for the Pixel on its own website at the following web address: <https://support.google.com/pixelphone#topic=9153446>.

37. Super Interconnect has been damaged as a result of Google's infringing conduct described in this Count. Google is, thus, liable to Super Interconnect in an amount that adequately compensates Super Interconnect for Google's infringement, which, by law, cannot be less than a reasonable royalty, together with interest and costs as fixed by this Court under 35 U.S.C. § 284.

COUNT III

(INFRINGEMENT OF U.S. PATENT NO. 7,158,593)

38. Super Interconnect incorporates paragraphs 1 through 37 herein by reference.

39. Super Interconnect is the assignee of the '593 patent, entitled "Combining a Clock Signal and a Data Signal," with ownership of all substantial rights in the '593 patent, including the right to exclude others and to enforce, sue, and recover damages for past and future infringement. A true and correct copy of the '593 patent is attached as Exhibit C.

40. The '593 patent is valid, enforceable, and was duly issued in full compliance with Title 35 of the United States Code. The '593 patent issued from U.S. Patent Application No. 10/099,533.

41. To the extent any marking or notice was required by 35 U.S.C. § 287, Super Interconnect and all predecessors-in-interest to the '593 patent have complied with the

requirements of that statute by providing actual or constructive notice to Google of its alleged infringement.

42. Google has and continues to directly and/or indirectly infringe (by inducing infringement and/or contributing to infringement) one or more claims of the '593 patent in this judicial district and elsewhere in the United States, including at least claims 34 and 35, by, among other things, making, having made, using, offering for sale, selling, and/or importing electronic devices with Universal Flash Storage (UFS) that incorporate the fundamental technologies covered by the '593 patent. These products are referred to as the "'593 Accused Products." Examples of the '593 Accused Products include, but are not limited to, the Google Pixel and Pixel XL smartphones.

43. The Google Pixel directly infringes claim 34 of the '593 patent, as shown in the below paragraphs.

44. An example of the Google Pixel is shown in the image below.

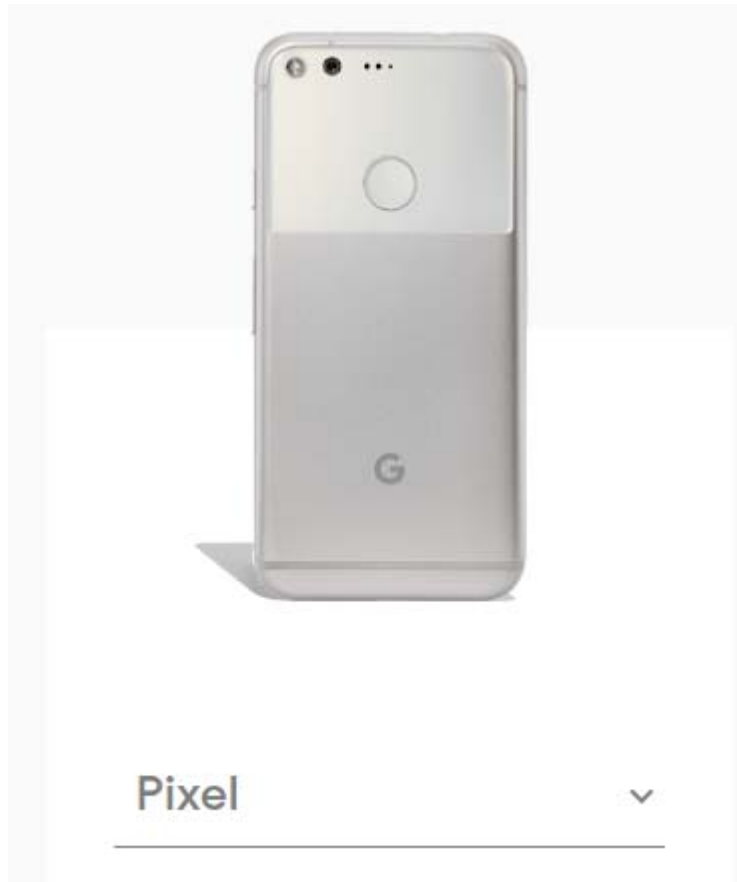

https://store.google.com/us/product/pixel_compare

45. Google incorporates UFS 2.0 storage in its Pixel family of products, as shown in the image below.

What makes the Pixel phones interesting, to me, is the relative lack of technical compromise. They have a fast processor. A fast camera (with improved and quicker HDR+). Fast storage (UFS 2.0). A fast fingerprint scanner. Fast software (they really are blazing-quick). Fast charging. Fast updates (seamless updates). A fast GPU (for VR). There is little about these phones you can point to and say Google cheated out on. And isn't that what so many of us have been demanding for years? A Google phone that could be positioned against the iPhone as legitimate competition (even if the iPhone does have its advantages - and disadvantages).

<http://www.androidpolice.com/2016/10/04/google-pixel-and-pixel-xl-hands-on-google-takes-on-the-iphone-by-becoming-the-iphone/>

46. The images below show that the Google Pixel's UFS storage uses the MIPI M-PHY protocol for physical layer communication between the UFS host and the UFS device.

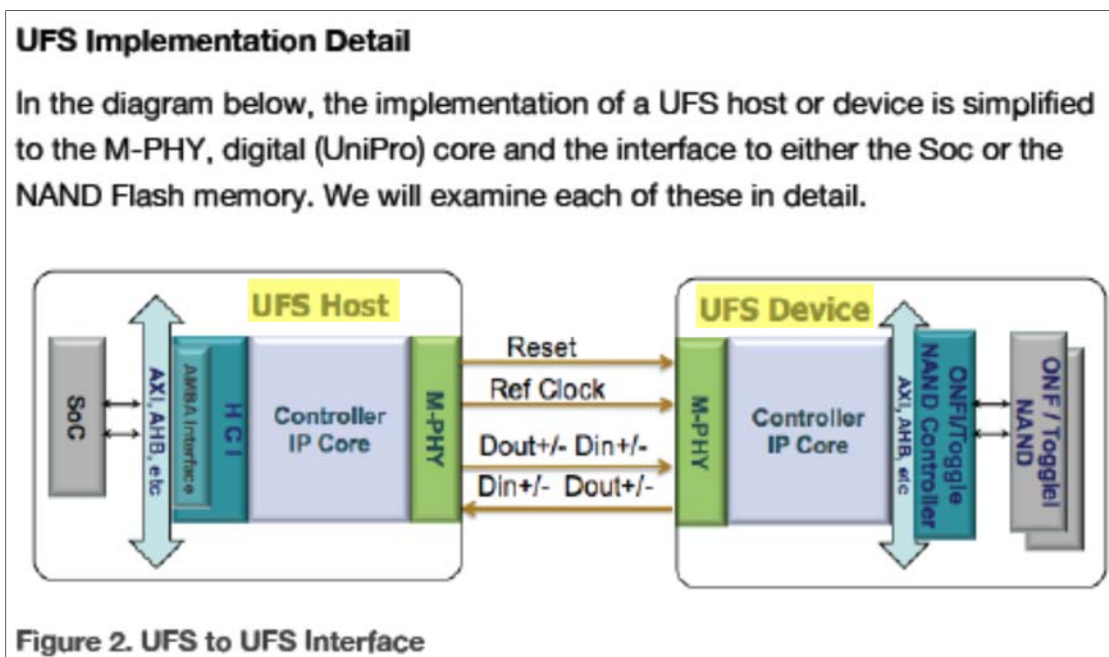

Arasan Chip Systems Inc. White Paper, “Universal Flash Storage: Mobilize Your Data” at 6 (Oct. 2012).

M-PHY I/O

MIPI defines two types of M-PHY, type 1 and type 2. The UFS specification calls out type 1. M-PHY Type 1 uses NRZ signaling for HS and PWM signaling for LS, while type 2 uses NRZ signaling for both HS and LS.

UFS utilizes two speed modes, high-speed and low-speed. Low speed mode In Gear 1 is used upon power up or reset, then a transition occurs to high-speed gears for data transmission. The low speed gears and high-speed gears are listed here for your reference. UFS v1.1 has been ratified and supports HS Gear 2 running approximately @ 3Gbps per lane. The UFS spec also supports up to 4 lanes for higher throughput.

Id.

47. UFS hosts and devices, which are included in the '593 Accused Products, contain signal transmitters. These transmitters encode the data to be transmitted and further multiplex a pulse-width modulated clock signal, an encoded data signal, and control signals to apply them to the communications channel. This encoding scheme shifts an energy spectrum of the combined clock and encoded data signal away from an effective loop bandwidth of a clock recovery block.

48. The '593 Accused Products thus include each and every limitation of claim 34 of the '593 patent; accordingly, they literally infringe this claim. Google directly infringes the '593 patent by making, using, offering to sell, selling, and/or importing the '593 Accused Products. Google is thereby liable for direct infringement.

49. During discovery and development of its infringement contentions, Plaintiff may provide additional theories under which Google infringes the '593 patent besides the example provided above, including for the same product and using the same components identified above, and nothing in the example above is meant to limit the infringement allegations of Plaintiff or limit the interpretations of the claims or their terms.

50. At a minimum, Google has known that the '593 Accused Products infringe the '593 patent at least as early as the service date of this Original Complaint.

51. Upon information and belief, since at least the above-mentioned date when Google was on notice of its infringement, Google has actively induced, under U.S.C. § 271(b), third-party manufacturers, distributors, importers and/or consumers that purchase or sell the '593 Accused Products that include all of the limitations of one or more claims of the '593 patent to directly infringe one or more claims of the '593 patent by making, having made, using, offering for sale, selling, and/or importing the '593 Accused Products. Since at least the notice provided on the above-mentioned date, Google does so with knowledge, or with willful blindness of the fact, that the induced acts constitute infringement of the '593 patent. Upon information and belief, Google intends to cause, and has taken affirmative steps to induce, infringement by these third-party manufacturers, distributors, importers, and/or consumers by, *inter alia*, creating advertisements that promote the infringing use of the '593 Accused Products, creating established distribution channels for the '593 Accused Products into and within the United States, manufacturing the '593

Accused Products in conformity with U.S. laws and regulations, distributing or making available instructions or manuals for these products to purchasers and prospective buyers, and/or providing technical support, replacement parts, or services for these products to these purchasers in the United States. For example, Google provides technical support for the Pixel on its own website at the following web address: <https://support.google.com/pixelphone#topic=9153446>.

52. Super Interconnect has been damaged as a result of Google's infringing conduct described in this Count. Google is, thus, liable to Super Interconnect in an amount that adequately compensates Super Interconnect for Google's infringement, which, by law, cannot be less than a reasonable royalty, together with interest and costs as fixed by this Court under 35 U.S.C. § 284.

JURY DEMAND

Super Interconnect hereby requests a trial by jury pursuant to Rule 38 of the Federal Rules of Civil Procedure.

PRAYER FOR RELIEF

Super Interconnect requests that the Court find in its favor and against Google, and that the Court grant Google the following relief:

- a. Judgment that one or more claims of the '044, '092, and '593 patents have been infringed, either literally and/or under the doctrine of equivalents, by Google and/or by others whose infringement has been induced by Google;
- b. Judgment that Google account for and pay to Super Interconnect all damages to and costs incurred by Super Interconnect because of Google's infringing activities and other conduct complained of herein;
- c. Judgment that Google account for and pay to Super Interconnect a reasonable, ongoing, post-judgment royalty because of Google's infringing activities and other conduct complained of herein;
- d. Judgment that Google's conduct warrants that the Court award treble damages pursuant to 35 U.S.C. § 284;
- e. Judgment that Super Interconnect be granted pre-judgment and post-judgment

interest on the damages caused by Google's infringing activities and other conduct complained of herein;

- f. Judgment and an order finding this to be an exceptional case and requiring Google to pay the costs of this action (including all disbursements) and attorneys' fees as provided by 35 U.S.C. § 285; and
- g. That Super Interconnect be granted such other and further relief as the Court may deem just and proper under the circumstances.

Dated: November 2, 2018

Respectfully submitted,

/s/ Jeffrey R. Bragalone w/permission
Wesley Hill

Jeffrey R. Bragalone
Texas Bar No. 02855775
LEAD ATTORNEY
T. William Kennedy Jr.
Texas Bar No. 24055771
Brian P. Herrmann
Texas Bar No. 24083174

Bragalone Conroy PC
2200 Ross Avenue
Suite 4500W
Dallas, TX 75201
Tel: (214) 785-6670
Fax: (214) 785-6680
jbragalone@bcpc-law.com
bkennedy@bcpc-law.com
bherrmann@bcpc-law.com

OF COUNSEL:

Wesley Hill
State Bar No. 24032294
Ward, Smith & Hill, PLLC
PO Box 1231
Longview, Texas 75606-1231
(903) 757-6400 (telephone)
(903) 757-2323 (facsimile)
wh@wsfirm.com