

**IN THE UNITED STATES DISTRICT COURT
FOR THE NORTHERN DISTRICT OF TEXAS
DALLAS DIVISION**

CHRIMAR SYSTEMS, INC.,
d/b/a CMS TECHNOLOGIES and
CHRIMAR HOLDING COMPANY, LLC,

Plaintiffs,

v.

USA VISION SYSTEMS INC.,
Defendant.

Civil Action No. 3:19-cv-00114

JURY TRIAL DEMANDED

COMPLAINT FOR PATENT INFRINGEMENT

Plaintiffs Chrimar Systems, Inc. d/b/a CMS Technologies (“Chrimar Systems”) and Chrimar Holding Company, LLC (“Chrimar Holding”) (collectively, “Chrimar” or “Plaintiffs”) file this Complaint against Defendant USA Vision Systems, Inc. (“Defendant”) for infringement of U.S. Patents Nos. 8,942,107 (the “’107 Patent”), 9,812,825 (the “’825 Patent”), 8,902,760 (the “’760 Patent”), and 9,019,838 (the “’838 Patent”), and hereby allege as follows:

NATURE OF THE ACTION

1. This is an action for patent infringement arising under the Patent Laws of the United States, 35 U.S.C. §§ 1, *et seq.*

PARTIES

2. Plaintiff Chrimar Systems, Inc. d/b/a CMS Technologies is a Michigan corporation with a place of business located at 36528 Grand River Avenue, Suite A-1, Farmington Hills, Michigan 48335.

3. Plaintiff Chrimar Holding Company, LLC is a Texas limited liability company with a place of business located at 911 NW Loop 281, Suite 211-30, Longview, Texas 75604.

4. Chrimar was the first company to employ DC current within a BaseT network in the early 1990s and has received a number of US patents for this very important technology. Chrimar continues to market its EtherLock® family of products for asset control, management and security, including the EtherLock® II and EtherLock Identification (ELID) products:

EtherLock® II

EtherLock® II is a centralized piece of equipment which applies DC current to the physical layer, to continuously monitor the physical connection, receive distinguishing information about Ethernet end devices and provide notification, etc.



ELID

The EtherLock IDentification device or ELID device works in conjunction with the EtherLock II unit allowing for real-time identification and tracking of a computers' physical location on an Ethernet network providing absolute control over what equipment connects to your data network. The ELID device also allows for a complete location-based inventory of all your assets even if the assets are powered off.



http://cmstech.com/security_solutions/products/products.html

5. Chrimar's EtherLock® II product practices certain claims of the '838 Patent, and the installed ELID/NIC-Stick circuitry practice certain claims of the '107, '760, and '825 Patents.

See also <http://www.cm spatents.com/>.

6. Chrimar has entered into numerous non-exclusive licenses for certain equipment under certain Chrimar patents including certain Power over Ethernet (PoE) equipment designed for deployment within a BaseT Ethernet network. See, e.g., <https://realtimepressrelease.com/press-releases-tagged-with/chrimar/>.

7. Upon information and belief, Defendant USA Vision Systems, Inc. is a California corporation having a place of business at 9235 Research Drive, Irvine, California 92618-4286, and can be served through its registered agent, Andrew Michie, 1555 Valwood Parkway, Suite 150, Carrollton, Texas 75006.

JURISDICTION AND VENUE

8. This Court has subject matter jurisdiction under 28 U.S.C. §§ 1331 and 1338(a).

9. Defendant is subject to this Court's specific and general personal jurisdiction due to its substantial business in this forum. For example, upon information and belief, Defendant is subject to the specific personal jurisdiction of this Court because Chrimar's claims for patent infringement arise from Defendant's acts of infringement in the State of Texas. These acts of infringement include selling infringing products in the State of Texas and placing infringing products into the stream of commerce through an established distribution channel with full awareness that substantial quantities of the products have been shipped into the State of Texas. Therefore, this Court has personal jurisdiction over Defendant under the Texas long-arm statute, TEX. CIV. PRAC. & REM. CODE § 17.042.

10. Venue is proper in this judicial district under 28 U.S.C. § 1400(b). Defendant has a regular and established place of business in this District at 1555 Valwood Parkway, Suite 150, Carrollton, Texas 75006 and has committed and continues to commit acts of infringement in this District. Defendant's regular and established place of business in Carrollton in this District is a physical building, and according to the Dallas County Central Appraisal District is 100% owned by USA Vision Systems Inc. *See In re Cray Inc.*, 871 F.3d 1355, 1360 (Fed. Cir. 2017).

The screenshot shows the 'REACH US BY PHONE' page on the GeoVision website. The page lists contact details for offices in Taiwan, California, New York, Indiana, Texas, and Quebec. Each office listing includes the company name, address, telephone number, fax number, and email address.

Location	Company Name	Address	Tel	Fax	Email
Taiwan	GeoVision, Inc. Headquarter	9F., No. 246, Sec. 1, Neihsu Rd., Neihu District, Taipei 114, Taiwan	+886-2-8797-8376	+886-2-8797-5861	sales@geovision.com.tw
USA California	USA Vision Systems Inc.	9301 Irvine Blvd, Irvine, CA 92618, USA	+1-949-583-1519	+1-949-583-1522	sales@usavisionsys.com
USA New York	USA Vision Systems Inc. Sales Office	333 Westchester Ave. White Plains, NY 10604, USA	+1-845-661-0443	+1-949-583-1522	sales@usavisionsys.com
USA Indiana	USA Vision Systems Inc. Sales Office	12550 Promise Creek Lane Suite 106 Fishers, IN 46038, USA	+1-949-583-1519	+1-949-583-1522	sales@usavisionsys.com
USA Texas	USA Vision Systems Inc. Sales Office	1555 Valwood Parkway Ste. 150 Carrollton, TX 75006, USA	+1-949-583-1519	+1-949-583-1522	sales@usavisionsys.com
Canada Quebec	USA Vision Systems Inc. Sales Office	3353 Rue Griffith Saint-Laurent QC H4T 1W5, Canada	+1-514-687-9970	+1-949-583-1522	GVCCanada@usavisionsys.com

http://www.geovision.com.tw/contact_phone.php

< PREV matches 1 - 1 of 1 properties. NEXT >					Page 1 of 1
#	Property Address	City	Owner Name / Business Name	Total Value	Type
1	1555 VALWOOD PKWY Suite: 150	CARROLLTON	USA VISION SYSTEMS INC DBA: USA VISION SYSTEMS INC	\$121,340	BPP
< PREV matches 1 - 1 of 1 properties. NEXT >					Page 1 of 1

<http://www.dallascad.org/searchowner.aspx>

PATENTS-IN-SUIT

11. Chrimar Systems is the owner and the assignee of U.S. Patent No. 8,942,107, entitled “Piece of Ethernet Terminal Equipment” and Chrimar Holding holds the exclusive right to license the `107 Patent. Chrimar has ownership of all substantial rights in the `107 Patent, including the right to exclude others and to enforce, sue and recover damages for past and future infringement. A true and correct copy of the `107 Patent is attached as Exhibit A.

12. The `107 Patent is valid, enforceable and was duly issued in full compliance with Title 35 of the United States Code.

13. Chrimar Systems is the owner and assignee of U.S. Patent No. 9,812,825, entitled “Ethernet Device” and Chrimar Holding holds the exclusive right to license the `825 Patent. Chrimar has ownership of all substantial rights in the `825 Patent, including the right to exclude others and to enforce, sue and recover damages for past and future infringement. A true and correct copy of the `825 Patent is attached as Exhibit B.

14. The `825 Patent is valid, enforceable and was duly issued in full compliance with Title 35 of the United States Code.

15. Chrimar Systems is the owner and assignee of U.S. Patent No. 8,902,760, entitled “Network System and Optional Tethers” and Chrimar Holding holds the exclusive right to license the `760 Patent. Chrimar has ownership of all substantial rights in the `760 Patent, including the right to exclude others and to enforce, sue and recover damages for past and future infringement. A true and correct copy of the `760 Patent is attached as Exhibit C.

16. The `760 Patent is valid, enforceable and was duly issued in full compliance with Title 35 of the United States Code.

17. Chrimar Systems is the owner and the assignee of U.S. Patent No. 9,019,838, entitled “Central Piece of Network Equipment” and Chrimar Holding holds the exclusive right to

license the '838 Patent. Chrimar has ownership of all substantial rights in the '838 Patent, including the right to exclude others and to enforce, sue and recover damages for past and future infringement. A true and correct copy of the '838 Patent is attached as Exhibit D.

18. The '838 Patent is valid, enforceable and was duly issued in full compliance with Title 35 of the United States Code.

19. The '107, '825, '760, and '838 Patents are collectively the "Patents-in-Suit."

20. The Patents-in-Suit generally cover plug and play automation and/or asset control capabilities employed by certain BaseT Ethernet equipment including powered devices ("PDs"), power sourcing equipment ("PSEs"), and midspans/injectors that comply with or are compatible with certain portions of the IEEE Standards commonly referred to as PoE Standards (e.g., the IEEE 802.3af or IEEE 802.3at standards).

ACCUSED PRODUCTS

21. Upon information and belief, Defendant makes, uses, offers to sell, sells, and/or imports Power over Ethernet powered devices and/or power sourcing equipment. Defendant's Accused Products are divisible into two categories.

22. The first category is Accused Powered Devices ("Accused PD Products"). The Accused PDs are equipment (e.g., IP Cameras) that receive an interrogation signal as well as phantom power to operate via their Ethernet port. Exemplary explanations of how the Accused PDs infringe are provided in the patent specific infringement counts below. The Accused PDs include, but are not limited to: GV-VR360, GVAVD2700, GV-AVD4710, GV-AVD8710, GV-SV48000, GV-ADR4701, GV-ADR2701, GV-VD8700, GV-VD5711, GV-VD5700, GV-VD4711, GV-VD4702, GV-VD2712, GV-VD2702, GV-MFD4700, GV-MFD2700, GV-FD4700, GV-FD2700, GV-ABL8712, GV-ABL4712, GV-ABL4701, GV-ABL2701, GV-ABL2702, GV-

BL5713, GV-BL4702, GV-BL4713, GV-BL2702, GV-FER12203, GV-FER5700, GV-BX12201, UVS-ABD1300, GV-EBD2702, GV-EBD8711, GV-PPTZ7300, GV-PPTZ14021, GV-PPTZ14031, GV-UNP2500, GV-UNFE2503, and GV-TM0100.

23. The second category is Accused Power Sourcing Equipment (“Accused PSE Products”). The Accused PSEs include devices that send an interrogation signal and provide power to other devices by way of an Ethernet port, such as PoE (Power over Ethernet) switches, midspans/injectors, and network video recorders (“NVRs”). The Accused PDs include, but are not limited to: GV-POE0400-V2, GV-POE-0800, GV-POE0801, GV-POE1601-V2, GV-POE2401-V2, GV-POE0410-E, GV-POE0810, GV-POE0811-V2, GV-POE0812, GV-POE1611-V2, and GV-POE2411.

24. Collectively, the Accused PD Products and the Accused PSE Products comprise the “Accused Products.” Upon information and belief, the Accused Products are offered for sale and sold throughout the United States, including within this District.

25. Upon information and belief, Defendant has purposefully and voluntarily placed the Accused Products into the stream of commerce with the expectation that these products will be purchased and used by end users in the United States, including end users in this District.

26. Upon information and belief, Defendant provides direct and indirect support concerning the Accused Products to end users, including end users within this District.

COUNT I
INFRINGEMENT OF U.S. PATENT NO. 8,942,107

27. Chrimar alleges and hereby incorporates by reference every allegation made in the foregoing paragraphs of this Complaint as if each were separately set forth herein.

28. In violation of 35 U.S.C. § 271, Defendant has directly infringed and continue to directly infringe, both literally and/or under the doctrine of equivalents, the `107 Patent by making,

using, offering for sale, selling, and/or importing the Accused PD Products in the United States, including within this District, that infringe at least claim 103 across claims 6, 16, 56, 71, and 87; and claim 125 across claims 113 and 122 of the `107 Patent without the authority of Chrimar.

29. The identified claims of the `107 Patent are presumed valid.

30. Each of the Accused PD Products is a piece of BaseT Ethernet data terminal equipment. For example, the representative Geovision GV-VR360 Network Camera is a device that can originate and terminate Ethernet data and Ethernet data transmissions, and is configured to communicate with other devices over a BaseT Ethernet network via Ethernet signals.

Network	
Interface	10/100 Ethernet
Protocol	DHCP, DNS, DynDNS, HTTP, HTTPS, IPv4, NTP, ONVIF (Profile S), RTSP, SMTP, TCP/IP, UDP

https://s3.amazonaws.com/geovision_downloads/Manual/IPCAM/Datasheet/VR/Datasheet_IPCa_mH265VR360.pdf, p. 3.

31. Each of the Accused PD Products has an Ethernet connector comprising first and second pairs of contacts. For example, the representative Geovision GV-VR360 Network Camera has an RJ-45 Ethernet connector (labelled “Ethernet (LAN) port”), which has four pairs of contacts:

Mechanical		
Temperature Detector	N/A	
Power	DC 12V, 1.25A, DC Jack / PoE	
	Ethernet	10/100 Base-T, RJ-45 Connector
Connectors	Audio	1 in (built-in or external microphone with power supply)
	Digital I/O	I/O wires
	Local Storage	N/A

https://s3.amazonaws.com/geovision_downloads/Manual/IPCAM/Datasheet/VR/Datasheet_IPCa_mH265VR360.pdf, p. 3.

Power Source	DC 12V / PoE (PoE+, IEEE 802.3at)
--------------	-----------------------------------

Id.

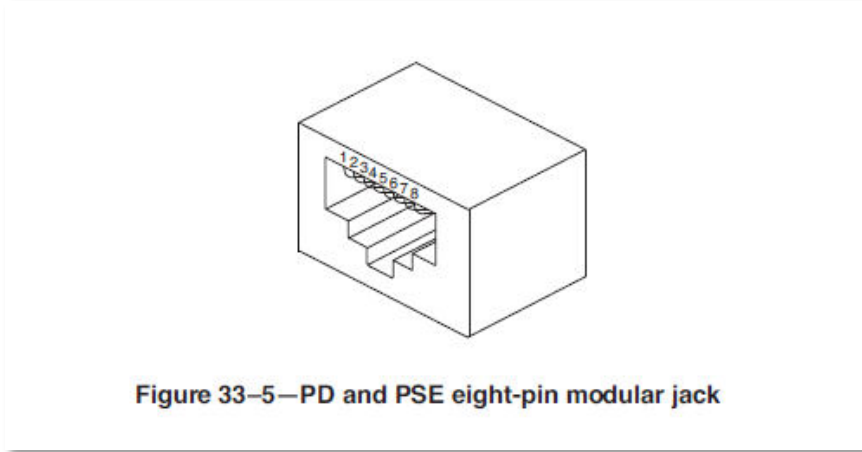

IEEE 802.3af standard, Figure 33-5

32. Each of the Accused PD Products uses an Ethernet connector’s first and second pairs of contacts to carry Ethernet communication signals. For example, the pairs of contacts of the Ethernet connector of the Geovision GV-VR360 Network Camera can carry 10BaseT and 100BaseTX Ethernet communication data signals:

Mechanical		
Temperature Detector		N/A
	Power	DC 12V, 1.25A, DC Jack / PoE
	Ethernet	10/100 Base-T, RJ-45 Connector
Connectors	Audio	1 in (built-in or external microphone with power supply)
	Digital I/O	I/O wires
	Local Storage	N/A

https://s3.amazonaws.com/geovision_downloads/Manual/IPCAM/Datasheet/VR/Datasheet_IPCa_mH265VR360.pdf, p. 3.

33. Each of the Accused PD Products is a powered-off end device prior to receiving any of its operating power. For example, the Geovision GV-VR360 Network Camera is a powered-off end device when requesting its operating power or when it is not physically connected to the network.

34. Each of the Accused PD Products has at least one path for the purpose of drawing DC current, the at least one path coupled across at least one of the contacts of the first pair of

contacts and at least one of the contacts of the second pair of contacts of its Ethernet connector. For example, the representative Geovision GV-VR360 Network Camera claims compliance with the IEEE 802.3at standard:

Power Source DC 12V / PoE (PoE+, IEEE 802.3at)
https://s3.amazonaws.com/geovision_downloads/Manual/IPCAM/Datasheet/VR/Datasheet_IPCa_mH265VR360.pdf, p. 3. The IEEE 802.3at standard is in all material respects compatible with the IEEE 802.3af standard.

35. The IEEE 802.3af standard explains:

33.3.1 PD PI

The PD shall be capable of accepting power on either of two sets of PI conductors. The two conductor sets are named Mode A and Mode B. In each four-wire connection, the two wires associated with a pair are at the same nominal average voltage. Figure 33-5 in conjunction with Table 33-7 illustrates the two power modes.

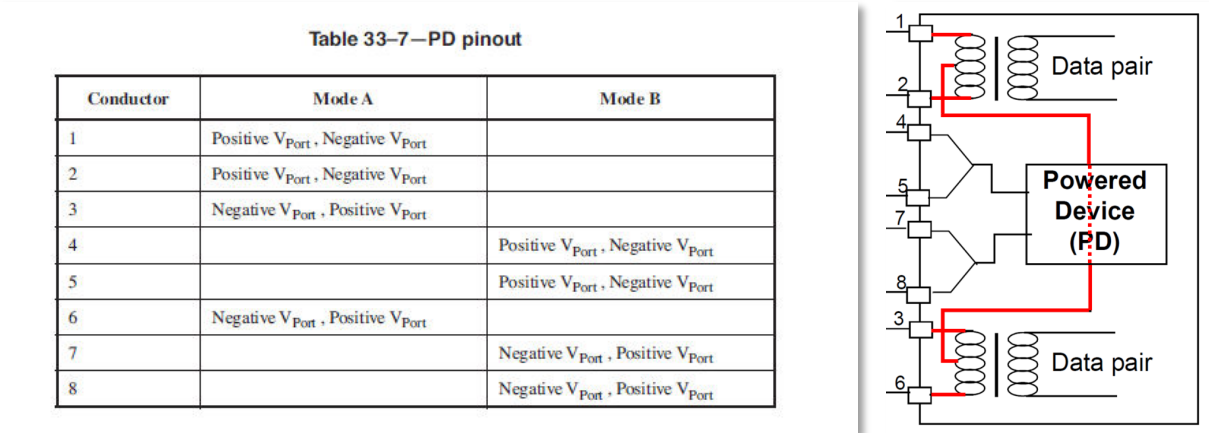

IEEE 802.3af standard, 33.3.1, Table 33-7, and Figure 33-4 (annotated, emphasis added).

36. Each Accused PD Product draws different magnitudes of DC current flow via the at least one path, the different magnitudes of DC current flow to result from at least one condition (e.g., voltage or current) applied to at least one of the contacts of the first and second pairs of contacts of its Ethernet connector. For example, the representative Geovision GV-VR360 Network Camera claims compliance with the IEEE 802.3at standard. See

https://s3.amazonaws.com/geovision_downloads/Manual/IPCAM/Datasheet/VR/Datasheet_IPCa_mH265VR360.pdf, p. 3. The IEEE 802.3at standard is backwards compatible with the

IEEE 802.3af standard in all relevant respects. IEEE 802.3af explains:

33.3.3 PD valid and non-valid detection signatures

A PD shall present a valid detection signature at the PI between Positive V_{Port} and Negative V_{Port} of PD Mode A and between Positive V_{Port} and Negative V_{Port} of PD Mode B as defined in 33.3.1 while it is in a state where it will accept power via the PI, but is not powered via the PI.

A PD shall present a non-valid detection signature at the PI between Positive V_{Port} and Negative V_{Port} of PD Mode A and between Positive V_{Port} and Negative V_{Port} of PD Mode B as defined in 33.3.1 while it is in a state where it will not accept power via the PI.

When a PD becomes powered via the PI, it shall present a non-valid detection signature on the set of pairs from which is it not drawing power.

The valid and non-valid detection signature regions are separated by guardbands. The guardbands for the V-I slope are the ranges 12K Ω to 23.75K Ω and 26.25K Ω to 45K Ω . A PD that presents a signature in a guardband is non-compliant.

V-I slope is the effective resistance calculated from the two voltage/current measurements made during the detection process.

$$V-I \text{ slope} = (V_2 - V_1) / (I_2 - I_1) \quad (33-1)$$

where (V_1, I_1) and (V_2, I_2) are measurements made at the PD PI.

The valid PD detection signature shall have the characteristics of Table 33-8.

IEEE 802.3af standard, 33.3.3

37. Each of the Accused PD Products can convey information about itself (e.g., while powered-off) via magnitudes of the DC current flow. For example, the representative Geovision GV-VR360 Network Camera claims compliance with the IEEE 802.3at standard. *See* https://s3.amazonaws.com/geovision_downloads/Manual/IPCAM/Datasheet/VR/Datasheet_IPCa_mH265VR360.pdf, p. 3. The IEEE 802.3at standard is backwards compatible with the

IEEE 802.3af standard in all relevant respects. IEEE 802.3af explains:

The Power Sourcing Equipment (PSE) is located at an endpoint or midspan, separate from and between the MDIs, and provides power to the Powered Device (PD) over the Link Section. The PSE detection protocol distinguishes a compatible

PD from non-compatible devices and precludes the application of power and possible damage to non-compatible devices.”

Table 33–8— Valid PD detection signature characteristics, measured at PD input connector

Parameter	Conditions	Minimum	Maximum	Unit
V-I Slope (at any 1V or greater chord within the voltage range conditions)	2.7V to 10.1V	23.75	26.25	K Ω
V offset			1.9	V
I offset			10	μ A
Input capacitance	2.7V to 10.1 V	0.05	0.12	μ F
Input inductance	2.7V to 10.1 V		100	μ H

A non-valid detection signature shall have one or both of the characteristics in Table 33–9

Table 33–9— Non-valid PD detection signature characteristics, measured at PD input connector

Parameter	Conditions	Range of values	Unit
V-I Slope	V < 10.1V	Either greater than 45 or less than 12	K Ω
Input Capacitance	V < 10.1V	Greater than 10	μ F

IEEE 802.3af standard, Abstract, Table 33-8, and Table 33-9

38. Upon information and belief, discovery will show that the at least one path is integrated into each of the Accused PD Products.

39. Each of the Accused PD Products (e.g., while powered-off, i.e., without any of its operating power) can draw different magnitudes of DC current flow via at least one of the contacts of the first and second pairs of contacts of its Ethernet connector. For example, the representative Geovision GV-VR360 Network Camera claims compliance with the IEEE 802.3at standard. *See* https://s3.amazonaws.com/geovision_downloads/Manual/IPCAM/Datasheet/VR/Datasheet_IPCa_mH265VR360.pdf, p. 3. The IEEE 802.3at standard is backwards compatible with the

IEEE 802.3af standard in all relevant respects. The IEEE 802.3af standard prescribes the presentation of valid detection signatures by drawing different magnitudes of DC current flow in response to at least one electrical condition (e.g. a voltage or current) applied to a contact:

33.3.3 PD valid and non-valid detection signatures

A PD shall present a valid detection signature at the PI between Positive V_{Port} and Negative V_{Port} of PD Mode A and between Positive V_{Port} and Negative V_{Port} of PD Mode B as defined in 33.3.1 while it is in a state where it will accept power via the PI, but is not powered via the PI.

A PD shall present a non-valid detection signature at the PI between Positive V_{Port} and Negative V_{Port} of PD Mode A and between Positive V_{Port} and Negative V_{Port} of PD Mode B as defined in 33.3.1 while it is in a state where it will not accept power via the PI.

When a PD becomes powered via the PI, it shall present a non-valid detection signature on the set of pairs from which is it not drawing power.

The valid and non-valid detection signature regions are separated by guardbands. The guardbands for the V-I slope are the ranges 12K Ω to 23.75K Ω and 26.25K Ω to 45K Ω . A PD that presents a signature in a guardband is non-compliant.

V-I slope is the effective resistance calculated from the two voltage/current measurements made during the detection process.

$$V-I \text{ slope} = (V_2 - V_1) / (I_2 - I_1) \quad (33-1)$$

where (V_1, I_1) and (V_2, I_2) are measurements made at the PD PI.

The valid PD detection signature shall have the characteristics of Table 33-8.

Table 33–8— Valid PD detection signature characteristics, measured at PD input connector

Parameter	Conditions	Minimum	Maximum	Unit
V-I Slope (at any 1V or greater chord within the voltage range conditions)	2.7V to 10.1V	23.75	26.25	KΩ
V offset			1.9	V
I offset			10	μA
Input capacitance	2.7V to 10.1 V	0.05	0.12	μF
Input inductance	2.7V to 10.1 V		100	μH

A non-valid detection signature shall have one or both of the characteristics in Table 33–9

Table 33–9— Non-valid PD detection signature characteristics, measured at PD input connector

Parameter	Conditions	Range of values	Unit
V-I Slope	V < 10.1V	Either greater than 45 or less than 12	KΩ
Input Capacitance	V < 10.1V	Greater than 10	μF

IEEE 802.3af standard, 33.3.3, Table 33-8, and Table 33-9

40. Upon information and belief, discovery will show that each Accused PD Product has at least one path and the at least one path comprises at least two different impedances.

41. The DC current can comprise a first magnitude of DC current for a first interval followed by a second magnitude of DC current for a second interval, wherein the second magnitude is greater than the first magnitude. For example:

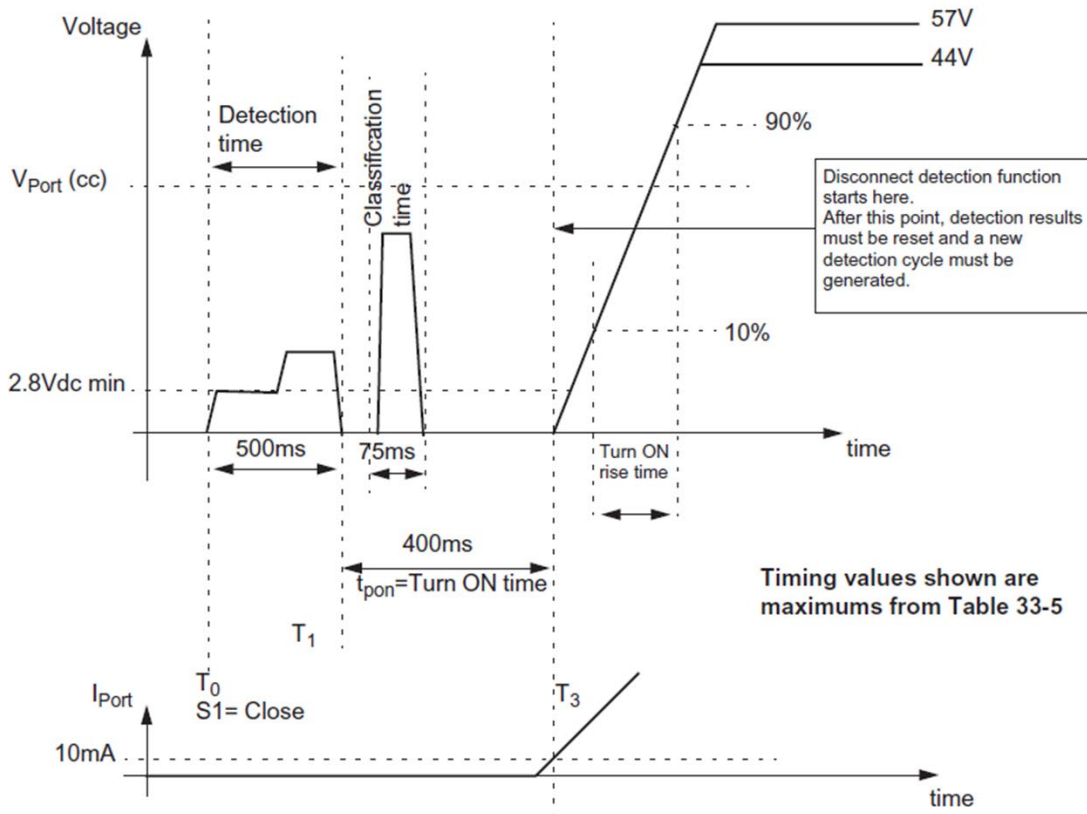

Figure 33C.11—Detection, classification, turn on, and total cycle timing relationships

IEEE 802.3af standard, Figure 33C.11

42. The first and second magnitudes of DC current can generally be used, for example, to distinguish a PD like the Accused PD Products from a non-PD or legacy device, and to identify each Accused PD Product’s power requirements.

43. Accordingly, Defendant has and continues to directly infringe the `107 Patent, both literally and/or under the doctrine of equivalents, in violation of 35 U.S.C. § 271(a) by making, using, offering for sale, selling, and/or importing into the United States the Accused Products without the authority of Chrimar.

44. Defendant has been on notice of the `107 Patent since at least filing of this Complaint. *See Script Sec. Sols. L.L.C. v. Amazon.com, Inc.*, 170 F. Supp. 3d 928, 937 (E.D. Tex. 2016).

45. In violation of 35 U.S.C. § 271(b), Defendant has indirectly infringed the `107 Patent by inducing its customers to directly infringe the `107 Patent, both literally and/or under the doctrine of equivalents, at least by providing its customers with instructions on using the Accused Products and by making, using, offering for sale, selling, and/or importing devices in the United States the Accused Products without the authority of Chrimar. For example, the representative Geovision GV-VR360 Network Camera's User Manual instructs:

- DC 12V / PoE (PoE+, IEEE 802.3at)

GV-VR360_User_Manual(VR360V101-UM-A), p. 2 and:

GV-PoE Switch	GV-PoE Switch is designed to provide power along with network connection for IP devices. GV-PoE Switch is available in various models with different numbers and types of ports.
---------------	--

Id at p. vii.

46. Upon information and belief, and in violation of 35 U.S.C. § 271(b), Defendant has indirectly infringed the `107 Patent by contribution knowing that the Accused Products would be combined with other components to infringe the `107 Patent and that the Accused Products have no substantial non-infringing use.

47. Unless enjoined by this Court, Defendant will continue to infringe the `107 Patent.

48. Because of Defendant's infringing activities, Chrimar has suffered damages and will continue to suffer damages in the future.

COUNT II
INFRINGEMENT OF U.S. PATENT NO. 9,812,825

49. Chrimar alleges and hereby incorporates by reference every allegation made in the foregoing paragraphs of this Complaint as if each were separately set forth herein.

50. The '825 Patent is presumed valid.

51. In violation of 35 U.S.C. § 271, Defendant has directly infringed and continue to directly infringe, both literally and/or under the doctrine of equivalents, the '825 Patent by making, using, offering for sale, selling, and/or importing the Accused PSE Products in the United States, including within this District, that infringe at least claims 5, 11, 13, 15, 16, 17, 40, 45, 49, 50, 64, and 68 of the '825 Patent without the authority of Chrimar. In further violation of 35 U.S.C. § 271, Defendant has directly infringed and continue to directly infringe, both literally and/or under the doctrine of equivalents, the '825 Patent by making, using, offering for sale, selling, and/or importing the Accused PD Products in the United States, including within this District, that infringe at least claims 40, 45, 49, 50, and 64 of the '825 Patent without the authority of Chrimar.

52. The Accused PD Products are powered-off BaseT Ethernet devices that are configured to be interrogated for a predetermined response via at least one direct current (DC) signal prior to receiving any of their operating power.

53. For example, each Accused PD Product has pairs of contacts of its Ethernet connector that are used to carry 10BaseT and/or 100BaseTX Ethernet communication signals. Additionally, each Accused PD Product implements Section 33.3.5.1 of the 802.3af standard, or a similar provision of another standard, which defines that a PD is powered off and shall “turn on” when certain conditions are met. For example, the representative Geovision GV-VR360 Network Camera datasheet states:

Power Source

DC 12V / PoE (PoE+, IEEE 802.3at)

https://s3.amazonaws.com/geovision_downloads/Manual/IPCAM/Datasheet/VR/Datasheet_IPCa_mH265VR360.pdf, p. 3.

54. The IEEE 802.3at standard is backwards compatible in all material respects with the IEEE 802.3af standard. Each Accused PD Product complies or is compatible with the portions of the IEEE 802.3af standard that prescribe the presentation of valid detection signatures by drawing different magnitudes of DC current flow in response to at least one electrical condition (e.g., a voltage or current) applied to contacts of an Ethernet connector described in the below excerpts:

33.3.3 PD valid and non-valid detection signatures

A PD shall present a valid detection signature at the PI between Positive V_{Port} and Negative V_{Port} of PD Mode A and between Positive V_{Port} and Negative V_{Port} of PD Mode B as defined in 33.3.1 while it is in a state where it will accept power via the PI, but is not powered via the PI.

A PD shall present a non-valid detection signature at the PI between Positive V_{Port} and Negative V_{Port} of PD Mode A and between Positive V_{Port} and Negative V_{Port} of PD Mode B as defined in 33.3.1 while it is in a state where it will not accept power via the PI.

When a PD becomes powered via the PI, it shall present a non-valid detection signature on the set of pairs from which is it not drawing power.

The valid and non-valid detection signature regions are separated by guardbands. The guardbands for the V-I slope are the ranges 12K Ω to 23.75K Ω and 26.25K Ω to 45K Ω . A PD that presents a signature in a guardband is non-compliant.

V-I slope is the effective resistance calculated from the two voltage/current measurements made during the detection process.

$$V-I \text{ slope} = (V_2 - V_1) / (I_2 - I_1) \quad (33-1)$$

where (V_1, I_1) and (V_2, I_2) are measurements made at the PD PI.

The valid PD detection signature shall have the characteristics of Table 33-8.

Table 33-8— Valid PD detection signature characteristics, measured at PD input connector

Parameter	Conditions	Minimum	Maximum	Unit
V-I Slope (at any 1V or greater chord within the voltage range conditions)	2.7V to 10.1V	23.75	26.25	KΩ
V offset			1.9	V
I offset			10	μA
Input capacitance	2.7V to 10.1 V	0.05	0.12	μF
Input inductance	2.7V to 10.1 V		100	μH

A non-valid detection signature shall have one or both of the characteristics in Table 33-9

Table 33-9— Non-valid PD detection signature characteristics, measured at PD input connector

Parameter	Conditions	Range of values	Unit
V-I Slope	V < 10.1V	Either greater than 45 or less than 12	KΩ
Input Capacitance	V < 10.1V	Greater than 10	μF

IEEE 802.3af standard, Abstract, Table 33-8, and Table 33-9

55. Each Accused PD Product is a BaseT Ethernet device that comprises an Ethernet jack connector. The Ethernet jack connector comprises first and second pairs of contacts (1,2 & 3,6). Each of the first and second pairs are configured to carry BaseT Ethernet communication signals wherein the first pair of contacts consists of a transmit pair of the Ethernet jack connector and wherein the second pair of contacts consists of the receive pair of the Ethernet jack connector.

56. For example, the representative Geovision GV-VR360 Network Camera has an RJ-45 Ethernet connector with four pairs of contacts:

Mechanical	
Temperature Detector	N/A
Power	DC 12V, 1.25A, DC Jack / PoE
Ethernet	10/100 Base-T, RJ-45 Connector
Connectors	Audio 1 in (built-in or external microphone with power supply)
	Digital I/O I/O wires
	Local Storage N/A

https://s3.amazonaws.com/geovision_downloads/Manual/IPCAM/Datasheet/VR/Datasheet_IPCa_mH265VR360.pdf, p. 3.

57. Each Accused PD Product is a BaseT Ethernet device that comprises at least one path. The at least one path is for the purpose of drawing at least one direct current (DC) signal. The at least one path is coupled across at least one of the contacts of the first pair (1,2) and at least one of the contacts of the second pair (3,6) of the Ethernet jack connector.

58. For example, because each of the Accused PD Products comply with the IEEE PoE Standards, each “shall be capable of accepting power on either of two sets of PI conductors (1,2 & 3,6 or 4,5 & 7,8). The two conductor sets are named Mode A and Mode B. In each four-wire connection, the two wires associated with a pair are at the same nominal average voltage. Figure 33–5 in conjunction with Table 33–7 illustrates the two power modes.” IEEE 802.3af standard, p. 49.

Table 33–7—PD pinout

Conductor	Mode A	Mode B
1	Positive V_{Port} , Negative V_{Port}	
2	Positive V_{Port} , Negative V_{Port}	
3	Negative V_{Port} , Positive V_{Port}	
4		Positive V_{Port} , Negative V_{Port}
5		Positive V_{Port} , Negative V_{Port}
6	Negative V_{Port} , Positive V_{Port}	
7		Negative V_{Port} , Positive V_{Port}
8		Negative V_{Port} , Positive V_{Port}

IEEE 802.3af standard, Table 33-7. *See also, e.g.,* 802.3af Standard, p. 30, Figure 33-4 showing examples of PDs (referred to as Powered End Stations with respect to Figure 33-4) having paths

coupled across the contacts of the Ethernet connector to be used for detection and classification. Because each Accused PD Product claims IEEE 802.3af/at compliance or compatibility, each has at least one path coupled across the contacts of the Ethernet connector as shown in the simplified example below.

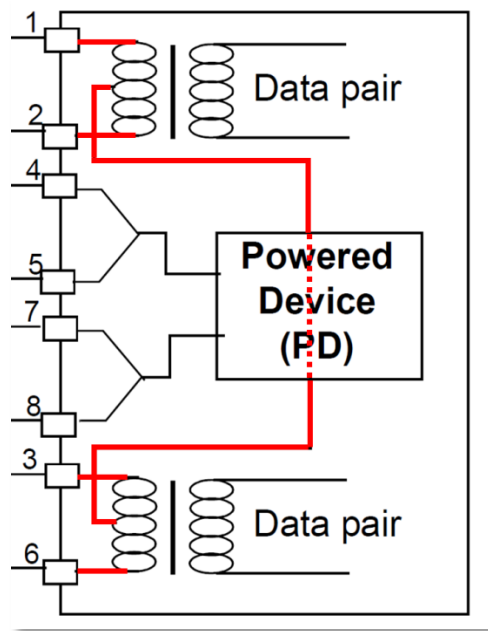

IEEE 802.3af standard, Figure 33-4 (annotated, emphasis added)

59. Each Accused PD Product implements detection and classification protocols requiring at least one path for the purpose of drawing DC current, the at least one path coupled across at least one of the contacts of the first pair of contacts of the Ethernet connector and at least one of the contacts of the second pair of contacts of the Ethernet connector as explained in the 802.3af standard:

33.3.3 PD valid and non-valid detection signatures

A PD shall present a valid detection signature at the PI between Positive V_{Port} and Negative V_{Port} of PD Mode A and between Positive V_{Port} and Negative V_{Port} of PD Mode B as defined in 33.3.1 while it is in a state where it will accept power via the PI, but is not powered via the PI.

A PD shall present a non-valid detection signature at the PI between Positive V_{Port} and Negative V_{Port} of PD Mode A and between Positive V_{Port} and Negative V_{Port} of PD Mode B as defined in 33.3.1 while it is in a state where it will not accept power via the PI.

When a PD becomes powered via the PI, it shall present a non-valid detection signature on the set of pairs from which is it not drawing power.

The valid and non-valid detection signature regions are separated by guardbands. The guardbands for the V-I slope are the ranges 12K Ω to 23.75K Ω and 26.25K Ω to 45K Ω . A PD that presents a signature in a guardband is non-compliant.

V-I slope is the effective resistance calculated from the two voltage/current measurements made during the detection process.

$$\text{V-I slope} = (V_2 - V_1)/(I_2 - I_1) \quad (33-1)$$

where (V_1, I_1) and (V_2, I_2) are measurements made at the PD PI.

The valid PD detection signature shall have the characteristics of Table 33-8.

IEEE 802.3af standard, 33.3.3

60. The Accused PD Products are powered-off BaseT Ethernet devices that are configured to receive or return at least one direct current (DC) signal via at least one of the contacts of the first pair and configured to return or receive the at least one direct current (DC) signal via at least one of the contacts of the second pair of the Ethernet connector prior to receiving any of their operating power. The predetermined response is carried by at least two different magnitudes in the flow of the at least one direct current (DC) signal.

61. For example, the below excerpts of the IEEE PoE Standards demonstrate that a compliant product, such as the Accused PD Products, will draw different magnitudes of DC current flow in response to at least one electrical condition (e.g. voltage or current) applied to a contact, as required to comply with the detection and classification protocols.

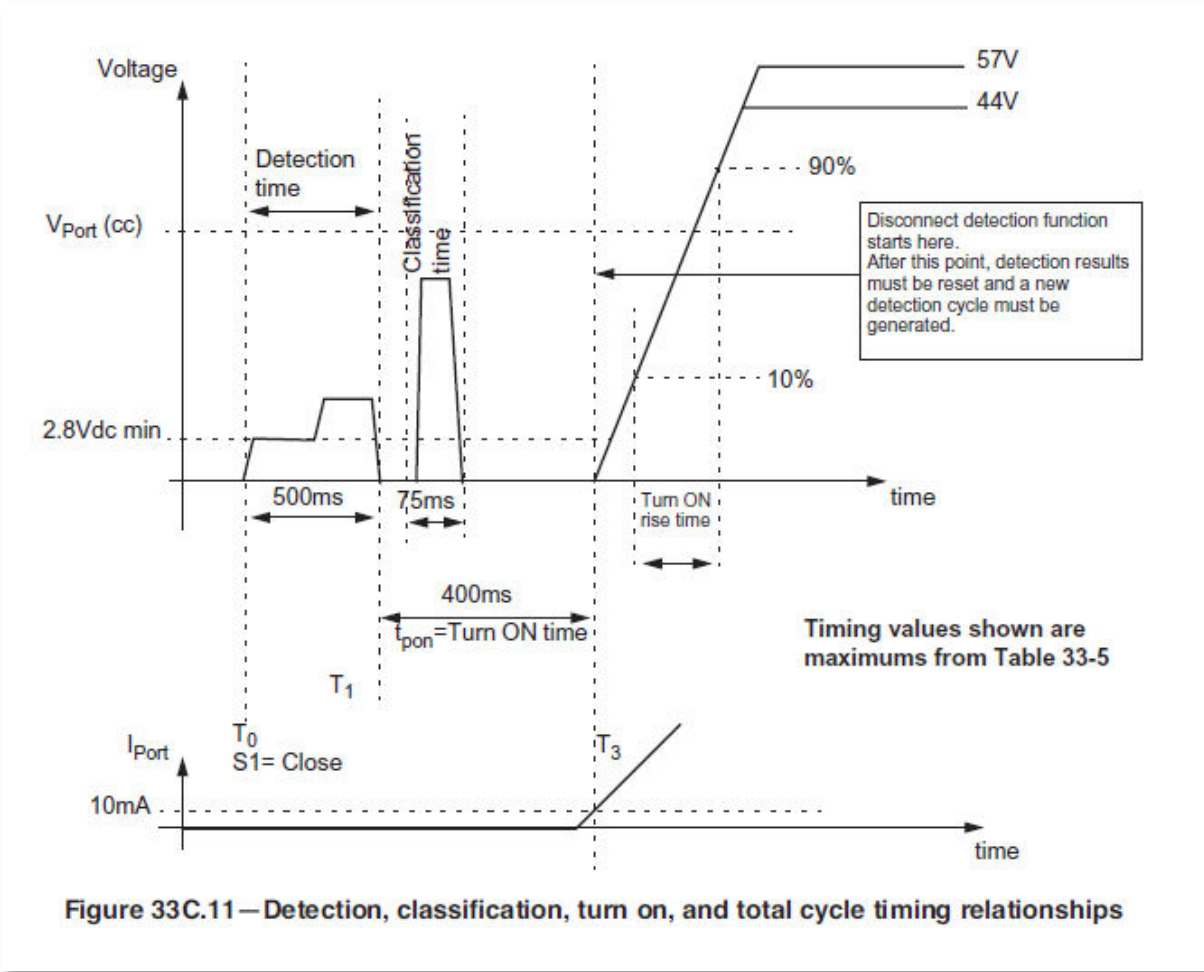

IEEE 802.3af standard, Figure 33C.11 This signature impedance is within the at least one path and distinguishes an Accused PD Product from non-PoE Ethernet devices.

62. Each of the Accused PD Products is a powered-off BaseT Ethernet device wherein the at least one path is physically coupled across at least one of the contacts of the first pair of contacts and at least one of the contacts of the second pair of contacts of the Ethernet jack connector.

63. For example, because each Accused PD Product is IEEE 802.3af/at compliant or compatible, each has at least one path coupled across the contacts of the Ethernet connector as shown in the simplified example below.

33.2 Power sourcing equipment

PSE, as the name implies, is the equipment that provides the power to a single link section. The PSE's main functions are to search the link section for a PD, optionally classify the PD, supply power to the link section (only if a PD is detected), monitor the power on the link section, and scale power back to the detect level when power is no longer requested or required. An unplugged link section is one instance when power is no longer required.

A PSE is electrically specified at the point of the physical connection to the cabling. Characteristics, such as the losses due to overvoltage protection circuits, or power supply inefficiencies, after the PI connector are not accounted for in this specification.

IEEE 802.3af Standard, 33.2.

69. Each Accused PSE Product has an Ethernet jack connector of the BaseT Ethernet device. The Ethernet jack connector comprising first and second pairs of contacts, each of the first and second pairs configured to carry BaseT Ethernet communication signals wherein the first pair of contacts consists of a transmit pair of the Ethernet jack connector and wherein the second pair of contacts consists of a receive pair of the Ethernet jack connector.

70. For example, the representative GV-POE2411 Ethernet Switch is described as having 8 10/100/1000BASE-TX Ethernet/PoE ports used to connect to a PD or non-PoE end device via a data cable employing modular plugs at each end:

2.1 Product Overview



The GV-POE2411 is a 24-port 10/100/1000BaseT(X) PoE+ with 4 Combo SFP Rack-mount Web Smart PoE Switch. The switch supports IEEE 802.3at Power over Ethernet standard, maximum 400 W power consumption, and no special network cable is required for connecting your powered devices (PD), such as IP cameras. The switch also provides exceptionally smart Web management features, such as VLAN, QoS, RSTP, IGMP Snooping, LACP, Port Security, etc. The switch is designed for medium or large network environment to strengthen its network connection and efficiency. It also gives you the option of installing it in a 19" cabinet with a rack-mount kit or underneath a desk.

GV-POE2411 User Manual(POE2411-B-EN).pdf, p. 2.

71. Each Accused Ethernet PSE Product has at least one direct current (DC) supply coupled to at least one of the contacts of the first pair of contacts and at least one of the contacts of the second pair of contacts of the Ethernet jack connector.

72. For example, the representative GV-POE2411 Ethernet Switch's datasheet states that the device has "24 10/100/1000BaseT(X) PoE+ with 4 Combo Uplink Ports." http://pd.geovision.tw/datasheet/POE/Datasheet_POE2411.pdf, p. 1. The ports are further described as "IEEE802.3at compliant (24 Ports at Full 15.4 W)." *Id.* A device that is compliant IEEE 802.3at is backwards compatible with IEEE 802.3af. An IEEE 802.3af compliant Accused PSE Product must also include a DC supply in order to perform detection, classification, and control over the provisioning of a PDs' operating power:

33.2 Power sourcing equipment

PSE, as the name implies, is the equipment that provides the power to a single link section. The PSE's main functions are to search the link section for a PD, optionally classify the PD, supply power to the link section (only if a PD is detected), monitor the power on the link section, and scale power back to the detect level when power is no longer requested or required. An unplugged link section is one instance when power is no longer required.

A PSE is electrically specified at the point of the physical connection to the cabling. Characteristics, such as the losses due to overvoltage protection circuits, or power supply inefficiencies, after the PI connector are not accounted for in this specification.

Table 33-5—PSE output PI electrical requirements for all PD classes, unless otherwise specified

Item	Parameter	Symbol	Unit	Min	Max	Additional information
1	Output voltage	V_{Port}	Vdc	44	57	See 33.2.8.1
2	Load regulation		V	44	57	See 33.2.8.2
3	Power feeding ripple and noise:					
	f < 500Hz		V_{pp}		0.5	See 33.2.8.3
	500Hz to 150kHz		V_{pp}		0.2	
	150KHz to 500KHz		V_{pp}		0.15	
	500KHz to 1MHz		V_{pp}		0.1	
4	Maximum output current in normal powering mode at PSE min output voltage	I_{Port_max}	mAdc	350		See 33.2.8.4

IEEE 802.3af standard, 33.2, Table 33-5.

73. Each Accused PSE Device is configured to provide or receive at least one direct current (DC) signal via at least one of the contacts of the first pair and configured to receive or provide the at least one direct current (DC) signal via at least one of the contacts of the second pair of an Ethernet connector, the predetermined response carried by at least two different magnitudes in the flow of the at least one direct current (DC) signal.

74. For example, each of the Accused PSE products use the magnitude in the flow of the current through the loop to interrogate the piece of BaseT Ethernet terminal equipment. For example, the representative GV-POE2411 Ethernet Switch's datasheet explains:

Introduction

GV-POE2411 is a 24-port 10/100/1000BaseT(X) PoE+ with 4 Combo SFP Rack-mount Web Smart PoE Switch. The switch supports IEEE 802.3at Power over Ethernet standard, maximum 400 W power consumption, and no special network cable is required for connecting your powered devices (PD), such as IP cameras. The switch also provides exceptionally smart Web management features, such as VLAN, QoS, RSTP, IGMP Snooping, LACP, Port Security, etc. The switch is designed for medium or large network environment to strengthen its network connection and efficiency. It also gives you the option of installing it in a 19" cabinet with a rack-mount kit or underneath a desk.

http://pd.geovision.tw/datasheet/POE/Datasheet_POE2411.pdf, p. 1. Devices compliant with IEEE 802.3at, such as the representative product, interrogate the Ethernet data terminal equipment to determine the amount of power (if any) to supply.

75. The Accused PSE Products detect the different magnitudes of DC current flow in response to at least one electrical condition (e.g. voltage or current) applied to contacts of an Ethernet connector, as required to comply with the detection and classification protocols as illustrated here:

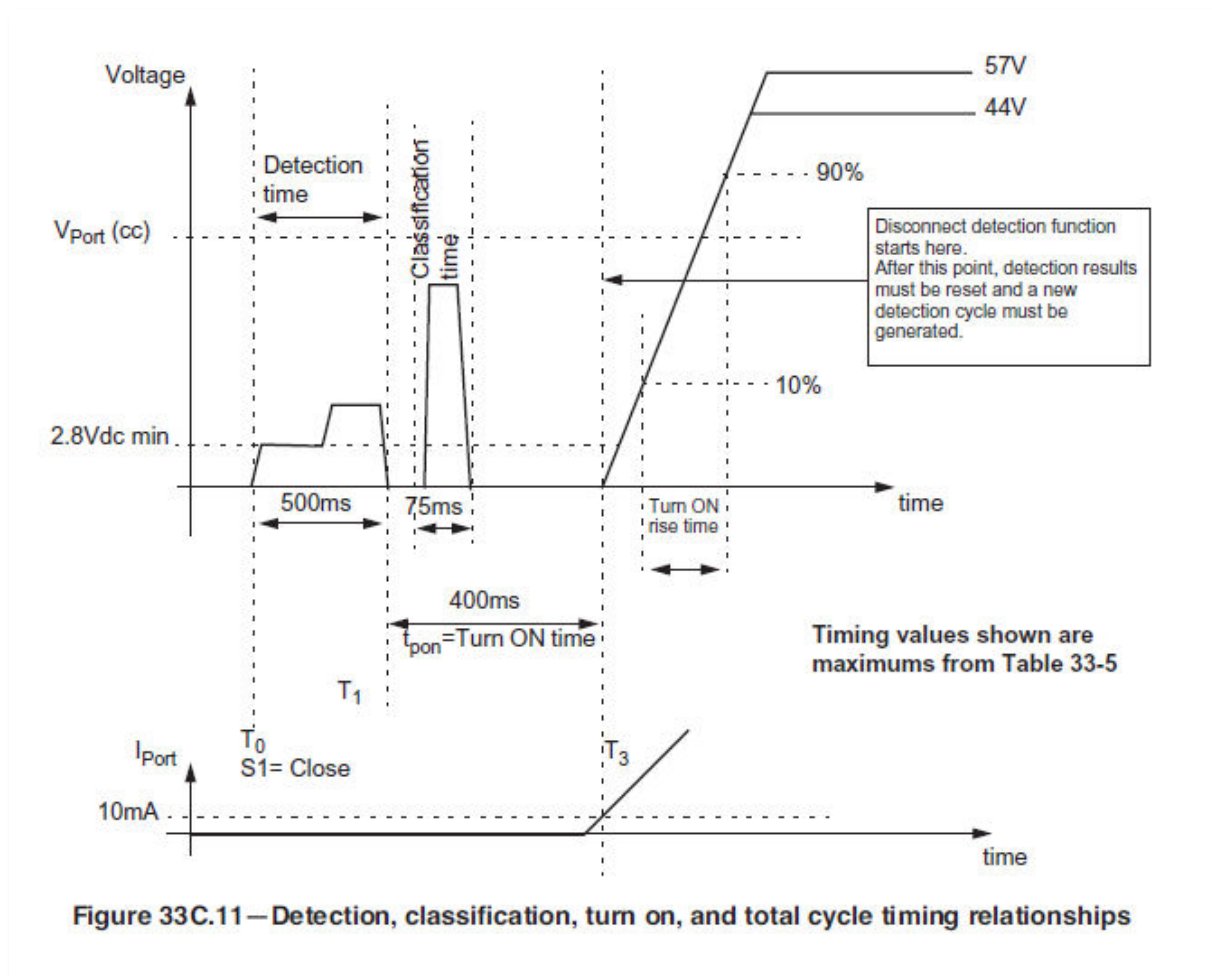

IEEE 802.3af standard, Figure 33C.11 This signature impedance is within the at least one path and distinguishes a PD Ethernet device from a non-PoE (not a PD) Ethernet device.

76. Each of the Accused PSE Products comprise a controller coupled across at least one of the contacts of the first pair of contacts and at least one of the contacts of the second pair of contacts of the Ethernet jack connector.

77. For example, in order for the Accused PSE Products to detect the different magnitudes of DC current flow as described above, the Accused PSE Devices necessarily have a controller coupled to the recited contacts to perform the detection.

78. Upon information and belief, discovery will show that each of the Accused PSE Products has firmware for the controller described in paragraphs 77-78.

79. Accordingly, Defendant has and continues to directly infringe the '825 Patent, both literally and/or under the doctrine of equivalents, in violation of 35 U.S.C. § 271(a) by making, using, offering for sale, selling, and/or importing into the United States the Accused Products without the authority of Chrimar.

80. Defendant has been on notice of the '825 Patent since at least the filing of this Complaint. *See Script Sec. Sols. L.L.C. v. Amazon.com, Inc.*, 170 F. Supp. 3d 928, 937 (E.D. Tex. 2016).

81. In violation of 35 U.S.C. § 271(b), Defendant has indirectly infringed the '825 Patent by inducing its customers to directly infringe the '825 Patent, both literally and/or under the doctrine of equivalents, at least by providing its customers with instructions on using the Accused Products and by making, using, offering for sale, selling, and/or importing devices in the United States the Accused Products without the authority of Chrimar. For example, the representative GV-POE2411 Ethernet Switch's User Manual instructs:

2.1 Product Overview



The GV-POE2411 is a 24-port 10/100/1000BaseT(X) PoE+ with 4 Combo SFP Rack-mount Web Smart PoE Switch. The switch supports IEEE 802.3at Power over Ethernet standard, maximum 400 W power consumption, and no special network cable is required for connecting your powered devices (PD), such as IP cameras. The switch also provides exceptionally smart Web management features, such as VLAN, QoS, RSTP, IGMP Snooping, LACP, Port Security, etc. The switch is designed for medium or large network environment to strengthen its network connection and efficiency. It also gives you the option of installing it in a 19" cabinet with a rack-mount kit or underneath a desk.

GV-POE2411 User Manual(POE2411-B-EN).pdf, p. 2.

82. Upon information and belief, and in violation of 35 U.S.C. § 271(b), Defendant has indirectly infringed the `825 Patent by contribution knowing that the Accused Products would be combined with other components to infringe the `825 Patent and that the Accused Products have no substantial non-infringing use.

83. Unless enjoined by this Court, Defendant will continue to infringe the `825 Patent.

84. Because of Defendant's infringing activities, Chrimar has suffered damages and will continue to suffer damages in the future.

COUNT III **INFRINGEMENT OF U.S. PATENT NO. 8,902,760**

85. Chrimar alleges and hereby incorporates by reference every allegation made in the foregoing paragraphs of this Complaint as if each were separately set forth herein.

86. In violation of 35 U.S.C. § 271, Defendant has directly infringed and continue to directly infringe, both literally and/or under the doctrine of equivalents, the `760 Patent by making, using, offering for sale, selling, and/or importing the Accused Products in the United States,

including within this District, that infringe at least claims 166, 177, and claim 219 across claims 158, 179, 180 and 182 of the '760 Patent without the authority of Chrimar.

87. The identified claims of the '760 Patent are presumed valid.

88. Each of the Accused PD Products is a piece of BaseT Ethernet terminal equipment. For example, the representative Geovision GV-VR360 Network Camera is a piece of BaseT Ethernet terminal equipment.

Mechanical		
Temperature Detector		N/A
	Power	DC 12V, 1.25A, DC Jack / PoE
	Ethernet	10/100 Base-T, RJ-45 Connector
Connectors	Audio	1 in (built-in or external microphone with power supply)
	Digital I/O	I/O wires
	Local Storage	N/A

https://s3.amazonaws.com/geovision_downloads/Manual/IPCAM/Datasheet/VR/Datasheet_IPCAMH265VR360.pdf, p. 3.

89. Each of the Accused PSE Products is a piece of central network equipment. For example, the representative GV-POE2411 Ethernet Switch is a piece of central network equipment.

2.1 Product Overview



The GV-POE2411 is a 24-port 10/100/1000BaseT(X) PoE+ with 4 Combo SFP Rack-mount Web Smart PoE Switch. The switch supports IEEE 802.3at Power over Ethernet standard, maximum 400 W power consumption, and no special network cable is required for connecting your powered devices (PD), such as IP cameras. The switch also provides exceptionally smart Web management features, such as VLAN, QoS, RSTP, IGMP Snooping, LACP, Port Security, etc. The switch is designed for medium or large network environment to strengthen its network connection and efficiency. It also gives you the option of installing it in a 19" cabinet with a rack-mount kit or underneath a desk.

GV-POE2411 User Manual(POE2411-B-EN).pdf, p. 2.

90. The Accused Products comprise a BaseT Ethernet system where Ethernet cabling can physically connect a piece of BaseT Ethernet terminal equipment to a piece of central network equipment. For example, the Geovision GV-VR360 Network Camera can be physically connected to the representative GV-POE2411 Ethernet Switch with an Ethernet cable.

Mechanical		
Temperature Detector		N/A
	Power	DC 12V, 1.25A, DC Jack / PoE
	Ethernet	10/100 Base-T, RJ-45 Connector
Connectors	Audio	1 in (built-in or external microphone with power supply)
	Digital I/O	I/O wires
	Local Storage	N/A

https://s3.amazonaws.com/geovision_downloads/Manual/IPCAM/Datasheet/VR/Datasheet_IPCa_mH265VR360.pdf, p. 3.

GV-PoE Switch	GV-PoE Switch is designed to provide power along with network connection for IP devices. GV-PoE Switch is available in various models with different numbers and types of ports.
---------------	--

GV-VR360_User_Manual(VR360V101-UM-A), p. 2 and:

2.1 Product Overview



The GV-POE2411 is a 24-port 10/100/1000BaseT(X) PoE+ with 4 Combo SFP Rack-mount Web Smart PoE Switch. The switch supports IEEE 802.3at Power over Ethernet standard, maximum 400 W power consumption, and no special network cable is required for connecting your powered devices (PD), such as IP cameras. The switch also provides exceptionally smart Web management features, such as VLAN, QoS, RSTP, IGMP Snooping, LACP, Port Security, etc. The switch is designed for medium or large network environment to strengthen its network connection and efficiency. It also gives you the option of installing it in a 19" cabinet with a rack-mount kit or underneath a desk.

GV-POE2411 User Manual(POE2411-B-EN).pdf, p. 2.

91. The Ethernet cabling has at least first and second pairs of conductors used to carry BaseT Ethernet communication signals, and the first and second pairs of conductors can physically connect between a piece of BaseT Ethernet terminal equipment and a piece of central network equipment:

2.1 Product Overview



The GV-POE2411 is a 24-port 10/100/1000BaseT(X) PoE+ with 4 Combo SFP Rack-mount Web Smart PoE Switch. The switch supports IEEE 802.3at Power over Ethernet standard, maximum 400 W power consumption, and no special network cable is required for connecting your powered devices (PD), such as IP cameras. The switch also provides exceptionally smart Web management features, such as VLAN, QoS, RSTP, IGMP Snooping, LACP, Port Security, etc. The switch is designed for medium or large network environment to strengthen its network connection and efficiency. It also gives you the option of installing it in a 19" cabinet with a rack-mount kit or underneath a desk.

GV-POE2411 User Manual(POE2411-B-EN).pdf, p. 2.

92. Each of the Accused PSE Products has at least one DC supply to provide at least one DC condition (e.g., voltage or current) across at least one of the conductors of the first pair of contacts and at least one of the contacts of the second pairs of contacts of an Ethernet connector. For example, the representative GV-POE2411 Ethernet Switch claims compliance with the IEEE 802.3at standard:

Interface

- Number of Ports: 24
 - 24-port 10/100/1000BaseT(X) with RJ-45 Connectors, PoE+
 - 4-port Gigabit SFP Combo Uplink Port

GV-POE2411 User Manual(POE2411-B-EN).pdf, p. 2.

93. A device that is compliant IEEE 802.3at is backwards compatible with IEEE 802.3af. An IEEE 802.3af compliant Accused PSE Product must also include a DC supply in order to perform detection, classification, and control over the provisioning of a PDs operating power:

33.2 Power sourcing equipment

PSE, as the name implies, is the equipment that provides the power to a single link section. The PSE’s main functions are to search the link section for a PD, optionally classify the PD, supply power to the link section (only if a PD is detected), monitor the power on the link section, and scale power back to the detect level when power is no longer requested or required. An unplugged link section is one instance when power is no longer required.

A PSE is electrically specified at the point of the physical connection to the cabling. Characteristics, such as the losses due to overvoltage protection circuits, or power supply inefficiencies, after the PI connector are not accounted for in this specification.

Table 33-5—PSE output PI electrical requirements for all PD classes, unless otherwise specified

Item	Parameter	Symbol	Unit	Min	Max	Additional information
1	Output voltage	V_{Port}	Vdc	44	57	See 33.2.8.1
2	Load regulation		V	44	57	See 33.2.8.2
3	Power feeding ripple and noise:					
	f < 500Hz		V_{pp}		0.5	See 33.2.8.3
	500Hz to 150kHz		V_{pp}		0.2	
	150KHz to 500KHz		V_{pp}		0.15	
500KHz to 1MHz		V_{pp}		0.1		
4	Maximum output current in normal powering mode at PSE min output voltage	I_{Port_max}	mAdc	350		See 33.2.8.4

IEEE 802.3af standard, 33.2, Table 33-5

94. Each of the Accused PD Products has at least one path to change impedance within a loop formed via at least one of the contacts of the first pair of contacts and the at least one of the contacts of the second pair of contacts of the Ethernet connector by changing impedance within the at least one path in response to the at least one DC condition (e.g., voltage or current) across

the at least one path. For example, the representative Geovision GV-VR360 Network Camera claims compliance with the IEEE 802.3at standard:

Power Source	DC 12V / PoE (PoE+, IEEE 802.3at)
--------------	-----------------------------------

https://s3.amazonaws.com/geovision_downloads/Manual/IPCAM/Datasheet/VR/Datasheet_IPCamH265VR360.pdf, p. 3.

95. The IEEE 802.3at standard is backwards compatible in all material respects with the IEEE 802.3af standard. IEEE 802.3af explains:

33.3.3 PD valid and non-valid detection signatures

A PD shall present a valid detection signature at the PI between Positive V_{Port} and Negative V_{Port} of PD Mode A and between Positive V_{Port} and Negative V_{Port} of PD Mode B as defined in 33.3.1 while it is in a state where it will accept power via the PI, but is not powered via the PI.

A PD shall present a non-valid detection signature at the PI between Positive V_{Port} and Negative V_{Port} of PD Mode A and between Positive V_{Port} and Negative V_{Port} of PD Mode B as defined in 33.3.1 while it is in a state where it will not accept power via the PI.

When a PD becomes powered via the PI, it shall present a non-valid detection signature on the set of pairs from which is it not drawing power.

The valid and non-valid detection signature regions are separated by guardbands. The guardbands for the V-I slope are the ranges 12K Ω to 23.75K Ω and 26.25K Ω to 45K Ω . A PD that presents a signature in a guardband is non-compliant.

V-I slope is the effective resistance calculated from the two voltage/current measurements made during the detection process.

$$V-I \text{ slope} = (V_2 - V_1) / (I_2 - I_1) \quad (33-1)$$

where (V_1, I_1) and (V_2, I_2) are measurements made at the PD PI.

The valid PD detection signature shall have the characteristics of Table 33-8.

IEEE 802.3af standard, 33.3.3

96. Upon information and belief, discovery will show that the at least one path is integrated into each of the Accused PD Products.

97. Each of the Accused PD Products is a powered-off end device prior to receiving any of its operating power. For example, the representative Geovision GV-VR360 Network

Camera is a powered-off Ethernet end device when requesting power or when it is not connected to the network.

98. Each of the Accused PSE Products can detect at least one impedance condition within the loop with the piece of BaseT Ethernet terminal equipment powered-off. For example, the representative Geovision GV-VR360 Network Camera claims compliance with the IEEE 802.3at standard. *See* https://s3.amazonaws.com/geovision_downloads/Manual/IPCAM/Datasheet/VR/Datasheet_IPCa_mH265VR360.pdf, p. 3.

99. The IEEE 802.3at standard is backwards compatible in all material respects with the IEEE 802.3af standard. IEEE 802.3af explains:

33.2.4 PD detection

In an operational mode, the PSE shall not apply operating power to the PI until the PSE has successfully detected a PD requesting power.

IEEE 802.3af standard, 33.2.4

100. Each of the Accused PSE Products has an integrated DC power source. For example, the representative GV-POE2411 Ethernet Switch's User Manual explains:

2.1 Product Overview



The GV-POE2411 is a 24-port 10/100/1000BaseT(X) PoE+ with 4 Combo SFP Rack-mount Web Smart PoE Switch. The switch supports IEEE 802.3at Power over Ethernet standard, maximum 400 W power consumption, and no special network cable is required for connecting your powered devices (PD), such as IP cameras. The switch also provides exceptionally smart Web management features, such as VLAN, QoS, RSTP, IGMP Snooping, LACP, Port Security, etc. The switch is designed for medium or large network environment to strengthen its network connection and efficiency. It also gives you the option of installing it in a 19" cabinet with a rack-mount kit or underneath a desk.

GV-POE2411 User Manual(POE2411-B-EN).pdf, p. 2.

101. Each of the Accused PSE Products uses the magnitude in the flow of current through the loop to interrogate the piece of BaseT Ethernet terminal Equipment. For example, the representative GV-POE2411 Ethernet Switch's User Manual explains:

2.1 Product Overview



The GV-POE2411 is a 24-port 10/100/1000BaseT(X) PoE+ with 4 Combo SFP Rack-mount Web Smart PoE Switch. The switch supports IEEE 802.3at Power over Ethernet standard, maximum 400 W power consumption, and no special network cable is required for connecting your powered devices (PD), such as IP cameras. The switch also provides exceptionally smart Web management features, such as VLAN, QoS, RSTP, IGMP Snooping, LACP, Port Security, etc. The switch is designed for medium or large network environment to strengthen its network connection and efficiency. It also gives you the option of installing it in a 19" cabinet with a rack-mount kit or underneath a desk.

GV-POE2411 User Manual(POE2411-B-EN).pdf, p. 2.

102. Each of the Accused PD Products relates information about itself to at least one impedance condition within the at least one path. For example, each of the Accused PD Products relates its power class to an impedance signature within at least one path during classification and conveys that information via different magnitudes of DC current in response to an electrical condition (e.g., voltage or current) applied to at least one of the contacts of its Ethernet connector. The Geovision GV-VR360 Network Camera, for example, claims compliance with the IEEE 802.3at standard. *See* https://s3.amazonaws.com/geovision_downloads/Manual/IPCAM/Datasheet/VR/Datasheet_IPCa_mH265VR360.pdf, p. 3. The IEEE 802.3at standard is backwards compatible in all material respects with the IEEE 802.3af standard. IEEE 802.3af explains:

33.3.3 PD valid and non-valid detection signatures

A PD shall present a valid detection signature at the PI between Positive V_{Port} and Negative V_{Port} of PD Mode A and between Positive V_{Port} and Negative V_{Port} of PD Mode B as defined in 33.3.1 while it is in a state where it will accept power via the PI, but is not powered via the PI.

A PD shall present a non-valid detection signature at the PI between Positive V_{Port} and Negative V_{Port} of PD Mode A and between Positive V_{Port} and Negative V_{Port} of PD Mode B as defined in 33.3.1 while it is in a state where it will not accept power via the PI.

When a PD becomes powered via the PI, it shall present a non-valid detection signature on the set of pairs from which is it not drawing power.

The valid and non-valid detection signature regions are separated by guardbands. The guardbands for the V-I slope are the ranges 12K Ω to 23.75K Ω and 26.25K Ω to 45K Ω . A PD that presents a signature in a guardband is non-compliant.

V-I slope is the effective resistance calculated from the two voltage/current measurements made during the detection process.

$$V-I \text{ slope} = (V_2 - V_1) / (I_2 - I_1) \quad (33-1)$$

where (V_1, I_1) and (V_2, I_2) are measurements made at the PD PI.

The valid PD detection signature shall have the characteristics of Table 33-8.

IEEE 802.3af standard, 33.3.3

103. The information can generally be used, for example, to distinguish a piece of Ethernet terminal equipment e.g., a PD like the Accused PD Products from a piece of Ethernet terminal equipment that is not a PD, and/or to identify each Accused PD Product's power requirements or class.

104. Accordingly, Defendant has and continues to directly infringe the '760 Patent, both literally and/or under the doctrine of equivalents, in violation of 35 U.S.C. § 271(a) by making, using, offering for sale, selling, and/or importing into the United States the Accused Products without the authority of Chrimar.

105. Defendant has been on notice of the '760 Patent since at least filing of this Complaint. *See Script Sec. Sols. L.L.C. v. Amazon.com, Inc.*, 170 F. Supp. 3d 928, 937 (E.D. Tex. 2016).

106. In violation of 35 U.S.C. § 271(b), Defendant has indirectly infringed the `760 Patent by inducing its customers to directly infringe the `760 Patent, both literally and/or under the doctrine of equivalents, at least by providing its customers with instructions on using the Accused Products and by making, using, offering for sale, selling, and/or importing devices in the United States the Accused Products without the authority of Chrimar. For example, the representative GV-POE2411 Ethernet Switch's User Manual instructs:

2.1 Product Overview



The GV-POE2411 is a 24-port 10/100/1000BaseT(X) PoE+ with 4 Combo SFP Rack-mount Web Smart PoE Switch. The switch supports IEEE 802.3at Power over Ethernet standard, maximum 400 W power consumption, and no special network cable is required for connecting your powered devices (PD), such as IP cameras. The switch also provides exceptionally smart Web management features, such as VLAN, QoS, RSTP, IGMP Snooping, LACP, Port Security, etc. The switch is designed for medium or large network environment to strengthen its network connection and efficiency. It also gives you the option of installing it in a 19" cabinet with a rack-mount kit or underneath a desk.

GV-POE2411 User Manual(POE2411-B-EN).pdf, p. 2.

107. Upon information and belief, and in violation of 35 U.S.C. § 271(b), Defendant has indirectly infringed the `760 Patent by contribution knowing that the Accused Products would be combined with other components to infringe the `760 Patent and that the Accused Products have no substantial non-infringing use.

108. Unless enjoined by this Court, Defendant will continue to infringe the `760 Patent.

109. Because of Defendant's infringing activities, Chrimar has suffered damages and will continue to suffer damages in the future.

COUNT IV
INFRINGEMENT OF U.S. PATENT NO. 9,019,838

110. Chrimar alleges and hereby incorporates by reference every allegation made in the foregoing paragraphs of this Complaint as if each were separately set forth herein.

111. In violation of 35 U.S.C. § 271, Defendant has directly infringed and continues to directly infringe, both literally and/or under the doctrine of equivalents, the '838 Patent by making, using, offering for sale, selling, and/or importing the Accused PSE Products in the United States, including within this District, that infringe at least claims 6, 37, 76, and 87 of the '838 Patent without the authority of Chrimar.

112. The identified claims of the '838 Patent are presumed valid.

113. Each of the Accused PSE Products is a piece of central network equipment. For example, the representative GV-POE2411 Ethernet Switch is a piece of central network equipment.

2.1 Product Overview



The GV-POE2411 is a 24-port 10/100/1000BaseT(X) PoE+ with 4 Combo SFP Rack-mount Web Smart PoE Switch. The switch supports IEEE 802.3at Power over Ethernet standard, maximum 400 W power consumption, and no special network cable is required for connecting your powered devices (PD), such as IP cameras. The switch also provides exceptionally smart Web management features, such as VLAN, QoS, RSTP, IGMP Snooping, LACP, Port Security, etc. The switch is designed for medium or large network environment to strengthen its network connection and efficiency. It also gives you the option of installing it in a 19" cabinet with a rack-mount kit or underneath a desk.

GV-POE2411 User Manual(POE2411-B-EN).pdf, p. 2.

114. Each of the Accused PSE Products is an Ethernet device. For example, the representative GV-POE2411 Ethernet Switch is a central piece of Ethernet equipment:

2.1 Product Overview



The GV-POE2411 is a 24-port 10/100/1000BaseT(X) PoE+ with 4 Combo SFP Rack-mount Web Smart PoE Switch. The switch supports IEEE 802.3at Power over Ethernet standard, maximum 400 W power consumption, and no special network cable is required for connecting your powered devices (PD), such as IP cameras. The switch also provides exceptionally smart Web management features, such as VLAN, QoS, RSTP, IGMP Snooping, LACP, Port Security, etc. The switch is designed for medium or large network environment to strengthen its network connection and efficiency. It also gives you the option of installing it in a 19" cabinet with a rack-mount kit or underneath a desk.

GV-POE2411 User Manual(POE2411-B-EN).pdf, p. 2.

115. Each of the Accused PSE Products has at least one Ethernet connector comprising first and second pairs of contacts used to carry BaseT Ethernet communication signals. For example, the representative GV-POE2411 Ethernet Switch has at least one RJ-45 Ethernet connector comprising first and second pairs of contacts and is used to carry 10BaseT, 100BaseTX, and 1000BaseT Ethernet communication signals:

Introduction

GV-POE2411 is a 24-port 10/100/1000BaseT(X) PoE+ with 4 Combo SFP Rack-mount Web Smart PoE Switch. The switch supports IEEE 802.3at Power over Ethernet standard, maximum 400 W power consumption, and no special network cable is required for connecting your powered devices (PD), such as IP cameras. The switch also provides exceptionally smart Web management features, such as VLAN, QoS, RSTP, IGMP Snooping, LACP, Port Security, etc. The switch is designed for medium or large network environment to strengthen its network connection and efficiency. It also gives you the option of installing it in a 19" cabinet with a rack-mount kit or underneath a desk.

http://pd.geovision.tw/datasheet/POE/Datasheet_POE2411.pdf, p. 1.

116. Each of the Accused PSE Products is configured to detect different magnitudes of DC current flow via at least one of the contacts of the first and second pairs of contacts of its Ethernet connector and configured to control application of at least one electrical condition (e.g., voltage or current) to at least one of the contacts of the first and second pairs of contacts of an Ethernet connector in response to at least one of the magnitudes of the DC current flow. For

example, the representative GV-POE2411 Ethernet Switch claims compliance with the IEEE 802.3at standard:

Introduction

GV-POE2411 is a 24-port 10/100/1000BaseT(X) PoE+ with 4 Combo SFP Rack-mount Web Smart PoE Switch. The switch supports IEEE 802.3at Power over Ethernet standard, maximum 400 W power consumption, and no special network cable is required for connecting your powered devices (PD), such as IP cameras. The switch also provides exceptionally smart Web management features, such as VLAN, QoS, RSTP, IGMP Snooping, LACP, Port Security, etc. The switch is designed for medium or large network environment to strengthen its network connection and efficiency. It also gives you the option of installing it in a 19" cabinet with a rack-mount kit or underneath a desk.

http://pd.geovision.tw/datasheet/POE/Datasheet_POE2411.pdf, p. 1.

117. A device that is compliant IEEE 802.3at is backwards compatible with IEEE 802.3af. The IEEE 802.3af standard describes detecting different magnitudes of current flow that occur as part of the detection and classification protocols:

33.2.4 PD detection

In an operational mode, the PSE shall not apply operating power to the PI until the PSE has successfully detected a PD requesting power.

33.2.5.1 Detection probe requirements

The detection voltage V_{detect} shall be within the V_{valid} voltage range at the PSE PI as specified in Table 33–2 with a valid PD detection signature connected. The PSE shall make at least two measurements with V_{detect} values that create at least a ΔV_{test} difference as specified in Table 33–2 between the two measurements with a valid PD detection signature connected.

NOTE—Settling time before voltage or current measurement: the voltage or current measurement should be taken after V_{detect} has settled to within 1% of its steady state condition.

The PSE shall control the slew rate of the probing detection voltage when switching between detection voltages to be less than V_{slew} as specified in Table 33–2.

The polarity of V_{detect} shall match the polarity of V_{Port} as defined in 33.2.1.

IEEE 802.3af standard, 33.2.4, 33.2.5.1

118. Each of the Accused PSE Products is configured to provide at least one DC current via at least one of the contacts of the first and second pairs of contacts of its Ethernet connector

and configured to detect identifying information within the DC current via the at least one of the contacts of the first and second pairs of contacts of its Ethernet connector. For example, the representative GV-POE2411 Ethernet Switch claims compliance with the IEEE 802.3at standard. See http://pd.geovision.tw/datasheet/POE/Datasheet_POE2411.pdf, p. 1. A device that is IEEE 802.3at compliant is backwards compatible with IEEE 802.3af. The IEEE 802.3af standard explains, for example:

33.2.5 PSE validation circuit

The PSE shall detect the PD by probing via the PSE PI. The Thevenin equivalent of the detection circuit is shown in Figure 33–8. PSE requirements are stated for a Thevenin circuit only; they may be transformed via circuit theory into other circuit parameters in specific implementations.

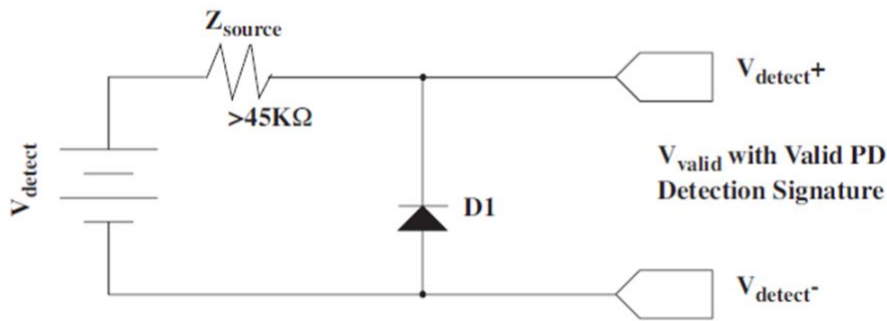

Figure 33–8—PSE detection source

33.2.7.1 Classification power levels

PDs provide information that allow a PSE to classify their power requirements. The classifications are listed in Table 33–3.

Class 4 is reserved for future use. PDs classified as Class 4 shall be treated as Class 0 for powering purposes.

IEEE 802.3af standard, 33.2.5, Figure 33-8, and 33.2.7.1

119. The detection and classification protocols employ different magnitudes of current flow via specific contacts of an Ethernet connector:

33.2.2 PI pin assignments

A PSE device may provide power via one of two valid four-wire connections. In each four-wire connection, the two conductors associated with a pair each carry the same nominal current in both magnitude and polarity. Figure 33–5, in conjunction with Table 33–1, illustrates the valid alternatives.

Table 33–1 – PSE pinout alternatives

Conductor	Alternative A (MDI-X)	Alternative A (MDI)	Alternative B (All)
1	Negative V_{Port}	Positive V_{Port}	
2	Negative V_{Port}	Positive V_{Port}	
3	Positive V_{Port}	Negative V_{Port}	
4			Positive V_{Port}
5			Positive V_{Port}
6	Positive V_{Port}	Negative V_{Port}	
7			Negative V_{Port}
8			Negative V_{Port}

IEEE 802.3af standard, 33.2.2, Figure 33-1

120. Accordingly, Defendant has and continues to directly infringe the '838 Patent, both literally and/or under the doctrine of equivalents, in violation of 35 U.S.C. § 271(a) by making, using, offering for sale, selling, and/or importing into the United States the Accused Products without the authority of Chrimar.

121. Defendant has been on notice of the '838 Patent since at least filing of this Complaint. *See Script Sec. Sols. L.L.C. v. Amazon.com, Inc.*, 170 F. Supp. 3d 928, 937 (E.D. Tex. 2016).

122. In violation of 35 U.S.C. § 271(b), Defendant has indirectly infringed the '838 Patent by inducing its customers to directly infringe the '838 Patent, both literally and/or under the doctrine of equivalents, at least by providing its customers with instructions on using the

Accused Products and by making, using, offering for sale, selling, and/or importing devices in the United States the Accused Products without the authority of Chrimar. For example, the representative GV-POE2411 Ethernet Switch's User Manual instructs:

2.1 Product Overview



The GV-POE2411 is a 24-port 10/100/1000BaseT(X) PoE+ with 4 Combo SFP Rack-mount Web Smart PoE Switch. The switch supports IEEE 802.3at Power over Ethernet standard, maximum 400 W power consumption, and no special network cable is required for connecting your powered devices (PD), such as IP cameras. The switch also provides exceptionally smart Web management features, such as VLAN, QoS, RSTP, IGMP Snooping, LACP, Port Security, etc. The switch is designed for medium or large network environment to strengthen its network connection and efficiency. It also gives you the option of installing it in a 19" cabinet with a rack-mount kit or underneath a desk.

GV-POE2411 User Manual(POE2411-B-EN).pdf, p. 2.

123. Upon information and belief, and in violation of 35 U.S.C. § 271(b), Defendant has indirectly infringed the '838 Patent by contribution knowing that the Accused Products would be combined with other components to infringe the '838 Patent and that the Accused Products have no substantial non-infringing use.

124. Unless enjoined by this Court, Defendant will continue to infringe the '838 Patent.

125. Because of Defendant's infringing activities, Chrimar has suffered damages and will continue to suffer damages in the future.

APPLICATION FOR PRELIMINARY AND PERMANENT INJUNCTION

126. Chrimar alleges and hereby incorporates by reference each and every of the allegations made in the foregoing paragraphs of this Complaint as if each were separately set forth herein.

127. As discussed above, Chrimar was the first company to employ DC current within a BaseT network in the early 1990s and has received a number of US patents for this very important technology, and continues to market its products including the EtherLock® II and ELID products. See http://cmstech.com/security_solutions/products/products.html. Chrimar's EtherLock® II product practices certain claims of the '838 Patent, and the installed ELID/NIC-Stick circuitry practice certain claims of the '107, '760, and '825 Patents. See also <http://www.cmspatents.com/>.

128. Upon information and belief, Defendant, unless enjoined, will continue to infringe Chrimar's intellectual property rights in the '107, '825, '760, and '838 Patents as described in this Complaint.

129. These actions entitle Chrimar to a preliminary injunction and, upon hearing, permanent injunction enjoining Defendant and its officers, agents, servants, employees, users, and attorneys, and all those persons in active concert or in participation with them from:

- (i) Making, using, offering to sell, or selling any product that infringes the '107, '825, '760, and '838 Patents, including the Accused Products and all other similar infringing products; and
- (ii) Otherwise infringing any rights of Chrimar.

130. For these actions, there is no adequate remedy at law. The Patents-in-Suit cover the core technology of Chrimar's and Defendant's businesses. Defendant's efficient infringement gives them an unfair advantage in the marketplace by allowing Defendant to make infringing alternatives available to the marketplace. In view of this, the injury to Chrimar greatly outweighs any injury to Defendant that the requested injunction may cause, and the balance of hardships tips strongly in favor of Chrimar.

131. Further, Chrimar is substantially likely to prevail on the merits of these claims. For example, in *Chrimar Systems, Inc., et al., v. Alcatel-Lucent Enterprise, USA, Inc.*, Alcatel-Lucent stipulated to infringement of certain claims of the '107, '760, and '838 Patents and the jury rejected

Alcatel-Lucent's validity challenge to the '107, '760, and '838 Patent's claims asserted in that case. Civil Action No. 6:15-cv-163-JDL, Dkt No. 349 (Verdict Form, Oct. 10, 2016), Dkt No. 423 (Final Judgment, February 2, 2017) (E.D. Tex.).

132. Finally, the injunction will not disserve the public interest. Here, the public interest favors entry of a permanent injunction because the detrimental effect of inhibiting innovation, coupled with the public's general interest in the judicial protection of property rights in inventive technology, outweighs any interest the public has in purchasing cheaper infringing products.

133. Therefore, Chrimar is entitled to preliminary and permanent injunctive relief against Defendant.

ADDITIONAL ALLEGATIONS

134. Chrimar has complied with 35 U.S.C. § 287.

NOTICE OF REQUIREMENT OF LITIGATION HOLD

135. Defendant is hereby notified they are legally obligated to locate, preserve, and maintain all records, notes, drawings, documents, data, communications, materials, electronic recordings, audio/video/photographic recordings, and digital files, including edited and unedited or "raw" source material, and other information and tangible things that Defendant knows, or reasonably should know, may be relevant to actual or potential claims, counterclaims, defenses, and/or damages by any party or potential party in this lawsuit, whether created or residing in hard copy form or in the form of electronically stored information (hereafter collectively referred to as "Potential Evidence").

136. As used above, the phrase "electronically stored information" includes without limitation: computer files (and file fragments), e-mail (both sent and received, whether internally or externally), information concerning e-mail (including but not limited to logs of e-mail history

and usage, header information, and deleted but recoverable emails), text files (including drafts, revisions, and active or deleted word processing documents), instant messages, audio recordings and files, video footage and files, audio files, photographic footage and files, spreadsheets, databases, calendars, telephone logs, contact manager information, internet usage files, and all other information created, received, or maintained on any and all electronic and/or digital forms, sources and media, including, without limitation, any and all hard disks, removable media, peripheral computer or electronic storage devices, laptop computers, mobile phones, personal data assistant devices, Blackberry devices, iPhones, video cameras and still cameras, and any and all other locations where electronic data is stored. These sources may also include any personal electronic, digital, and storage devices of any and all of Defendant's agents, resellers, or employees if Defendant's electronically stored information resides there.

137. Defendant is hereby further notified and forewarned that any alteration, destruction, negligent loss, or unavailability, by act or omission, of any Potential Evidence may result in damages or a legal presumption by the Court and/or jury that the Potential Evidence is not favorable to Defendant's claims and/or defenses. To avoid such a result, Defendant's preservation duties include, but are not limited to, the requirement that Defendant immediately notify its agents and employees to halt and/or supervise the autodelete functions of Defendant's electronic systems and refrain from deleting Potential Evidence, either manually or through a policy of periodic deletion.

JURY DEMAND

Pursuant to Rule 38 of the Federal Rules of Civil Procedure, Chrimar demands a trial by jury on all issues triable as such.

PRAYER FOR RELIEF

Chrimar requests that this Court find in its favor and against Defendant, and that this Court grant Chrimar the following relief:

- A. An adjudication that Defendant has infringed the `107, `825, `760, and `838 Patents;
- B. An award of damages to be paid by Defendant adequate to compensate Chrimar for Defendant's past infringement of the Patents-in-Suit and any continuing or future infringement through the date such judgment is entered (but in no event less than a reasonable royalty in accordance with 35 U.S.C. § 284), including interest, costs, expenses and an accounting of all infringing acts including, but not limited to, those acts not presented at trial;
- C. A preliminary and permanent injunction enjoining Defendant and its officers, agents, servants, employees, users, attorneys, and all those persons in active concert or participation with Defendant from the acts described in this Complaint;
- D. Alternatively, an order requiring Defendant to pay an ongoing royalty in an amount to be determined for any continued infringement after the date judgment is entered;
- E. An award of pre-judgment and post-judgment interest to the full extent allowed under the law, as well as their costs;
- F. A declaration that this case is exceptional under 35 U.S.C. § 285, and an award of Chrimar's reasonable attorneys' fees;
- G. An award to Chrimar of such further relief at law or in equity as the Court deems just and proper.

Dated: January 15, 2019

Respectfully submitted,

/s/ Gary R. Sorden

Gary R. Sorden

Texas Bar No. 24066124

gary.sorden@klemchuk.com

Brian L. King

Texas Bar No. 24055776

Brian.king@klemchuk.com

Timothy J.H. Craddock

Texas Bar No. 24082868

tim.craddock@klemchuk.com

KLEMCHUK LLP

8150 N. Central Expressway

10th Floor

Dallas, Texas 75206

Tel: 214-367-6000

Fax: 214-367-6001

ATTORNEY FOR PLAINTIFFS

CHRIMAR SYSTEMS, INC. D/B/A CMS

TECHNOLOGIES AND CHRIMAR HOLDING

COMPANY, LLC