

**UNITED STATES DISTRICT COURT  
EASTERN DISTRICT OF TEXAS  
MARSHALL DIVISION**

**DYNAMIC DATA TECHNOLOGIES, LLC,**

*Plaintiff,*

v.

**AMAZON.COM, INC.; AMAZON WEB  
SERVICES, INC.; AMAZON DIGITAL  
SERVICES, LLC,**

*Defendants.*

**Civil Action No. 2:18-cv-461-RWS**

**JURY TRIAL DEMANDED**

**FIRST AMENDED COMPLAINT FOR PATENT INFRINGEMENT**

Dynamic Data Technologies, LLC (“Dynamic Data”) bring this action and make the following allegations of patent infringement relating to U.S. Patent Nos.: 8,135,073 (the “073 patent”); 8,073,054 (the “054A patent”); 6,774,918 (the “918 patent”); 8,184,689 (the “689 patent”); 6,996,177 (the “177 patent”); 8,311,112 (the “112 patent”); 7,894,529 (the “529 patent”); 7,519,230 (the “230 patent”); 7,571,450 (the “450 patent”); 6,639,944 (the “944 patent”); 6,782,054 (the “054B patent”); 7,010,039 (the “039 patent”); 7,058,227 (the “227 patent”); and 8,189,105 (the “105 patent”) (collectively, the “patents-in-suit”). Defendants Amazon.com, Inc., Amazon Web Services, Inc., and Amazon Digital Services, LLC (collectively, “Amazon” or “Defendant”) infringes each of the patents-in-suit in violation of the patent laws of the United States of America, 35 U.S.C. § 1 *et seq.*

**INTRODUCTION**

1. Dynamic Data’s portfolio of over 1,200 patent assets encompasses core technologies in the field of image and video processing. Dynamic Data’s patents arose from the research and development efforts of Koninklijke Philips N.V. (“Philips”). Founded in 1891, for

well over a century, Philips pioneered ground breaking technologies, including compact audio cassettes, magnetic resonance imaging (MRI) machines, and compact discs.

2. In addition to ensuring that its intellectual property is appropriately licensed, Dynamic Data has expanded its portfolio of motion estimation and motion compensation patents. On November 19, 2018, Dynamic Data acquired a further set of 85 patent assets from NXP B.V. relating to motion estimation and motion compensation.<sup>1</sup>

**DYNAMIC DATA’S LANDMARK INVENTIONS**

3. The groundbreaking inventions in image and video processing taught in the patents-in-suit were pioneered by Philips. Video and image processing were at the heart of Philips’ business for over fifty years. In 1891, Philips, then known as Philips & Company, was founded in Eindhoven, Netherlands to manufacture carbon-filament lamps.<sup>2</sup> In the 1920s, Philips began to produce vacuum tubes and small radios, which would augur Philips’ later entry into video and audio processing.



N.A. Halbertsma, *The Birth of a Lamp Factory In 1891*, PHILIPS TECHNICAL REVIEW, Vol. 23 at 230, 234 (1961).

<sup>1</sup> Three of the patents-in-suit asserted for the first time in this First Amended Complaint were acquired by Dynamic Data in its November 19, 2018 transaction with NXP B.V. Those patents are: U.S. Patent Nos. 6,639,944; 6,782,054; and 7,058,227.

<sup>2</sup> Gerard O’Regan, A BRIEF HISTORY OF COMPUTING at 99 (2012).

4. In 1962, Philips introduced the first audio cassette tape.<sup>3</sup> A year later, Philips launched a small battery-powered audio tape recorder that used a cassette instead of a loose spool.<sup>4</sup> Philips C-cassette was later used as the first mass storage device for early personal computers in the 1970s and 1980s.



THE ROTARIAN MAGAZINE, Vol. 101 No. 6 at 70 (December 1962) (advertisement showing Philips Norelco device which used cassettes for recording audio for transcription); Fred Chandler, *European Mfrs. Bid For Market Share*, BILLBOARD MAGAZINE AT P-6 (April 8, 1967) (image of the Philips EL 3300 battery-operated tape recorder which was released in 1963); Jan Syrjala, *Car Stereo: How Does The Music Sound?*, N.Y. TIMES at 2-M (September 25, 1966) (showing Philips's Norelco Cassette "the Philips device has two tiny reels inside it, with the tape traveling from one to the other").

5. In 1971, Philips demonstrated the world's first videocassette records (VCR). A year later, Philips launched the world's first home video cassette recorder, the N1500. In 1982, Philips teamed with Sony to launch the Compact Disc; this format evolved into the DVD and later Blu-ray, which Philips launched with Sony in 1997 and 2006 respectively.

<sup>3</sup> Gerard O'Regan, PILLARS OF COMPUTING: A COMPENDIUM OF SELECT, PIVOTAL TECHNOLOGY FIRMS at 172 (2015) ("Philips invented the compact cassette for audio storage in 1962.")

<sup>4</sup> Anthony Pollard, GRAMOPHONE: THE FIRST 75 YEARS at 231 (1998).

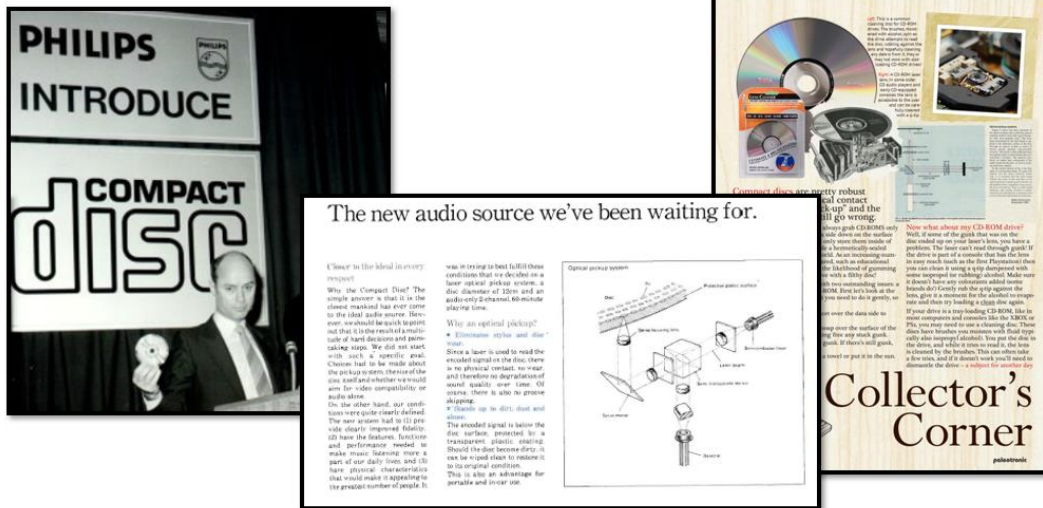

Hans Peek, Jan Bergmans, Jos Van Haaren, Frank Toolenaar, and Sorin Stan, ORIGINS AND SUCCESSORS OF THE COMPACT DISC: CONTRIBUTIONS OF PHILIPS TO OPTICAL STORAGE at 15 (2009) (showing image of Joop Sinjou of Philips introducing the compact disc in March 1979); Advertisements for Philip’s Compact Disc Products (1982).

6. In the late 1990s and early 2000s, Philips pioneered the development of technologies for encoding and decoding of video and audio content. At the time most of the technologies claimed by the patents in Dynamic Data’s portfolio were invented, Philips’ subsidiary primarily responsible for Philips’ work in this field, Philips Semiconductor was the world’s sixth largest semiconductor company.<sup>5</sup> The video encoding technologies developed by Philips Semiconductor enable video streaming on set-top boxes, smartphones, popular gaming consoles, Internet-connected computers, and numerous other types of media streaming devices.

7. Philips Semiconductor dedicated significant research and development resources to advancing the technology of video compression and transmission by reducing file sizes and

<sup>5</sup> *Company News; Philips in \$1 Billion Deal for VLSI Technology*, THE NEW YORK TIMES (May 4, 1999), available at: <https://www.nytimes.com/1999/05/04/business/company-news-philips-in-1-billion-deal-for-vlsi-technology.html>.

decreasing the processing resources required to transmit the data.<sup>6</sup> Philips Semiconductor was among the first companies aggressively driving innovation in the field of video processing:

The late 1980s and early 1990s saw the announcement of several complex, programmable VSPs. Important examples include chips from Matsushita, NTT, Philips [Semiconductors], and NEC. All of these processors were high-performance parallel processors architected from the ground up for real-time video signal processing. . . . The Philips VSP-1 and NEC processor were probably the most heavily used of these chips.<sup>7</sup>

8. Starting in the 1960s Philips pioneered the development of audio and video technologies that would establish itself as a leader in the field that would later develop into the audio and video encoding fields. Continuing Philips' pioneering history in these fields, the patents-in-suit disclose cutting-edge video compression and transmission technologies.

#### **DYNAMIC DATA'S PATENT PORTFOLIO**

9. Dynamic Data's patent portfolio includes over 1,200 patent assets, with over 470 issued patents granted by patent offices around the world. Dynamic Data owns numerous patents issued by the United States Patent and Trademark Office, including each of the patents-in-suit, The State Intellectual Property Office of the People's Republic of China,<sup>8</sup> the European Patent Office,<sup>9</sup> the German Patent and Trademark Office,<sup>10</sup> the Japan Patent Office,<sup>11</sup> and many other national patent offices.

---

<sup>6</sup> HU, YU HEN, PROGRAMMABLE DIGITAL SIGNAL PROCESSORS: ARCHITECTURE, PROGRAMMING, AND APPLICATIONS, at 190 (Dec. 6, 2001) ("Philips Semiconductors developed early dedicated video chips for specialized video processors.").

<sup>7</sup> *Id.* at 191.

<sup>8</sup> *See, e.g.*, CN100504925C; CN100438609C; CN1679052B; CN1333373C; CN1329870C; CN1303818C.

<sup>9</sup> *See, e.g.*, European Patent Nos. EP1032921B1; EP1650978B1; EP1213700B1; EP1520409B1.

<sup>10</sup> *See, e.g.*, German Patent Nos. DE60120762; DE50110537; DE60126151; DE60348978; DE602004049357.

<sup>11</sup> *See, e.g.*, Japanese Patent Nos. JP4583924B2; JP5059855B2; JP5153336B2; JP4637585B2.

10. Philips Semiconductor's pioneering work in the area of video processing and encoding has resulted in various inventions that are fundamental to today's video processing technologies. Dynamic Data is the owner by assignment of over 1,200 of these patent assets, which include over 475 patents issued by patent offices around the world.

11. Highlighting the importance of the patents-in-suit is the fact that the patents-in-suit have been cited by over 400 U.S. and international patents and patent applications by a wide variety of the largest companies operating in the field. For example, the patents-in-suit have been cited by companies such as:

- Samsung Electronics Co., Ltd.<sup>12</sup>
- Qualcomm Inc.<sup>13</sup>
- Google LLC<sup>14</sup>
- Intel Corporation<sup>15</sup>
- Broadcom Corporation<sup>16</sup>
- Microsoft Corporation<sup>17</sup>
- Sony Corporation<sup>18</sup>
- Fujitsu Ltd.<sup>19</sup>
- Panasonic Corporation<sup>20</sup>
- Matsushita Electric Industrial Company Limited<sup>21</sup>

---

<sup>12</sup> See, e.g., U.S. Patent Nos. 6,930,729; 7,911,537; 7,532,764; 8,605,790; and 8,095,887.

<sup>13</sup> See, e.g., U.S. Patent Nos. 7,840,085; 8,649,437; 8,750,387; 8,918,533; 9,185,439; 9,209,934; 9,281,847; 9,319,448; 9,419,749; 9,843,844; 9,917,874; and 9,877,033.

<sup>14</sup> See, e.g., U.S. Patent No. 8,787,454 and U.S. Patent Appl. No. 10/003,793.

<sup>15</sup> See, e.g., U.S. Patent Nos. 7,554,559; 7,362,377; and 8,462,164.

<sup>16</sup> See, e.g., U.S. Patent Nos. 8,325,273 and 9,377,987.

<sup>17</sup> See, e.g., U.S. Patent Nos. 7,453,939; 7,670,227; 7,408,986; 7,421,129; 7,558,320; and 7,929,599.

<sup>18</sup> See, e.g., U.S. Patent Nos. 7,218,354 and 8,174,615.

<sup>19</sup> See, e.g., U.S. Patent Nos. 7,092,032 and 8,290,308.

<sup>20</sup> See, e.g., U.S. Patent Nos. 8,164,687 and 8,432,495.

<sup>21</sup> See, e.g., U.S. Patent Nos. 7,362,378 and 7,423,961.

**THE PARTIES**

**DYNAMIC DATA TECHNOLOGIES, LLC**

12. Dynamic Data Technologies, LLC (“Dynamic Data” or “Plaintiff”) is a limited liability company organized under the laws of Delaware.

13. In an effort to obtain compensation for Philips’ pioneering work in the fields of video data encoding, decoding, and transmission, Dynamic Data acquired the patents-in-suit along with the several hundred additional issued United States and international Patents.

14. Dynamic Data pursues the reasonable royalties owed for Amazon’s use of the inventions claimed in Dynamic Data’s patent portfolio, which primarily arise from Philips’ groundbreaking technology, both here in the United States and throughout the world.

**AMAZON**

15. On information and belief, Amazon.com, Inc. is a Delaware corporation with its principal place of business at 410 Terry Avenue North, Seattle, Washington 98109. Amazon.com, Inc. may be served through its registered agent, Corporation Service Company, 251 Little Falls Drive, Wilmington, Delaware 19808.

16. On information and belief, Amazon Digital Services, LLC is a Delaware limited liability company with a principal place of business at 410 Terry Avenue North, Seattle, Washington 98109. Amazon Digital Services, LLC may be served through its registered agent, Corporation Service Company, 251 Little Falls Drive, Wilmington, Delaware 19808.

17. On information and belief, Amazon Web Services, Inc. is a Delaware corporation with its principal office at 410 Terry Avenue North, Seattle, Washington 98109. Amazon Web Services, Inc. may be served through its registered agent, Corporation Service Company, 251 Little Falls Drive, Wilmington, Delaware 19808.

18. Amazon.com, Inc. is the parent company of wholly-owned subsidiaries Amazon Digital Services, LLC and Amazon Web Services, Inc. Amazon.com, Inc., Amazon Digital Services, LLC, and Amazon Web Services, Inc. are collectively referred to herein as “Amazon.”

19. On information and belief, Amazon conducts business operations within the Eastern District of Texas.

20. On information and belief, Amazon has a regular and established place of business in this District, including, for example, distribution facilities, employees, and contracts and control over third-party businesses providing resources and services to Amazon. For example, Amazon maintains fulfillment centers at 940 W. Bethel Road, Coppell, Texas 75019 and 15201 Heritage Parkway, Fort Worth, Texas 76177.

#### **JURISDICTION AND VENUE**

21. This action arises under the patent laws of the United States, Title 35 of the United States Code. Accordingly, this Court has exclusive subject matter jurisdiction over this action under 28 U.S.C. §§ 1331 and 1338(a).

22. Upon information and belief, this Court has personal jurisdiction over Amazon in this action because Amazon has committed acts within the Eastern District of Texas giving rise to this action and has established minimum contacts with this forum such that the exercise of jurisdiction over Amazon would not offend traditional notions of fair play and substantial justice. Defendant Amazon, directly and/or through subsidiaries or intermediaries (including distributors, retailers, and others), has committed and continues to commit acts of infringement in this District by, among other things, offering to sell and selling products and/or services that infringe the patents-in-suit. Moreover, Amazon has offices and facilities in the Eastern District of Texas, and actively directs its activities to customers located in the State of Texas.



23. On information and belief, Amazon has directly financially benefitted from doing business with the State of Texas. For example, Amazon has entered into contract (DIR-TSO-4221) with the State of Texas whereby Amazon is paid by the State of Texas to provide cloud computing and related services.

24. Venue is proper in this district under 28 U.S.C. §§ 1391(b)-(d) and 1400(b). Defendant Amazon has offices and facilities in the Eastern District of Texas, and upon information and belief, has transacted business in the Eastern District of Texas and has committed acts of direct and indirect infringement in the Eastern District of Texas.

### **THE ASSERTED PATENTS**

#### **U.S. PATENT NO. 8,135,073**

25. U.S. Patent No. 8,135,073 (the “’073 patent”) entitled, *Enhancing Video Images Depending on Prior Image Enhancements*, was filed on December 12, 2003, and claims priority to December 19, 2002. The ‘073 patent is subject to a 35 U.S.C. § 154(b) term extension of 1,799 days. Dynamic Data is the owner by assignment of all right, title, and interest in the ‘073 patent. A true and correct copy of the ‘073 patent is attached hereto as Exhibit 1.

26. The ‘073 patent discloses novel methods and systems for enhancing subsequent images of a video stream in which frames are encoded based on previous frames using prediction and motion estimation.

27. The inventions disclosed in the ‘073 patent reduce the processing capacity required for providing video enhancements to video processing through re-mapping of previous frames for subsequent frames.

28. Accordingly, the technologies disclosed in the ‘073 patent enable the provision of enhanced video pictures with minimal additional hardware costs for the components required to successfully process the video data.

29. The '073 patent discloses a video decoder comprising an input for receiving a video stream containing encoded frame based video information including an encoded first frame and an encoded second frame.

30. The '073 patent discloses a video decoder comprising an input for receiving video information wherein the encoding of the second frame depends on the encoding of the first frame, the encoding of the second frame includes motion vectors indicating differences in positions between regions of the second frame and corresponding regions of the first frame, the motion vectors define correspondence between regions of the second frame and corresponding regions of the first frame.

31. The '073 patent discloses a video decoder comprising a decoding unit for decoding the frames, wherein the decoding unit recovers the motion vectors for the second frame.

32. The '073 patent discloses a video decoder comprising a processing component configured to determine a re-mapping strategy for video enhancement of the decoded first frame using a region-based analysis, re-map the first frame using the re-mapping strategy, and re-map one or more regions of the second frame depending on the re-mapping strategy for corresponding regions of the first frame.

33. The '073 patent and its underlying patent application have been cited by 36 patents and patent applications as relevant prior art. Specifically, patents issued to the following companies have cited the '073 patent and its underlying patent application as relevant prior art:

- Canon Inc.
- Microsoft Corporation
- International Business Machines Corporation
- Qualcomm Inc.
- Digital Fountain Incorporated
- Samsung Electronics Co., Ltd.
- SK Planet Co. Ltd.

**U.S. PATENT NO. 8,073,054**

34. U.S. Patent No. 8,073,054 (the “‘054A patent”) entitled, *Unit For And Method Of Estimating A Current Motion Vector*, was filed on December 12, 2002, and claims priority to January 17, 2002. The ‘054A patent is subject to a 35 U.S.C. § 154(b) term extension of 1,162 days. Dynamic Data is the owner by assignment of all right, title, and interest in the ‘054A patent. A true and correct copy of the ‘054A patent is attached hereto as Exhibit 2.

35. The ‘054A patent discloses novel methods and apparatuses for estimating a current motion vector for a group of pixels of an image.

36. The inventions disclosed in the ‘054A patent enable motion estimation with a relatively fast convergence in finding the appropriate motion vectors of the motion vector fields by adding a further candidate motion vector to the set of candidate motion vectors.

37. The ‘054A patent discloses a motion estimation unit comprising a generating unit for generating a set of candidate motion vectors for the group of pixels, with the candidate motion vectors being extracted from a set of previously estimated motion vectors.

38. The ‘054A patent discloses a motion estimation unit comprising a match error unit for calculating match errors of respective candidate motion vectors.

39. The ‘054A patent discloses a motion estimation unit comprising a selector for selecting the current motion vector from the candidate motion vectors by means of comparing the match errors of the respective candidate motion vectors, characterized in that the motion estimation unit is arranged to add a further candidate motion vector to the set of candidate motion vectors by calculating the further candidate motion vector on basis of a first motion vector and a second motion vector, both belonging to the set of previously estimated motion vectors.

40. The ‘054A patent discloses a motion estimation unit that calculates the further candidate motion vector on basis of the first motion vector and the second motion vector, with the

first motion vector belonging to a first forward motion vector field and the second motion vector belonging to a second forward motion vector field, with the first forward motion vector field and the second forward motion vector field being different.

41. The '054A patent discloses a motion estimation unit that arranges to calculate the further candidate motion vector by means of calculating a difference between the second motion vector and the first motion vector.

42. The '054A patent and its underlying patent application have been cited by 14 patents and patent applications as relevant prior art. Specifically, patents issued to the following companies have cited the '054A patent and its underlying patent application as relevant prior art:

- Canon Inc.
- Huawei Technologies, Ltd.
- Imagination Technologies Ltd.
- MediaTek Inc.
- Panasonic Corp.
- Samsung Electronics Co., Ltd.
- Siemens Healthcare GmbH
- Tencent Technology (Shenzhen) Co., Ltd.

**U.S. PATENT NO. 6,774,918**

43. U.S. Patent No. 6,774,918 (“the ‘918 patent”) entitled, *Video Overlay Processor with Reduced Memory And Bus Performance Requirements*, was filed on June 28, 2000. The ‘918 patent is subject to a 35 U.S.C. § 154(b) term extension of 591 days. Dynamic Data is the owner by assignment of all right, title, and interest in the ‘918 patent. A true and correct copy of the ‘918 patent is attached hereto as Exhibit 3.

44. The ‘918 patent claims specific methods and systems for providing an overlay such as a cursor in an on-screen display in a consumer electronic device. On-screen display (OSD) data

for generating an image on a display device are downloaded to an OSD unit on an integrated circuit.

45. The '918 patent discloses downloading on-screen display (OSD) data for generating an image on a display device.

46. The '918 patent further discloses downloading the on-screen display (OSD) data in segments separated by gaps.

47. The '918 patent further discloses, during a gap in downloading the on-screen display data, downloading an amount of overlay data for generating an overlay on the image generated on a display device.

48. Further, the '918 patent discloses that the overlay data downloaded during a gap comprises a portion of the overlay data.

49. The inventions disclosed in the '918 patent improve the operation and efficiency of computer components because only a portion of the overlay data is downloaded during each burst gap, thus reducing the amount of memory needed to store the overlay data. The inventions disclosed in the '918 patent further eliminate the requirement that on-chip memory be large enough to hold the data needed for an entire overlay. Instead, only one line or a part of one line of the overlay needs to be stored on-chip.

50. The '918 patent claims a technical solution to a problem unique to video processing.

51. The '918 patent has been cited by several United States patents and patent applications as relevant prior art. Specifically, patents issued to Realtek Semiconductor Corp., Samsung Electronics Co., Ltd., and Thomson Licensing SA have all cited the '918 patent as relevant prior art.

**U.S. PATENT NO. 8,184,689**

52. U.S. Patent No. 8,184,689 (the “‘689 patent”) entitled, *Method Video Encoding And Decoding Preserving Cache Localities*, was filed on August 7, 2006, and claims priority to August 17, 2005. The ‘689 patent is subject to a 35 U.S.C. § 154(b) term extension of 948 days. Dynamic Data is the owner by assignment of all right, title, and interest in the ‘689 patent. A true and correct copy of the ‘689 patent is attached hereto as Exhibit 4.

53. The ‘689 patent discloses novel methods and apparatuses for encoding and decoding video data.

54. The inventions disclosed in the ‘689 patent processing time and power consumption associated with encoding and decoding video stream data is reduced by reducing off-chip memory accesses through using simultaneous encoded/decoded images as a reference image for encoding/decoding at least one of the other simultaneously encoded/decoded images.

55. The ‘689 patent discloses a method for encoding and decoding a video stream, including a plurality of images in a video processing apparatus having a processing unit coupled to a first memory, further comprising a second memory.

56. The ‘689 patent discloses a method for encoding and decoding a video stream comprising providing a subset of image data stored in the second memory in the first memory.

57. The ‘689 patent discloses a method for encoding and decoding a video stream comprising simultaneous encoding/decoding of more than one image of the video stream, by accessing said subset, wherein the simultaneously encoding/decoding is performed by access sharing to at least one image.

58. The ‘689 patent and its underlying patent application have been cited by several patents and patent applications as relevant prior art. Specifically, patents issued to Fujitsu Ltd.,

Qualcomm Inc., Sony Corporation, Sun Patent Trust, and VIXS Systems Incorporated have all cited the '689 patent and its underlying patent application as relevant prior art.

**U.S. PATENT NO. 6,996,177**

59. U.S. Patent No. 6,996,177 (the “177 patent”) entitled, *Motion Estimation*, was filed on July 24, 2000, and claims priority to August 22, 1999. The '177 patent is subject to a 35 U.S.C. § 154(b) term extension of 1,103 days. Dynamic Data is the owner by assignment of all right, title, and interest in the '177 patent. A true and correct copy of the '177 patent is attached hereto as Exhibit 5.

60. The '177 patent claims specific methods and devices for motion estimation and motion-compensated picture signal processing.

61. The '177 patent discloses a motion vector estimation method and device that carries out a block-based motion vector estimation process that involves comparing a plurality of candidate vectors to determine block-based motion vectors.

62. The '177 patent discloses a motion vector estimation method and device that determines at least a most frequently occurring block-based motion vector.

63. The '177 patent discloses a motion vector estimation method and device that carries out a global motion vector estimation process using at least the most frequently occurring block-based motion vector to obtain a global motion vector.

64. The '177 patent discloses a motion vector estimation method and device that applies the global motion vector as a candidate vector to the block-based motion vector estimation process.

65. The inventions disclosed in the '177 patent improve the operation of the computer components necessary to the performance of picture signal processing by reducing the load on the central processing unit.

66. The '177 patent has been cited by 16 United States and International patents and patent applications as relevant prior art. Specifically, patents issued to the following companies have cited the '177 patent as relevant prior art:

- Qualcomm Incorporated
- LG Electronics
- Microsoft Corporation
- Samsung Electronics Co., Ltd.
- VIXS Systems Incorporated
- General Instrument Corporation

**U.S. PATENT NO. 8,311,112**

67. U.S. Patent No. 8,311,112 (the "'112 patent") entitled, *System And Method For Video Compression Using Predictive Coding*, was filed on December 31, 2008. The '112 patent is subject to a 35 U.S.C. § 154(b) term extension of 847 days. Dynamic Data is the owner by assignment of all right, title, and interest in the '112 patent. A true and correct copy of the '112 patent is attached hereto as Exhibit 6.

68. The '112 patent discloses novel methods and systems for video compression.

69. The '112 patent discloses novel technologies for video compression that perform predictive coding on a macroblock of a video frame such that a set of pixels of the macroblock is coded using some of the pixels from the same video frame as reference pixels and the rest of the macroblock is coded using reference pixels from at least one other video frame.

70. The '112 patent discloses a system for video compression comprising an intra-frame coding unit configured to perform predictive coding on a set of pixels of a macroblock of



pixels using a first group of reference pixels, the macroblock of pixels and the first group of reference pixels being from a video frame.

71. The '112 patent discloses a system for video compression comprising an inter-frame coding unit configured to perform predictive coding on the rest of the macroblock of pixels using a second group of reference pixels, the second group of reference pixels being from at least one other video frame.

72. The '112 patent and its underlying patent application have been cited by 10 patents and patent applications as relevant prior art. Specifically, patents issued to the following companies have cited the '112 patent and its underlying patent application as relevant prior art:

- British Broadcasting Corporation
- Google LLC
- Megachips Corp.
- Olympus Corp.
- Samsung Electronics Co., Ltd.
- Sony Corporation
- Toshiba Corporation

**U.S. PATENT NO. 7,894,529**

73. U.S. Patent No. 7,894,529 (the "'529 patent") entitled, *Method And Device For Determining Motion Vectors*, was filed on June 1, 2006, and claims priority to June 3, 2005. The '529 patent is subject to a 35 U.S.C. § 154(b) term extension of 1,301 days. Dynamic Data is the owner by assignment of all right, title, and interest in the '529 patent. A true and correct copy of the '529 patent is attached hereto as Exhibit 7.

74. The '529 patent discloses novel methods and apparatuses for determining motion vectors that are each assigned to individual image regions.

75. The inventions disclosed in the '529 patent enable an increase in the resolution of video and image signals during the motion estimation process.

76. The '529 patent discloses a method for determining motion vectors which are assigned to individual image regions of an image.

77. The '529 patent discloses a method wherein an image is subdivided into a number of image blocks, and a motion estimation technique is implemented to assign at least one motion vector to each of the image blocks where a modified motion vector is generated for at least a first image block.

78. The '529 patent discloses a method that determines at least a second image block through which the motion vector assigned to the first image block at least partially passes.

79. The '529 patent discloses a method that generates the modified motion vector as a function of a motion vector assigned to at least the second image block.

80. The '529 patent discloses a method that assigns the modified motion vector as the motion vector to the first image block.

81. The '529 patent and its underlying patent application have been cited by multiple patents and patent applications as relevant prior art. Specifically, patents issued to Fujifilm Corp., and Samsung Electronics Co., Ltd. have cited the '529 patent and its underlying patent application as relevant prior art.

**U.S. PATENT NO. 7,519,230**

82. U.S. Patent No. 7,519,230 (the "'230 patent") entitled, *Background Motion Vector Detection*, was filed on December 16, 2003, and claims priority to January 23, 2003. The '230 patent is subject to a 35 U.S.C. § 154(b) term extension of 685 days. Dynamic Data is the owner of all right, title, and interest in the '230 patent. A true and correct copy of the '230 patent is attached hereto as Exhibit 8.

83. The '230 patent claims specific methods and systems to select a background motion vector for a pixel in an occlusion region of an image.

84. The '230 patent discloses systems and methods determine the correct motion vector in occlusion regions, thereby reducing or eliminating artifacts of motion compensated image rate converters, which are referred to as "halos" in the display of video images.

85. The '230 patent claims a method of selecting a background motion vector for a pixel in an occlusion region of an image comprising computing a model-based motion vector for the pixel on basis of a motion model being determined on basis of a part of a motion vector field of the image.

86. The '230 patent claims a method of selecting a background motion vector for a pixel in an occlusion region of an image comprising comparing the model-based motion vector with each of the motion vectors of the set of motion vectors.

87. The '230 patent claims a method of selecting a background motion vector for a pixel in an occlusion region of an image comprising selecting a particular motion vector of the set of motion vectors on basis of the comparing and for assigning the particular motion vector as the background motion vector.

88. The '230 patent has been cited by 28 United States and international patents and patent applications as relevant prior art. Specifically, patents issued to the following companies have cited the '230 patent as relevant prior art:

- Sony Corporation
- Fujitsu Ltd.
- Motorola Solutions Inc.
- Nokia Oyj
- Qualcomm Inc.
- Samsung Electronics Co., Ltd.
- Toshiba Corporation

**U.S. PATENT NO. 7,571,450**

89. U.S. Patent No. 7,571,450 (the “‘450 patent”) entitled, *System For And Method Of Displaying Information*, was filed on February 12, 2003, and claims priority to March 11, 2002. The ‘450 patent is subject to a 35 U.S.C. § 154(b) term extension of 846 days. Dynamic Data is the owner by assignment of all right, title, and interest in the ‘450 patent. A true and correct copy of the ‘450 patent is attached hereto as Exhibit 9.

90. The ‘450 patent discloses novel methods and systems for displaying information. The inventions disclosed in the ‘450 patent enable methods and systems wherein a user does not need to make a new selection after being switched from one service to a second service.

91. The inventions disclosed in the ‘450 patent permit a user of an information display system to have selections made on a first service also presented when the user switches to a second service without requiring the user to browse through the menus to define the type of information to be displayed a second time.

92. In one embodiment of the ‘450 patent, the user selection being made on the basis of the provided options while the first service was selected is use to select the appropriate data elements of the stream of the second service.

93. The inventions disclosed in the ‘450 patent enable various content sources to share similar information models.

94. The ‘450 patent, in one embodiment, discloses a method of displaying information on a display device wherein receiving a transport stream comprises services, with the services having elementary streams of video and of data elements.

95. The ‘450 patent, in one embodiment, discloses a method of displaying information on a display device wherein user actions of making a user selection of a type of information to be displayed on the device are received.

96. The '450 patent, in one embodiment, discloses a method of displaying information on a display device wherein filtering to select a data element of a first one of the services on the basis of the user selection is performed.

97. The '450 patent, in one embodiment, discloses a method of displaying information on a display device wherein rendering to calculate an output image to be displayed on the display device, on the basis of the first data element selected by the filer is performed.

98. The '450 patent, in one embodiment, discloses a method of displaying information on a display device wherein switching from the first one of the services to a second one of the services, characterized in comprising a second step of filtering to select a second data-element of the second one of the services, on basis of the user selection is performed.

99. The '450 patent, in one embodiment, discloses a method of displaying information on a display device wherein being switched from the first one of the services to the second one of the services, with the data-element and the second data-element being mutually semantically related and a second step of rendering to calculate the output image to be displayed on the display device, on basis of the second data-element selected by the filter is performed.

100. The '450 patent and its underlying patent application have been cited by several patents and patent applications as relevant prior art. Specifically, patents issued to AT&T Intellectual Property I LP, Nokia Oyj, Samsung Electronics Co., Ltd., and ZTE Corporation have all cited the '450 patent and its underlying patent application as relevant prior art.

**U.S. PATENT NO. 6,639,944**

101. U.S. Patent No. 6,639,944 entitled, *Sub-Pixel Accurate Motion Vector Estimation And Compensated Interpolation*, was filed on April 26, 2000, and claims priority to April 26, 1999. Dynamic Data is the owner by assignment of all right, title, and interest in the '944 patent. A true and correct copy of the '944 patent is attached hereto as Exhibit 10.

102. The '944 patent discloses novel methods and systems for sub-pixel accurate motion vector estimation and motion-compensated interpolation or prediction.

103. The inventions disclosed in the '944 patent enables higher accuracy motion estimation at a lower cost through improvements in motion vector estimation and motion-compensated interpolation.

104. The '944 patent discloses a method of generating an intermediate image using sub-pixel accurate motion vectors having vector components that may have non-integer values, from first and second images having a given mutual temporal distance, the intermediate image being at a fractional distance from said first image, said fractional distance being a fraction of said given mutual temporal distance.

105. The '944 patent discloses a method that includes deriving first and second vectors from said sub-pixel accurate motion vectors.

106. The '944 patent discloses a method that includes generating an intermediate image by combining first positions in a first image shifted over first vectors and second positions in said second image shifted over second vectors.

107. The '944 patent discloses a method that includes deriving first and second vectors from sub-pixel accurate motion vectors by multiplying the vector components of the sub-pixel accurate motion vectors by a fraction to obtain fractional vector components.

108. The '944 patent discloses a method that includes deriving first and second vectors from sub-pixel accurate motion vectors by rounding the fractional vector components to obtain vector components of the first vectors, which have only integer vector components.

109. The '944 patent discloses a method that includes deriving first and second vectors from sub-pixel accurate motion vectors by subtracting the first vector from the candidate vector to

obtain the second vector, whereby the second vectors have vector components that, depending on the candidate vector and the fraction, may have non-integer values.

110. The '944 patent and its underlying patent application have been cited by 23 patents and patent applications as relevant prior art. Specifically, patents issued to the following companies have cited the '944 patent and its underlying patent application as relevant prior art: Himax Media Solutions, Inc.; Cyberlink Corp.; and Marvell International Ltd.

**U.S. PATENT NO. 6,782,054**

111. U.S. Patent No. 6,782,054 entitled, *Method And Apparatus For Motion Vector Estimation*, was filed on April 20, 2001. The '054B patent is subject to a 35 U.S.C. § 154(b) term extension of 485 days. Dynamic Data is the owner by assignment of all right, title, and interest in the '054B patent. A true and correct copy of the '054B patent is attached hereto as Exhibit 11.

112. The '054B patent discloses novel methods and systems for motion estimation in a sequence of moving video pictures.

113. The inventions disclosed in the '054B patent increase the speed of convergence of motion vectors to improve the convergence process.

114. The '054B patent discloses a method to enhance motion estimation that includes selecting a displacement vector as a best motion vector for a region in a field from a plurality of at least two candidate motion vectors by applying an error function to each of said plural candidate motion vectors, wherein the candidate motion vector with the least error is selected as the displacement vector for the region in the field.

115. The '054B patent discloses a method to enhance motion estimation that includes an error function comprising a first penalty term that depends on a type of the candidate motion vector and a second penalty term that depends on the position and size of the candidate motion vector.

116. The '054B patent and its underlying patent application have been cited by 54 patents and patent applications as relevant prior art. Specifically, patents issued to the following companies have cited the '054B patent and its underlying patent application as relevant prior art:

- Samsung Electronics Co., Ltd.
- Sony Corporation
- MediaTek Inc.
- Qualcomm Incorporated
- Micronas GmbH
- Google Inc.
- Thomson Licensing
- Brightscale, Inc.
- Genesis Microchip Inc.
- STMicroelectronics SA
- Toshiba Corp.

**U.S. PATENT NO. 7,010,039**

117. U.S. Patent No. 7,010,039 (the "'039 patent") entitled, *Motion Estimator for Reduced Halos in MC Up-Conversion*, was filed on May 15, 2001, and claims priority to May 18, 2000. The '039 patent is subject to a 35 U.S.C. § 154(b) term extension of 768 days. Dynamic Data is the owner by assignment of all right, title, and interest in the '039 patent. A true and correct copy of the '039 patent is attached hereto as Exhibit 12.

118. The '039 patent claims specific methods and apparatuses detecting motion at a temporal intermediate position between previous and next images. The inventions disclosed in the '039 patent solve a problem wherein an estimator estimating motion between two successive pictures from a video sequence cannot perform well in areas where covering or uncovering occurs.

119. The '039 patent solves this problem by carrying out the optimization at the temporal position of the next image in covering areas and at the temporal position of the previous image in uncovering areas.



120. The '039 patent discloses a method and apparatus for detecting motion at a temporal intermediate position between previous and next images.

121. The '039 patent discloses the use of a criterion function for selecting and optimizing candidate vectors.

122. The '039 patent further discloses a criterion function that depends on data from both previous and next images and in which the optimizing is carried out at the temporal intermediate position in non-covering and non-uncovering areas, characterized in that the optimizing is carried out at the temporal position of the next image in covering areas and at the temporal position of the previous image in uncovering areas.

123. The '039 patent and its related patents have been cited by 30 United States and International patents and patent applications as relevant prior art. Specifically, patents issued to the following companies have cited the '039 patent family as relevant prior art:

- Qualcomm Incorporated
- Panasonic Corporation
- Samsung Electronics Co., Ltd.
- Matsushita Electric Industrial Co., Ltd.
- Sharp Kabushiki Kaisha
- Integrated Device Technology, Inc.
- Zoran Corporation

**U.S. PATENT NO. 7,058,227**

124. U.S. Patent No. 7,058,227 entitled, *Problem Area Location In An Image Signal*, was filed on July 17, 2002, and claims priority to August 21, 1998. The '227 patent is subject to a 35 U.S.C. § 154(b) term extension of 723 days. Dynamic Data is the owner by assignment of all right, title, and interest in the '227 patent. A true and correct copy of the '227 patent is attached hereto as Exhibit 13.

125. The '227 patent discloses novel methods and systems for detecting occlusion and reducing halo effects in motion compensated pictures.

126. The '227 patent further discloses a method and device for interpolating images between existing images.

127. The '227 patent discloses technologies capable of adapting the interpolation strategy depending on a segmentation of the image in various areas.

128. The '227 patent discloses a method of locating problem areas in an image signal that includes estimating a motion vector field for the image signal.

129. The '227 patent discloses a method of locating problem areas in an image signal that includes detecting edges in the motion vectors field.

130. The '227 patent discloses a method of locating problem areas in an image signal that includes comparing edge locations in successive field periods to identify both foreground and background.

131. The '227 patent and its underlying patent application have been cited by 43 patents and patent applications as relevant prior art. Specifically, patents issued to the following companies have cited the '227 patent and its underlying patent application as relevant prior art:

- Integrated Device Technology, Inc.
- Qualcomm Inc.
- MediaTek Inc.
- Mitsubishi Denki Kabushiki Kaisha
- Panasonic Corporation
- Samsung Electronics Co., Ltd.
- Sony Corporation

**U.S. PATENT NO. 8,189,105**

132. U.S. Patent No. 8,189,105 entitled, *Systems and Methods of Motion and Edge Adaptive Processing Including Motion Compensation Features*, was filed on October 17, 2007.

The '105 patent is subject to a 35 U.S.C. § 154(b) term extension of 1258 days. Dynamic Data is the owner by assignment of all right, title, and interest in the '105 patent. A true and correct copy of the '105 patent is attached hereto as Exhibit 14.

133. The '105 patent discloses novel systems and methods for processing pixel information based on received motion and edge data.

134. The '105 patent further discloses the use of a blending component (implemented by hardware, software, firmware, combinations thereof, etc.) that implements interpolating intensity of the pixel to equal to the first intensity estimate if motion reliability data is below a threshold.

135. The '105 patent in one embodiment teaches using segmentation to average four contiguous pixels into one averaged pixel segment during motion detection.

136. The '105 patent and its underlying patent applications and foreign counterparts have been cited by 46 patents and patent applications as relevant prior art. Specifically, patents issued to the following companies have cited the '105 patent and its underlying patent application as relevant prior art:

- Flextronics Ap, LLC
- Qingdao Hisense Electronics Co., Ltd.
- Hon Hai Precision Industry Co., Ltd.
- Intel Corporation
- Sony Corporation
- Fujitsu Corporation
- Himax Media Solutions, Inc.
- Ati Technologies Ulc
- Sharp Kabushiki Kaisha
- Xerox Corporation

**COUNT I**  
**INFRINGEMENT OF U.S. PATENT NO. 8,135,073**

137. Dynamic Data references and incorporates by reference the preceding paragraphs of this Complaint as if fully set forth herein.

138. Amazon designs, makes, uses, sells, and/or offers for sale in the United States products and/or services for enhancing subsequent images of a video stream in which frames are encoded based on previous frames using prediction and motion estimation.

139. Amazon designs, makes, sells, offers to sell, imports, and/or uses Amazon products capable of decoding video data in compliance with the H.265 standard. By way of example, the following Amazon Products perform decoding pursuant to the H.265 standard: the Amazon Web Services platform (*e.g.*, AWS Elastic Transcoder, AWS Elemental MediaConvert, AWS Elemental MediaLive, Amazon EC2 Accelerated Compute (EC2 G3 Instances), Amazon CloudFront); Amazon Fire TV products (*e.g.*, Fire TV Stick 4k, Fire TV Cube, Fire TV (Gen 3), Fire TV (Gen 2), Fire TV Edition - Toshiba 4K (2018), Fire TV Edition - Element 4K (2018), Fire TV Edition - Insignia HD (2018), Fire TV Edition - Insignia 4k (2018), Fire TV Edition - Toshiba HD (2018)); and Amazon Fire Tablet products (*e.g.*, Fire HD 8 (2018), Fire HD 10 (2017), Fire HD 8 (2017), Fire 7 (2017), Fire HD 8 (2016), Fire HD 8 (2015), Fire HD 10 (2015)) (collectively, the “Amazon ‘073 Product(s)”).

140. On information and belief, one or more Amazon subsidiaries and/or affiliates use the Amazon ‘073 Products in regular business operations.

141. The accused Amazon Web Services platform products (*e.g.*, AWS Elastic Transcoder, AWS Elemental MediaConvert, AWS Elemental MediaLive, Amazon EC2 Accelerated Compute (EC2 G3 Instances), and Amazon CloudFront) comply with the HEVC

image processing standard. As shown in the following excerpts from Amazon Documentation the accused Amazon Web Services Platform functionalities comply with the HEVC standard.

Until recently, H.264 (also known as AVC) was the best codec for optimizing quality and reducing file sizes; many content publishers still use it today. But it's quickly giving way to HEVC: High-Efficiency Video Coding. It's also referred to as H.265; different standards groups employ different designations to refer to the same standard. HEVC requires more computing power than H.264, but it's more efficient. Because AWS Elemental writes all of its encoding software from scratch, rather than relying on off-the-shelf encoding software, it is able to take the efficiency gains in each new generation of codec and adjust the software accordingly to get the best quality and/ or smallest video file sizes, along with the shortest encoding times.

Alicia Hunt, *A Video Compression Primer*, AWS MEDIA BLOG (January 30, 2019), available at: <https://aws.amazon.com/blogs/media/a-video-compression-primer/> (emphasis added).

The screenshot shows a pricing table for AWS Elemental MediaLive. It has two tabs: 'Example 1' (selected) and 'Example 2'. The text reads: 'The per hour cost for a live channel with two HD inputs (using input switching) and producing 5 outputs with advanced audio in the US East (N. Virginia) Region:'. Under the heading 'Input', it lists two items: '1080p HD, HEVC, 20Mbps = \$0.600 per hour' and '1080p HD, HEVC, 20Mbps = \$0.600 per hour'.

*AWS Elemental MediaLive Pricing*, AWS DOCUMENTATION, available at: <https://aws.amazon.com/medialive/pricing/>

The screenshot shows a section titled 'Comprehensive Input and Output Support' with the sub-heading 'Create streams using standard video formats'. The text states: 'AWS Elemental MediaConvert supports a broad range of video input and output formats, including those for broadcast as well as formats for delivery over the internet. The service supports the MPEG-2, AVC, Apple ProRes, and HEVC compression standards—including support for advanced color sampling (10-bit 4:2:2). It supports a broad range of adaptive bitrate packaging formats including CMAF, Apple HLS, DASH ISO, and Microsoft Smooth Streaming. AWS Elemental MediaConvert also supports processing and conversion of 4K resolution and high dynamic range (HDR) video content.'

*AWS Elemental MediaConvert*, AWS DOCUMENTATION, available at: <https://aws.amazon.com/mediaconvert/features/> (AWS Elemental MediaConvert supports a broad range of video input and output formats . . . [t]he service supports . . . HEVC compression standards.”).

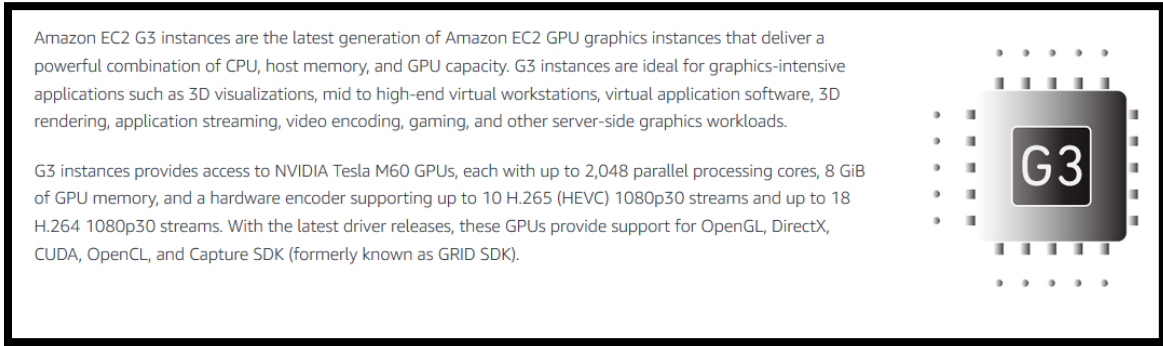

*Amazon EC2 G3 Instances, AWS DOCUMENTATION, available at: <https://aws.amazon.com/ec2/instance-types/g3/> (“G3 instances provides access to NVIDIA Tesla M60 GPUs, each with up to 2,048 parallel processing cores, 8 GiB of GPU memory, and a hardware encoder supporting up to 10 H.265 (HEVC) 1080p30 streams and up to 18 H.264 1080p30 streams.”).*

142. The accused Amazon Fire TV Products (e.g., Fire TV Stick 4k, Fire TV Cube, Fire TV (Gen 3), Fire TV (Gen 2), Fire TV Edition - Toshiba 4K (2018), Fire TV Edition - Element 4K (2018), Fire TV Edition - Insignia HD (2018), Fire TV Edition - Insignia 4k (2018), Fire TV Edition - Toshiba HD (2018)) comply with the HEVC image processing standard. The below excerpt from Amazon Fire TV Developer documentation describes the accused Amazon Fire TV Products as complying with the requirements of the HEVC standard.

Fire TV Stick 4K			
Type	Codec	MIME type	Details
Video	H.265 (HEVC) (High Efficiency Video Coding)	video/hevc	Hardware accelerated up to 3840x2160p (4K) @ 60fps, 35 Mbps, Main 10 Profile Level 5.1, Color space 8-bit and 10-bit input with HDR10, HDR10+, HLG, and Dolby Vision support in rendering pipelines.

*Device Specifications for Fire TV, AMAZON DEVELOPER DOCUMENTATION, available at: <https://developer.amazon.com/docs/fire-tv/device-specifications.html> (describing the HEVC encoding and decoding support for the Amazon Fire TV Products).*

143. The accused Amazon Fire Tablet Products (e.g., Fire HD 8 (2018), Fire HD 10 (2017), Fire HD 8 (2017), Fire 7 (2017), Fire HD 8 (2016), Fire HD 8 (2015), Fire HD 10 (2015)) comply with the HEVC image processing standard. The below excerpt from Amazon Fire Tablet

Developer documentation describes the accused Amazon Fire Tablet Products as complying with the requirements of the HEVC standard.

H.264 AVC	D (HW) High profile, L4.1 1080p@30FPS, E (HW)	D (HW) High profile, L4.1 Main Profile@L4 1080p@30FPS/4 0Mbps, E (HW)	D (HW) High profile, L4.1 Main Profile@L4 1080p@30FPS/4 0Mbps, E (HW)	D (HW) High profile, L4.1 1080p@30FPS, E (HW)
H.265 HEVC	D(HW) Main Profile L4 1080p@30FPS	D (HW) Main Profile L4 Main Profile@L4 1080p@30FPS/4 0Mbps	D (HW) Main Profile L4 Main Profile@L4 1080p@30FPS/4 0Mbps	D(HW) Main Profile L4 1080p@30FPS

*Amazon Fire TV Tablet Media Specifications*, AMAZON DEVELOPER DOCUMENTATION, available at: <https://developer.amazon.com/docs/fire-tablets/ft-media-specs-custom.html> (showing that the Fire HD 8 (2018), Fire HD 10 (2017), Fire HD 8 (2017) and Fire 7 (2017) support H.265 encoding compliant with the standard).

144. On information and belief, Amazon has directly infringed and continues to directly infringe the ‘073 patent by, among other things, making, using, offering for sale, and/or selling technology for enhancing subsequent images of a video stream in which frames are encoded based on previous frames using prediction and motion estimation, including but not limited to the Amazon ‘073 Products.

145. On information and belief, by complying with the HEVC standard, the Amazon devices – such as the Amazon ‘073 Products – necessarily infringe the ‘073 patent. The mandatory sections of the HEVC standard require the elements required by certain claims of the ‘073 patent, including but not limited to claim 14 of the ‘073 patent. *High Efficiency Video Coding*, SERIES H: AUDIOVISUAL AND Multimedia SYSTEMS: INFRASTRUCTURE OF AUDIOVISUAL SERVICES – CODING OF MOVING VIDEO REC. ITU-T H.265 (February 2018) (The following sections of the HEVC Standard are relevant to Amazon’s infringement of the ‘073 patent: “8.3.2 Decoding process for reference picture set;” “8.5.4 Decoding process for the residual signal of coding units coded in

inter prediction mode;” “8.6 Scaling, transformation and array construction process prior to deblocking filter process;” “8.5.2 Inter prediction process;” “8.5.3 Decoding process for prediction units in inter prediction mode;” and “8.7.2 Deblocking filter process;” “8.7.3 Sample adaptive offset process.”).

146. On information and belief, the Amazon ‘073 Products comply with the HEVC standard, which requires that motion vectors are recovered from the second frame in the video stream.

The decoding process for prediction units in inter prediction mode consists of the following ordered steps:

1. The derivation process for motion vector components and reference indices as specified in clause 8.5.3.2 is invoked with the luma coding block location ( xCb, yCb ), the luma prediction block location ( xBl, yBl ), the luma coding block size block nCbS, the luma prediction block width nPbW, the luma prediction block height nPbH and the prediction unit index partIdx as inputs, and the luma motion vectors mvL0 and mvL1, when ChromaArrayType is not equal to 0, the chroma motion vectors mvCL0 and mvCL1, the reference indices refIdxL0 and refIdxL1 and the prediction list utilization flags predFlagL0 and predFlagL1 as outputs.

*High Efficiency Video Coding, SERIES H: AUDIOVISUAL AND MULTIMEDIA SYSTEMS: INFRASTRUCTURE OF AUDIOVISUAL SERVICES – CODING OF MOVING VIDEO REC. ITU-T H.265 at § 8.5.3.1 (February 2018).*

147. On information and belief, Amazon has directly infringed and continues to directly infringe the ‘073 patent by, among other things, making, using, offering for sale, and/or selling technology for enhancing subsequent images of a video stream in which frames are encoded based on previous frames using prediction and motion estimation, including but not limited to the Amazon ‘073 Products.

148. The following excerpts explain how HEVC is a form of frame-based encoded video information.

One way of achieving high video compression is to predict pixel values for a frame based on prior and succeeding pictures in the video. Like its predecessors, H.265 features the ability to predict pixel values between pictures, and in particular, to specify in which order pictures are coded and which pictures are predicted from which. The coding order is specified for Groups Of Pictures (GOP), where a number of pictures are grouped together and predicted from each other in a



specified order. The pictures available to predict from, called reference pictures, are specified for every individual picture.

Johan Bartelmeß. *Compression Efficiency of Different Picture Coding Structures in High Efficiency Video Coding (HEVC)*, UPTEC STS 16006 at 4 (March 2016) (emphasis added).

149. On information and belief, the Amazon '073 Products receive encoded video data that is encoded using inter-frame coding. Specifically, the encoded video stream received by the Amazon '073 Products is coded using its predecessor frame. Inter-prediction used in the encoded video data received by the Amazon '073 Products allows a transform block to span across multiple prediction blocks for inter-picture predicted coding units to maximize the potential coding efficiency benefits of the quadtree-structured transform block partitioning.

The basic source-coding algorithm is a hybrid of interpicture prediction to exploit temporal statistical dependences, intrapicture prediction to exploit spatial statistical dependences, and transform coding of the prediction residual signals to further exploit spatial statistical dependences.

G. J. Sullivan, J.-R. Ohm, W.-J. Han, and T. Wiegand, *Overview of the High Efficiency Video Coding (HEVC) standard*, IEEE TRANS. CIRCUITS SYST. VIDEO TECHNOL., vol. 22, no. 12, p. 1654 (December 2012) (emphasis added).

150. The encoded video stream received by the Amazon '073 Products is encoded using inter-picture prediction that makes use of the temporal correlation between pictures to derive a motion-compensated prediction (MCP) for a block of image samples. For this block-based motion compensated prediction, a video picture is divided into rectangular blocks. Assuming homogeneous motion inside one block, and that moving objects are larger than one block, for each block, a corresponding block in a previously decoded picture can be found that serves as a predictor. The general concept of inter-frame-based encoding using motion-compensated prediction based on a translational motion model is illustrated below.

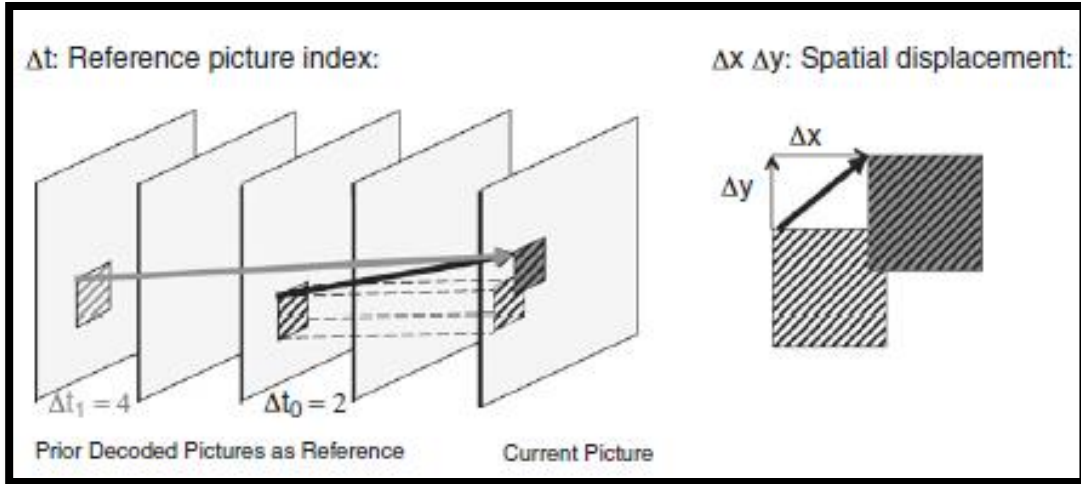

Benjamin Bross, *Inter-Picture Prediction In HEVC*, HIGH EFFICIENCY VIDEO CODING (HEVC) (Vivienne Sze, Madhukar Budagavi, and Gary J. Sullivan (Editors)) at 114 (September 2014).

151. The following excerpt from an article describing the architecture of the encoded video stream received by the Amazon ‘073 Products describes the functionality wherein the second encoded frame of the video data is dependent on the encoding of a first frame. “HEVC inter prediction uses motion vectors pointing to one reference frame . . . to predict a block of pixels.”

HEVC inter prediction uses motion vectors pointing to one reference frame (uni-prediction) or two reference frames (bi-prediction) to predict a block of pixels. The size of the predicted block, called Prediction Unit (PU), is determined by the Coding Unit (CU) size and its partitioning mode. For example, a  $32 \times 32$  CU with  $2N \times N$  partitioning is split into two PUs of size  $32 \times 16$ , or a  $16 \times 16$  CU with  $nL \times 2N$  partitioning is split into  $4 \times 16$  and  $12 \times 16$  PUs.

Mehul Tikekar, *et al.*, *Decoder Hardware Architecture for HEVC*, HIGH EFFICIENCY VIDEO CODING (HEVC) (Vivienne Sze, Madhukar Budagavi, and Gary J. Sullivan (Editors)) (September 2014).

152. Further, the following diagram shows how the Amazon Products receive video data encoded using inter-frame prediction. Specifically, interframe prediction generates a motion vector based on the motion estimation across a first and second frame.

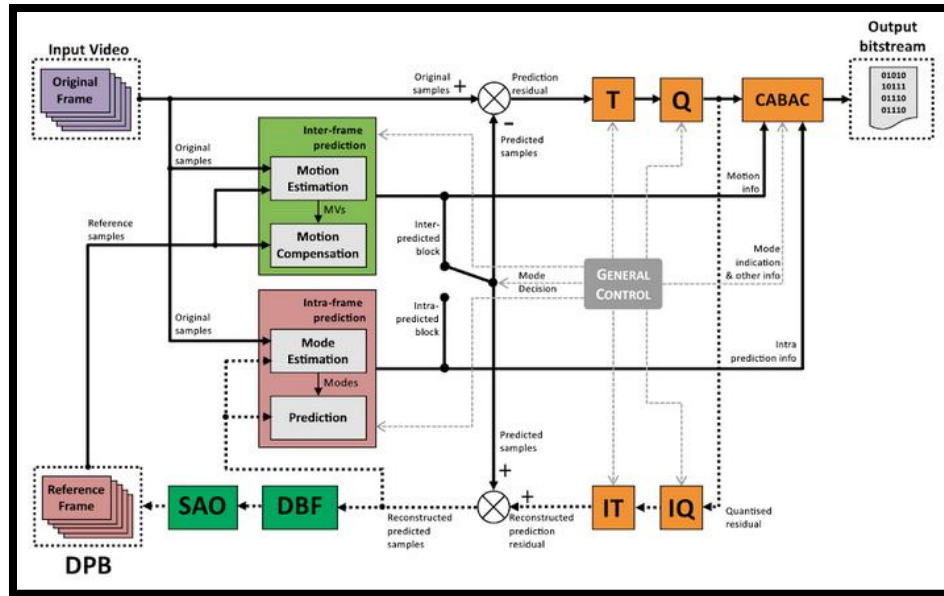

Guilherme Corrêa, *et al.*, COMPLEXITY-AWARE HIGH EFFICIENCY VIDEO CODING at 16 (2015).

153. On information and belief, any implementation of the HEVC standard would infringe the '073 patent as every possible implementation of the standard requires: receiving a video stream containing encoded frame based video information (including both an encoded first frame and an encoded second frame); the encoded second frame that is received depends on the encoding of the first frame, the encoding of the second frame includes motion vectors indicating differences in positions between regions of the second frame and corresponding regions of the first frame; the motion vectors define correspondence between regions of the second frame and corresponding regions of the first frame; decoding the video stream by recovering the motion vectors in the second stream; and determining a re-mapping strategy for the video enhancement of the decoded first frame using a region-based analysis where the first frame is remapped using a remapping strategy and at least one region of the second frame is remapped depending on the re-mapping strategy for corresponding regions of the first frame.

154. On information and belief, the Amazon '073 Products use of sample adaptive offset is a region-based luma analysis that is applied to the decoded first frame (reference picture). "The

SAO reduces sample distortion by first classifying the samples in the region into multiple categories with as selected classifier and adding a specific offset to each sample depending on its category. The classifier index and the offsets for each region are signaled in the bitstream.” Andrey Norkin, Chih-Ming Fu, Yu-Wen Huang, and Shawmin Lei, *In-Loop Filters In HEVC*, IN HIGH EFFICIENCY VIDEO CODING (HEVC) (Vivienne Sze, Madhukar Budagavi, and Gary J. Sullivan (Editors)) at 185 (September 2014) (emphasis added).

155. Further, the HEVC documentation requires that the application of a sample adaptive offset be region based (*e.g.*, applied to a coding block) (“This process is performed on a coding block basis after the completion of the deblocking filter process for the decoded picture”).

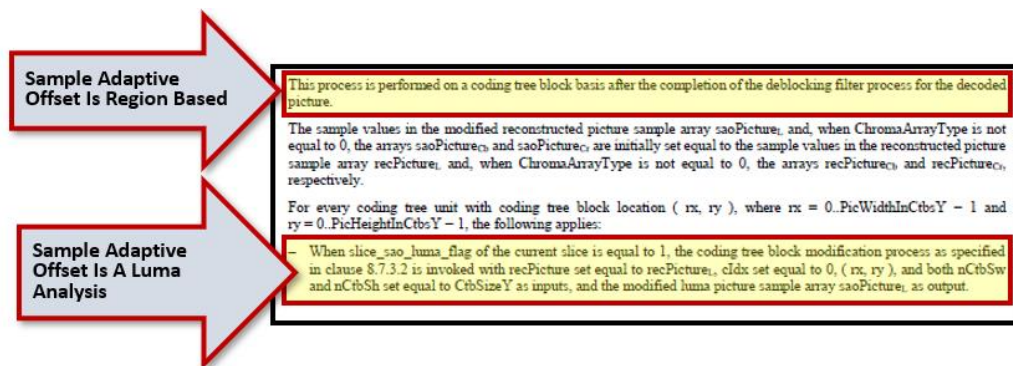

*High Efficiency Video Coding, SERIES H: AUDIOVISUAL AND MULTIMEDIA SYSTEMS: INFRASTRUCTURE OF AUDIOVISUAL SERVICES – CODING OF MOVING VIDEO REC. ITU-T H.265 at § 8.7.3.1 (April 2015) (annotations added).*

156. On information and belief, the Amazon ‘073 Products contain functionality wherein a decoder applies sample adaptive offset to a decoded reference frame (first frame). Further, the Amazon ‘073 Products apply the sample adaptive offset functions to remap a portion of the region based on luminance values (luma). “SAO can be applied to not only luma but also chroma.” Chih-Ming Fu, *et al.*, Sample Adaptive Offset in the HEVC Standard, IEEE TRANSACTIONS ON CIRCUITS AND SYSTEMS FOR VIDEO TECHNOLOGY, VOL. 22, NO. 12 AT 1765 (December 2012).

157. On information and belief, the Amazon ‘073 Products apply the sample adaptive offset to a coding tree unit (region in the first frame), a luminance analysis is performed using two luminance analysis techniques: Edge Offset (“EO”) and Band Offset (“BO”). Edge Offset “uses four 1-D directional patterns for sample classification: horizontal, vertical, 135° diagonal, and 45° diagonal.” Chih-Ming Fu, *et al.*, Sample Adaptive Offset in the HEVC Standard, IEEE TRANSACTIONS ON CIRCUITS AND SYSTEMS FOR VIDEO TECHNOLOGY, VOL. 22, NO. 12 AT 1757 (December 2012). Band Offset “implies one offset is added to all samples of the same band. The sample value range is equally divided into 32 bands.” *Id.* at 1757. The below diagram shows that the Amazon ‘073 Products use different sample adaptive offsets in a region of the first frame in conducting a luminance analysis.

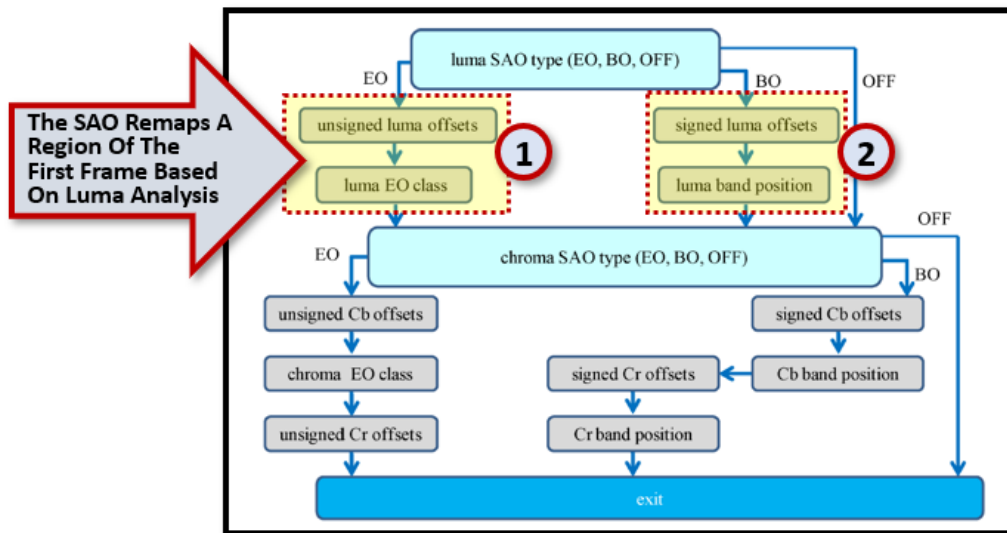

Chih-Ming Fu, *et al.*, Sample Adaptive Offset in the HEVC Standard, IEEE TRANSACTIONS ON CIRCUITS AND SYSTEMS FOR VIDEO TECHNOLOGY, VOL. 22, NO. 12 AT 1759 (December 2012) (annotations added showing (1) edge offset and (2) band offset luma analysis).

158. Further, HEVC documentation makes clear that the application of the standard adaptive offset remapping policy is based on a luminance analysis. The below shows that slices of a region have a standard adaptive offset applied based on a “luma flag.”

<code>if( sample_adaptive_offset_enabled_flag ) {</code>	
<code>  slice_sao_luma_flag</code>	<code>u(1)</code>
<code>  if( ChromaArrayType != 0 )</code>	
<code>    slice_sao_chroma_flag</code>	<code>u(1)</code>

*High Efficiency Video Coding, SERIES H: AUDIOVISUAL AND MULTIMEDIA SYSTEMS: INFRASTRUCTURE OF AUDIOVISUAL SERVICES – CODING OF MOVING VIDEO REC. ITU-T H.265 at § F.7.3.6.1 (April 2015)* (“sample\_adaptive\_offset\_enabled\_flag equal to 1 specifies that the sample adaptive offset process is applied to the reconstructed picture after the deblocking filter process.”).

159. Commentary on the use of sample adaptive offset functionality in decoding HEVC video further confirms that the use of Sample Adaptive Offset (such as that implemented by the Amazon ‘073 Products) is region based and remaps pixel values in a region of a frame by modifying pixels based on an offset value. “[A]fter the deblocking filter through a look-up table . . . [and applying] a certain offset value from a look-up-table is added to the sample.”<sup>22</sup>

**• Sample adaptive offset (SAO)**

- SAO is a process which modifies the samples after the deblocking filter through a look-up table. (non-linear)
- Depending on the local gradient at the sample position, a certain offset value from a look-up table is added to the sample.
- Found to be **efficient** to suppress pseudo-edges referred to as “banding artifacts” and “ringing artifacts”, etc.
- **Performed on a region basis, adapted per LCU.**

- `sao_type_idx=0`, SAO is not applied; `sao_type_idx=1`, band offset types.
- `Sao_type_idx=2`, edge offset types.
  - ✓ `Sao_eo_class = 1..4` to indicate the which directional gradients is used in the edge offset types.

SAO Remaps A Frame Region

SAO Is Region Based

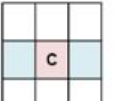

(a) 1-D 0-degree

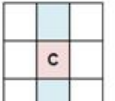

(b) 1-D 90-degree

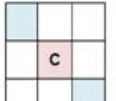

(c) 1-D 135-degree

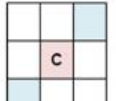

(d) 1-D 45-

Oscar C. Au, HIGH EFFICIENCY VIDEO CODING (HEVC) PRESENTATION at 43 (October 2013) (annotations added).

<sup>22</sup> Oscar C. Au, HIGH EFFICIENCY VIDEO CODING (HEVC) PRESENTATION at 43 (October 2013).

160. On information and belief, when the Amazon ‘073 Products decode a second frame, the application of the remapping policy (sample adaptive offset) will be determined based on the application of sample adaptive offset to the first frame (reference picture). Thus, the application of the remapping policy (sample adaptive offset) to the first frame has the effect of increasing the quality of the reference picture such that the second frame might no longer require the application of sample adaptive offset (remapping policy).<sup>23</sup>

The second in-loop filter, SAO, is applied to the output of the deblocking filter and further improves the quality of the decoded picture by attenuating ringing artifacts and changes in sample intensity of some areas of a picture. The most important advantage of the in-loop filters is improved subjective quality of reconstructed pictures. In addition, using the filters in the decoding loop also increases the quality of the reference pictures and hence also the compression efficiency.

Andrey Norkin, Chih-Ming Fu, Yu-Wen Huang, and Shawmin Lei, *In-Loop Filters In HEVC*, IN HIGH EFFICIENCY VIDEO CODING (HEVC) (Vivienne Sze, Madhukar Budagavi, and Gary J. Sullivan (Editors)) at 171 (September 2014) (annotations added).

161. Further, sample adaptive offset is a policy that remaps the values of pixels. If sample adaptive offset is applied to a reference frame, regions in a second frame might not require the application of the remapping policy as the reference frame that was used to generate the second frame was of a better quality.

SAO classifies each pixel into one of four bands or one of four edge types and adds an offset to it. For band offsets, the band of each pixel depends on its value and the position of the four bands. For edge offsets, the edge of each pixel depends on the whether its value is larger or smaller than two of its neighbors. The selection between band offsets and edge offsets, position of bands, choice of neighbors for edge offsets, and values of the offsets are signaled at the CTU level for luma and chroma separately.

---

<sup>23</sup> Andrey Norkin, Chih-Ming Fu, Yu-Wen Huang, and Shawmin Lei, *In-Loop Filters In HEVC*, IN HIGH EFFICIENCY VIDEO CODING (HEVC) (Vivienne Sze, Madhukar Budagavi, and Gary J. Sullivan (Editors)) at 171 (September 2014) (“HEVC defines two in-loop filters, deblocking and sample adaptive offset (SAO), which significantly improve the subjective quality of decoded video sequences as well as compression efficiency by increasing the quality of the reconstructed/reference pictures.”).



Mehul Tikekar, *et al.*, *Decoder Hardware Architecture for HEVC*, HIGH EFFICIENCY VIDEO CODING (HEVC) (Vivienne Sze, Madhukar Budagavi, and Gary J. Sullivan (Editors)) at 335 (September 2014).

162. The following excerpt from a presentation describing HEVC decoding provides details on how the application of sample adaptive offset remaps pixel values by adding an offset to the pixel value based on a luma analysis.

**SAO Remapping Policy Changes Pixel Values**

**Sample adaptive offset (SAO)**

- For a specified EO type, decoder derives for each pixel which category it belongs to, and then add the received offset of the category to the pixel
  - 4 offsets are sent to decoder for categories 1-4
  - Offset value should be  $\geq 0$  for category 1 & 2, and  $\leq 0$  for category 3 & 4.

Category	Condition
1	$c < 2$ neighboring pixel values
2	$c < 1$ neighbor && $c == 1$ neighbor
3	$c > 1$ neighbor && $c == 1$ neighbor
4	$c > 2$ neighbors
0	None of the above

Oscar C. Au, HIGH EFFICIENCY VIDEO CODING (HEVC) PRESENTATION at 44 (October 2013) (annotation added).

163. Further, the below diagram describing the process wherein HEVC video is decoded shows that sample adaptive offset is applied before the reference frames are stored in the “decoded picture buffer.” Thus, the reference frames stored in the decoded picture buffer have the remapping policy applied to them, and thus when a second frame is decoded, the second frame incorporates the reference frame such that the application of the remapping policy (sample adaptive offset) to the second frame will be based on the application of the remapping policy to the first frame.



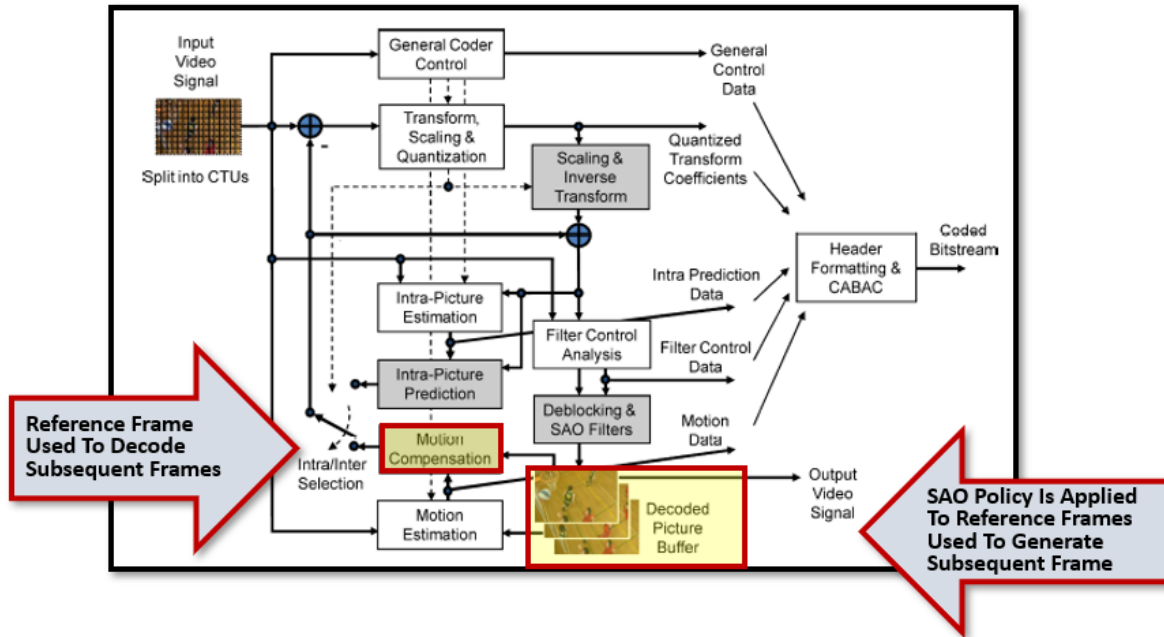

G. J. Sullivan, J.-R. Ohm, W.-J. Han, and T. Wiegand, *Overview of the High Efficiency Video Coding (HEVC) standard*, IEEE TRANS. CIRCUITS SYST. VIDEO TECHNOL., Vol. 22, No. 12 at 1651 (December 2012) (annotations added).

164. The Amazon '073 Products receive encoded video data wherein the second frame includes a region encoding a motion vector difference in position between the region corresponding to the second frame indicating the first frame, the motion vector defines a region between the frame and the second frame corresponding to the first region the correspondence relationship. Specifically, the encoded video data received by the Amazon '073 Products use a translational motion model wherein the position of the block in a previously decoded picture is indicated by a motion vector:  $\Delta x$ ;  $\Delta y$  where  $\Delta x$  specifies the horizontal and  $\Delta y$  the vertical displacement relative to the position of the current block. The motion vectors:  $\Delta x$  and  $\Delta y$  are of fractional sample accuracy to more accurately capture the movement of the underlying object. Interpolation is applied on the reference pictures to derive the prediction signal when the corresponding motion vector has fractional sample accuracy. The previously decoded picture is referred to as the reference picture and indicated by a reference index  $\Delta t$  to a reference picture list.

These translational motion model parameters, *i.e.*, motion vectors and reference indices, are further referred to as motion data. Two kinds of inter-picture prediction are allowed in modern video coding standards, namely uni-prediction and bi-prediction.

HEVC introduces a so-called merge mode, which sets all motion parameters of an inter picture predicted block equal to the parameters of a merge candidate [6]. The merge mode and the motion vector prediction process optionally allow a picture to reuse motion vectors of prior pictures for motion vector coding.

Frank Bossen, et al., *HEVC Complexity and Implementation Analysis*, IEEE TRANSACTIONS ON CIRCUITS AND SYSTEMS FOR VIDEO TECHNOLOGY VOL. 22 NO. 12 at 1686 (December (2012)).

165. On information and belief, one or more of the Amazon '073 Products enable the provision of enhanced video pictures with minimal additional hardware costs for the components required to successfully process the video data.

166. On information and belief, one or more of the Amazon '073 Products include an input for receiving a video stream containing encoded frame-based video information including an encoded first frame and an encoded second frame.

**2.2 Parallel De-Blocking**

HEVC has already adopted the frame-based filtering process proposed by Sony Corporation [14]. On this condition, the horizontal filtering is performed firstly to all the LCUs in the processing picture, and then the vertical filtering is performed to all the LCUs later, which is also called frame-based processing. In H.264/AVC, the

Ming-Ting Sun, et al., *Advances in Multimedia Information Processing*, PCM 2012: 13TH PACIFIC-RIM CONFERENCE ON MULTIMEDIA PROCEEDINGS VOLUME 7674 at 274 (December 4-6, 2012) (“HEVC has already adopted the frame-based filtering process proposed by Sony Corporation.”).

167. On information and belief, one or more of the Amazon '073 Products include a video decoder comprising an input for receiving video information wherein the encoding of the second frame depends on the encoding of the first frame, the encoding of the second frame includes motion vectors indicating differences in positions between regions of the second frame and

corresponding regions of the first frame, the motion vectors define correspondence between regions of the second frame and corresponding regions of the first frame. The Overview of Design Characteristics for HEVC encoded video data describes the use of “motion vectors for block-based inter prediction to exploit temporal statistical dependencies between frames.”

compression. Encoding algorithms (not specified in this Recommendation | International Standard) may select between inter and intra coding for block-shaped regions of each picture. Inter coding uses motion vectors for block-based inter prediction to exploit temporal statistical dependencies between different pictures. Intra coding uses various spatial prediction modes to exploit spatial statistical dependencies in the source signal for a single picture. Motion vectors and intra prediction modes may be specified for a variety of block sizes in the picture. The prediction residual may then be further compressed using a transform to remove spatial correlation inside the transform block before it is quantized, producing a possibly irreversible process that typically discards less important visual information while forming a close approximation to the source samples. Finally, the motion vectors or intra prediction modes may also be further compressed using a variety of prediction mechanisms, and, after prediction, are combined with the quantized transform coefficient information and encoded using arithmetic coding.

*High Efficiency Video Coding, SERIES H: AUDIOVISUAL AND MULTIMEDIA SYSTEMS: INFRASTRUCTURE OF AUDIOVISUAL SERVICES – CODING OF MOVING VIDEO REC. ITU-T H.265 at § 0.7 (April 2015) (annotation added).*

168. On information and belief, one or more of the Amazon ‘073 Products include a video decoder comprising a decoding unit for decoding the frames, wherein the decoding unit recovers the motion vectors for the second frame. Further, HEVC documentation shows that “motion vectors are used during the decoding process for prediction units in inter prediction mode.”

**The Decoder Uses Motion Vectors Based On Inter Prediction**

The decoding process for prediction units in inter prediction mode consists of the following ordered steps:

1. The derivation process for motion vector components and reference indices as specified in clause 8.5.3.2 is invoked with the luma coding block location ( xCb, yCb ), the luma prediction block location ( xBl, yBl ), the luma coding block size block nCbS, the luma prediction block width nPbW, the luma prediction block height nPbH and the prediction unit index partIdx as inputs, and the luma motion vectors mvL0 and mvL1, when ChromaArrayType is not equal to 0, the chroma motion vectors mvCL0 and mvCL1, the reference indices refIdxL0 and refIdxL1 and the prediction list utilization flags predFlagL0 and predFlagL1 as outputs.
2. The decoding process for inter sample prediction as specified in clause 8.5.3.3 is invoked with the luma coding block location ( xCb, yCb ), the luma prediction block location ( xBl, yBl ), the luma coding block size block nCbS, the luma prediction block width nPbW, the luma prediction block height nPbH, the luma motion vectors mvL0 and mvL1, when ChromaArrayType is not equal to 0, the chroma motion vectors mvCL0 and mvCL1, the reference indices refIdxL0 and refIdxL1, and the prediction list utilization flags predFlagL0 and predFlagL1 as inputs, and the inter prediction samples (predSamples) that are an (nCbS<sub>i</sub>)(nCbS<sub>i</sub>) array predSamples<sub>i</sub> of prediction luma samples and, when ChromaArrayType is not equal to 0, two (nCbSw<sub>c</sub>)(nCbSh<sub>c</sub>) arrays predSamples<sub>c<sub>0</sub></sub> and predSamples<sub>c<sub>1</sub></sub> of prediction chroma samples, one for each of the chroma components Cb and Cr, as outputs.

*High Efficiency Video Coding, SERIES H: AUDIOVISUAL AND MULTIMEDIA SYSTEMS: INFRASTRUCTURE OF AUDIOVISUAL SERVICES – CODING OF MOVING VIDEO REC. ITU-T H.265 at § 8.5.3.1 (April 2015) (annotation added).*

169. On information and belief, one or more of the Amazon ‘073 Products include a video decoder comprising a processing component configured to determine a re-mapping strategy for video enhancement of the decoded first frame using a region-based analysis, re-map the first frame using the re-mapping strategy, and re-map one or more regions of the second frame depending on the re-mapping strategy for corresponding regions of the first frame.

170. Further, documentation of the HEVC video decoding process shows that to decode video, the Amazon ‘073 Products use a decoding unit for decoding frames where the Amazon ‘073 Products recover the motion vectors for a second frame. Specifically, the Amazon ‘073 Products use reference pictures (which are also referred to as “I-Frames” or the “previously decoded picture”) and subsequent frames/pictures to generate motion vectors. This method of generating motion vectors for a second frame based on a first frame is referred to as a “translational motion model.”

Using a translational motion model, the position of the block in a previously decoded picture is indicated by a motion vector:  $\Delta x$ ;  $\Delta y$  where  $\Delta x$  specifies the horizontal and  $\Delta y$  the vertical displacement relative to the position of the current block. The motion vectors:  $\Delta x$ ;  $\Delta y$  could be of fractional sample accuracy to more accurately capture the movement of the underlying object. Interpolation is applied on the reference pictures to derive the prediction signal when the corresponding motion vector has fractional sample accuracy. The previously decoded picture is referred to as the reference picture and indicated by a reference index  $\Delta t$  to a reference picture list. These translational motion model parameters, i.e. motion vectors and reference indices, are further referred to as motion data.

Benjamin Bross, *Inter-Picture Prediction In HEVC*, IN HIGH EFFICIENCY VIDEO CODING (HEVC) (Vivienne Sze, Madhukar Budagavi, and Gary J. Sullivan (Editors)) at 114 (September 2014) (emphasis added).

171. On information and belief, the Amazon ‘073 Products contain a decoder (“Decoding Unit”) that uses HEVC inter prediction, which identifies “motion vectors pointing to

one reference frame (uni-prediction) or two reference frames (bi-prediction) to predict a block of pixels.”<sup>24</sup>

Each interpicture-predicted PB is assigned one or two motion vectors and reference picture indices. To minimize worst-case memory bandwidth, PBs of luma size 4×4 are not allowed for interpicture prediction, and PBs of luma sizes 4×8 and 8×4 are restricted to unipredictive coding. The interpicture prediction process is further described as follows.

G. J. Sullivan, J.-R. Ohm, W.-J. Han, and T. Wiegand, *Overview of the High Efficiency Video Coding (HEVC) Standard*, IEEE TRANS. CIRCUITS SYST. VIDEO TECHNOL., vol. 22, no. 12, p. 1654 (December 2012) (emphasis added).

172. On information and belief, the Amazon ‘073 Products are available to businesses and individuals throughout the United States.

173. On information and belief, the Amazon ‘073 Products are provided to businesses and individuals located in the Eastern District of Texas.

174. By making, using, testing, offering for sale, and/or selling products and services for enhancing subsequent images of a video stream in which frames are encoded based on previous frames using prediction and motion estimation, including but not limited to the Amazon ‘073 Products, Amazon has injured Dynamic Data and is liable to the Plaintiff for directly infringing one or more claims of the ‘073 patent, including at least claim 14 pursuant to 35 U.S.C. § 271(a).

175. On information and belief, Amazon also indirectly infringes the ‘073 patent by actively inducing infringement under 35 U.S.C. § 271(b).

176. Amazon has had knowledge of the ‘073 patent since at least service of the Original Complaint in this case or shortly thereafter, and on information and belief, Amazon knew of the ‘073 patent and knew of its infringement, including by way of this lawsuit.

---

<sup>24</sup> Mehul Tikekar, *et al.*, *Decoder Hardware Architecture for HEVC*, HIGH EFFICIENCY VIDEO CODING (HEVC) (Vivienne Sze, Madhukar Budagavi, and Gary J. Sullivan (Editors)) at 316 (September 2014).

177. On information and belief, Amazon intended to induce patent infringement by third-party customers and users of the Amazon '073 Products and had knowledge that the inducing acts would cause infringement or was willfully blind to the possibility that its inducing acts would cause infringement. Amazon specifically intended and was aware that the normal and customary use of the accused products would infringe the '073 patent. Amazon performed the acts that constitute induced infringement, and would induce actual infringement, with knowledge of the '073 patent and with the knowledge that the induced acts would constitute infringement. For example, Amazon provides the Amazon '073 Products that have the capability of operating in a manner that infringe one or more of the claims of the '073 patent, including at least claim 14, and Amazon further provides documentation and training materials that cause customers and end users of the Amazon '073 Products to utilize the products in a manner that directly infringe one or more claims of the '073 patent.<sup>25</sup> By providing instruction and training to customers and end-users on how to use the Amazon '073 Products in a manner that directly infringes one or more claims of the '073 patent, including at least claim 14, Amazon specifically intended to induce infringement of the '073 patent. On information and belief, Amazon engaged in such inducement to promote the sales of the Amazon '073 Products, e.g., through Amazon user manuals, product support, marketing materials, and training materials to actively induce the users of the accused products to infringe the '073 patent. Accordingly, Amazon has induced and continues to induce users of the

---

<sup>25</sup> See, e.g., *Amazon Elastic Transcoder*, DEVELOPER GUIDE API VERSION 2012-09-25 (Nov. 17, 2016); *Amazon Web Services*, GENERAL REFERENCE VERSION 1.0 (2018); Lee Atkinson, *Delivering Media & Entertainment using the AWS Cloud*, AWS TRANSFORMATION DAY GERMANY PRESENTATION (Oct. 25, 2017); *Fire TV Stick*, AMAZON USER GUIDE; *Watching Video in 4K Ultra HD on Fire TV*, AMAZON HELP WEBSITE, available at: <https://www.amazon.com/gp/help/customer/display.html?nodeId=201859000> (last visited Nov. 2018); *Amazon Fire TV*, AMAZON USER GUIDE; *Amazon Fire Tablet and Kindle E-Reader Quick Setup Guide*, AMAZON USER GUIDE (2014); *Fire & Kindle User's Guides*, Amazon Help Website, available at: <https://www.amazon.com/gp/help/customer/display.html?nodeId=200317150> (last visited Nov. 2018).

accused products to use the accused products in their ordinary and customary way to infringe the '073 patent, knowing that such use constitutes infringement of the '073 patent.

178. The '073 patent is well-known within the industry as demonstrated by multiple citations to the '073 patent in published patents and patent applications assigned to technology companies and academic institutions. Amazon is utilizing the technology claimed in the '073 patent without paying a reasonable royalty. Amazon is infringing the '073 patent in a manner best described as willful, wanton, malicious, in bad faith, deliberate, consciously wrongful, flagrant, or characteristic of a pirate.

179. To the extent applicable, the requirements of 35 U.S.C. § 287(a) have been met with respect to the '073 patent.

180. As a result of Amazon's infringement of the '073 patent, Dynamic Data has suffered monetary damages, and seeks recovery in an amount adequate to compensate for Amazon's infringement, but in no event less than a reasonable royalty for the use made of the invention by Amazon together with interest and costs as fixed by the Court.

**COUNT II**  
**INFRINGEMENT OF U.S. PATENT NO. 8,073,054**

181. Dynamic Data references and incorporates by reference the preceding paragraphs of this Complaint as if fully set forth herein.

182. Amazon designs, makes, uses, sells, and/or offers for sale in the United States products and/or services for estimating a current motion vector for a group of pixels of an image.

183. Amazon designs, makes, sells, offers to sell, imports, and/or uses Amazon products that comply with the H.265 standard. By way of example, the following Amazon Products perform encoding pursuant to the H.265 standard: the Amazon Web Services platform (e.g., AWS

Elemental MediaConvert, AWS Elemental MediaLive, Amazon EC2 Accelerated Compute (EC2 G3 Instances), Amazon CloudFront); Amazon Fire TV products (e.g., Fire TV Stick 4k, Fire TV Cube, Fire TV (Gen 3)) (collectively, the “Amazon ‘054A Product(s)”).

184. On information and belief, one or more Amazon subsidiaries and/or affiliates use the Amazon ‘054A Products in regular business operations.

185. On information and belief, Amazon has directly infringed and continues to directly infringe the ‘054A patent by, among other things, making, using, offering for sale, and/or selling technology for estimating a current motion vector for a group of pixels of an image, including but not limited to the Amazon ‘054A Products.

186. The accused Amazon Web Services platform products (e.g., AWS Elemental MediaConvert, AWS Elemental MediaLive, Amazon EC2 Accelerated Compute (EC2 G3 Instances), Amazon CloudFront) comply with the HEVC image processing standard. As shown in the following excerpts from Amazon documentation the accused Amazon Web Services Platform products comply with the HEVC standard.

Until recently, H.264 (also known as AVC) was the best codec for optimizing quality and reducing file sizes; many content publishers still use it today. But it’s quickly giving way to HEVC: High-Efficiency Video Coding. It’s also referred to as H.265; different standards groups employ different designations to refer to the same standard. HEVC requires more computing power than H.264, but it’s more efficient. Because AWS Elemental writes all of its encoding software from scratch, rather than relying on off-the-shelf encoding software, it is able to take the efficiency gains in each new generation of codec and adjust the software accordingly to get the best quality and/ or smallest video file sizes, along with the shortest encoding times.

Alicia Hunt, *A Video Compression Primer*, AWS MEDIA BLOG (January 30, 2019), available at: <https://aws.amazon.com/blogs/media/a-video-compression-primer/> (emphasis added).



**Example 1** | **Example 2**

---

The per hour cost for a live channel with two HD inputs (using input switching) and producing 5 outputs with advanced audio in the US East (N. Virginia) Region:

**Input**  
 1080p HD, HEVC, 20Mbps = \$0.600 per hour  
 1080p HD, HEVC, 20Mbps = \$0.600 per hour

*AWS Elemental MediaLive Pricing, AWS DOCUMENTATION, available at: <https://aws.amazon.com/medialive/pricing/>*

**Comprehensive Input and Output Support**  
 Create streams using standard video formats

AWS Elemental MediaConvert supports a broad range of video input and output formats, including those for broadcast as well as formats for delivery over the internet. The service supports the MPEG-2, AVC, Apple ProRes, and HEVC compression standards—including support for advanced color sampling (10-bit 4:2:2). It supports a broad range of adaptive bitrate packaging formats including CMAF, Apple HLS, DASH ISO, and Microsoft Smooth Streaming. AWS Elemental MediaConvert also supports processing and conversion of 4K resolution and high dynamic range (HDR) video content.

*AWS Elemental MediaConvert, AWS DOCUMENTATION, available at: <https://aws.amazon.com/mediaconvert/features/> (AWS Elemental MediaConvert supports a broad range of video input and output formats . . . [t]he service supports . . . HEVC compression standards.”).*

Amazon EC2 G3 instances are the latest generation of Amazon EC2 GPU graphics instances that deliver a powerful combination of CPU, host memory, and GPU capacity. G3 instances are ideal for graphics-intensive applications such as 3D visualizations, mid to high-end virtual workstations, virtual application software, 3D rendering, application streaming, video encoding, gaming, and other server-side graphics workloads.

G3 instances provides access to NVIDIA Tesla M60 GPUs, each with up to 2,048 parallel processing cores, 8 GiB of GPU memory, and a hardware encoder supporting up to 10 H.265 (HEVC) 1080p30 streams and up to 18 H.264 1080p30 streams. With the latest driver releases, these GPUs provide support for OpenGL, DirectX, CUDA, OpenCL, and Capture SDK (formerly known as GRID SDK).

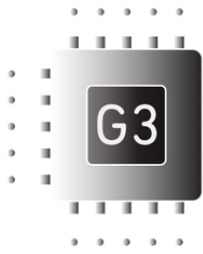

*Amazon EC2 G3 Instances, AWS DOCUMENTATION, available at: <https://aws.amazon.com/ec2/instance-types/g3/> (“G3 instances provides access to NVIDIA Tesla M60 GPUs, each with up to 2,048 parallel processing cores, 8 GiB of GPU memory, and a hardware encoder supporting up to 10 H.265 (HEVC) 1080p30 streams and up to 18 H.264 1080p30 streams.”).*

187. The accused Amazon Fire TV Products (e.g., Fire TV Stick 4k, Fire TV Cube, and Fire TV (Gen 3)) comply with the HEVC image processing standard. The below excerpt from

Amazon Fire TV Developer documentation describes the accused Amazon Fire TV Products as complying with the requirements of the HEVC standard.

Fire TV Stick 4K			
Type	Codec	MIME type	Details
<b>Video</b>	H.265 (HEVC) (High Efficiency Video Coding)	video/hevc	Hardware accelerated up to 3840x2160p (4K) @ 60fps, 35 Mbps, Main 10 Profile Level 5.1, Color space 8-bit and 10-bit input with HDR10, HDR10+, HLG, and Dolby Vision support in rendering pipelines.

*Device Specifications for Fire TV*, AMAZON DEVELOPER DOCUMENTATION, available at: <https://developer.amazon.com/docs/fire-tv/device-specifications.html> (describing the HEVC encoding and decoding support for the Amazon Fire TV Products).

188. On information and belief, by complying with the HEVC standard, Amazon’s devices – such as the Amazon ‘054A Products – necessarily infringe the ‘054A patent. Mandatory sections of the HEVC standard require the elements required by certain claims of the ‘054A patent, including but not limited to claim 1. *High Efficiency Video Coding*, SERIES H: AUDIOVISUAL AND Multimedia SYSTEMS: INFRASTRUCTURE OF AUDIOVISUAL SERVICES – CODING OF MOVING VIDEO REC. ITU-T H.265 (February 2018) (The following sections of the HEVC Standard are relevant to Amazon’s infringement of the ‘054A patent: “7.3.4 Scaling list data syntax;” 7.3.6.1 General slice segment header syntax;” “7.3.6.3 Weighted prediction parameters syntax;” “7.3.8.14 Delta QP syntax;” “7.4.4 Profile, tier and level semantics;” and “7.4.7.3 Weighted prediction parameters semantics.”

189. On information and belief, the Amazon ‘054A Products comprise functionality for generating a set of candidate motion vectors for a grouping of pixels (prediction unit). The HEVC standard generates a set of candidate motion vectors for the group of pixels, with the candidate motion vectors being extracted from a set of previously estimated motion vectors. After the candidate motion vectors are generated, only the best candidate index is transmitted.

#### Inter prediction

For motion vector prediction HEVC has two reference lists: L0 and L1. They can hold 16 references each, but the maximum total number of unique pictures is 8. Multiple instances of the same ref frame can be stored with different weights. HEVC motion estimation is much more complex than in AVC. It uses list indexing. There are two main prediction modes: Merge and Advanced MV. Each PU can use one of those methods and can have forward (a MV) or bi-directional prediction (2 MV). In Advanced MV mode a list of candidates MV is created (spatial and temporal candidates picked with a complex, probabilistic logic), when the list is created only the best candidate index is transmitted in the bitstream plus the MV delta (the difference between the real MV and the prediction). On the other side, the decoder will build and update continuously the same candidate list using the exact same rules used by the encoder and will pick-up the MV to use as estimator using the index sent by the encoder in the bitstream. The merge mode is similar, the main difference is that the candidates' list is calculated from neighboring MV and is not added to a delta MV. It is the equivalent of "skip" mode in AVC.

Fabio Sonnati, *H265 – Part I: Technical Overview*, VIDEO ENCODING & STREAMING TECHNOLOGIES WEBSITE (June 20, 2014) (emphasis added).

190. On information and belief, one or more of the Amazon '054A Products enable motion estimation with a relatively fast convergence in finding the appropriate motion vectors of the motion vector fields by adding a further candidate motion vector to the set of candidate motion vectors.

HEVC introduces a so-called merge mode, which sets all motion parameters of an inter picture predicted block equal to the parameters of a merge candidate [6]. The merge mode and the motion vector prediction process optionally allow a picture to reuse motion vectors of prior pictures for motion vector coding,

Frank Bossen, *et al.*, *HEVC Complexity and Implementation Analysis*, IEEE TRANSACTIONS ON CIRCUITS AND SYSTEMS FOR VIDEO TECHNOLOGY VOL. 22 NO. 12 at 1686 (December (2012)).

191. On information and belief, the following block diagram illustrates the form of encoded video data received by the Amazon '054A Products. Specifically, the encoded video data received by the Amazon '054A Products is encoded using inter-picture prediction where the motion data of a block is correlated with neighboring blocks. To exploit this correlation, motion data is not directly coded in the bitstream, but predictively coded based on neighboring motion data. Further, the Amazon '054A Products receive data that is encoded using advanced motion

vector prediction where the best predictor for each motion block is signaled to the decoder. In addition, inter-prediction block merging derives all motion data of a block from the neighboring blocks.

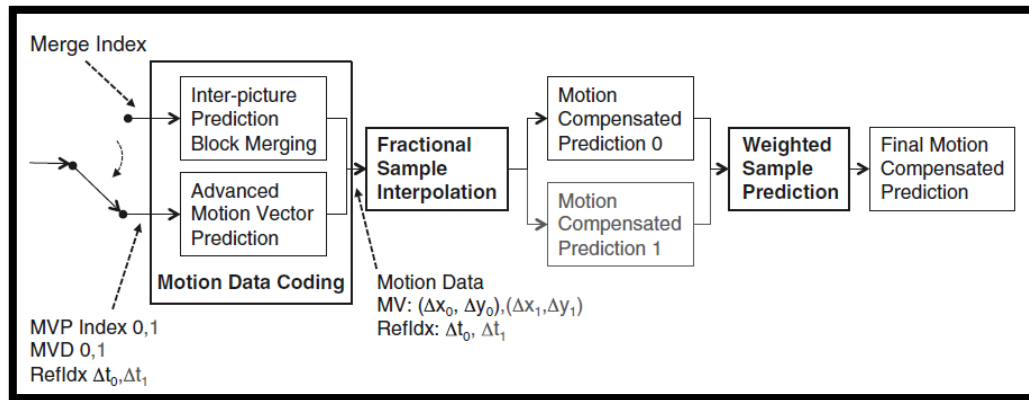

Benjamin Bross, *et al.*, *Inter-Picture Prediction in HEVC*, In HIGH EFFICIENCY VIDEO CODING (HEVC) at 115 (2014).

192. On information and belief, the Amazon '054A Products carry out a block-based motion vector estimation process that involves comparing a plurality of candidate vectors to determine block-based motion vectors. The Amazon '054A Products generate two predictor candidate motion vectors (a spatial motion vector and temporal motion vector). The first predictor candidate motion vector is drawn from a list of spatial motion vector candidates.

three spatially neighboring MVs. HEVC improves the MV prediction by applying an MV prediction competition as initially proposed in [18]. In HEVC, this competition was further adapted to large block sizes with so-called *advanced motion vector prediction* (AMVP) in [19]. In the DIS Main profile, AMVP has two predictor candidates competing for the prediction. Two spatial motion vector predictor (MVP) candidates are considered and, when at least one of them is not available or they are redundant, a temporal motion vector prediction (TMVP) candidate is considered. The candidates

Philipp Helle, Simon Oudin, Benjamin Bross, Detlev Marpe, M. Oguz Bici, Kemal Ugur, Joel Jung, Gordon Clare, and Thomas Wiegand, *Block Merging for Quadtree-Based Partitioning in HEVC*, *IEEE TRANS. CIR. AND SYS. FOR VIDEO TECHNOLOGY*, Vol. 22 No. 12 (December 2012) (“AMVP has two predictor candidates competing for the prediction. Two spatial motion vector

predictor (MVP) candidates are considered and, when at least one of them is not available or they are redundant, a temporal motion vector prediction (TMVP) candidate is considered.”).

193. On information and belief, one or more of the Amazon ‘054A Products include a motion estimation unit comprising a generating unit for generating a set of candidate motion vectors for the group of pixels, with the candidate motion vectors being extracted from a set of previously estimated motion vectors.

194. On information and belief, the Amazon ‘054A Products contain functionality for generating match errors of the respective candidate motion vectors. The HEVC standard calculates match errors of respective candidate motion vectors. The match errors are in some commentary on the HEVC standard as the MV delta. The MV delta is the difference between the real MV and the candidate predication.

**Inter prediction**

For motion vector prediction HEVC has two reference lists: L0 and L1. They can hold 16 references each, but the maximum total number of unique pictures is 8. Multiple instances of the same ref frame can be stored with different weights. HEVC motion estimation is much more complex than in AVC. It uses list indexing. There are two main prediction modes: Merge and Advanced MV. Each PU can use one of those methods and can have forward (a MV) or bi-directional prediction (2 MV). In Advanced MV mode a list of candidates MV is created (spatial and temporal candidates picked with a complex, probabilistic logic), when the list is created only the best candidate index is transmitted in the bitstream plus the MV delta (the difference between the real MV and the prediction). On the other side, the decoder will build and update continuously the same candidate list using the exact same rules used by the encoder and will pick-up the MV to use as estimator using the index sent by the encoder in the bitstream. The merge mode is similar, the main difference is that the candidates’ list is calculated from neighboring MV and is not added to a delta MV. It is the equivalent of “skip” mode in AVC.

Fabio Sonnati, *H265 – Part I: Technical Overview*, VIDEO ENCODING & STREAMING TECHNOLOGIES WEBSITE (June 20, 2014) (emphasis added).

195. On information and belief, any implementation of the HEVC standard would infringe the ‘054A patent as every implementation of the standard requires the elements in one or more claims of the ‘054A patent, including but not limited to claim 1, by way of example: a match error unit for calculating match errors of respective candidate motion vectors and calculating the

further candidate motion vector by means of calculating a difference between the second motion vector and the first motion vector.

196. On information and belief, one or more of the Amazon '054A Products include a motion estimation unit comprising a selector for selecting the current motion vector from the candidate motion vectors by means of comparing the match errors of the respective candidate motion vectors, characterized in that the motion estimation unit is arranged to add a further candidate motion vector to the set of candidate motion vectors by calculating the further candidate motion vector on basis of a first motion vector and a second motion vector, both belonging to the set of previously estimated motion vectors.

197. On information and belief, the Amazon '054A Products select the current motion vector from the candidate motion vectors by comparing the match errors of the respective candidate motion vectors, characterized in that the motion estimation unit is arranged to add a further candidate motion vector to the set of candidate motion vectors by calculating the further candidate motion vector on basis of a first motion vector and a second motion vector, both belonging to the set of previously estimated motion vectors. The first motion vector is labeled 'A' and the second motion vector is labeled 'B'.

#### Spatial Candidates

As already mentioned, two spatial MVP candidates A and B are derived from five spatially neighboring blocks which are shown in Fig. 5.4b. The locations of the spatial candidate blocks are the same for both AMVP and inter-prediction block merging that will be presented in Sect. 5.2.2.

Gary Sullivan, *et al.*, HIGH EFFICIENCY VIDEO CODING (HEVC) ALGORITHMS AND ARCHITECTURES at 117 (2014) (emphasis added).



198. Further, the Amazon ‘054A Products perform motion vector “competition / weighted sample prediction” by comparing the match errors of the candidate motion vectors. The match errors generated by the Amazon ‘054A Products comprise the difference value between the second motion vector and the first motion vector. Documentation of the encoding process states that the encoder will “pick up the MV [motion vector] to use as an estimator using the index sent by the encoder in the bitstream.”

**Inter prediction**

For motion vector prediction HEVC has two reference lists: L0 and L1. They can hold 16 references each, but the maximum total number of unique pictures is 8. Multiple instances of the same ref frame can be stored with different weights. HEVC motion estimation is much more complex than in AVC. It uses list indexing. There are two main prediction modes: Merge and Advanced MV. Each PU can use one of those methods and can have forward (a MV) or bi-directional prediction (2 MV). In Advanced MV mode a list of candidates MV is created (spatial and temporal candidates picked with a complex, probabilistic logic), when the list is created only the best candidate index is transmitted in the bitstream plus the MV delta (the difference between the real MV and the prediction). On the other side, the decoder will build and update continuously the same candidate list using the exact same rules used by the encoder and will pick-up the MV to use as estimator using the index sent by the encoder in the bitstream. The merge mode is similar, the main difference is that the candidates’ list is calculated from neighboring MV and is not added to a delta MV. It is the equivalent of “skip” mode in AVC.

Fabio Sonnati, *H265 – Part I: Technical Overview*, VIDEO ENCODING & STREAMING TECHNOLOGIES WEBSITE (June 20, 2014) (emphasis added).

199. On information and belief, the Amazon ‘054A Products calculate the square of the difference between two corresponding pixels of the spatial position of the candidate block where the motion vector is located and the spatial position where the reference motion vector is located. As a result, this value is used to assess the similarity, or the matching degree, of a candidate block. Thus, in order to obtain the best matching vector, the Amazon ‘054A Products apply a penalty value to every candidate block with a different motion vector ( $MV_x$ ,  $MV_y$ ) within the search window defined by the search range in the reference frame. Finally, a candidate block with the minimum penalty value will be denoted as the best matching block and used to calculate the best motion vector from the candidate motion vectors. The below excerpt from an article discussing

the selection of a best motion vector describes that the selection of a motion vector is based on the position of the motion vector.

The entire ME process is made up of three coarse-to-fine procedures, namely, MV prediction, integer-pixel ME and fractional-pixel ME. First, MV prediction predicts the start search position for the following motion search by utilizing the neighboring motion information. In HEVC, Advanced Motion Vector Prediction (AMVP), a new and effective technology that predicts the starting search position by referencing the motion vector (MV) information of spatial and temporal motion vector candidates, is adopted, which derives several most probable candidates based on data from adjacent PBs and the reference picture. The displacement between the starting search position and the current coding PU is called a predictive motion vector (PMV). HEVC also introduces a merge mode to derive the motion information from spatially or temporally neighboring blocks [1].

Yongfei Zhang, Chao Zhang, and Rui Fan, *Fast Motion Estimation in HEVC Inter Coding: An Overview of Recent Advances*, PROCEEDINGS, APSIPA ANNUAL SUMMIT AND CONFERENCE 2018 at 1 (November 2018) (emphasis added).

200. On information and belief, one or more of the Amazon '054A Products include a motion estimation unit that calculates the further candidate motion vector on basis of the first motion vector and the second motion vector, with the first motion vector belonging to a first forward motion vector field and the second motion vector belonging to a second forward motion vector field, with the first forward motion vector field and the second forward motion vector field being different. Specifically, the HEVC standard arranges to calculate the further candidate motion vector by calculating a difference between the second motion vector and the first motion vector. The further candidate motion vector is calculated at the end of the process diagram below (see the red box).



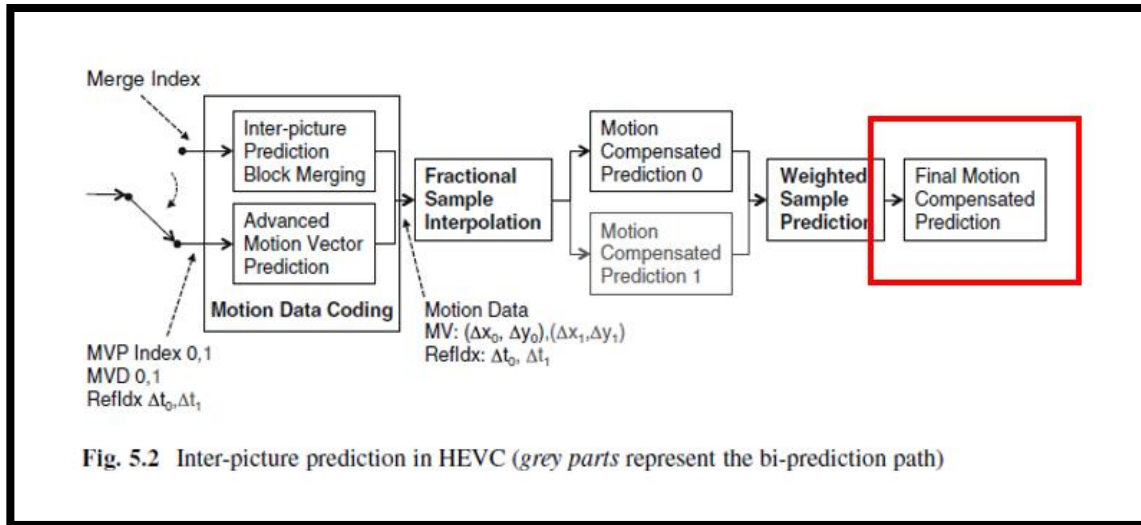

Gary J. Sullivan, *et al.*, HEVC, HIGH EFFICIENCY VIDEO CODING (HEVC) at 115 (September 2014) (emphasis added).

201. On information and belief, the Amazon ‘054A Products are available to businesses and individuals throughout the United States.

202. On information and belief, the Amazon ‘054A Products are provided to businesses and individuals located in the Eastern District of Texas.

203. By making, using, testing, offering for sale, and/or selling products and services for estimating a current motion vector for a group of pixels of an image, including but not limited to the Amazon ‘054A Products, Amazon has injured Dynamic Data and is liable to the Plaintiff for directly infringing one or more claims of the ‘054A patent, including at least claim 1 pursuant to 35 U.S.C. § 271(a).

204. On information and belief, Amazon also indirectly infringes the ‘054A patent by actively inducing infringement under 35 U.S.C. § 271(b).

205. Amazon has had knowledge of the ‘054A patent since at least service of the Original Complaint in this case or shortly thereafter, and on information and belief, Amazon knew of the ‘054A patent and knew of its infringement, including by way of this lawsuit.

206. On information and belief, Amazon intended to induce patent infringement by third-party customers and users of the Amazon '054A Products and had knowledge that the inducing acts would cause infringement or was willfully blind to the possibility that its inducing acts would cause infringement. Amazon specifically intended and was aware that the normal and customary use of the accused products would infringe the '054A patent. Amazon performed the acts that constitute induced infringement, and would induce actual infringement, with knowledge of the '054A patent and with the knowledge that the induced acts would constitute infringement. For example, Amazon provides the Amazon '054A Products that have the capability of operating in a manner that infringe one or more of the claims of the '054A patent, including at least claim 1, and Amazon further provides documentation and training materials that cause customers and end users of the Amazon '054A Products to utilize the products in a manner that directly infringe one or more claims of the '054A patent.<sup>26</sup> By providing instruction and training to customers and end-users on how to use the Amazon '054A Products in a manner that directly infringes one or more claims of the '054A patent, including at least claim 1, Amazon specifically intended to induce infringement of the '054A patent. On information and belief, Amazon engaged in such inducement to promote the sales of the Amazon '054A Products, e.g., through Amazon user manuals, product support, marketing materials, and training materials to actively induce the users of the accused products to infringe the '054A patent. Accordingly, Amazon has induced and continues to induce users of the accused products to use the accused products in their ordinary and

---

<sup>26</sup> See, e.g., *Amazon Elastic Transcoder*, DEVELOPER GUIDE API VERSION 2012-09-25 (Nov. 17, 2016); *Amazon Web Services*, GENERAL REFERENCE VERSION 1.0 (2018); Lee Atkinson, *Delivering Media & Entertainment using the AWS Cloud*, AWS TRANSFORMATION DAY GERMANY PRESENTATION (Oct. 25, 2017); *Fire TV Stick*, AMAZON USER GUIDE; *Watching Video in 4K Ultra HD on Fire TV*, AMAZON HELP WEBSITE, available at: <https://www.amazon.com/gp/help/customer/display.html?nodeId=201859000> (last visited Nov. 2018); *Amazon Fire TV*, AMAZON USER GUIDE.

customary way to infringe the '054A patent, knowing that such use constitutes infringement of the '054A patent.

207. The '054A patent is well-known within the industry as demonstrated by multiple citations to the '054A patent in published patents and patent applications assigned to technology companies and academic institutions. Amazon is utilizing the technology claimed in the '054A patent without paying a reasonable royalty. Amazon is infringing the '054A patent in a manner best described as willful, wanton, malicious, in bad faith, deliberate, consciously wrongful, flagrant, or characteristic of a pirate.

208. To the extent applicable, the requirements of 35 U.S.C. § 287(a) have been met with respect to the '054A patent.

209. As a result of Amazon's infringement of the '054A patent, Dynamic Data has suffered monetary damages, and seeks recovery in an amount adequate to compensate for Amazon's infringement, but in no event less than a reasonable royalty for the use made of the invention by Amazon together with interest and costs as fixed by the Court.

**COUNT III**  
**INFRINGEMENT OF U.S. PATENT NO. 6,774,918**

210. Dynamic Data references and incorporates by reference the preceding paragraphs of this Complaint as if fully set forth herein.

211. Amazon designs, makes, uses, sells, and/or offers for sale in the United States products and/or services for image processing.

212. Amazon designs, makes, sells, offers to sell, imports, and/or uses Amazon products containing H.265-compliant decoding functionality, including but not limited to: the Amazon Web Services platform (e.g., AWS Elastic Transcoder, AWS Elemental MediaConvert, AWS

Elemental MediaLive, Amazon CloudFront); Amazon Fire TV products (e.g., Fire TV Stick 4k, Fire TV Cube, Fire TV (Gen 3), Fire TV (Gen 2), Fire TV Edition - Toshiba 4K (2018), Fire TV Edition - Element 4K (2018), Fire TV Edition - Insignia HD (2018), Fire TV Edition - Insignia 4k (2018), Fire TV Edition - Toshiba HD (2018)); and Amazon Fire Tablet products (e.g., (Fire HD 8 (2018), Fire HD 10 (2017), Fire HD 8 (2017), Fire 7 (2017), Fire HD 8 (2016), Fire (2015), Fire HD 8 (2015), Fire HD 10 (2015), Fire HDX 8.9 (2014), Fire HD 7 (2014), Fire HD 6 (2014), Kindle Fire HDX 8.9 (2013), Kindle Fire HDX (2013), Kindle Fire HD (2013), Kindle Fire HD 8.9 (2012), Kindle Fire HD (2012), Kindle Fire (2012), Kindle Fire (2011)) (collectively, the “Amazon ‘918 Product(s)”).

213. On information and belief, one or more Amazon subsidiaries and/or affiliates use the Amazon ‘918 Products in regular business operations.

214. On information and belief, Amazon has directly infringed and continues to directly infringe the ‘918 patent by, among other things, making, using, offering for sale, and/or selling video processing technology, including but not limited to the Amazon ‘918 Products.

215. The accused Amazon Web Services platform products (e.g., AWS Elastic Transcoder, AWS Elemental MediaConvert, AWS Elemental MediaLive, Amazon EC2 Accelerated Compute (EC2 G3 Instances), and Amazon CloudFront) comply with the HEVC image processing standard. As shown in the following excerpts from Amazon Documentation the accused Amazon Web Services Platform functionalities comply with the HEVC standard.

Until recently, H.264 (also known as AVC) was the best codec for optimizing quality and reducing file sizes; many content publishers still use it today. But it’s quickly giving way to HEVC: High-Efficiency Video Coding. It’s also referred to as H.265; different standards groups employ different designations to refer to the same standard. HEVC requires more computing power than H.264, but it’s more efficient. Because AWS Elemental writes all of its encoding software from scratch, rather than relying on off-the-shelf encoding software, it is able to take the efficiency gains in each new

generation of codec and adjust the software accordingly to get the best quality and/ or smallest video file sizes, along with the shortest encoding times.

Alicia Hunt, *A Video Compression Primer*, AWS MEDIA BLOG (January 30, 2019), available at: <https://aws.amazon.com/blogs/media/a-video-compression-primer/> (emphasis added).

**Example 1** | **Example 2**

---

The per hour cost for a live channel with two HD inputs (using input switching) and producing 5 outputs with advanced audio in the US East (N. Virginia) Region:

**Input**  
1080p HD, HEVC, 20Mbps = \$0.600 per hour  
1080p HD, HEVC, 20Mbps = \$0.600 per hour

*AWS Elemental MediaLive Pricing*, AWS DOCUMENTATION, available at: <https://aws.amazon.com/medialive/pricing/>

**Comprehensive Input and Output Support**  
Create streams using standard video formats

AWS Elemental MediaConvert supports a broad range of video input and output formats, including those for broadcast as well as formats for delivery over the internet. The service supports the MPEG-2, AVC, Apple ProRes, and HEVC compression standards—including support for advanced color sampling (10-bit 4:2:2). It supports a broad range of adaptive bitrate packaging formats including CMAF, Apple HLS, DASH ISO, and Microsoft Smooth Streaming. AWS Elemental MediaConvert also supports processing and conversion of 4K resolution and high dynamic range (HDR) video content.

*AWS Elemental MediaConvert*, AWS DOCUMENTATION, available at: <https://aws.amazon.com/mediaconvert/features/> (AWS Elemental MediaConvert supports a broad range of video input and output formats . . . [t]he service supports . . . HEVC compression standards.”).

Amazon EC2 G3 instances are the latest generation of Amazon EC2 GPU graphics instances that deliver a powerful combination of CPU, host memory, and GPU capacity. G3 instances are ideal for graphics-intensive applications such as 3D visualizations, mid to high-end virtual workstations, virtual application software, 3D rendering, application streaming, video encoding, gaming, and other server-side graphics workloads.

G3 instances provides access to NVIDIA Tesla M60 GPUs, each with up to 2,048 parallel processing cores, 8 GiB of GPU memory, and a hardware encoder supporting up to 10 H.265 (HEVC) 1080p30 streams and up to 18 H.264 1080p30 streams. With the latest driver releases, these GPUs provide support for OpenGL, DirectX, CUDA, OpenCL, and Capture SDK (formerly known as GRID SDK).

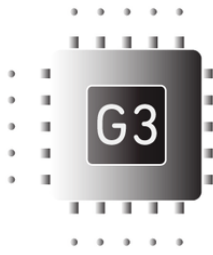

*Amazon EC2 G3 Instances*, AWS DOCUMENTATION, available at: <https://aws.amazon.com/ec2/instance-types/g3/> (“G3 instances provides access to NVIDIA Tesla M60 GPUs, each with up to 2,048 parallel processing cores, 8 GiB of GPU memory, and a

hardware encoder supporting up to 10 H.265 (HEVC) 1080p30 streams and up to 18 H.264 1080p30 streams.”).

216. The accused Amazon Fire TV Products (e.g., Fire TV Stick 4k, Fire TV Cube, Fire TV (Gen 3), Fire TV (Gen 2), Fire TV Edition - Toshiba 4K (2018), Fire TV Edition - Element 4K (2018), Fire TV Edition - Insignia HD (2018), Fire TV Edition - Insignia 4k (2018), Fire TV Edition - Toshiba HD (2018)) comply with the HEVC image processing standard. The below excerpt from Amazon Fire TV Developer documentation describes the accused Amazon Fire TV Products as complying with the requirements of the HEVC standard.

Fire TV Stick 4K			
Type	Codec	MIME type	Details
<b>Video</b>	H.265 (HEVC) (High Efficiency Video Coding)	video/hevc	Hardware accelerated up to 3840x2160p (4K) @ 60fps, 35 Mbps, Main 10 Profile Level 5.1, Color space 8-bit and 10-bit input with HDR10, HDR10+, HLG, and Dolby Vision support in rendering pipelines.

*Device Specifications for Fire TV, AMAZON DEVELOPER DOCUMENTATION, available at: <https://developer.amazon.com/docs/fire-tv/device-specifications.html> (describing the HEVC encoding and decoding support for the Amazon Fire TV Products).*

217. The accused Amazon Fire Tablet Products (e.g., Fire HD 8 (2018), Fire HD 10 (2017), Fire HD 8 (2017), Fire 7 (2017), Fire HD 8 (2016), Fire HD 8 (2015), Fire HD 10 (2015)) comply with the HEVC image processing standard. The below excerpt from Amazon Fire Tablet Developer documentation describes the accused Amazon Fire Tablet Products as complying with the requirements of the HEVC standard.

H.264 AVC	D (HW) High profile, L4.1 1080p@30FPS, E (HW)	D (HW) High profile, L4.1 Main Profile@L4 1080p@30FPS/4 0Mbps, E (HW)	D (HW) High profile, L4.1 Main Profile@L4 1080p@30FPS/4 0Mbps, E (HW)	D (HW) High profile, L4.1 1080p@30FPS, E (HW)
H.265 HEVC	D(HW) Main Profile L4 1080p@30FPS	D (HW) Main Profile L4 Main Profile@L4 1080p@30FPS/4 0Mbps	D (HW) Main Profile L4 Main Profile@L4 1080p@30FPS/4 0Mbps	D(HW) Main Profile L4 1080p@30FPS

*Amazon Fire TV Tablet Media Specifications*, AMAZON DEVELOPER DOCUMENTATION, available at: <https://developer.amazon.com/docs/fire-tablets/ft-media-specs-custom.html> (showing that the Fire HD 8 (2018), Fire HD 10 (2017), Fire HD 8 (2017) and Fire 7 (2017) support H.265 encoding compliant with the standard).

218. On information and belief, the Amazon ‘918 Products use two types of prediction methods for decoding video data: inter prediction and intra prediction. Inter prediction utilizes motion vectors as well as an offset center and creates a list of possible motion vectors (MV) for the search area. The HEVC Specification (*e.g.*, *High Efficiency Video Coding*, SERIES H: AUDIOVISUAL AND MULTIMEDIA SYSTEMS: INFRASTRUCTURE OF AUDIOVISUAL SERVICES – CODING OF MOVING VIDEO REC. ITU-T H.265 (April 2015)) sets forth the standard that is followed by HEVC compliant devices and is relevant to both decoding and encoding that are performed pursuant to the HEVC standard. For instance, the Amazon Products perform a method for decoding a video signal using motion vectors when performing encoding of H.265/HEVC video data. For example, the Amazon Products contain functionality for decoding a video signal using motion vectors and motion estimation.

219. On information and belief, by complying with the HEVC standard, the Amazon devices – such as the Amazon ‘918 Products – necessarily infringe the ‘918 patent. Mandatory sections of the HEVC standard require the elements required by certain claims of the ‘918 patent, including but not limited to claim 18. *High Efficiency Video Coding*, SERIES H: AUDIOVISUAL AND

Multimedia SYSTEMS: INFRASTRUCTURE OF AUDIOVISUAL SERVICES – CODING OF MOVING VIDEO REC. ITU-T H.265 (February 2018). The following sections of the HEVC Standard are relevant to Amazon’s infringement of the ‘918 patent: “5.3 Logical operators;” “5.10 Variables, syntax elements and tables;” “5.11 Text description of logical operations;” “7.2 Specification of syntax functions and descriptors;” “7.3.1 NAL unit syntax;” “7.3.2 Raw byte sequence payloads, trailing bits and byte alignment syntax;” “7.3.5 Supplemental enhancement information message syntax;” “7.4.2 NAL unit semantics;” and “7.4.6 Supplemental enhancement information message semantics.”

220. On information and belief, the Amazon ‘918 Products receive a bitstream in which the data is segmented into Network Abstraction Layer (“NAL”) Units. NAL Units are segments of data that can include video data and overlay data (such as captions and overlay images). The Amazon Products support the receipt of VCL and non-VCL NAL units. The VCL NAL units contain the data that represents the values of the samples in the video pictures, and the non-VCL NAL units contain any associated additional information such as parameter sets or overlay data.

HEVC uses a NAL unit based bitstream structure. A coded bitstream is partitioned into NAL units which, when conveyed over lossy packet networks, should be smaller than the maximum transfer unit (MTU) size. Each NAL unit consists of a NAL unit header followed by the NAL unit payload. There are two conceptual classes of NAL units. Video coding layer (VCL) NAL units containing coded sample data, e.g., coded slice NAL units, whereas non-VCL NAL units that contain metadata typically belonging to more than one coded picture, or where the association with a single coded picture would be meaningless, such as parameter set NAL units, or where the information is not needed by the decoding process, such as SEI NAL units.

Rickard Sjöberg et al, *Overview of HEVC High-Level Syntax and Reference Picture Management*, IEEE TRANSACTIONS ON CIRCUITS AND SYSTEMS FOR VIDEO TECHNOLOGY, Vol. 22, No. 12 at 1859 (December 2012) (emphasis added).

221. On information and belief, the VCL NAL Units contain segments of data which are used to generate an image (e.g., HEVC image) on a display device. Each VCL NAL Unit



comprises a discrete number of bites which make up a segment. The following excerpt from the HEVC specification describes the NAL unit as being a segment with a “demarcation” setting forth where the segment ends and begins.

NumBytesInNalUnit specifies the size of the NAL unit in bytes. This value is required for decoding of the NAL unit. Some form of demarcation of NAL unit boundaries is necessary to enable inference of NumBytesInNalUnit. One such demarcation method is specified in Annex B for the byte stream format. Other methods of demarcation may be specified outside of this Specification.

*High Efficiency Video Coding, Series H: Audiovisual And Multimedia Systems: Infrastructure Of Audiovisual Services – Coding Of Moving Video Rec. ITU-T H.265 at § 7.4.2.1 (February 2018) (emphasis added).*

222. On information and belief, VCL NAL Units comprise discrete video data that ends. It is between the receipt of VCL NAL Units that the overlay data (Non-VCL NAL Unit) data is received by the Amazon Products.

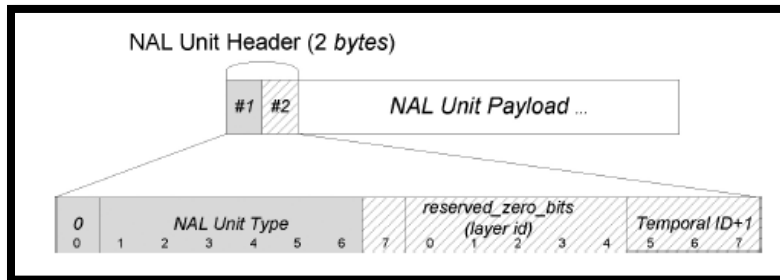

Thomas Schierl, Miska M. Hannuksela, Ye-Kui Wang, and Stephan Wenger, System Layer Integration of High Efficiency Video Coding, *IEEE TRANS. CIR. AND SYS. FOR VIDEO TECHNOLOGY*, VOL. 22, No. 12 at 1875 (December 2012).

223. On information and belief, the Amazon ‘918 Products are available to businesses and individuals throughout the United States.

224. On information and belief, the Amazon ‘918 Products are provided to businesses and individuals located in the Eastern District of Texas.

225. On information and belief, the HEVC bitstream structure is comprised of discreet data. In the gaps between the receipt by the Amazon ‘918 Products of VCL NAL Units Non-VCL NAL Units are received by the Amazon Products’ decoder.

An HEVC bitstream consists of a number of access units, each including coded data associated with a picture that has a distinct capturing or presentation time. Each access unit is divided into NAL units, including one or more VCL NAL units (i.e., coded slice NAL units) and zero or more non-VCL NAL units, e.g., parameter set NAL units or supplemental enhancement information (SEI) NAL units. Each NAL unit includes an NAL unit header and an NAL unit payload. Information in the NAL unit header can be (conveniently) accessed by media gateways, also known as media aware network elements (MANEs), for intelligent, media aware operations on the stream, such as stream adaptation.

Thomas Schierl, Miska M. Hannuksela, Ye-Kui Wang, and Stephan Wenger, System Layer Integration of High Efficiency Video Coding, *IEEE TRANS. CIR. AND SYS. FOR VIDEO TECHNOLOGY*, VOL. 22, NO. 12 at 1873 (December 2012).

226. On information and belief, Non-VCL NAL unit types include data such as supplemental enhancement information that is used to create overlays for display on the device.

Non-VCL NAL unit types			
Parameter sets	32	VPS_NUT	Video parameter set
	33	SPS_NUT	Sequence parameter set
	34	PPS_NUT	Picture parameter set
Delimiters	35	AUD_NUT	Access unit delimiter
	36	EOS_NUT	End of sequence
	37	EOB_NUT	End of bitstream
Filler data	38	FD_NUT	Filler data
Supplemental enhancement information (SEI)	39	PREFIX_SEI_NUT	
	40	SUFFIX_SEI_NUT	
Reserved	41-47	RSV	
Unspecified	48-63	UNSPEC	

Gary J. Sullivan et al, HIGH EFFICIENCY VIDEO CODING (HEVC) at 29 (September 2014).

227. On information and belief, Non-VCL NAL Units include supplemental enhancement information (“SEI”) messages. The SEI data that is received contains overlay information that can be combined with the image data that has already been received.

	Descriptor
sei_message( ) {	
payloadType = 0	
while( next_bits( 8 ) == 0xFF ) {	
ff_byte /* equal to 0xFF */	f(8)
payloadType += 255	
}	
last_payload_type_byte	u(8)
payloadType += last_payload_type_byte	
payloadSize = 0	
while( next_bits( 8 ) == 0xFF ) {	
ff_byte /* equal to 0xFF */	f(8)
payloadSize += 255	
}	
last_payload_size_byte	u(8)
payloadSize += last_payload_size_byte	
sei_payload( payloadType, payloadSize )	
}	

*High Efficiency Video Coding, SERIES H: AUDIOVISUAL AND MULTIMEDIA SYSTEMS: INFRASTRUCTURE OF AUDIOVISUAL SERVICES – CODING OF MOVING VIDEO REC. ITU-T H.265 at § 7.3.5 (February 2018).*

228. On information and belief, the Amazon ‘918 Products combine the VCL NAL Unit and Non-VCL NAL Unit information to create images that contain overlay information.

The NAL units are decoded by the decoder to produce the decoded pictures that are output from the decoder. Both the encoder and decoder store pictures in a decoded picture buffer (DPB). This buffer is mainly used for storing pictures so that previously coded pictures can be used to generate prediction signals to use when coding other pictures. These stored pictures are called reference pictures. . . . There are two classes of NAL units in HEVC—video coding layer (VCL) NAL units and non-VCL NAL units. Each VCL NAL unit carries one slice segment of coded picture data while the non-VCL NAL units contain control information that typically relates to multiple coded pictures. One coded picture, together with the non-VCL NAL units that are associated with the coded picture, is called an HEVC access unit.

Gary J. Sullivan et al, HIGH EFFICIENCY VIDEO CODING (HEVC) at 14-15 (September 2014) (emphasis added).

229. By making, using, testing, offering for sale, and/or selling products and services, including but not limited to the Amazon ‘918 Products, Amazon has injured Dynamic Data and is liable for directly infringing one or more claims of the ‘918 patent, including at least claim 18, pursuant to 35 U.S.C. § 271(a).

230. On information and belief, Amazon also indirectly infringes the ‘918 patent by actively inducing infringement under 35 U.S.C. § 271(b).

231. On information and belief, Amazon has had knowledge of the ‘918 patent since at least service of the Original Complaint in this case or shortly thereafter, and on information and belief, Amazon knew of the ‘918 patent and knew of its infringement, including by way of this lawsuit.

232. On information and belief, Amazon intended to induce patent infringement by third-party customers and users of the Amazon ‘918 Products and had knowledge that the inducing acts would cause infringement or was willfully blind to the possibility that its inducing acts would cause infringement. Amazon specifically intended and was aware that the normal and customary use of the accused products would infringe the ‘918 patent. Amazon performed the acts that constitute induced infringement, and would induce actual infringement, with knowledge of the ‘918 patent and with the knowledge that the induced acts would constitute infringement. For example, Amazon provides the Amazon ‘918 Products that have the capability of operating in a manner that infringe one or more of the claims of the ‘918 patent, including at least claim 18, and Amazon further provides documentation and training materials that cause customers and end users of the Amazon ‘918 Products to utilize the products in a manner that directly infringe one or more claims of the ‘918 patent.<sup>27</sup> By providing instruction and training to customers and end-users on how to use the Amazon ‘918 Products in a manner that directly infringes one or more claims of the ‘918 patent, including at least claim 18, Amazon specifically intended to induce infringement

---

<sup>27</sup> See, e.g., *Amazon Elastic Transcoder*, DEVELOPER GUIDE API VERSION 2012-09-25 (Nov. 17, 2016); *Amazon Web Services*, GENERAL REFERENCE VERSION 1.0 (2018); Lee Atkinson, *Delivering Media & Entertainment using the AWS Cloud*, AWS TRANSFORMATION DAY GERMANY PRESENTATION (Oct. 25, 2017); *Fire TV Stick*, AMAZON USER GUIDE; *Watching Video in 4K Ultra HD on Fire TV*, AMAZON HELP WEBSITE, available at: <https://www.amazon.com/gp/help/customer/display.html?nodeId=201859000> (last visited Nov. 2018); *Amazon Fire TV*, AMAZON USER GUIDE; *Amazon Fire Tablet and Kindle E-Reader Quick Setup Guide*, AMAZON USER GUIDE (2014); *Fire & Kindle User’s Guides*, Amazon Help Website, available at: <https://www.amazon.com/gp/help/customer/display.html?nodeId=200317150> (last visited Nov. 2018).

of the '918 patent. On information and belief, Amazon engaged in such inducement to promote the sales of the Amazon '918 Products, e.g., through Amazon user manuals, product support, marketing materials, and training materials to actively induce the users of the accused products to infringe the '918 patent. Accordingly, Amazon has induced and continues to induce users of the accused products to use the accused products in their ordinary and customary way to infringe the '918 patent, knowing that such use constitutes infringement of the '918 patent.

233. The '918 patent is well-known within the industry as demonstrated by multiple citations to the '918 patent in published patents and patent applications assigned to technology companies and academic institutions. Amazon is utilizing the technology claimed in the '918 patent without paying a reasonable royalty. Amazon is infringing the '918 patent in a manner best described as willful, wanton, malicious, in bad faith, deliberate, consciously wrongful, flagrant, or characteristic of a pirate.

234. To the extent applicable, the requirements of 35 U.S.C. § 287(a) have been met with respect to the '918 patent.

235. As a result of Amazon's infringement of the '918 patent, Dynamic Data has suffered monetary damages, and seeks recovery in an amount adequate to compensate for Amazon's infringement, but in no event less than a reasonable royalty for the use made of the invention by Amazon together with interest and costs as fixed by the Court.

**COUNT IV**  
**INFRINGEMENT OF U.S. PATENT NO. 8,184,689**

236. Dynamic Data references and incorporates by reference the preceding paragraphs of this Complaint as if fully set forth herein.

237. Amazon designs, makes, uses, sells, and/or offers for sale in the United States products and/or services for encoding and decoding video data.

238. Amazon designs, makes, sells, offers to sell, imports, and/or uses Amazon products that encode and/or decode video data, including: the Amazon Web Services platform (e.g., AWS Elastic Transcode) and Amazon’s streaming products/services (e.g., Amazon Video and Amazon Instant Video) (collectively, the “Amazon ‘689 Product(s)”).

239. On information and belief, one or more Amazon subsidiaries and/or affiliates use the Amazon ‘689 Products in regular business operations.

240. On information and belief, one or more of the Amazon ‘689 Products include technology for encoding and decoding video data.

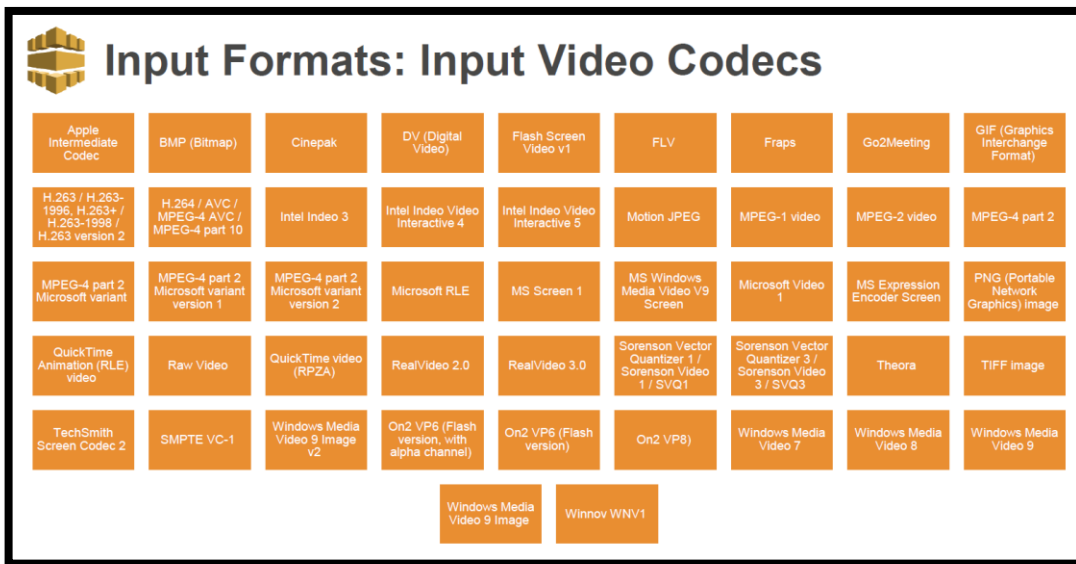

Jim Carrig and Tom Witman, *Amazon Elastic Transcoder*, AMAZON WEB SERVICES PRESENTATION at 6 (2015).

241. On information and belief, Amazon has directly infringed and continues to directly infringe the ‘689 patent by, among other things, making, using, offering for sale, and/or selling technology for encoding and decoding video data, including but not limited to the Amazon ‘689 Products.

242. On information and belief, one or more of the Amazon ‘689 Products reduce processing time and power consumption associated with encoding and decoding video stream data by reducing off-chip memory accesses through using simultaneous encoded/decoded images as a reference image for encoding/decoding at least one of the other simultaneously encoded/decoded images.

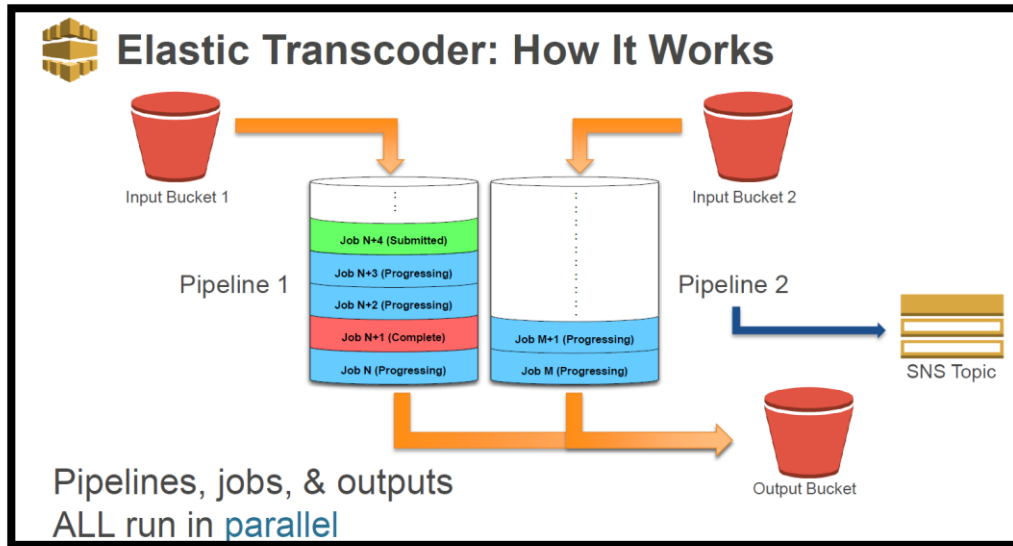

Jim Carrig and Tom Witman, *Amazon Elastic Transcoder*, AMAZON WEB SERVICES PRESENTATION at 12 (2015).

243. On information and belief, one or more of the Amazon ‘689 Products perform a method for encoding and decoding a video stream, including a plurality of images in a video processing apparatus having a processing unit coupled to a first memory, further comprising a second memory.

244. On information and belief, one or more of the Amazon ‘689 Products perform a method for encoding and decoding a video stream comprising providing a subset of image data stored in the second memory in the first memory.

245. On information and belief, one or more of the Amazon ‘689 Products perform a method for encoding and decoding a video stream comprising simultaneous encoding/decoding of

more than one image of the video stream, by accessing said subset, wherein the simultaneously encoding/decoding is performed by access sharing to at least one image.

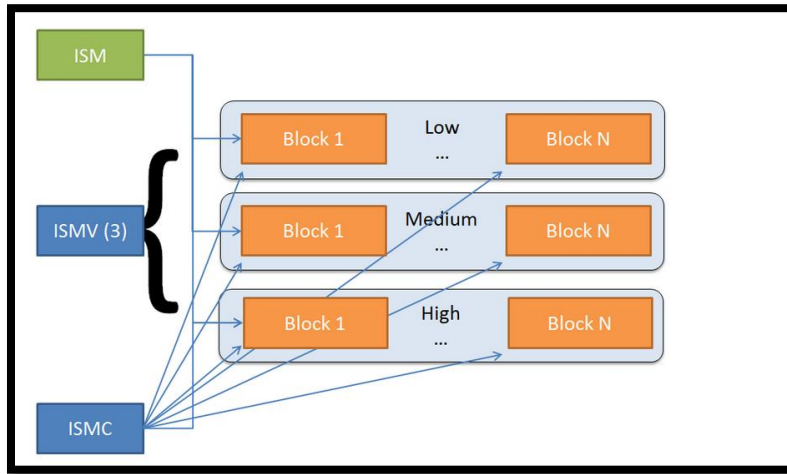

Jeff Barr, *Amazon Elastic Transcoder Now Support Smooth Streaming*, AWS NEWS BLOG (October 1, 2014), available at: <https://aws.amazon.com/blogs/aws/ets-smooth-streaming/>

246. On information and belief, the Amazon ‘689 Products are available to businesses and individuals throughout the United States.

247. On information and belief, the Amazon ‘689 Products are provided to businesses and individuals located in the Eastern District of Texas.

248. By making, using, testing, offering for sale, and/or selling products and services for encoding and decoding video data, including but not limited to the Amazon ‘689 Products, Amazon has injured Dynamic Data and is liable to the Plaintiff for directly infringing one or more claims of the ‘689 patent, including at least claim 1 pursuant to 35 U.S.C. § 271(a).

249. On information and belief, Amazon also indirectly infringes the ‘689 patent by actively inducing infringement under 35 U.S.C. § 271(b).

250. Amazon has had knowledge of the ‘689 patent since at least service of the Original Complaint in this case or shortly thereafter, and on information and belief, Amazon knew of the ‘689 patent and knew of its infringement, including by way of this lawsuit.



251. On information and belief, Amazon intended to induce patent infringement by third-party customers and users of the Amazon ‘689 Products and had knowledge that the inducing acts would cause infringement or was willfully blind to the possibility that its inducing acts would cause infringement. Amazon specifically intended and was aware that the normal and customary use of the accused products would infringe the ‘689 patent. Amazon performed the acts that constitute induced infringement, and would induce actual infringement, with knowledge of the ‘689 patent and with the knowledge that the induced acts would constitute infringement. For example, Amazon provides the Amazon ‘689 Products that have the capability of operating in a manner that infringe one or more of the claims of the ‘689 patent, including at least claim 1, and Amazon further provides documentation and training materials that cause customers and end users of the Amazon ‘689 Products to utilize the products in a manner that directly infringe one or more claims of the ‘689 patent.<sup>28</sup> By providing instruction and training to customers and end-users on how to use the Amazon ‘689 Products in a manner that directly infringes one or more claims of the ‘689 patent, including at least claim 1, Amazon specifically intended to induce infringement of the ‘689 patent. On information and belief, Amazon engaged in such inducement to promote the sales of the Amazon ‘689 Products, e.g., through Amazon user manuals, product support, marketing materials, and training materials to actively induce the users of the accused products to infringe the ‘689 patent. Accordingly, Amazon has induced and continues to induce users of the accused products to use the accused products in their ordinary and customary way to infringe the ‘689 patent, knowing that such use constitutes infringement of the ‘689 patent.

---

<sup>28</sup> See, e.g., *Amazon Elastic Transcoder*, DEVELOPER GUIDE API VERSION 2012-09-25 (Nov. 17, 2016); *Amazon Web Services*, GENERAL REFERENCE VERSION 1.0 (2018); Lee Atkinson, *Delivering Media & Entertainment using the AWS Cloud*, AWS TRANSFORMATION DAY GERMANY PRESENTATION (Oct. 25, 2017); *AWS Elemental Media Package*, AWS User Guide (2018); *Global Content Guide v6.0*, PRIME VIDEO GUIDE (Aug. 15, 2018); *Global Content Guide v5.2.2*, PRIME VIDEO GUIDE (March 13, 2018).

252. The '689 patent is well-known within the industry as demonstrated by multiple citations to the '689 patent in published patents and patent applications assigned to technology companies and academic institutions. Amazon is utilizing the technology claimed in the '689 patent without paying a reasonable royalty. Amazon is infringing the '689 patent in a manner best described as willful, wanton, malicious, in bad faith, deliberate, consciously wrongful, flagrant, or characteristic of a pirate.

253. To the extent applicable, the requirements of 35 U.S.C. § 287(a) have been met with respect to the '689 patent.

254. As a result of Amazon's infringement of the '689 patent, Dynamic Data has suffered monetary damages, and seeks recovery in an amount adequate to compensate for Amazon's infringement, but in no event less than a reasonable royalty for the use made of the invention by Amazon together with interest and costs as fixed by the Court.

**COUNT V**  
**INFRINGEMENT OF U.S. PATENT NO. 6,996,177**

255. Dynamic Data references and incorporates by reference the preceding paragraphs of this Complaint as if fully set forth herein.

256. Amazon designs, makes, uses, sells, and/or offers for sale in the United States products and/or services for motion estimation.

257. Amazon designs, makes, sells, offers to sell, imports, and/or uses Amazon products that comply with the H.265 standard. By way of example, the following Amazon Products perform encoding pursuant to the H.265 standard: the Amazon Web Services platform (e.g., AWS Elemental MediaConvert, AWS Elemental MediaLive, Amazon EC2 Accelerated Compute (EC2

G3 Instances), Amazon CloudFront); Amazon Fire TV products (e.g., Fire TV Stick 4k, Fire TV Cube, Fire TV (Gen 3)) (collectively, the “Amazon ‘177 Product(s)”).

258. On information and belief, one or more Amazon subsidiaries and/or affiliates use the Amazon ‘177 Products in regular business operations.

259. The accused Amazon Web Services platform products (e.g., AWS Elemental MediaConvert, AWS Elemental MediaLive, Amazon EC2 Accelerated Compute (EC2 G3 Instances), Amazon CloudFront) comply with the HEVC image processing standard. As shown in the following excerpts from Amazon documentation the accused Amazon Web Services Platform products comply with the HEVC standard.

Until recently, H.264 (also known as AVC) was the best codec for optimizing quality and reducing file sizes; many content publishers still use it today. But it’s quickly giving way to HEVC: High-Efficiency Video Coding. It’s also referred to as H.265; different standards groups employ different designations to refer to the same standard. HEVC requires more computing power than H.264, but it’s more efficient. Because AWS Elemental writes all of its encoding software from scratch, rather than relying on off-the-shelf encoding software, it is able to take the efficiency gains in each new generation of codec and adjust the software accordingly to get the best quality and/ or smallest video file sizes, along with the shortest encoding times.

Alicia Hunt, *A Video Compression Primer*, AWS MEDIA BLOG (January 30, 2019), available at: <https://aws.amazon.com/blogs/media/a-video-compression-primer/> (emphasis added).

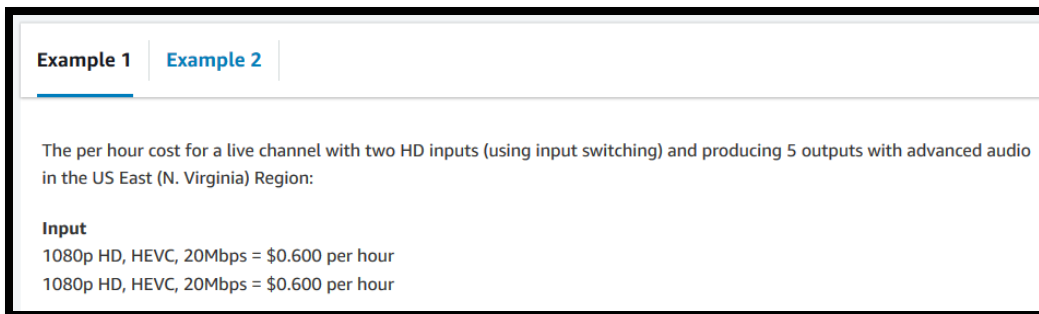

Example 1	Example 2
The per hour cost for a live channel with two HD inputs (using input switching) and producing 5 outputs with advanced audio in the US East (N. Virginia) Region:	
<b>Input</b>	
1080p HD, HEVC, 20Mbps = \$0.600 per hour	
1080p HD, HEVC, 20Mbps = \$0.600 per hour	

*AWS Elemental MediaLive Pricing*, AWS DOCUMENTATION, available at: <https://aws.amazon.com/medialive/pricing/>

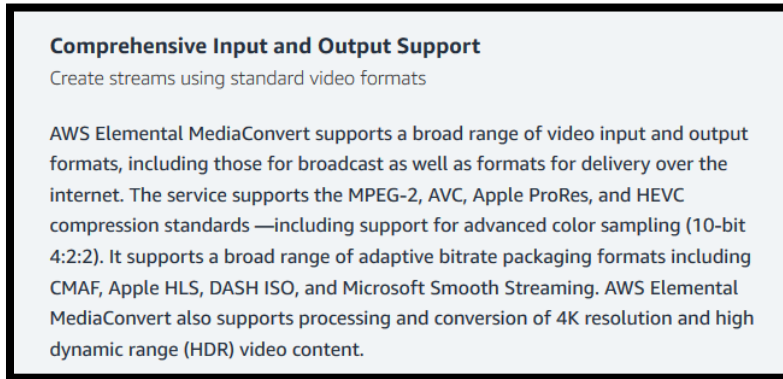

*AWS Elemental MediaConvert, AWS DOCUMENTATION, available at: <https://aws.amazon.com/mediaconvert/features/> (AWS Elemental MediaConvert supports a broad range of video input and output formats . . . [t]he service supports . . . HEVC compression standards.”).*

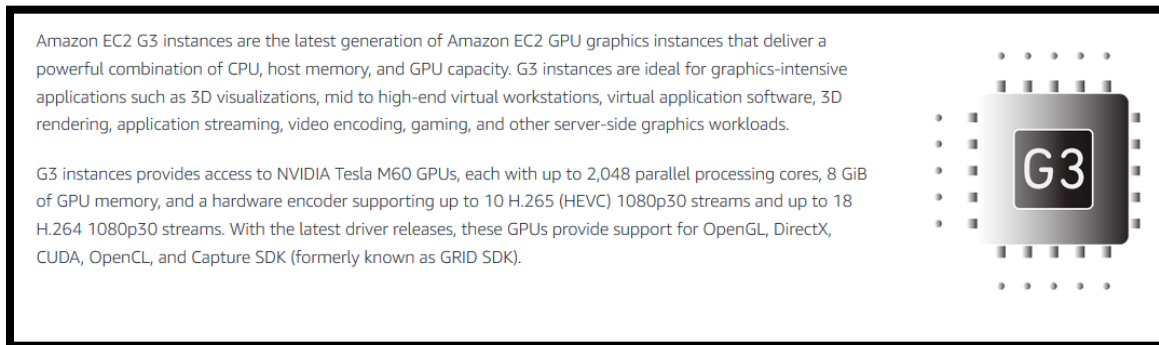

*Amazon EC2 G3 Instances, AWS DOCUMENTATION, available at: <https://aws.amazon.com/ec2/instance-types/g3/> (“G3 instances provides access to NVIDIA Tesla M60 GPUs, each with up to 2,048 parallel processing cores, 8 GiB of GPU memory, and a hardware encoder supporting up to 10 H.265 (HEVC) 1080p30 streams and up to 18 H.264 1080p30 streams.”).*

260. The accused Amazon Fire TV Products (e.g., Fire TV Stick 4k, Fire TV Cube, and Fire TV (Gen 3)) comply with the HEVC image processing standard. The below excerpt from Amazon Fire TV Developer documentation describes the accused Amazon Fire TV Products as complying with the requirements of the HEVC standard.

Fire TV Stick 4K			
Type	Codec	MIME type	Details
Video	H.265 (HEVC) (High Efficiency Video Coding)	video/hevc	Hardware accelerated up to 3840x2160p (4K) @ 60fps, 35 Mbps, Main 10 Profile Level 5.1, Color space 8-bit and 10-bit input with HDR10, HDR10+, HLG, and Dolby Vision support in rendering pipelines.

*Device Specifications for Fire TV*, AMAZON DEVELOPER DOCUMENTATION, available at: <https://developer.amazon.com/docs/fire-tv/device-specifications.html> (describing the HEVC encoding and decoding support for the Amazon Fire TV Products).

261. The following excerpt from a book that describes the HEVC motion estimation process describes that it is done through a Prediction Unit matching method and that the MV represents the displacement between the current Prediction Unit in the current frame and the matching Prediction Unit in the reference frame.

Motion estimation compares the current prediction unit (PU) with the spatially neighboring PUs in the reference frames, and chooses the one with the least difference to the current PU. The displacement between the current PU and the matching PU in the reference frames is signaled using a motion vector.

Sung-Fang Tsai, *et al.*, *Encoder Hardware Architecture for HEVC*, High Efficiency Video Coding (HEVC) (Vivienne Sze, Madhukar Budagavi, and Gary J. Sullivan (Editors)) at 347 (September 2014) (emphasis added).

262. On information and belief, by complying with the HEVC standard, the Amazon devices – such as the Amazon ‘177 Products – necessarily infringe the ‘177 patent. Mandatory sections of the HEVC standard require the elements required by certain claims of the ‘177 patent, including but not limited to claim 1. *High Efficiency Video Coding*, SERIES H: AUDIOVISUAL AND MULTIMEDIA SYSTEMS: INFRASTRUCTURE OF AUDIOVISUAL SERVICES – CODING OF MOVING VIDEO REC. ITU-T H.265 (February 2018). The following sections of the HEVC Standard are relevant to Amazon’s infringement of the ‘177 patent: “7.3.4 Scaling list data syntax;” 7.3.6.1 General slice segment header syntax;” “7.3.6.3 Weighted prediction parameters syntax;” “7.3.8.14 Delta QP

syntax;” “7.4.4 Profile, tier and level semantics;” and “7.4.7.3 Weighted prediction parameters semantics.”

263. Further, the Amazon ‘177 Products carry out a block-based motion vector estimation process that involves comparing a plurality of candidate vectors to determine block-based motion vectors. The Amazon ‘177 Products generate two predictor candidate motion vectors (a spatial motion vector and temporal motion vector). The first predictor candidate motion vector is drawn from a list of spatial motion vector candidates.

three spatially neighboring MVs. HEVC improves the MV prediction by applying an MV prediction competition as initially proposed in [18]. In HEVC, this competition was further adapted to large block sizes with so-called *advanced motion vector prediction* (AMVP) in [19]. In the *DIS Main profile*, AMVP has two predictor candidates competing for the prediction. Two spatial motion vector predictor (MVP) candidates are considered and, when at least one of them is not available or they are redundant, a temporal motion vector prediction (TMVP) candidate is considered. The candidates

Philipp Helle, Simon Oudin, Benjamin Bross, Detlev Marpe, M. Oguz Bici, Kemal Ugur, Joel Jung, Gordon Clare, and Thomas Wiegand, *Block Merging for Quadtree-Based Partitioning in HEVC*, IEEE TRANS. CIR. AND SYS. FOR VIDEO TECHNOLOGY, Vol. 22 No. 12 (December 2012) (“AMVP has two predictor candidates competing for the prediction. Two spatial motion vector predictor (MVP) candidates are considered and, when at least one of them is not available or they are redundant, a temporal motion vector prediction (TMVP) candidate is considered.”).

264. In AMVP, the motion vector selection process is composed by two steps wherein the candidate motion vectors are constructed into an index and then the motion vectors are compared. “In AMVP, the motion vector selection process is composed by two steps in encoder implementation. The first step is the motion vector candidate set construction process and the second step is the best motion vector selection step. In the first step, the motion vector candidate set is organized by selecting the motion vectors spatially and temporally.” Gwo-Long Li, Chuen-

Ching Wang, and Kuang-Hung Chiang, *An Efficient Motion Vector Prediction Method for Avoiding AMVP Data Dependency For HEVC*, 2014 IEEE INTERNATIONAL CONFERENCE ON ACOUSTIC, SPEECH AND SIGNAL PROCESSING (ICASSP) at 7412-13 (2014).

265. On information and belief, one or more Amazon subsidiaries and/or affiliates use the Amazon ‘177 Products in regular business operations.

266. On information and belief, the Amazon ‘177 Products are available to businesses and individuals throughout the United States.

267. On information and belief, the Amazon ‘177 Products are provided to businesses and individuals located in the Eastern District of Texas.

268. The HEVC Standard provides details regarding what would be required for a compliant HEVC encoder—*e.g.*, the standard uses terms such as “encoding,” “coding,” “compressing,” and other similar terms to describe the encoding process.

269. On information and belief, Amazon has directly infringed and continues to directly infringe the ‘177 patent by, among other things, making, using, offering for sale, and/or selling products and services for motion estimation and motion-compensated picture signal processing.

270. Amazon ‘177 Products use a block-based motion vector estimation process that compares a plurality of candidate vectors to determine block-based motion vectors. The Amazon ‘177 Products contain a video encoder that selects an image segment of a second video image corresponding to an image segment of a first video image.

271. The Amazon ‘177 Products determine at least a most frequently occurring block-based motion vector. Further, the Amazon ‘177 Products contain functionality wherein the motion vector prediction performed includes the ability to transmit in the bitstream the candidate index of

motion vectors. Documentation of the encoding process states that the encoder will “pick up the MV [motion vector] to use as an estimator using the index sent by the encoder in the bitstream.”

#### **Inter prediction**

For motion vector prediction HEVC has two reference lists: L0 and L1. They can hold 16 references each, but the maximum total number of unique pictures is 8. Multiple instances of the same ref frame can be stored with different weights. HEVC motion estimation is much more complex than in AVC. It uses list indexing. There are two main prediction modes: Merge and Advanced MV. Each PU can use one of those methods and can have forward (a MV) or bi-directional prediction (2 MV). In Advanced MV mode a list of candidates MV is created (spatial and temporal candidates picked with a complex, probabilistic logic), when the list is created only the best candidate index is transmitted in the bitstream plus the MV delta (the difference between the real MV and the prediction). On the other side, the decoder will build and update continuously the same candidate list using the exact same rules used by the encoder and will pick-up the MV to use as estimator using the index sent by the encoder in the bitstream. The merge mode is similar, the main difference is that the candidates' list is calculated from neighboring MV and is not added to a delta MV. It is the equivalent of “skip” mode in AVC.

Fabio Sonnati, *H265 – Part I: Technical Overview*, VIDEO ENCODING & STREAMING TECHNOLOGIES WEBSITE (June 20, 2014) (emphasis added).

272. On information and belief, any implementation of the HEVC standard would infringe the ‘177 patent as every possible implementation of the standard requires: compliant devices to carry out a global motion vector estimation process using the most frequently occurring block-based motion vectors. This process of vector candidate selection allows the Amazon ‘177 Products to obtain a global motion vector. Specifically, the HEVC standard generates a set of candidate motion vectors for the group of pixels, with the candidate motion vectors being extracted from a set of previously estimated motion vectors. After the candidate motion vectors are generated, if there are two spatial motion vectors that are identical, that is determined to be the most frequently occurring block-based motion vector and the frequently occurring spatial motion vector and temporal motion vector candidate are used to generate the global motion vector. “In HEVC, this competition was further adapted to large block sizes with so-called advanced motion vector prediction (AMVP). In the DIS Main profile, AMVP has two predictor candidates



competing for the prediction. Two spatial motion vector predictor (MVP) candidates are considered and, when at least one of them is not available or they are redundant, a temporal motion vector prediction (TMVP) candidate is considered.” Kemal Ugur, Joel Jung, Gordon Clare, and Thomas Wiegand, *Block Merging for Quadtree-Based Partitioning in HEVC*, *IEEE TRANS. CIR. AND SYS. FOR VIDEO TECHNOLOGY*, Vol. 22 No. 12 (December 2012).

273. The Amazon ‘177 Products apply the global motion vector as a candidate vector to the block-based motion vector estimation process. Specially, the Amazon ‘177 Products calculate the global motion vector by calculating a difference between the second motion vector and the first motion vector. The further candidate motion vector is calculated at the end of the process diagram below (as shown in the below figure) and applied to the block-based motion vector estimation process.

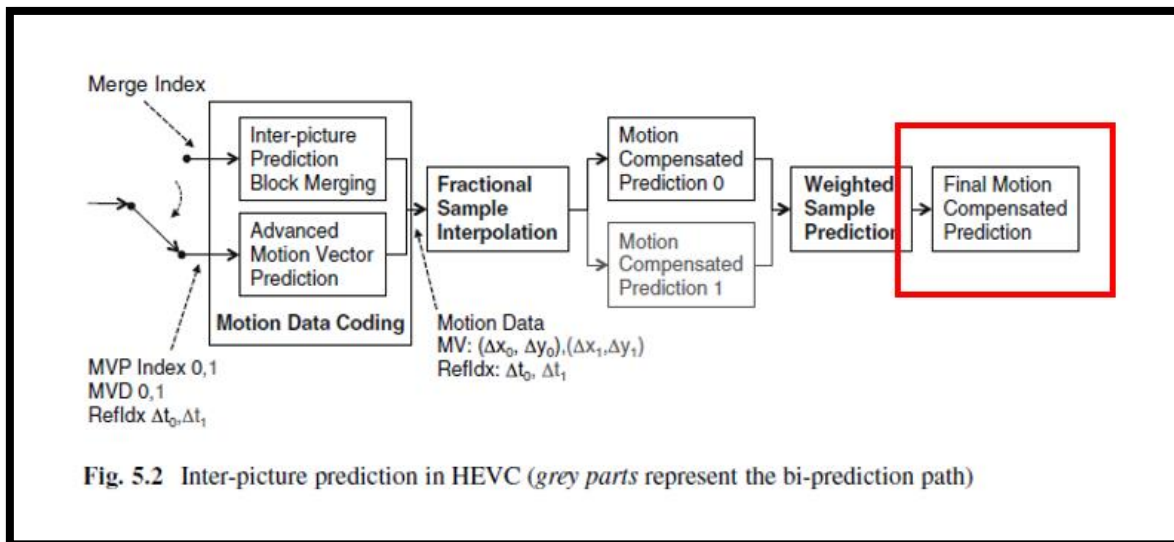

Gary J. Sullivan, *et al.*, HEVC, HIGH EFFICIENCY VIDEO CODING (HEVC) at 115 (September 2014) (emphasis added).

274. Further, the Amazon ‘177 Products enable AMVP wherein several of the most probable candidate vectors based on data from adjacent prediction blocks are used to create a

global estimation vector and that vector is applied to the block-based motion estimation functionality.

Motion vector signaling: Advanced motion vector prediction (AMVP) is used, including derivation of several most probable candidates based on data from adjacent PBs and the reference picture. A “merge” mode for MV coding can be also used, allowing the inheritance of MVs from neighboring PBs. Moreover, compared to H.264/MPEG-4 AVC, improved “skipped” and “direct” motion inference are also specified.

Gary J. Sullivan, *et al.*, *Overview of the High Efficiency Video Coding (HEVC) Standard*, PRE-PUBLICATION DRAFT, TO APPEAR IN IEEE TRANS. ON CIRCUITS AND SYSTEMS FOR VIDEO TECHNOLOGY at 3 (December 2012) (emphasis added).

275. On information and belief, Amazon has directly infringed and continues to directly infringe the ‘177 patent by, among other things, making, using, offering for sale, and/or selling products and services for motion estimation and motion-compensated picture signal processing.

276. By making, using, testing, offering for sale, and/or selling products and services, including but not limited to the Amazon ‘177 Products, Amazon has injured Dynamic Data and is liable for directly infringing one or more claims of the ‘177 patent, including at least claim 1, pursuant to 35 U.S.C. § 271(a).

277. On information and belief, Amazon also indirectly infringes the ‘177 patent by actively inducing infringement under 35 U.S.C. § 271(b).

278. On information and belief, Amazon has had knowledge of the ‘177 patent since at least service of the Original Complaint in this case or shortly thereafter, and on information and belief, Amazon knew of the ‘177 patent and knew of its infringement, including by way of this lawsuit.

279. On information and belief, Amazon intended to induce patent infringement by third-party customers and users of the Amazon ‘177 Products and had knowledge that the inducing acts would cause infringement or was willfully blind to the possibility that its inducing acts would

cause infringement. Amazon specifically intended and was aware that the normal and customary use of the accused products would infringe the ‘177 patent. Amazon performed the acts that constitute induced infringement, and would induce actual infringement, with knowledge of the ‘177 patent and with the knowledge that the induced acts would constitute infringement. For example, Amazon provides the Amazon ‘177 Products that have the capability of operating in a manner that infringe one or more of the claims of the ‘177 patent, including at least claim 1, and Amazon further provides documentation and training materials that cause customers and end users of the Amazon ‘177 Products to utilize the products in a manner that directly infringe one or more claims of the ‘177 patent.<sup>29</sup> By providing instruction and training to customers and end-users on how to use the Amazon ‘177 Products in a manner that directly infringes one or more claims of the ‘177 patent, including at least claim 1, Amazon specifically intended to induce infringement of the ‘177 patent. On information and belief, Amazon engaged in such inducement to promote the sales of the Amazon ‘177 Products, e.g., through Amazon user manuals, product support, marketing materials, and training materials to actively induce the users of the accused products to infringe the ‘177 patent. Accordingly, Amazon has induced and continues to induce users of the accused products to use the accused products in their ordinary and customary way to infringe the ‘177 patent, knowing that such use constitutes infringement of the ‘177 patent.

280. The ‘177 patent is well-known within the industry as demonstrated by multiple citations to the ‘177 patent in published patents and patent applications assigned to technology

---

<sup>29</sup> See, e.g., *Amazon Elastic Transcoder*, DEVELOPER GUIDE API VERSION 2012-09-25 (Nov. 17, 2016); *Amazon Web Services*, GENERAL REFERENCE VERSION 1.0 (2018); Lee Atkinson, *Delivering Media & Entertainment using the AWS Cloud*, AWS TRANSFORMATION DAY GERMANY PRESENTATION (Oct. 25, 2017); *Fire TV Stick*, AMAZON USER GUIDE; *Watching Video in 4K Ultra HD on Fire TV*, AMAZON HELP WEBSITE, available at: <https://www.amazon.com/gp/help/customer/display.html?nodeId=201859000> (last visited Nov. 2018); *Amazon Fire TV*, AMAZON USER GUIDE.

companies and academic institutions. Amazon is utilizing the technology claimed in the ‘177 patent without paying a reasonable royalty. Amazon is infringing the ‘177 patent in a manner best described as willful, wanton, malicious, in bad faith, deliberate, consciously wrongful, flagrant, or characteristic of a pirate.

281. To the extent applicable, the requirements of 35 U.S.C. § 287(a) have been met with respect to the ‘177 patent.

282. As a result of Amazon’s infringement of the ‘177 patent, Dynamic Data has suffered monetary damages, and seeks recovery in an amount adequate to compensate for Amazon’s infringement, but in no event less than a reasonable royalty for the use made of the invention by Amazon together with interest and costs as fixed by the Court.

**COUNT VI**  
**INFRINGEMENT OF U.S. PATENT NO. 8,311,112**

283. Dynamic Data references and incorporates by reference the preceding paragraphs of this Complaint as if fully set forth herein.

284. Amazon designs, makes, uses, sells, and/or offers for sale in the United States products and/or services for video compression.

285. Amazon designs, makes, sells, offers to sell, imports, and/or uses Amazon products that comply with the H.265 standard. By way of example, the following Amazon Products perform encoding pursuant to the H.265 standard: the Amazon Web Services platform (e.g., AWS Elemental MediaConvert, AWS Elemental MediaLive, Amazon EC2 Accelerated Compute (EC2 G3 Instances), Amazon CloudFront); Amazon Fire TV products (e.g., Fire TV Stick 4k, Fire TV Cube, Fire TV (Gen 3)) (collectively, the “Amazon ‘112 Product(s)”).

286. On information and belief, one or more Amazon subsidiaries and/or affiliates use the Amazon ‘112 Products in regular business operations.

287. The accused Amazon Web Services platform products (e.g., AWS Elemental MediaConvert, AWS Elemental MediaLive, Amazon EC2 Accelerated Compute (EC2 G3 Instances), Amazon CloudFront) comply with the HEVC image processing standard. As shown in the following excerpts from Amazon documentation the accused Amazon Web Services Platform products comply with the HEVC standard.

Until recently, H.264 (also known as AVC) was the best codec for optimizing quality and reducing file sizes; many content publishers still use it today. But it’s quickly giving way to HEVC: High-Efficiency Video Coding. It’s also referred to as H.265; different standards groups employ different designations to refer to the same standard. HEVC requires more computing power than H.264, but it’s more efficient. Because AWS Elemental writes all of its encoding software from scratch, rather than relying on off-the-shelf encoding software, it is able to take the efficiency gains in each new generation of codec and adjust the software accordingly to get the best quality and/ or smallest video file sizes, along with the shortest encoding times.

Alicia Hunt, *A Video Compression Primer*, AWS MEDIA BLOG (January 30, 2019), available at: <https://aws.amazon.com/blogs/media/a-video-compression-primer/> (emphasis added).

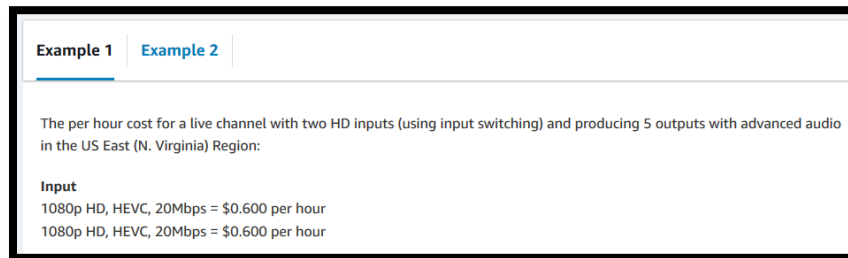

The screenshot shows a pricing table for AWS Elemental MediaLive. It has two tabs: 'Example 1' (selected) and 'Example 2'. The text below the tabs reads: 'The per hour cost for a live channel with two HD inputs (using input switching) and producing 5 outputs with advanced audio in the US East (N. Virginia) Region:'. Below this, there is a section titled 'Input' with two rows of data: '1080p HD, HEVC, 20Mbps = \$0.600 per hour' and '1080p HD, HEVC, 20Mbps = \$0.600 per hour'.

Example 1	Example 2
The per hour cost for a live channel with two HD inputs (using input switching) and producing 5 outputs with advanced audio in the US East (N. Virginia) Region:	
<b>Input</b>	
1080p HD, HEVC, 20Mbps = \$0.600 per hour	
1080p HD, HEVC, 20Mbps = \$0.600 per hour	

*AWS Elemental MediaLive Pricing*, AWS DOCUMENTATION, available at: <https://aws.amazon.com/medialive/pricing/>

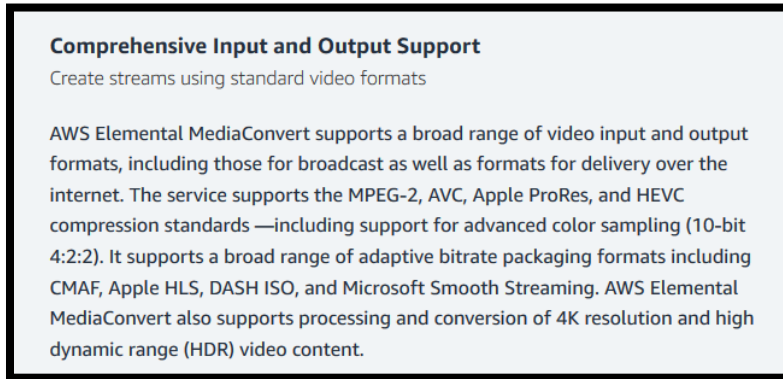

*AWS Elemental MediaConvert, AWS DOCUMENTATION, available at: <https://aws.amazon.com/mediaconvert/features/> (AWS Elemental MediaConvert supports a broad range of video input and output formats . . . [t]he service supports . . . HEVC compression standards.”).*

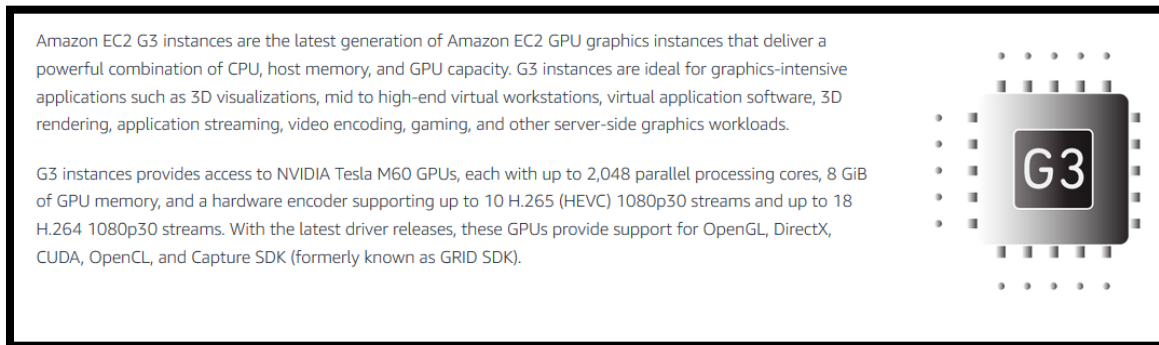

*Amazon EC2 G3 Instances, AWS DOCUMENTATION, available at: <https://aws.amazon.com/ec2/instance-types/g3/> (“G3 instances provides access to NVIDIA Tesla M60 GPUs, each with up to 2,048 parallel processing cores, 8 GiB of GPU memory, and a hardware encoder supporting up to 10 H.265 (HEVC) 1080p30 streams and up to 18 H.264 1080p30 streams.”).*

288. The accused Amazon Fire TV Products (e.g., Fire TV Stick 4k, Fire TV Cube, and Fire TV (Gen 3)) comply with the HEVC image processing standard. The below excerpt from Amazon Fire TV Developer documentation describes the accused Amazon Fire TV Products as complying with the requirements of the HEVC standard.

Fire TV Stick 4K			
Type	Codec	MIME type	Details
Video	H.265 (HEVC) (High Efficiency Video Coding)	video/hevc	Hardware accelerated up to 3840x2160p (4K) @ 60fps, 35 Mbps, Main 10 Profile Level 5.1, Color space 8-bit and 10-bit input with HDR10, HDR10+, HLG, and Dolby Vision support in rendering pipelines.

*Device Specifications for Fire TV*, AMAZON DEVELOPER DOCUMENTATION, available at: <https://developer.amazon.com/docs/fire-tv/device-specifications.html> (describing the HEVC encoding and decoding support for the Amazon Fire TV Products).

289. On information and belief, the Amazon devices by complying with the HEVC standard – such as the Amazon ‘112 Products – necessarily infringe the ‘112 patent. Mandatory sections of the HEVC standard require the elements required by certain claims of the ‘122 patent, including but not limited to claim 11. *High Efficiency Video Coding*, SERIES H: AUDIOVISUAL AND Multimedia SYSTEMS: INFRASTRUCTURE OF AUDIOVISUAL SERVICES – CODING OF MOVING VIDEO REC. ITU-T H.265 (February 2018). The following sections of the HEVC Standard are relevant to Amazon’s infringement of the ‘112 patent: “3.110 Prediction Unit Definition;” “6.3.2 Block and quadtree structures;” “6.3.3 Spatial or component-wise partitioning;” “6.4.2 Derivation process for prediction block availability;” “7.3.8.5 Coding unit syntax;” “7.3.8.6 Prediction unit syntax;” “7.4.3.3.1 General picture parameter set RBSP semantics;” and “7.4.7.3 Weighted prediction parameters semantics.”

290. The Amazon ‘112 Products perform encoding using motion compensation, specifically, inter-picture prediction wherein the Amazon ‘112 Product makes use of the temporal correlation between pictures in order to derive a motion-compensated prediction for a block of image samples. Each image is divided into blocks (prediction units) and the Amazon ‘112 Products compare the prediction unit in a first image with the spatially neighboring prediction units in a second image (reference image). The displacement between the current prediction unit

and the matching prediction unit in the second image (reference image) is signaled using a motion vector. Further, the Amazon '112 Products contain functionality wherein during the motion estimation process the block size used for prediction units can range from  $4 \times 8/8 \times 4$  to  $64 \times 64$ .

A block-wise prediction residual *is computed from corresponding regions of previously decoded pictures (inter-picture motion compensated prediction) or neighboring previously decoded samples from the same picture (intra-picture spatial prediction)*. The residual is then processed by a block transform, and the transform coefficients are quantized and entropy coded. Side information data such as motion vectors and mode switching parameters are also encoded and transmitted.

*Standardized Extensions of High Efficiency Video Coding (HEVC), IEEE JOURNAL OF SELECTED TOPICS IN SIGNAL PROCESSING, Vol. 7, No. 6 at 1002 (December 2013) (emphasis added).*

291. The Amazon '112 Products also use intra-picture estimation between blocks (prediction units) within an image retrieved from memory. The frames are then processed using both motion compensation and motion estimation. The motion compensation functionality used by the Amazon '112 Products include quarter-sample precision for the motion vectors and 7-tap or 8-tap filters that are used for interpolation of fractional-sample positions.

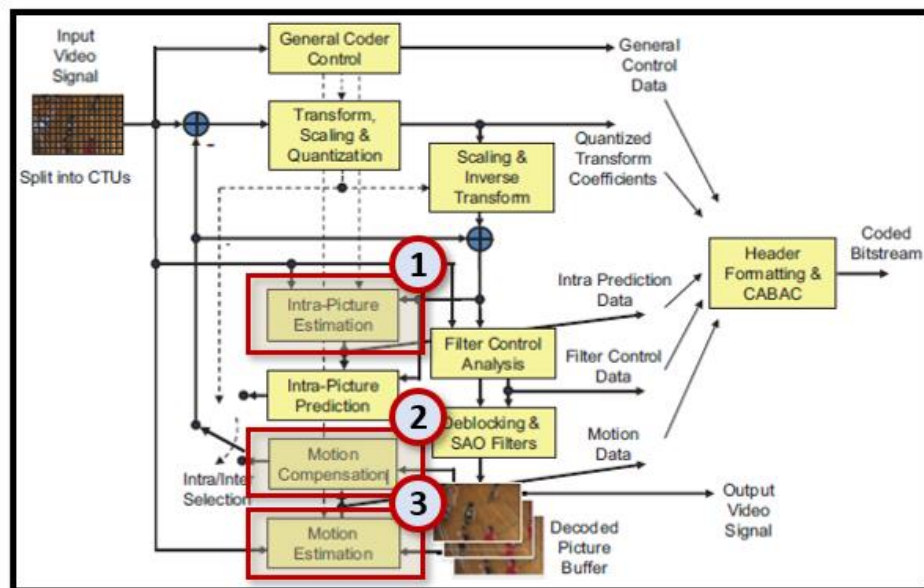

*Standardized Extensions of High Efficiency Video Coding (HEVC), IEEE JOURNAL OF SELECTED TOPICS IN SIGNAL PROCESSING, VOL. 7, NO. 6 at 1002 (December 2013) (emphasis added) (the annotations showing (1) intra-picture prediction, (2) motion compensation, and (3) motion estimation).*



292. The Amazon ‘112 Products contain functionality for motion compensation where two or more motion vectors can be applied. Further, one or two motion vectors can be applied to the image processing process. The application of the motion vectors leads to uni-predictive or bi-predictive coding, respectively, where bi-predictive coding uses an averaged result of two predictions to form the final prediction.

**Summary**

Recommendation ITU-T H.265 | International Standard ISO/IEC 23008-2 represents an evolution of the existing video coding Recommendations (ITU-T H.261, ITU-T H.262, ITU-T H.263 and ITU-T H.264) and was developed in response to the growing need for higher compression of moving pictures for various applications such as Internet streaming, communication, videoconferencing, digital storage media and television broadcasting. It is also designed to enable the use of the coded video representation in a flexible manner for a wide variety of network environments. The use of this Recommendation | International Standard allows motion video to be manipulated as a form of computer data and to be stored on various storage media, transmitted and received over existing and future networks and distributed on existing and future broadcasting channels.

Series H: Audiovisual and Multimedia Systems- Infrastructure of Audiovisual Services – Coding of Moving Video, INTERNATIONAL TELECOMMUNICATIONS UNIONS - TU-T H.265, V.5 at I (February 2018).

293. On information and belief, one or more Amazon subsidiaries and/or affiliates use the Amazon ‘112 Products in regular business operations.

294. On information and belief, one or more of the Amazon ‘112 Products include technology for video compression.

295. On information and belief, Amazon has directly infringed and continues to directly infringe the ‘112 patent by, among other things, making, using, offering for sale, and/or selling technology for video compression, including but not limited to the Amazon ‘112 Products.

296. The Amazon ‘112 Products comprise systems wherein a frame coding unit is configured to perform predictive coding on a set of pixels of a macroblock of pixels. Further, the predictive coding functionality uses a first group of reference pixels and a macroblock of pixels from the video frame. Specifically, the Amazon ‘112 Products, when selecting a temporal

candidate for HEVC intra-frame encoding, default to the right bottom position just outside of the collocated prediction unit.

It can be seen from Fig. 5.4b that only motion vectors from spatial neighboring blocks to the left and above the current block are considered as spatial MVP candidates. This can be explained by the fact that the blocks to the right and below the current block are not yet decoded and hence, their motion data is not available. Since the co-located picture is a reference picture which is already decoded, it is possible to also consider motion data from the block at the same position, from blocks to the right of the co-located block or from the blocks below. In HEVC, the block to the bottom right and at the center of the current block have been determined to be the most suitable to provide a good temporal motion vector predictor (TMVP).

Benjamin Bross, *et al.*, *Inter-picture prediction in HEVC*, in HIGH EFFICIENCY VIDEO CODING (HEVC) at 119 (2014) (emphasis added).

297. On information and belief, one or more of the Amazon ‘112 Products perform predictive coding on a macroblock of a video frame such that a set of pixels of the macroblock is coded using some of the pixels from the same video frame as reference pixels and the rest of the macroblock is coded using reference pixels from at least one other video frame.

298. On information and belief, the Amazon ‘112 Products comprise an inter-frame coding unit that is configured to perform predictive coding on the rest of the macroblock of pixels using a second group of reference pixels. The second group of reference pixels that are used to perform inter-frame coding are drawn from at least one other video frame. The image data processed by the Amazon ‘112 Products is encoded using inter-picture prediction that makes use of the temporal correlation between pictures to derive a motion-compensated prediction (MCP) for a block of image samples. For this block-based motion-compensated prediction, an image is divided into rectangular blocks. Assuming homogeneous motion inside one block, and that moving objects are larger than one block, for each block, a corresponding block in a previously decoded picture can be found that serves as a predictor (a second image). Both the first and second images are retrieved by the Amazon ‘112 Products from storage such as on chip memory. The

general concept of inter-frame-based encoding using motion-compensated prediction based on a translational motion model is illustrated below.

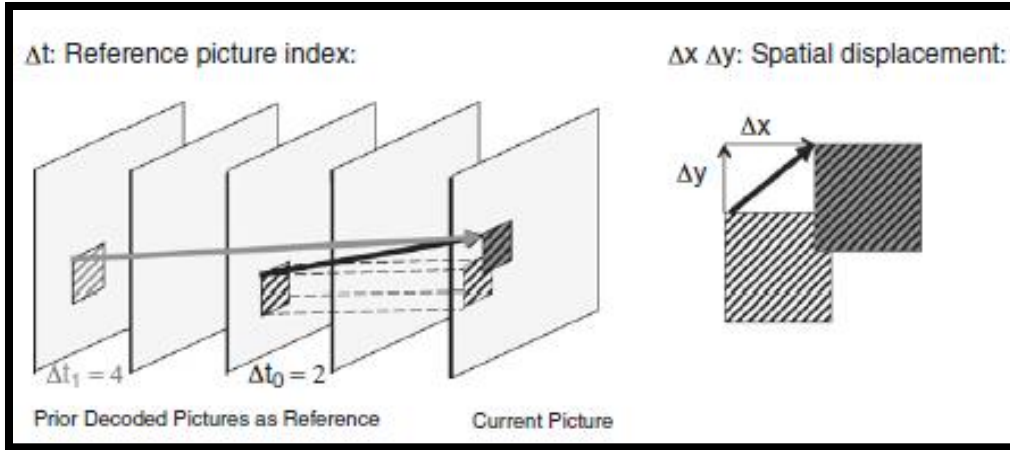

Benjamin Bross, *Inter-Picture Prediction In HEVC*, HIGH EFFICIENCY VIDEO CODING (HEVC) at 114 (September 2014).

299. On information and belief, one or more of the Amazon ‘112 Products include a system for video compression comprising an intra-frame coding unit configured to perform predictive coding on a set of pixels of a macroblock of pixels using a first group of reference pixels, the macroblock of pixels and the first group of reference pixels being from a video frame.

300. On information and belief, Amazon has directly infringed and continues to directly infringe the ‘112 patent by, among other things, making, using, offering for sale, and/or selling technology for video compression, including but not limited to the Amazon ‘112 Products.

301. On information and belief, the Amazon ‘112 Products are available to businesses and individuals throughout the United States.

302. On information and belief, the Amazon ‘112 Products are provided to businesses and individuals located in the Eastern District of Texas.

303. By making, using, testing, offering for sale, and/or selling products and services for interpolating a pixel during the interlacing of a video signal, including but not limited to the

Amazon '112 Products, Amazon has injured Dynamic Data and is liable to the Plaintiff for directly infringing one or more claims of the '112 patent, including at least claim 11 pursuant to 35 U.S.C. § 271(a).

304. On information and belief, Amazon also indirectly infringes the '112 patent by actively inducing infringement under 35 U.S.C. § 271(b).

305. Amazon has had knowledge of the '112 patent since at least service of the Original Complaint in this case or shortly thereafter, and on information and belief, Amazon knew of the '112 patent and knew of its infringement, including by way of this lawsuit.

306. On information and belief, Amazon intended to induce patent infringement by third-party customers and users of the Amazon '112 Products and had knowledge that the inducing acts would cause infringement or was willfully blind to the possibility that its inducing acts would cause infringement. Amazon specifically intended and was aware that the normal and customary use of the accused products would infringe the '112 patent. Amazon performed the acts that constitute induced infringement, and would induce actual infringement, with knowledge of the '112 patent and with the knowledge that the induced acts would constitute infringement. For example, Amazon provides the Amazon '112 Products that have the capability of operating in a manner that infringe one or more of the claims of the '112 patent, including at least claim 11, and Amazon further provides documentation and training materials that cause customers and end users of the Amazon '112 Products to utilize the products in a manner that directly infringe one or more claims of the '112 patent.<sup>30</sup> By providing instruction and training to customers and end-users on

---

<sup>30</sup> See, e.g., *Amazon Elastic Transcoder*, DEVELOPER GUIDE API VERSION 2012-09-25 (Nov. 17, 2016); *Amazon Web Services*, GENERAL REFERENCE VERSION 1.0 (2018); Lee Atkinson, *Delivering Media & Entertainment using the AWS Cloud*, AWS TRANSFORMATION DAY GERMANY PRESENTATION (Oct. 25, 2017); *Fire TV Stick*, AMAZON USER GUIDE; *Watching Video in 4K Ultra HD on Fire TV*, AMAZON HELP WEBSITE, available at:

how to use the Amazon ‘112 Products in a manner that directly infringes one or more claims of the ‘112 patent, including at least claim 11, Amazon specifically intended to induce infringement of the ‘112 patent. On information and belief, Amazon engaged in such inducement to promote the sales of the Amazon ‘112 Products, e.g., through Amazon user manuals, product support, marketing materials, and training materials to actively induce the users of the accused products to infringe the ‘112 patent. Accordingly, Amazon has induced and continues to induce users of the accused products to use the accused products in their ordinary and customary way to infringe the ‘112 patent, knowing that such use constitutes infringement of the ‘112 patent.

307. The ‘112 patent is well-known within the industry as demonstrated by multiple citations to the ‘112 patent in published patents and patent applications assigned to technology companies and academic institutions. Amazon is utilizing the technology claimed in the ‘112 patent without paying a reasonable royalty. Amazon is infringing the ‘112 patent in a manner best described as willful, wanton, malicious, in bad faith, deliberate, consciously wrongful, flagrant, or characteristic of a pirate.

308. To the extent applicable, the requirements of 35 U.S.C. § 287(a) have been met with respect to the ‘112 patent.

309. As a result of Amazon’s infringement of the ‘112 patent, Dynamic Data has suffered monetary damages, and seeks recovery in an amount adequate to compensate for Amazon’s infringement, but in no event less than a reasonable royalty for the use made of the invention by Amazon together with interest and costs as fixed by the Court.

---

<https://www.amazon.com/gp/help/customer/display.html?nodeId=201859000> (last visited Nov. 2018); *Amazon Fire TV*, AMAZON USER GUIDE.

**COUNT VII**  
**INFRINGEMENT OF U.S. PATENT NO. 7,894,529**

310. Dynamic Data references and incorporates by reference the preceding paragraphs of this Complaint as if fully set forth herein.

311. Amazon designs, makes, uses, sells, and/or offers for sale in the United States products and/or services for determining motion vectors that are each assigned to individual image regions.

312. Amazon designs, makes, sells, offers to sell, imports, and/or uses Amazon products capable of decoding video data in compliance with the H.265 standard. By way of example, the following Amazon Products perform decoding pursuant to the H.265 standard: the Amazon Web Services platform (e.g., AWS Elemental MediaConvert, AWS Elemental MediaLive, Amazon EC2 Accelerated Compute (EC2 G3 Instances), Amazon CloudFront); Amazon Fire TV products (e.g., Fire TV Stick 4k, Fire TV Cube, Fire TV (Gen 3)) (collectively, the “Amazon ‘529 Product(s)”).

313. On information and belief, one or more Amazon subsidiaries and/or affiliates use the Amazon ‘529 Products in regular business operations.

314. The accused Amazon Web Services platform products (e.g., AWS Elastic Transcoder, AWS Elemental MediaConvert, AWS Elemental MediaLive, Amazon EC2 Accelerated Compute (EC2 G3 Instances), and Amazon CloudFront) comply with the HEVC image processing standard. As shown in the following excerpts from Amazon Documentation the accused Amazon Web Services Platform functionalities comply with the HEVC standard.

Until recently, H.264 (also known as AVC) was the best codec for optimizing quality and reducing file sizes; many content publishers still use it today. But it’s quickly giving way to HEVC: High-Efficiency Video Coding. It’s also referred to as H.265; different standards groups employ different designations to refer to the same standard. HEVC requires more computing power than H.264, but

it's more efficient. Because AWS Elemental writes all of its encoding software from scratch, rather than relying on off-the-shelf encoding software, it is able to take the efficiency gains in each new generation of codec and adjust the software accordingly to get the best quality and/ or smallest video file sizes, along with the shortest encoding times.

Alicia Hunt, *A Video Compression Primer*, AWS MEDIA BLOG (January 30, 2019), available at: <https://aws.amazon.com/blogs/media/a-video-compression-primer/> (emphasis added).

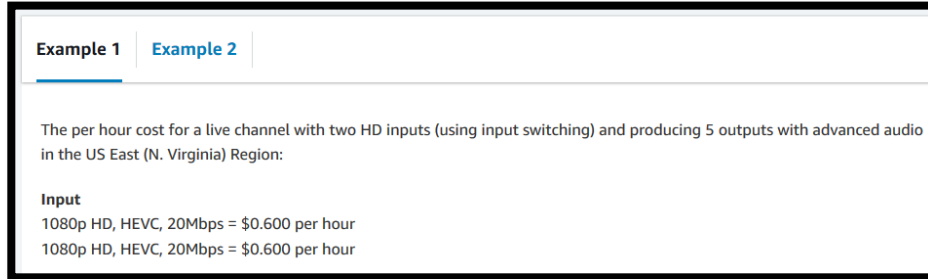

The screenshot shows a pricing table for AWS Elemental MediaLive. It has two tabs: 'Example 1' and 'Example 2'. Under 'Example 1', it states: 'The per hour cost for a live channel with two HD inputs (using input switching) and producing 5 outputs with advanced audio in the US East (N. Virginia) Region:'. Below this, under the heading 'Input', it lists two items: '1080p HD, HEVC, 20Mbps = \$0.600 per hour' and '1080p HD, HEVC, 20Mbps = \$0.600 per hour'.

*AWS Elemental MediaLive Pricing*, AWS DOCUMENTATION, available at: <https://aws.amazon.com/medialive/pricing/>

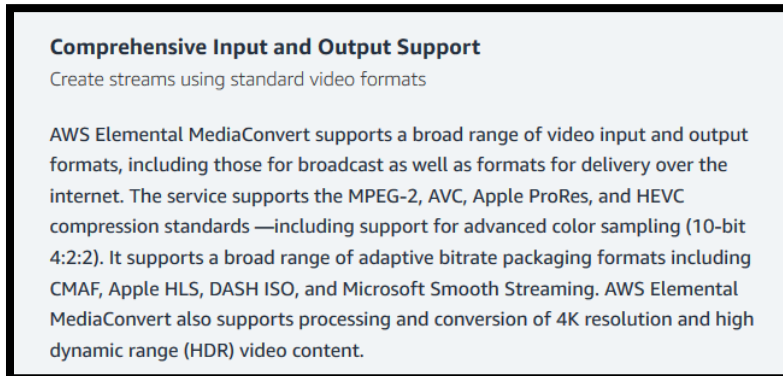

The screenshot shows a section titled 'Comprehensive Input and Output Support' with the sub-heading 'Create streams using standard video formats'. The text below reads: 'AWS Elemental MediaConvert supports a broad range of video input and output formats, including those for broadcast as well as formats for delivery over the internet. The service supports the MPEG-2, AVC, Apple ProRes, and HEVC compression standards—including support for advanced color sampling (10-bit 4:2:2). It supports a broad range of adaptive bitrate packaging formats including CMAF, Apple HLS, DASH ISO, and Microsoft Smooth Streaming. AWS Elemental MediaConvert also supports processing and conversion of 4K resolution and high dynamic range (HDR) video content.'

*AWS Elemental MediaConvert*, AWS DOCUMENTATION, available at: <https://aws.amazon.com/mediaconvert/features/> (AWS Elemental MediaConvert supports a broad range of video input and output formats . . . [t]he service supports . . . HEVC compression standards.”).

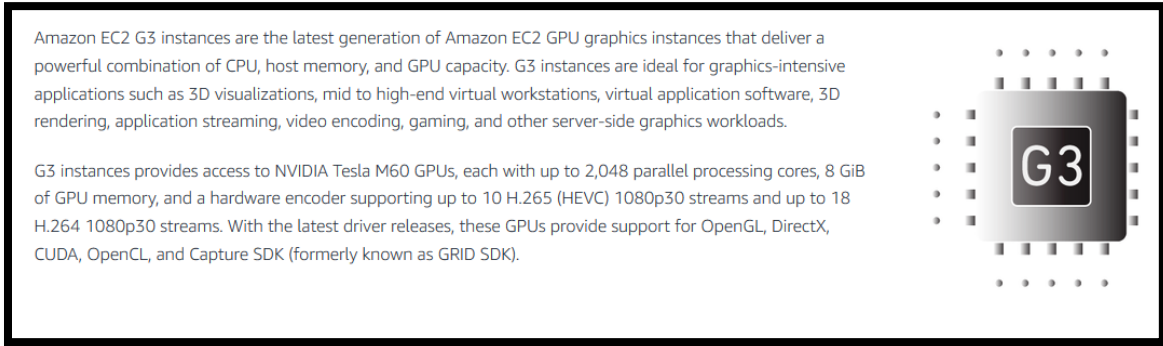

*Amazon EC2 G3 Instances, AWS DOCUMENTATION, available at: <https://aws.amazon.com/ec2/instance-types/g3/> (“G3 instances provides access to NVIDIA Tesla M60 GPUs, each with up to 2,048 parallel processing cores, 8 GiB of GPU memory, and a hardware encoder supporting up to 10 H.265 (HEVC) 1080p30 streams and up to 18 H.264 1080p30 streams.”).*

315. The accused Amazon Fire TV Products (e.g., Fire TV Stick 4k, Fire TV Cube, Fire TV (Gen 3), Fire TV (Gen 2), Fire TV Edition - Toshiba 4K (2018), Fire TV Edition - Element 4K (2018), Fire TV Edition - Insignia HD (2018), Fire TV Edition - Insignia 4k (2018), Fire TV Edition - Toshiba HD (2018)) comply with the HEVC image processing standard. The below excerpt from Amazon Fire TV Developer documentation describes the accused Amazon Fire TV Products as complying with the requirements of the HEVC standard.

Fire TV Stick 4K			
Type	Codec	MIME type	Details
Video	H.265 (HEVC) (High Efficiency Video Coding)	video/hevc	Hardware accelerated up to 3840x2160p (4K) @ 60fps, 35 Mbps, Main 10 Profile Level 5.1, Color space 8-bit and 10-bit input with HDR10, HDR10+, HLG, and Dolby Vision support in rendering pipelines.

*Device Specifications for Fire TV, AMAZON DEVELOPER DOCUMENTATION, available at: <https://developer.amazon.com/docs/fire-tv/device-specifications.html> (describing the HEVC encoding and decoding support for the Amazon Fire TV Products).*

316. The accused Amazon Fire Tablet Products (e.g., Fire HD 8 (2018), Fire HD 10 (2017), Fire HD 8 (2017), Fire 7 (2017), Fire HD 8 (2016), Fire HD 8 (2015), Fire HD 10 (2015)) comply with the HEVC image processing standard. The below excerpt from Amazon Fire Tablet



Developer documentation describes the accused Amazon Fire Tablet Products as complying with the requirements of the HEVC standard.

H.264 AVC	D (HW) High profile, L4.1 1080p@30FPS, E (HW)	D (HW) High profile, L4.1 Main Profile@L4 1080p@30FPS/4 0Mbps, E (HW)	D (HW) High profile, L4.1 Main Profile@L4 1080p@30FPS/4 0Mbps, E (HW)	D (HW) High profile, L4.1 1080p@30FPS, E (HW)
H.265 HEVC	D(HW) Main Profile L4 1080p@30FPS	D (HW) Main Profile L4 Main Profile@L4 1080p@30FPS/4 0Mbps	D (HW) Main Profile L4 Main Profile@L4 1080p@30FPS/4 0Mbps	D(HW) Main Profile L4 1080p@30FPS

*Amazon Fire TV Tablet Media Specifications*, AMAZON DEVELOPER DOCUMENTATION, available at: <https://developer.amazon.com/docs/fire-tablets/ft-media-specs-custom.html> (showing that the Fire HD 8 (2018), Fire HD 10 (2017), Fire HD 8 (2017) and Fire 7 (2017) support H.265 encoding compliant with the standard).

317. On information and belief, by complying with the HEVC standard, the Amazon devices – such as the Amazon ‘529 Products – necessarily infringe the ‘529 patent. Mandatory sections of the HEVC standard require the elements required by certain claims of the ‘529 patent, including but not limited to claim 1. *High Efficiency Video Coding*, SERIES H: AUDIOVISUAL AND Multimedia SYSTEMS: INFRASTRUCTURE OF AUDIOVISUAL SERVICES – CODING OF MOVING VIDEO REC. ITU-T H.265 (February 2018). The following sections of the HEVC Standard are relevant to Amazon’s infringement of the ‘529 patent: “3.110 Prediction Unit Definition;” “6.3.2 Block and quadtree structures;” “6.3.3 Spatial or component-wise partitioning;” “6.4.2 Derivation process for prediction block availability;” “7.3.8.5 Coding unit syntax;” “7.3.8.6 Prediction unit syntax;” “8.3.2 Decoding process for reference picture set;” “8.5.4 Decoding process for the residual signal of coding units coded in inter prediction mode;” “8.6 Scaling, transformation and array construction process prior to deblocking filter process;” “8.5.2 Inter prediction process;”

“8.5.3 Decoding process for prediction units in inter prediction mode;” and “8.7.2 Deblocking filter process.”

318. On information and belief, the Amazon ‘529 Products comply with the HEVC standard, which requires determining motion vectors assigned to individual image regions of an image.

The decoding process for prediction units in inter prediction mode consists of the following ordered steps:

1. The derivation process for motion vector components and reference indices as specified in clause 8.5.3.2 is invoked with the luma coding block location (  $x_{Cb}$ ,  $y_{Cb}$  ), the luma prediction block location (  $x_{B1}$ ,  $y_{B1}$  ), the luma coding block size block  $n_{CbS}$ , the luma prediction block width  $n_{PbW}$ , the luma prediction block height  $n_{PbH}$  and the prediction unit index  $partIdx$  as inputs, and the luma motion vectors  $mvL0$  and  $mvL1$ , when  $ChromaArrayType$  is not equal to 0, the chroma motion vectors  $mvCL0$  and  $mvCL1$ , the reference indices  $refIdxL0$  and  $refIdxL1$  and the prediction list utilization flags  $predFlagL0$  and  $predFlagL1$  as outputs.

*High Efficiency Video Coding, Series H: Audiovisual And Multimedia Systems: Infrastructure Of Audiovisual Services – Coding Of Moving Video Rec. ITU-T H.265 at § 8.5.3.1 (February 2018).*

319. On information and belief, Amazon has directly infringed and continues to directly infringe the ‘529 patent by, among other things, making, using, offering for sale, and/or selling technology for implementing a motion estimation technique that assigns at least one motion vector to each of the image blocks and generating a modification motion vector for at least the first image block.

320. On information and belief, the encoded video stream received by the Amazon ‘529 Products is encoded using inter-picture prediction that makes use of the temporal correlation between pictures to derive a motion-compensated prediction (MCP) for a block of image samples. For this block-based motion compensated prediction, a video picture is divided into rectangular blocks. Assuming homogeneous motion inside one block, and that moving objects are larger than one block, for each block, a corresponding block in a previously decoded picture can be found that

serves as a predictor. The general concept of inter-frame-based encoding using motion-compensated prediction based on a translational motion model is illustrated below.

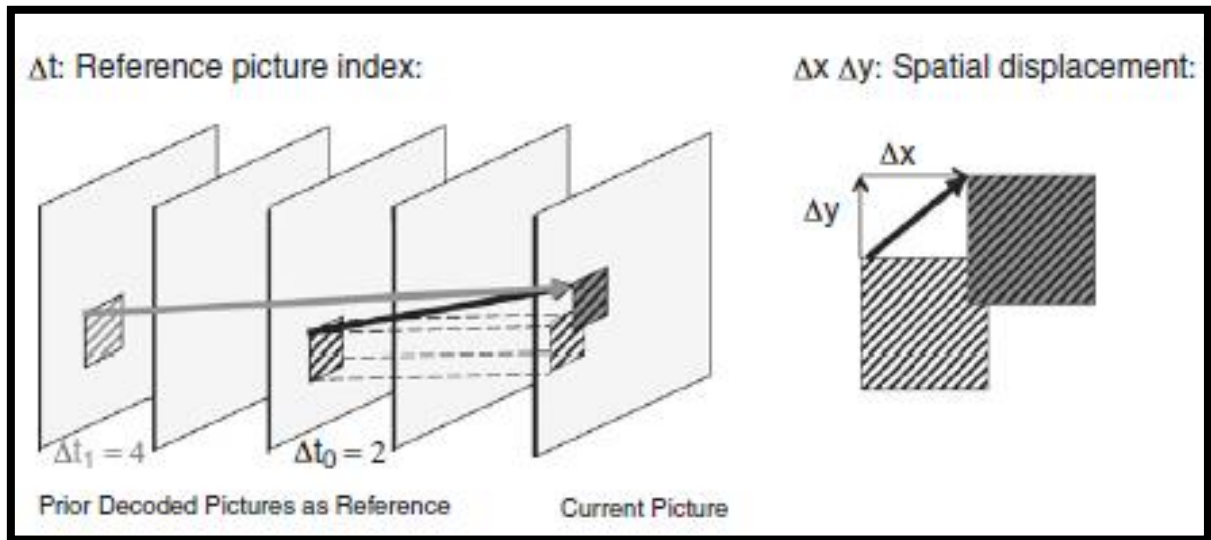

Benjamin Bross, *Inter-Picture Prediction In HEVC*, HIGH EFFICIENCY VIDEO CODING (HEVC) (Vivienne Sze, Madhukar Budagavi, and Gary J. Sullivan (Editors)) at 114 (September 2014).

321. On information and belief, the Amazon '529 Products perform the step of selecting a second image block where the motion vector that is assigned to the first image block passes. Specifically, the Amazon '529 Products, in the use of inter-picture prediction, look at two or more blocks in different frames wherein the vector passes through both the first and second image block. The following excerpts from documentation relating the video estimation technique used by the Amazon '529 Products explains how HEVC uses motion estimation to determine a temporal intermediate position between two images wherein two image blocks are selected that have a motion vector passing in both the first and second image block.

One way of achieving high video compression is to predict pixel values for a frame based on prior and succeeding pictures in the video. Like its predecessors, H.265 features the ability to predict pixel values between pictures, and in particular, to specify in which order pictures are coded and which pictures are predicted from which. The coding order is specified for Groups Of Pictures (GOP), where a number of pictures are grouped together and predicted from each other in a

specified order. The pictures available to predict from, called reference pictures, are specified for every individual picture.

Johan Bartelmeß, *Compression Efficiency of Different Picture Coding Structures in High Efficiency Video Coding (HEVC)*, UPTEC STS 16006 at 4 (March 2016) (emphasis added).

322. On information and belief, the Amazon ‘529 Products receive encoded video data that is encoded using inter-frame coding. Specifically, the encoded video stream received by the Amazon ‘529 Products is coded using its predecessor frame. Inter-prediction used in the encoded video data received by the Amazon ‘529 Products allows a transform block to span across multiple prediction blocks for inter-picture predicted coding units to maximize the potential coding efficiency benefits of the quadtree-structured transform block partitioning.

The basic source-coding algorithm is a hybrid of interpicture prediction to exploit temporal statistical dependences, intrapicture prediction to exploit spatial statistical dependences, and transform coding of the prediction residual signals to further exploit spatial statistical dependences.

G. J. Sullivan, J.-R. Ohm, W.-J. Han, and T. Wiegand, *Overview of the High Efficiency Video Coding (HEVC) standard*, IEEE TRANS. CIRCUITS SYST. VIDEO TECHNOL., Vol. 22, No. 12, p. 1654 (December 2012) (emphasis added).

323. The following excerpt from an article describing the architecture of the video stream received by the Amazon ‘529 Products describes the functionality wherein the second encoded frame of the video data is dependent on the encoding of a first frame. “HEVC inter prediction uses motion vectors pointing to one reference frame . . . to predict a block of pixels.”

HEVC inter prediction uses motion vectors pointing to one reference frame (uni-prediction) or two reference frames (bi-prediction) to predict a block of pixels. The size of the predicted block, called Prediction Unit (PU), is determined by the Coding Unit (CU) size and its partitioning mode. For example, a  $32 \times 32$  CU with  $2N \times N$  partitioning is split into two PUs of size  $32 \times 16$ , or a  $16 \times 16$  CU with  $nL \times 2N$  partitioning is split into  $4 \times 16$  and  $12 \times 16$  PUs.

Mehul Tikekar, *et al.*, *Decoder Hardware Architecture for HEVC*, HIGH EFFICIENCY VIDEO CODING (HEVC) (Vivienne Sze, Madhukar Budagavi, and Gary J. Sullivan (Editors)) (September 2014).

324. Further, the following diagram shows how the Amazon Products receive video data encoded using inter-frame prediction. Specifically, interframe prediction generates a motion vector based on the motion estimation across a first and second frame. The Overview of Design Characteristics for HEVC encoded video data describes the use of “motion vectors for block-based inter prediction to exploit temporal statistical dependencies between frames.”

compression. Encoding algorithms (not specified in this Recommendation | International Standard) may select between inter and intra coding for block-shaped regions of each picture. Inter coding uses motion vectors for block-based inter prediction to exploit temporal statistical dependencies between different pictures. Intra coding uses various spatial prediction modes to exploit spatial statistical dependencies in the source signal for a single picture. Motion vectors and intra prediction modes may be specified for a variety of block sizes in the picture. The prediction residual may then be further compressed using a transform to remove spatial correlation inside the transform block before it is quantized, producing a possibly irreversible process that typically discards less important visual information while forming a close approximation to the source samples. Finally, the motion vectors or intra prediction modes may also be further compressed using a variety of prediction mechanisms, and, after prediction, are combined with the quantized transform coefficient information and encoded using arithmetic coding.

*High Efficiency Video Coding, Series H: Audiovisual And Multimedia Systems: Infrastructure Of Audiovisual Services – Coding Of Moving Video Rec. ITU-T H.265 at § 0.7 (April 2015) (annotation added).*

325. On information and belief, any implementation of the HEVC standard infringes the ‘529 patent as every possible implementation of the standard requires: determining at least a second image block through which the motion vector assigned to the first image block at least partially passes; generating the modified motion vector as a function of a motion vector assigned to at least the second image block; and assigning the modified motion vector as the motion vector to the first image block. Further, the functionality of the motion estimation process in HEVC uses “motion vector[s]: A two-dimensional vector used for *inter prediction* that provides an offset from the coordinates in the decoded picture to the coordinates in a reference picture,” as defined in definition 3.83 of the *ITU-T H.265 Series H: Audiovisual and Multimedia Systems* (2018) (emphasis added); *see also, e.g.*, Gary J. Sullivan, Jens-Rainer Ohm, Woo-Jin Han, and Thomas Wiegand, *Overview of the High Efficiency Video Coding (HEVC) Standard*, published in IEEE TRANSACTIONS ON CIRCUITS AND SYSTEMS FOR VIDEO TECHNOLOGY, Vol. 22, No. 12 at 1650

(December 2012) (“The encoder and decoder generate identical inter picture prediction signals by applying motion compensation (MC) using the MV and mode decision data.”).

326. The following excerpt from a book describes that the motion estimation is done through PU matching method and that the MV represents the displacement between the current PU in the current frame and the matching PU in the reference frame.

Motion estimation compares the current prediction unit (PU) with the spatially neighboring PUs in the reference frames, and chooses the one with the least difference to the current PU. The displacement between the current PU and the matching PU in the reference frames is signaled using a motion vector.

Sung-Fang Tsai, *et al.*, *Encoder Hardware Architecture for HEVC*, HIGH EFFICIENCY VIDEO CODING (HEVC) (Vivienne Sze, Madhukar Budagavi, and Gary J. Sullivan (Editors)) at 347 (September 2014) (emphasis added).

327. On information and belief, the Amazon ‘529 Products perform the step of assigning the modified motion vector as the motion vector to the first image block. Specifically, the Amazon ‘529 Products, through the use of AMVP and Merge Mode, select the modified motion vector and assign it to a first block. The displacement between the current prediction unit and the matching prediction unit in the second image (reference image) is signaled using a motion vector. Further, the Amazon ‘529 Products take the modified motion vector “computed from corresponding regions of previously decoded pictures” and transmit the residual.

A block-wise prediction residual *is computed from corresponding regions of previously decoded pictures (inter-picture motion compensated prediction) or neighboring previously decoded samples from the same picture (intra-picture spatial prediction)*. The residual is then processed by a block transform, and the transform coefficients are quantized and entropy coded. Side information data such as motion vectors and mode switching parameters are also encoded and transmitted.

*Standardized Extensions of High Efficiency Video Coding (HEVC)*, IEEE JOURNAL OF SELECTED TOPICS IN SIGNAL PROCESSING, Vol. 7, No. 6 at 1002 (December 2013) (emphasis added).

328. On information and belief, the Amazon ‘529 Products transmit into the bitstream the candidate index of motion vectors. HEVC documentation states that the coding process will



“pick up the MV [motion vector] to use as an estimator using the index sent by the encoder in the bitstream.”

#### **Inter prediction**

For motion vector prediction HEVC has two reference lists: L0 and L1. They can hold 16 references each, but the maximum total number of unique pictures is 8. Multiple instances of the same ref frame can be stored with different weights. HEVC motion estimation is much more complex than in AVC. It uses list indexing. There are two main prediction modes: Merge and Advanced MV. Each PU can use one of those methods and can have forward (a MV) or bi-directional prediction (2 MV). In Advanced MV mode a list of candidates MV is created (spatial and temporal candidates picked with a complex, probabilistic logic), when the list is created only the best candidate index is transmitted in the bitstream plus the MV delta (the difference between the real MV and the prediction). On the other side, the decoder will build and update continuously the same candidate list using the exact same rules used by the encoder and will pick-up the MV to use as estimator using the index sent by the encoder in the bitstream. The merge mode is similar, the main difference is that the candidates' list is calculated from neighboring MV and is not added to a delta MV. It is the equivalent of "skip" mode in AVC.

Fabio Sonnati, *H265 – Part I: Technical Overview*, VIDEO ENCODING & STREAMING TECHNOLOGIES WEBSITE (June 20, 2014) (emphasis added).

329. On information and belief, Amazon has directly infringed and continues to directly infringe the ‘529 patent by, among other things, making, using, offering for sale, and/or selling technology for determining motion vectors that are each assigned to individual image regions, including but not limited to the Amazon ‘529 Products.

330. On information and belief, the Amazon ‘529 Products are available to businesses and individuals throughout the United States.

331. On information and belief, the Amazon ‘529 Products are provided to businesses and individuals located in the Eastern District of Texas.

332. By making, using, testing, offering for sale, and/or selling products and services for interpolating a pixel during the interlacing of a video signal, including but not limited to the Amazon ‘529 Products, Amazon has injured Dynamic Data and is liable to the Plaintiff for directly infringing one or more claims of the ‘529 patent, including at least claim 1 pursuant to 35 U.S.C. § 271(a).

333. On information and belief, Amazon also indirectly infringes the ‘529 patent by actively inducing infringement under 35 U.S.C. § 271(b).

334. Amazon has had knowledge of the ‘529 patent since at least service of the Original Complaint in this case or shortly thereafter, and on information and belief, Amazon knew of the ‘529 patent and knew of its infringement, including by way of this lawsuit.

335. On information and belief, Amazon intended to induce patent infringement by third-party customers and users of the Amazon ‘529 Products and had knowledge that the inducing acts would cause infringement or was willfully blind to the possibility that its inducing acts would cause infringement. Amazon specifically intended and was aware that the normal and customary use of the accused products would infringe the ‘529 patent. Amazon performed the acts that constitute induced infringement, and would induce actual infringement, with knowledge of the ‘529 patent and with the knowledge that the induced acts would constitute infringement. For example, Amazon provides the Amazon ‘529 Products that have the capability of operating in a manner that infringe one or more of the claims of the ‘529 patent, including at least claim 1, and Amazon further provides documentation and training materials that cause customers and end users of the Amazon ‘529 Products to utilize the products in a manner that directly infringe one or more claims of the ‘529 patent.<sup>31</sup> By providing instruction and training to customers and end-users on how to use the Amazon ‘529 Products in a manner that directly infringes one or more claims of the ‘529 patent, including at least claim 1, Amazon specifically intended to induce infringement

---

<sup>31</sup> See, e.g., *Amazon Elastic Transcoder*, DEVELOPER GUIDE API VERSION 2012-09-25 (Nov. 17, 2016); *Amazon Web Services*, GENERAL REFERENCE VERSION 1.0 (2018); Lee Atkinson, *Delivering Media & Entertainment using the AWS Cloud*, AWS TRANSFORMATION DAY GERMANY PRESENTATION (Oct. 25, 2017); *Fire TV Stick*, AMAZON USER GUIDE; *Watching Video in 4K Ultra HD on Fire TV*, AMAZON HELP WEBSITE, available at: <https://www.amazon.com/gp/help/customer/display.html?nodeId=201859000> (last visited Nov. 2018); *Amazon Fire TV*, AMAZON USER GUIDE.



of the '529 patent. On information and belief, Amazon engaged in such inducement to promote the sales of the Amazon '529 Products, e.g., through Amazon user manuals, product support, marketing materials, and training materials to actively induce the users of the accused products to infringe the '529 patent. Accordingly, Amazon has induced and continues to induce users of the accused products to use the accused products in their ordinary and customary way to infringe the '529 patent, knowing that such use constitutes infringement of the '529 patent.

336. The '529 patent is well-known within the industry as demonstrated by multiple citations to the '529 patent in published patents and patent applications assigned to technology companies and academic institutions. Amazon is utilizing the technology claimed in the '529 patent without paying a reasonable royalty. Amazon is infringing the '529 patent in a manner best described as willful, wanton, malicious, in bad faith, deliberate, consciously wrongful, flagrant, or characteristic of a pirate.

337. To the extent applicable, the requirements of 35 U.S.C. § 287(a) have been met with respect to the '529 patent.

338. As a result of Amazon's infringement of the '529 patent, Dynamic Data has suffered monetary damages, and seeks recovery in an amount adequate to compensate for Amazon's infringement, but in no event less than a reasonable royalty for the use made of the invention by Amazon together with interest and costs as fixed by the Court.

**COUNT VIII**  
**INFRINGEMENT OF U.S. PATENT NO. 7,519,230**

339. Dynamic Data references and incorporates by reference the preceding paragraphs of this Complaint as if fully set forth herein.

340. Amazon designs, makes, uses, sells, and/or offers for sale in the United States products and/or services for selecting a background motion vector for a pixel in an occlusion region of an image.

341. Amazon designs, makes, sells, offers to sell, imports, and/or uses Amazon products that implement the VP9 data processing standard, including: the Amazon Web Services platform (e.g., AWS Elastic Transcoder) and Amazon Fire TVs (e.g., Fire TV Stick 4k) (collectively, the “Amazon ‘230 Product(s)’”).

342. The accused Amazon ‘230 Products comply with the VP9 standard. The below excerpt from documentation regarding the AWS Elastic Transcoder shows that it supports transcoding into VP9 format content.

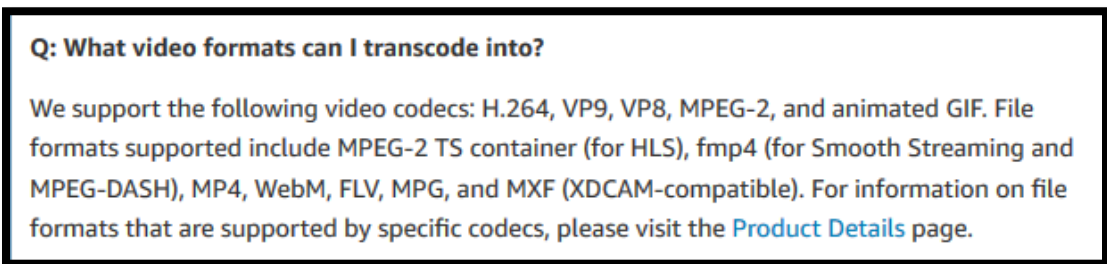

*Amazon Elastic Transcoder FAQs*, AMAZON AWS DOCUMENTATION, available at: <https://aws.amazon.com/elastictranscoder/faqs/> (“We support the following video codecs: H.264, VP9 . . .”).

343. The ability to encode video and image content in compliance with the VP9 standard is described in Amazon documentation as a reason why one needs to use Amazon Elastic Transcoder.

**Why should you stay on Amazon Elastic Transcoder?**

For the small set of features listed below, you still need to use Amazon Elastic Transcoder.

These features are:

- WebM (VP8/VP9) input and output
- Animated GIF output
- MP4 auto-rotation flag support
- MP3, FLAC, Vorbis, and WAV audio-only output
- Encryption support using KMS integration

Jeremy Johnson, *How to Migrate Workflows from Amazon Elastic Transcoder to AWS Elemental MediaConvert*, AMAZON AWS DOCUMENTATION (June 26, 2018), available at: <https://aws.amazon.com/blogs/media/how-to-migrate-workflows-from-amazon-elastic-transcoder-to-aws-elemental-mediaconvert/>

344. The Amazon Fire TV Stick 4K enables the output of VP9 encoded content at up to 60 frames per second.

**4K Specifications**

Specifications related to 4K features are provided in the table below. (This section appears only for 4K-capable devices.)

Fire TV Stick 4K

Item	Details
Resolution and Refresh Rate	- HEVC 4K UHD up to 60 fps - AVC 4K UHD up to 60 fps - VP9 4K UHD up to 60 fps

*Device Specifications for Fire TV*, AMAZON DEVELOPER DOCUMENTATION, available at: <https://developer.amazon.com/docs/fire-tv/device-specifications.html>

345. On information and belief, one or more Amazon subsidiaries and/or affiliates use the Amazon ‘230 Products in regular business operations.

346. On information and belief, one or more of the Amazon ‘230 Products include technology for selecting a background motion vector for a pixel in an occlusion region of an image.

347. On information and belief, the Amazon ‘230 Products are available to businesses and individuals throughout the United States.

348. On information and belief, the Amazon ‘230 Products are provided to businesses and individuals located in the Eastern District of Texas.

349. On information and belief, Amazon has directly infringed and continues to directly infringe the ‘230 patent by, among other things, making, using, offering for sale, and/or selling technology for selecting a background motion vector for a pixel in an occlusion region of an image, including but not limited to the Amazon ‘230 Products.

In the reference implementation, segmentation is currently used to identify background and foreground areas in encoded video content. The (static) background is then coded at a higher quality compared to the rest of the frame in certain reference frames (such as the alt-ref frame) that provides prediction that persists over a number of frames. In contrast, for the frames between these persistent reference frames, the background is given fewer bits by, for example, restricting the set of available reference buffers, using only the ZERO\_MV coding mode, or skipping the residual coefficient block. The result is that more bits are available to code the foreground-portion of the scene, while still preserving very good perceptual quality on the static background. Other use cases involving spatial and temporal masking for perceptual quality improvement are conceivable.

*A VP9 Bitstream Overview*, NETWORK WORKING GROUP § 2.8 (February 18, 2013).

350. On information and belief, the Amazon ‘230 Products comprise systems and methods for selecting a background motion vector for a pixel in an occlusion region of an image.

351. On information and belief, the Amazon ‘230 Products determine the correct motion vector in occlusion regions, thereby reducing or eliminating artifacts of motion compensated image rate converters, which are referred to as “halos” in the display of video images.

352. On information and belief, the Amazon ‘230 Products perform a method of selecting a background motion vector for a pixel in an occlusion region of an image comprising computing a model-based motion vector for the pixel on basis of a motion model being determined on basis of a part of a motion vector field of the image.

## Coding Tools: Segmentation



- Segmentation feature significantly enhanced in VP9
  - Groups together blocks that share common characteristics into segments.
  - Indicate segmentation id at block level
    - Differentially encode segmentation map temporally
  - Encode control flags/features at segment level.
    - Q, loop filter strength, ref frame, skip mode
  
- Unlocking the true potential requires a smart encoder
  - Syntax provides a framework for encoding innovation
  - Various psychovisual optimizations possible

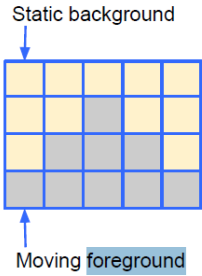

Debargha Mukherjee, A TECHNICAL OVERVIEW OF VP9: THE LATEST ROYALTY FREE VIDEO CODEC FROM GOOGLE (2016)).

353. On information and belief, the Amazon ‘230 Products perform a method of selecting a background motion vector for a pixel in an occlusion region of an image comprising comparing the model-based motion vector with each of the motion vectors of the set of motion vectors.

354. On information and belief, the Amazon ‘230 Products perform a method of selecting a background motion vector for a pixel in an occlusion region of an image comprising selecting a particular motion vector of the set of motion vectors on basis of the comparing and for assigning the particular motion vector as the background motion vector.

355. By making, using, testing, offering for sale, and/or selling products and services, including but not limited to the Amazon ‘230 Products, Amazon has injured Dynamic Data and is liable for directly infringing one or more claims of the ‘230 patent, including at least claim 6, pursuant to 35 U.S.C. § 271(a).

356. On information and belief, Amazon also indirectly infringes the ‘230 patent by actively inducing infringement under 35 U.S.C. § 271(b).

357. On information and belief, Amazon has had knowledge of the ‘230 patent since at least service of the Original Complaint in this case or shortly thereafter, and on information and belief, Amazon knew of the ‘230 patent and knew of its infringement, including by way of this lawsuit.

358. On information and belief, Amazon intended to induce patent infringement by third-party customers and users of the Amazon ‘230 Products and had knowledge that the inducing acts would cause infringement or was willfully blind to the possibility that its inducing acts would cause infringement. Amazon specifically intended and was aware that the normal and customary use of the accused products would infringe the ‘230 patent. Amazon performed the acts that constitute induced infringement, and would induce actual infringement, with knowledge of the ‘230 patent and with the knowledge that the induced acts would constitute infringement. For example, Amazon provides the Amazon ‘230 Products that have the capability of operating in a manner that infringe one or more of the claims of the ‘230 patent, including at least claim 6, and Amazon further provides documentation and training materials that cause customers and end users of the Amazon ‘230 Products to utilize the products in a manner that directly infringe one or more claims of the ‘230 patent.<sup>32</sup> By providing instruction and training to customers and end-users on

---

<sup>32</sup> See, e.g., *Amazon Elastic Transcoder*, DEVELOPER GUIDE API VERSION 2012-09-25 (Nov. 17, 2016); *Amazon Web Services*, GENERAL REFERENCE VERSION 1.0 (2018); Lee Atkinson, *Delivering Media & Entertainment using the AWS Cloud*, AWS TRANSFORMATION DAY GERMANY PRESENTATION (Oct. 25, 2017); *Fire TV Stick*, AMAZON USER GUIDE; *Watching Video in 4K Ultra HD on Fire TV*, AMAZON HELP WEBSITE, available at: <https://www.amazon.com/gp/help/customer/display.html?nodeId=201859000> (last visited Nov. 2018); *Amazon Fire TV*, AMAZON USER GUIDE.

how to use the Amazon '230 Products in a manner that directly infringes one or more claims of the '230 patent, including at least claim 6, Amazon specifically intended to induce infringement of the '230 patent. On information and belief, Amazon engaged in such inducement to promote the sales of the Amazon '230 Products, e.g., through Amazon user manuals, product support, marketing materials, and training materials to actively induce the users of the accused products to infringe the '230 patent. Accordingly, Amazon has induced and continues to induce users of the accused products to use the accused products in their ordinary and customary way to infringe the '230 patent, knowing that such use constitutes infringement of the '230 patent.

359. The '230 patent is well-known within the industry as demonstrated by multiple citations to the '230 patent in published patents and patent applications assigned to technology companies and academic institutions. Amazon is utilizing the technology claimed in the '230 patent without paying a reasonable royalty. Amazon is infringing the '230 patent in a manner best described as willful, wanton, malicious, in bad faith, deliberate, consciously wrongful, flagrant, or characteristic of a pirate.

360. To the extent applicable, the requirements of 35 U.S.C. § 287(a) have been met with respect to the '230 patent.

361. As a result of Amazon's infringement of the '230 patent, Dynamic Data has suffered monetary damages, and seeks recovery in an amount adequate to compensate for Amazon's infringement, but in no event less than a reasonable royalty for the use made of the invention by Amazon together with interest and costs as fixed by the Court.

**COUNT IX**  
**INFRINGEMENT OF U.S. PATENT NO. 7,571,450**

362. Dynamic Data references and incorporates by reference the preceding paragraphs of this Complaint as if fully set forth herein.

363. Amazon designs, makes, uses, sells, and/or offers for sale in the United States products and/or services for displaying information.

364. Amazon designs, makes, sells, offers to sell, imports, and/or uses Amazon products capable of decoding video data in compliance with the H.265 standard. By way of example, the following Amazon Products perform decoding pursuant to the H.265 standard: the Amazon Web Services platform (e.g., AWS Elastic Transcoder, AWS Elemental MediaConvert, AWS Elemental MediaLive, Amazon CloudFront); Amazon Fire TV products (e.g., Fire TV Stick 4k, Fire TV Cube, Fire TV (Gen 3), Fire TV (Gen 2), Fire TV Edition - Toshiba 4K (2018), Fire TV Edition - Element 4K (2018), Fire TV Edition - Insignia HD (2018), Fire TV Edition - Insignia 4k (2018), Fire TV Edition - Toshiba HD (2018)); and Amazon Fire Tablet products (e.g., (Fire HD 8 (2018), Fire HD 10 (2017), Fire HD 8 (2017), Fire 7 (2017), Fire HD 8 (2016), Fire (2015), Fire HD 8 (2015), Fire HD 10 (2015), Fire HDX 8.9 (2014), Fire HD 7 (2014), Fire HD 6 (2014), Kindle Fire HDX 8.9 (2013), Kindle Fire HDX (2013), Kindle Fire HD (2013), Kindle Fire HD 8.9 (2012), Kindle Fire HD (2012), Kindle Fire (2012), Kindle Fire (2011)) (collectively, the “Amazon ‘450 Product(s)’”).

365. On information and belief, one or more Amazon subsidiaries and/or affiliates use the Amazon ‘450 Products in regular business operations.

366. The accused Amazon Web Services platform products (e.g., AWS Elastic Transcoder, AWS Elemental MediaConvert, AWS Elemental MediaLive, Amazon EC2 Accelerated Compute (EC2 G3 Instances), and Amazon CloudFront) comply with the HEVC



image processing standard. As shown in the following excerpts from Amazon Documentation the accused Amazon Web Services Platform functionalities comply with the HEVC standard.

Until recently, H.264 (also known as AVC) was the best codec for optimizing quality and reducing file sizes; many content publishers still use it today. But it's quickly giving way to HEVC: High-Efficiency Video Coding. It's also referred to as H.265; different standards groups employ different designations to refer to the same standard. HEVC requires more computing power than H.264, but it's more efficient. Because AWS Elemental writes all of its encoding software from scratch, rather than relying on off-the-shelf encoding software, it is able to take the efficiency gains in each new generation of codec and adjust the software accordingly to get the best quality and/ or smallest video file sizes, along with the shortest encoding times.

Alicia Hunt, *A Video Compression Primer*, AWS MEDIA BLOG (January 30, 2019), available at: <https://aws.amazon.com/blogs/media/a-video-compression-primer/> (emphasis added).

The screenshot shows a pricing table for AWS Elemental MediaLive. It has two tabs: 'Example 1' (selected) and 'Example 2'. The text reads: 'The per hour cost for a live channel with two HD inputs (using input switching) and producing 5 outputs with advanced audio in the US East (N. Virginia) Region:'. Under the heading 'Input', there are two entries: '1080p HD, HEVC, 20Mbps = \$0.600 per hour' and '1080p HD, HEVC, 20Mbps = \$0.600 per hour'.

*AWS Elemental MediaLive Pricing*, AWS DOCUMENTATION, available at: <https://aws.amazon.com/medialive/pricing/>

The screenshot shows a section titled 'Comprehensive Input and Output Support' with the subtext 'Create streams using standard video formats'. The main text states: 'AWS Elemental MediaConvert supports a broad range of video input and output formats, including those for broadcast as well as formats for delivery over the internet. The service supports the MPEG-2, AVC, Apple ProRes, and HEVC compression standards—including support for advanced color sampling (10-bit 4:2:2). It supports a broad range of adaptive bitrate packaging formats including CMAF, Apple HLS, DASH ISO, and Microsoft Smooth Streaming. AWS Elemental MediaConvert also supports processing and conversion of 4K resolution and high dynamic range (HDR) video content.'

*AWS Elemental MediaConvert*, AWS DOCUMENTATION, available at: <https://aws.amazon.com/mediaconvert/features/> (AWS Elemental MediaConvert supports a broad range of video input and output formats . . . [t]he service supports . . . HEVC compression standards.”).

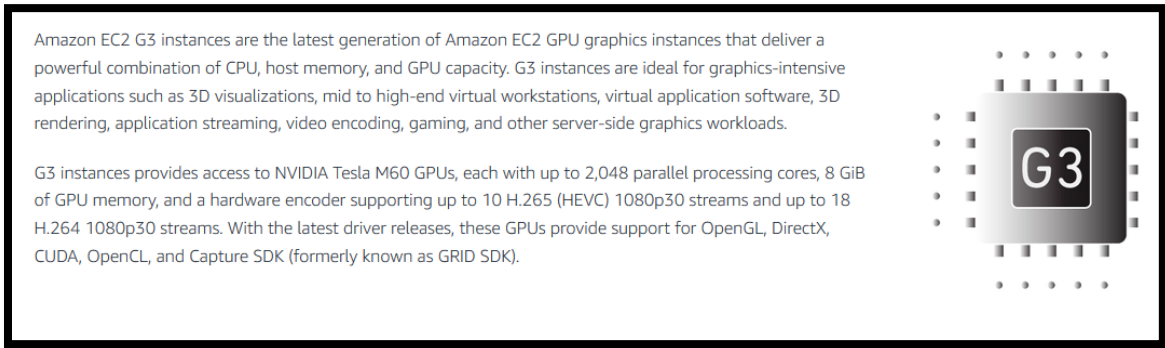

*Amazon EC2 G3 Instances, AWS DOCUMENTATION, available at: <https://aws.amazon.com/ec2/instance-types/g3/> (“G3 instances provides access to NVIDIA Tesla M60 GPUs, each with up to 2,048 parallel processing cores, 8 GiB of GPU memory, and a hardware encoder supporting up to 10 H.265 (HEVC) 1080p30 streams and up to 18 H.264 1080p30 streams.”).*

367. The accused Amazon Fire TV Products (e.g., Fire TV Stick 4k, Fire TV Cube, Fire TV (Gen 3), Fire TV (Gen 2), Fire TV Edition - Toshiba 4K (2018), Fire TV Edition - Element 4K (2018), Fire TV Edition - Insignia HD (2018), Fire TV Edition - Insignia 4k (2018), Fire TV Edition - Toshiba HD (2018)) comply with the HEVC image processing standard. The below excerpt from Amazon Fire TV Developer documentation describes the accused Amazon Fire TV Products as complying with the requirements of the HEVC standard.

Fire TV Stick 4K			
Type	Codec	MIME type	Details
Video	H.265 (HEVC) (High Efficiency Video Coding)	video/hevc	Hardware accelerated up to 3840x2160p (4K) @ 60fps, 35 Mbps, Main 10 Profile Level 5.1, Color space 8-bit and 10-bit input with HDR10, HDR10+, HLG, and Dolby Vision support in rendering pipelines.

*Device Specifications for Fire TV, AMAZON DEVELOPER DOCUMENTATION, available at: <https://developer.amazon.com/docs/fire-tv/device-specifications.html> (describing the HEVC encoding and decoding support for the Amazon Fire TV Products).*

368. The accused Amazon Fire Tablet Products (e.g., Fire HD 8 (2018), Fire HD 10 (2017), Fire HD 8 (2017), Fire 7 (2017), Fire HD 8 (2016), Fire HD 8 (2015), Fire HD 10 (2015)) comply with the HEVC image processing standard. The below excerpt from Amazon Fire Tablet

Developer documentation describes the accused Amazon Fire Tablet Products as complying with the requirements of the HEVC standard.

H.264 AVC	D (HW) High profile, L4.1 1080p@30FPS, E (HW)	D (HW) High profile, L4.1 Main Profile@L4 1080p@30FPS/4 0Mbps, E (HW)	D (HW) High profile, L4.1 Main Profile@L4 1080p@30FPS/4 0Mbps, E (HW)	D (HW) High profile, L4.1 1080p@30FPS, E (HW)
H.265 HEVC	D(HW) Main Profile L4 1080p@30FPS	D (HW) Main Profile L4 Main Profile@L4 1080p@30FPS/4 0Mbps	D (HW) Main Profile L4 Main Profile@L4 1080p@30FPS/4 0Mbps	D(HW) Main Profile L4 1080p@30FPS

*Amazon Fire TV Tablet Media Specifications*, AMAZON DEVELOPER DOCUMENTATION, available at: <https://developer.amazon.com/docs/fire-tablets/ft-media-specs-custom.html> (showing that the Fire HD 8 (2018), Fire HD 10 (2017), Fire HD 8 (2017) and Fire 7 (2017) support H.265 encoding compliant with the standard).

369. On information and belief, by complying with the HEVC standard, the Amazon devices – such as the Amazon ‘450 Products – necessarily infringe the ‘450 patent. Mandatory sections of the HEVC standard require the elements required by certain claims of the ‘450 patent, including but not limited to claim 8. *High Efficiency Video Coding*, SERIES H: AUDIOVISUAL AND Multimedia SYSTEMS: INFRASTRUCTURE OF AUDIOVISUAL SERVICES – CODING OF MOVING VIDEO REC. ITU-T H.265 (February 2018). The following sections of the HEVC Standard are relevant to Amazon’s infringement of the ‘450 patent: “5.3 Logical operators;” “5.10 Variables, syntax elements and tables;” “5.11 Text description of logical operations;” “7.2 Specification of syntax functions and descriptors;” “7.3.1 NAL unit syntax;” “7.3.2 Raw byte sequence payloads, trailing bits and byte alignment syntax;” “7.3.5 Supplemental enhancement information message syntax;” “7.4.2 NAL unit semantics;” and “7.4.6 Supplemental enhancement information message semantics.”

370. On information and belief, the Amazon ‘450 Products receive data that is segmented into Network Abstraction Layer (“NAL”) Units. NAL Units are segments of data that can include video data and overlay data (such as captions and overlay images). The Amazon ‘450 Products support the receipt of VCL and non-VCL NAL units. The VCL NAL units contain the data that represents the values of the samples in the video pictures, and the non-VCL NAL units contain any associated additional information such as parameter sets or overlay data.

HEVC uses a NAL unit based bitstream structure. A coded bitstream is partitioned into NAL units which, when conveyed over lossy packet networks, should be smaller than the maximum transfer unit (MTU) size. Each NAL unit consists of a NAL unit header followed by the NAL unit payload. There are two conceptual classes of NAL units. Video coding layer (VCL) NAL units containing coded sample data, e.g., coded slice NAL units, whereas non-VCL NAL units that contain metadata typically belonging to more than one coded picture, or where the association with a single coded picture would be meaningless, such as parameter set NAL units, or where the information is not needed by the decoding process, such as SEI NAL units.

Rickard Sjöberg et al, *Overview of HEVC High-Level Syntax and Reference Picture Management*, IEEE TRANSACTIONS ON CIRCUITS AND SYSTEMS FOR VIDEO TECHNOLOGY, Vol. 22, No. 12 at 1859 (December 2012) (emphasis added).

371. The Amazon ‘450 Products process data in the form of VCL NAL Units that contain segments of data which are used to generate an image (e.g., HEVC image) on a display device. Each VCL NAL Unit comprises a discrete number of bites which make up a segment. The following excerpt from the HEVC specification describes a NAL unit as being a segment with a “demarcation” setting forth where the segment ends and begins.

NumBytesInNalUnit specifies the size of the NAL unit in bytes. This value is required for decoding of the NAL unit. Some form of demarcation of NAL unit boundaries is necessary to enable inference of NumBytesInNalUnit. One such demarcation method is specified in Annex B for the byte stream format. Other methods of demarcation may be specified outside of this Specification.

*High Efficiency Video Coding*, SERIES H: AUDIOVISUAL AND MULTIMEDIA SYSTEMS: INFRASTRUCTURE OF AUDIOVISUAL SERVICES – CODING OF MOVING VIDEO REC. ITU-T H.265 at § 7.4.2.1 (February 2018) (emphasis added).

372. The Amazon ‘450 Products receive VCL NAL units that contain the data that represents the values of the samples in the video pictures, and non-VCL NAL units that contain associated additional information such as parameter sets or overlay data.

HEVC uses a NAL unit based bitstream structure. A coded bitstream is partitioned into NAL units which, when conveyed over lossy packet networks, should be smaller than the maximum transfer unit (MTU) size. Each NAL unit consists of a NAL unit header followed by the NAL unit payload. There are two conceptual classes of NAL units. Video coding layer (VCL) NAL units containing coded sample data, e.g., coded slice NAL units, whereas non-VCL NAL units that contain metadata typically belonging to more than one coded picture, or where the association with a single coded picture would be meaningless, such as parameter set NAL units, or where the information is not needed by the decoding process, such as SEI NAL units.

Rickard Sjöberg et al, *Overview of HEVC High-Level Syntax and Reference Picture Management*, IEEE TRANSACTIONS ON CIRCUITS AND SYSTEMS FOR VIDEO TECHNOLOGY, Vol. 22, No. 12 at 1859 (December 2012) (emphasis added).

373. The Amazon ‘450 Products perform filtering, wherein the filtering enables a user to select a data element based on the user’s selection. Specifically, a user can select the display of Non-VCL NAL Unit data which can include closed captions or other overlay information that is selected based on the user interaction. The data that is selected by the user is parsed by the system and filtered. The Non-VCL NAL Units include supplemental enhancement information (“SEI”) messages. The SEI data that is received contains overlay information that can be combined with the image data that has already been received.

	Descriptor
sei_message() {	
payloadType = 0	
while( next_bits( 8 ) == 0xFF ) {	
ff_byte /* equal to 0xFF */	f(8)
payloadType += 255	
}	
last_payload_type_byte	u(8)
payloadType += last_payload_type_byte	
payloadSize = 0	
while( next_bits( 8 ) == 0xFF ) {	
ff_byte /* equal to 0xFF */	f(8)
payloadSize += 255	
}	
last_payload_size_byte	u(8)
payloadSize += last_payload_size_byte	
sei_payload( payloadType, payloadSize )	
}	

*High Efficiency Video Coding, SERIES H: AUDIOVISUAL AND MULTIMEDIA SYSTEMS: INFRASTRUCTURE OF AUDIOVISUAL SERVICES – CODING OF MOVING VIDEO REC. ITU-T H.265 at § 7.3.5 (February 2018).*

374. The Amazon ‘450 Products perform rendering of an output image to be displayed on a display device on the basis of the first data-element selected by the filter. The overlay data is used to render overlays of the display data. The amount of overlay data that is downloaded in the form of Non-VCL data comprises a portion of the overlay that is displayed.

375. On information and belief, Amazon has directly infringed and continues to directly infringe the ‘450 patent by, among other things, making, using, offering for sale, and/or selling technology for displaying information, including but not limited to the Amazon ‘450 Products.

376. On information and belief, one or more of the Amazon ‘450 Products enable methods and systems wherein a user does not need to make a new selection after being switched from one service to a second service.

377. On information and belief, one or more of the Amazon ‘450 Products perform a method of displaying information on a display device wherein receiving a transport stream comprises services, with the services having elementary streams of video and of data elements.

378. On information and belief, one or more of the Amazon '450 Products perform a method of displaying information on a display device wherein user actions of making a user selection of a type of information to be displayed on the device are received.

379. On information and belief, one or more of the Amazon '450 Products perform a method of displaying information on a display device wherein filtering to select a data element of a first one of the services on the basis of the user selection is performed.

380. On information and belief, one or more of the Amazon '450 Products perform a method of displaying information on a display device wherein rendering to calculate an output image to be displayed on the display device, on the basis of the first data element selected by the filer is performed.

381. On information and belief, one or more of the Amazon '450 Products perform a method of displaying information on a display device wherein switching from the first one of the services to a second one of the services, characterized in comprising a second step of filtering to select a second data-element of the second one of the services, on the basis of the user selection is performed.

382. On information and belief, one or more of the Amazon '450 Products perform a method of displaying information on a display device wherein being switched from the first one of the services to the second one of the services, with the data-element and the second data-element being mutually semantically related and a second step of rendering to calculate the output image to be displayed on the display device, on the basis of the second data-element selected by the filter is performed.

383. On information and belief, Amazon has directly infringed and continues to directly infringe the '450 patent by, among other things, making, using, offering for sale, and/or selling technology for displaying information, including but not limited to the Amazon '450 Products.

384. On information and belief, the Amazon '450 Products are available to businesses and individuals throughout the United States.

385. On information and belief, the Amazon '450 Products are provided to businesses and individuals located in the Eastern District of Texas.

386. By making, using, testing, offering for sale, and/or selling products and services for displaying information, including but not limited to the Amazon '450 Products, Amazon has injured Dynamic Data and is liable to the Plaintiff for directly infringing one or more claims of the '450 patent, including at least claim 8 pursuant to 35 U.S.C. § 271(a).

387. On information and belief, Amazon also indirectly infringes the '450 patent by actively inducing infringement under 35 U.S.C. § 271(b).

388. Amazon has had knowledge of the '450 patent since at least service of the Original Complaint in this case or shortly thereafter, and on information and belief, Amazon knew of the '450 patent and knew of its infringement, including by way of this lawsuit.

389. On information and belief, Amazon intended to induce patent infringement by third-party customers and users of the Amazon '450 Products and had knowledge that the inducing acts would cause infringement or was willfully blind to the possibility that its inducing acts would cause infringement. Amazon specifically intended and was aware that the normal and customary use of the accused products would infringe the '450 patent. Amazon performed the acts that constitute induced infringement, and would induce actual infringement, with knowledge of the '450 patent and with the knowledge that the induced acts would constitute infringement. For



example, Amazon provides the Amazon ‘450 Products that have the capability of operating in a manner that infringe one or more of the claims of the ‘450 patent, including at least claim 8, and Amazon further provides documentation and training materials that cause customers and end users of the Amazon ‘450 Products to utilize the products in a manner that directly infringe one or more claims of the ‘450 patent.<sup>33</sup> By providing instruction and training to customers and end-users on how to use the Amazon ‘450 Products in a manner that directly infringes one or more claims of the ‘450 patent, including at least claim 8, Amazon specifically intended to induce infringement of the ‘450 patent. On information and belief, Amazon engaged in such inducement to promote the sales of the Amazon ‘450 Products, e.g., through Amazon user manuals, product support, marketing materials, and training materials to actively induce the users of the accused products to infringe the ‘450 patent. Accordingly, Amazon has induced and continues to induce users of the accused products to use the accused products in their ordinary and customary way to infringe the ‘450 patent, knowing that such use constitutes infringement of the ‘450 patent.

390. The ‘450 patent is well-known within the industry as demonstrated by multiple citations to the ‘450 patent in published patents and patent applications assigned to technology companies and academic institutions. Amazon is utilizing the technology claimed in the ‘450 patent without paying a reasonable royalty. Amazon is infringing the ‘450 patent in a manner best

---

<sup>33</sup> See, e.g., *Amazon Elastic Transcoder*, DEVELOPER GUIDE API VERSION 2012-09-25 (Nov. 17, 2016); *Amazon Web Services*, GENERAL REFERENCE VERSION 1.0 (2018); Lee Atkinson, *Delivering Media & Entertainment using the AWS Cloud*, AWS TRANSFORMATION DAY GERMANY PRESENTATION (Oct. 25, 2017); *Fire TV Stick*, AMAZON USER GUIDE; *Watching Video in 4K Ultra HD on Fire TV*, AMAZON HELP WEBSITE, available at: <https://www.amazon.com/gp/help/customer/display.html?nodeId=201859000> (last visited Nov. 2018); *Amazon Fire TV*, AMAZON USER GUIDE; *Amazon Fire Tablet and Kindle E-Reader Quick Setup Guide*, AMAZON USER GUIDE (2014); *Fire & Kindle User’s Guides*, Amazon Help Website, available at: <https://www.amazon.com/gp/help/customer/display.html?nodeId=200317150> (last visited Nov. 2018).

described as willful, wanton, malicious, in bad faith, deliberate, consciously wrongful, flagrant, or characteristic of a pirate.

391. To the extent applicable, the requirements of 35 U.S.C. § 287(a) have been met with respect to the '450 patent.

392. As a result of Amazon's infringement of the '450 patent, Dynamic Data has suffered monetary damages, and seeks recovery in an amount adequate to compensate for Amazon's infringement, but in no event less than a reasonable royalty for the use made of the invention by Amazon together with interest and costs as fixed by the Court.

**COUNT X**  
**INFRINGEMENT OF U.S. PATENT NO. 6,639,944**

393. Dynamic Data references and incorporates by reference the preceding paragraphs of this Complaint as if fully set forth herein.

394. Amazon designs, makes, uses, sells, and/or offers for sale in the United States products and/or services for sub-pixel accurate motion vector estimation and motion-compensated interpolation or prediction.

395. Amazon designs, makes, sells, offers to sell, imports, and/or uses Amazon products capable of decoding video data in compliance with the H.265 standard. By way of example, the following Amazon Products perform decoding pursuant to the H.265 standard: the Amazon Web Services platform (e.g., AWS Elastic Transcoder, AWS Elemental MediaConvert, AWS Elemental MediaLive, Amazon CloudFront); Amazon Fire TV products (e.g., Fire TV Stick 4k, Fire TV Cube, Fire TV (Gen 3), Fire TV (Gen 2), Fire TV Edition - Toshiba 4K (2018), Fire TV Edition - Element 4K (2018), Fire TV Edition - Insignia HD (2018), Fire TV Edition - Insignia 4k (2018), Fire TV Edition - Toshiba HD (2018)); and Amazon Fire Tablet products (e.g., (Fire

HD 8 (2018), Fire HD 10 (2017), Fire HD 8 (2017), Fire 7 (2017), Fire HD 8 (2016), Fire (2015), Fire HD 8 (2015), Fire HD 10 (2015), Fire HDX 8.9 (2014), Fire HD 7 (2014), Fire HD 6 (2014), Kindle Fire HDX 8.9 (2013), Kindle Fire HDX (2013), Kindle Fire HD (2013), Kindle Fire HD 8.9 (2012), Kindle Fire HD (2012), Kindle Fire (2012), Kindle Fire (2011)) (collectively, the “Amazon ‘944 Products”).

396. The accused Amazon Web Services platform products (e.g., AWS Elastic Transcoder, AWS Elemental MediaConvert, AWS Elemental MediaLive, Amazon EC2 Accelerated Compute (EC2 G3 Instances), and Amazon CloudFront) comply with the HEVC image processing standard. As shown in the following excerpts from Amazon Documentation the accused Amazon Web Services Platform functionalities comply with the HEVC standard.

Until recently, H.264 (also known as AVC) was the best codec for optimizing quality and reducing file sizes; many content publishers still use it today. But it’s quickly giving way to HEVC: High-Efficiency Video Coding. It’s also referred to as H.265; different standards groups employ different designations to refer to the same standard. HEVC requires more computing power than H.264, but it’s more efficient. Because AWS Elemental writes all of its encoding software from scratch, rather than relying on off-the-shelf encoding software, it is able to take the efficiency gains in each new generation of codec and adjust the software accordingly to get the best quality and/ or smallest video file sizes, along with the shortest encoding times.

Alicia Hunt, *A Video Compression Primer*, AWS MEDIA BLOG (January 30, 2019), available at: <https://aws.amazon.com/blogs/media/a-video-compression-primer/> (emphasis added).

Example 1	Example 2
<p>The per hour cost for a live channel with two HD inputs (using input switching) and producing 5 outputs with advanced audio in the US East (N. Virginia) Region:</p>	
<p><b>Input</b></p>	
<p>1080p HD, HEVC, 20Mbps = \$0.600 per hour</p>	
<p>1080p HD, HEVC, 20Mbps = \$0.600 per hour</p>	

*AWS Elemental MediaLive Pricing*, AWS DOCUMENTATION, available at: <https://aws.amazon.com/medialive/pricing/>

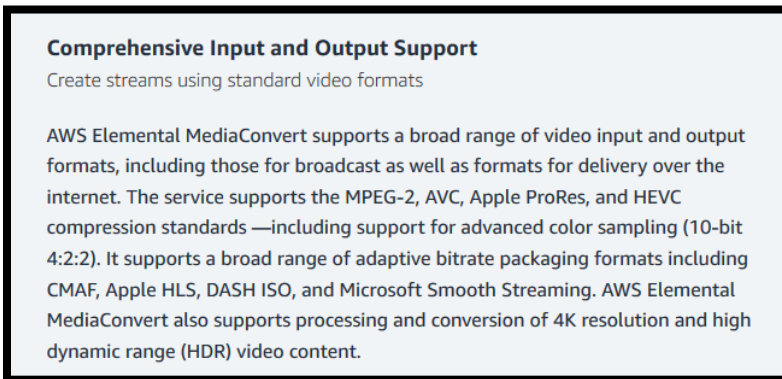

*AWS Elemental MediaConvert, AWS DOCUMENTATION, available at: <https://aws.amazon.com/mediaconvert/features/> (AWS Elemental MediaConvert supports a broad range of video input and output formats . . . [t]he service supports . . . HEVC compression standards.”).*

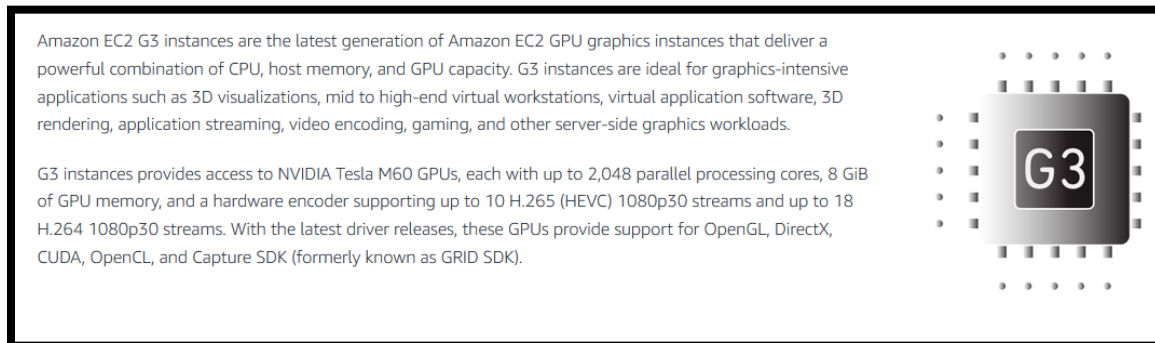

*Amazon EC2 G3 Instances, AWS DOCUMENTATION, available at: <https://aws.amazon.com/ec2/instance-types/g3/> (“G3 instances provides access to NVIDIA Tesla M60 GPUs, each with up to 2,048 parallel processing cores, 8 GiB of GPU memory, and a hardware encoder supporting up to 10 H.265 (HEVC) 1080p30 streams and up to 18 H.264 1080p30 streams.”).*

397. The accused Amazon Fire TV Products (e.g., Fire TV Stick 4k, Fire TV Cube, Fire TV (Gen 3), Fire TV (Gen 2), Fire TV Edition - Toshiba 4K (2018), Fire TV Edition - Element 4K (2018), Fire TV Edition - Insignia HD (2018), Fire TV Edition - Insignia 4k (2018), Fire TV Edition - Toshiba HD (2018)) comply with the HEVC image processing standard. The below excerpt from Amazon Fire TV Developer documentation describes the accused Amazon Fire TV Products as complying with the requirements of the HEVC standard.

Fire TV Stick 4K			
Type	Codec	MIME type	Details
Video	H.265 (HEVC) (High Efficiency Video Coding)	video/hevc	Hardware accelerated up to 3840x2160p (4K) @ 60fps, 35 Mbps, Main 10 Profile Level 5.1, Color space 8-bit and 10-bit input with HDR10, HDR10+, HLG, and Dolby Vision support in rendering pipelines.

*Device Specifications for Fire TV*, AMAZON DEVELOPER DOCUMENTATION, available at: <https://developer.amazon.com/docs/fire-tv/device-specifications.html> (describing the HEVC encoding and decoding support for the Amazon Fire TV Products).

398. The accused Amazon Fire Tablet Products (e.g., Fire HD 8 (2018), Fire HD 10 (2017), Fire HD 8 (2017), Fire 7 (2017), Fire HD 8 (2016), Fire HD 8 (2015), Fire HD 10 (2015)) comply with the HEVC image processing standard. The below excerpt from Amazon Fire Tablet Developer documentation describes the accused Amazon Fire Tablet Products as complying with the requirements of the HEVC standard.

H.264 AVC	D (HW) High profile, L4.1 1080p@30FPS, E (HW)	D (HW) High profile, L4.1 Main Profile@L4 1080p@30FPS/4 0Mbps, E (HW)	D (HW) High profile, L4.1 Main Profile@L4 1080p@30FPS/4 0Mbps, E (HW)	D (HW) High profile, L4.1 1080p@30FPS, E (HW)
H.265 HEVC	D(HW) Main Profile L4 1080p@30FPS	D (HW) Main Profile L4 Main Profile@L4 1080p@30FPS/4 0Mbps	D (HW) Main Profile L4 Main Profile@L4 1080p@30FPS/4 0Mbps	D(HW) Main Profile L4 1080p@30FPS

*Amazon Fire TV Tablet Media Specifications*, AMAZON DEVELOPER DOCUMENTATION, available at: <https://developer.amazon.com/docs/fire-tablets/ft-media-specs-custom.html> (showing that the Fire HD 8 (2018), Fire HD 10 (2017), Fire HD 8 (2017) and Fire 7 (2017) support H.265 encoding compliant with the standard).

399. On information and belief, one or more Amazon subsidiaries and/or affiliates use the Amazon '944 Products in regular business operations.

400. On information and belief, one or more of the Amazon '944 Products include technology for sub-pixel accurate motion vector estimation and motion-compensated interpolation or prediction.

401. On information and belief, one or more Amazon subsidiaries and/or affiliates use the Amazon '944 Products in regular business operations.

402. On information and belief, one or more of the Amazon '944 Products perform a method of generating an intermediate image using sub-pixel accurate motion vectors having vector components that may have non-integer values, from first and second images having a given mutual temporal distance, the intermediate image being at a fractional distance from said first image, said fractional distance being a fraction of said given mutual temporal distance.

403. On information and belief, the Amazon '944 Products comply with the HEVC standard, which requires determining motion vectors assigned to individual image regions of an image.

The decoding process for prediction units in inter prediction mode consists of the following ordered steps:

1. The derivation process for motion vector components and reference indices as specified in clause 8.5.3.2 is invoked with the luma coding block location (  $x_{Cb}$ ,  $y_{Cb}$  ), the luma prediction block location (  $x_{Bl}$ ,  $y_{Bl}$  ), the luma coding block size block  $n_{CbS}$ , the luma prediction block width  $n_{PbW}$ , the luma prediction block height  $n_{PbH}$  and the prediction unit index  $partIdx$  as inputs, and the luma motion vectors  $mvL0$  and  $mvL1$ , when  $ChromaArrayType$  is not equal to 0, the chroma motion vectors  $mvCL0$  and  $mvCL1$ , the reference indices  $refIdxL0$  and  $refIdxL1$  and the prediction list utilization flags  $predFlagL0$  and  $predFlagL1$  as outputs.

*High Efficiency Video Coding, SERIES H: AUDIOVISUAL AND MULTIMEDIA SYSTEMS: INFRASTRUCTURE OF AUDIOVISUAL SERVICES – CODING OF MOVING VIDEO REC. ITU-T H.265 at § 8.5.3.1 (February 2018).*

404. On information and belief, one or more of the Amazon '944 Products perform a method that includes deriving first and second vectors from said sub-pixel accurate motion vectors.

405. On information and belief, one or more of the Amazon '944 Products perform a method that includes generating an intermediate image by combining first positions in a first image shifted over first vectors and second positions in said second image shifted over second vectors.

One way of achieving high video compression is to predict pixel values for a frame based on prior and succeeding pictures in the video. Like its predecessors, H.265 features the ability to predict pixel values between pictures, and in particular, to specify in which order pictures are coded and which pictures are predicted from which. The coding order is specified for Groups Of Pictures (GOP), where a number of pictures are grouped together and predicted from each other in a specified order. The pictures available to predict from, called reference pictures, are specified for every individual picture.

Johan Bartelmeß, Compression Efficiency of Different Picture Coding Structures in High Efficiency Video Coding (HEVC), UPTEC STS 16006 at 4 (March 2016) (emphasis added).

406. On information and belief, one or more of the Amazon '944 Products perform a method that includes deriving first and second vectors from sub-pixel accurate motion vectors by multiplying the vector components of the sub-pixel accurate motion vectors by a fraction to obtain fractional vector components.

three spatially neighboring MVs. HEVC improves the MV prediction by applying an MV prediction competition as initially proposed in [18]. In HEVC, this competition was further adapted to large block sizes with so-called *advanced motion vector prediction* (AMVP) in [19]. In the DIS *Main profile*, AMVP has two predictor candidates competing for the prediction. Two spatial motion vector predictor (MVP) candidates are considered and, when at least one of them is not available or they are redundant, a temporal motion vector prediction (TMVP) candidate is considered. The candidates

Philipp Helle, Simon Oudin, Benjamin Bross, Detlev Marpe, M. Oguz Bici, Kemal Ugur, Joel Jung, Gordon Clare, and Thomas Wiegand, *Block Merging for Quadtree-Based Partitioning in HEVC*, IEEE TRANS. CIR. AND SYS. FOR VIDEO TECHNOLOGY, Vol. 22 No. 12 (December 2012) (“AMVP has two predictor candidates competing for the prediction. Two spatial motion vector predictor (MVP) candidates are considered and, when at least one of them is not available or they are redundant, a temporal motion vector prediction (TMVP) candidate is considered.”).

407. In AMVP, the motion vector selection process is composed by two steps wherein the candidate motion vectors are constructed into an index and then the motion vectors are compared. “In AMVP, the motion vector selection process is composed by two steps in encoder implementation. The first step is the motion vector candidate set construction process and the

second step is the best motion vector selection step. In the first step, the motion vector candidate set is organized by selecting the motion vectors spatially and temporally.” Gwo-Long Li, Chuen-Ching Wang, and Kuang-Hung Chiang, *An Efficient Motion Vector Prediction Method for Avoiding AMVP Data Dependency For HEVC*, 2014 IEEE INTERNATIONAL CONFERENCE ON ACOUSTIC, SPEECH AND SIGNAL PROCESSING (ICASSP) at 7412-13 (2014).

408. On information and belief, one or more of the Amazon '944 Products perform a method that includes deriving first and second vectors from sub-pixel accurate motion vectors by rounding the fractional vector components to obtain vector components of the first vectors, which have only integer vector components.

Using a translational motion model, the position of the block in a previously decoded picture is indicated by a motion vector:  $\Delta x$ ;  $\Delta y$  where  $\Delta x$  specifies the horizontal and  $\Delta y$  the vertical displacement relative to the position of the current block. The motion vectors:  $\Delta x$ ;  $\Delta y$  could be of fractional sample accuracy to more accurately capture the movement of the underlying object. Interpolation is applied on the reference pictures to derive the prediction signal when the corresponding motion vector has fractional sample accuracy. The previously decoded picture is referred to as the reference picture and indicated by a reference index  $\Delta t$  to a reference picture list. These translational motion model parameters, i.e. motion vectors and reference indices, are further referred to as motion data.

Benjamin Bross, *Inter-Picture Prediction In HEVC*, IN HIGH EFFICIENCY VIDEO CODING (HEVC) (Vivienne Sze, Madhukar Budagavi, and Gary J. Sullivan (Editors)) at 114 (September 2014) (emphasis added).

409. On information and belief, one or more of the Amazon '944 Products perform a method that includes deriving first and second vectors from sub-pixel accurate motion vectors by subtracting the first vector from the candidate vector to obtain the second vector, whereby the second vectors have vector components that, depending on the candidate vector and the fraction, may have non-integer values.

410. The Amazon '944 Products contain functionality for motion compensation where two or more motion vectors can be applied. Further, one or two motion vectors can be applied to



the image processing process. The application of the motion vectors leads to uni-predictive or bi-predictive coding, respectively, where bi-predictive coding uses an averaged result of two predictions to form the final prediction.

**Summary**

Recommendation ITU-T H.265 | International Standard ISO/IEC 23008-2 represents an evolution of the existing video coding Recommendations (ITU-T H.261, ITU-T H.262, ITU-T H.263 and ITU-T H.264) and was developed in response to the growing need for higher compression of moving pictures for various applications such as Internet streaming, communication, videoconferencing, digital storage media and television broadcasting. It is also designed to enable the use of the coded video representation in a flexible manner for a wide variety of network environments. The use of this Recommendation | International Standard allows motion video to be manipulated as a form of computer data and to be stored on various storage media, transmitted and received over existing and future networks and distributed on existing and future broadcasting channels.

*Series H: Audiovisual and Multimedia Systems- Infrastructure of Audiovisual Services – Coding of Moving Video*, INTERNATIONAL TELECOMMUNICATIONS UNIONS - TU-T H.265, V.5 at 1 (February 2018).

411. On information and belief, Amazon has directly infringed and continues to directly infringe the '944 patent by, among other things, making, using, offering for sale, and/or selling technology for sub-pixel accurate motion vector estimation and motion-compensated interpolation or prediction, including but not limited to the Amazon '944 Products.

412. The following excerpt from a book describes that the motion estimation is done through PU matching method and that the MV represents the displacement between the current PU in the current frame and the matching PU in the reference frame.

Motion estimation compares the current prediction unit (PU) with the spatially neighboring PUs in the reference frames, and chooses the one with the least difference to the current PU. The displacement between the current PU and the matching PU in the reference frames is signaled using a motion vector.

Sung-Fang Tsai, *et al.*, *Encoder Hardware Architecture for HEVC*, High Efficiency Video Coding (HEVC) at 347 (September 2014) (emphasis added).

413. The following exemplary drawings reflect that the corresponding image segment of a reference picture is co-located with the current image segment of a current picture.

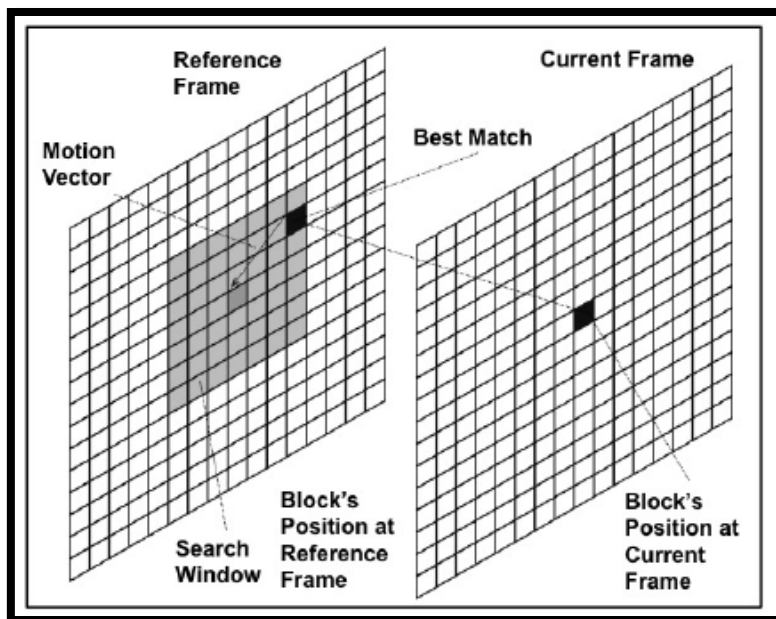

R.C. LINS, *et al.*, *A Faster Pixel-Decimation Method for Block Motion Estimation in H.264/AVC*, PUBLISHED IN TEND. MAT. APL. COMPUT., VOL. 15, No. 1 at 120 (2014), available at: [http://www.scielo.br/scielo.php?script=sci\\_arttext&pid=S2179-84512014000100010](http://www.scielo.br/scielo.php?script=sci_arttext&pid=S2179-84512014000100010).

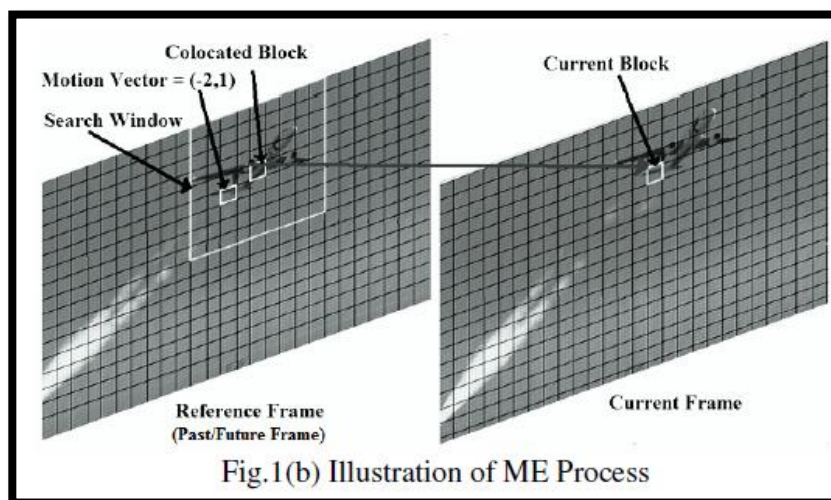

Purnachand Nalluri, *et al.*, *Fast Motion Estimation Algorithm for HEVC Video Encoder*, published in 9TH CONFERENCE ON TELECOMMUNICATIONS, Vol. 1 at 1 (May 2013) (attached hereto as Exhibit\_ZL 5), available at: <https://www.it.pt/Publications/PaperConference/14332>

414. For the AMVP mode with the motion estimation, the main goal of the motion estimation is to find the best matching block of each current PU and determine the real MV which represents the motion translation in the successive frame. The MV difference between the optimal AMVP candidate and the real MV derived from the motion estimation is encoded and transmitted

together with other information, e.g., the optimal AMVP and reference frame indexes. The motion estimation is conducted in two stages, the integer motion estimation (IME) at integer pixel accuracy and the fractional motion estimation (FME) at subpixel accuracy. According to the “High Efficiency Video Coding (HEVC) Test Model 16 (HM 16) Improved Encoder Description Update 9” approved by JCT-VC, the best candidate MVP selected from the AMVP candidate list is used as an initial search center of the IME, which indicates that the search center of the IME is offset from the co-located block within the reference frame by the best candidate MVP.

415. Therefore, when the Amazon Product processes the video data using AMVP mode based on the IME, the co-located block within the reference frame of the current PU corresponds to the selected image segment, and the best candidate MVP corresponds to the offset vector within the reference frame from the co-located block of the current PU (i.e., the selected image segment to the search center.

To derive the motion vector(s) for each PU, a block matching algorithm is performed in the HM encoder. For AMVP, find the best candidate MV predictor for each `ref_idx` and `ref_pic_list` using `xEstimateMvPredAMVP()`, called from `predInterSearch()`. The default search range for the first search in the HM encoder is 96 integer pixels, however the CTC [3] uses a value of 64. A search window is defined according to the search range, relative to the best candidate MV predictor. Firstly an integer-pel search is performed, followed by a fractional-pel refinement search.

The Joint Collaborative Team on Video Coding (JCT-VC), *High Efficiency Video Coding (HEVC) Test Model 16 (HM 16) Improved Encoder Description Update 9*, ISO/IEC JTC1/SC29/WG11 N17047 at 43 (July 2017) (emphasis added), available at: <https://mpeg.chiariglione.org/standards/mpeg-h/high-efficiency-video-coding/n17047-high-efficiency-video-coding-hevc-test-model-16>.

416. On information and belief, by complying with the HEVC standard, the Amazon products – such as the Amazon ‘944 Products – necessarily infringe the ‘944 patent. The mandatory sections of the HEVC standard require the elements required by certain claims of the ‘944 patent, including but not limited to claim 2 of the ‘944 patent. *High Efficiency Video Coding*,

SERIES H: AUDIOVISUAL AND Multimedia SYSTEMS: INFRASTRUCTURE OF AUDIOVISUAL SERVICES  
DYNAMIC DATA FIRST AMENDED COMPLAINT FOR PATENT INFRINGEMENT

– CODING OF MOVING VIDEO REC. ITU-T H.265 (February 2018) (The following sections of the HEVC Standard are relevant to Amazon’s infringement of the ‘944 patent: “8.3.2 Decoding process for reference picture set;” “8.5.4 Decoding process for the residual signal of coding units coded in inter prediction mode;” “8.6 Scaling, transformation and array construction process prior to deblocking filter process;” “8.5.2 Inter prediction process;” “8.5.3 Decoding process for prediction units in inter prediction mode;” and “8.7.2 Deblocking filter process;” “8.7.3 Sample adaptive offset process.”).

417. On information and belief, one or more of the Amazon ‘944 Products perform a method that includes deriving first and second vectors from said sub-pixel accurate motion vectors.

418. On information and belief, one or more of the Amazon ‘944 Products perform a method that includes generating an intermediate image by combining first positions in a first image shifted over first vectors and second positions in said second image shifted over second vectors.

419. On information and belief, one or more of the Amazon ‘944 Products perform a method that includes deriving first and second vectors from sub-pixel accurate motion vectors by multiplying the vector components of the sub-pixel accurate motion vectors by a fraction to obtain fractional vector components.

420. On information and belief, one or more of the Amazon ‘944 Products perform a method that includes deriving first and second vectors from sub-pixel accurate motion vectors by rounding the fractional vector components to obtain vector components of the first vectors, which have only integer vector components.

421. On information and belief, one or more of the Amazon ‘944 Products perform a method that includes deriving first and second vectors from sub-pixel accurate motion vectors by subtracting the first vector from the candidate vector to obtain the second vector, whereby the

second vectors have vector components that, depending on the candidate vector and the fraction, may have non-integer values.

422. On information and belief, the Amazon '944 Products are available to businesses and individuals throughout the United States.

423. On information and belief, the Amazon '944 Products are provided to businesses and individuals located in the Eastern District of Texas.

424. By making, using, testing, offering for sale, and/or selling products and services for sub-pixel accurate motion vector estimation and motion-compensated interpolation or prediction, including but not limited to the Amazon '944 Products, Amazon has injured Dynamic Data and is liable to the Plaintiff for directly infringing one or more claims of the '944 patent, including at least claim 2 pursuant to 35 U.S.C. § 271(a).

425. On information and belief, Amazon also indirectly infringes the '944 patent by actively inducing infringement under 35 U.S.C. § 271(b).

426. Amazon has had knowledge of the '944 patent since at least service of this First Amended Complaint or shortly thereafter, and on information and belief, Amazon knew of the '944 patent and knew of its infringement, including by way of this lawsuit.

427. On information and belief, Amazon intended to induce patent infringement by third-party customers and users of the Amazon '944 Products and had knowledge that the inducing acts would cause infringement or was willfully blind to the possibility that its inducing acts would cause infringement. Amazon specifically intended and was aware that the normal and customary use of the accused products would infringe the '944 patent. Amazon performed the acts that constitute induced infringement, and would induce actual infringement, with knowledge of the '944 patent and with the knowledge that the induced acts would constitute infringement. For

example, Amazon provides the Amazon '944 Products that have the capability of operating in a manner that infringe one or more of the claims of the '944 patent, including at least claim 2, and Amazon further provides documentation and training materials that cause customers and end users of the Amazon '944 Products to utilize the products in a manner that directly infringe one or more claims of the '944 patent.<sup>34</sup> By providing instruction and training to customers and end-users on how to use the Amazon '944 Products in a manner that directly infringes one or more claims of the '944 patent, including at least claim 2, Amazon specifically intended to induce infringement of the '944 patent. On information and belief, Amazon engaged in such inducement to promote the sales of the Amazon '944 Products, e.g., through Amazon user manuals, product support, marketing materials, and training materials to actively induce the users of the accused products to infringe the '944 patent. Accordingly, Amazon has induced and continues to induce users of the accused products to use the accused products in their ordinary and customary way to infringe the '944 patent, knowing that such use constitutes infringement of the '944 patent.

428. The '944 patent is well-known within the industry as demonstrated by multiple citations to the '944 patent in published patents and patent applications assigned to technology companies and academic institutions. Amazon is utilizing the technology claimed in the '944 patent without paying a reasonable royalty. Amazon is infringing the '944 patent in a manner best

---

<sup>34</sup> See, e.g., *Amazon Elastic Transcoder*, DEVELOPER GUIDE API VERSION 2012-09-25 (Nov. 17, 2016); *Amazon Web Services*, GENERAL REFERENCE VERSION 1.0 (2018); Lee Atkinson, *Delivering Media & Entertainment using the AWS Cloud*, AWS TRANSFORMATION DAY GERMANY PRESENTATION (Oct. 25, 2017); *Fire TV Stick*, AMAZON USER GUIDE; *Watching Video in 4K Ultra HD on Fire TV*, AMAZON HELP WEBSITE, available at: <https://www.amazon.com/gp/help/customer/display.html?nodeId=201859000> (last visited Nov. 2018); *Amazon Fire TV*, AMAZON USER GUIDE; *Amazon Fire Tablet and Kindle E-Reader Quick Setup Guide*, AMAZON USER GUIDE (2014); *Fire & Kindle User's Guides*, Amazon Help Website, available at: <https://www.amazon.com/gp/help/customer/display.html?nodeId=200317150> (last visited Nov. 2018).

described as willful, wanton, malicious, in bad faith, deliberate, consciously wrongful, flagrant, or characteristic of a pirate.

429. To the extent applicable, the requirements of 35 U.S.C. § 287(a) have been met with respect to the '944 patent. As a result of Amazon's infringement of the '944 patent, Dynamic Data has suffered monetary damages, and seeks recovery in an amount adequate to compensate for Amazon's infringement, but in no event less than a reasonable royalty for the use made of the invention by Amazon together with interest and costs as fixed by the Court.

**COUNT XI**  
**INFRINGEMENT OF U.S. PATENT NO. 6,782,054**

430. Dynamic Data references and incorporates by reference the preceding paragraphs of this Complaint as if fully set forth herein.

431. Amazon designs, makes, uses, sells, and/or offers for sale in the United States products and/or services for motion estimation in a sequence of moving video pictures.

432. Amazon designs, makes, sells, offers to sell, imports, and/or uses Amazon products that comply with the H.265 standard. By way of example, the following Amazon Products perform encoding pursuant to the H.265 standard: the Amazon Web Services platform (e.g., AWS Elemental MediaConvert, AWS Elemental MediaLive, Amazon EC2 Accelerated Compute (EC2 G3 Instances), Amazon CloudFront); Amazon Fire TV products (e.g., Fire TV Stick 4k, Fire TV Cube, Fire TV (Gen 3)) (collectively, the "Amazon '054B Product(s)").

433. The accused Amazon Web Services platform products (e.g., AWS Elemental MediaConvert, AWS Elemental MediaLive, Amazon EC2 Accelerated Compute (EC2 G3 Instances), Amazon CloudFront) comply with the HEVC image processing standard. As shown

in the following excerpts from Amazon documentation the accused Amazon Web Services Platform products comply with the HEVC standard.

Until recently, H.264 (also known as AVC) was the best codec for optimizing quality and reducing file sizes; many content publishers still use it today. But it's quickly giving way to HEVC: High-Efficiency Video Coding. It's also referred to as H.265; different standards groups employ different designations to refer to the same standard. HEVC requires more computing power than H.264, but it's more efficient. Because AWS Elemental writes all of its encoding software from scratch, rather than relying on off-the-shelf encoding software, it is able to take the efficiency gains in each new generation of codec and adjust the software accordingly to get the best quality and/ or smallest video file sizes, along with the shortest encoding times.

Alicia Hunt, *A Video Compression Primer*, AWS MEDIA BLOG (January 30, 2019), available at: <https://aws.amazon.com/blogs/media/a-video-compression-primer/> (emphasis added).

Example 1	Example 2
<p>The per hour cost for a live channel with two HD inputs (using input switching) and producing 5 outputs with advanced audio in the US East (N. Virginia) Region:</p>	
<p><b>Input</b></p>	
<p>1080p HD, HEVC, 20Mbps = \$0.600 per hour</p>	
<p>1080p HD, HEVC, 20Mbps = \$0.600 per hour</p>	

*AWS Elemental MediaLive Pricing*, AWS DOCUMENTATION, available at: <https://aws.amazon.com/medialive/pricing/>

**Comprehensive Input and Output Support**  
 Create streams using standard video formats

AWS Elemental MediaConvert supports a broad range of video input and output formats, including those for broadcast as well as formats for delivery over the internet. The service supports the MPEG-2, AVC, Apple ProRes, and HEVC compression standards—including support for advanced color sampling (10-bit 4:2:2). It supports a broad range of adaptive bitrate packaging formats including CMAF, Apple HLS, DASH ISO, and Microsoft Smooth Streaming. AWS Elemental MediaConvert also supports processing and conversion of 4K resolution and high dynamic range (HDR) video content.

*AWS Elemental MediaConvert*, AWS DOCUMENTATION, available at: <https://aws.amazon.com/mediaconvert/features/> (AWS Elemental MediaConvert supports a broad range of video input and output formats . . . [t]he service supports . . . HEVC compression standards.”).



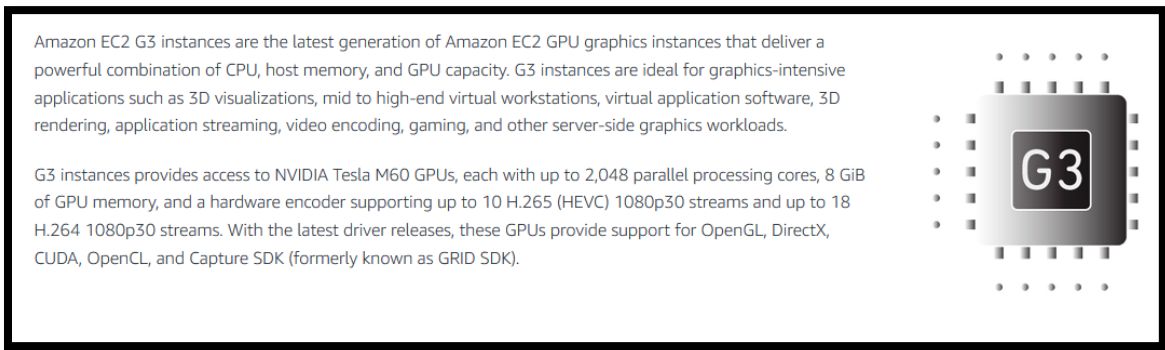

*Amazon EC2 G3 Instances, AWS DOCUMENTATION, available at: <https://aws.amazon.com/ec2/instance-types/g3/> (“G3 instances provides access to NVIDIA Tesla M60 GPUs, each with up to 2,048 parallel processing cores, 8 GiB of GPU memory, and a hardware encoder supporting up to 10 H.265 (HEVC) 1080p30 streams and up to 18 H.264 1080p30 streams.”).*

434. The accused Amazon Fire TV Products (e.g., Fire TV Stick 4k, Fire TV Cube, and Fire TV (Gen 3)) comply with the HEVC image processing standard. The below excerpt from Amazon Fire TV Developer documentation describes the accused Amazon Fire TV Products as complying with the requirements of the HEVC standard.

Fire TV Stick 4K			
Type	Codec	MIME type	Details
Video	H.265 (HEVC) (High Efficiency Video Coding)	video/hevc	Hardware accelerated up to 3840x2160p (4K) @ 60fps, 35 Mbps, Main 10 Profile Level 5.1, Color space 8-bit and 10-bit input with HDR10, HDR10+, HLG, and Dolby Vision support in rendering pipelines.

*Device Specifications for Fire TV, AMAZON DEVELOPER DOCUMENTATION, available at: <https://developer.amazon.com/docs/fire-tv/device-specifications.html> (describing the HEVC encoding and decoding support for the Amazon Fire TV Products).*

435. On information and belief, one or more Amazon subsidiaries and/or affiliates use the Amazon ‘054B Products in regular business operations.

436. On information and belief, one or more of the Amazon ‘054B Products include technology for motion estimation in a sequence of moving video pictures. In addition, the Amazon ‘054B Products perform H.265 video encoding using a motion estimator. “Furthermore, the

encoder needs to perform motion estimation, which is one of the most computationally expensive operations in the encoder, and complexity is reduced by allowing a small number of candidates.”

Gary J. Sullivan, Jens-Rainer Ohm, Woo-Jin Han, and Thomas Wiegand, *Overview of the High Efficiency Video Coding (HEVC) Standard*, published in IEEE TRANSACTIONS ON CIRCUITS AND SYSTEMS FOR VIDEO TECHNOLOGY, VOL. 22, NO. 12 at 1661 (December 2012).

437. On information and belief, Amazon has directly infringed and continues to directly infringe the ‘054B patent by, among other things, making, using, offering for sale, and/or selling technology for motion estimation in a sequence of moving video pictures, including but not limited to the Amazon ‘054B Products.

438. The Amazon ‘054B Products obtain two or more candidate motion vectors from the motion estimator. The candidate motion vectors are associated with a video region. Specifically, the motion estimator generates a set of candidate motion vectors for a grouping of pixels (prediction unit). The Amazon ‘054B Products generate a set of candidate motion vectors for the group of pixels. The group of pixels that are associated with the motion vector are referred to as a prediction unit and comprise a video region. The below excerpt from documentation regarding the HEVC Encoding process describes that “Motion vectors of the current block are usually correlated with the motion vectors of neighboring blocks in the current picture or in the earlier coded pictures.”

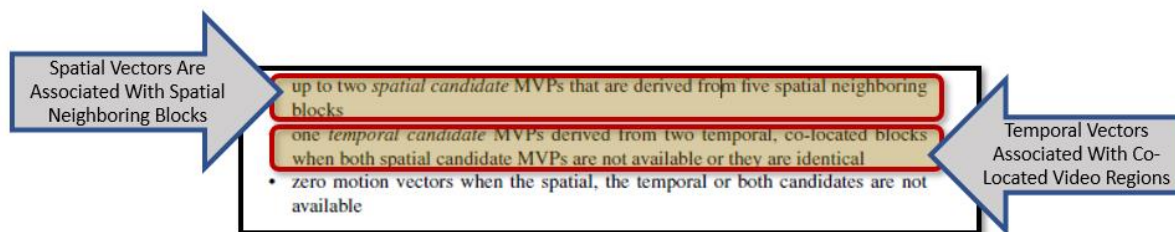

Benjamin Bross et al, *Inter-Picture Prediction in HEVC*, HIGH EFFICIENCY VIDEO CODING (HEVC) at 116 (September 2014).

439. The advanced motion vector prediction technologies in the Amazon ‘054B Products perform the steps of motion vector estimation. Specifically, the Amazon ‘054B Products receive video content and as part of the encoding process divide the video content into coding blocks (aka coding units). The Amazon ‘054B Products further encode video by creating prediction units (PU) that are a basic unit for prediction. The Amazon ‘054B Products generate two predictor candidate motion vectors (a spatial motion vector and temporal motion vector). The first predictor candidate motion vector is drawn from a list of spatial motion vector candidates. In AMVP, the motion vector selection process is composed by two steps wherein the candidate motion vectors are constructed into an index and then the motion vectors are compared. “In AMVP, the motion vector selection process is composed by two steps in encoder implementation. The first step is the motion vector candidate set construction process and the second step is the best motion vector selection step. In the first step, the motion vector candidate set is organized by selecting the motion vectors spatially and temporally.” Gwo-Long Li, Chuen-Ching Wang, and Kuang-Hung Chiang, *An Efficient Motion Vector Prediction Method For Avoiding AMVP Data Dependency For HEVC*, 2014 IEEE INTERNATIONAL CONFERENCE ON ACOUSTIC, SPEECH AND SIGNAL PROCESSING (ICASSP) at 7412-13 (2014) (emphasis added).

440. The candidate motion vectors are extracted from a set of previous motion vectors and are associated with a video region by the Amazon ‘054B Products. Specifically, the Amazon ‘054B Products use a translational motion model wherein the position of the block in a previously decoded picture is indicated by a motion vector:  $\Delta x$ ;  $\Delta y$  where  $\Delta x$  specifies the horizontal and  $\Delta y$  the vertical displacement relative to the position of the current block. The motion vectors:  $\Delta x$ ;  $\Delta y$  are of fractional sample accuracy to more accurately capture the movement of the underlying object. Interpolation is applied on the reference pictures to derive the prediction signal when the

corresponding motion vector has fractional sample accuracy. The previously decoded picture is referred to as the reference picture and indicated by a reference index  $\Delta t$  to a reference picture list.

441. The following block diagram illustrates the motion vector selection process in the Amazon '054B Products. Specifically, the encoded video data received by the Amazon '054B Products is encoded using inter-picture prediction where the motion data of a block is correlated with neighboring blocks. Further, the Amazon '054B Products receive data that is encoded using advanced motion vector prediction where the best predictor for each motion block is based on applying a penalty value (also referred to as a cost) to each candidate motion vector.

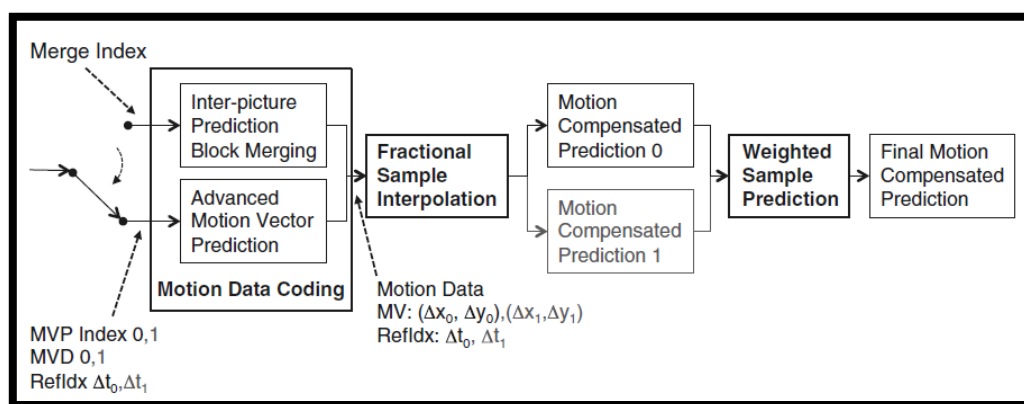

Benjamin Bross et al, *Inter-Picture Prediction in HEVC*, HIGH EFFICIENCY VIDEO CODING (HEVC) at 116 (September 2014).

442. On information and belief, any implementation of the HEVC standard would infringe the '054B patent as every possible implementation of the standard requires: selecting a displacement vector as a best motion vector for a region in a field from a plurality of at least two candidate motion vectors by applying an error function to each of said plural candidate motion vectors, wherein the candidate motion vector with the least error is selected as the displacement vector for the region in the field; wherein said error function comprises a first penalty term that depends on a type of said candidate motion vector and a second penalty term that depends on the position and size of said candidate motion vector.

443. The Amazon ‘054B Products carry out a block-based motion vector estimation process that involves comparing a plurality of candidate vectors to determine block-based motion vectors. The Amazon ‘054B Products generate two predictor candidate motion vectors (a spatial motion vector and temporal motion vector). The first predictor candidate motion vector is drawn from a list of spatial motion vector candidates.

three spatially neighboring MVs. HEVC improves the MV prediction by applying an MV prediction competition as initially proposed in [18]. In HEVC, this competition was further adapted to large block sizes with so-called *advanced motion vector prediction* (AMVP) in [19]. In the DIS Main profile, AMVP has two predictor candidates competing for the prediction. Two spatial motion vector predictor (MVP) candidates are considered and, when at least one of them is not available or they are redundant, a temporal motion vector prediction (TMVP) candidate is considered. The candidates

Philipp Helle et al, *Block Merging for Quadtree-Based Partitioning in HEVC*, *IEEE TRANS. CIR. AND SYS. FOR VIDEO TECHNOLOGY*, Vol. 22 No. 12 at 1723 (December 2012) (“AMVP has two predictor candidates competing for the prediction. Two spatial motion vector predictor (MVP) candidates are considered and, when at least one of them is not available or they are redundant, a temporal motion vector prediction (TMVP) candidate is considered.”).

444. The Amazon ‘054B Products apply a cost function (also referred to as an error function and/or penalty). Specifically, the Amazon ‘054B Products apply a rate distortion cost calculation to the two or more candidate motion vectors to select the most suitable candidate in advanced motion vector prediction. The cost function / penalty applied to the candidate motion vectors is based on the type of motion vector and a second penalty based on both the size of the candidate motion vector and the spatial position of the video region within the video image.

445. The following block diagram shows (1) the “RD Cost Equation” which is the error function and (2) the use of the error function to create a “Final Candidate MV.” Further, as shown below the motion vectors that is used always contains at least two motion vectors and can be

comprised of spatial and temporal candidate motion vectors. The prior pruning of temporal candidates or spatial candidates acts as a first penalty function based on the type of motion vector.

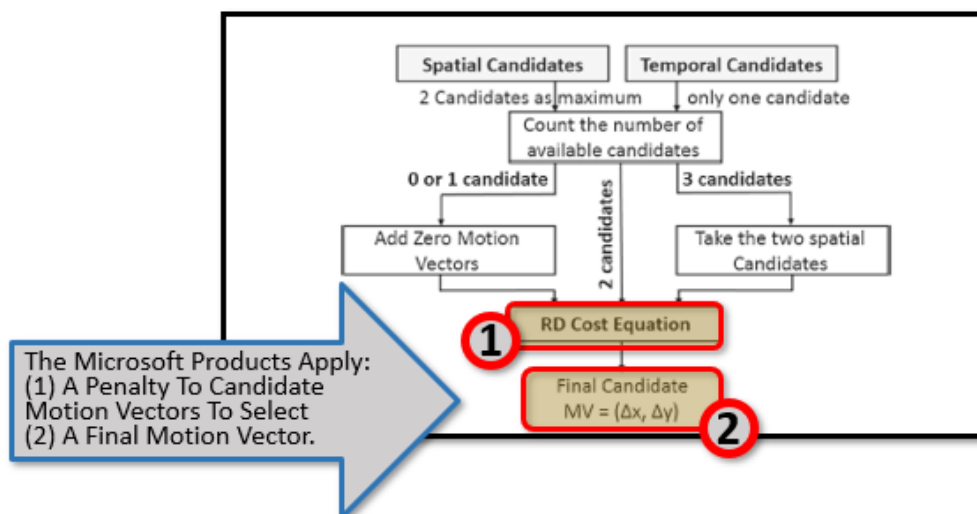

Ahmed M. Abdelsalam, Ahmed Shalaby, Mohammed S. Sayed, *Towards An FPGA-Based HEVC Encoder: A Low Complexity Rate Distortion Scheme For AMVP*, CIRCUITS SYST. SIGNAL PROCESS at 7 (February 10, 2017) (annotations added).

446. Amazon’s ‘054B Products use a rate distortion cost (“RD Cost Equation”) that selects the best motion vector based on the size of the motion vector and the spatial position of the motion vector. The formula is selected based on the following equation:

$$J_{\text{cost}} = \arg \min_{m \in \{1,2\}} D(m) + \lambda \cdot R(m)$$

447. The Amazon ‘054B Products apply a second penalty based on the RD Cost Equation wherein  $J_{\text{cost}}$  “is the best rate distortion cost among the final two motion vector candidates.” Ahmed M. Abdelsalam, Ahmed Shalaby, Mohammed S. Sayed, *Towards An FPGA-Based HEVC Encoder: A Low Complexity Rate Distortion Scheme For AMVP*, CIRCUITS SYST. SIGNAL PROCESS at 7 (February 10, 2017). The two primary factors that are used in calculating the rate distortion cost take into account the size of the motion vectors and the spatial position of the motion vectors.

448. The Amazon ‘054B Products, in calculating the penalty value care the size of the motion vectors. “Rate term  $R(m)$  represents an estimated number of required bits to transmit the motion parameters.” *Id.*

449. The Amazon ‘054B Products, in calculating the penalty value, depend on the spatial position of the motion vectors to compare the motion vectors using the distortion  $D(m)$ . The distortion  $D(m)$  is measured as the sum of absolute difference (SAD) value between (1) the current prediction block and (2) the candidate prediction block indicated by index  $m$ ,

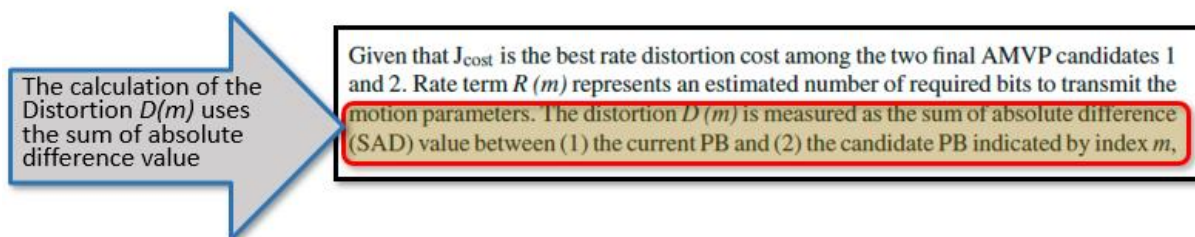

Ahmed M. Abdelsalam, Ahmed Shalaby, Mohammed S. Sayed, *Towards An FPGA-Based HEVC Encoder: A Low Complexity Rate Distortion Scheme For AMVP*, CIRCUITS SYST. SIGNAL PROCESS at 7 (February 10, 2017) (annotations added).

450. On information and belief, by complying with the HEVC standard, the Amazon devices – such as the Amazon ‘054B Products – necessarily infringe the ‘054B patent. Mandatory sections of the HEVC standard require the elements required by certain claims of the ‘054B patent, including but not limited to claim 13. *High Efficiency Video Coding*, SERIES H: AUDIOVISUAL AND MULTIMEDIA SYSTEMS: INFRASTRUCTURE OF AUDIOVISUAL SERVICES – CODING OF MOVING VIDEO REC. ITU-T H.265 (February 2018). The following sections of the HEVC Standard are relevant to AMAZON’s infringement of the ‘054B patent: “3.110 Prediction Unit Definition;” “6.3.2 Block and quadtree structures;” “6.3.3 Spatial or component-wise partitioning;” “6.4.2 Derivation process for prediction block availability;” “7.3.8.5 Coding unit syntax;” “7.3.8.6 Prediction unit syntax;” “8.3.2 Decoding process for reference picture set;” “8.5.4 Decoding process for the residual signal of coding units coded in inter prediction mode;” “8.6 Scaling, transformation and



array construction process prior to deblocking filter process;” “8.5.2 Inter prediction process;” “8.5.3 Decoding process for prediction units in inter prediction mode;” and “8.7.2 Deblocking filter process.”

451. The Amazon ‘054B Products calculate the penalty based in part on the sum of absolute difference distortion value calculated by comparing the block where the candidate motion vector is located against the location of the reference candidate prediction block. The formula for the calculation of the sum of absolute difference distortion value is shown in the following excerpt relating to the HEVC encoding used by the Amazon ‘054B products.

and  $\lambda$  represents the Lagrangian multiplier. The SAD distortion  $D(m)$  value between a candidate block and current block of size  $M \times N$  pixels can be calculated according to:

$$\sum_{i=1}^M \sum_{j=1}^N |CPB(i, j) - RPB(i, j)| \quad (2)$$

where CPB represents the current prediction block pixels and RPB represents the reference candidate prediction block pixels.

Comparing Location Of (1) Candidate Vector And (2) Refence Vector

Ahmed M. Abdelsalam, Ahmed Shalaby, Mohammed S. Sayed, *Towards An FPGA-Based HEVC Encoder: A Low Complexity Rate Distortion Scheme For AMVP*, CIRCUITS SYST. SIGNAL PROCESS at 7 (February 10, 2017) (annotations added).

452. On information and belief, one or more of the Amazon ‘054B Products increase the speed of convergence of motion vectors to improve the convergence process.

453. On information and belief, one or more of the Amazon ‘054B Products perform a method to enhance motion estimation that includes selecting a displacement vector as a best motion vector for a region in a field from a plurality of at least two candidate motion vectors by applying an error function to each of said plural candidate motion vectors, wherein the candidate motion vector with the least error is selected as the displacement vector for the region in the field.



454. On information and belief, one or more of the Amazon '054B Products perform a method to enhance motion estimation that includes an error function comprising a first penalty term that depends on a type of the candidate motion vector and a second penalty term that depends on the position and size of the candidate motion vector.

455. On information and belief, the Amazon '054B Products are available to businesses and individuals throughout the United States.

456. On information and belief, the Amazon '054B Products are provided to businesses and individuals located in the Eastern District of Texas.

457. By making, using, testing, offering for sale, and/or selling products and services for motion estimation in a sequence of moving video pictures, including but not limited to the Amazon '054B Products, Amazon has injured Dynamic Data and is liable to the Plaintiff for directly infringing one or more claims of the '054B patent, including at least claim 13 pursuant to 35 U.S.C. § 271(a).

458. On information and belief, Amazon also indirectly infringes the '054B patent by actively inducing infringement under 35 U.S.C. § 271(b).

459. Amazon has had knowledge of the '054B patent since at least service of this First Amended Complaint or shortly thereafter, and on information and belief, Amazon knew of the '054B patent and knew of its infringement, including by way of this lawsuit.

460. On information and belief, Amazon intended to induce patent infringement by third-party customers and users of the Amazon '054B Products and had knowledge that the inducing acts would cause infringement or was willfully blind to the possibility that its inducing acts would cause infringement. Amazon specifically intended and was aware that the normal and customary use of the accused products would infringe the '054B patent. Amazon performed the

acts that constitute induced infringement, and would induce actual infringement, with knowledge of the '054B patent and with the knowledge that the induced acts would constitute infringement. For example, Amazon provides the Amazon '054B Products that have the capability of operating in a manner that infringe one or more of the claims of the '054B patent, including at least claim 13, and Amazon further provides documentation and training materials that cause customers and end users of the Amazon '054B Products to utilize the products in a manner that directly infringe one or more claims of the '054B patent.<sup>35</sup> By providing instruction and training to customers and end-users on how to use the Amazon '054B Products in a manner that directly infringes one or more claims of the '054B patent, including at least claim 13, Amazon specifically intended to induce infringement of the '054B patent. On information and belief, Amazon engaged in such inducement to promote the sales of the Amazon '054B Products, e.g., through Amazon user manuals, product support, marketing materials, and training materials to actively induce the users of the accused products to infringe the '054B patent. Accordingly, Amazon has induced and continues to induce users of the accused products to use the accused products in their ordinary and customary way to infringe the '054B patent, knowing that such use constitutes infringement of the '054B patent.

461. The '054B patent is well-known within the industry as demonstrated by multiple citations to the '054B patent in published patents and patent applications assigned to technology companies and academic institutions. Amazon is utilizing the technology claimed in the '054B

---

<sup>35</sup> See, e.g., *Amazon Elastic Transcoder*, DEVELOPER GUIDE API VERSION 2012-09-25 (Nov. 17, 2016); *Amazon Web Services*, GENERAL REFERENCE VERSION 1.0 (2018); Lee Atkinson, *Delivering Media & Entertainment using the AWS Cloud*, AWS TRANSFORMATION DAY GERMANY PRESENTATION (Oct. 25, 2017); *Fire TV Stick*, AMAZON USER GUIDE; *Watching Video in 4K Ultra HD on Fire TV*, AMAZON HELP WEBSITE, available at: <https://www.amazon.com/gp/help/customer/display.html?nodeId=201859000> (last visited Nov. 2018); *Amazon Fire TV*, AMAZON USER GUIDE.

patent without paying a reasonable royalty. Amazon is infringing the '054B patent in a manner best described as willful, wanton, malicious, in bad faith, deliberate, consciously wrongful, flagrant, or characteristic of a pirate.

462. To the extent applicable, the requirements of 35 U.S.C. § 287(a) have been met with respect to the '054B patent.

463. As a result of Amazon's infringement of the '054B patent, Dynamic Data has suffered monetary damages, and seeks recovery in an amount adequate to compensate for Amazon's infringement, but in no event less than a reasonable royalty for the use made of the invention by Amazon together with interest and costs as fixed by the Court.

**COUNT XII**  
**INFRINGEMENT OF U.S. PATENT NO. 7,010,039**

464. Dynamic Data references and incorporates by reference the preceding paragraphs of this Complaint as if fully set forth herein.

465. Amazon designs, makes, uses, sells, and/or offers for sale in the United States products and/or services for detecting motion.

466. Amazon designs, makes, sells, offers to sell, imports, and/or uses Amazon products that comply with the H.265 standard. By way of example, the following Amazon Products perform encoding pursuant to the H.265 standard: the Amazon Web Services platform (e.g., AWS Elemental MediaConvert, AWS Elemental MediaLive, Amazon EC2 Accelerated Compute (EC2 G3 Instances), Amazon CloudFront); Amazon Fire TV products (e.g., Fire TV Stick 4k, Fire TV Cube, Fire TV (Gen 3)) (collectively, the "Amazon '039 Product(s)").

467. The accused Amazon Web Services platform products (e.g., AWS Elemental MediaConvert, AWS Elemental MediaLive, Amazon EC2 Accelerated Compute (EC2 G3

Instances), Amazon CloudFront) comply with the HEVC image processing standard. As shown in the following excerpts from Amazon documentation the accused Amazon Web Services Platform products comply with the HEVC standard.

Until recently, H.264 (also known as AVC) was the best codec for optimizing quality and reducing file sizes; many content publishers still use it today. But it's quickly giving way to HEVC: High-Efficiency Video Coding. It's also referred to as H.265; different standards groups employ different designations to refer to the same standard. HEVC requires more computing power than H.264, but it's more efficient. Because AWS Elemental writes all of its encoding software from scratch, rather than relying on off-the-shelf encoding software, it is able to take the efficiency gains in each new generation of codec and adjust the software accordingly to get the best quality and/ or smallest video file sizes, along with the shortest encoding times.

Alicia Hunt, *A Video Compression Primer*, AWS MEDIA BLOG (January 30, 2019), available at: <https://aws.amazon.com/blogs/media/a-video-compression-primer/> (emphasis added).

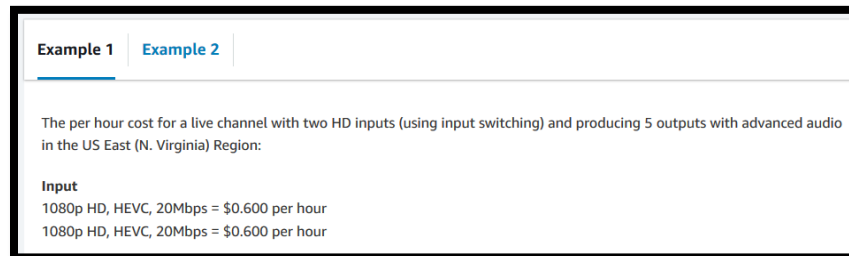

*AWS Elemental MediaLive Pricing*, AWS DOCUMENTATION, available at: <https://aws.amazon.com/medialive/pricing/>

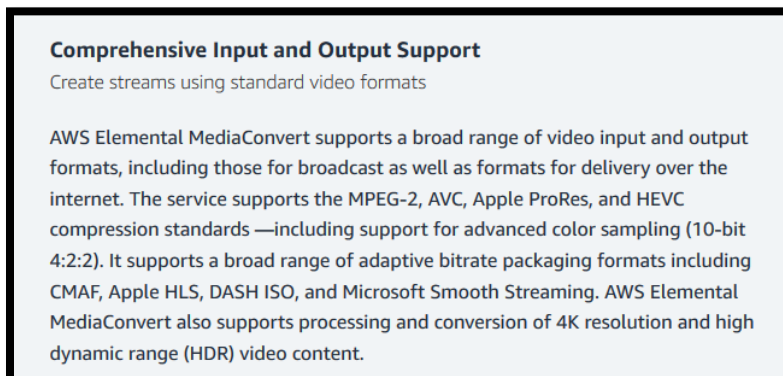

*AWS Elemental MediaConvert*, AWS DOCUMENTATION, available at: <https://aws.amazon.com/mediaconvert/features/> (AWS Elemental MediaConvert supports a broad range of video input and output formats . . . [t]he service supports . . . HEVC compression standards.”).

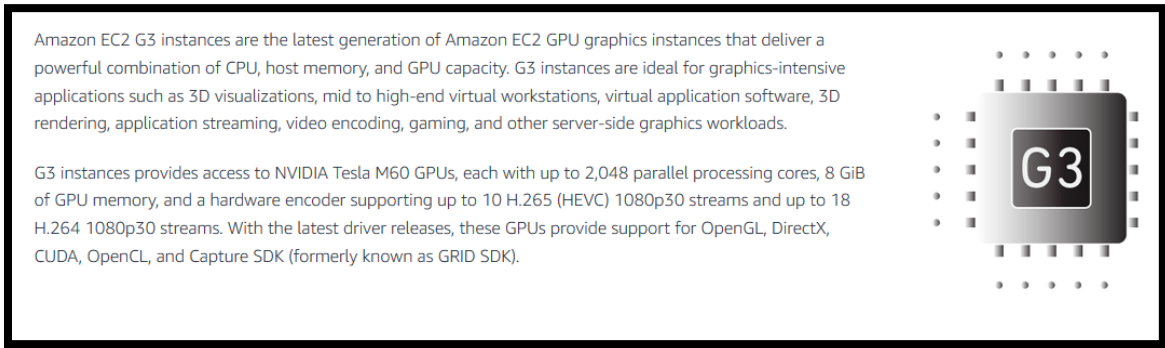

*Amazon EC2 G3 Instances, AWS DOCUMENTATION, available at: <https://aws.amazon.com/ec2/instance-types/g3/> (“G3 instances provides access to NVIDIA Tesla M60 GPUs, each with up to 2,048 parallel processing cores, 8 GiB of GPU memory, and a hardware encoder supporting up to 10 H.265 (HEVC) 1080p30 streams and up to 18 H.264 1080p30 streams.”).*

468. The accused Amazon Fire TV Products (e.g., Fire TV Stick 4k, Fire TV Cube, and Fire TV (Gen 3)) comply with the HEVC image processing standard. The below excerpt from Amazon Fire TV Developer documentation describes the accused Amazon Fire TV Products as complying with the requirements of the HEVC standard.

Fire TV Stick 4K			
Type	Codec	MIME type	Details
Video	H.265 (HEVC) (High Efficiency Video Coding)	video/hevc	Hardware accelerated up to 3840x2160p (4K) @ 60fps, 35 Mbps, Main 10 Profile Level 5.1, Color space 8-bit and 10-bit input with HDR10, HDR10+, HLG, and Dolby Vision support in rendering pipelines.

*Device Specifications for Fire TV, AMAZON DEVELOPER DOCUMENTATION, available at: <https://developer.amazon.com/docs/fire-tv/device-specifications.html> (describing the HEVC encoding and decoding support for the Amazon Fire TV Products).*

469. On information and belief, the Amazon ‘039 Products contain functionality wherein a criterion function for candidate vectors is optimized. The criterion function depends on data obtained from the previous and next images in the video data stream. The optimizing is carried out at a temporal intermediate position in non-covered and covered areas. The following

excerpts explain how HEVC is a form of encoding video information using a temporal intermediate position between previous and next images.

One way of achieving high video compression is to predict pixel values for a frame based on prior and succeeding pictures in the video. Like its predecessors, H.265 features the ability to predict pixel values between pictures, and in particular, to specify in which order pictures are coded and which pictures are predicted from which. The coding order is specified for Groups Of Pictures (GOP), where a number of pictures are grouped together and predicted from each other in a specified order. The pictures available to predict from, called reference pictures, are specified for every individual picture.

Johan Bartelmess. Compression Efficiency of Different Picture Coding Structures in High Efficiency Video Coding (HEVC), UPTec STS 16006 at 4 (March 2016)

HEVC features both low- and high-level methods for dependency removal which can be used to leverage multi-core processors [13]. Only the three high-level mechanisms slices, tiles and WPP are of interest for this work. It is important to note that all of them subdivide individual video frames based on CTUs which are HEVC's basic processing unit. CTUs have a maximum size of  $64 \times 64$  luma pixels and are recursively split into square-shaped Coding Units (CUs), which contain Prediction Units (PUs) and Transform Units (TUs) [14].

Stefan Radicke, *et al.*, *Many-Core HEVC Encoding Based on Wavefront Parallel Processing and GPU-accelerated Motion Estimation*, E-BUSINESS AND TELECOMMUNICATIONS: 11TH INTERNATIONAL JOINT CONFERENCE at 296 (2015) (“HEVC feature both low- and high-level methods for dependency removal which can be used to leverage multi-core processors. . . It is important to note that all of them subdivide individual video frames based on CTUs which are HEVC' basic processing unit.”).

470. On information and belief, the Amazon '039 Products receive encoded video data that is encoded using inter-frame coding. The encoded video stream received by the Amazon Products are coded using its predecessor frame and subsequent frame. Inter-prediction used in the encoded video data received by the Amazon Products allows a transform block to span across multiple prediction blocks for inter-picture predicted coding units to maximize the potential coding efficiency benefits of the quadtree-structured transform block partitioning.

The basic source-coding algorithm is a hybrid of interpicture prediction to exploit *temporal statistical dependences*, intrapicture prediction to exploit spatial statistical dependences, and transform

coding of the prediction residual signals to further exploit spatial statistical dependences.

G. J. Sullivan, J.-R. Ohm, W.-J. Han, and T. Wiegand, *Overview of the High Efficiency Video Coding (HEVC) standard*, IEEE TRANS. CIRCUITS SYST. VIDEO TECHNOL., vol. 22, no. 12, p. 1654 (December 2012) (emphasis added).

471. The encoded video stream received by the Amazon Products are encoded using inter-picture prediction that makes use of the temporal correlation between pictures to derive a motion-compensated prediction (MCP) for a block of image samples. For this block-based motion compensated prediction, a video picture is divided into rectangular blocks. Assuming homogeneous motion inside one block, and that moving objects are larger than one block, for each block, a corresponding block in a previously decoded picture can be found that serves as a predictor. The general concept of inter-frame-based encoding using motion-compensated prediction based on a translational motion model is illustrated below.

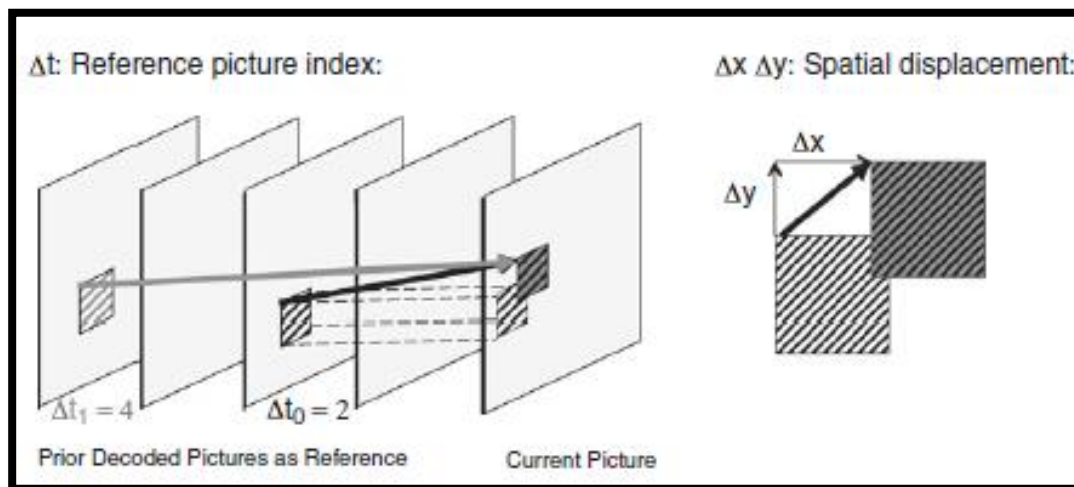

Benjamin Bross, *Inter-Picture Prediction In HEVC*, HIGH EFFICIENCY VIDEO CODING (HEVC) at 114 (September 2014).

472. On information and belief, the following excerpt from an article describing the architecture of the encoded video stream received by the Amazon '039 Products describes the functionality wherein the second encoded frame of the video data is dependent on the encoding of

a first frame. “HEVC inter prediction uses motion vectors pointing to one reference frame . . . or two reference frames (bi-prediction) to predict a block of pixels.”

HEVC inter prediction uses motion vectors pointing to one reference frame (uni-prediction) or two reference frames (bi-prediction) to predict a block of pixels. The size of the predicted block, called Prediction Unit (PU), is determined by the Coding Unit (CU) size and its partitioning mode. For example, a 32x32 CU with 2NxN partitioning is split into two PUs of size 32x16, or a 16x16 CU with nLx2N partitioning is split into 4x16 and 12x16 PUs.

Mehul Tikekar, *et al.*, *Decoder Hardware Architecture for HEVC*, HIGH EFFICIENCY VIDEO CODING (HEVC) (September 2014).

473. On information and belief, the following diagram shows how the Amazon ‘039 Products receive video data encoded using inter-frame prediction. Specifically, interframe prediction generates a motion vector based on the motion estimation across frames.

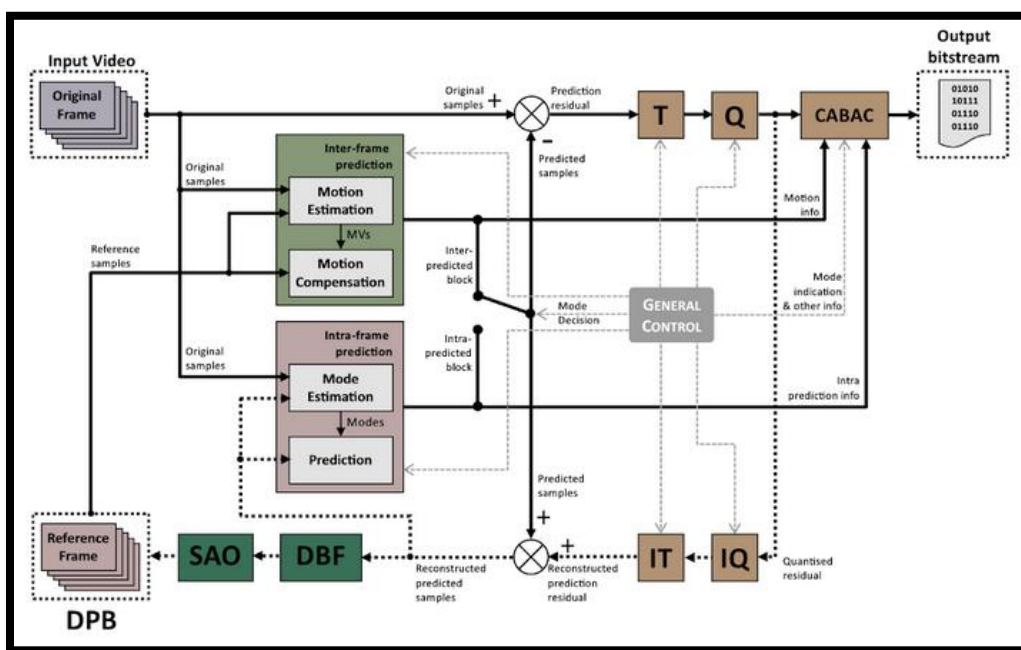

Guilherme Corrêa, *et al.*, COMPLEXITY-AWARE HIGH EFFICIENCY VIDEO CODING at 16 (2015).

474. On information and belief, the Amazon ‘039 Products receive encoded video data wherein the second frame includes a region encoding a motion vector difference in position between the region corresponding to the second frame indicating the first frame, the motion vector



defines a region between the frame and the second frame corresponding to the first region the correspondence relationship. Specifically, the encoded video data received by the Amazon Products use a translational motion model wherein the position of the block in a previously decoded picture is indicated by a motion vector:  $\Delta x$ ;  $\Delta y$  where  $\Delta x$  specifies the horizontal and  $\Delta y$  the vertical displacement relative to the position of the current block. The motion vectors:  $\Delta x$ ;  $\Delta y$  are of fractional sample accuracy to more accurately capture the movement of the underlying object. Interpolation is applied on the reference pictures to derive the prediction signal when the corresponding motion vector has fractional sample accuracy. The previously decoded picture is referred to as the reference picture and indicated by a reference index  $\Delta t$  to a reference picture list. These translational motion model parameters, *i.e.*, motion vectors and reference indices, are further referred to as motion data.

475. On information and belief, the “Overview of Design Characteristics” in the HEVC specification describes the use of “motion vectors for block-based inter prediction to exploit temporal statistical dependencies between frames.”

compression. Encoding algorithms (not specified in this Recommendation | International Standard) may select between inter and intra coding for block-shaped regions of each picture. Inter coding uses motion vectors for block-based inter prediction to exploit temporal statistical dependencies between different pictures. Intra coding uses various spatial prediction modes to exploit spatial statistical dependencies in the source signal for a single picture. Motion vectors and intra prediction modes may be specified for a variety of block sizes in the picture. The prediction residual may then be further compressed using a transform to remove spatial correlation inside the transform block before it is quantized, producing a possibly irreversible process that typically discards less important visual information while forming a close approximation to the source samples. Finally, the motion vectors or intra prediction modes may also be further compressed using a variety of prediction mechanisms, and, after prediction, are combined with the quantized transform coefficient information and encoded using arithmetic coding.

*High Efficiency Video Coding, Series H: Audiovisual And Multimedia Systems: Infrastructure Of Audiovisual Services – Coding Of Moving Video Rec. ITU-T H.265 at § 0.7 (April 2015) (annotation added).*

476. On information and belief, by complying with the HEVC standard, the AMAZON devices – such as the Amazon ‘039 Products – necessarily infringe the ‘039 patent. Mandatory sections of the HEVC standard require the elements required by certain claims of the ‘039 patent,

including but not limited to claim 13. *High Efficiency Video Coding*, SERIES H: AUDIOVISUAL AND Multimedia SYSTEMS: INFRASTRUCTURE OF AUDIOVISUAL SERVICES – CODING OF MOVING VIDEO REC. ITU-T H.265 (February 2018). The following sections of the HEVC Standard are relevant to Amazon’s infringement of the ‘039 patent: “5.3 Logical operators;” “5.10 Variables, syntax elements and tables;” “5.11 Text description of logical operations;” “7.2 Specification of syntax functions and descriptors;” “7.3.1 NAL unit syntax;” “7.3.2 Raw byte sequence payloads, trailing bits and byte alignment syntax;” “7.3.5 Supplemental enhancement information message syntax;” “7.4.2 NAL unit semantics;” and “7.4.6 Supplemental enhancement information message semantics.”

477. On information and belief, one or more Amazon subsidiaries and/or affiliates use the Amazon ‘039 Products in regular business operations.

478. On information and belief, the Amazon ‘039 Products are available to businesses and individuals throughout the United States.

479. On information and belief, the Amazon ‘039 Products are provided to businesses and individuals located in the Eastern District of Texas.

480. On information and belief, Amazon has directly infringed and continues to directly infringe the ‘039 patent by, among other things, making, using, offering for sale, and/or selling technology for detecting motion, including but not limited to the Amazon ‘039 Products.

481. By making, using, testing, offering for sale, and/or selling products and services, including but not limited to the Amazon ‘039 Products, Amazon has injured Dynamic Data and is liable for directly infringing one or more claims of the ‘039 patent, including at least claim 13, pursuant to 35 U.S.C. § 271(a).

482. On information and belief, Amazon also indirectly infringes the '039 patent by actively inducing infringement under 35 U.S.C. § 271(b).

483. On information and belief, Amazon has had knowledge of the '039 patent since at least service of this First Amended Complaint or shortly thereafter, and on information and belief, Amazon knew of the '039 patent and knew of its infringement, including by way of this lawsuit.

484. On information and belief, Amazon intended to induce patent infringement by third-party customers and users of the Amazon '039 Products and had knowledge that the inducing acts would cause infringement or was willfully blind to the possibility that its inducing acts would cause infringement. Amazon specifically intended and was aware that the normal and customary use of the accused products would infringe the '039 patent. Amazon performed the acts that constitute induced infringement, and would induce actual infringement, with knowledge of the '039 patent and with the knowledge that the induced acts would constitute infringement. For example, Amazon provides the Amazon '039 Products that have the capability of operating in a manner that infringe one or more of the claims of the '039 patent, including at least claim 13, and Amazon further provides documentation and training materials that cause customers and end users of the Amazon '039 Products to utilize the products in a manner that directly infringe one or more claims of the '039 patent.<sup>36</sup> By providing instruction and training to customers and end-users on how to use the Amazon '039 Products in a manner that directly infringes one or more claims of the '039 patent, including at least claim 13, Amazon specifically intended to induce infringement

---

<sup>36</sup> See, e.g., *Amazon Elastic Transcoder*, DEVELOPER GUIDE API VERSION 2012-09-25 (Nov. 17, 2016); *Amazon Web Services*, GENERAL REFERENCE VERSION 1.0 (2018); Lee Atkinson, *Delivering Media & Entertainment using the AWS Cloud*, AWS TRANSFORMATION DAY GERMANY PRESENTATION (Oct. 25, 2017); *Fire TV Stick*, AMAZON USER GUIDE; *Watching Video in 4K Ultra HD on Fire TV*, AMAZON HELP WEBSITE, available at: <https://www.amazon.com/gp/help/customer/display.html?nodeId=201859000> (last visited Nov. 2018); *Amazon Fire TV*, AMAZON USER GUIDE.

of the '039 patent. On information and belief, Amazon engaged in such inducement to promote the sales of the Amazon '039 Products, e.g., through Amazon user manuals, product support, marketing materials, and training materials to actively induce the users of the accused products to infringe the '039 patent. Accordingly, Amazon has induced and continues to induce users of the accused products to use the accused products in their ordinary and customary way to infringe the '039 patent, knowing that such use constitutes infringement of the '039 patent.

485. The '039 patent is well-known within the industry as demonstrated by multiple citations to the '039 patent in published patents and patent applications assigned to technology companies and academic institutions. Amazon is utilizing the technology claimed in the '039 patent without paying a reasonable royalty. Amazon is infringing the '039 patent in a manner best described as willful, wanton, malicious, in bad faith, deliberate, consciously wrongful, flagrant, or characteristic of a pirate.

486. To the extent applicable, the requirements of 35 U.S.C. § 287(a) have been met with respect to the '039 patent.

487. As a result of Amazon's infringement of the '039 patent, Dynamic Data has suffered monetary damages, and seeks recovery in an amount adequate to compensate for Amazon's infringement, but in no event less than a reasonable royalty for the use made of the invention by Amazon together with interest and costs as fixed by the Court.

**COUNT XIII**  
**INFRINGEMENT OF U.S. PATENT NO. 7,058,227**

488. Dynamic Data references and incorporates by reference the preceding paragraphs of this Complaint as if fully set forth herein.

489. Amazon designs, makes, uses, sells, and/or offers for sale in the United States products and/or services for detecting occlusion and reducing halo effects in motion compensated pictures.

490. Amazon designs, makes, sells, offers to sell, imports, and/or uses Amazon products that implement the VP9 compliant image processing functionality, including: the Amazon Web Services platform (e.g., AWS Elastic Transcoder) and Amazon Fire TVs (e.g., Fire TV Stick 4k) (collectively, the “Amazon ‘227 Product(s)’”).

491. On information and belief, one or more Amazon subsidiaries and/or affiliates use the Amazon ‘227 Products in regular business operations.

492. The accused Amazon ‘227 Products comply with the VP9 standard. The below excerpt from documentation regarding the AWS Elastic Transcoder shows that it supports transcoding into VP9 format content.

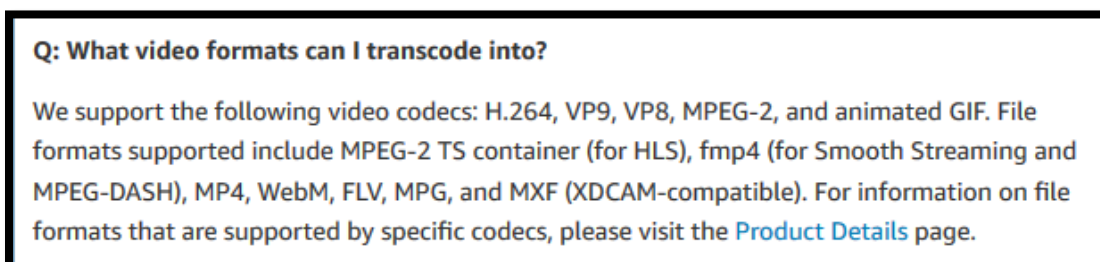
A screenshot of a FAQ entry from the AWS Elastic Transcoder documentation. The text is enclosed in a black rectangular border. The question is "Q: What video formats can I transcode into?". The answer states: "We support the following video codecs: H.264, VP9, VP8, MPEG-2, and animated GIF. File formats supported include MPEG-2 TS container (for HLS), fmp4 (for Smooth Streaming and MPEG-DASH), MP4, WebM, FLV, MPG, and MXF (XDCAM-compatible). For information on file formats that are supported by specific codecs, please visit the Product Details page." The words "Product Details" are a blue hyperlink.

**Q: What video formats can I transcode into?**

We support the following video codecs: H.264, VP9, VP8, MPEG-2, and animated GIF. File formats supported include MPEG-2 TS container (for HLS), fmp4 (for Smooth Streaming and MPEG-DASH), MP4, WebM, FLV, MPG, and MXF (XDCAM-compatible). For information on file formats that are supported by specific codecs, please visit the [Product Details](#) page.

*Amazon Elastic Transcoder FAQs*, AMAZON AWS DOCUMENTATION, *available at:* <https://aws.amazon.com/elastictranscoder/faqs/> (“We support the following video codecs: H.264, VP9 . . .”).

493. The ability to encode video and image content in compliance with the VP9 standard is described in Amazon documentation as a reason why one needs to use Amazon Elastic Transcoder.

**Why should you stay on Amazon Elastic Transcoder?**

For the small set of features listed below, you still need to use Amazon Elastic Transcoder.

These features are:

- WebM (VP8/VP9) input and output
- Animated GIF output
- MP4 auto-rotation flag support
- MP3, FLAC, Vorbis, and WAV audio-only output
- Encryption support using KMS integration

Jeremy Johnson, *How to Migrate Workflows from Amazon Elastic Transcoder to AWS Elemental MediaConvert*, AMAZON AWS DOCUMENTATION (June 26, 2018), available at: <https://aws.amazon.com/blogs/media/how-to-migrate-workflows-from-amazon-elastic-transcoder-to-aws-elemental-mediaconvert/>

494. The Amazon Fire TV Stick 4K enables the output of VP9 encoded content at upto 60 frames per second.

**4K Specifications**

Specifications related to 4K features are provided in the table below. (This section appears only for 4K-capable devices.)

Fire TV Stick 4K

Item	Details
Resolution and Refresh Rate	- HEVC 4K UHD up to 60 fps - AVC 4K UHD up to 60 fps - VP9 4K UHD up to 60 fps

*Device Specifications for Fire TV*, AMAZON DEVELOPER DOCUMENTATION, available at: <https://developer.amazon.com/docs/fire-tv/device-specifications.html>

495. On information and belief, the Amazon '227 Products estimate a motion vector field for an image signal.

## Coding Tools: Segmentation



- Segmentation feature significantly enhanced in VP9
  - Groups together blocks that share common characteristics into segments.
  - Indicate segmentation id at block level
    - Differentially encode segmentation map temporally
  - Encode control flags/features at segment level.
    - Q, loop filter strength, ref frame, skip mode
  
- Unlocking the true potential requires a smart encoder
  - Syntax provides a framework for encoding innovation
  - Various psychovisual optimizations possible

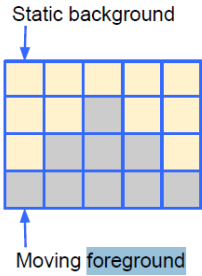

Debargha Mukherjee, A TECHNICAL OVERVIEW OF VP9: THE LATEST ROYALTY FREE VIDEO CODEC FROM GOOGLE (2016)).

496. On information and belief, the Amazon '227 Products detect edges in the motion vector field.

497. On information and belief, Amazon has directly infringed and continues to directly infringe the '227 patent by, among other things, making, using, offering for sale, and/or selling technology for detecting occlusion and reducing halo effects in motion compensated pictures, including but not limited to the Amazon '227 Products.

498. On information and belief, one or more of the Amazon '227 Products perform a method of locating problem areas in an image signal that includes estimating a motion vector field for the image signal.

499. On information and belief, one or more of the Amazon '227 Products perform a method of locating problem areas in an image signal that includes detecting edges in the motion vectors field.

500. On information and belief, one or more of the Amazon '227 Products perform a method of locating problem areas in an image signal that includes comparing edge locations in successive field periods to identify both foreground and background.

In the reference implementation, segmentation is currently used to identify background and foreground areas in encoded video content. The (static) background is then coded at a higher quality compared to the rest of the frame in certain reference frames (such as the alt-ref frame) that provides prediction that persists over a number of frames. In contrast, for the frames between these persistent reference frames, the background is given fewer bits by, for example, restricting the set of available reference buffers, using only the ZERO\_MV coding mode, or skipping the residual coefficient block. The result is that more bits are available to code the foreground-portion of the scene, while still preserving very good perceptual quality on the static background. Other use cases involving spatial and temporal masking for perceptual quality improvement are conceivable.

*A VP9 Bitstream Overview*, NETWORK WORKING GROUP § 2.8 (February 18, 2013).

501. On information and belief, the Amazon '227 Products are available to businesses and individuals throughout the United States.

502. On information and belief, the Amazon '227 Products are provided to businesses and individuals located in the Eastern District of Texas.

503. By making, using, testing, offering for sale, and/or selling products and services for detecting occlusion and reducing halo effects in motion compensated pictures, including but not limited to the Amazon '227 Products, Amazon has injured Dynamic Data and is liable to the Plaintiff for directly infringing one or more claims of the '227 patent, including at least claim 1 pursuant to 35 U.S.C. § 271(a).

504. On information and belief, Amazon also indirectly infringes the '227 patent by actively inducing infringement under 35 U.S.C. § 271(b).

505. Amazon has had knowledge of the '227 patent since at least service of this First Amended Complaint or shortly thereafter, and on information and belief, Amazon knew of the '227 patent and knew of its infringement, including by way of this lawsuit.



506. On information and belief, Amazon intended to induce patent infringement by third-party customers and users of the Amazon '227 Products and had knowledge that the inducing acts would cause infringement or was willfully blind to the possibility that its inducing acts would cause infringement. Amazon specifically intended and was aware that the normal and customary use of the accused products would infringe the '227 patent. Amazon performed the acts that constitute induced infringement, and would induce actual infringement, with knowledge of the '227 patent and with the knowledge that the induced acts would constitute infringement. For example, Amazon provides the Amazon '227 Products that have the capability of operating in a manner that infringe one or more of the claims of the '227 patent, including at least claim 1, and Amazon further provides documentation and training materials that cause customers and end users of the Amazon '227 Products to utilize the products in a manner that directly infringe one or more claims of the '227 patent.<sup>37</sup> By providing instruction and training to customers and end-users on how to use the Amazon '227 Products in a manner that directly infringes one or more claims of the '227 patent, including at least claim 1, Amazon specifically intended to induce infringement of the '227 patent. On information and belief, Amazon engaged in such inducement to promote the sales of the Amazon '227 Products, e.g., through Amazon user manuals, product support, marketing materials, and training materials to actively induce the users of the accused products to infringe the '227 patent. Accordingly, Amazon has induced and continues to induce users of the

---

<sup>37</sup> See, e.g., *Amazon Elastic Transcoder*, DEVELOPER GUIDE API VERSION 2012-09-25 (Nov. 17, 2016); *Amazon Web Services*, GENERAL REFERENCE VERSION 1.0 (2018); Lee Atkinson, *Delivering Media & Entertainment using the AWS Cloud*, AWS TRANSFORMATION DAY GERMANY PRESENTATION (Oct. 25, 2017); *Fire TV Stick*, AMAZON USER GUIDE; *Watching Video in 4K Ultra HD on Fire TV*, AMAZON HELP WEBSITE, available at: <https://www.amazon.com/gp/help/customer/display.html?nodeId=201859000> (last visited Nov. 2018); *Amazon Fire TV*, AMAZON USER GUIDE.

accused products to use the accused products in their ordinary and customary way to infringe the '227 patent, knowing that such use constitutes infringement of the '227 patent.

507. The '227 patent is well-known within the industry as demonstrated by multiple citations to the '227 patent in published patents and patent applications assigned to technology companies and academic institutions. Amazon is utilizing the technology claimed in the '227 patent without paying a reasonable royalty. Amazon is infringing the '227 patent in a manner best described as willful, wanton, malicious, in bad faith, deliberate, consciously wrongful, flagrant, or characteristic of a pirate.

508. To the extent applicable, the requirements of 35 U.S.C. § 287(a) have been met with respect to the '227 patent. As a result of Amazon's infringement of the '227 patent, Dynamic Data has suffered monetary damages, and seeks recovery in an amount adequate to compensate for Amazon's infringement, but in no event less than a reasonable royalty for the use made of the invention by Amazon together with interest and costs as fixed by the Court.

**COUNT XIV**  
**INFRINGEMENT OF U.S. PATENT NO. 8,189,105**

509. Dynamic Data references and incorporates by reference the preceding paragraphs of this Complaint as if fully set forth herein.

510. Amazon designs, makes, uses, sells, and/or offers for sale in the United States products and/or services for motion compensation in video signal processing.

511. Amazon designs, makes, uses, sells, and/or offers for sale in the United States products and/or services for processing pixel information based on received motion and edge data.

512. Amazon designs, makes, sells, offers to sell, imports, and/or uses Amazon products capable of decoding video data in compliance with the H.265 standard. By way of example, the

following Amazon Products perform decoding pursuant to the H.265 standard: the Amazon Web Services platform (e.g., AWS Elastic Transcoder, AWS Elemental MediaConvert, AWS Elemental MediaLive, Amazon EC2 Accelerated Compute (EC2 G3 Instances), Amazon CloudFront); Amazon Fire TV products (e.g., Fire TV Stick 4k, Fire TV Cube, Fire TV (Gen 3), Fire TV (Gen 2), Fire TV Edition - Toshiba 4K (2018), Fire TV Edition - Element 4K (2018), Fire TV Edition - Insignia HD (2018), Fire TV Edition - Insignia 4k (2018), Fire TV Edition - Toshiba HD (2018)); and Amazon Fire Tablet products (e.g., Fire HD 8 (2018), Fire HD 10 (2017), Fire HD 8 (2017), Fire 7 (2017), Fire HD 8 (2016), Fire HD 8 (2015), Fire HD 10 (2015)) (collectively, the “Amazon ‘105 Product(s)”).

513. On information and belief, one or more Amazon subsidiaries and/or affiliates use the Amazon ‘105 Products in regular business operations.

514. On information and belief, the Amazon ‘105 Products perform video processing compliant with the HEVC standard.

515. The accused Amazon Web Services platform products (e.g., AWS Elastic Transcoder, AWS Elemental MediaConvert, AWS Elemental MediaLive, Amazon EC2 Accelerated Compute (EC2 G3 Instances), and Amazon CloudFront) comply with the HEVC image processing standard. As shown in the following excerpts from Amazon Documentation the accused Amazon Web Services Platform functionalities comply with the HEVC standard.

Until recently, H.264 (also known as AVC) was the best codec for optimizing quality and reducing file sizes; many content publishers still use it today. But it’s quickly giving way to HEVC: High-Efficiency Video Coding. It’s also referred to as H.265; different standards groups employ different designations to refer to the same standard. HEVC requires more computing power than H.264, but it’s more efficient. Because AWS Elemental writes all of its encoding software from scratch, rather than relying on off-the-shelf encoding software, it is able to take the efficiency gains in each new generation of codec and adjust the software accordingly to get the best quality and/ or smallest video file sizes, along with the shortest encoding times.

Alicia Hunt, *A Video Compression Primer*, AWS MEDIA BLOG (January 30, 2019), available at: <https://aws.amazon.com/blogs/media/a-video-compression-primer/> (emphasis added).

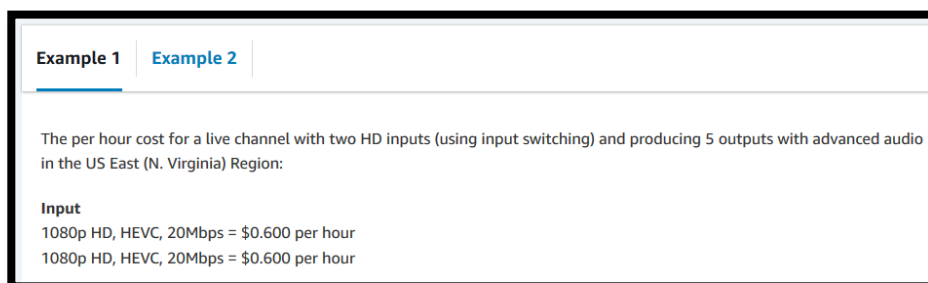

The screenshot shows a pricing table for AWS MediaLive. It has two tabs: 'Example 1' (selected) and 'Example 2'. Below the tabs, it states: 'The per hour cost for a live channel with two HD inputs (using input switching) and producing 5 outputs with advanced audio in the US East (N. Virginia) Region:'. Under the heading 'Input', there are two entries: '1080p HD, HEVC, 20Mbps = \$0.600 per hour' and '1080p HD, HEVC, 20Mbps = \$0.600 per hour'.

*AWS Elemental MediaLive Pricing*, AWS DOCUMENTATION, available at: <https://aws.amazon.com/medialive/pricing/>

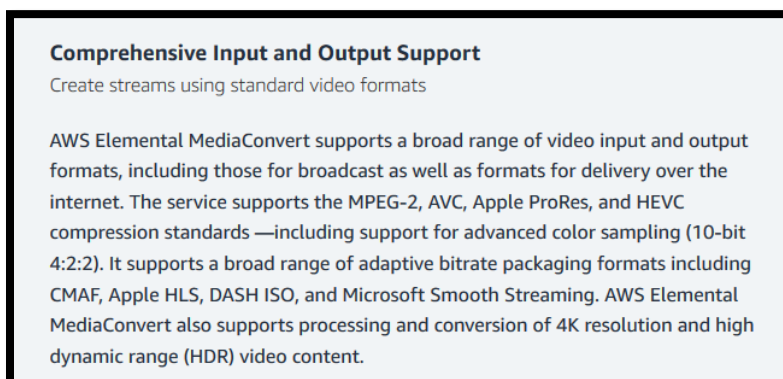

The screenshot is titled 'Comprehensive Input and Output Support' and says 'Create streams using standard video formats'. The main text reads: 'AWS Elemental MediaConvert supports a broad range of video input and output formats, including those for broadcast as well as formats for delivery over the internet. The service supports the MPEG-2, AVC, Apple ProRes, and HEVC compression standards—including support for advanced color sampling (10-bit 4:2:2). It supports a broad range of adaptive bitrate packaging formats including CMAF, Apple HLS, DASH ISO, and Microsoft Smooth Streaming. AWS Elemental MediaConvert also supports processing and conversion of 4K resolution and high dynamic range (HDR) video content.'

*AWS Elemental MediaConvert*, AWS DOCUMENTATION, available at: <https://aws.amazon.com/mediaconvert/features/> (AWS Elemental MediaConvert supports a broad range of video input and output formats . . . [t]he service supports . . . HEVC compression standards.”).

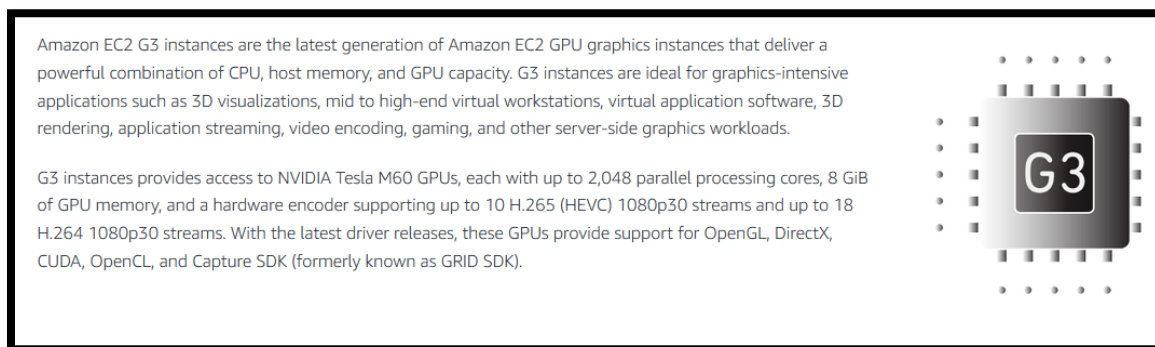

The screenshot describes Amazon EC2 G3 instances. The text says: 'Amazon EC2 G3 instances are the latest generation of Amazon EC2 GPU graphics instances that deliver a powerful combination of CPU, host memory, and GPU capacity. G3 instances are ideal for graphics-intensive applications such as 3D visualizations, mid to high-end virtual workstations, virtual application software, 3D rendering, application streaming, video encoding, gaming, and other server-side graphics workloads.' Below this, it lists specifications: 'G3 instances provides access to NVIDIA Tesla M60 GPUs, each with up to 2,048 parallel processing cores, 8 GiB of GPU memory, and a hardware encoder supporting up to 10 H.265 (HEVC) 1080p30 streams and up to 18 H.264 1080p30 streams. With the latest driver releases, these GPUs provide support for OpenGL, DirectX, CUDA, OpenCL, and Capture SDK (formerly known as GRID SDK).' To the right of the text is a graphic of a GPU chip with 'G3' on it.

*Amazon EC2 G3 Instances*, AWS DOCUMENTATION, available at: <https://aws.amazon.com/ec2/instance-types/g3/> (“G3 instances provides access to NVIDIA Tesla M60 GPUs, each with up to 2,048 parallel processing cores, 8 GiB of GPU memory, and a hardware encoder supporting up to 10 H.265 (HEVC) 1080p30 streams and up to 18 H.264 1080p30 streams.”).

516. The accused Amazon Fire TV Products (e.g., Fire TV Stick 4k, Fire TV Cube, Fire TV (Gen 3), Fire TV (Gen 2), Fire TV Edition - Toshiba 4K (2018), Fire TV Edition - Element 4K (2018), Fire TV Edition - Insignia HD (2018), Fire TV Edition - Insignia 4k (2018), Fire TV Edition - Toshiba HD (2018)) comply with the HEVC image processing standard. The below excerpt from Amazon Fire TV Developer documentation describes the accused Amazon Fire TV Products as complying with the requirements of the HEVC standard.

Fire TV Stick 4K			
Type	Codec	MIME type	Details
<b>Video</b>	H.265 (HEVC) (High Efficiency Video Coding)	video/hevc	Hardware accelerated up to 3840x2160p (4K) @ 60fps, 35 Mbps, Main 10 Profile Level 5.1, Color space 8-bit and 10-bit input with HDR10, HDR10+, HLG, and Dolby Vision support in rendering pipelines.

*Device Specifications for Fire TV, AMAZON DEVELOPER DOCUMENTATION, available at: <https://developer.amazon.com/docs/fire-tv/device-specifications.html> (describing the HEVC encoding and decoding support for the Amazon Fire TV Products).*

517. The accused Amazon Fire Tablet Products (e.g., Fire HD 8 (2018), Fire HD 10 (2017), Fire HD 8 (2017), Fire 7 (2017), Fire HD 8 (2016), Fire HD 8 (2015), Fire HD 10 (2015)) comply with the HEVC image processing standard. The below excerpt from Amazon Fire Tablet Developer documentation describes the accused Amazon Fire Tablet Products as complying with the requirements of the HEVC standard.

H.264 AVC	D (HW) High profile, L4.1 1080p@30FPS, E (HW)	D (HW) High profile, L4.1 Main Profile@L4 1080p@30FPS/4 0Mbps, E (HW)	D (HW) High profile, L4.1 Main Profile@L4 1080p@30FPS/4 0Mbps, E (HW)	D (HW) High profile, L4.1 1080p@30FPS, E (HW)
H.265 HEVC	D(HW) Main Profile L4 1080p@30FPS	D (HW) Main Profile L4 Main Profile@L4 1080p@30FPS/4 0Mbps	D (HW) Main Profile L4 Main Profile@L4 1080p@30FPS/4 0Mbps	D(HW) Main Profile L4 1080p@30FPS

*Amazon Fire TV Tablet Media Specifications*, AMAZON DEVELOPER DOCUMENTATION, available at: <https://developer.amazon.com/docs/fire-tablets/ft-media-specs-custom.html> (showing that the Fire HD 8 (2018), Fire HD 10 (2017), Fire HD 8 (2017) and Fire 7 (2017) support H.265 encoding compliant with the standard).

518. On information and belief, by complying with the HEVC standard, the Amazon devices – such as the Amazon ‘105 Products – necessarily infringe the ‘105 patent. The mandatory sections of the HEVC standard require the elements required by certain claims of the ‘105 patent, including but not limited to claim 1 of the ‘105 patent. *High Efficiency Video Coding*, SERIES H: AUDIOVISUAL AND Multimedia SYSTEMS: INFRASTRUCTURE OF AUDIOVISUAL SERVICES – CODING OF MOVING VIDEO REC. ITU-T H.265 (February 2018) (The following sections of the HEVC Standard are relevant to Amazon’s infringement of the ‘105 patent: “8.3.2 Decoding process for reference picture set;” “8.5.4 Decoding process for the residual signal of coding units coded in inter prediction mode;” “8.6 Scaling, transformation and array construction process prior to deblocking filter process;” “8.5.2 Inter prediction process;” “8.5.3 Decoding process for prediction units in inter prediction mode;” and “8.7.2 Deblocking filter process;” “8.7.3 Sample adaptive offset process.”).

519. On information and belief, the Amazon ‘105 Products comply with the HEVC standard, which requires processing edge data from edge-adaptive interpolation processing.

520. The Amazon ‘105 Products use two types of prediction methods for processing pixel information when encoding and decoding video data in HEVC format: inter prediction and intra prediction. Inter prediction utilizes motion vectors for block-based inter prediction to exploit temporal statistical dependencies between different pictures. Intra prediction uses various spatial prediction modes to exploit spatial statistical dependencies in the source signal for a single picture. The HEVC Specification (*e.g.*, *High Efficiency Video Coding*, SERIES H: AUDIOVISUAL AND MULTIMEDIA SYSTEMS: INFRASTRUCTURE OF AUDIOVISUAL SERVICES – CODING OF MOVING VIDEO REC. ITU-T H.265 (February 2018) sets forth the standard that is followed by HEVC compliant devices such as the Amazon ‘105 Products, and is relevant to both decoding and encoding that are performed pursuant to the HEVC standard. For instance, the Amazon ‘105 Products perform a method for encoding a video signal comprised of pixels using motion vectors when performing encoding of H.265/HEVC video data.

521. During the encoding process the Amazon ‘105 products process pixel information based on edge data. The edge data is generated by the Amazon ‘105 products using merge mode estimation. Specifically, the Amazon ‘105 Products generate merge estimation regions which identify edge information within a video frame. The merge estimation regions are comprised of prediction units (“PU”) that contain luma values. For example, in the below diagram PUs are shown. The encoding process then identifies along the edges of each prediction unit a merge estimation region (“MER”). The MER regions thus identify the edges and the PU contains the intensity estimate for the pixels.

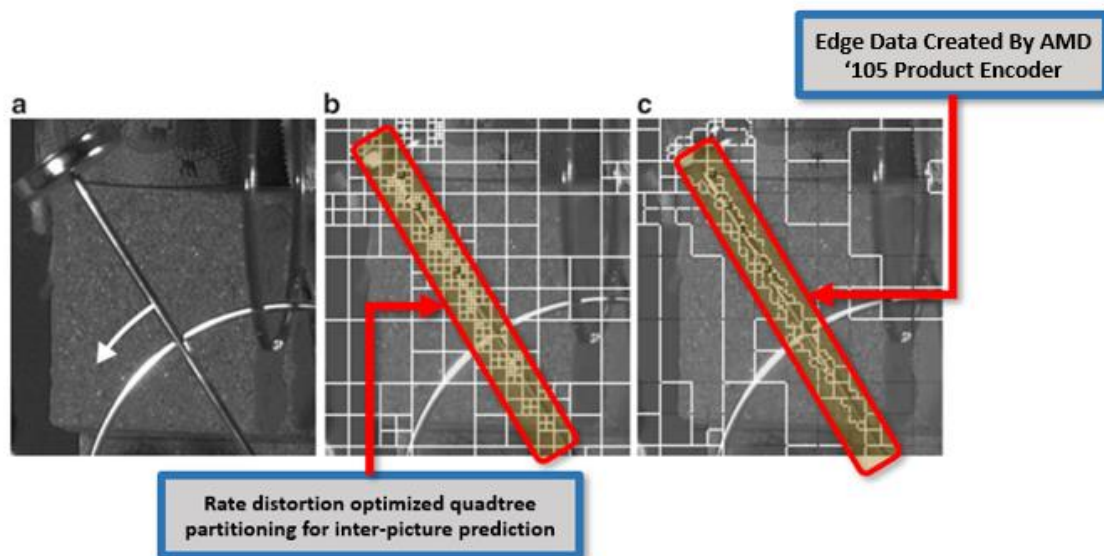

Benjamin Bross et al, *Inter-Picture Prediction in HEVC*, HIGH EFFICIENCY VIDEO CODING (HEVC) at 114 (September 2014) (annotations added).

522. The Amazon '105 Products in the process of encoding video content in HEVC format generate merge estimation regions generate edge data that include luma location and luma values which include a first intensity estimate. The HEVC standards describes this process as leading to the generation of luma motion vector  $mvL0$  and  $mvL1$ .

[T]he derivation process for luma motion vectors for merge mode as specified in clause I.8.5.3.2.7 is invoked with the luma location (  $xCb$ ,  $yCb$  ), the luma location (  $xPb$ ,  $yPb$  ), the variables  $nCbS$ ,  $nPbW$ ,  $nPbH$ , and the partition index  $partIdx$  as inputs, and the output being the luma motion vectors  $mvL0$ ,  $mvL1$ , the reference indices  $refIdxL0$ ,  $refIdxL1$ , the prediction list utilization flags  $predFlagL0$  and  $predFlagL1$ , the flag  $ivMcFlag$ , the flag  $vspMcFlag$ , and the flag  $subPbMotionFlag$ .

*High Efficiency Video Coding*, SERIES H: AUDIOVISUAL AND MULTIMEDIA SYSTEMS: INFRASTRUCTURE OF AUDIOVISUAL SERVICES – CODING OF MOVING VIDEO REC. ITU-T H.265 at § I.8.5.3.2.1 (February 2018) (emphasis added).

523. The Amazon '105 Products perform the step of processing edge data from an edge adaptive interpolation process wherein the edge data includes a first intensity estimate of the pixel. Specifically, the Amazon '105 Products implement HEVC encoding which utilizes Parallel Merge Mode and Merge Estimation Regions (MER's) within the interpolation process to determine pixel



edges. Parallel Merge Mode Estimation identifies the edge data within a prediction unit. The below diagram shows how video data is portioned into 10 prediction units and edge data is calculated and passed to the encoder.

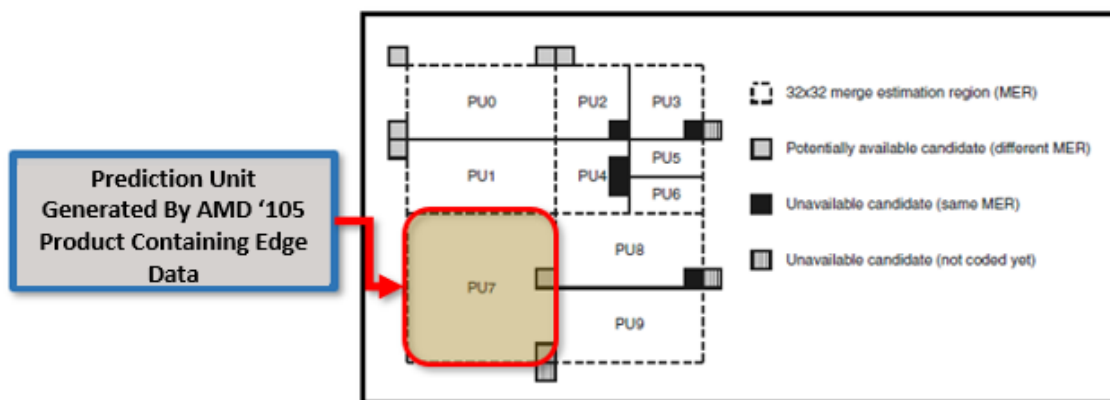

Benjamin Bross et al, *Inter-Picture Prediction in HEVC*, HIGH EFFICIENCY VIDEO CODING (HEVC) at 127 (September 2014) (annotations added).

524. The merge estimation processes implemented by the Amazon ‘105 Products is “adaptive.” The below excerpt from documentation regarding the HEVC encoding process describes that the “merge estimation level is adaptive.”

In order to enable an encoder to trade-off parallelism and coding efficiency, the parallel merge estimation level is adaptive and signaled as `log2_parallel_merge_level_minus2` in the picture parameter set. The following MER sizes are allowed: 4x4 (no parallel merge estimation possible), 8x8, 16x16, 32x32 and 64x64. A higher degree of parallelization, enabled by a larger MER, excludes more potential candidates from the merge candidate list.

Benjamin Bross et al, *Inter-Picture Prediction in HEVC*, HIGH EFFICIENCY VIDEO CODING (HEVC) at 128 (September 2014) (emphasis added).

525. The edge data that is processed from the edge adaptive interpolation process includes intensity estimates for pixels such as pixels in the merge estimation region. The intensity estimate or brightness estimate is referred to as “luma” in the encoding functionality implemented by the AMAZON ‘105 Products.

For representing color video signals, HEVC typically uses a tristimulus YCbCr color space with 4:2:0 sampling (although extension to other sampling formats is straightforward, and is planned to be defined in a subsequent version). This separates a color representation into three components called Y, Cb, and Cr. The Y component is also called luma, and represents brightness. The two chroma components Cb and Cr represent the extent to which the color deviates from gray toward blue and red, respectively. Because the human visual system is more

Gary J. Sullivan, Jens-Rainer Ohm, Woo-Jin Han, and Thomas Wiegand, Fellow, IEEE, *Overview of the High Efficiency Video Coding (HEVC) Standard*, published in IEEE TRANSACTIONS ON CIRCUITS AND SYSTEMS FOR VIDEO TECHNOLOGY, Vol. 22, No. 12 at 1654 (December 2012) (emphasis added).

526. The motion estimation region (“MER”) is an adaptive interpolation process in which the edges of images are calculated and include the intensity estimates of pixels by way of a luma value. The below excerpt from the HEVC specification describes how during the generation of merge estimation regions edge data includes luminosity values (intensity estimates) for pixels within a region.

**8.5.3.2.3 Derivation process for spatial merging candidates**

Inputs to this process are:

- a luma location (  $x_{Cb}$ ,  $y_{Cb}$  ) of the top-left sample of the current luma coding block relative to the top-left luma sample of the current picture,
- a variable  $nCbS$  specifying the size of the current luma coding block,
- a luma location (  $x_{Pb}$ ,  $y_{Pb}$  ) specifying the top-left sample of the current luma prediction block relative to the top-left luma sample of the current picture,
- two variables  $nPbW$  and  $nPbH$  specifying the width and the height of the luma prediction block,
- a variable  $partIdx$  specifying the index of the current prediction unit within the current coding unit.

Outputs of this process are as follows, with  $X$  being 0 or 1:

- the availability flags  $availableFlagA_0$ ,  $availableFlagA_1$ ,  $availableFlagB_0$ ,  $availableFlagB_1$  and  $availableFlagB_2$  of the neighbouring prediction units,
- the reference indices  $refIdxLXA_0$ ,  $refIdxLXA_1$ ,  $refIdxLXB_0$ ,  $refIdxLXB_1$  and  $refIdxLXB_2$  of the neighbouring prediction units,
- the prediction list utilization flags  $predFlagLXA_0$ ,  $predFlagLXA_1$ ,  $predFlagLXB_0$ ,  $predFlagLXB_1$  and  $predFlagLXB_2$  of the neighbouring prediction units,
- the motion vectors  $mvLXA_0$ ,  $mvLXA_1$ ,  $mvLXB_0$ ,  $mvLXB_1$  and  $mvLXB_2$  of the neighbouring prediction units.

*High Efficiency Video Coding, Series H: Audiovisual And Multimedia Systems: Infrastructure Of Audiovisual Services – Coding Of Moving Video Rec. ITU-T H.265 at § I.8.5.2.3 (February 2018) (attached hereto as Exhibit 8) (emphasis added).*

527. The Amazon ‘105 Products process motion data associated with motion compensation. The motion data processed by the Amazon ‘105 Products include a first estimated

motion vector of pixels within a reference frame prior to the current frame and a second estimated motion vector within the reference field after the current field. Specifically, the Amazon ‘105 products generate motion data in the form of a bi-directional prediction unit (PU) which has two motion vectors (referencing a prior frame and a subsequent frame in the sequence). The two motion vectors are combined to make a “bi-predictive merge candidate.” One of the motion vectors is obtained from “reference picture list0” and the other motion vector is obtained from “reference picture list1.”

#### 8.5.3.3.2 Reference picture selection process

Input to this process is a reference index  $refIdxLX$ .

Output of this process is a reference picture consisting of a two-dimensional array of luma samples  $refPicLX_L$ , and, when  $ChromaArrayType$  is not equal to 0, two two-dimensional arrays of chroma samples  $refPicLX_Cb$  and  $refPicLX_Cr$ .

The output reference picture  $RefPicListX[refIdxLX]$  consists of a  $pic\_width\_in\_luma\_samples$  by  $pic\_height\_in\_luma\_samples$  array of luma samples  $refPicLX_L$  and, when  $ChromaArrayType$  is not equal to 0, two  $PicWidthInSamplesC$  by  $PicHeightInSamplesC$  arrays of chroma samples  $refPicLX_Cb$  and  $refPicLX_Cr$ .

The reference picture sample arrays  $refPicLX_L$ ,  $refPicLX_Cb$ , and  $refPicLX_Cr$  correspond to decoded sample arrays  $S_L$ ,  $S_Cb$ , and  $S_Cr$  derived in clause 8.7 for a previously-decoded picture.

*High Efficiency Video Coding, SERIES H: AUDIOVISUAL AND MULTIMEDIA SYSTEMS: INFRASTRUCTURE OF AUDIOVISUAL SERVICES – CODING OF MOVING VIDEO REC. ITU-T H.265 at § I.8.5.3.3 (February 2018).*

528. The reference pictures that are used to generate a motion vector comprise both the forward and prior reference pictures which are referred to in the HEVC encoding process implemented by the Amazon ‘105 Products as “refPicLXcb” and “refPicLXcr.” The following excerpt describing the implementation of the encoding process in the Amazon ‘105 Products which use bi-predictive slices.

Since a merge candidate comprises all motion data and the TMVP is only one motion vector, the derivation of the whole motion data only depends on the slice type. For bi-predictive slices, a TMVP is derived for each reference picture list. Depending on the availability of the TMVP for each list, the prediction type is set to bi-prediction or to the list for which the TMVP is available. All associated reference picture indices are set equal to zero. Consequently for uni-predictive slices, only the TMVP for list 0 is derived together with the reference picture index equal to zero.

Benjamin Bross et al, *Inter-Picture Prediction in HEVC*, HIGH EFFICIENCY VIDEO CODING (HEVC) at 123 (September 2014) (emphasis added) (describing the use of bi-prediction in which motion data is derived from the forward and prior reference pictures in generating temporal arrays/vectors).

529. The Amazon ‘105 Products interpolation process contains bi-prediction functionality that computes a first estimated motion prediction and a second estimated motion prediction. The below excerpt from documentation of the encoding method used by the Amazon ‘105 products describes that the encoding process includes functionality for generating a second intensity estimate for the pixel data and the edge data determined according to motion. In bi-prediction, the second estimate is defined as  $\Delta x_1, \Delta y_1, \Delta t_1$ .

In case of bi-prediction, two sets of motion data ( $\Delta x_0, \Delta y_0, \Delta t_0$  and  $\Delta x_1, \Delta y_1, \Delta t_1$ ) are used to generate two MCPs (possibly from different pictures), which are then combined to get the final MCP. Per default, this is done by averaging but in case of weighted prediction, different weights can be applied to each MCP, e.g. to compensate for scene fade outs. The reference pictures that can be used in bi-prediction are stored in two separate lists, namely list 0 and list 1. In order to limit the memory bandwidth in slices allowing bi-prediction, the HEVC standard restricts PUs with  $4 \times 8$  and  $8 \times 4$  luma prediction blocks to use uni-prediction only. Motion data is derived at the encoder using a motion estimation process. Motion

Benjamin Bross et al, *Inter-Picture Prediction in HEVC*, HIGH EFFICIENCY VIDEO CODING (HEVC) at 114 (September 2014) (emphasis added).

530. In AMVP the system generates a temporal intermediate candidate based on bi-directional motion data. The “inter\_pred\_idc [x0] [y0] specifies whether list0, list1, or bi-prediction is used for the current prediction unit” according to the below referenced table. “The array indices x0, y0 specify the location (x0, y0) of the top-left luma sample of the considered prediction block relative to the top-left luma sample of the picture.”

**Table 7-11 – Name association to inter prediction mode**

inter_pred_idc	Name of inter_pred_idc	
	(nPbW + nPbH) != 12	(nPbW + nPbH) == 12
0	PRED_L0	PRED_L0
1	PRED_L1	PRED_L1
2	PRED_BI	na

*High Efficiency Video Coding, SERIES H: AUDIOVISUAL AND MULTIMEDIA SYSTEMS: INFRASTRUCTURE OF AUDIOVISUAL SERVICES – CODING OF MOVING VIDEO REC. ITU-T H.265 at § 7.4.9.6 (February 2018).*

531. The Amazon ‘105 products generate a second intensity estimate based on the edge data and the motion data. The edge data is combined with the temporal intermediate candidate to generate the temporal candidate. The prediction unit based on the first and second motion vector (motion data) is then combined with the edge data to generate a second intensity estimate. Once the reference picture for obtaining the co-located PU is selected then the position of the co-located Pu will be selected among two candidate positions. A second intensity estimate is generated by using the bi-directional motion vectors and the edge data. The below excerpt from the HEVC specification describes that for a luma motion vector prediction the generation of a second intensity estimate is based on the motion data and the edge data. The edge data here is comprised by the luma location and luma prediction block information. Further, the luma motion vectors mvLO and mvL1 are combined with the edge data including luma location xCB yCB xBL and yBL to generate a second intensity estimate.

**8.5.3.2.6 Derivation process for luma motion vector prediction**

Inputs to this process are:

- a luma location (  $x_{Cb}$ ,  $y_{Cb}$  ) of the top-left sample of the current luma coding block relative to the top-left luma sample of the current picture,
- a variable  $nCbS$  specifying the size of the current luma coding block,
- a luma location (  $x_{Pb}$ ,  $y_{Pb}$  ) specifying the top-left sample of the current luma prediction block relative to the top-left luma sample of the current picture,
- two variables  $nPbW$  and  $nPbH$  specifying the width and the height of the luma prediction block,
- the reference index of the current prediction unit partition  $refIdxLX$ , with  $X$  being 0 or 1,
- a variable  $partIdx$  specifying the index of the current prediction unit within the current coding unit.

Output of this process is the prediction  $mv_{pLX}$  of the motion vector  $mvLX$ , with  $X$  being 0 or 1.

*High Efficiency Video Coding, SERIES H: AUDIOVISUAL AND MULTIMEDIA SYSTEMS: INFRASTRUCTURE OF AUDIOVISUAL SERVICES – CODING OF MOVING VIDEO REC. ITU-T H.265 at § 8.5.3.2.6 (February 2018) (emphasis added).*

**8.5.3.3.1 General**

Inputs to this process are:

- a luma location (  $x_{Cb}$ ,  $y_{Cb}$  ) specifying the top-left sample of the current luma coding block relative to the top-left luma sample of the current picture,
- a luma location (  $x_{Pb}$ ,  $y_{Pb}$  ) specifying the top-left sample of the current luma prediction block relative to the top-left sample of the current luma coding block,
- a variable  $nCbS$  specifying the size of the current luma coding block,
- two variables  $nPbW$  and  $nPbH$  specifying the width and the height of the luma prediction block,
- the luma motion vectors  $mvL0$  and  $mvL1$ ,
- when  $ChromaArrayType$  is not equal to 0, the chroma motion vectors  $mvCL0$  and  $mvCL1$ ,
- the reference indices  $refIdxL0$  and  $refIdxL1$ ,
- the prediction list utilization flags,  $predFlagL0$ , and  $predFlagL1$ .

Outputs of this process are:

- an  $(nCbS_L) \times (nCbS_L)$  array  $predSamples_L$  of luma prediction samples, where  $nCbS_L$  is derived as specified below,
- when  $ChromaArrayType$  is not equal to 0, an  $(nCbSw_C) \times (nCbSh_C)$  array  $predSamples_{Cb}$  of chroma prediction samples for the component  $Cb$ , where  $nCbSw_C$  and  $nCbSh_C$  are derived as specified below,

*High Efficiency Video Coding, SERIES H: AUDIOVISUAL AND MULTIMEDIA SYSTEMS: INFRASTRUCTURE OF AUDIOVISUAL SERVICES – CODING OF MOVING VIDEO REC. ITU-T H.265 at § 8.5.3.3.1 (February 2018) (emphasis added).*

532. The Amazon ‘105 Products perform a mixing process in which the final edge/motion data of a pixel is calculated based on a first intensity estimate, second intensity estimate, and motion reliability data. Specifically, the Amazon ‘105 Products encode pixel data using bi-prediction wherein use two types of mixing functions: average mixing and weighted mixing.



In case of bi-prediction, two sets of motion data ( $\Delta x_0, \Delta y_0, \Delta t_0$  and  $\Delta x_1, \Delta y_1, \Delta t_1$ ) are used to generate two MCPs (possibly from different pictures), which are then combined to get the final MCP. Per default, this is done by averaging but in case of weighted prediction, different weights can be applied to each MCP, e.g. to compensate for scene fade outs. The reference pictures that can be used in bi-prediction are stored in two separate lists, namely list 0 and list 1. In order to limit the memory bandwidth in slices allowing bi-prediction, the HEVC standard restricts PUs with  $4 \times 8$  and  $8 \times 4$  luma prediction blocks to use uni-prediction only. Motion data is derived at the encoder using a motion estimation process. Motion

Benjamin Bross et al, *Inter-Picture Prediction in HEVC*, HIGH EFFICIENCY VIDEO CODING (HEVC) at 123 (September 2014) (emphasis added).

533. The HEVC standard includes functionality to perform a mixing process. In MERGE mode, an up-to five-entry MERGE candidate list is first constructed with four (MV, Refldx) pairs from spatial neighbor blocks and one (MV, Refldx) pair from temporal bottom-right or collocated neighbor block, where Refldx is the index of the reference picture that the MV pointed to. After that, the encoder decides to use which candidate (MV, Refldx) pair to encode current block and then encode the candidate index into bitstream. In MERGE mode, the selected (MV, Refldx) pair is directly used to encode current block, and no MVD information needs to be coded. The number of merge candidates could be configured at encoder, with up to five merge candidates.”

#### 8.5.3.3.4 Weighted sample prediction process

##### 8.5.3.3.4.1 General

Inputs to this process are:

- two variables nPbW and nPbH specifying the width and the height of the current prediction block,
- two (nPbW)x(nPbH) arrays predSamplesL0 and predSamplesL1,
- the prediction list utilization flags, predFlagL0 and predFlagL1,
- the reference indices refldxL0 and refldxL1,
- a variable cIdx specifying colour component index.

Output of this process is the (nPbW)x(nPbH) array pbSamples of prediction sample values.

*HIGH EFFICIENCY VIDEO CODING, SERIES H: AUDIOVISUAL AND MULTIMEDIA SYSTEMS: INFRASTRUCTURE OF AUDIOVISUAL SERVICES – CODING OF MOVING VIDEO REC. ITU-T H.265 at § 8.5.3.3.4.1 (February 2018) (emphasis added).*

534. The variables predFlagL0 and predFlagL1 are reliability values that are generated by the decoding process. The predFlagL0 and L1 values are prediction utilization values that are used to generate prediction utilization and reliability of the vectors.

The decoding process for prediction units in inter prediction mode consists of the following ordered steps:

1. The derivation process for motion vector components and reference indices as specified in clause 8.5.3.2 is invoked with the luma coding block location ( xCb, yCb ), the luma prediction block location ( xBl, yBl ), the luma coding block size block nCbS, the luma prediction block width nPbW, the luma prediction block height nPbH and the prediction unit index partIdx as inputs, and the luma motion vectors mvL0 and mvL1, when ChromaArrayType is not equal to 0, the chroma motion vectors mvCL0 and mvCL1, the reference indices refIdxL0 and refIdxL1 and the prediction list utilization flags predFlagL0 and predFlagL1 as outputs.

*High Efficiency Video Coding, SERIES H: AUDIOVISUAL AND MULTIMEDIA SYSTEMS: INFRASTRUCTURE OF AUDIOVISUAL SERVICES – CODING OF MOVING VIDEO REC. ITU-T H.265 at § 8.5.3.1 (February 2018).*

535. On information and belief, any implementation of the HEVC standard would infringe the ‘105 patent as every possible implementation of the standard requires: processing edge data from edge-adaptive interpolation processing, including a first intensity estimate for the pixel as well as data pertaining to one or more pixels that neighbor the pixel; processing motion data associated with motion compensation processing, wherein the motion data includes a first estimated motion vector for a pixel in a reference field prior to the present field and a second estimated motion vector for a pixel in a reference field subsequent to the present field; determining a second intensity estimate for the pixel as a function of the edge data and the motion data; and performing a blending process wherein final edge/motion data of the pixel is calculated as a function of the first intensity estimate, the second intensity estimate, and motion reliability data characterizing reliability of the motion data.

536. On information and belief, the Amazon ‘105 Products are available to businesses and individuals throughout the United States.

537. On information and belief, the Amazon ‘105 Products are provided to businesses and individuals located in the Eastern District of Texas.



538. By making, using, testing, offering for sale, and/or selling products and services for enhancing subsequent images of a video stream in which frames are encoded based on previous frames using prediction and motion estimation, including but not limited to the Amazon ‘105 Products, Amazon has injured Dynamic Data and is liable to the Plaintiff for directly infringing one or more claims of the ‘105 patent, including at least claim 1 pursuant to 35 U.S.C. § 271(a).

539. On information and belief, Amazon also indirectly infringes the ‘105 patent by actively inducing infringement under 35 U.S.C. § 271(b).

540. Amazon has had knowledge of the ‘105 patent since at least service of this First Amended Complaint or shortly thereafter, and on information and belief, Amazon knew of the ‘105 patent and knew of its infringement, including by way of this lawsuit.

541. On information and belief, Amazon intended to induce patent infringement by third-party customers and users of the Amazon ‘105 Products and had knowledge that the inducing acts would cause infringement or was willfully blind to the possibility that its inducing acts would cause infringement. Amazon specifically intended and was aware that the normal and customary use of the accused products would infringe the ‘105 patent. Amazon performed the acts that constitute induced infringement, and would induce actual infringement, with knowledge of the ‘105 patent and with the knowledge that the induced acts would constitute infringement. For example, Amazon provides the Amazon ‘105 Products that have the capability of operating in a manner that infringe one or more of the claims of the ‘105 patent, including at least claim 1, and Amazon further provides documentation and training materials that cause customers and end users of the Amazon ‘105 Products to utilize the products in a manner that directly infringe one or more claims of the ‘105 patent.<sup>38</sup> By providing instruction and training to customers and end-users on

---

<sup>38</sup> See, e.g., *Amazon Elastic Transcoder*, DEVELOPER GUIDE API VERSION 2012-09-25 (Nov. 17, 2016); *Amazon Web Services*, GENERAL REFERENCE VERSION 1.0 (2018); Lee Atkinson,

how to use the Amazon ‘105 Products in a manner that directly infringes one or more claims of the ‘105 patent, including at least claim 1, Amazon specifically intended to induce infringement of the ‘105 patent. On information and belief, Amazon engaged in such inducement to promote the sales of the Amazon ‘105 Products, e.g., through Amazon user manuals, product support, marketing materials, and training materials to actively induce the users of the accused products to infringe the ‘105 patent. Accordingly, Amazon has induced and continues to induce users of the accused products to use the accused products in their ordinary and customary way to infringe the ‘105 patent, knowing that such use constitutes infringement of the ‘105 patent.

542. The ‘105 patent is well-known within the industry as demonstrated by multiple citations to the ‘105 patent in published patents and patent applications assigned to technology companies and academic institutions. Amazon is utilizing the technology claimed in the ‘105 patent without paying a reasonable royalty. Amazon is infringing the ‘105 patent in a manner best described as willful, wanton, malicious, in bad faith, deliberate, consciously wrongful, flagrant, or characteristic of a pirate.

543. To the extent applicable, the requirements of 35 U.S.C. § 287(a) have been met with respect to the ‘105 patent.

544. As a result of Amazon’s infringement of the ‘105 patent, Dynamic Data has suffered monetary damages, and seeks recovery in an amount adequate to compensate for

---

*Delivering Media & Entertainment using the AWS Cloud*, AWS TRANSFORMATION DAY GERMANY PRESENTATION (Oct. 25, 2017); *Fire TV Stick*, AMAZON USER GUIDE; *Watching Video in 4K Ultra HD on Fire TV*, AMAZON HELP WEBSITE, available at: <https://www.amazon.com/gp/help/customer/display.html?nodeId=201859000> (last visited Nov. 2018); *Amazon Fire TV*, AMAZON USER GUIDE; *Amazon Fire Tablet and Kindle E-Reader Quick Setup Guide*, AMAZON USER GUIDE (2014); *Fire & Kindle User’s Guides*, Amazon Help Website, available at: <https://www.amazon.com/gp/help/customer/display.html?nodeId=200317150> (last visited Nov. 2018).

Amazon's infringement, but in no event less than a reasonable royalty for the use made of the invention by Amazon together with interest and costs as fixed by the Court.

**PRAYER FOR RELIEF**

WHEREFORE, Dynamic Data respectfully requests that this Court enter:

- A. A judgment in favor of Dynamic Data that Amazon has infringed, either literally and/or under the doctrine of equivalents, the '073, '054A, '918, '689, '177, '112, '529, '230, '450, '944, '054B, '039, '227, and '105 patents;
- B. An award of damages resulting from Amazon's acts of infringement in accordance with 35 U.S.C. § 284;
- C. A judgment and order finding that Amazon's infringement was willful, wanton, malicious, bad-faith, deliberate, consciously wrongful, flagrant, or characteristic of a pirate within the meaning of 35 U.S.C. § 284 and awarding to Dynamic Data enhanced damages.
- D. A judgment and order finding that this is an exceptional case within the meaning of 35 U.S.C. § 285 and awarding to Dynamic Data its reasonable attorneys' fees against Amazon.
- E. Any and all other relief to which Dynamic Data may show themselves to be entitled.

**JURY TRIAL DEMANDED**

Pursuant to Rule 38 of the Federal Rules of Civil Procedure, Dynamic Data Technologies, LLC requests a trial by jury of any issues so triable by right.

Dated: February 4, 2019

Respectfully submitted,

/s/ Daniel P. Hipskind

Elizabeth L. DeRieux  
State Bar No. 05770585  
Capshaw DeRieux, LLP  
114 E. Commerce Ave.  
Gladewater, TX 75647  
Telephone: (903)235-2833  
Email: ederieux@capshawlaw.com

OF COUNSEL:

Dorian S. Berger (CA SB No. 264424)  
Daniel P. Hipskind (CA SB No. 266763)  
Eric B. Hanson (CA SB No. 254570)  
BERGER & HIPSKIND LLP  
9538 Brighton Way, Ste. 320  
Beverly Hills, CA 90210  
Telephone: 323-886-3430  
Facsimile: 323-978-5508  
E-mail: dsb@bergerhipskind.com  
E-mail: dph@bergerhipskind.com  
E-mail: ebh@bergerhipskind.com

*Attorneys for Dynamic Data  
Technologies, LLC*

**CERTIFICATE OF SERVICE**

I hereby certify that counsel of record who are deemed to have consented to electronic service are being served this 4th of February, 2019 with a copy of this document via the Court's CM/ECF System per Local Rule CV-5(a)(3). Any other counsel of record will be served by electronic mail, facsimile transmission and/or first class mail on this same date.

/s/ Daniel P. Hipskind  
Daniel P. Hipskind