

**IN THE UNITED STATES DISTRICT COURT
FOR THE DISTRICT OF NEBRASKA**

MIDWEST ATHLETICS AND SPORTS
ALLIANCE LLC

Plaintiff,

v.

RICOH USA, INC.

Defendant.

Case No.: 8:18-cv-00010-RFR-SMB

**FIRST AMENDED COMPLAINT FOR
PATENT INFRINGEMENT**

JURY TRIAL REQUESTED IN OMAHA

Plaintiff Midwest Athletics and Sports Alliance LLC (“MASA”) files this First Amended Complaint for Patent Infringement and Jury Demand against Defendant Ricoh USA, Inc. (“Defendant” or “Ricoh”) and alleges as follows:

THE PARTIES

1. MASA, a wholly-owned subsidiary of Midwest Youth A&S, Inc. (a Delaware public benefit corporation), is a Delaware limited liability corporation with its principal place of business at 1321 Jones Street, Suite 206, Omaha, NE 68102.

2. MASA provides services, funding and equipment for youth sports organizations to help those organizations inspire youths in a positive way and promotes the value and importance of sports and physical activity in the development of children. MASA believes in the principles of positive coaching and mentorship to not only ensure that each child learns the skills, tactics and strategies of the game but also learns the value of sportsmanship, problem-solving and leadership skills. MASA’s ultimate purpose is to see that every child has the ultimate sports experience and learns key life lessons that will be instrumental for them now and in the future.

3. Ricoh is an American corporation that sells document solutions and services, and

document technology products.

4. Ricoh is an Ohio corporation, with its principal place of business at 70 Valley Stream Parkway, Malvern, Pennsylvania. Ricoh's registered agent in Nebraska is C T Corporation System, 5601 South 59th Street, Lincoln, NE 68516.

JURISDICTION AND VENUE

5. This action arises under the Patent Act, 35 U.S.C. § 101 *et seq.* This Court has original jurisdiction over this controversy pursuant to 28 U.S.C. §§ 1331 and 1338.

6. This Court has personal jurisdiction over Defendant. Defendant does business in this District and has, and continues to, infringe MASA's patents (described below) in this District. In addition, the Court has personal jurisdiction over Defendant because Defendant has established minimum contacts with the forum and the exercise of jurisdiction would not offend traditional notions of fair play and substantial justice.

7. Venue is proper in this Court pursuant to 28 U.S.C. §§ 1391(b) and (c) and/or 1400(b).

8. Venue is proper because Ricoh has committed acts of patent infringement within the District and has a regular and established place of business located in the State of Nebraska.

9. Ricoh has committed acts of patent infringement in Nebraska, and throughout the United States, because it makes, uses, sells, offers for sale, and/or imports in Nebraska the Accused Products (identified below).

10. Ricoh has a regular and established place of business located in the State of Nebraska. For example, Ricoh maintains corporate offices and/or a place of business located at 8526 F Street., Suite 1, Omaha, NE 68127-1629; 300 N 44th Street, Suite 208, Lincoln, NE 68503-3415; 1616 N 203 Street, Elkhorn, NE 68022; and 1012 W 36th Street, Suite 2,

Scottsbluff, NE 69361. Furthermore, Ricoh's website indicates that it maintains a full service sales dealer at 8526 F Street, Omaha, NE 68127-1629 and at 300 N 44TH Street, Suite 208, Lincoln, NE 68503-3415:

1 **Omaha** A full service Sales Dealer.  [Find this location on the map](#)
8526 F Street
Omaha NE, 68127
Phone: (402) 331-6797
Fax: (402) 331-6380

2 **Lincoln** A full service Sales Dealer.  [Find this location on the map](#)
300 North 44th Street
Suite 208
Lincoln NE, 68503
Phone: (402) 488-8000
Fax: (402) 488-5566

Ex. 60 (PDF of <https://www.ricoh-usa.com/en/officelocator#dvResultSet>).

THE PATENTS-IN-SUIT

11. MASA owns the following United States Patents: 6,203,005, 6,305,684, 6,411,314, 6,462,756, 6,509,974, 6,554,269, 6,718,285, 6,724,998, 6,799,005, 6,993,278, 7,502,582, 7,658,375, 7,720,425, 8,005,415, 8,019,255, 8,220,795, 8,554,089, 8,591,022, and 8,805,239 (collectively referred to as the "MASA Patents").

12. On March 20, 2001, U.S. Patent No. 6,203,005 ("the '3005 Patent"), entitled FEEDER APPARATUS FOR DOCUMENTS AND THE LIKE, was issued to Tomasz K. Bednarek and Jose S. Pioquinto. A true and correct copy of the '3005 Patent is attached to this Complaint as Exhibit 1 and is incorporated by reference herein.

13. All rights, title, and interest in the '3005 Patent have been assigned to MASA, which is the sole owner of the '3005 Patent.

14. The '3005 Patent's abstract states that this patent is generally directed to a sheet feeder for engaging and removing a sheet of paper or other material from a stack and feeding it along a path. The sheet feeder can include a skimmer, a bumper, a separator, and a guide plate.

15. On October 23, 2001, U.S. Patent No. 6,305,684 ("the '684 Patent"), entitled FEED ROLLERS WITH REVERSING CLUTCH, was issued to Werner R. Lightner, Donald J. Stefanich, Jr., Jim T. Russo, Jose S. Pioquinto, and Paul E. Brodzik. A true and correct copy of the '684 Patent is attached to this Complaint as Exhibit 2 and is incorporated by reference herein.

16. All rights, title, and interest in the '684 Patent have been assigned to MASA, who is the sole owner of the '684 Patent.

17. The '684 Patent's abstract states that this patent is generally directed to a sheet feeder for engaging and removing a sheet of paper or other material from a stack and feeding it along a path. The sheet feeder can include a sheet separator designed for advancing the engaged sheet while retarding any adjacent sheets.

18. On June 25, 2002, U.S. Patent No. 6,411,314 ("the '314 Patent"), entitled SYSTEM AND METHOD FOR REPRESENTING AND CONTROLLING A PRODUCTION PRINTING WORKFLOW, was issued to David R. Hansen and Robert K. Holzwarth. A true and correct copy of the '314 Patent is attached to this Complaint as Exhibit 3 and is incorporated by reference herein.

19. All rights, title, and interest in the '314 Patent have been assigned to MASA, who is the sole owner of the '314 Patent.

20. The '314 Patent's abstract states that this patent is generally directed to a system and method for managing production printing workflow.

21. On October 8, 2002, U.S. Patent No. 6,462,756 ("the '756 Patent"), entitled

SYSTEM AND METHOD FOR VISUAL REPRESENTATION OF PAGES IN A PRODUCTION PRINTING WORKFLOW, was issued to David. R. Hansen and Robert K. Holzwarth. A true and correct copy of the '756 Patent is attached to this Complaint as Exhibit 4 and is incorporated by reference herein.

22. All rights, title, and interest in the '756 Patent have been assigned to MASA, who is the sole owner of the '756 Patent.

23. The '756 Patent's abstract states that this patent is generally directed to a system and method for managing production printing workflow. The system includes workflow management software which manages and facilitates the procedural stages of the workflow including job origination, job preparation, job submission and job fulfillment.

24. On January 21, 2003, U.S. Patent No. 6,509,974 ("the '974 Patent"), entitled AUTOMATED JOB CREATION FOR JOB PREPARATION, was issued to David R. Hansen. A true and correct copy of the '974 Patent is attached to this Complaint as Exhibit 5 and is incorporated by reference herein.

25. All rights, title, and interest in the '974 Patent have been assigned to MASA, who is the sole owner of the '974 Patent.

26. The '974 Patent's abstract states that this patent is generally directed to a system and method for providing production printing instructions for a printed end document to a job preparation station.

27. On April 29, 2003, U.S. Patent No. 6,554,269 ("the '269 Patent"), entitled AIRKNIFE AND VACUUM CONTROL CHANGES TO IMPROVE SHEET ACQUISITION FOR A VACUUM CORRUGATED FEED SUPPLY, was issued to Michael T. Dobbertin and Thomas K. Scieurba. A true and correct copy of the '269 Patent is attached to this Complaint as

Exhibit 6 and is incorporated by reference herein.

28. All rights, title, and interest in the '269 Patent have been assigned to MASA, which is the sole owner of the '269 Patent.

29. The '269 Patent's abstract states that this patent is generally directed to a method of operating a vacuum corrugated belt feeder, which may or may not have a positive air pressure separator, during non-feed cycle time.

30. On April 6, 2004, U.S. Patent No. 6,718,285 ("the '285 Patent"), entitled OPERATOR REPLACEABLE COMPONENT LIFE TRACKING SYSTEM, was issued to Thomas Leonard Schwartz, Richard Robert Tilney Carling, and Kenneth Thomas Doty. A true and correct copy of the '285 Patent is attached to this Complaint as Exhibit 7 and is incorporated by reference herein.

31. All rights, title, and interest in the '285 Patent have been assigned to MASA, who is the sole owner of the '285 Patent.

32. The '285 Patent's abstract states that this patent is generally directed to operator replaceable component devices that enable an operator that is not a skilled field engineer or service technician, to perform maintenance on a digital printing system, resulting in significantly higher uptime for the press.

33. On April 20, 2004, U.S. Patent No. 6,724,998 ("the '998 Patent"), entitled IMAGE FORMING APPARATUS WITH VARIABLE TONING BIAS OFFSET SERVICE UTILITY, was issued to Matthias Regelsberger, David Hockey and Anna Lairmore. A true and correct copy of the '998 Patent is attached to this Complaint as Exhibit 8 and is incorporated by reference herein.

34. All rights, title, and interest in the '998 Patent have been assigned to MASA, who is the sole owner of the '998 Patent.

35. The '998 Patent's abstract states that this patent is generally directed towards an electrographic print engine that has a variable primary charger and toning bias which places the machine in abnormal reproduction modes in order to provide service and diagnostic information to troubleshoot subsystems involved in the electrographic process.

36. On September 28, 2004, U.S. Patent No. 6,799,005 ("the '9005 Patent"), entitled METHOD AND SYSTEM OF PRE-SELECTING ORDERED MEDIA IN A PRINTING SYSTEMS, was issued to James E. Bodine and Thomas R. Hull. A true and correct copy of the '9005 Patent is attached to this Complaint as Exhibit 9 and is incorporated by reference herein.

37. All rights, title, and interest in the '9005 Patent have been assigned to MASA, who is the sole owner of the '9005 Patent.

38. The '9005 Patent's abstract states that this patent is generally directed to a method of pre-selecting ordered media in a printing system, wherein ordered media, such as tabs, are pre-selected into a part for use in a print run and an unwanted part to be discarded.

39. On January 31, 2006, U.S. Patent No. 6,993,278 ("the '278 Patent"), entitled FIXING DEVICE TRANSPORT FOR A DIGITAL PRINTER OR COPIER MACHINE, was issued to Gerhard Bartscher, Frank-Michael Morgenweck, Kai-Uwe Preissig, Domingo Rohde, Detlet Schulze-Hagenest, Ralf Gerald Allner, Thomas Biber, and Markus Weber. A true and correct copy of the '278 Patent is attached to this Complaint as Exhibit 10 and is incorporated by reference herein.

40. All rights, title, and interest in the '278 Patent have been assigned to MASA, who is the sole owner of the '278 Patent.

41. The '278 Patent's abstract states that this patent is generally directed towards a digital printer or copier machine proposed for the single-sided or double-sided printing of a substrate, with at least one fixing device for fixing toner onto the substrate, whereby the fixing device has at least one heating device for fusing the toner.

42. On March 10, 2009, U.S. Patent No. 7,502,582 ("the '582 Patent"), entitled METHOD AND APPARATUS FOR PRINTING USING A TANDEM ELECTROSTATOGRAPHIC PRINTER, was issued to Yee S. Ng and Robert C. Logel. A true and correct copy of the '582 Patent is attached to this Complaint as Exhibit 11 and is incorporated by reference herein.

43. All rights, title, and interest in the '582 Patent have been assigned to MASA, who is the sole owner of the '582 Patent.

44. The '582 Patent's abstract states that this patent is generally directed towards a tandem color electrostatographic printer apparatus having five or more color printing stations or modules for applying respective color separation toner images to a receiver member to form a pentachrome color image in a single pass.

45. On Feb. 9, 2010, U.S. Patent No. 7,658,375 ("the '375 Patent"), entitled PRINTER AND DUAL TRAYS FOR IMAGE RECEIVER MEDIA SHEETS, was issued to Randal M. Wong, Juan Belon, and Petrica D. Balcan. A true and correct copy of the '375 Patent is attached to this Complaint as Exhibit 12 and is incorporated by reference herein.

46. All rights, title, and interest in the '375 Patent have been assigned to MASA, who is the sole owner of the '375 Patent.

47. The '375 Patent's abstract states that this patent is generally directed towards a printer having a sheet tray, a driver for advancing sheets past a marking mechanism, and a picker

to remove sheets from an aligned tray including a load position and a pick position.

48. On May 18, 2010, U.S. Patent No. 7,720,425 (“the ‘425 Patent”), entitled METHOD AND APPARATUS FOR PRINTING USE A TANDEM ELECTROSTATOGRAPHIC PRINTER, was issued to Yee S. Ng and Robert C. Logel. A true and correct copy of the ‘425 Patent is attached to this Complaint as Exhibit 13 and is incorporated by reference herein.

49. All rights, title, and interest in the ‘425 Patent have been assigned to MASA, who is the sole owner of the ‘425 Patent.

50. The ‘425 Patent’s abstract states that this patent is generally directed towards a tandem color electrostatographic printer apparatus having five or more color printing stations or modules for applying respective color separation toner images to a receiver member to form a pentachrome color image in a single pass.

51. On Aug. 23, 2011, U.S. Patent No. 8,005,415 (“the ‘415 Patent”), entitled METHOD AND APPARATUS FOR PRINTING USE A TANDEM ELECTROSTATOGRAPHIC PRINTER, was issued to Yee S. Ng and Robert C. Logel. A true and correct copy of the ‘415 Patent is attached to this Complaint as Exhibit 14 and is incorporated by reference herein.

52. All rights, title, and interest in the ‘415 Patent have been assigned to MASA, who is the sole owner of the ‘415 Patent.

53. The ‘415 Patent’s abstract states that this patent is generally directed towards a tandem color electrostatographic printer apparatus having five or more color printing stations or modules for applying respective color separation toner images to a receiver member to form a pentachrome color image in a single pass.

54. On Sept. 12, 2011, U.S. Patent No. 8,019,255 (“the ‘255 Patent”), entitled ALIGNMENT METHOD FOR A PLURALITY OF COUPLED DIGITAL PRINT ENGINES, was issued to Michael T. Dobbertin and Alan E. Rapkin. A true and correct copy of the ‘255 Patent is attached to this Complaint as Exhibit 15 and is incorporated by reference herein.

55. All rights, title, and interest in the ‘255 Patent have been assigned to MASA, who is the sole owner of the ‘255 Patent.

56. The ‘255 Patent’s abstract states that this patent is generally directed towards an adjustment method to align printing engines in a print assembly that is capable of printing on a receiver to form one or more final prints and includes corrections for cross-track misregistration.

57. On July 17, 2012, U.S. Patent No. 8,220,795 (“the ‘795 Patent”), entitled PRINTER AND DUAL TRAYS FOR IMAGE RECEIVER MEDIA SHEETS, was issued to Randal M. Wong, Juan Belon, and Petrica D. Balcan. A true and correct copy of the ‘795 Patent is attached to this Complaint as Exhibit 16 and is incorporated by reference herein.

58. All rights, title, and interest in the ‘795 Patent have been assigned to MASA, who is the sole owner of the ‘795 Patent.

59. The ‘795 Patent’s abstract states that this patent is generally directed towards a printer having a sheet tray, a drive for advancing sheets past a marking mechanism, and a picker to remove sheets from an aligned tray.

60. On Oct. 8, 2013, U.S. Patent No. 8,554,089 (“the ‘089 Patent”), entitled JOB ERROR CORRECTION IN A MULTICOLOR ELECTROPHOTOGRAPHIC PRINT ENGINE, was issued to James D. Shifley, Alan J. Swire, and Thomas N. Tombs. A true and correct copy of the ‘089 Patent is attached to this Complaint as Exhibit 17 and is incorporated by reference herein.

61. All rights, title, and interest in the '089 Patent have been assigned to MASA, who is the sole owner of the '089 Patent.

62. The '089 Patent's abstract states that this patent is generally directed towards a method and system for printing image documents using a variety of toners where some toners use a multi-development station having two or more development stations. These toners are co-printed prior to fixing on the receiver by the multi-development station.

63. On Nov. 26, 2013, U.S. Patent No. 8,591,022 ("the '022 Patent"), entitled PRINTING APPARATUS WITH PIVOTABLE DUPLEXING UNIT, was issued to Slew Pern Chuang, Richard A. Murray, Venkatesh Mysore Nagaraja Rao, and Keng Leong Ng. A true and correct copy of the '022 Patent is attached to this Complaint as Exhibit 18 and is incorporated by reference herein.

64. All rights, title, and interest in the '022 Patent have been assigned to MASA, who is the sole owner of the '022 Patent.

65. The '022 Patent's abstract states that this patent is generally directed towards a pivotable duplexing unit attached to the wall of a printer using a hinge having an axis that is substantially perpendicular to the base.

66. On Aug. 12, 2014, U.S. Patent No. 8,805,239 ("the '239 Patent"), entitled ACTUATION DEVICE FOR PRESSURE ROLLERS, was issued to Lennardt Jader and Peter Schmidt. A true and correct copy of the '239 Patent is attached to this Complaint as Exhibit 19 and is incorporated by reference herein.

67. All rights, title, and interest in the '239 Patent have been assigned to MASA, who is the sole owner of the '239 Patent.

68. The '239 Patent's abstract states that this patent is generally directed towards a device for moving a plurality of pressure rollers relative to respective counter rollers in a printing machine, wherein, in a non-energy mode, the pressure rollers are arranged in a non-contact position.

THE ACCUSED PRODUCTS

69. Ricoh makes, uses, sells, offers for sale, and/or imports into the United States and this District a variety of office equipment, including printers, scanners, and/or multifunction systems that include functionality such as printing, scanning and copying (the "Ricoh Office Equipment").

70. The Ricoh Office Equipment includes a variety of models, including those referred to as Aficio MP, Aficio SP, and Pro (the "Ricoh Printer Models"). Ricoh makes, uses, sells, offers for sale, and/or imports into the United States and this District the Ricoh Office Equipment, including the Ricoh Printer Models.

71. A depiction of an Aficio MP printer is provided below:



Ex. 20 (PDF of

http://www2.ricoh-usa.com/products/docs/pdf/brochures/multifunction_bw/aficiomp5002.pdf).

72. Various models of the Aficio MP printers (e.g., MP 4002/4002SP/5002/5002SP, Ricoh MP 2555/3055/3555/4055/5055/6055 and C2030, C2050, C2530, C2550) use one or more of the MASA Patents.

73. A depiction of an Aficio SP printer is provided below:



Ex. 21 (PDF of <https://www.ricoh-usa.com/-/media/Ricoh/Common/PDFs/Brochures/aficiospc830dn.pdf>).

74. Various models of the Aficio SP printers (e.g., Ricoh Aficio SP C830DN, C831DN) use one or more of the MASA Patents.

75. A depiction of a Pro printer (e.g., Ricoh Pro C7100/C7100x/C7110/C7110x) is provided below:



Ex. 22 (PDF of <https://www.ricoh-usa.com/->

[/media/ricoh/common/pdfs/brochures/proc7100.pdf?tm=20171205T170018Z](https://www.ricoh-usa.com/-/media/ricoh/common/pdfs/brochures/proc7100.pdf?tm=20171205T170018Z)).

76. Various models of the Pro printers (e.g., Ricoh Pro C7100/C7100x/C7110/C7110x) use one or more of the MASA Patents.

77. Ricoh also makes, uses, sells, offers for sale, and/or imports into the United States and this District its Ricoh TotalFlow suite of software programs (e.g., TotalFlow Prep, TotalFlow Production Manager, and TotalFlow Print Server) (collectively “Ricoh TotalFlow”) and Ricoh ProcessDirector.

78. Ricoh TotalFlow and Ricoh ProcessDirector are compatible with a wide variety of Ricoh’s multifunction units, digital presses, production printers and copiers, and continuous feed printers, including at least the Pro printers.

79. Ricoh TotalFlow suite of software and Ricoh ProcessDirector system use one or more of the MASA patents.

80. Ricoh also makes, uses, sells, offers for sale, and/or imports into the United States and this District its Ricoh Preventative Maintenance (PM) and Trained Customer Replacement Units (TCRU).

81. The Ricoh Preventative Maintenance (PM) and Trained Customer Replacement Units (TCRU) are compatible with Ricoh's production printers. Ex. 23 (PDF of <https://www.rioh-usa.com/en/services-and-solutions/commercial-industrial-printing-services/printer-maintenance-services-printer-support>).

82. Ricoh's Ricoh Preventative Maintenance (PM) and Trained Customer Replacement Units (TCRU) use one or more of the MASA patents.

COUNT I

(Direct Infringement of the '3005 Patent pursuant to 35 U.S.C. § 271(a))

83. MASA repeats, realleges, and incorporates by reference, as if fully set forth herein, the allegations of the preceding paragraphs, as set forth above.

84. Defendant has infringed and continues to infringe one or more claims of the '3005 Patent, including at least claim 1 in violation of 35 U.S.C. § 271(a).

85. Defendant's infringement is based upon literal infringement or infringement under the doctrine of equivalents, or both.

86. Defendant's acts of making, using, importing, selling, and/or offering for sale infringing products and services have been without the permission, consent, authorization, or license of MASA.

87. Defendant's infringement includes the manufacture, use, sale, importation and/or offer for sale of Defendant's products and services, such as Ricoh MP 4002/4002SP/5002/5002SP, Ricoh MP 2555/3055/3555/4055/5055/6055 and Ricoh Aficio MP C2030, C2050, C2530, C2550.

88. Claim 1 of the '3005 Patent is recited below:

A sheet feeder comprising:

1[a] a skimmer for engaging and removing a sheet from one end of a stack of sheets and feeding the engaged sheet edgewise along a feed path, said skimmer comprising a first friction element including a generally cylindrical endless rotating peripheral surface carried on a support defined at least in part by a rotating shaft;

1[b] a separator spaced downstream along the feed path from the skimmer for advancing the engaged sheet while retarding any adjacent sheets; and

1[c] a first guide plate extending between said skimmer and said separator substantially parallel to said feed path to guide the engaged single sheet substantially along the feed path, preventing buckling of the engaged single sheet perpendicular to the feed path,

1[d] wherein said first guide plate is supported at least in part by and mounted to be pivotable independent of the rotation of said rotating shaft with respect to said support.

89. As one example of how the '3005 Accused Products infringe at least claim 1, Ricoh Aficio MP 2555 meets the limitations of claim 1 of the '3005 Patent for at least the reasons described below.

90. An image of the Aficio MP 2555 is provided below:



91. In general and as explained below, the limitations of claim 1 are satisfied because the Aficio MP 2555 is a multifunction printer that includes a sheet feeder. The sheet feeder in the Aficio MP 2555, as shown below, includes a sheet feeder (referred to as a “paper

feed unit) that includes a roller holder, a pick-up roller, a feed roller, a separation roller, and a torque limiter:

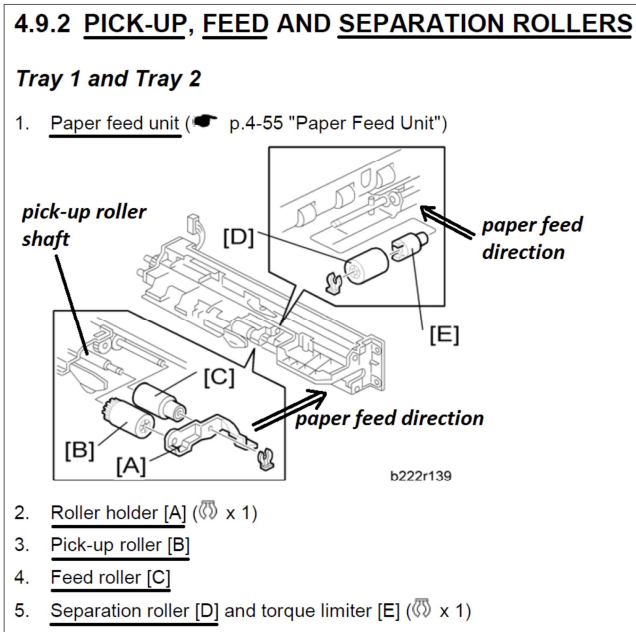

Ex. 24 (D129/D130 Service Manual (2012)).

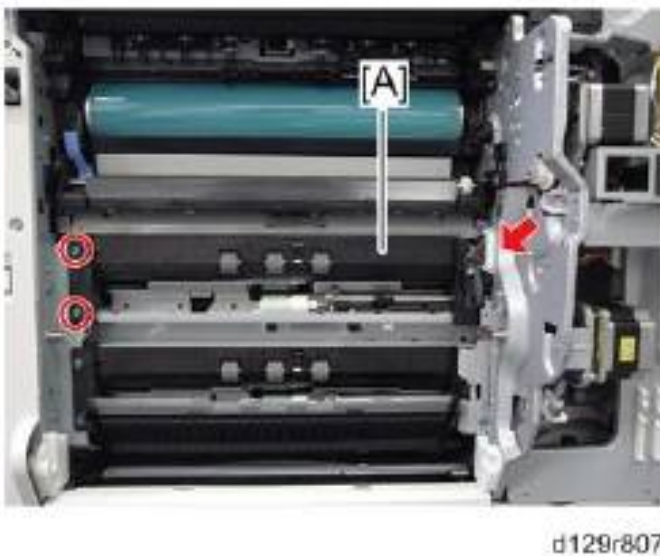

6. Paper feed unit [A] (☞ x 2, ☞ x 1)

Ex. 24 (D129/D130 Service Manual (2012)).

2.2.3 PICK-UP AND SEPARATION

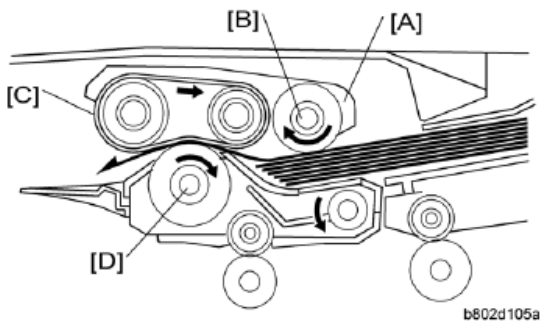

The original is set with the image facing up. The original pushes actuator and the original set sensor is activated.

After pressing the start button, the pick-up motor is activated and the original feed unit [A] moves down. At the same time, the ADF feed motor is activated and the pick-up roller [B] feeds original to the feed belt [C].

After being fed from feed belt [C], the topmost sheet is separated from the stack by the separation roller [D] and sent to the skew correction roller.

The mechanism is an FRR system, consisting of the original feed belt [C] and separation roller [D].

Ex. 24 (D129/D130 Service Manual).

92. Claim limitation 1[a] is satisfied for at least the following reasons. As shown below, the Aficio MP 2555 includes a skimmer (e.g., pick-up roller, feed roller, or separation roller) that engages and removes sheets of paper from a stack of papers and feeds the picked-up paper edgewise along a feed path (see “paper feed direction”). The skimmer further includes a cylindrical friction element carried on a support (see roller holder) defined by a rotating shaft:

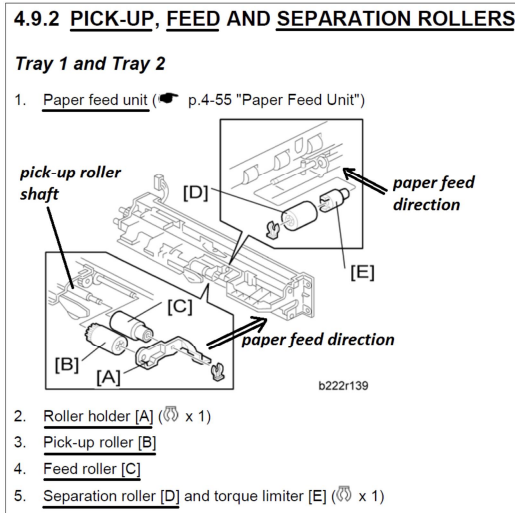

Ex. 24 (D129/D130 Service Manual (2012)).

93. In addition, as shown below, pick-up roller [B] is a skimmer for engaging a piece of paper on a stack of papers and the skimmer rotates and removes a sheet from one end of the stack of sheets and feeds the sheet along a feed path:

2.2.3 PICK-UP AND SEPARATION

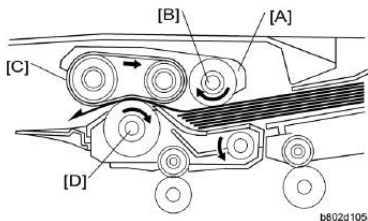

The original is set with the image facing up. The original pushes actuator and the original set sensor is activated.

After pressing the start button, the pick-up motor is activated and the original feed unit [A] moves down. At the same time, the ADF feed motor is activated and the pick-up roller [B] feeds original to the feed belt [C].

After being fed from feed belt [C], the topmost sheet is separated from the stack by the separation roller [D] and sent to the skew correction roller.

The mechanism is an FRR system, consisting of the original feed belt [C] and separation roller [D].

Ex. 24 (D129/D130 Service Manual).

94. Claim limitation 1[b] is satisfied for at least the following reasons. As shown below, because the sheet feeder of the Aficio MP 2555 includes a separator (e.g., separation roller [D]) located downstream from the skimmer whereby the separator advances a feed sheet along the feed path while retarding any adjacent sheets:

4.9.2 PICK-UP, FEED AND SEPARATION ROLLERS

Tray 1 and Tray 2

1. Paper feed unit (☞ p.4-55 "Paper Feed Unit")

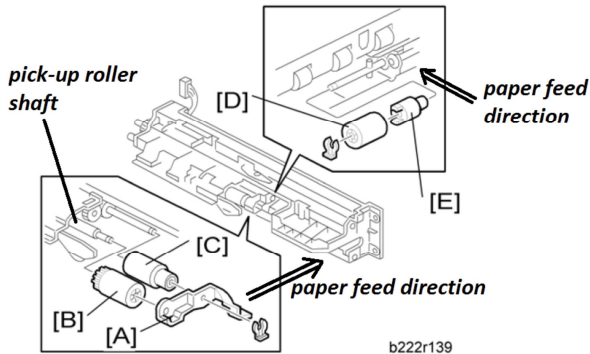

2. Roller holder [A] (☞ x 1)
3. Pick-up roller [B]
4. Feed roller [C]
5. Separation roller [D] and torque limiter [E] (☞ x 1)

Ex. 24 (D129/D130 Service Manual (2012), page 4-56).

95. In addition, as shown below and explained in Ricoh documentation, “the topmost sheet is separated from the stack by the separation roller [D]”:

2.2.3 PICK-UP AND SEPARATION

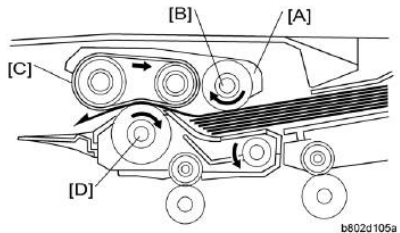

The original is set with the image facing up. The original pushes actuator and the original set sensor is activated.
 After pressing the start button, the pick-up motor is activated and the original feed unit [A] moves down. At the same time, the ADF feed motor is activated and the pick-up roller [B] feeds original to the feed belt [C].
 After being fed from feed belt [C], the topmost sheet is separated from the stack by the separation roller [D] and sent to the skew correction roller.
 The mechanism is an FRR system, consisting of the original feed belt [C] and separation roller [D].

Ex. 24 (D129/D130 Service Manual, p.955).

96. Claim limitation 1[c] is satisfied for at least the following reasons. As shown below, the Aficio MP 2555 includes a first guide plate (represented by Guide pate [c]) that extends between the skimmer and the separator and is substantially parallel to the feed path to

guide the engaged single sheet substantially along the feed path, preventing buckling of the engaged single sheet perpendicular to the feed path:

2.2.3 PICK-UP AND SEPARATION

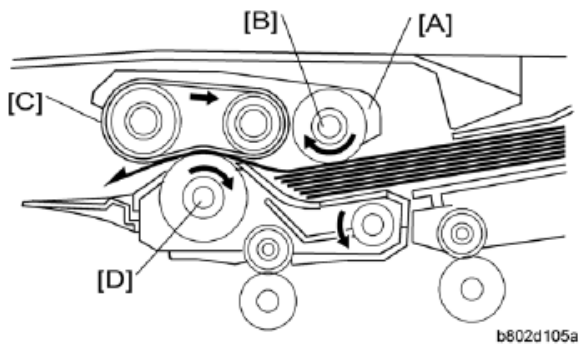

Ex. 24 (D129/D130 Service Manual).

3.1 PAPER FEED UNIT

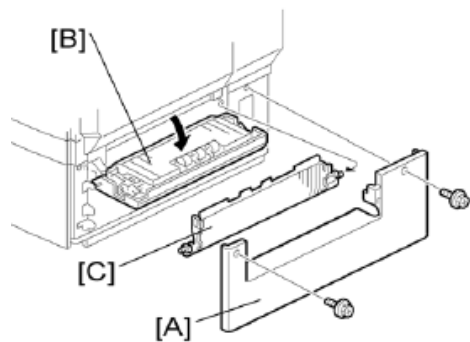

- Right cover [A]
- Open the vertical guide plate [B]
- Guide plate [C]

Ex. 24 (D129/D130 Service Manual, p.998).

97. In addition, in the Aficio MP2555, a first guide plate (left guide) runs parallel to the feed path and extends between the skimmer and the separator. The left guide plate and a second guide plate (the right guide plate) each engage a single sheet of paper to prevent the sheet from buckling perpendicular to the feed path.

041	Bridge/Exit Tray: Left Guide Open/Close	Close	Open
042	Bridge/Exit Tray: Right Guide Open/Close	Close	Open

Ex. X (D129/D130 Service Manual (2012), page 444).

98. Furthermore, the Aficio MP2555 includes a “feed-in guide plate” [B] extending between the skimmer and the separator and running parallel to the guide path to engage a sheet and prevent the sheet from buckling.

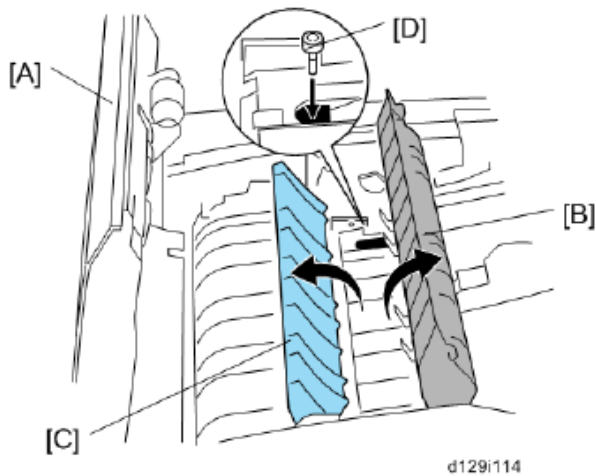

13. Open the ARDF cover [A].

14. Open the feed-in guide plate [B] and feed-out guide plate [C].

Ex. 24 (D129/D130 Service Manual, p.64).

99. Moreover, the first guide plate of the Aficio MP 2255 extends between the skimmer [B] and [C] and the separator [D] and is substantially parallel to the feed path (see “paper feed direction”) whereby the feed path guides the paper sheet along the feed path preventing buckling of the engaged single sheet perpendicular to the feed path (see “paper feed direction”) as shown in the images below:

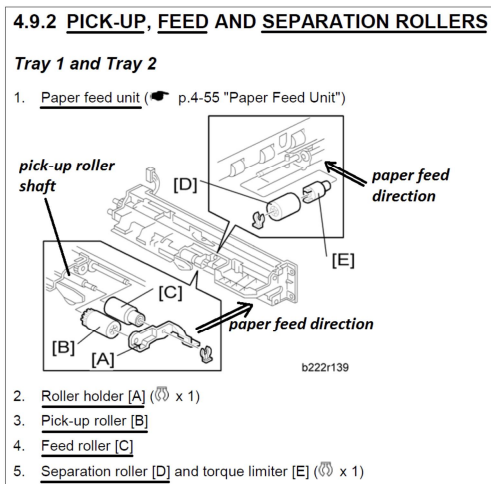

Ex. 24 (D129/D130 Service Manual (2012), page 4-56).

2.2.3 PICK-UP AND SEPARATION

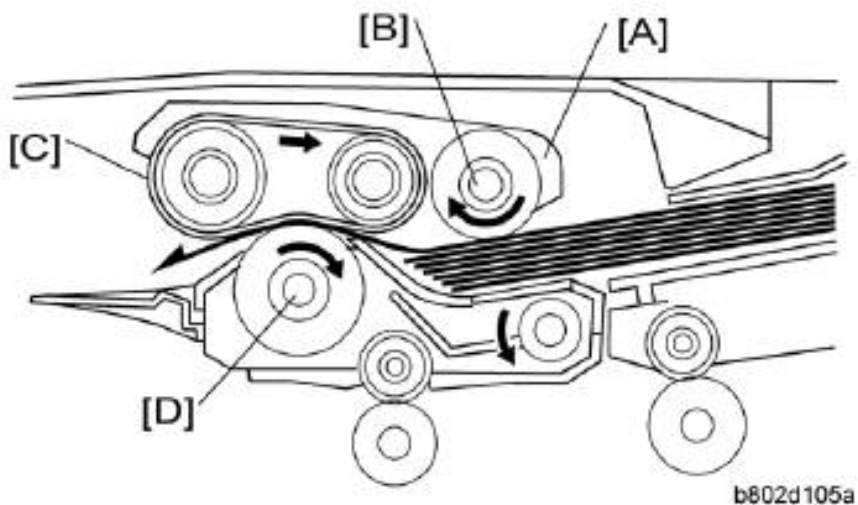

Ex. 24 (D129/D130 Service Manual, p.955).

100. Claim limitation 1[d] is satisfied for at least the following reasons. As shown below, the Aficio MP 2255 includes a paper guide plate that is mounted on hooks to be pivotable independent of the rotation of the rotating shaft with respect to the support:



Paper guide plate [A] (hook x 2)

Ex. 24 (D129/D130 Service Manual (2012), p.195).

101. In addition, the Aficio MP2225 includes a “feed-in guide plate” [B] mounted to be pivotable (along the arrow shown in the image below):

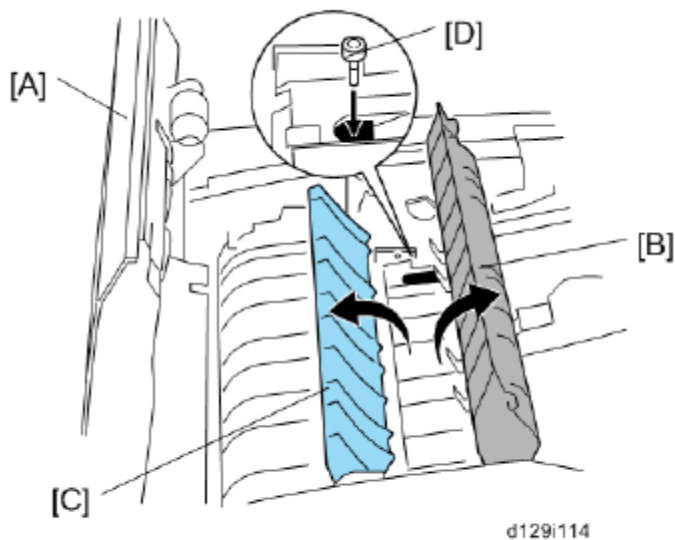

13. Open the ARDF cover [A].

14. Open the feed-in guide plate [B] and feed-out guide plate [C].

Ex. 24 (D129/D130 Service Manual, p.64).

102. Furthermore, as shown in the image below, the roller holder [A] of the skimmer (e.g., pick-up roller, feed roller, or separation roller) in the Aficio MP 2225 is supported by and

mounted to the shaft of the pick-up roller (e.g., the component labeled 'pickup-roller shaft' in the diagram) in a manner that allows it to be pivotable with respect to the shaft independent of rotation of the shaft:

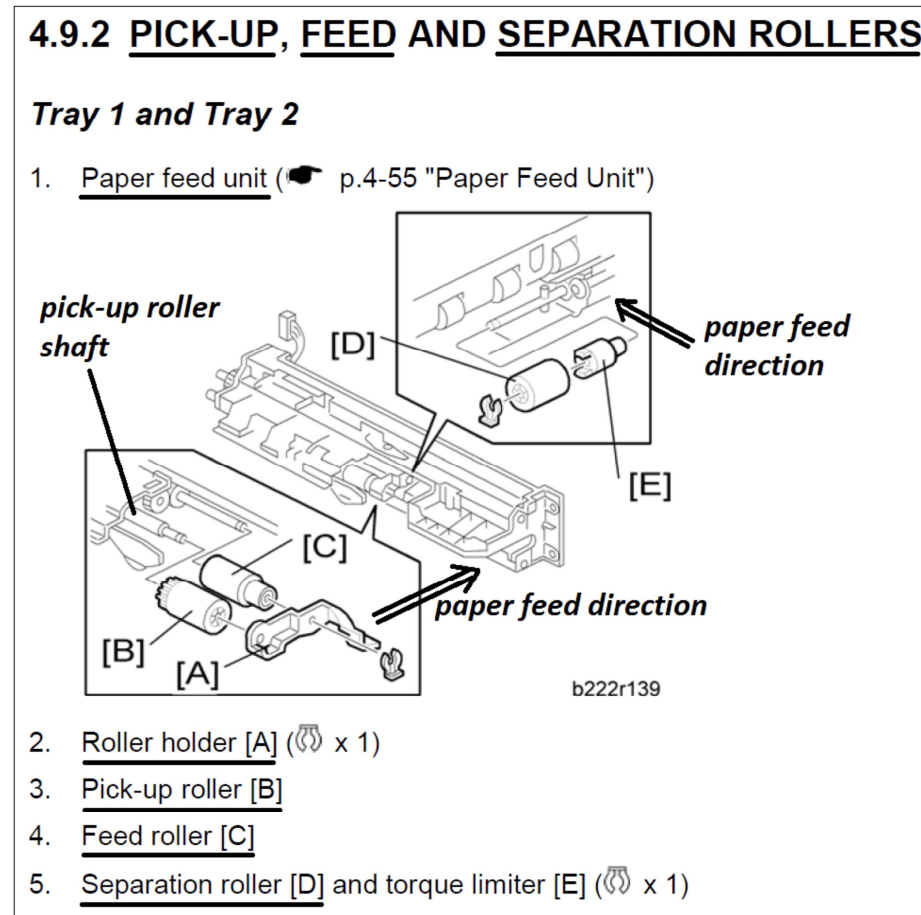

Ex. 24 (D129/D130 Service Manual (2012), p.196).

103. Ricoh also infringes under the doctrine of equivalents because it meets at least, and by way of example, the following claim limitation(s) of representative Claim 1 by performing substantially the same function as this limitation, performing this function in substantially the same way as this limitation, and achieving substantially the same results as claim limitation 1[c]. For example, and without limitation, Aficio MP 2225 perform substantially the same function in substantially the same way and achieves substantially the

same result at least because they comprise a guiding surface that runs along the path where the paper sheets are fed into the sheet feeder. This guiding surface performs the same function of guiding the paper along the sheet path, in the same way, to achieve the same result of feeding sheets of paper into the sheet feeder.

104. As a result of Defendant's unlawful activities, MASA has suffered and will continue to suffer irreparable harm for which there is no adequate remedy at law. Accordingly, MASA is entitled to preliminary and/or permanent injunctive relief.

105. Defendant's infringement of the '3005 Patent has injured and continues to injure MASA in an amount to be proven at trial.

COUNT II

(Direct Infringement of the '684 Patent pursuant to 35 U.S.C. § 271(a))

106. MASA repeats, realleges, and incorporates by reference, as if fully set forth herein, the allegations of the preceding paragraphs, as set forth above.

107. Defendant has infringed and continues to infringe one or more claims of the '684 Patent, including at least claim 1, in violation of 35 U.S.C. § 271(a).

108. Defendant's infringement is based upon literal infringement or infringement under the doctrine of equivalents, or both.

109. Defendant's acts of making, using, importing, selling, and/or offering for sale infringing products and services have been without the permission, consent, authorization, or license of MASA.

110. Defendant's infringement includes the manufacture, sale, importation and/or offer for sale of Defendant's products and services, such as Ricoh Aficio MP C2030, C2050, C2530, C2550, and similar printers.

111. Claim 1 of the '684 Patent is recited below:

A sheet separator, comprising:

1[a] a sheet path along which a sheet having a first and second surfaces is passed;

1[b] an advancing roller positioned to drive forward the first surface of a sheet in said sheet path;

1[c] a retarding roller positioned to drive the second surface of a sheet in said sheet path;

1[d] a drive for driving said retarding roller backward;

1[e] a roller shaft on which said retarding roller is mounted in fixed relation, said roller shaft extending axially from said retarding roller;

1[f] a friction clutch spaced from said retarding roller and connecting said drive with said roller shaft;

1[g]. said clutch permitting said retarding roller to be driven forward when fewer than two sheets are engaged between said advancing and retarding rollers, and

1[h]. said clutch permitting said retarding roller to be driven backward when two or more sheets are engaged by said advancing and retarding rollers.

112. As one example of how the '684 Accused Products infringe at least claim 1, Ricoh Aficio MP C2030 meets the limitations of claim 1 of the '684 Patent for at least the reasons described below.

113. An image of Ricoh Aficio MP C2030 is provided below:



114. As a general matter and as explained below, the limitations of claim 1 are satisfied because the Ricoh Aficio MP C2030 is a multifunction printer that includes “a sheet separator” and encompasses a “two-tray paper unit” and “one-tray paper feed units.”

115. The sheet separator further includes a separation mechanism or a friction pad. As shown below, “the paper feed roller [A] drives the top sheet of paper from the paper tray to the copier/printer. The friction pad [B] allows only one sheet to feed at a time. The friction pad applies pressure to the feed roller with a spring [C].”

Paper Feed and Separation Mechanism

2.2 PAPER FEED AND SEPARATION MECHANISM

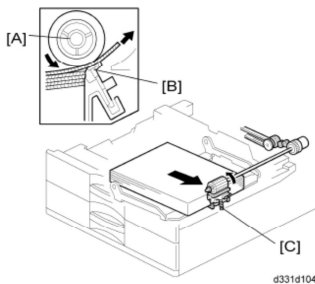

The paper tray holds 500 sheets. The paper feed roller [A] drives the top sheet of paper from the paper tray to the copier/printer. The friction pad [B] allows only one sheet to feed at a time. The friction pad applies pressure to the feed roller with a spring [C].

Ex. 25 (C2030-C2550 Service manual.pdf).

116. The sheet separator further comprise separation roller [1] which is a sheet separator designed for advancing the engaged sheet while retarding any adjacent sheets as shown below.

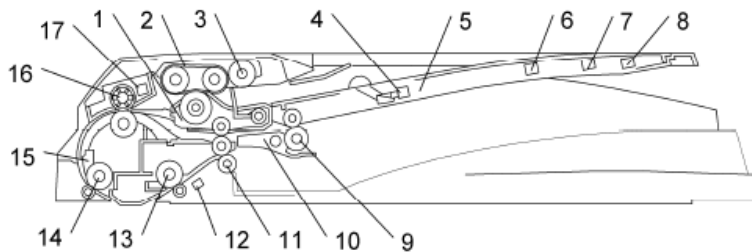

1. Separation Roller	10. Junction Gate
2. Paper Feed Belt	11. Exit Roller
3. Pick-up Roller	12. Original Exit Sensor

Ex. 25 (C2030-C2550 Service manual.pdf).

117. Claim limitation 1[a] is satisfied for at least the following reasons. As shown below, Ricoh Aficio MP C2030 includes a sheet path for a sheet of paper that includes a first and second surface that travels through during printing. “The feed and transport motors feed the original through the scanning area” and then “the original is fed out by the transport roller and exit roller” along the arrow in the images provided below:

2.2.5 ORIGINAL TRANSPORT AND EXIT

Single-Sided Originals

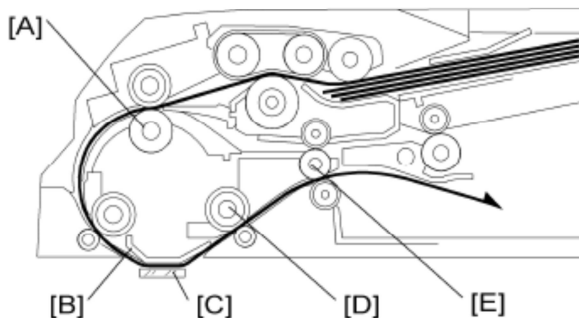

The feed motor feeds the separated original to the skew correction roller [A] at maximum speed. After skew correction, the feed and transport motors feed the original through the scanning area at a lower speed (the scanning area contains the original exposure guide [B] and DF exposure glass [C]). After scanning, the original is fed out by the transport roller [D] and exit roller [E].

Double-Sided Originals

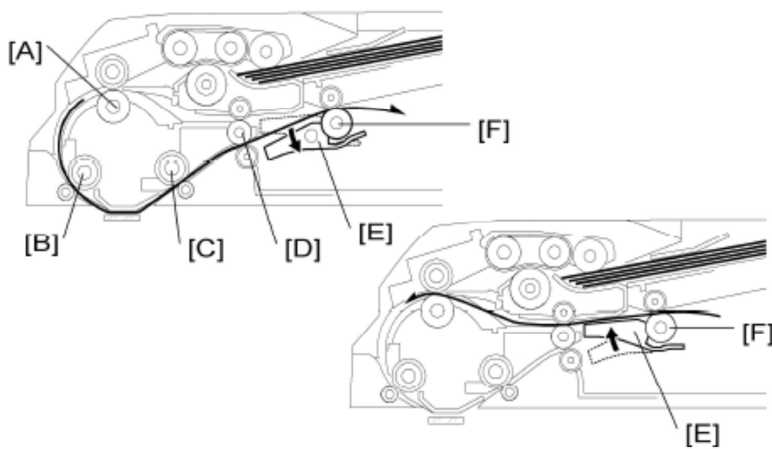

After skew correction, the feed and transport motors drive the skew correction roller [A], registration roller [B], transport roller [C] and the exit roller [D]. The front side of the original is then scanned.

When the original exit sensor detects the leading edge of the original, the junction gate solenoid is activated and the junction gate [E] opens. The original is then transported

Ex. 25 (C2030-C2550 Service manual.pdf, p.954).

Paper Feed and Separation Mechanism

2.2 PAPER FEED AND SEPARATION MECHANISM

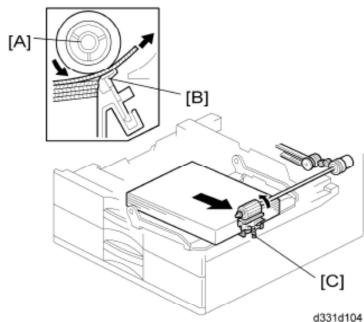

The paper tray holds 500 sheets. The paper feed roller [A] drives the top sheet of paper from the paper tray to the copier/printer. The friction pad [B] allows only one sheet to feed at a time. The friction pad applies pressure to the feed roller with a spring [C].

Ex. 25 (C2030-C2550 Service manual.pdf, p.918).

2.1.2 PAPER PATH

With options

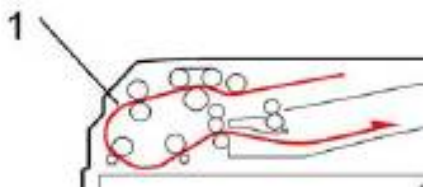

Ex. 25 (C2030-C2550 Service manual.pdf, p.410).

118. Claim limitation 1[b] is satisfied for at least the following reasons. As shown below, the Ricoh Aficio MP C2030 includes an advancing roller positioned to drive forward the first surface of a sheet.

119. For example, the pick-up roller [B] in the image below is an advancing roller that drives forward the sheet as the sheet moves past Separation Roller [D]. By way of further example, feed unit [A], consisting of pick-up roller [B] and feed belt [C] is an advancing roller

positioned to drive forward the sheet along the sheet path as the sheet moves past Separation Roller [D].

Basic Operation

2.2.3 PICK-UP AND SEPARATION

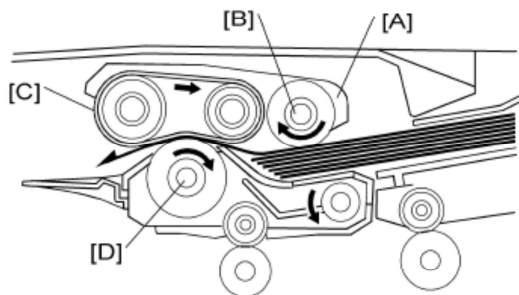

The original is set with the image facing up. The original pushes actuator and the original set sensor is activated.

After pressing the start button, the feed clutch is activated and the original feed unit [A] moves down. At the same time, the pick-up solenoid is activated and the original table lifts until the original comes in contact with the pick-up roller [B]. The pick-up roller then feeds the top sheet of paper.

After being fed from feed belt [C], the topmost sheet is separated from the stack by the separation roller [D] and sent to the skew correction roller.

The mechanism is an FRR system, consisting of the original feed belt [C] and separation roller [D].

Ex. 25 (C2030-C2550 Service manual.pdf , p.952).

120. By way of additional example, paper feed belt [2] and pick-up roller [3] shown in the image below act as advancing rollers to drive sheet of paper forward. After being fed from feed belt, the top most sheet is separated from the stack of sheets through the separation mechanism shown below:

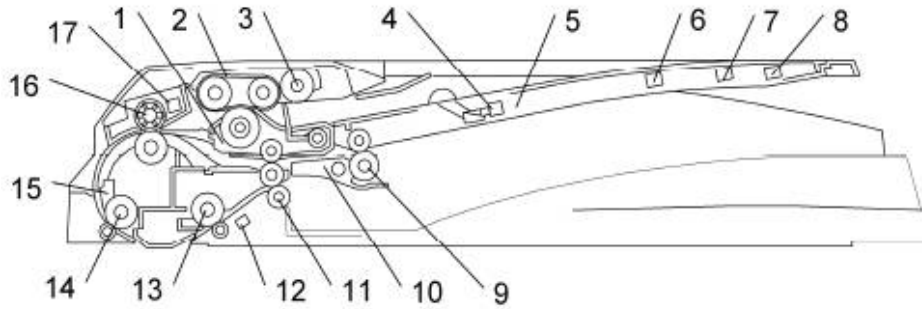

- | | |
|----------------------|--------------------------|
| 1. Separation Roller | 10. Junction Gate |
| 2. Paper Feed Belt | 11. Exit Roller |
| 3. Pick-up Roller | 12. Original Exit Sensor |

Ex. 25 (C2030-C2550 Service manual.pdf , p.944).

Paper Feed and Separation Mechanism

2.2 PAPER FEED AND SEPARATION MECHANISM

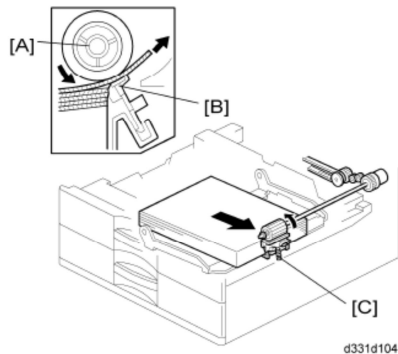

The paper tray holds 500 sheets. The paper feed roller [A] drives the top sheet of paper from the paper tray to the copier/printer. The friction pad [B] allows only one sheet to feed at a time. The friction pad applies pressure to the feed roller with a spring [C].

Ex. _ (C2030-C2550 Service manual.pdf, p.918).

121. Claim limitation 1[c] is satisfied for at least the following reasons. As shown below, Ricoh Aficio MP C2030 includes a retarding roller or a separation roller (see separation roller [D]) to drive the second surface of a sheet in the sheet path – “as shown the top most sheet is separated from the stack by the separation roller [D] and sent to the skew correction roller”.

Basic Operation

2.2.3 PICK-UP AND SEPARATION

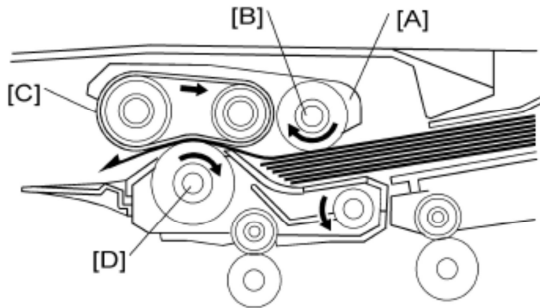

The original is set with the image facing up. The original pushes actuator and the original set sensor is activated.

After pressing the start button, the feed clutch is activated and the original feed unit [A] moves down. At the same time, the pick-up solenoid is activated and the original table lifts until the original comes in contact with the pick-up roller [B]. The pick-up roller then feeds the top sheet of paper.

After being fed from feed belt [C], the topmost sheet is separated from the stack by the separation roller [D] and sent to the skew correction roller.

The mechanism is an FRR system, consisting of the original feed belt [C] and separation roller [D].

Ex. 25 (C2030-C2550 Service manual.pdf).

122. In addition, as shown below, the separation function is driven by the feed belt, positioned to drive forward the first surface of a sheet and a separation roller (retarding roller), positioned to drive the second surface of a sheet. The separation roller [1] (retarding roller) is positioned to drive the second surface of a sheet in the sheet path.

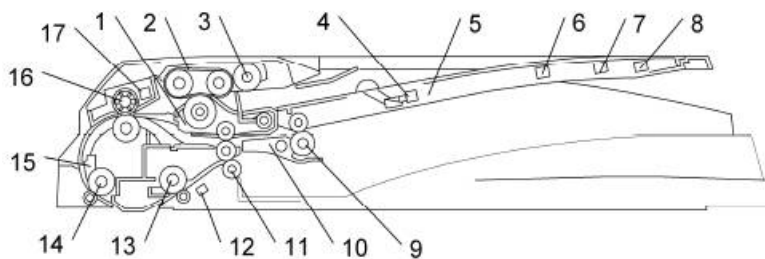

- | | |
|----------------------|--------------------------|
| 1. Separation Roller | 10. Junction Gate |
| 2. Paper Feed Belt | 11. Exit Roller |
| 3. Pick-up Roller | 12. Original Exit Sensor |

Ex. 25 (C2030-C2550 Service manual.pdf).

123. Furthermore, a separation roller [3] is positioned under the feed belt [4] to drive the second surface of a sheet as shown below:

2.1.3 DRIVE LAYOUT

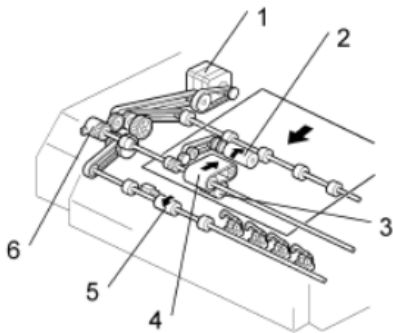

- 1. Feed Motor
- 2. Pick-up Roller
- 3. Separation Roller
- 4. Feed Belt
- 5. Skew Correction Roller
- 6. Feed Clutch

Ex. 25 (C2030-C2550 Service manual.pdf).

124. Claim limitation 1[d] is satisfied for at least the following reasons. As shown below, Ricoh Aficio MP C2030 includes a drive or feed motor (e.g., Feed Motor [5]) for driving the retarding roller backward to cause separation of the top sheet. For example, the drive layout shows that the drive is a “Feed motor: Drives the feed belt, separation, pick-up, and skew correction rollers.” The Paper Feed Motor is also shown below which is responsible for driving the feed belt, separation, pick-up, and skew correction rollers for purposes of driving the retarding roller backwards.

Drive Components

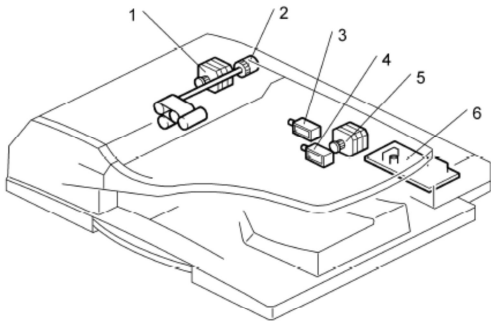

1. Transport Motor
2. Feed Clutch
3. Pick-up Solenoid
4. Inverter Solenoid
5. Feed Motor
6. Main Board

Ex. 25 (C2030-C2550 Service manual.pdf).

2.1.3 DRIVE LAYOUT

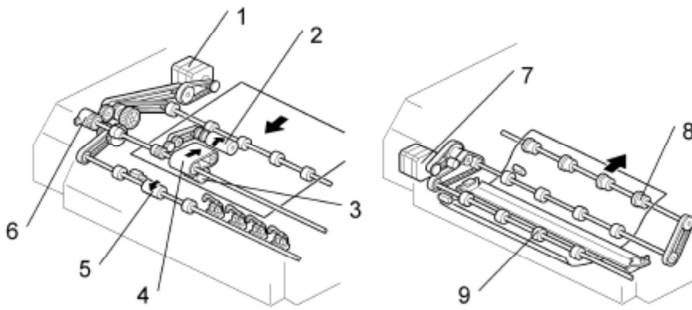

1. Feed Motor
2. Pick-up Roller
3. Separation Roller
4. Feed Belt
5. Skew Correction Roller
6. Feed Clutch
7. Transport Motor
8. Exit Roller
9. Registration Roller

- Feed Motor: Drives the feed belt, separation, pick-up, and skew correction rollers.
- Transport Motor: Drives the registration and exit rollers.

Ex. 25 (C2030-C2550 Service manual.pdf).

1.2.1 PAPER FEED MOTOR

1. Rear Cover (← Rear Cover)

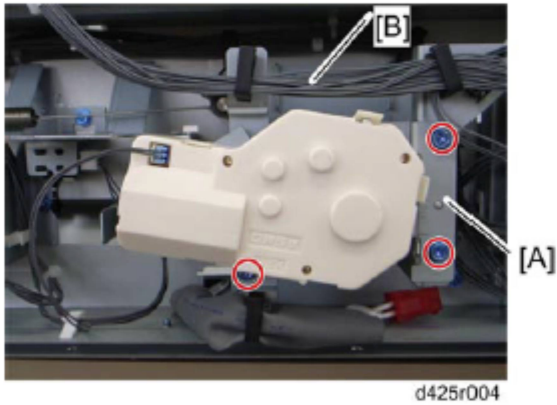

Ex. 25 (C2030-C2550 Service manual.pdf).

125. Claim limitation 1[e] is satisfied for at least the following reasons. As shown below, Ricoh Aficio MP C2030 includes a roller shaft (referred to as the “Separation Roller” in the image below), on which the retarding roller is mounted, and extends axially from the retarding roller.

1.2.4 SEPARATION ROLLER

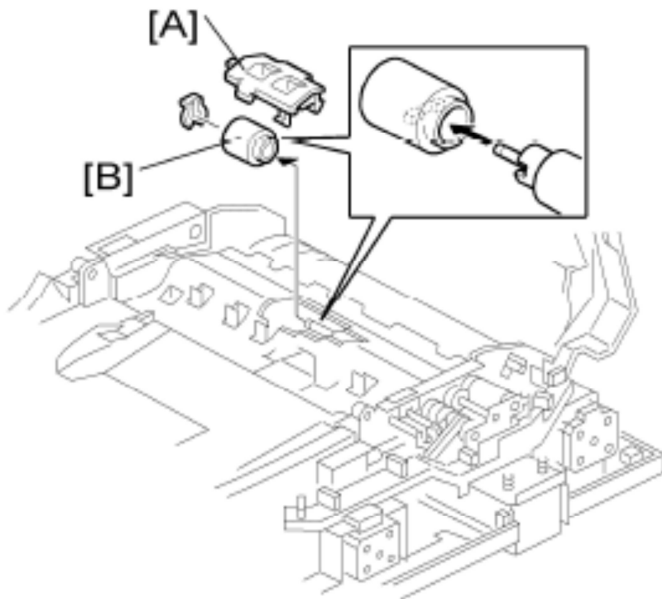

Ex. 25 (C2030-C2550 Service manual.pdf).

126. Claim limitation 1[f] is satisfied for at least the following reasons. As shown below, Ricoh Aficio MP C2030 includes a friction clutch (feed clutch [6]) which is spaced from the retarding roller (separation roller [3]) and connects the drive (feed motor [1]) with the roller shaft.

2.1.3 DRIVE LAYOUT

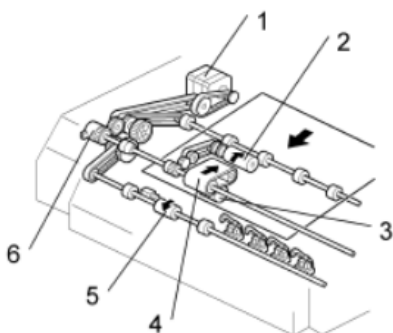

- 1. Feed Motor
- 2. Pick-up Roller
- 3. Separation Roller
- 4. Feed Belt
- 5. Skew Correction Roller
- 6. Feed Clutch

Ex. 25 (C2030-C2550 Service manual.pdf).

127. In addition, Ricoh Aficio MP C2030 includes a friction clutch or paper feed clutch [A] spaced from the retarding roller that “drives the feed belt, separation, pick-up, and skew correction rollers.”

1.2.3 PAPER FEED CLUTCH

1. Rear Cover (↖ Rear Cover)
2. Rear right bracket (↖ Transport Motor)

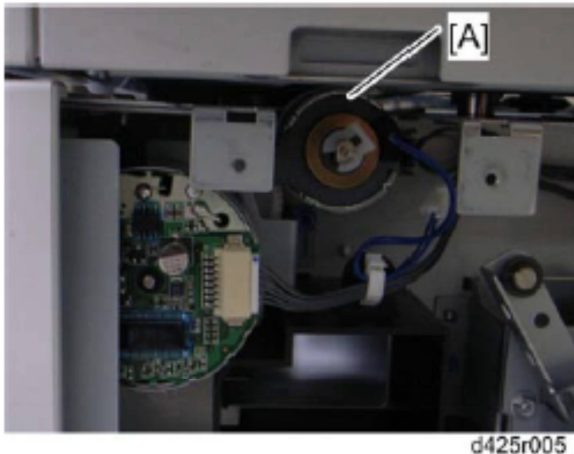

3. Paper feed clutch [A] (🔧 x 1, 📏 x 1, 🌀 x 1)

Magnetic Clutches		
MC1	Feed	Drives the feed belt, separation, pick-up, and skew correction rollers

Ex. 25 (C2030-C2550 Service manual.pdf).

128. Furthermore, Ricoh Aficio MP C2030 includes a friction clutch or feed clutch [B] that is spaced from the retarding roller and connects the drive with the roller shaft as shown below.

1.4.4 FEED CLUTCH

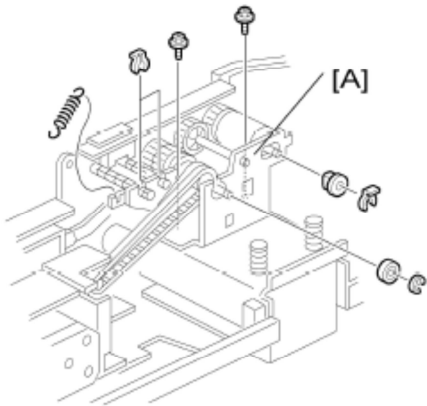

1. Rear cover (see "Rear Cover")
2. Harness guide (see "Pick-up Solenoid")
3. Bracket [A] (⌀ x 2, ⌀ x 3, Ⓒ x 1, bushing x 1, spring x 1)

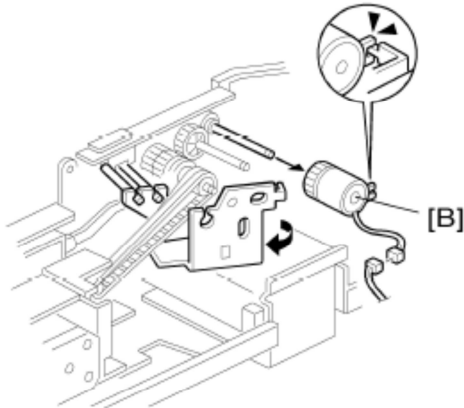

4. Slide the bracket.
5. Feed clutch [B] (⌀ x 1)

Ex. 25 (C2030-C2550 Service manual.pdf).

2.2.3 PICK-UP AND SEPARATION

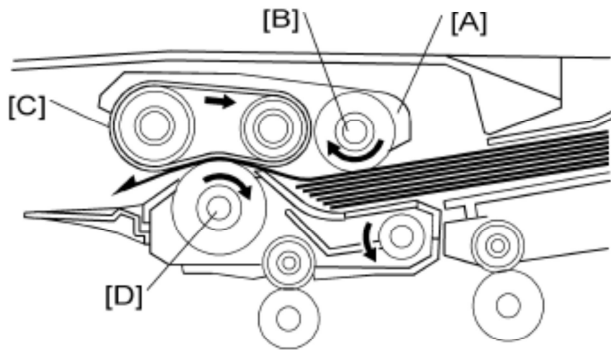

The original is set with the image facing up. The original pushes actuator and the original set sensor is activated.

After pressing the start button, the feed clutch is activated and the original feed unit [A] moves down. At the same time, the pick-up solenoid is activated and the original table lifts until the original comes in contact with the pick-up roller [B]. The pick-up roller then feeds the top sheet of paper.

After being fed from feed belt [C], the topmost sheet is separated from the stack by the separation roller [D] and sent to the skew correction roller.

The mechanism is an FRR system, consisting of the original feed belt [C] and separation roller [D].

Ex. 25 (C2030-C2550 Service manual.pdf).

129. Claim limitation 1[g] is satisfied for at least the following reasons. As shown below, Ricoh Aficio MP C2030 includes a friction clutch which permits the retarding roller to be driven forward when fewer than two sheets are engaged. In one example, a friction clutch (feed clutch [D]) controls the direction of the rotation of the feed motor [B] and also drives the retarding (separation) roller when a single sheet of paper is engaged (i.e., fewer than two sheets are engaged).

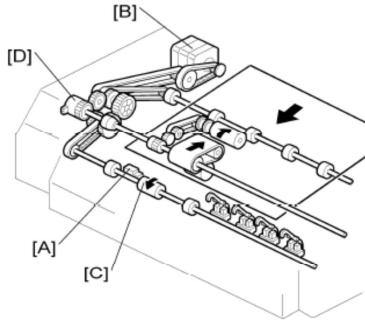

When an original is fed into the feeder, the feed motor [B] rotates forwards. At this time, the feed belt turns but the skew correction roller [C] does not. Because of this, when the leading edge of the paper gets to the skew correction roller, skew in the original is removed. A short time after the leading edge of the original turns on the skew correction sensor [A], the feed motor [B] turns off for 40 ms and rotates in reverse. At this time, the skew correction roller [C] and the feed belt both turn, and original feed continues. The original is fed by the skew correction roller after the feed clutch [D] has turned off.

Ex. 25 (C2030-C2550 Service manual.pdf).

Magnetic Clutches		
MC1	Feed	Drives the feed belt, separation, pick-up, and skew correction rollers

Ex. 25 (C2030-C2550 Service manual.pdf).

130. Claim limitation 1[h] is satisfied for at least the following reasons. As shown below, Ricoh Aficio MP C2030 includes a friction clutch that permits the retarding roller to be driven backward when two or more sheets are engaged by said advancing and retarding rollers. A friction clutch (feed clutch) controls the retarding (separation) roller and permits retarding roller to be driven backward when two or more sheets are engaged by the printer. When the leading edge of the paper gets to the skew correction roller, the feed motor rotates in reverse to cause the retarding roller to be driven backwards.

Magnetic Clutches		
MC1	Feed	Drives the feed belt, separation, pick-up, and skew correction rollers

Ex. 25 (C2030-C2550 Service manual.pdf).

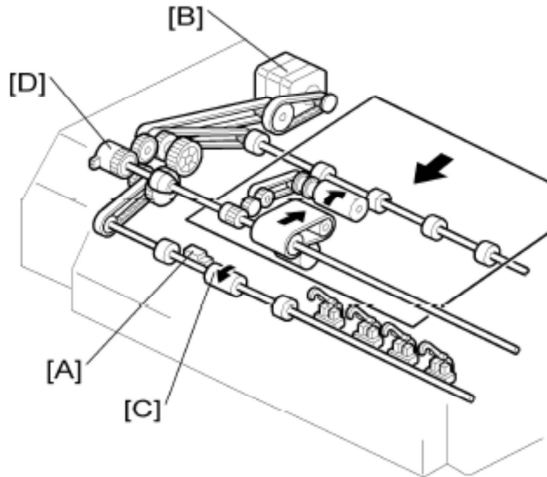

When an original is fed into the feeder, the feed motor [B] rotates forwards. At this time, the feed belt turns but the skew correction roller [C] does not. Because of this, when the leading edge of the paper gets to the skew correction roller, skew in the original is removed. A short time after the leading edge of the original turns on the skew correction sensor [A], the feed motor [B] turns off for 40 ms and rotates in reverse. At this time, the skew correction roller [C] and the feed belt both turn, and original feed continues. The original is fed by the skew correction roller after the feed clutch [D] has turned off.

Ex. 25 (C2030-C2550 Service manual.pdf).

131. Ricoh also infringes under the doctrine of equivalents because it meets at least, and by way of example, the following claim limitation(s) of representative Claim 1 by performing substantially the same function as this limitation, performing this function in substantially the same way as this limitation and achieving substantially the same results as claim limitation 1[g]. For example, and without limitation, Ricoh Aficio MP C2030 performs substantially the same function in substantially the same way and achieves substantially the same result at least because they include a clutch to engage a roller in such a way that the roller only allows one sheet of paper to progress into the printer.

132. As a result of Defendant's unlawful activities, MASA has suffered and will continue to suffer irreparable harm for which there is no adequate remedy at law. Accordingly, MASA is entitled to preliminary and/or permanent injunctive relief.

133. Defendant's infringement of the '684 Patent has injured and continues to injure MASA in an amount to be proven at trial.

COUNT III

(Direct Infringement of the '314 Patent pursuant to 35 U.S.C. § 271(a))

134. MASA repeats, realleges, and incorporates by reference, as if fully set forth herein, the allegations of the preceding paragraphs, as set forth above.

135. Defendant has infringed and continues to infringe one or more claims of the '314 Patent, including at least claim 1, in violation of 35 U.S.C. § 271(a).

136. Defendant's infringement is based upon literal infringement or infringement under the doctrine of equivalents, or both.

137. Defendant's acts of making, using, importing, selling, and/or offering for sale infringing products and services have been without the permission, consent, authorization, or license of MASA.

138. Defendant's infringement includes the manufacture, use, sale, importation and/or offer for sale of Defendant's products and services, such as Ricoh TotalFlow.

139. Claim 1 of the '314 Patent is recited below:

An interface, implemented in a computer, for representing and controlling a production printing workflow comprising:

1[a] a display;

1[b] a first document object representing a document, said document further comprising content and formatting, said formatting defining at least one page in said document, said first document object being associated with a first visual representation on said display;

1[c] a document ticket object representing global document attributes, said document ticket object being associated with a second visual representation on said display and capable of being associated with said first document object;

1[d] a page object representing a page attribute of one of said at least one page, said page object being associated with a third visual representation on said display and capable of being associated with said first document object; and

1[e] a first user input device for selectively associating at least two of said first, second and third visual representations;

1[f] wherein association of said first, second and third visual representations results in association of said respective objects.

140. As one example of how the '314 Accused Products infringe at least claim 1, Ricoh TotalFlow meets the limitations of claim 1 of the '314 Patent for at least the reasons described below.

141. As a general matter and as explained below, the limitations of claim 1 are satisfied for a number of reasons. For example, Ricoh TotalFlow is a multifunction printer that includes a graphical user interface ("GUI"), generated by a computer, that displays (represents) a document, that includes at least one page, and print job details in order to produce a printed document (a production workflow). The GUI also enables a user to adjust values using GUI objects displayed on the GUI to produce the printed document in a desirable and efficient manner (control the production printing workflow).

142. As shown in the figure below, Ricoh TotalFlow includes a computer implemented interface because it generates graphics data to render a main graphical user interface ("GUI") to a display. The main GUI represents a production printing workflow because it displays a document (e.g., the document titled "Big Bend Ranch Biking Guide") that includes at least one page (e.g., pages 2-8) and print job details (e.g., selected printer, number of copies, paper details, "Job Setup" GUI object that presents print job details upon selection) that are used to produce at least one printed document. The main GUI interface also controls the production printing workflow because at least one page of the document and print job each include their own respective GUI objects that are displayed within the main GUI and are capable of being adjusted.

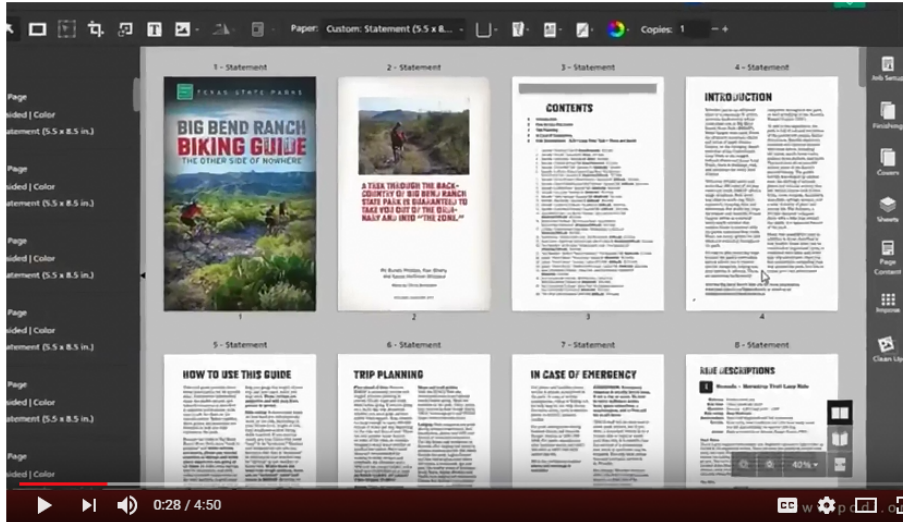

Ex. 26 (PDF of <https://www.youtube.com/watch?v=e9173WVW61Y> (Ricoh TotalFlow Prep PODi Product Briefing)).

143. Claim limitation 1[a] is satisfied for at least the following reasons. As shown below, Ricoh TotalFlow uses a display device (a display) that is coupled to a computer that that runs Ricoh TotalFlow. As shown in the table below, Ricoh TotalFlow meets the recited claim language because Ricoh TotalFlow hardware specifications require, at a minimum, the use of a display the includes 1440 x 9000 pixels or greater (minimum 1,024 x 768 pixels). Ricoh TotalFlow hardware specifications also require, at a minimum, the use of a display that is capable of displaying 16.7 million colors or more (minimum 64,000 colors).

Items	Descriptions			
System Requirements	OS	Edition	32 bit (x86)	64 bit (x64)
	Windows® 7 (SP1)	Professional, Enterprise, Ultimate	X	X
	Windows 8 and 8.1	Professional, Enterprise	X	X
	Windows 10	Professional, Enterprise		X
	Windows Server® 2008 R2	Standard, Enterprise		X
	Windows Server 2012, plus R2	Standard		X
Computer	<ul style="list-style-type: none"> • CPU: 3 GHz or higher recommended (minimum 2 GHz) • Main memory: 8 GB or higher recommended (minimum 4 GB) 			
Hard Disk	<ul style="list-style-type: none"> • 10 GB of available space is recommended for the initial installation 			
Display	<ul style="list-style-type: none"> • 1,440 x 900 pixels or greater recommended (minimum 1,024, x 768 pixels) • 16.7 million colors or more recommended (minimum 64,000 colors) 			
Printer	<ul style="list-style-type: none"> • Printer P53 option may be required 			
Network	<ul style="list-style-type: none"> • Ethernet LAN adapter (at least 100 Mbps, wired LAN recommended) • TCP/IP protocol (IPv4) 			
Web Browser	<ul style="list-style-type: none"> • To use the web browser version of RICOH TotalFlow® Prep, one of the following browsers is required: Internet Explorer® 10 or later, Mozilla Firefox® (current plus two previous versions), Google Chrome™ (current plus two previous versions), Apple® Safari® 7 or 8 			
Flash Player	<ul style="list-style-type: none"> • Adobe® Flash® Player version 11.2 or later required to display web application version of TotalFlow Prep 			
Base Product	<ul style="list-style-type: none"> • RICOH TotalFlow Prep 			

Ex. 27 (TotalFlow_Prep.pdf at page 4).

144. Claim limitation 1[b] is satisfied for at least the following reasons. As shown below, Ricoh TotalFlow stores data values, that represent a document, within a region in memory resident within a computer that executes Ricoh TotalFlow (a first document object representing a document). Ricoh TotalFlow also generates graphics data to render objects that are selectable from the GUI within a main interface (a first visual representation on said display). Documents launched within Ricoh TotalFlow include text and/or image data (content) displayed on the main interface that can be adjusted based in-part on selectable options (said formatting defining at least one page in said document). Modifications made to documents on the main interface correspondingly adjust appropriate document attribute values, for a given document, that are stored in memory (said first document object being associated with a first visual representation on said display).

145. In addition, as shown in the figure below, Ricoh TotalFlow meets the recited claim language because it generates graphics data to display the various pages and document

attributes (content, print settings, and the like) associated with the “Big Bend Ranch Biking Guide” document (a first visual representation on said display) within the main interface. Furthermore, at least one page of the document (e.g., page 2) includes text and/or image data (content).

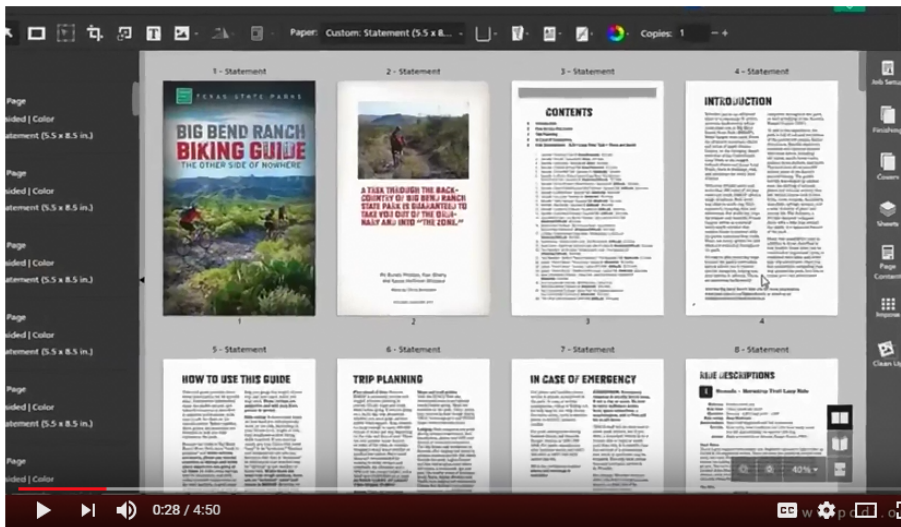

Ex. 26 (PDF of <https://www.youtube.com/watch?v=e9l73WVW61Y> (Ricoh TotalFlow Prep PODi Product Briefing)).

146. As depicted below, Ricoh TotalFlow formats at least one page (e.g., page 5) of the document “Big Bend Ranch Biking Guide” when it performs operations in response a selection of the “edit page” option. Page forming includes the formatting page color, page size for the page (said formatting defining at least one page in said document).

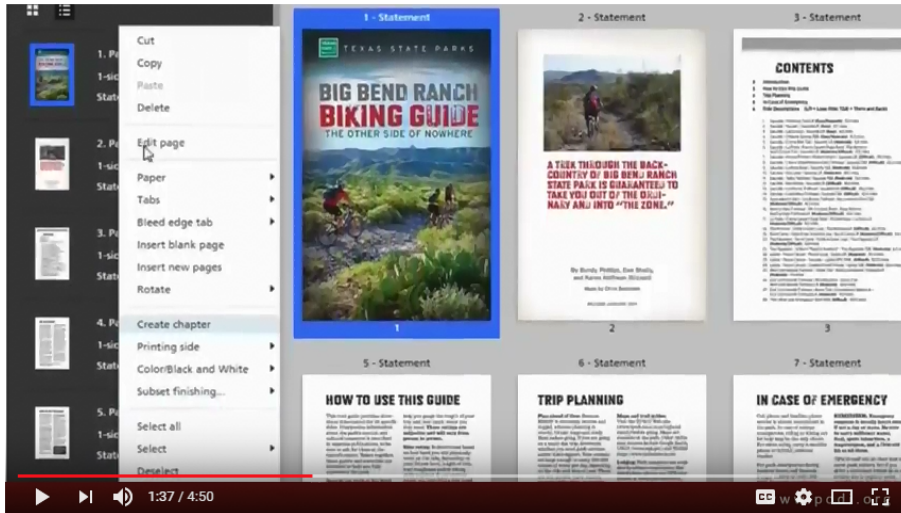

Ex. 26 (PDF of <https://www.youtube.com/watch?v=e9I73WVW61Y> (Ricoh TotalFlow Prep PODi Product Briefing)).

147. In addition, Ricoh TotalFlow stores data values that represent the “Big Bend Ranch Biking Guide” document (e.g., document attribute values) within a region in memory resident within a computer that executes the computer-implemented instructions for Ricoh TotalFlow (a first document object representing a document). In this fashion, modifications made to the “Big Bend Ranch Biking Guide” document correspondingly adjust the appropriate document attribute values for the document stored in memory (said first document object being associated with a first visual representation on said display).

148. Claim limitation 1[c] is satisfied for at least the following reasons. Ricoh TotalFlow stores data values that represent “job setup” data within a region in memory resident within a computer that executes Ricoh TotalFlow (a document ticket object). The job setup data includes document ticket attribute data that can be defined for all pages of a given document (global document attributes) including booklet finishing details, booklet type, simplex/duplex mode, scaling, auto-rotation settings, and the like. In this manner, Ricoh TotalFlow generates graphics data to render a “job setup” selectable in the GUI (a second visual representation on said display) that displays job setup data for the document within the

main interface. Modifications made to values displayed in the job setup GUI tab correspondingly adjust the appropriate data values stored in memory (said document ticket object being associated with a second visual representation on said display). Moreover, modifications made to values displayed in the job setup GUI tab will also correspondingly adjust the appropriate document attribute values, stored in memory, for the document (document ticket object being capable of being associated with said first document object).

149. As shown in the figure below, Ricoh TotalFlow includes a second visual representation on said display because it includes computer-implemented instructions that generate graphics data to render selectable job ticket options that include a “job setup” GUI tab, a “finishing” GUI object, a “covers” GUI object, a “sheets” GUI object, a “page content” GUI object, and an “impose” GUI .

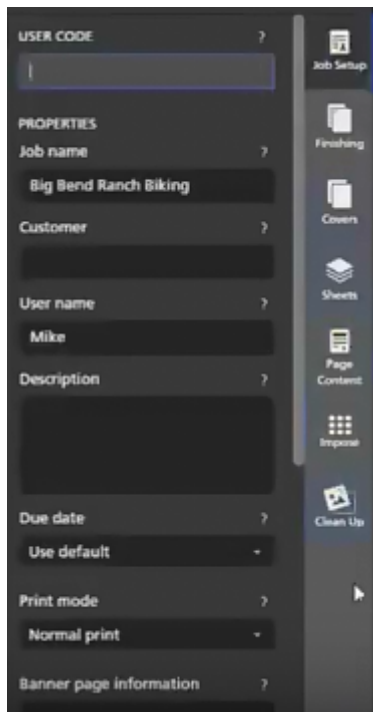

Ex. 26 (PDF of <https://www.youtube.com/watch?v=e9I73WVW61Y> (Ricoh TotalFlow Prep PODi Product Briefing)).

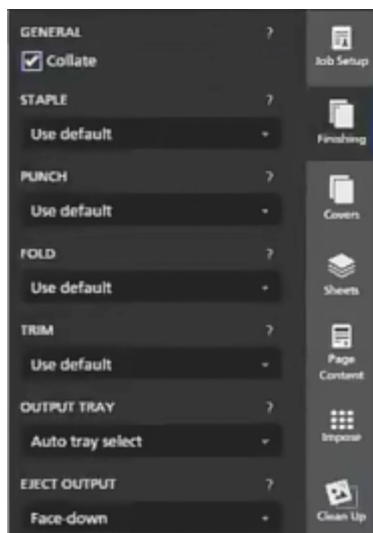

Ex. 26 (PDF of <https://www.youtube.com/watch?v=e9I73WVW61Y> (Ricoh TotalFlow Prep PODi Product Briefing)).

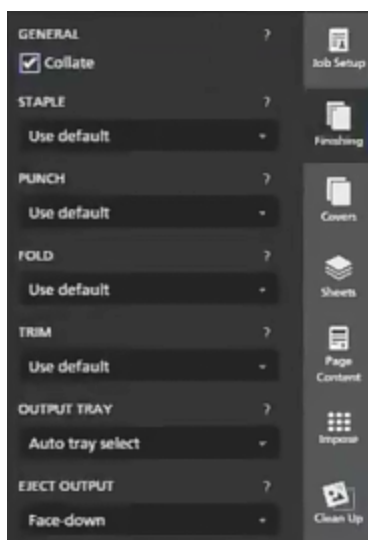

Ex. 26 (PDF of <https://www.youtube.com/watch?v=e9I73WVW61Y> (Ricoh TotalFlow Prep PODi Product Briefing)).

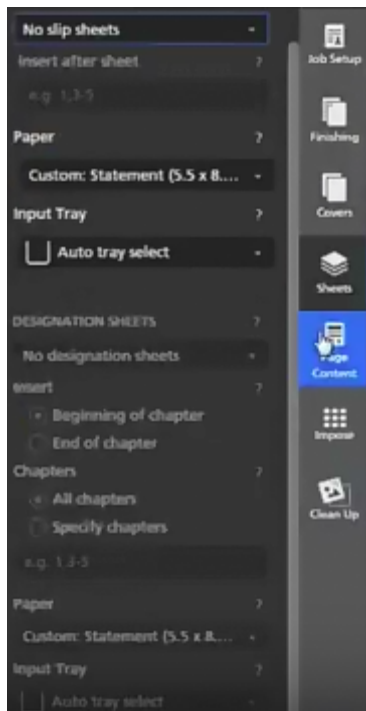

Ex. 26 (PDF of <https://www.youtube.com/watch?v=e9I73WVW61Y> (Ricoh TotalFlow Prep PODi Product Briefing)).

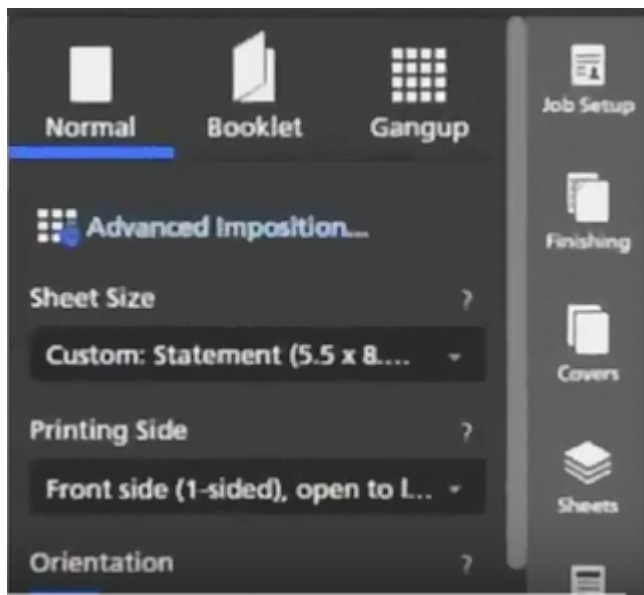

Ex. 26 (PDF of <https://www.youtube.com/watch?v=e9I73WVW61Y> (Ricoh TotalFlow Prep PODi Product Briefing)).

150. Moreover, Ricoh TotalFlow stores data that represent the job ticket data values within a region in memory resident within a computer that executes the computer-implemented

instructions for Ricoh TotalFlow (a document ticket object representing global document attributes). In this fashion, modifications made to values displayed in any of the “job setup,” “finishing,” “covers,” “sheets,” “page content,” and/or “impose” GUI objects will correspondingly adjust the appropriate data values stored in memory (said document ticket object being associated with a second visual representation on said display).

151. Modifications made to values displayed in the job setup GUI tab will also correspondingly adjust the appropriate document attribute values for the “Big Bend Ranch Biking Guide” document stored in memory (document ticket object being capable of being associated with said first document object).

152. Claim limitation 1[d] is satisfied for at least the following reasons. As shown below, Ricoh TotalFlow stores data values that represent “page view” attribute data within a region in memory resident within a computer that executes Ricoh TotalFlow (a page object representing a page attribute of one of said at least one page). Ricoh TotalFlow also generates graphics data to render a selectable “page view” GUI object (a third visual representation on said display). As such, modifications made to a page via the page view GUI correspondingly adjusts the appropriate page attribute values for the page in memory (said page object being associated with a third visual representation on said display). Moreover, modifications made to the page via the page view GUI also correspondingly adjusts the appropriate document attribute values for the document in memory (page object being capable of being associated with said first document object).

153. As shown in the figure below, Ricoh TotalFlow meets the recited claim language because it includes computer-implemented instructions that generate graphics data to render a selectable “page” GUI object (a third visual representation on said display). The selection of

the “page” GUI object presents a display of different options that allow a user to manipulate attributes of a particular page (e.g., cover page) of the “Big Bend Ranch Biking Guide” document (a first document object).

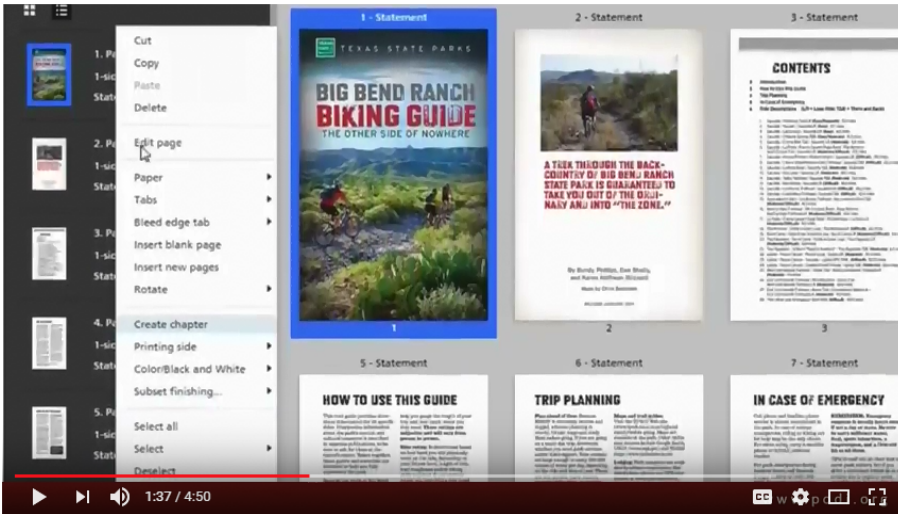

Ex. 26 (PDF of <https://www.youtube.com/watch?v=e9173WVW61Y> (Ricoh TotalFlow Prep PODi Product Briefing)).

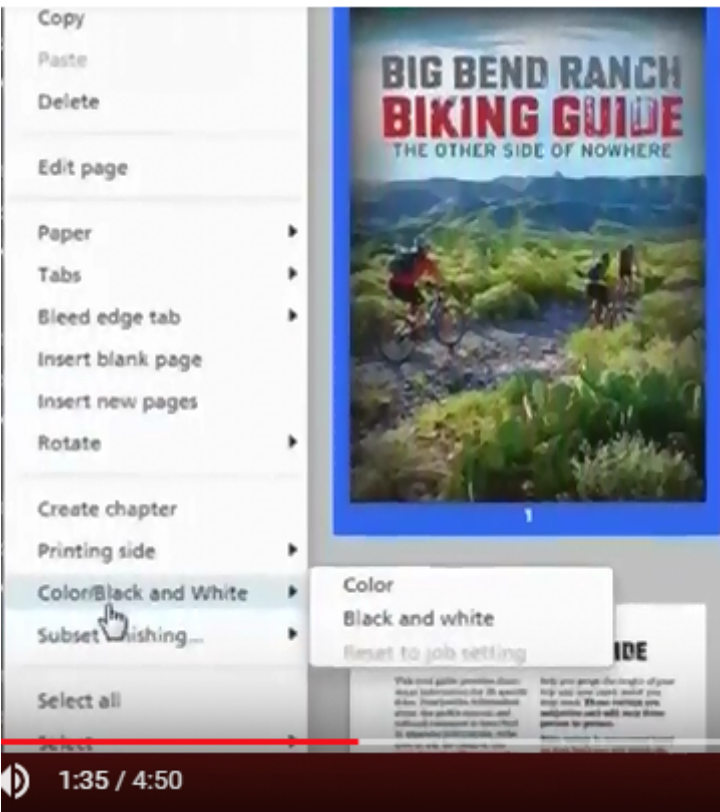

Ex. 26 (PDF of <https://www.youtube.com/watch?v=e9l73WVW61Y> (Ricoh TotalFlow Prep PODi Product Briefing)).

154. Moreover, Ricoh TotalFlow stores data values that represent the “page” attribute values of the cover page within a region in memory resident within a computer that executes the computer-implemented instructions for Ricoh TotalFlow (a page object representing a page attribute of one of said at least one page). In this fashion, modifications made to the cover page (e.g., via the page GUI) will correspondingly adjust the appropriate page attribute values for the page in memory (said page object being associated with a third visual representation on said display).

155. Modifications made to the cover page will also correspondingly adjust the appropriate document attribute values for the “Big Bend Ranch Biking Guide” document itself in memory (page object being capable of being associated with said first document object). For instance, as shown below, the cover page can be modified in order to include color or be displayed as black/white. Accordingly, the selection of either color or black/white will also automatically adjust both (1) the appropriate page attribute values for the cover page in memory and (2) the appropriate document attribute values for the “Big Bend Ranch Biking Guide” document itself in memory.

156. Claim limitation 1[e] is satisfied for at least the following reasons. Ricoh TotalFlow includes one or more input processing software modules (a first user input device) that receives input provided by a user to associate a “job setup” GUI object with a GUI object for a particular document, along with their respective data values stored in memory (selectively associating at least two of said first, second and third visual representations).

157. As shown in the figure below, Ricoh TotalFlow creates a new job using three separate documents (e.g., “Aquatic book 13 pages,” “Aquatic book back cover,” and “Aquatic Book Cover.jpg”) selected by a user. In this fashion, input processing software modules of Ricoh TotalFlow receives user selections provided by a user.

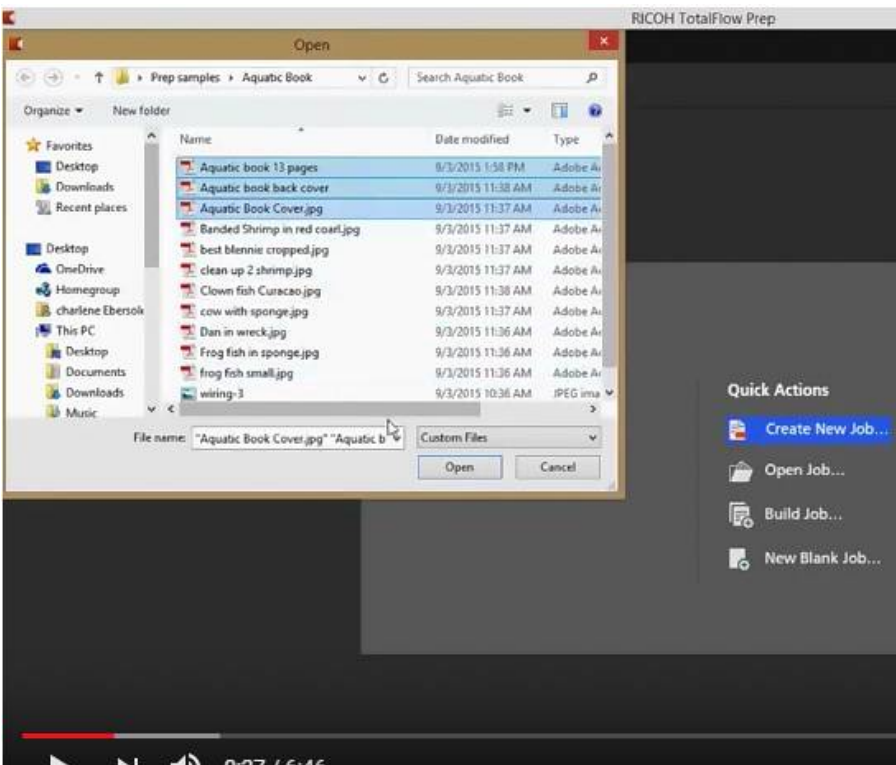

Ex. 28 (PDF of <https://www.youtube.com/watch?v=hk0oKHhRxI4&t=70s> (“TotalFlow Prep Booklets”)).

158. Additionally, as shown in the figure below, Ricoh TotalFlow creates the new job using three separate documents selected by a user. Visual representations of each specific document are visually paired with the newly created job (a second visual representation on said display) because their respective content (e.g., text, images) are displayed as part of the new job. The three separate documents can be combined to form a new single document that is associated with the new job. Accordingly, as depicted below, their respective content are considered to be individual pages (a third visual representation on said display). In this

manner, the visual representations of each page can be (1) associated with the new document object created by the individual documents and (2) associated with the new job as a result of the initial user selection.

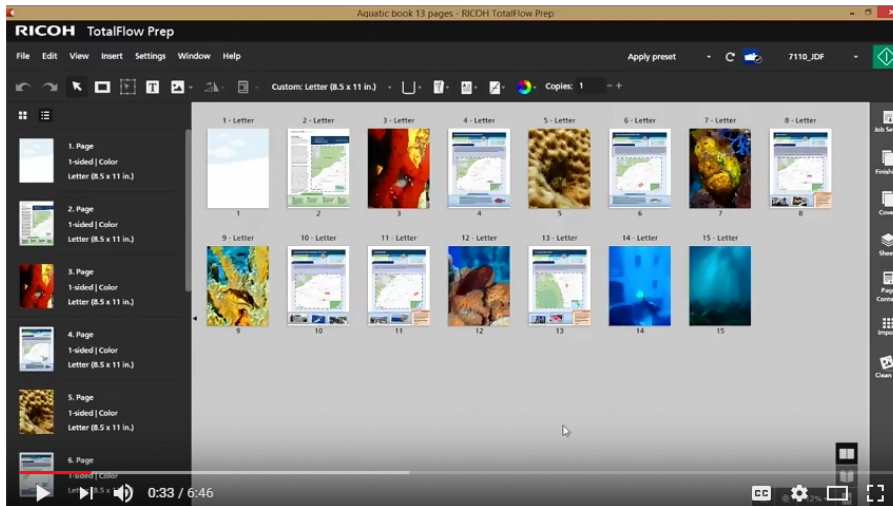

Ex. 28 (PDF of <https://www.youtube.com/watch?v=hk0oKHhRxI4&t=70s> (“TotalFlow Prep Booklets”)).

159. Claim limitation 1[f] is satisfied for at least the following reasons. This claim limitation is satisfied whenever a document is launched since it visually displays the document GUI object (the first visual representation on said display), the document’s job ticket GUI objects (the second visual representation on said display), and the page GUI objects (the third visual representation on said display) all at the same time within the same display. For example, when the document is launched, Ricoh TotalFlow associates the underlying objects of the document, document’s job ticket, and at least one page of the document by displaying their respective values along with the aforementioned GUIs.

160. As shown in the figure below, Ricoh TotalFlow associates said first, second and third visual representations whenever a document (e.g., “Big Bend Ranch Biking Guide”) is loaded and displayed to a user. When the document is loaded, (1) the document’s GUI object

(the first visual representation on said display), (2) the document's job ticket GUI objects, i.e., the "job setup," "finishing," "covers," "sheets," "page content," and "impose" GUI objects (the second visual representation on said display), and (3) page GUI objects (the third visual representation on said display) are all visually displayed at the same time. Accordingly, Ricoh TotalFlow associates each of the respective objects when it displays the respective data values that represent each of the aforementioned GUI objects visually to the user. In this fashion, Ricoh TotalFlow uses identifiers (e.g., document IDs, page IDs, job IDs, and the like) stored in a database or memory structure to retrieve the aforementioned values.

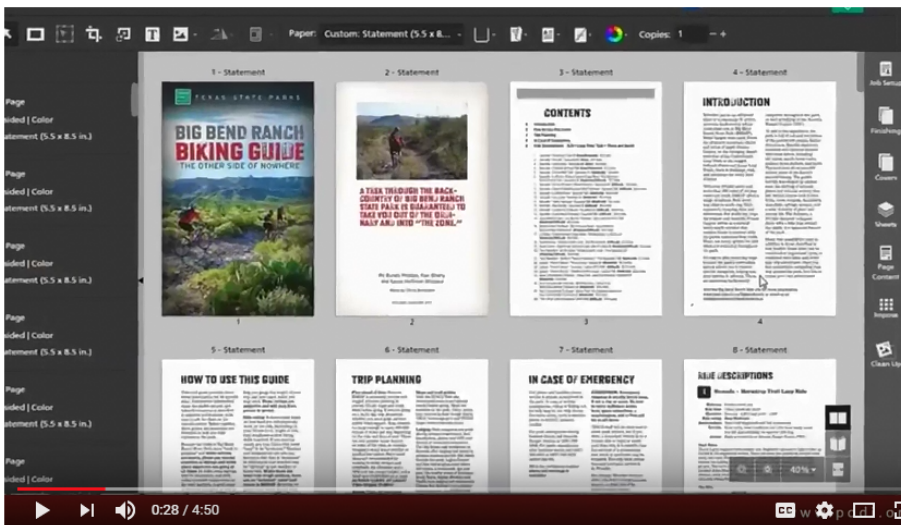

Ex. 26 (PDF of <https://www.youtube.com/watch?v=e9l73WVW61Y> (Ricoh TotalFlow Prep PODi Product Briefing)).

161. Ricoh also infringes under the doctrine of equivalents because it meets at least, and by way of example, the following claim limitation (s) of representative Claim 1 by performing substantially the same function as this limitation, performing this function in substantially the same way as this limitation, and achieving substantially the same results as claim limitation 1[f]. For example, and without limitation, Ricoh TotalFlow performs

substantially the same function in substantially the same way and achieves substantially the same result at least because it generates a display in which data values associated with the underlying objects of a document, the document's job ticket, and at least one page of the document are displayed at the same time within the same display.

162. As a result of Defendant's unlawful activities, MASA has suffered and will continue to suffer irreparable harm for which there is no adequate remedy at law. Accordingly, MASA is entitled to preliminary and/or permanent injunctive relief.

163. Defendant's infringement of the '314 Patent has injured and continues to injure MASA in an amount to be proven at trial.

COUNT IV

(Direct Infringement of the '756 Patent pursuant to 35 U.S.C. § 271(a))

164. MASA repeats, realleges, and incorporates by reference, as if fully set forth herein, the allegations of the preceding paragraphs, as set forth above.

165. Defendant has infringed and continues to infringe one or more claims of the '756 Patent, including at least claim 1, in violation of 35 U.S.C. § 271(a).

166. Defendant's infringement is based upon literal infringement or infringement under the doctrine of equivalents, or both.

167. Defendant's acts of making, using, importing, selling, and/or offering for sale infringing products and services have been without the permission, consent, authorization, or license of MASA.

168. Defendant's infringement includes the manufacture, use, sale, importation and/or offer for sale of Defendant's products and services, such as Ricoh TotalFlow.

169. Claim 1 of the '756 Patent is recited below:

An interface, implemented in a computer, for representing and controlling a production printing workflow comprising:

1[a] a display;

1[b] a first document object representing a document, said document further comprising content and formatting, said formatting defining at least one page in said document, said first document object being associated with a first visual representation on said display;

1[c] a document ticket object representing global document attributes, said document ticket object being associated with a second visual representation on said display and capable of being associated with said first document object;

1[d] a page object representing a page attribute of one of said at least one page, said page object being associated with a third visual representation on said display and capable of being associated with said first document object; and

1[e] a first user input device for selectively associating at least two of said first, second and third visual representations;

1[f] a second user input device for creating said page object, said second user input device operative to allow selection of said page attribute, setting of a value of said page attribute and selection of one or more of said at least one page in said document to apply said page attribute to wherein upon application, one or more of said page objects are created and associated with each of said one or more of said at least one page and said corresponding document object;

1[g] wherein association of said first, second and third visual representations results in association of said respective objects;

1[h] and further wherein said applied page attribute is visually represented on a visual representation of said one or more of said at least one page.

170. As one example of how the '756 Accused Products infringe at least claim 1, Ricoh TotalFlow meets the limitations of claim 1 of the '756 Patent for at least the reasons described below.

171. As a general matter, the limitations of claim 1 are satisfied for the reasons described below. Ricoh TotalFlow includes a graphical user interface generated by a computer, that displays (represents) a document, that includes at least one page, and print job details in order to produce a printed document (a production workflow). The GUI also enables a user to adjust values using GUI objects displayed on the GUI to produce the printed document in a desirable and efficient manner (control the production printing workflow).

172. As shown in the figure below, Ricoh TotalFlow includes a computer implemented interface because it generates graphics data to render a main graphical user interface (“GUI”) to a display. The main GUI represents a production printing workflow because it displays a document (e.g., the document titled “Big Bend Ranch Biking Guide”) that includes at least one page (e.g., pages 2-8) and print job details (e.g., selected printer, number of copies, paper details, “Job Setup” GUI object that presents print job details upon selection) that are used to produce at least one printed document. The main GUI interface controls the production printing workflow because at least one page of the document and print job each include their own respective GUI objects that are displayed within the main GUI and are capable of being adjusted.

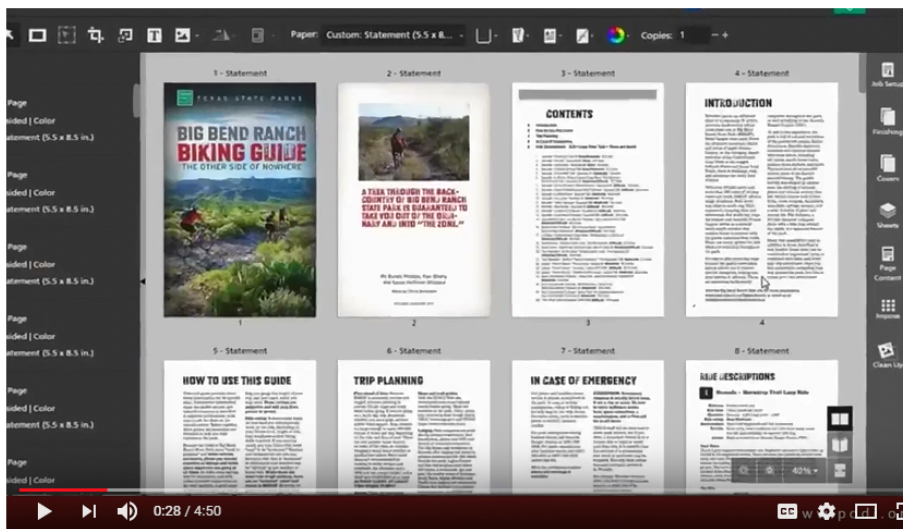

Ex. 26 (PDF of <https://www.youtube.com/watch?v=e9l73WVW61Y> (Ricoh TotalFlow Prep PODi Product Briefing)).

173. Claim limitation 1[a] is satisfied for at least the following reasons. As shown below, Ricoh TotalFlow uses a display device (a display) that is coupled to a computer that runs Ricoh TotalFlow.

174. As shown in the table below, Ricoh TotalFlow hardware specifications require, at a minimum, the use of a display that includes 1440 x 9000 pixels or greater (minimum 1,024 x 768 pixels). Also, Ricoh TotalFlow hardware specifications require, at a minimum, the use of a display that is capable of displaying 16.7 million colors or more (minimum 64,000 colors).

Items	Descriptions			
System Requirements	OS	Edition	32 bit (x86)	64 bit (x64)
	Windows® 7 (SP1)	Professional, Enterprise, Ultimate	X	X
	Windows 8 and 8.1	Professional, Enterprise	X	X
	Windows 10	Professional, Enterprise		X
	Windows Server® 2008 R2	Standard, Enterprise		X
	Windows Server 2012, plus R2	Standard		X
Computer	<ul style="list-style-type: none"> • CPU: 3 GHz or higher recommended (minimum 2 GHz) • Main memory: 8 GB or higher recommended (minimum 4 GB) 			
Hard Disk	<ul style="list-style-type: none"> • 10 GB of available space is recommended for the initial installation 			
Display	<ul style="list-style-type: none"> • 1,440 x 900 pixels or greater recommended (minimum 1,024, x 768 pixels) • 16.7 million colors or more recommended (minimum 64,000 colors) 			
Printer	<ul style="list-style-type: none"> • Printer P53 option may be required 			
Network	<ul style="list-style-type: none"> • Ethernet LAN adapter (at least 100 Mbps, wired LAN recommended) • TCP/IP protocol (IPv4) 			
Web Browser	<ul style="list-style-type: none"> • To use the web browser version of RICOH TotalFlow® Prep, one of the following browsers is required: Internet Explorer® 10 or later, Mozilla Firefox® (current plus two previous versions), Google Chrome™ (current plus two previous versions), Apple® Safari® 7 or 8 			
Flash Player	<ul style="list-style-type: none"> • Adobe® Flash® Player version 11.2 or later required to display web application version of TotalFlow Prep 			
Base Product	<ul style="list-style-type: none"> • RICOH TotalFlow Prep 			

Ex. 27 (TotalFlow_Prep.pdf at page 4).

175. Claim limitation 1[b] is satisfied for at least the following reasons. Ricoh TotalFlow stores data values that represent a document, within a region in memory resident within a computer that executes Ricoh TotalFlow (a first document object representing a document). Ricoh TotalFlow also generates graphics data to render selectable GUI objects within a main interface (a first visual representation on said display). Documents launched within Ricoh TotalFlow include text and/or image data (content) displayed on the main interface that can be adjusted based in-part on selectable options (said formatting defining at least one page in said document). Modifications made to documents on the main interface

correspondingly adjust appropriate document attribute values, for a given document, that are stored in memory (said first document object being associated with a first visual representation on said display).

176. As shown below, Ricoh TotalFlow generates graphics data to display the various pages and document attributes (content, print settings, and the like) associated with the “Big Bend Ranch Biking Guide” document (a first visual representation on said display) within the main interface. Furthermore, as depicted below, at least one page of the document (e.g., page 2) includes text and/or image data (content).

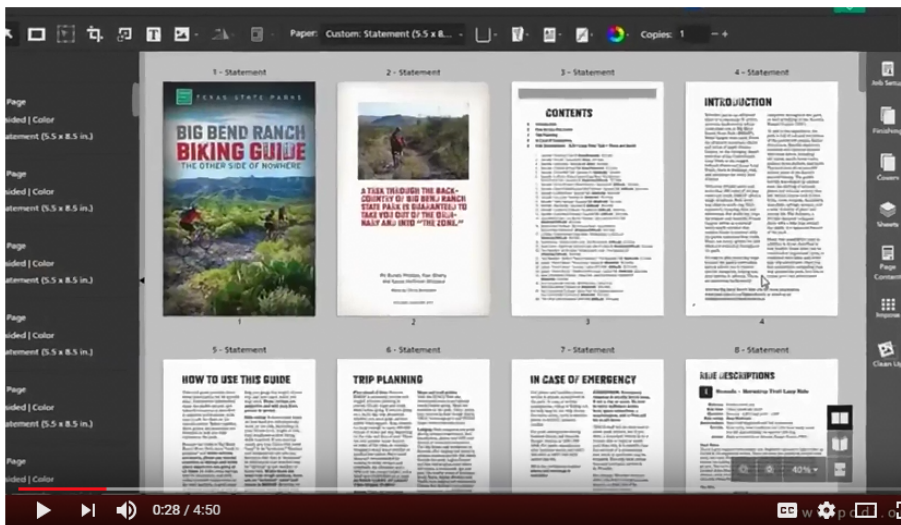

Ex. 26 (PDF of <https://www.youtube.com/watch?v=e9l73WW61Y> (Ricoh TotalFlow Prep PODi Product Briefing)).

177. As depicted below, Ricoh TotalFlow formats at least one page (e.g., page 5) of the document “Big Bend Ranch Biking Guide” when it performs operations in response a selection of the “edit page” option. Page forming includes the formatting page color, page size for the page (said formatting defining at least one page in said document).

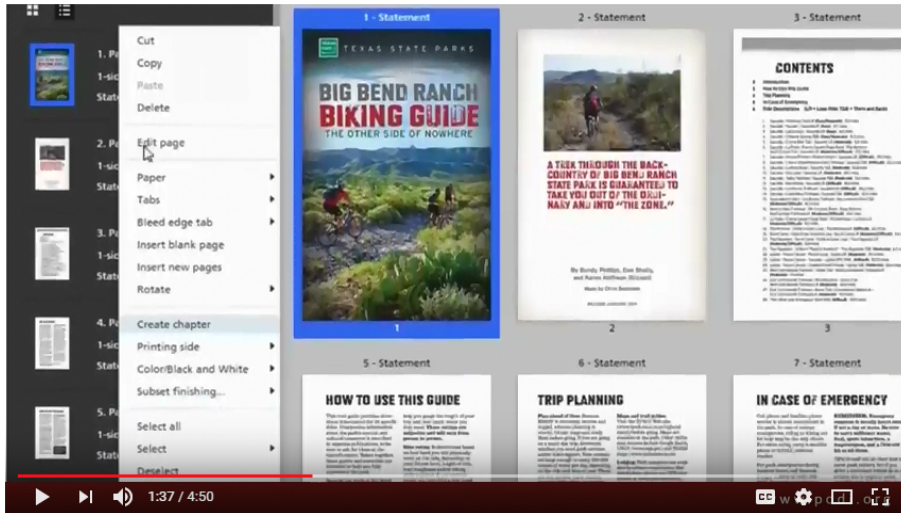

Ex. 26 (PDF of <https://www.youtube.com/watch?v=e9l73WVW61Y> (Ricoh TotalFlow Prep PODi Product Briefing)).

178. Ricoh TotalFlow stores data values that represent the “Big Bend Ranch Biking Guide” document (e.g., document attribute values) within a region in memory resident within a computer that executes the computer-implemented instructions for Ricoh TotalFlow (a first document object representing a document). In this fashion, modifications made to the “Big Bend Ranch Biking Guide” document correspondingly adjust the appropriate document attribute values for the document stored in memory (said first document object being associated with a first visual representation on said display).

179. Claim limitation 1[c] is satisfied for at least the following reasons. Ricoh TotalFlow stores data values that represent “job setup” data within a region in memory resident within a computer that executes Ricoh TotalFlow (a document ticket object). The job setup data includes document ticket attribute data that can be defined for all pages of a given document (global document attributes) including booklet finishing details, booklet type, simplex/duplex mode, scaling, auto-rotation settings, and the like. In this manner, Ricoh TotalFlow generates graphics data to render a selectable “job setup” GUI tab (a second visual representation on said display) that displays job setup data for the document within the main

interface. Modifications made to values displayed in the job setup GUI tab correspondingly adjust the appropriate data values stored in memory (said document ticket object being associated with a second visual representation on said display). Moreover, modifications made to values displayed in the job setup GUI tab will also correspondingly adjust the appropriate document attribute values, stored in memory, for the document (document ticket object being capable of being associated with said first document object).

180. As shown in the figure below, Ricoh TotalFlow includes a second visual representation on said display because it includes computer-implemented instructions that generate graphics data to render selectable job ticket options that include a “job setup” GUI tab, a “finishing” GUI object, a “covers” GUI object, a “sheets” GUI object, a “page content” GUI object, and an “impose” GUI .

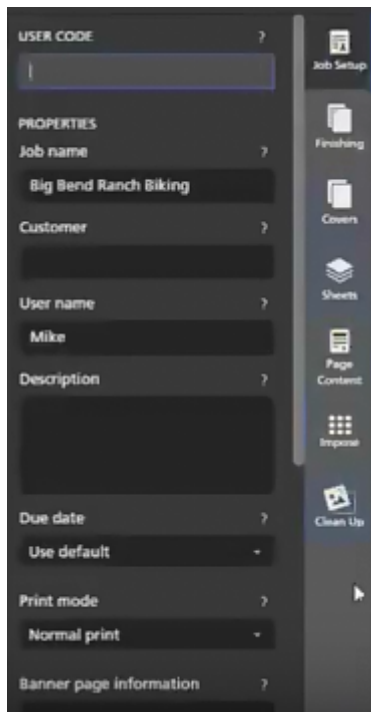

Ex. 26 (PDF of <https://www.youtube.com/watch?v=e9I73WVW61Y> (Ricoh TotalFlow Prep PODi Product Briefing)).

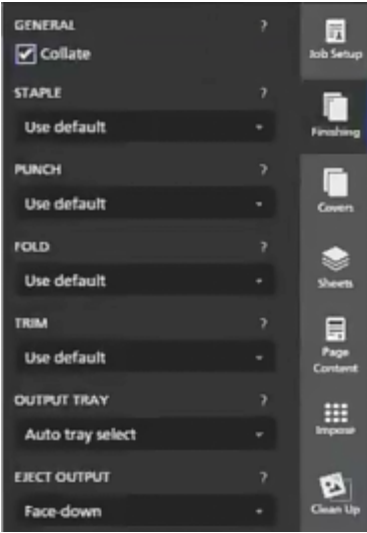

Ex. 26 (PDF of <https://www.youtube.com/watch?v=e9I73WVW61Y> (Ricoh TotalFlow Prep PODi Product Briefing)).

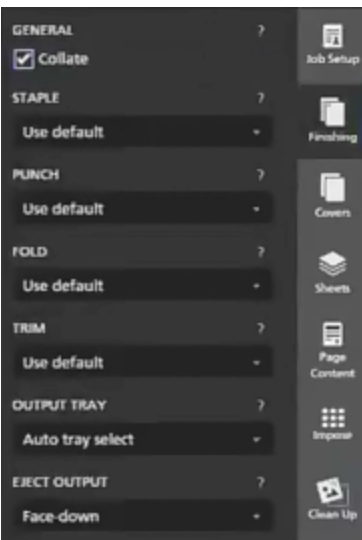

Ex. 26 (PDF of <https://www.youtube.com/watch?v=e9I73WVW61Y> (Ricoh TotalFlow Prep PODi Product Briefing)).

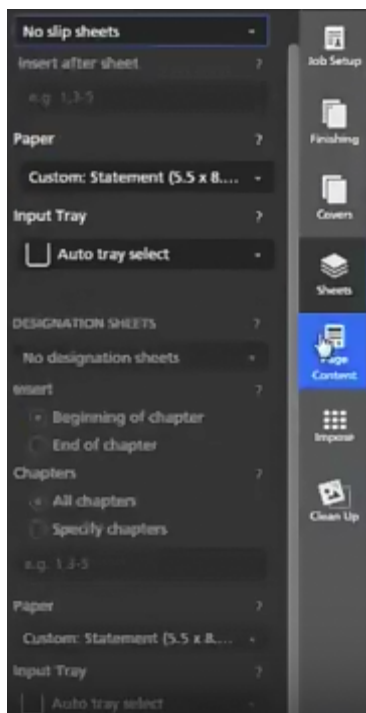

Ex. 26 (PDF of <https://www.youtube.com/watch?v=e9l73WVW61Y> (Ricoh TotalFlow Prep PODi Product Briefing)).

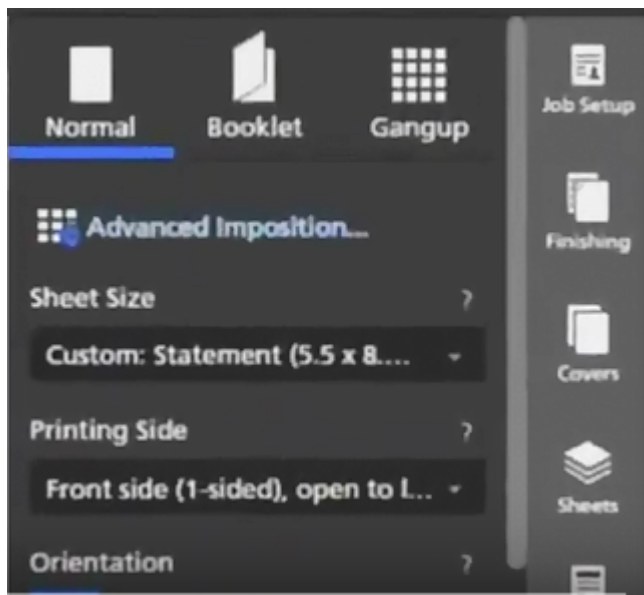

Ex. 26 (PDF of <https://www.youtube.com/watch?v=e9l73WVW61Y> (Ricoh TotalFlow Prep PODi Product Briefing)).

181. Ricoh TotalFlow stores data that represent the job ticket data values within a region in memory resident within a computer that executes the computer-implemented

instructions for Ricoh TotalFlow (a document ticket object representing global document attributes). In this fashion, modifications made to values displayed in any of the “job setup,” “finishing,” “covers,” “sheets,” “page content,” and/or “impose” GUI objects will correspondingly adjust the appropriate data values stored in memory (said document ticket object being associated with a second visual representation on said display).

182. Modifications made to values displayed in the job setup GUI tab will also correspondingly adjust the appropriate document attribute values for the “Big Bend Ranch Biking Guide” document stored in memory (document ticket object being capable of being associated with said first document object).

183. Claim limitation 1[d] is satisfied for at least the following reasons. Ricoh TotalFlow stores data values that represent “page view” attribute data within a region in memory resident within a computer that executes Ricoh TotalFlow (a page object representing a page attribute of one of said at least one page). Ricoh TotalFlow also generates graphics data to render a selectable “page view” GUI object (a third visual representation on said display). As such, modifications made to a page via the page view GUI correspondingly adjusts the appropriate page attribute values for the page in memory (said page object being associated with a third visual representation on said display). Moreover, modifications made to the page via the page view GUI also correspondingly adjusts the appropriate document attribute values for the document in memory (page object being capable of being associated with said first document object).

184. As shown in the figure below, Ricoh TotalFlow meets the recited claim language because it includes computer-implemented instructions that generate graphics data to render a selectable “page” GUI object (a third visual representation on said display). The selection of

the “page” GUI object presents a display of different options that allow a user to manipulate attributes of a particular page (e.g., cover page) of the “Big Bend Ranch Biking Guide” document (a first document object).

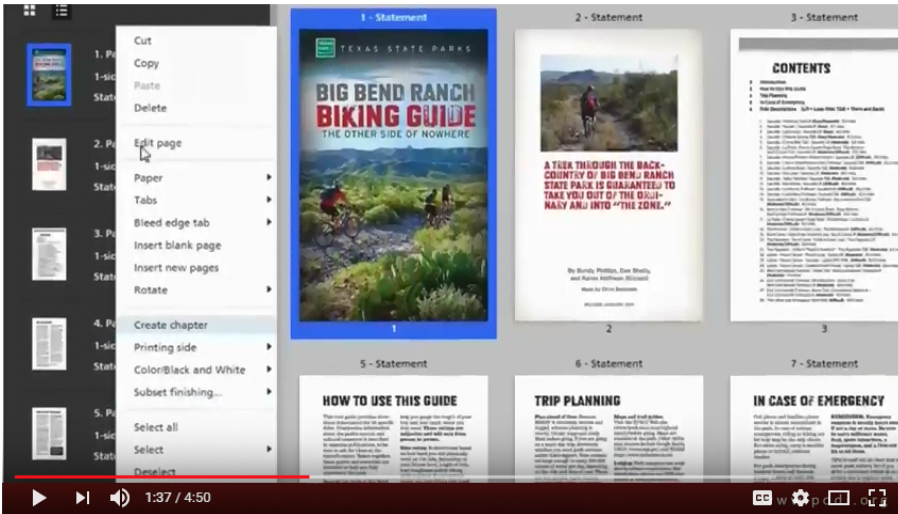

Ex. 26 (PDF of <https://www.youtube.com/watch?v=e9I73WVW61Y> (Ricoh TotalFlow Prep PODi Product Briefing)).

185. Ricoh TotalFlow stores data values that represent the “page” attribute values of the cover page within a region in memory resident within a computer that executes the computer-implemented instructions for Ricoh TotalFlow (a page object representing a page attribute of one of said at least one page). In this fashion, modifications made to the cover page (e.g., via the page GUI) will correspondingly adjust the appropriate page attribute values for the page in memory (said page object being associated with a third visual representation on said display).

186. Modifications made to the cover page will also correspondingly adjust the appropriate document attribute values for the “Big Bend Ranch Biking Guide” document itself in memory (page object being capable of being associated with said first document object). For instance, as shown below, the cover page can be modified in order to include color or be

displayed as black/white. Accordingly, the selection of either color or black/white will also automatically adjust both (1) the appropriate page attribute values for the cover page in memory and (2) the appropriate document attribute values for the “Big Bend Ranch Biking Guide” document itself in memory.

187. Claim limitation 1[e] is satisfied for at least the following reasons. Ricoh TotalFlow includes one or more input processing software modules (a first user input device) that receives input provided by a user to associate a “job setup” GUI object with a GUI object for a particular document, along with their respective data values stored in memory (selectively associating at least two of said first, second and third visual representations). The manner in which Ricoh TotalFlow meets this claim element is described in more detail below. As shown in the figure below, Ricoh TotalFlow creates a new job using three separate documents (e.g., “Aquatic book 13 pages,” “Aquatic book back cover,” and “Aquatic Book Cover.jpg”) selected by a user. In this fashion, input processing software modules of Ricoh TotalFlow receives user selections provided by a user.

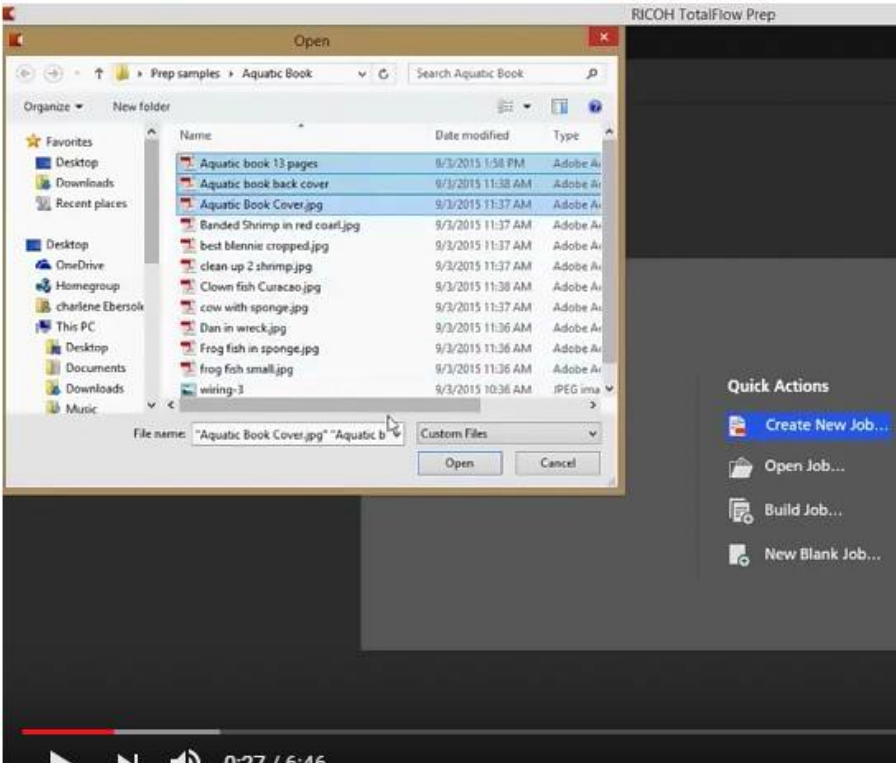

Ex. 28 (PDF of <https://www.youtube.com/watch?v=hk0oKHHrxi4&t=70s> (“TotalFlow Prep Booklets”)).

188. As shown in the figure below, Ricoh TotalFlow creates the new job using three separate documents selected by a user. As depicted below, visual representations of each specific document are visually paired with the newly created job (a second visual representation on said display) because their respective content (e.g., text, images) are displayed as part of the new job. The three separate documents can be combined to form a new single document that is associated with the new job. Accordingly, as depicted below, their respective content are considered to be individual pages (a third visual representation on said display). In this manner, the visual representations of each page can be (1) associated with the new document object created by the individual documents and (2) associated with the new job as a result of the initial user selection.

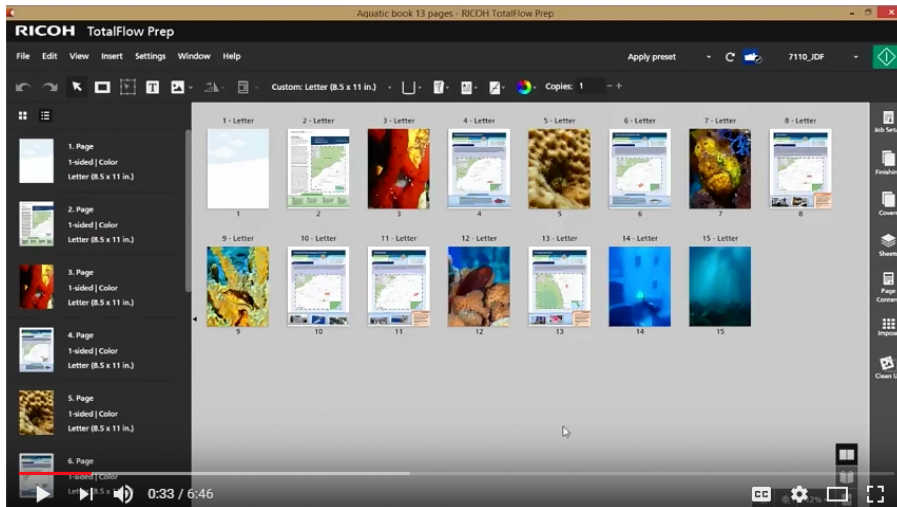

Ex. 28 (PDF of <https://www.youtube.com/watch?v=hk0oKHHrXI4&t=70s> (“TotalFlow Prep Booklets”)).

189. Claim limitation 1[f] is satisfied for at least the following reasons. Ricoh TotalFlow includes an input processing software module (a second input device) that receives input provided by a user to create “page view” attribute data within a region in memory resident within a computer that executes Ricoh TotalFlow (page object). The input processing software module enables the user to select a value for the page view attribute which is then applied to one or more pages within a document to be printed. As a result, the input processing software module of Ricoh TotalFlow associates the respective objects of the document and at least one page of the document with page objects when it prints the document based on the values set for the page.

190. As shown in the figure below, Ricoh TotalFlow creates page objects when it uses an input processing software module that receives character values for a particular page of a document (page attribute) that are provided by a user upon selection of a particular page attribute displayed on a GUI (second user input device operative to allow selection of said

page attribute, setting of a value of said page attribute and selection of one or more of said at least one page in said document to apply said page attribute).

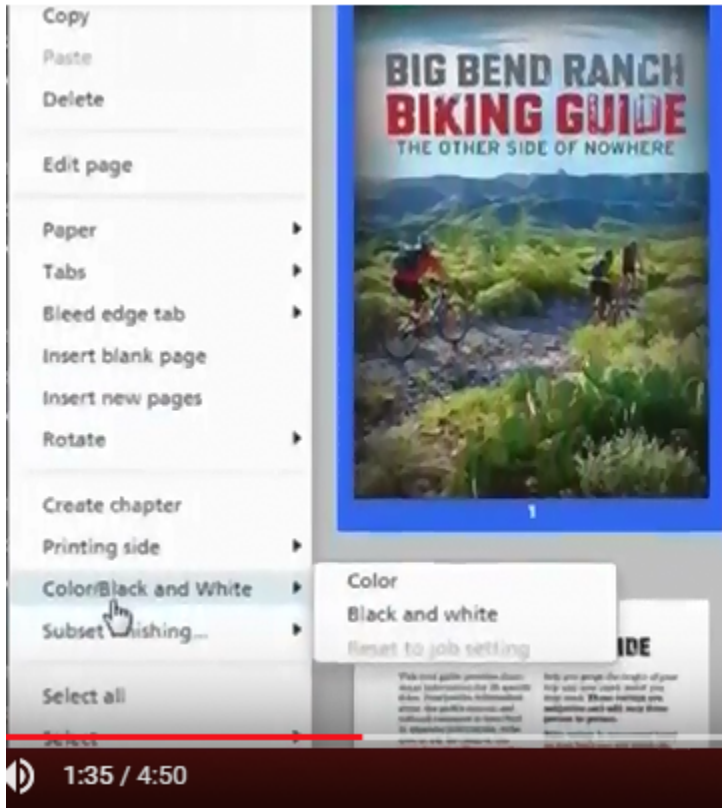

Ex. 26 (PDF of <https://www.youtube.com/watch?v=e9l73WVW61Y> (Ricoh TotalFlow Prep PODi Product Briefing)).

191. Ricoh TotalFlow stores data values that represent the “page view” attribute values of the page within a region in memory resident within a computer that executes Ricoh TotalFlow. In this fashion, these values, stored in memory, are linked to the page and document that includes the page (wherein upon application, one or more of said page objects are created and associated with each of said one or more of said at least one page and said corresponding document object).

192. Claim limitation 1[g] is satisfied for at least the following reasons. This limitation is satisfied whenever a document is launched since it visually displays the document

GUI object (the first visual representation on said display), the document's job ticket GUI objects (the second visual representation on said display), and the page GUI objects (the third visual representation on said display) all at the same time within the same display. In this fashion, when the document is launched, Ricoh TotalFlow associates the underlying objects of the document, the document's job ticket, and at least one page of the document by displaying their respective values along with the aforementioned GUIs.

193. As shown in the figure below, Ricoh TotalFlow associates the first, second and third visual representations whenever a document (e.g., "Big Bend Ranch Biking Guide") is loaded and displayed to a user. When the document is loaded, (1) the document's GUI object (the first visual representation on said display), (2) the document's job ticket GUI objects, i.e., the "job setup," "finishing," "covers," "sheets," "page content," and "impose" GUI objects (the second visual representation on said display), and (3) page GUI objects (the third visual representation on said display) are all visually displayed at the same time. Accordingly, Ricoh TotalFlow associates each of the respective objects when it displays the respective data values that represent each of the aforementioned GUI objects visually to the user. In this fashion, Ricoh TotalFlow uses identifiers (e.g., document IDs, page IDs, job IDs, and the like) stored in a database or memory structure to retrieve the aforementioned values.

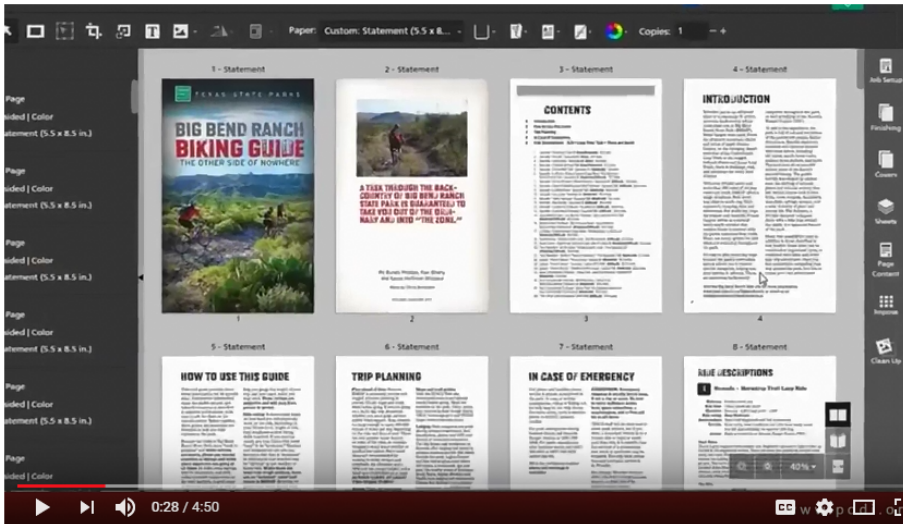

Ex. 26 (PDF of <https://www.youtube.com/watch?v=e9173WVW61Y> (Ricoh TotalFlow Prep PODi Product Briefing)).

194. Claim limitation 1[h] is satisfied for at least the following reasons. Ricoh TotalFlow generates graphics data to render a GUI object that displays page attribute values of a page. As shown in the figure below, applied page attribute values are displayed by Ricoh TotalFlow when it displays a page view of a particular page.

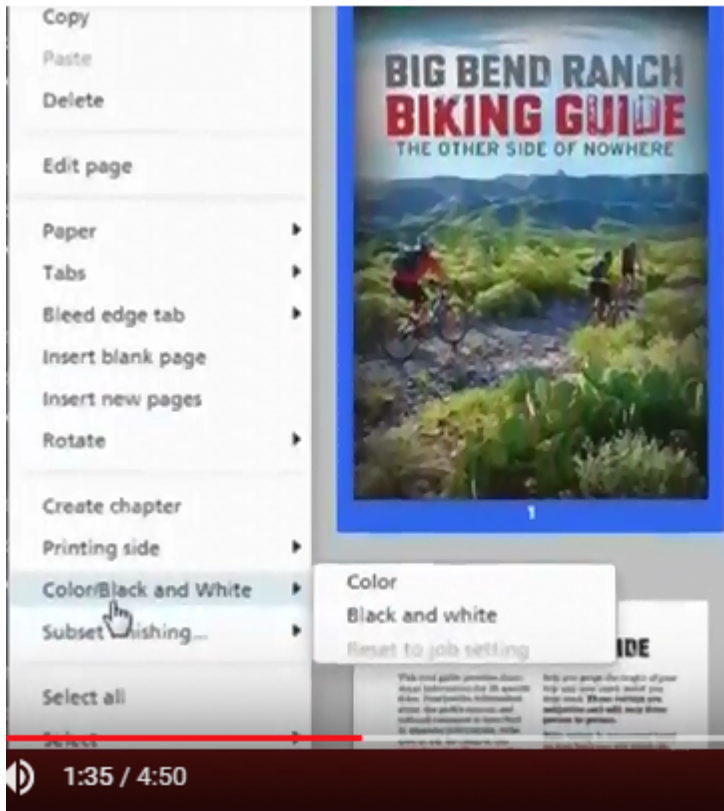

Ex. 26 (PDF of <https://www.youtube.com/watch?v=e9l73WVW61Y> (“Ricoh TotalFlow Prep PODi Product Briefing)).

195. Ricoh also infringes under the doctrine of equivalents because it meets at least, and by way of example, the following claim limitation(s) of representative Claim 1 by performing substantially the same function as this limitation, performing this function in substantially the same way as this limitation, and achieving substantially the same results as claim limitation 1[g]. For example, and without limitation, Ricoh TotalFlow performs substantially the same function in substantially the same way and achieves substantially the same result at least because it generates a display in which data values associated with the underlying objects of a document, the document’s job ticket, and at least one page of the document are displayed at the same time within the same display.

196. As a result of Defendant's unlawful activities, MASA has suffered and will continue to suffer irreparable harm for which there is no adequate remedy at law. Accordingly, MASA is entitled to preliminary and/or permanent injunctive relief.

197. Defendant's infringement of the '756 Patent has injured and continues to injure MASA in an amount to be proven at trial.

COUNT V

(Direct Infringement of the '974 Patent pursuant to 35 U.S.C. § 271(a))

198. MASA repeats, realleges, and incorporates by reference, as if fully set forth herein, the allegations of the preceding paragraphs, as set forth above.

199. Defendant has infringed and continues to infringe one or more claims of the '974 Patent, including at least claim 1, in violation of 35 U.S.C. § 271(a).

200. Defendant's infringement is based upon literal infringement or infringement under the doctrine of equivalents, or both.

201. Defendant's acts of making, using, importing, selling, and/or offering for sale infringing products and services have been without the permission, consent, authorization, or license of MASA.

202. Defendant's infringement includes the manufacture, use, sale, importation and/or offer for sale of Defendant's products and services, such as Ricoh ProcessDirector system.

203. Claim 1 of the '974 Patent is recited below:

A method for providing production printing instructions relating to a printed end document to a job preparation station, wherein the printed end document comprises a plurality of documents in a predefined order, the plurality of documents each comprising content and document formatting, the method comprising:

1[a] receiving the plurality of documents in electronic format from a job submission station operator, and

1[b] transmitting the documents in electronic format to a computer;

- 1[c] placing said plurality of documents into an electronic folder in the computer;
- 1[d] arranging the plurality of documents in said folder in the order the documents are to be printed in the printed end document;
- 1[e] said computer automatically converting the plurality of documents into a ready for printer format and merging the plurality of documents together to create a single document in said ready for printer format where the plurality of documents comprise a main portion and at least one exception page;
- 1[f] delaying the printing of the main portion at a production device associated with the single document, while the at least one exception page is printed at an alternate output device;
- 1[g] receiving at the production device the at least one exception page from the alternate output device;
- 1[h] printing at the production device the main portion and where the production device collates the at least one exception page with the main portion; and
- 1[i] said computer automatically creating an electronic job ticket providing global attributes for the printed end document.

204. As one example of how the '974 Accused Products infringe at least claim 1, Ricoh ProcessDirector meets the limitations of claim 1 of the '974 Patent for at least the reasons described below.

205. As a general matter and as explained below, the limitations of claim 1 are satisfied. Ricoh ProcessDirector provides a method that communicates printing instructions to different printing and finishing devices. Printed documents produced using the method provided by Ricoh ProcessDirector can include multiple, user-selected documents that are merged to form a single document for printing. The single document for printing includes content, such as text, images, etc., and can be formatted in accordance with user preferences.

206. For instance, as shown in the excerpt below, Ricoh ProcessDirector provides a method when it communicates with different types of devices, both Ricoh devices and third-

party devices using drivers.

Print Services Facility™ (PSF) print driver
 Run jobs on Ricoh, third-party and Intelligent Printer Data Stream™ (IPDS™) printers from within RICOH ProcessDirector. A world-class print driver allows you to send jobs reliably to the printer of your choice and take advantage of IPDS' bi-directional communication and robust error recovery.

Access to third-party programs
 Include other programs, like composition, page formatting and document manipulation software, in your print workflow process. They can be installed on the RICOH ProcessDirector server or on remote Windows, AIX or Linux servers and controlled easily from within the workflow builder.

Ricoh Ex. 29 (ProcessDirector.pdf at page 1).

207. As shown in the figure below, the method performed by Ricoh ProcessDirector provides an “assemble” section on a graphical user interface so that selected documents can be arranged in an order, specified by a user, for printing.

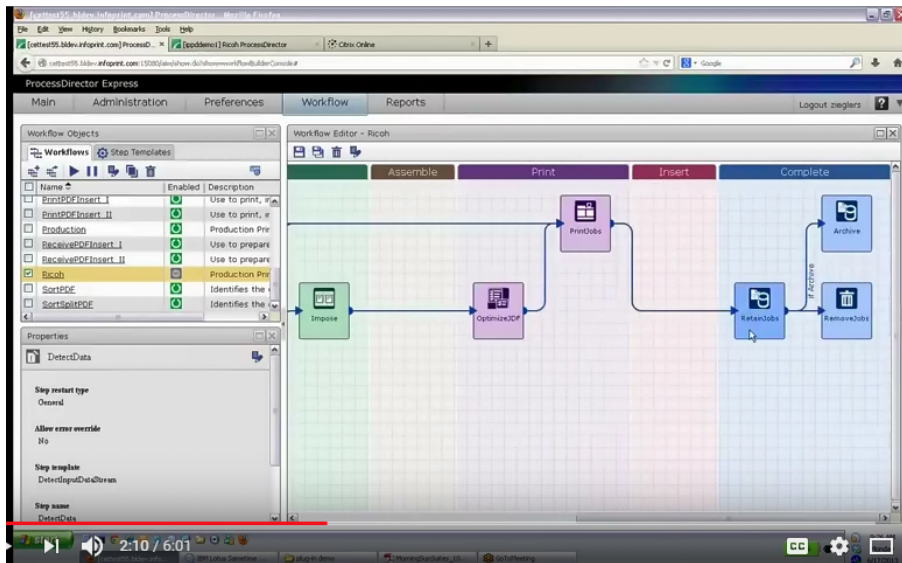

Ex. 30 (PDF of <https://www.youtube.com/watch?v=6i1MFwdYiPk> (RICOH ProcessDirector Express PODi Product Briefing -- Part 3 Workflow Builder Demo)).

208. In addition, as shown in the table below, the method performed by Ricoh ProcessDirector processes documents that include content and images including PDFs, AFPs, GIFs, TIFs, SAPs, JPGs PCLs, PostScripts, Metacode, etc. for a print job.

Submission methods:	<ul style="list-style-type: none"> • LPR • File copy or FTP to hot folders via file copy or FTP • Multipurpose Internet Mail Extensions (MIME) package (PDF/JDF) • z/OS® AFP Download Plus (RICOH ProcessDirector only) • Download for z/OS (RICOH ProcessDirector only)
Available transforms:	<ul style="list-style-type: none"> • Standard Adobe PDF • AFP • GIF • TIF • SAP • JPEG • PCL • PostScript® • Metacode (requires InfoPrint XT) print data

Ex. 31 (Ricoh ProcessDirector, Express Brochure (English) MR_t_223-87001.pdf at page 3).

209. Furthermore, as shown in the figure below, once assembled, the method performed by Ricoh ProcessDirector merges the documents together to create a single document in a format that is ready to be processed by a printer.

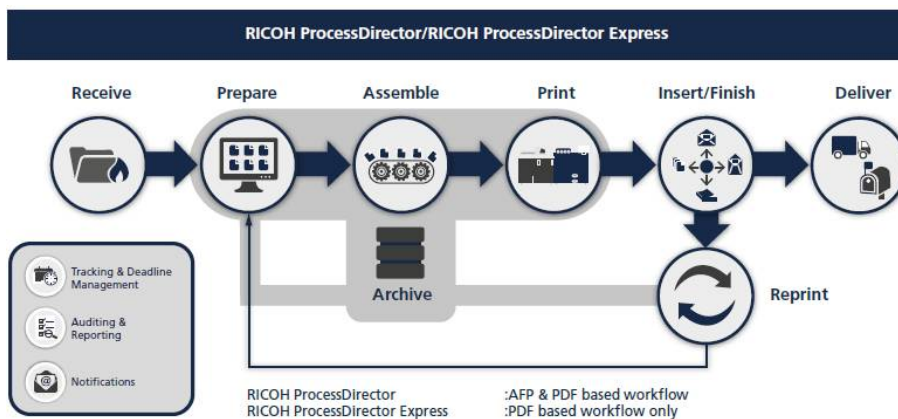

Ex. 31 (Ricoh ProcessDirector, Express Brochure (English) MR_t_223-87001.pdf at page 3).

210. Claim limitation 1[a] is satisfied for at least the following reasons. Ricoh ProcessDirector includes a receiver to receive the plurality of documents in electronic format. Ricoh ProcessDirector includes software components that are configured to receive electronic documents from computer memory ((e.g., hard disk memory, random-access memory, dynamic random-access memory , solid state drive(s)). The documents are placed in computer memory

by a user (from a job submission station operator). The receiver is disposed at a job submission station because the receiver software components reside in the computer executing ProcessDirector. The receiver is connected to transmit the documents in electronic format to the computer because the receiver software components retrieves electronic documents from computer memory and provides the documents to other software components of Ricoh ProcessDirector in order to process a job.

211. As shown in the figure below, Ricoh ProcessDirector uses software receiver components to retrieve electronic documents from computer memory so that a job can be processed by other components of Ricoh ProcessDirector.

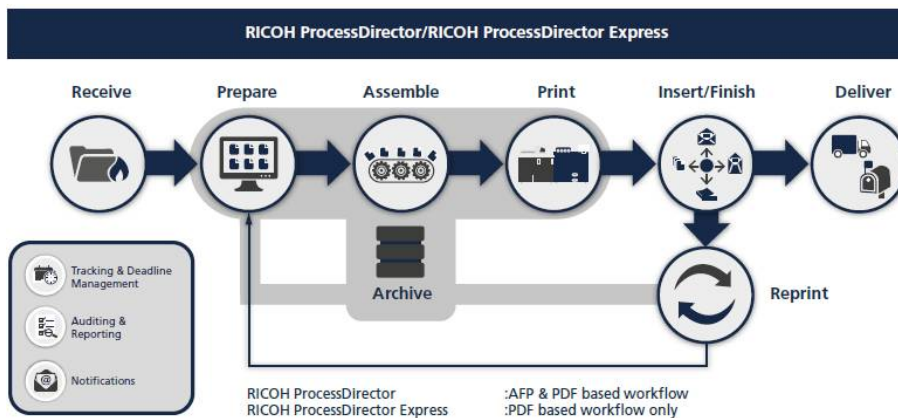

Ex. 31 (Ricoh ProcessDirector, Express Brochure (English) MR_t_223-87001.pdf at page 3).

212. As shown in the figure below, the drag and drop functionality provided by graphical user interfaces of Ricoh ProcessDirector enables the software receiver components to receive documents from a user (job submission station operator).

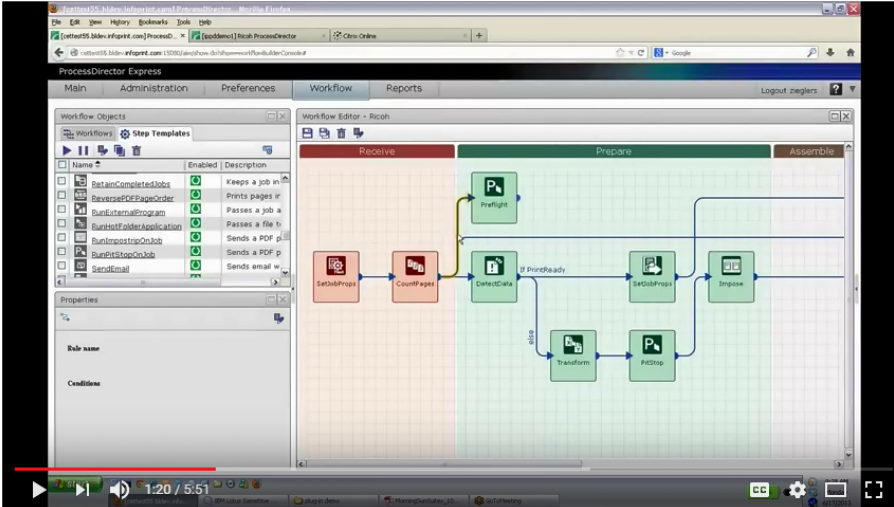

Ex. 32 (PDF of <https://www.youtube.com/watch?v=IGQBZEUaqgY> (RICOH ProcessDirector Express PODi Product Briefing -- Part I Overview)).

213. As shown in the table below, the different submission methods (e.g., file copy, internet mail) provided by Ricoh ProcessDirector enables the software receiver components to receive documents from a user (job submission station operator). As also shown below, documents include PDFs, GIFs, TIFs, JPEGs, etc.

<p>Submission methods:</p>	<ul style="list-style-type: none"> • LPR • File copy or FTP to hot folders via file copy or FTP • Multipurpose Internet Mail Extensions (MIME) package (PDF/JDF) • z/OS® AFP Download Plus (RICOH ProcessDirector only) • Download for z/OS (RICOH ProcessDirector only)
<p>Available transforms:</p>	<ul style="list-style-type: none"> • Standard Adobe PDF • AFP • GIF • TIF • SAP • JPEG • PCL • PostScript® • Metacode (requires InfoPrint XT) print data

Ex. 31 (Ricoh ProcessDirector, Express Brochure (English) MR_t_223-87001.pdf at page 3).

214. Claim limitation 1[b] is satisfied for at least the following reasons. As shown below, Ricoh ProcessDirector includes software receiver components that transmit the documents in electronic format to a computer. The receiver software components retrieve

electronic documents from computer memory and provide the documents to other software components of Ricoh ProcessDirector in order to process a job. As shown in the figure below, Ricoh ProcessDirector uses software receiver components to transmit electronic documents received from computer memory so that a job can be processed by other components of Ricoh ProcessDirector.

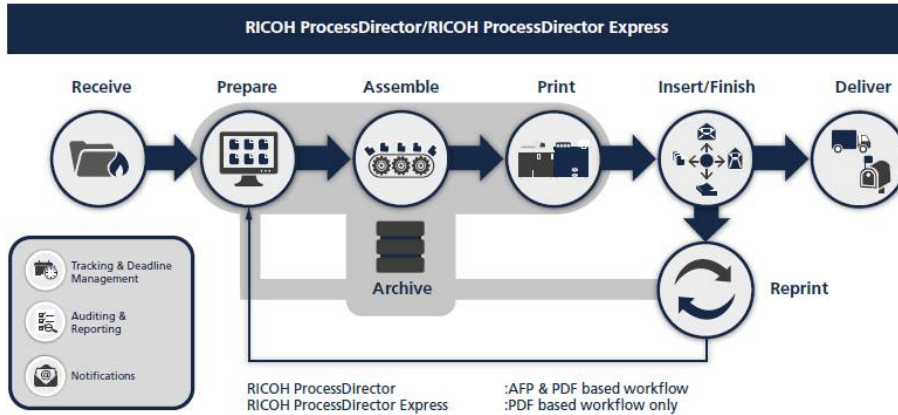

Ex. 31 (Ricoh ProcessDirector, Express Brochure (English) MR_t_223-87001.pdf at page 3).

215. As shown in the table below, the different submission methods (e.g., file copy, internet mail) provided by Ricoh ProcessDirector enables the software receiver components to receive documents from a user (job submission station operator) for transmission. Also, as shown in the figure below, documents include PDFs, GIFs, TIFs, JPEGs, etc.

<p>Submission methods:</p>	<ul style="list-style-type: none"> • LPR • File copy or FTP to hot folders via file copy or FTP • Multipurpose Internet Mail Extensions (MIME) package (PDF/JDF) • z/OS® AFP Download Plus (RICOH ProcessDirector only) • Download for z/OS (RICOH ProcessDirector only)
<p>Available transforms:</p>	<ul style="list-style-type: none"> • Standard Adobe PDF • AFP • GIF • TIF • SAP • JPEG • PCL • PostScript® • Metacode (requires InfoPrint XT) print data

Ex. 31 (Ricoh ProcessDirector, Express Brochure (English) MR_t_223-87001.pdf at page 3).

216. Claim limitation 1[c] is satisfied for at least the following reasons. Ricoh ProcessDirector enables a user to organize documents, within a particular section of a graphical user interface (electronic folder), in an order that is desirable to a user for a print job. For instance, as shown in the figure below, Ricoh ProcessDirector provides an “assemble” section on a graphical user interface which is a virtual location (electronic folder) to place the documents. Within this “assemble” section, the documents are arranged in an order, specified by a user, to be printed.

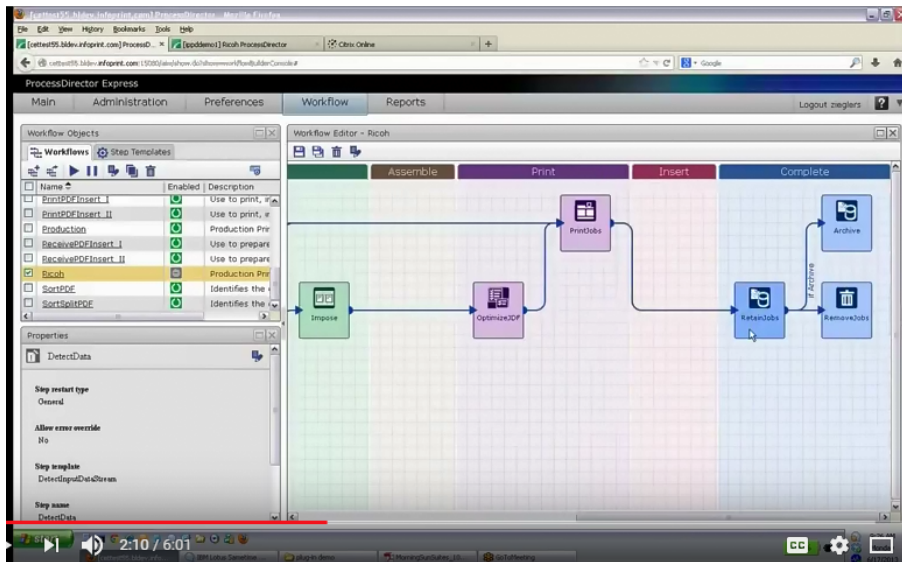

Ex. 30 (PDF of <https://www.youtube.com/watch?v=6i1MFwdYiPk> (RICOH ProcessDirector Express PODi Product Briefing -- Part 3 Workflow Builder Demo)).

217. Claim limitation 1[d] is satisfied for at least the following reasons. Ricoh ProcessDirector enables a user to organize documents, within a particular section of a graphical user interface (electronic folder), in an order that is desirable to a user for a print job. For instance, as shown in the figure below, Ricoh ProcessDirector provides an “assemble” section on a graphical user interface which is a virtual location (folder) to place the

documents. Within this “assemble” section, the documents are arranged in an order, specified by a user, to be printed.

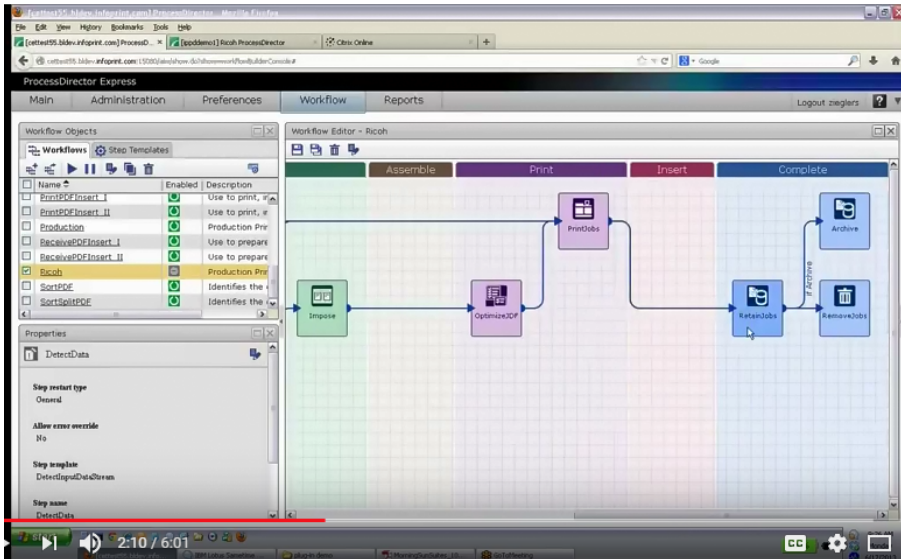

Ex. 30 (<https://www.youtube.com/watch?v=6i1MFwdYiPk> (RICOH ProcessDirector Express PODi Product Briefing -- Part 3 Workflow Builder Demo)).

218. Claim limitation 1[e] is satisfied for at least the following reasons. Ricoh ProcessDirector automatically transforms documents into a printer ready format before they are submitted to a printer. The ready for printer format includes a main portion and at least one exception page that includes content produced separate to the main portion. For instance, as shown in the figure below, Ricoh ProcessDirector provides an “assemble” section on a graphical user interface which is a virtual location (folder) to place the documents. Within this “assemble” section, the documents are arranged in an order, specified by a user, to be printed.

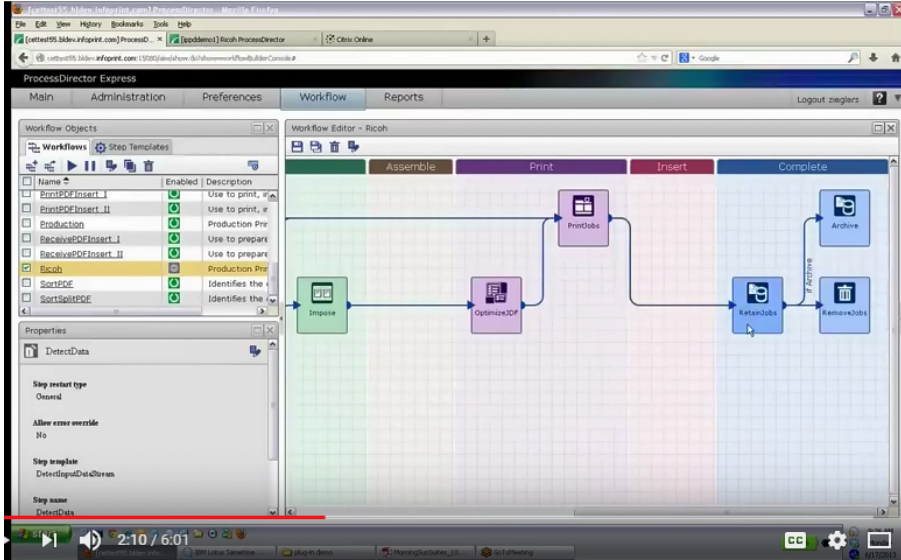

Ex. 30 (<https://www.youtube.com/watch?v=6i1MFwdYiPk> (RICOH ProcessDirector Express PODi Product Briefing -- Part 3 Workflow Builder Demo)).

219. In addition, as shown in the table below, Ricoh ProcessDirector performs transforms that automatically converts documents into PDFs, AFPs, GIFs, TIFs, SAPs, JPGs PCLs, PostScripts, Metacode, etc. for a print job (ready for printer format).

Submission methods:	<ul style="list-style-type: none"> • LPR • File copy or FTP to hot folders via file copy or FTP • Multipurpose Internet Mail Extensions (MIME) package (PDF/JDF) • z/OS® AFP Download Plus (RICOH ProcessDirector only) • Download for z/OS (RICOH ProcessDirector only)
Available transforms:	<ul style="list-style-type: none"> • Standard Adobe PDF • AFP • GIF • TIF • SAP • JPEG • PCL • PostScript® • Metacode (requires InfoPrint XT) print data

Ex. 31 (Ricoh ProcessDirector, Express Brochure (English) MR_t_223-87001.pdf at page 3).

220. Furthermore, as shown in the figure below, once assembled, Ricoh ProcessDirector merges the documents together to create a single document in a format that is ready to be processed by a printer.

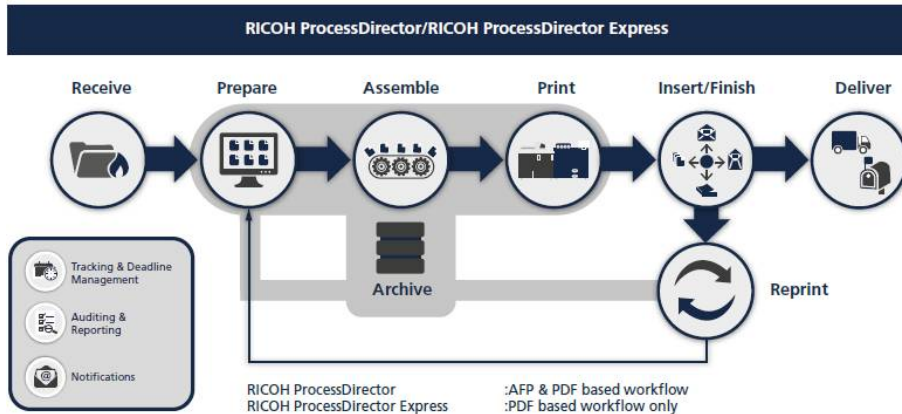

Ex. 31 (Ricoh ProcessDirector, Express Brochure (English) MR_t_223-87001.pdf at page 3).

221. Moreover, as shown in the excerpt below, Ricoh ProcessDirector includes the functionality to produce exception pages and main portions.

Further, with this feature, you can boost efficiency by bringing together data, logic and finishing. Use the RICOH ProcessDirector Acrobat plug-in to set up finishing rules visually. Imagine mining information, such as a recipient's name or club member status, from a multi-document print job and dynamically setting up the paper on which it prints. Or, what if you could easily find the document boundaries within a print job? Then, for example, if a document is greater than a certain number of pages, direct it to be perfect bound, and direct documents with fewer pages to be stapled. Or, set up subset stapling and logic-based media substitutions based on a sample file, and then automatically apply those rules every time that type of work comes through RICOH ProcessDirector.

Ex. 29 (Ricoh ProcessDirector.pdf at page 3).

222. Claim limitation 1[f] is satisfied for at least the following reasons. Ricoh ProcessDirector performs procedures that delay the performance of the printer producing the main portion of a document, while the finisher produces the one or more exception pages. As shown in the excerpt below, the plurality of documents include a main portion (e.g., documents that are greater than a certain number of pages) and at least one exception page (e.g., documents that are less than a certain number of pages). Using “rules,” Ricoh ProcessDirector enables (1) the main portion to be delayed at the production device, while exception pages are printed at the alternate output device and (2) the production device to collate the main portion with exception pages.

Further, with this feature, you can boost efficiency by bringing together data, logic and finishing. Use the RICOH ProcessDirector Acrobat plug-in to set up finishing rules visually. Imagine mining information, such as a recipient's name or club member status, from a multi-document print job and dynamically setting up the paper on which it prints. Or, what if you could easily find the document boundaries within a print job? Then, for example, if a document is greater than a certain number of pages, direct it to be perfect bound, and direct documents with fewer pages to be stapled. Or, set up subset stapling and logic-based media substitutions based on a sample file, and then automatically apply those rules every time that type of work comes through RICOH ProcessDirector.

Ex. 29 (Ricoh ProcessDirector.pdf at page 3).

223. Claim limitation 1[g] is satisfied for at least the following reasons. Ricoh ProcessDirector performs procedures that enable it to receive, at a printer device, exception pages that are produced at a different device, such as a finisher device. As shown in the excerpt below, the plurality of documents include a main portion (e.g., documents that are greater than a certain number of pages) and at least one exception page (e.g., documents that are less than a certain number of pages). Using “rules,” Ricoh ProcessDirector can configure a printer device to receive exception pages that were prepared by an alternate output device.

Further, with this feature, you can boost efficiency by bringing together data, logic and finishing. Use the RICOH ProcessDirector Acrobat plug-in to set up finishing rules visually. Imagine mining information, such as a recipient's name or club member status, from a multi-document print job and dynamically setting up the paper on which it prints. Or, what if you could easily find the document boundaries within a print job? Then, for example, if a document is greater than a certain number of pages, direct it to be perfect bound, and direct documents with fewer pages to be stapled. Or, set up subset stapling and logic-based media substitutions based on a sample file, and then automatically apply those rules every time that type of work comes through RICOH ProcessDirector.

Ex. 29 (Ricoh ProcessDirector.pdf at page 3).

224. Claim limitation 1[h] is satisfied for at least the following reasons. Ricoh ProcessDirector performs procedures that enable it to print, at a printer device, the main portions of document and also collate exception pages with the main portion. As shown in the excerpt below, Ricoh ProcessDirector can configure the printer device to print a main portion of a document and a document and correlate those documents.

Collating the Job Copies

Specifies how to collate the copies of the job.

To specify how to collate the copies:

1. Click **[Finishing]** on the left side of the screen.
2. Select **[Shift collate]** to stack all the pages of the first set of copies in the bin, and then jog to offset the stack before stacking all the pages of the second set of copies in the output bin.
3. To set the number of copies you want stacked in each set, enter a value in the **[Stack interval]** field.
4. Select **[Collate]** to sort all the pages of the first copy in the bin, followed by all the pages of the second copy.
5. Select **[Stack]** to sort all the copies of the first set of pages in the bin, and then jog to offset the stack before stacking all the copies of the second set of pages in the output bin.
6. To set the number of copies you want stacked in each set, enter a value in the **[Stack interval]** field.
7. Select **[Off]** to sort all the copies of the first page in the bin, followed by all the copies of the second page.

Ex. 33 (M2737502_en.pdf at page 128).

225. In addition, as shown in the excerpt below, the plurality of documents include a main portion (e.g., documents that are greater than a certain number of pages) and at least one exception page (e.g., documents that are less than a certain number of pages). Using “rules” Ricoh ProcessDirector can co (1) the main portion to be delayed at the production device, while exception pages are printed at the alternate output device and (2) the production device to collate the main portion with exception pages.

Further, with this feature, you can boost efficiency by bringing together data, logic and finishing. Use the RICOH ProcessDirector Acrobat plug-in to set up finishing rules visually. Imagine mining information, such as a recipient's name or club member status, from a multi-document print job and dynamically setting up the paper on which it prints. Or, what if you could easily find the document boundaries within a print job? Then, for example, if a document is greater than a certain number of pages, direct it to be perfect bound, and direct documents with fewer pages to be stapled. Or, set up subset stapling and logic-based media substitutions based on a sample file, and then automatically apply those rules every time that type of work comes through RICOH ProcessDirector.

Ex. 29 (Ricoh ProcessDirector.pdf at page 3).

226. Claim limitation 1[i] is satisfied for at least the following reasons. As shown below, Ricoh ProcessDirector enables a user to create an electronic job ticket that includes global attributes for a document to be printed. As shown in the figure below, Ricoh

ProcessDirector creates an electronic job ticket because the work flows created by Ricoh ProcessDirector include job instructions for how the documents are to be printed.

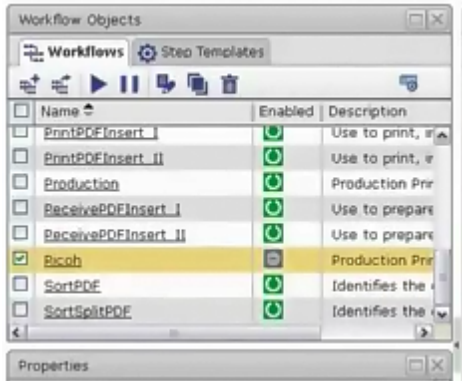

Ex. 30 (PDF of <https://www.youtube.com/watch?v=6i1MFwdYiPk> (RICOH ProcessDirector Express PODi Product Briefing -- Part 3 Workflow Builder Demo)).

227. As shown in the excerpt below, the electronic job tickets includes global attributes for the printed end document since the logic-based tools enable Ricoh ProcessDirector apply media, finishing and binding requirements to every document of a print job.

Document-level print management

After you use logic-based tools to set up the media, finishing, and binding requirements for every document, RICOH ProcessDirector can use this knowledge to further improve productivity. For example, all the documents to be bound can be peeled out of the job and run separately and on a different time table.

Ex. 29 (Ricoh ProcessDirector.pdf at page 3).

228. Ricoh also infringes under the doctrine of equivalents because it meets at least, and by way of example, the following claim limitation (s) of representative Claim 1 by performing substantially the same function as this limitation, performing this function in substantially the same way as this limitation and achieving substantially the same results as claim limitation 1[h]. For example, and without limitation, Ricoh ProcessDirector performs

substantially the same function in substantially the same way and achieves substantially the same result at least because it produces a printed end document by coordinating (1) the functionality of a production device to produce a main portion of the printed end document and (2) the functionality of an alternative device to produce an exception portion of the printed end document.

229. As a result of Defendant's unlawful activities, MASA has suffered and will continue to suffer irreparable harm for which there is no adequate remedy at law. Accordingly, MASA is entitled to preliminary and/or permanent injunctive relief.

230. Defendant's infringement of the '974 Patent has injured and continues to injure MASA in an amount to be proven at trial.

COUNT VI

(Direct Infringement of the '269 Patent pursuant to 35 U.S.C. § 271(a))

231. MASA repeats, realleges, and incorporates by reference, as if fully set forth herein, the allegations of the preceding paragraphs, as set forth above.

232. Defendant has infringed and continues to infringe one or more claims of the '269 Patent, including at least claim 1, in violation of 35 U.S.C. § 271(a).

233. Defendant's infringement is based upon literal infringement or infringement under the doctrine of equivalents, or both.

234. Defendant's infringement includes the manufacture, use, sale, importation and/or offer for sale of Defendant's products and services, such as Ricoh Pro C7100/C7100x/C7110/C7110x

235. Claim 1 of the '269 Patent is recited below:

An improved method of operating a feeder of sheets that comprises the steps:

1[a] moving a sheet from a sheet supply stack to a first position; moving the sheet to a second position; the improvement comprising:

1[b] moving the sheet at least partially from the sheet supply stack;

1[c] replacing the sheet on the sheet supply stack,

1[d] wherein the improved steps are carried out for the purpose of loosening the sheet from the sheet supply stack to insure that only one sheet is moved to the second position, and are carried out at a time when the known steps are not in process.

236. As one example of how the '269 Accused Products infringe at least claim 1,

Ricoh Pro C7100X meets the limitations of claim 1 of the '269 Patent for at least the following reasons.

237. An image of Ricoh Pro C7100 is provided below:

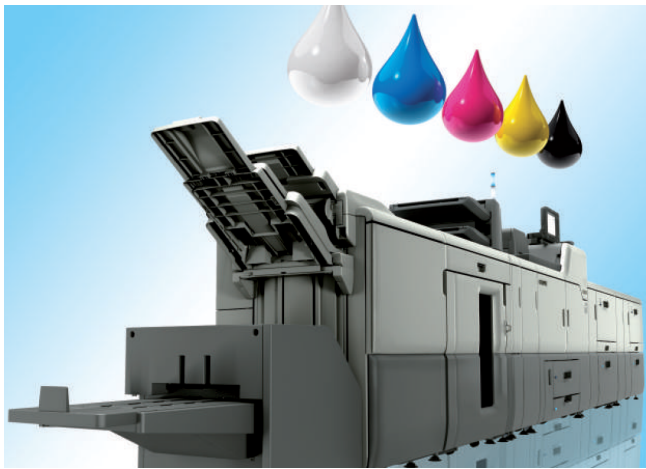

238. As a general matter and as described below, the limitations of claim 1 are satisfied because Ricoh Pro C7100X performs an improved method of operating a feeder of sheets.

239. Claim limitation 1[a] is satisfied for at least the following reasons. As shown below, Ricoh Pro C7100X includes Pro Printers, which are production print systems that operate a sheet feeder (e.g., the vacuum feed LCIT RT5100). The sheet feeding process includes moving a sheet from a paper stack from one position (e.g., the sheet's original, unfed position) to another position (e.g., a fed position).

In this manual, major features of the machine are referred to as follows:

- Auto Document Feeder → ADF
- Multi Bypass Tray BY5010 → Multi bypass tray (Tray A)
- Wide Large Capacity Tray → Wide LCT (in this manual, "wide LCT" refers to the three-tray wide LCT and the two-tray wide LCT)
- LCIT RT5090 → Three-tray wide Large Capacity Tray (Three-tray wide LCT)
- Vacuum Feed LCIT RT5100 → Two-tray wide Large Capacity Tray (Two-tray wide LCT)
- Multi-Folding Unit FD5020 → Multi-folding unit
- Decurl Unit DU5040 → Decurl unit
- Buffer Pass Unit Type S3 → Buffer pass unit
- Ring Binder RB5020 → Ring binder
- High Capacity Stacker SK5030 → High capacity stacker
- Trimmer Unit TR5040 → Trimmer
- Cover Interposer Tray CI5030 → Interposer
- Perfect Binder GB5010 → Perfect binder
- Tab Sheet Holder Type 3260 → Tab sheet holder

Ex. 34 (Pro C7100/C7100x/C7110/C7110x User Guide (2014))

240. Claim limitation 1[b] is satisfied for at least the following reasons. As shown below, Ricoh Pro C7100X includes a sheet feeder (e.g., the vacuum feed LCIT RT5100) that provides airflow for separating sheets in a stack as shown below. Pro Printers comprise large capacity input tray which holds a stack of paper sheets and uses the sheet feeder to move the sheet from the sheet supply stack through the printer.

Two-tray wide LCT (Vacuum Feed LCIT RT5100) is used.

The factory-set airflow of the wide LCT may not be strong enough to separate the sheets.

Increase the airflow.

1. In [Advanced Settings] for the custom paper you are using, set 118: [Paper Feed Mode (Adjust Fan Level)] to [Moderate Dble Fd Red. (Lower)].
2. If the problem persists, set 118: [Paper Feed Mode (Adjust Fan Level)] to [Max Dble Fd Reduc. (Lowest)].
3. If the problem persists, increase the value in 112: [Blower Fan] by 10%.
4. If the problem persists, increase the value an additional 10% in 112: [Blower Fan].
5. If the problem persists, set 117: [Switch Paper Load Upper Limit] to [Low].

Ex 35 (Ricoh trouble shooting.pdf)



The three belt Vacuum Feed RT5100 reliably feeds media up to 360 g/m². Connect up to three units to increase your paper capacity to 16,200 sheets. Feeds colored and clear media.

Ex 36 (RICOH Pro C7100X)

241. Claim limitation 1[c] is satisfied for at least the following reasons. Ricoh Pro C7100X replaces the sheet on the sheet supply stack and the sheet is delivered by the belt to the printing unit as shown below:



Vacuum Paper Feed, Large Capacity Input Tray (LCIT) and Bridge Unit (Option)

- Air vacuum feature allows handling of more heavy media with coated surface
- Supports media weight (mainframe-specific) 52 gsm to 360 gsm
- Delivers air to front and sides so each sheet can be delivered by the belt separately
- Offers high level of feeding accuracy for greater productivity for a wide variety of media types and weight
- Up to three units can be attached to the main frame
- Maximum capacity of each tray is 2,200 sheets (80 gsm)
- Maximum capacity per unit is 4,400 sheets (80 gsm)

Banner Sheet Tray (Option)

- Optionally integrated to the upper tray of the Vacuum Paper Feed
- Paper size: 210 - 330 mm x 420 - 700 mm
- Media weight: 52 - 300 gsm
- Up to 1,250 sheet capacity dependent on media thickness
- Tray to support Banner Sheet for the Finisher included

Multi-Bypass Tray (Option)

- The multi-bypass unit has banner sheet tray as an option
- Paper size: 210 - 330 mm x 420 - 1260 mm
- Media weight: 52 - 216 gsm
- Up to 500 sheet capacity dependent on media thickness



Ex 36 (RICOH Pro C7100X).

242. Claim limitation 1[d] is satisfied for at least the following reasons. Airflow is provided by the vacuum feed LCIT RT5100 of Ricoh Pro C7100X which loosens sheets to ensure that only a single sheet is fed during sheet feeding as shown below.

Two-tray wide LCT (Vacuum Feed LCIT RT5100) is used.

The factory-set airflow of the wide LCT may not be strong enough to separate the sheets.

Increase the airflow:

1. In [Advanced Settings] for the custom paper you are using, set 118: [Paper Feed Mode (Adjust Fan Level)] to [Moderate Dble Fd Red. (Lower)].
2. If the problem persists, set 118: [Paper Feed Mode (Adjust Fan Level)] to [Max Dble Fd Reduc. (Lowest)].
3. If the problem persists, increase the value in 112: [Blower Fan] by 10%.
4. If the problem persists, increase the value an additional 10% in 112: [Blower Fan].
5. If the problem persists, set 117: [Switch Paper Load Upper Limit] to [Low].

Ex. 35 (Ricoh trouble shooting.pdf).



Vacuum Paper Feed, Large Capacity Input Tray (LCIT) and Bridge Unit (Option)

- Air vacuum feature allows handling of more heavy media with coated surface
- Supports media weight (mainframe-specific) 52 gsm to 360 gsm
- Delivers air to front and sides so each sheet can be delivered by the belt separately
- Offers high level of feeding accuracy for greater productivity for a wide variety of media types and weight
- Up to three units can be attached to the main frame
- Maximum capacity of each tray is 2,200 sheets (80 gsm)
- Maximum capacity per unit is 4,400 sheets (80 gsm)

Banner Sheet Tray (Option)

- Optionally integrated to the upper tray of the Vacuum Paper Feed
- Paper size: 210 - 330 mm x 420 - 700 mm
- Media weight: 52 - 300 gsm
- Up to 1,250 sheet capacity dependent on media thickness
- Tray to support Banner Sheet for the Finisher included

Multi-Bypass Tray (Option)

- The multi-bypass unit has banner sheet tray as an option
- Paper size: 210 - 330 mm x 420 - 1260 mm
- Media weight: 52 - 216 gsm
- Up to 500 sheet capacity dependent on media thickness



Ex 35 (Ricoh trouble shooting.pdf)

243. Ricoh also infringes under the doctrine of equivalents because it meets at least, and by way of example, the following claim limitation (s) of representative Claim 1 by performing substantially the same function as this limitation, performing this function in substantially the same way as this limitation, and achieving substantially the same results as claim limitation1[d]. For example, and without limitation, Ricoh Pro C7100X perform substantially the same function in substantially the same way and achieves substantially the same result at least because they move sheets of paper within a supply of paper to loosen the top most sheet from the supply of paper in the same way and the achieve the substantially the same result as the recited claim language.

244. As a result of Defendant's unlawful activities, MASA has suffered and will continue to suffer irreparable harm for which there is no adequate remedy at law. Accordingly, MASA is entitled to preliminary and/or permanent injunctive relief.

245. Defendant's infringement of the '269 Patent has injured and continues to injure MASA in an amount to be proven at trial.

COUNT VII

(Direct Infringement of the '285 Patent pursuant to 35 U.S.C. § 271(a))

246. MASA repeats, realleges, and incorporates by reference, as if fully set forth herein, the allegations of the preceding paragraphs, as set forth above.

247. Defendant has infringed and continues to infringe one or more claims of the '285 Patent, including at least claim 1, in violation of 35 U.S.C. § 271(a).

248. Defendant's infringement is based upon literal infringement or infringement under the doctrine of equivalents, or both.

249. Defendant's acts of making, using, importing, selling, and/or offering for sale infringing products and services have been without the permission, consent, authorization, or license of MASA.

250. Defendant's infringement includes the manufacture, use, sale, importation and/or offer for sale of Defendant's products and services, such as Ricoh PM and TCRU, including at least the following models: Pro C5200S/C5210S, Pro C901S, Pro C901, Pro C900s, Pro C900, and Aficio SP C410DN.

251. Claim 1 of the '285 Patent is recited below:

A system with operator enabled maintenance comprising:

1[a] at least one computational element within said system

1[b] a plurality of operator replaceable component (ORC) devices within said system, each of said ORC devices having an expected life span;

1[c] a use mechanism coupled to each said computational element and said ORC devices, said use mechanism tracking use of at least one of said ORC devices using a predetermined parameter;

1[d] a comparison mechanism that compares use of said ORC devices to said expected life span; and

1[e] an operator alert mechanism responsive to said comparison mechanism to provide said operator alert when the result of said comparison satisfies a predetermined parameter representing at least one of said expected life spans where said expected life span for a single of said ORC devices is the shortest expected life span.

252. As one example of how the '285 Accused Products infringe at least claim 1, Ricoh PM and TCRU meets the limitations of claim 1 of the '285 Patent for at least the reasons described below.

253. As a general matter and as explained below, the limitations of claim 1 are satisfied because Ricoh PM and TCRU is a multifunction printer that includes a Ricoh PM and TCRU unit that meet the recited claim language because the control panels of Ricoh PM and TCRU units provide several user tools for operators to perform maintenance. As shown below, the control panel includes a selectable maintenance option for operator enabled maintenance.

1. Press the [User Tools] key on the control panel.

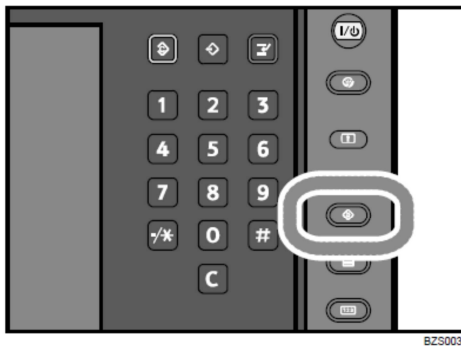

2. Press [System Settings] on the display.

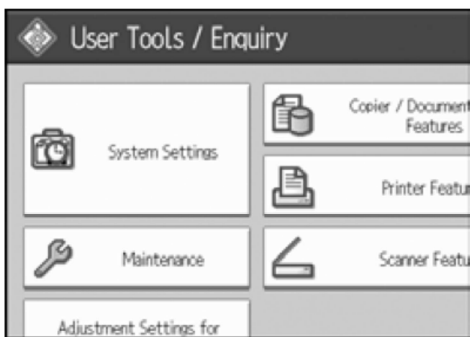

2.3 Displaying the [Adjustment Settings for Skilled Operators] Button

7. Select [On] for "Admin. Authentication".

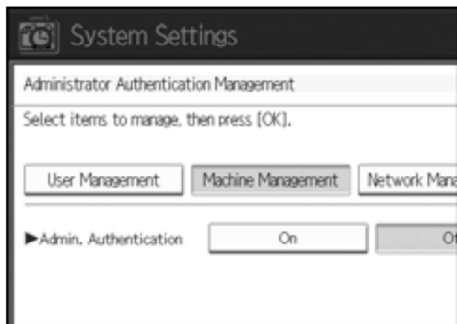

8. Press [OK].
9. Press [Exit].

The [Adjustment Settings for Skilled Operators] button appears.

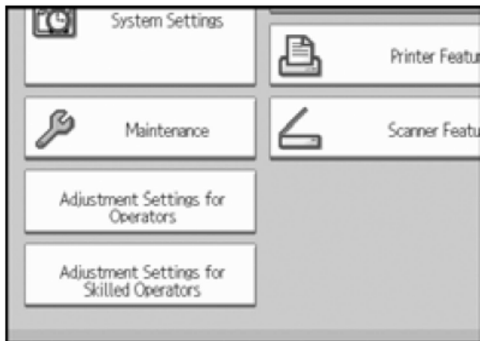

Ex. 37 (rfg.pdf, pp. 16-17 and steps 1, 2, 7-9).

254. In addition, Ricoh PM and TCRU units are systems with operator enabled maintenance because they provide instructions for an operator to easily remove and replace “replacement units by themselves in just 20-30 minutes.” Ex. __ (PDF of <http://www.ricoh.com.au/support/service-maintenance/production>).

255. Furthermore, Ricoh advertises the advantages of such systems equipped with operator enabled maintenance hardware, software, and instructions, as reducing “scheduled servicing downtime from an industry standard of four to eight hours down to just 20-30 minutes.” Ex. 38 (PDF of <http://www.ricoh.com.au/support/service-maintenance/production>).

256. Ricoh also advertises that “[r]ather than waiting for a technician to arrive for a PM [preventative maintenance] service, an operator can now pick the best time to schedule in the short period of downtime themselves. Ricoh PM and TCRU are available for Ricoh’s colour and black and white production printing devices.” Ex. 39 (PDF of <http://www.ricoh.com.au/support/service-maintenance/production>).

257. Additionally, Ricoh PM and TCRU units provide user guides comprising step-by-step instructions for allowing an operator to perform maintenance that includes removal and replacement of used developer solutions.

6.1 REMOVING THE USED DEVELOPER

Overview

You can remove the developer from more than one developer unit at a time.

Important: Dispose of the developer bottle in accordance with the disposal regulations in your area.

What You Need

- Developer bottle provided with the main machine.

<p>⚠ WARNING</p> <ul style="list-style-type: none"> • Before replacing the developer, make sure that the machine's parts are all closed.

Replacement Message

```
Replacement of Developer is now necessary.
Replace Developer.
```

If this message appears, use the following procedure to replace the unit.

Preparation: Print out the counter list.

1. Press the [Counter] key on the control panel (see "CONTROL PANEL") and print out the counter list.

Important: Before this procedure can be carried out, the machine must be switched on.

Procedure

1. Open the left and right front cover, open the toner hopper cover, and then remove the front top cover. (See "REMOVING THE FRONT TOP COVER".)
2. Check that the developer you are preparing is the correct color by looking at the combination of the raised markings (1) on the shutter of the developer bottle. (The combination indicates the developer color, as shown below.)

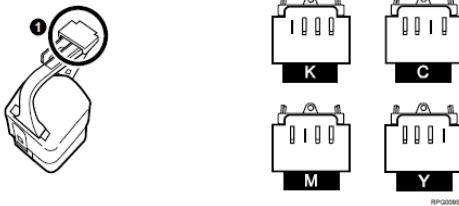

3. Check if the developer bottle is empty.
 4. Align the hole (1) of the bottle with the contact (2) under the outlet for the corresponding developer.
 5. Connect the developer bottle (3).
- Note:** If you want to remove the developer from two or more development units, connect empty bottles to the outlets of those units.

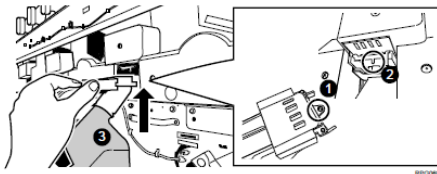

6. Push the developer bottle to in the direction of the arrow (1) until it can go no further and locks into place.

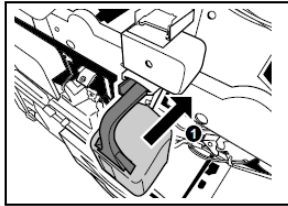

7. Open the TCRU display. (See "OPENING THE TCRU DISPLAY".)
8. Press the [Developer] button.



9. Press the [Reset PM Counter Developer:Exhaust] button.
 10. If a confirmation message appears, press the [Continue] button.
 11. Select the developer you want to replace, and then press the [Continue] button.
 12. If a confirmation message appears, press the [Continue] button.
- Note:** The old developer is discharged.

13. After removing the developer, press the [Confirm] button, and then, while pressing the lock levers on either side of the developer bottle, carefully pull the bottle toward you.

Important: To avoid developer spillage while handling the developer bottle, always keep the developer bottle level.

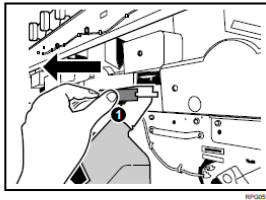

14. Disconnect the developer bottle from the developer outlet contact, and then remove it.

Important: Cover surrounding surfaces with paper. This will prevent spillage from the developer bottle spoiling them.

15. Remove the seal (1) that is stuck to the developer bottle.

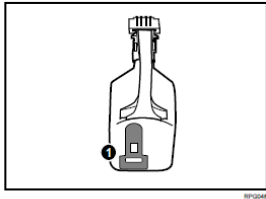

16. Attach the seal (1) to the shutter (1) of the developer bottle, as shown.

Note: To prevent developer leaking during transport, cover the developer bottle's opening.

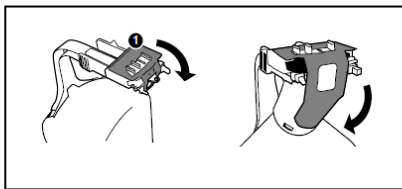

Important: At this point, begin the procedure for adding the new developer. (See "ADDING NEW DEVELOPER")

Ex. 37 (rfg034042 at pp. 33-37).

258. Ricoh PM and TCRU units also enable an operator to perform maintenance on the units. By way of example, Ricoh PM and TCRU units cause display of messages indicative of a need to perform maintenance and the maintenance guides for the units provide operator instructions for the operator to perform the maintenance.

259. As shown below, Ricoh PM and TCRU units cause display of a message indicative of low toner levels and the maintenance guides include toner replacement instructions for an operator to replace used toner cartridges.

Replacing the Toner Cartridge

⚠ WARNING

- *Do not incinerate spilled toner or used toner. Toner dust is flammable and might ignite when exposed to an open flame.*
- *Disposal should take place at an authorized dealer or an appropriate collection site.*
- *If you dispose of the used toner cartridges yourself, dispose of them according to local regulations.*
- *Do not store toner, used toner, or toner containers in a place with an open flame. The toner might ignite and cause burns or a fire.*

⚠ CAUTION

- *Keep toner (used or unused) and the toner cartridge out of reach of children.*
- *If toner or used toner is inhaled, gargle with plenty of water and move into a fresh air environment. Consult a doctor if necessary.*
- *If your skin comes into contact with toner or used toner, wash the affected area thoroughly with soap and water.*
- *If toner or used toner gets into your eyes, flush immediately with large amounts of water. Consult a doctor if necessary.*

⚠ CAUTION

- *If toner or used toner is swallowed, dilute by drinking a large amount of water. Consult a doctor if necessary.*
- *Avoid getting toner on your clothes or skin when removing a paper jam or replacing toner. If your skin comes into contact with toner, wash the affected area thoroughly with soap and water.*
- *If toner gets on your clothing, wash with cold water. Hot water will set the toner into the fabric and may make removing the stain impossible.*

Note

- When handling toner cartridges, never stand them up on either end or position them upside down.
- Store toner cartridges in a cool dark place.
- Actual printable numbers vary depending on image volume and density, number of pages printed at a time, paper type and size, and environmental conditions such as temperature and humidity. Toner quality degrades over time. You may have to replace the toner cartridge prematurely. We recommend you prepare a new toner cartridge beforehand.

The color of the lit LED indicates the toner status for each color. A red light indicates the toner cartridge must be replaced.

Replace the toner cartridge if the following message appears on the display:

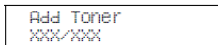

Note

- A combination of one to four colors, yellow, magenta, cyan, black, appears in "XXX".
- If cyan, magenta, or yellow toner runs out, you can print in black and white using black toner. Change the color mode setting to "Black and White" using the printer driver.
- If black toner runs out, you cannot print in black and white or color until the black toner cartridge is replaced.

1 Open the upper left cover of the printer.

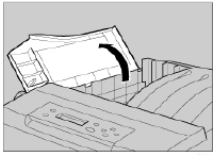

2 Remove the toner cartridge you want to replace.

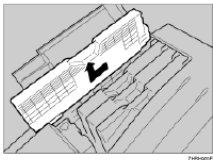

Important

- Do not shake the removed toner cartridge. Remaining toner may leak.

Note

- All four cartridges are removed using the same procedure.
- The illustration uses the yellow cartridge as an example.

3 Take a new toner cartridge out of its package.

4 Shake the toner cartridge from side to side about 10 times.

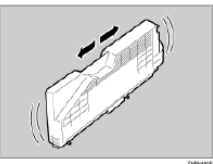

Important

- Do not open the shutter at the bottom of the toner cartridge. Toner may leak.

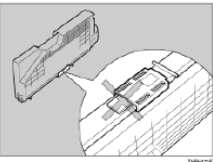

Note

- The illustration uses the black cartridge as an example.

5 Check the toner color and location correspond, and carefully insert the toner cartridge vertically.

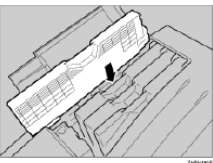

6 Insert the toner cartridge in the direction of the arrow.

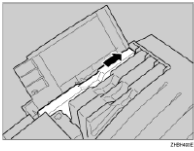

Important

Do not install and remove toner cartridges unless necessary. Excessive handling results in toner leakage.

Note

All four cartridges are installed using the same procedure.

7 Close the printer's upper left cover.

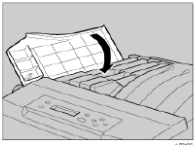

Note

If the toner cartridge is not properly installed, you cannot close the printer's upper left cover.

Ex. 40 (Ricoh Maintenance Guide at pp. 28-31).

260. Claim limitation 1[a] is satisfied for at least the following reasons. As shown below, Ricoh PM and TCRU includes a computational element, such as a system controller that controls the operation of the units. The system controller is a computational element that is connected to the control panel and controls the operation of the printer.

Preparation

Before performing any procedure shown in this manual, always do the following:

1. Shut down the printer controller.
Depending on the type of controller, the shutdown procedure may be slightly different. For details, refer to the shutdown procedure for your machine.
2. Press the operation switch to turn the machine off.
3. After turning off the operation switch, turn off the main power switch.
4. Wait a few seconds, and then disconnect the ground leakage circuit breaker from the machine and fixing heater.

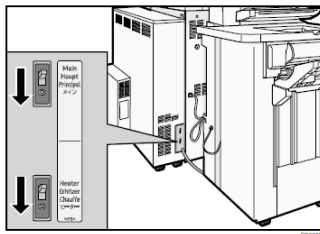

5. The fusing unit becomes extremely hot during normal operation. After turning the machine off and disconnecting the power cable and ground leakage circuit breaker, do not use the machine for at least 30 minutes. This time will allow the fusing unit to cool down.

The operation switch is on the control panel. (See "CONTROL PANEL".)

Ex. 39 (rfg03042.pdf at p. 10).

261. Ricoh PM and TCRU units also include a TCRU SD card which is a computational element that enables a user to change a machine’s service program (SP) adjustment item values.

1.2 ADJUSTMENT: USING THE TCRU SD CARD

The TCRU card enables you to change to the machine's SP adjustment item values when troubleshooting. To change these values, display the [Adjustment] menu using the following procedure.

Ex. 39 (rfg03042.pdf at p. 52).

262. Ricoh PM and TCRU units also include a system auto-reset timer and a computation element connected to the system auto-reset timer to set or reset the system auto-reset timer as shown below.

2.2 Specifying System Auto-Reset Timer

To prevent the machine switching screens while you are replacing parts, set [System Auto Reset Timer] to "Off". Once work is finished, return the setting to "On", if necessary.

NOTE: For details about changing this setting, see General Settings Guide, which is supplied with this machine.

Ex. 37 (rfg.pdf at p. 15).

263. Furthermore, Ricoh PM and TCRU units include a T sensor that is used for sensing toner type. A computational element in the units would send and receive data from the T sensor and automatically perform initialization of the T sensor every time the computation element received data indicative of replacement of the developer.

3-801	Initialize T Sensor	The machine automatically performs the initialization process every time the developer is replaced.
-------	---------------------	-----------------------------------------------------------------------------------------------------

Ex. 39 (rfg034042.pdf at p. 89).

264. Claim limitation 1[b] is satisfied for at least the following reasons. As shown below, Ricoh PM and TCRU include several ORC components, including a charge corona unit, drum unit, drum cleaning unit, developers, paper transfer rolling unit, and image transfer belt

cleaning unit. Ricoh PM and TCRU units provide step-by-step instructions for removing and reinstalling each of the above noted ORC components.

Table of Contents

CONVENTIONS USED IN THIS MANUAL	2
GENERAL SAFETY INSTRUCTIONS	2
1. BEFORE YOU BEGIN	6
2. COMMON PROCEDURES	10
2.1 SWITCH THE MACHINE OFF BEFORE BEGINNING ANY PROCEDURE	10
2.2 OPENING THE TCRU DISPLAY	12
2.3 REMOVING THE FRONT TOP COVER	15
2.4 REATTACHING THE FRONT TOP COVER	16
3. CHARGE CORONA UNIT	17
3.1 REMOVING THE CHARGE CORONA UNIT	17
3.2 REINSTALLING THE CHARGE CORONA UNIT	20
4. DRUM CLEANING UNIT	22
4.1 REMOVING THE DRUM CLEANING UNIT	22
4.2 REINSTALLING THE DRUM CLEANING UNIT	25
5. DRUM UNIT	28
5.1 REMOVING THE DRUM UNIT	28
5.2 REINSTALLING THE DRUM UNIT	30
6. DEVELOPER	33
6.1 REMOVING THE USED DEVELOPER	33
6.2 ADDING NEW DEVELOPER	38
7. IMAGE TRANSFER BELT CLEANING UNIT	41
7.1 REMOVING THE IMAGE TRANSFER BELT CLEANING UNIT	41
7.2 INSTALLING THE IMAGE TRANSFER BELT CLEANING UNIT	44
8. PAPER TRANSFER ROLLER UNIT	46
8.1 REMOVING THE PAPER TRANSFER ROLLER UNIT	46
8.2 INSTALLING THE PAPER TRANSFER ROLLER UNIT	48

Ex. 39 (rfg034042.pdf at pp. 5, 17-20, 22-25, 28-30, 33-38, 41-44, and 46-48).

265. Ricoh PM and TCRU units contain several ORC devices, such as toner cartridges, waste toner bottles, photoconductor unit, fusing unit, and intermediate transfer unit, as shown below.

Replacing Consumables and Maintenance Kit

Replacing the Toner Cartridge	28
Replacing the Waste Toner Bottle	32
Replacing the Photo Conductor Unit	35
Replacing the Fusing Unit	44
When "Replace Fusing Unit" Appears on the Display	49
When "Replace Fusing Unit soon" Appears on the Display	49
Replacing the Intermediate Transfer Unit	51

Ex. 40 (Ricoh Maintenance Guide, Table of Contents, at p. 1).

266. Additionally, Ricoh PM and TCRU include ORC devices, each of which have an expected life span. For example, each toner cartridge of the units is assigned an LED indicator that provides an indication of an expected life span of the toner cartridge. As shown below, “[t]he color of the lit LED indicates the toner status for each color. A red light indicates the toner cartridge must be replaced.”

The color of the lit LED indicates the toner status for each color. A red light indicates the toner cartridge must be replaced.

Ex. 40 (Ricoh Maintenance Guide, at p. 28).

267. Furthermore, Ricoh PM and TCRU comprise control panels with display units that provide an indication of an expected life span of the ORC devices, such as the fusing unit. As shown below, the display provides an indication when: a) the fusing unit requires immediate replacement and b) the fusing unit requires replacement soon.

When "Replace Fusing Unit" Appears on the Display

I If the following message appears on the control panel, hold down the [Escape] key for at least five seconds. The message disappears and a maintenance reset is automatically performed.

REPLACE
Fusing Unit

When "Replace Fusing Unit soon" Appears on the Display

I Press the [Menu] key.

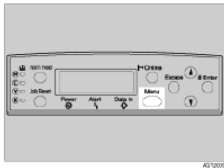

The [Menu] screen appears.

Ex. 40 (Ricoh Maintenance Guide at p. 49).

268. Claim limitation 1[c] is satisfied for at least the following reasons. As shown below, Ricoh PM and TCRU includes a use mechanism, such as a touch-sensitive display, coupled to a computational element, such as a controller and a T sensor (toner density sensor), to initialize an ORC device, such as a toner, and perform adjustments on the ORC device. For example, a T sensor associated with a particular toner may be initialized by a color selection via the touch-sensitive display device.

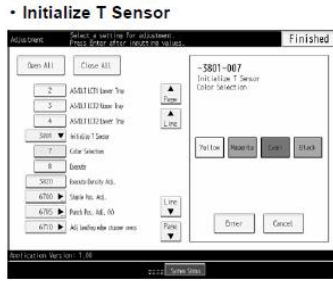

1. Press the color to initialize the sensor, and then press the [#] key.
2. If you press [Execute], the machine carries out initialization every time the developer is replaced.

SP	Item	No.	Setting	Selection	Default Value
3-801	Initialize T Sensor	007	Color Selection	Yellow, Magenta, Cyan, Black	Yellow, Magenta, Cyan, Black
		008	Execute	Execute	-

Ex. 39 (rfg034042.pdf at p. 105).

269. Ricoh PM and TCRU units also include a use mechanism for tracking usage of a developer. The T sensor of Ricoh PM and TCRU units tracks usage of a toner as shown below. The use mechanism would be coupled to the operation of the computational element, such as the controller, and the ORC device, such as the developer, for tracking the usage of the developer. Ricoh PM and TCRU units automatically perform initialization of the T sensor every time the developer is replaced.

3-801	Initialize T Sensor	The machine automatically performs the initialization process every time the developer is replaced.
-------	---------------------	-----------------------------------------------------------------------------------------------------

Ex. 39 (rfg034042.pdf at p. 89).

270. As shown below, Ricoh PM and TCRU units track usage of the developer using at least one predetermined parameter such as color density. The T sensor enables color density adjustments for the developer.

• Execute Density Adj.

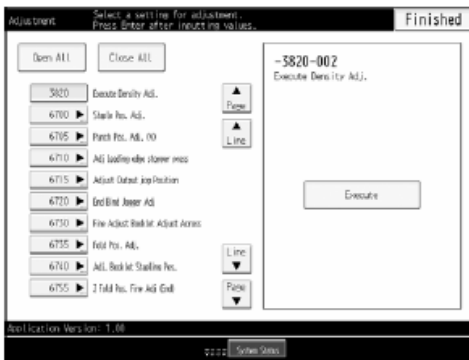

SP	Item	No.	Setting	Selection	Default Value
3-820	Execute Density Adj.	002	-	Execute	-

Ex. 39 (rfg034042.pdf at p. 105).

271. Claim limitation 1[d] is satisfied for at least the following reasons. Ricoh PM and TCRU provide an indication of an expected life span of the installed ORC device, such as the toner and developer, based on a comparison of a current state of the ORC device with the expected life span of the ORC device. For example, each toner cartridge of Ricoh PM and TCRU units is assigned an LED indicator that provides an indication of an expected life span of the toner cartridge. As shown below, “[t]he color of the lit LED indicates the toner status for each color. A red light indicates the toner cartridge must be replaced.” The LED indicator is triggered based on the comparison mechanism that compares use of the toner to the expected life span of the toner.

The color of the lit LED indicates the toner status for each color. A red light indicates the toner cartridge must be replaced.

Ex. 40 (Ricoh Maintenance Guide, at p. 28).

272. Ricoh PM and TCRU units also display service code (SC) lists on the control panel when an ORC device is nearing an end of its expected life span. The display of the SC

codes rely on a comparison mechanism that compares use of the corresponding ORC device to the expected life span of the ORC device.

SC Code List

This table contains a list of selected SC codes. If the SC code that is displayed on the control panel is listed in this table, carry out the recommended procedure. If the SC Code is not listed in this table, contact your service representative.

★ Important

- If the error persists after replacing the unit, contact your service representative.

Code	Error	Procedure
332-01	Toner supply motor error (K): Bottle	Take out and reinsert the toner (black) or replace it.
332-02	Toner supply motor error (C): Bottle	Take out and reinsert the toner (cyan) or replace it.
332-03	Toner supply motor error (M): Bottle	Take out and reinsert the toner (magenta) or replace it.
332-04	Toner supply motor error (Y): Bottle	Take out and reinsert the toner (yellow) or replace it.
410-01	Remaining potential: Vr detection error (K)	Replace the photoconductor unit (black).
410-02	Remaining potential: Vr detection error (C)	Replace the photoconductor unit (cyan).
410-03	Remaining potential: Vr detection error (M)	Replace the photoconductor unit (magenta).
410-04	Remaining potential: Vr detection error (Y)	Replace the photoconductor unit (yellow).
411-01	Charge potential: Vd adjustment error (K)	Replace the charge roller unit (black).
411-02	Charge potential: Vd adjustment error (C)	Replace the charge roller unit (cyan).
411-03	Charge potential: Vd adjustment error (M)	Replace the charge roller unit (magenta).
411-04	Charge potential: Vd adjustment error (Y)	Replace the charge roller unit (yellow).
412-01	Exposure potential: Vpl adjustment error (K)	Replace the photoconductor unit (black) and the charge roller unit (black).
412-02	Exposure potential: Vpl adjustment error (C)	Replace the photoconductor unit (cyan) and the charge roller unit (cyan).

Ex. 41 (Troubleshooting.pdf at p. 14).

273. Ricoh printers further display a notification when: (a) the transfer belt requires immediate replacement and (b) the transfer belt requires replacement soon. The display of the notification in both cases rely on the comparison mechanism that compares a current use of the transfer belt to the expected life expectancy of the transfer belt, thereby notifying an operator of

a need to replace the transfer belt in a timely manner.

Replacing the Intermediate Transfer Unit

⚠ CAUTION

- The inside of this machine gets very hot. Do not touch parts labelled "⚠" (hot surface). Touching "⚠" labelled parts could result in burns.

Replace the transfer belt when the following message appears on the display:

Replace Transfer
Belt soon

or

Replace
Transfer Belt

Check the contents of the box for the following items:

- ❖ Transfer Belt

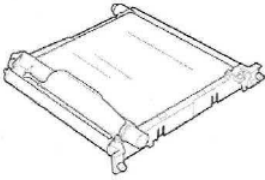

★ Important

- Be sure to make the maintenance setting using the control panel after replacing the transfer belt. The procedure is complete only when the maintenance setting is made.

1 Turn off the power, and then unplug the power cable.

Ex. 40 (Ricoh Maintenance Guide at p. 51).

274. Claim limitation 1[e] is satisfied for at least the following reasons. As shown below, Ricoh PM and TCRU include an operator alert mechanism for performing maintenance that is responsive to the comparison mechanism. When the comparison satisfies the predetermined parameter, such as life of toner is below a certain value, Ricoh PM and TCRU units will provide an operator alert. The operator alert will include an expected life span for an ORC device with the shortest expected life span so that the ORC device that needs replacement soonest is brought to the attention of the operator.

275. Ricoh PM and TCRU also include operator alert mechanisms, such as display of service codes on the control panel, that are responsive to the comparison mechanism. The troubleshooting service codes shown below provide an operator alert when maintenance

operations need to be performed. The operator alerts are based on expected life spans of the ORC devices. As shown below, display of different service codes are indicative of a need to replace different ORC devices, such as the charge roller unit and the photoconductor unit for a corresponding toner color. Each service code provides information on the comparison satisfying at least one predetermined parameter, such as a charge potential and exposure potential, corresponding to a respective ORC device. The ORC device with the shortest expected life span will be included in the operator alert by display of the respective service code.

2. Troubleshooting Service Call Problems (SC Codes)

What Are SC Codes?

If an error occurs during operation, the machine displays an SC code ("SCnnn", where "nnn" is a three-digit number). The machine stops and cannot be used when an SC code is displayed.

If an SC code appears:

1. Write down the SC number.
2. Turn off the main power switch.
3. Wait a few moments, then turn the machine on again.
In most cases, cycling the machine off and on will restore it to full operation.
4. If the SC code reappears, check it against the SC code table. For details, see page 14 "SC Code List".
Check for the SC code in the table.
If the SC code is listed in the table, carry out the recommended procedure.
If the SC code is not listed in the table, contact your service representative.

Code	Error	Procedure
410-01	Remaining potential: Vr detection error (K)	Replace the photoconductor unit (black).
410-02	Remaining potential: Vr detection error (C)	Replace the photoconductor unit (cyan).
410-03	Remaining potential: Vr detection error (M)	Replace the photoconductor unit (magenta).
410-04	Remaining potential: Vr detection error (Y)	Replace the photoconductor unit (yellow).
411-01	Charge potential: Vd adjustment error (K)	Replace the charge roller unit (black).
411-02	Charge potential: Vd adjustment error (C)	Replace the charge roller unit (cyan).
411-03	Charge potential: Vd adjustment error (M)	Replace the charge roller unit (magenta).
411-04	Charge potential: Vd adjustment error (Y)	Replace the charge roller unit (yellow).
412-01	Exposure potential: Vpl adjustment error (K)	Replace the photoconductor unit (black) and the charge roller unit (black).
412-02	Exposure potential: Vpl adjustment error (C)	Replace the photoconductor unit (cyan) and the charge roller unit (cyan).

Code	Error	Procedure
412-03	Exposure potential: Vpl adjustment error (M)	Replace the photoconductor unit (magenta) and the charge roller unit (magenta).
412-04	Exposure potential: Vpl adjustment error (Y)	Replace the photoconductor unit (yellow) and the charge roller unit (yellow).

Ex. 41 (Troubleshooting.pdf at pp. 13-15); Ex. 42 (Ricoh Maintenance Guide at p. 51 and element 1e noted above).

276. As shown below, Ricoh PM and TCRU units include LED indicators that provide operator alerts responsive to the comparison mechanism satisfying a predetermined parameter, such as toner usage, that is representative of at least one of the expected life spans for a single ORC device, such as the toner, that has the shortest expected life span.

The color of the lit LED indicates the toner status for each color. A red light indicates the toner cartridge must be replaced.

Ex. 40 (Ricoh Maintenance Guide, at p. 28)

277. Ricoh also infringes under the doctrine of equivalents because it meets at least, and by way of example, the following claim limitation(s) of representative Claim 1 by performing substantially the same function as this limitation, performing this function in substantially the same way as this limitation, and achieving substantially the same results as claim limitation 1[e]. For example, and without limitation, Ricoh PM and TCRU perform substantially the same function in substantially the same way and achieve substantially the same result at least because they provide an operator alert mechanism (e.g., LED indicators, service codes, transfer belt replacement display notifications) responsive to the comparison mechanism when the result of the comparison satisfies a predetermined parameter (e.g., toner usage, charge potential, exposure potential, belt usage) representing at least one of the expected life spans of the ORC devices, and wherein the expected life span for one of the ORC devices is the shortest expected life span (e.g., the ORC device requires immediate replacement).

278. As a result of Defendant's unlawful activities, MASA has suffered and will continue to suffer irreparable harm for which there is no adequate remedy at law. Accordingly, MASA is entitled to preliminary and/or permanent injunctive relief.

279. Defendant's infringement of the '285 Patent has injured and continues to injure MASA in an amount to be proven at trial.

COUNT VIII

(Direct Infringement of the '998 Patent pursuant to 35 U.S.C. § 271(a))

280. MASA repeats, realleges, and incorporates by reference, as if fully set forth herein, the allegations of the preceding paragraphs, as set forth above.

281. Defendant has infringed and continues to infringe one or more claims of the '998 Patent, including at least claim 1, in violation of 35 U.S.C. § 271(a).

282. Defendant's infringement is based upon literal infringement or infringement under the doctrine of equivalents, or both.

283. Defendant's acts of making, using, importing, selling, and/or offering for sale infringing products and services have been without the permission, consent, authorization, or license of MASA.

284. Defendant's infringement includes the manufacture, use, sale, importation and/or offer for sale of Defendant's products and services, such as Ricoh Aficio MP C2030, C2050, C2530, C2550.

285. Claim 1 of the '998 Patent is recited below:

An image forming apparatus comprising:

1[a] a primary charger for providing a primary charging voltage on an image support

1[b] an image support for supporting an electrostatic latent image on the surface thereof;

1[c] a developing unit having a developing agent support, the developing agent support retaining a developing agent, including toner and carriers, contained in the developing unit, and the developing unit converting the latent image on the image support into a toner image by causing the toner to adhere to the surface of the image support;

1[d] a developing bias supplying unit for supplying a developing bias voltage to the developing agent support of the developing unit; and

1[e] a controller for setting the developing bias voltage and primary charging voltage at predetermined values undesirable for normal image forming operation in order to provide diagnostic information on the image forming apparatus.

286. As one example of how the '998 Accused Products infringe at least claim 1, Ricoh Aficio MP C2030 meets the limitations of claim 1 of the '998 Patent for at least the reasons described below.

287. An image of Ricoh Aficio MP C2030 is provided below:



Ex. 42 (C2030_C2050_Service_Manual.pdf at p. 1).

288. As a general matter and as explained below, the limitations of claim 1 are satisfied because Ricoh Aficio MP C2030 are image forming printers that print single-sided or double-sided images in full color/black and white.



Ex. 42 (C2030_C2050_Service_Manual.pdf at p. 1).

289. As shown below, Ricoh Aficio systems automatically begin an initialization process for image developer once powered ON. An automatic color calibration process is followed for printing images at varying resolutions.

Initialize the Developer

1. Make sure that the platen or ARDF is closed and the main power is turned off.
2. Plug in the machine.
3. Turn the main power switch on. The machine automatically starts the initialization procedure. The Start button LED (Ⓢ) turns green when this procedure has finished.
4. Make copies of image samples (text, photo, and text/photo modes).
5. Do the Automatic Color Calibration process (ACC) for each mode (Copy mode, Printer 600 x 600 dpi, Printer 1800 x 600 dpi, and Printer 1200 x 1200 dpi) as follows ((Printer 1200 x 1200 dpi is for D038/D041 only):

Ex. 42 (C2030_C2050_Service_Manual.pdf at p. 64).

Original Size:	Book (Face down)
	Maximum Length: 432 mm [17 ins]
	Maximum Width: 297 mm [11.7 ins]
	ARDF (Face up)
	(Single-sided document)
	Length: 128 - 1200 mm [5.0 - 47.2 ins]
	Width: 105 - 297 mm [4.1 - 11.7 inch]
	(Double-sided document)
Length: 128 - 432 mm [5.0 - 17 inch]	
Width: 105 - 297 mm [4.1 - 11.7 inch]	

Ex. 42 (C2030_C2050_Service_Manual.pdf at p. 1165).

290. Claim limitation 1[a] is satisfied for at least the following reasons. As shown below, Ricoh Aficio MP C2030 contains a primary charger for providing a charging voltage to an imaging support, such as a photoconductor drum. The primary charger is, for example, a high-voltage power supply (HVPS) unit, whereby the HVPS unit shown below is controlled by the TTS board and the controller box (CB) circuit board to generate a primary charging voltage.

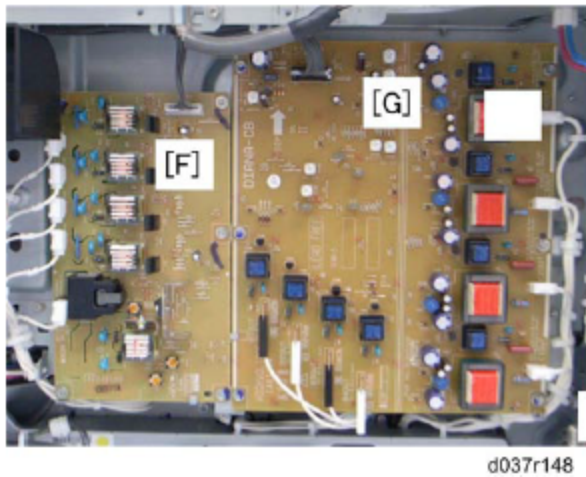

[F]	HVPS: TTS Board
[G]	HVPS: CB Board

Ex. 42 (C2030_C2050_Service_Manual.pdf at p. 297).

291. As shown below, the service code table for Ricoh Aficio correlates drum/development bias output errors with the HVPS unit such that, the HVPS unit provides charging voltages to the drum, that functions as an image support, during the printing process.

No.	Type	Details (Symptom, Possible Cause, Troubleshooting Procedures)
491	D	High voltage power: Drum/ development bias output error
		An error signal is detected for 0.2 seconds when charging the drum or development.
		<ul style="list-style-type: none"> ▪ High voltage leak ▪ Broken harness ▪ Defective drum unit or development unit ▪ Defective HVPS-CB board

Ex. 42 (C2030_C2050_Service_Manual.pdf at p. 442).

292. In addition, the service modes for Ricoh Aficio include a description of the charge roller bias. The DC component of the charge roller bias is adjusted for different print modes and the charge roller bias provides the bias voltage for charging the photoconductor drum surface that serves as an imaging support.

SP2-XXX (Drum)

2005	<p>[Charge DC V:Fixed] (Paper Type, Process Speed, Color) Paper Type -> Plain, Thick 1, Thick 2</p>
	<p>Adjusts the DC component of the charge roller bias in the various print modes. Charge bias (DC component) is automatically adjusted during process control; therefore, adjusting these settings does not effect while process control mode (SP3-041-1 Default: ON) is activated. When deactivating process control mode with SP3-041-1, the values in these SP modes are used for printing.</p>

Ex. 42 (C2030_C2050_Service_Manual.pdf at p. 558).

293. In addition, shown below is the drum unit and the development unit, whereby the charge roller is positioned in close proximity to the drum surface to provide the bias voltage.

Image Creation

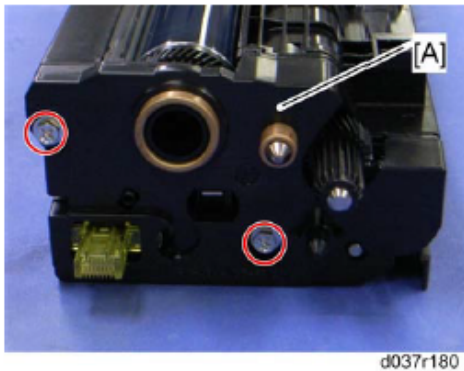

6. Rear cover [A] (📎 x 2)

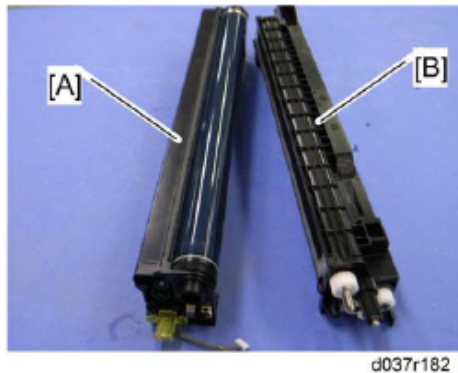
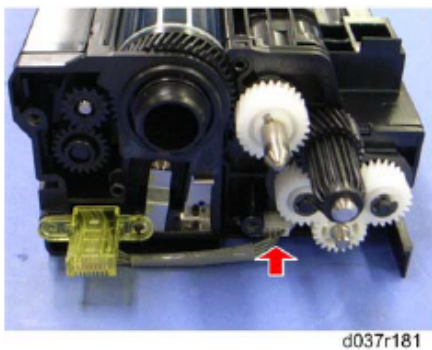

7. Drum unit [A] and development unit [B] (📎 x 1)

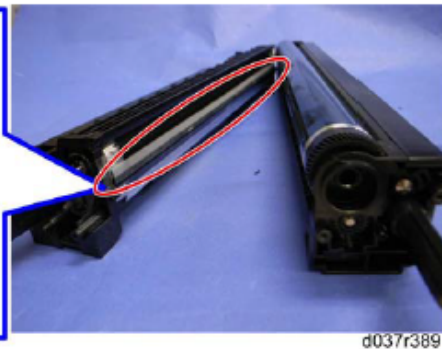
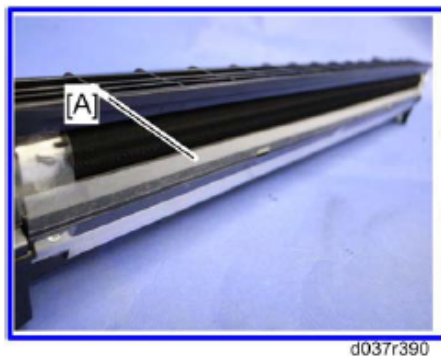

Ex. 42 (C2030_C2050_Service_Manual.pdf at p. 220); Ex. 43 (PDF of Ex. (PDF of <https://www.youtube.com/watch?v=tlfLqv5f-Uo>); Ex. 44 (PDF of <https://www.youtube.com/watch?v=QrogS7E4WQE>).

294. Claim limitation 1[b] is satisfied for at least the following reasons. Ricoh Aficio MP C2030 includes conductive drum surfaces that serve as an image support for supporting an electrostatic latent image on the surface thereof. Ricoh Aficio C2030 also include development units that are used to form the electrostatic latent images on the conductive drum surfaces.

295. As shown below, Ricoh Aficio MP C2030 includes the drum unit 22 that serves as the image support for supporting the electrostatic latent image on its surface and the development unit 23 that enables the formation of the electrostatic latent image on the surface of the drum unit 22.

2.1.1 MECHANICAL COMPONENT LAYOUT

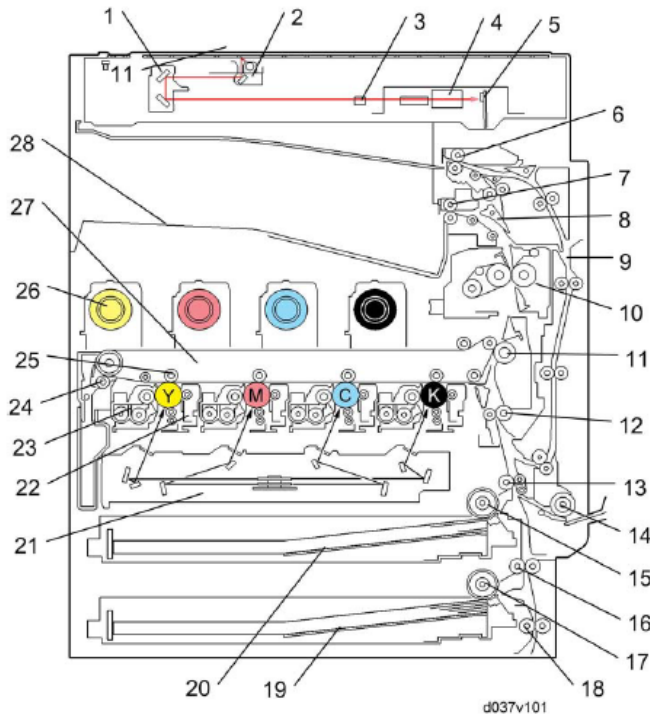

7. Paper exit roller	22. Drum unit
8. Junction gate	23. Development unit
9. Duplex unit	24. ITB cleaning unit
10. Fusing unit	25. ITB roller
11. PTR (Paper transfer roller) unit	26. Toner bottle
12. Registration roller	27. ITB (Image Transfer Belt) unit
13. Vertical transport roller 1	28. Inner Tray
14. By-pass feed roller	
15. Feed roller: T1	

Ex. 42 (C2030_C2050_Service_Manual.pdf at pp. 409-410).

296. As shown below, Ricoh Aficio include a laser unit which forms an electrostatic image on the surface of the drum based on image data inputted.

Preparing a new laser unit

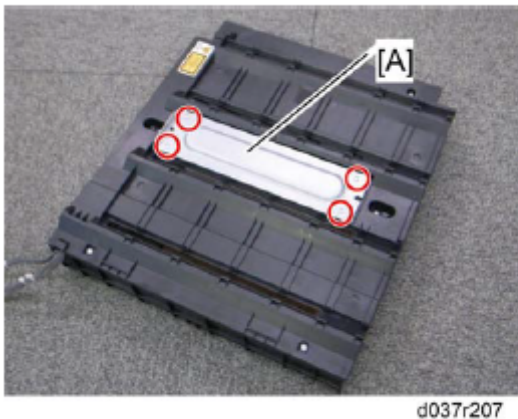

d037r207

1. Polygon mirror motor cover [A] of the laser unit (4 x)

Ex. 42 (C2030_C2050_Service_Manual.pdf at p. 212).

297. As shown below, the laser unit includes a laser, mirrors, and motors, whose settings are adjusted for each of the toner colors. Using these components, the charged drum surfaces of Ricoh Aficio C2030 are scanned by laser beams to form invisible electrostatic latent images during an exposure phase of the print process.

adjustment motors in the laser unit.

1. Plug in and turn on the main power switch of the copier.
2. Enter the SP mode.
3. Execute SP2-220-001 to clear the Mirror-No.2 positioning motor setting for Cyan.
4. Execute SP2-220-002 to clear the Mirror-No.2 positioning motor setting for Magenta.
5. Execute SP2-220-003 to clear the Mirror-No.2 positioning motor setting for Yellow.
6. Exit the SP mode.
7. Turn off the main power switch and disconnect the power cord of the copier.

Ex. 42 (C2030_C2050_Service_Manual.pdf at p. 213).

298. Claim limitation 1[c] is satisfied for at least the following reasons. Ricoh Aficio MP C2030 includes a developing unit that develops the toners and forms the toner images on charged drum surfaces by causing the toners to adhere to the respective drum surfaces. The developing unit of Ricoh Aficio MP C2030 comprises a developing agent support retaining a developing agent, including several toners and carriers.

299. As shown below, Ricoh Aficio MP C2030 include a development unit (e.g., 23 in the image below) that comprises a developing agent support retaining a developing agent, including toners (e.g., 26 in the image below), such as Yellow, Magenta, Cyan and Black, and toner carriers [B].

Developer and Toner Bottles

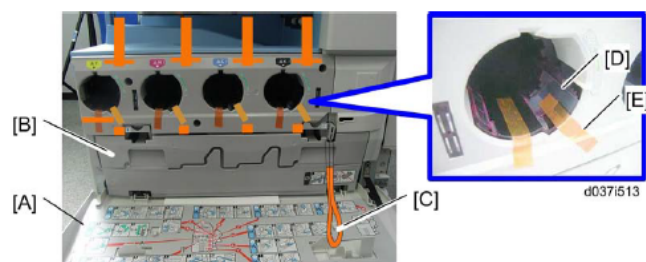

1. Open the front door [A] and remove the PCDU toner collection bottle [B].
2. Remove all tapes except the tape [C] from the four development units and from the toner hopper units.

2.1.1 MECHANICAL COMPONENT LAYOUT

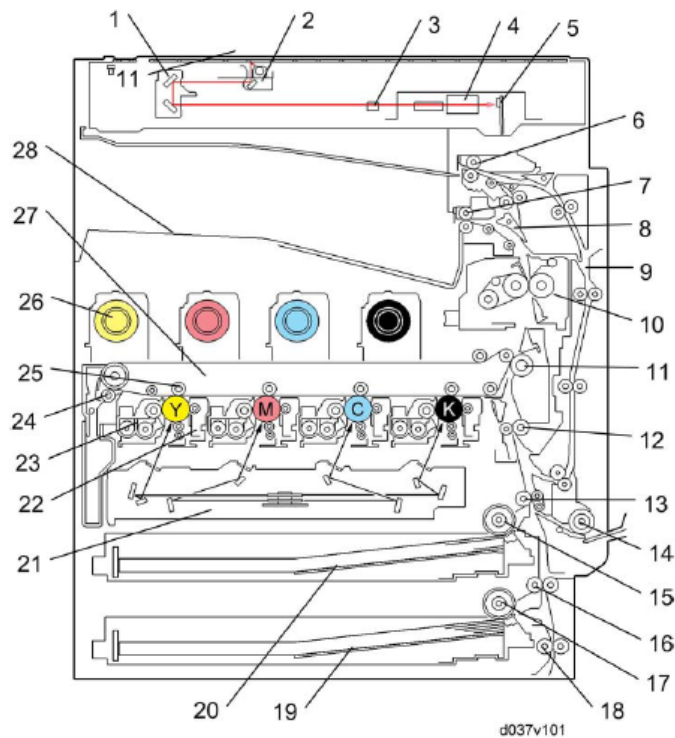

7. Paper exit roller	22. Drum unit
8. Junction gate	23. Development unit
9. Duplex unit	24. ITB cleaning unit
10. Fusing unit	25. ITB roller
11. PTR (Paper transfer roller) unit	26. Toner bottle
12. Registration roller	27. ITB (Image Transfer Belt) unit
13. Vertical transport roller 1	28. Inner Tray
14. By-pass feed roller	
15. Feed roller: T1	

Ex. 42 (C2030_C2050_Service_Manual.pdf at pp. 61 and 409-410).

300. Shown below is the photoconductor drum and development unit of Ricoh Aficio MP C2030.

4.7 IMAGE CREATION

4.7.1 PCDU (PHOTO CONDUCTOR AND DEVELOPMENT UNIT)

↓ Note

- Do not touch the OPC drum. Do not let metal objects touch the development sleeve.
1. Open the front door.
 2. PCDU toner collection bottle (← Section: PCDU Toner Collection Bottle)

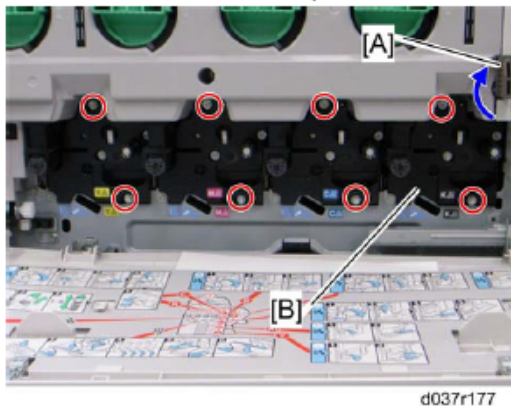

3. Turn the ITB lock lever [A] to the 'up' position.
 4. PCDU [B] (⚙ x 2 each)
- Ex. 42 (C2030_C2050_Service_Manual.pdf at p. 218).

301. Ricoh Aficio MP C2030 also includes a developing agent support, such as a toner hopper unit, respectively corresponding to each toner color, such as Black (K), Cyan (C) and Magenta (M) as shown below. As shown in the image of the toner hopper unit Y, reproduced below, the toner hopper unit is contained in the development unit of Ricoh Aficio MP C2030.

Image Creation

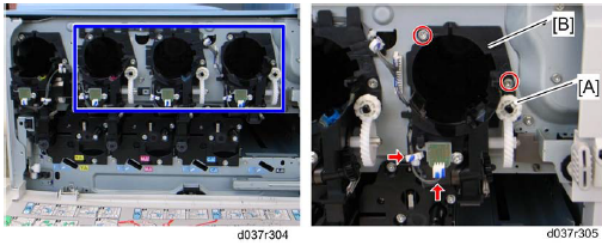

5. Toner supply drive gear [A] (hook x 1)
6. Toner hopper unit: K, C, M [B] (⌀ x 2, ⌀ x 1 for K and M; 2 for C, ⌀ x 1 each)

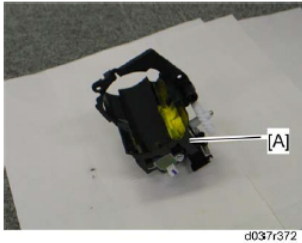

7. Place the toner hopper unit [A] on sheets of paper.

Toner hopper unit: Y

1. Open the front door.
2. PCDU toner collection bottle (Section: PCDU Toner Collection Bottle)
3. Inner cover (Section: Inner Cover)
4. PCDU (Section: PCDU (Photo Conductor and Development Unit))

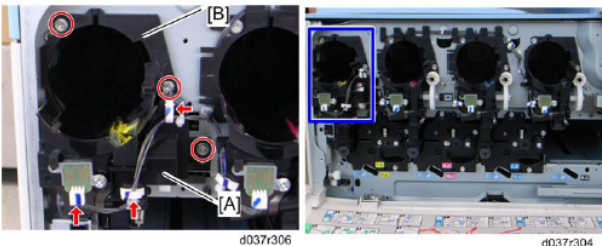

5. Gear cover [A] (⌀ x 2, ⌀ x 2)

Ex. 42 (C2030_C2050_Service_Manual.pdf at p. 222).

302. As shown below, developer is added to each toner hopper unit. The black developer bottle, as reproduced below, is labeled K. The color toner hopper units use a common developer bottle without a label and are thus distinguishable over the black developer bottle. As such, Ricoh Aficio MP C2030 includes developing agent supports, such as toner hopper units, that retain a developing agent, including toners and carriers, in the developing unit.

When installing a new toner hopper unit

Developer must be added to the new toner hopper. Some developer (8 g) is provided with each new toner hopper unit. Pour this into the toner hopper unit before reattaching the inner cover.

⇒ 1. Slowly open the toner hopper shutter [A].

↓ Note

- Do not try to open the toner hopper shutter fully at one try. This shutter comes off easily without the inner cover. If the toner hopper shutter has come off, reattach it.

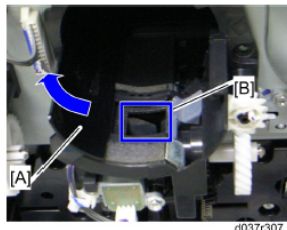

2. Pour the developer (8 g) into the inlet [B] of the toner hopper unit.
3. Close the toner hopper shutter.
4. Reassemble the machine.

The black developer bottle is labeled as shown in the photograph to the right: The color toner hopper units use a common developer bottle without any label. So, it should be easy to distinguish color carrier bottles from the black one.

CAUTION

When cleaning a toner hopper unit, be careful not to vacuum the developer from the bottom of the hopper.



Ex. _ (C2030_C2050_Service_Manual.pdf at p. 223).

303. Using these components, Ricoh Aficio MP C2030 converts electrostatic images on the drum surfaces into toner images by providing a supply of toner to the charged drum surfaces. For example, the toner is positively charged while the electrostatic latent image on the drum surface contains a negative charge. During the print process, the developing unit provides a supply of the positively charged toner which in turn electrostatically binds to the negative electrostatic latent image on the charged drum surface thereby forming a toner image on the drum surface. Therefore, the developing unit converts the latent image on the image support into a toner image by causing the toner to adhere to the surface of the image support

304. Claim limitation 1[d] is satisfied for at least the following reasons. Ricoh Aficio MP C2030 includes a developing bias supplying unit such as the high-voltage power supply (HVPS) unit for supplying a developing bias voltage to a developing agent support of the development unit.

305. As shown below, Ricoh Aficio MP C2030 includes a high-voltage power supply (HVPS) unit, whereby the operation of the HVPS unit is controlled by the TTS board and the controller box circuit board.

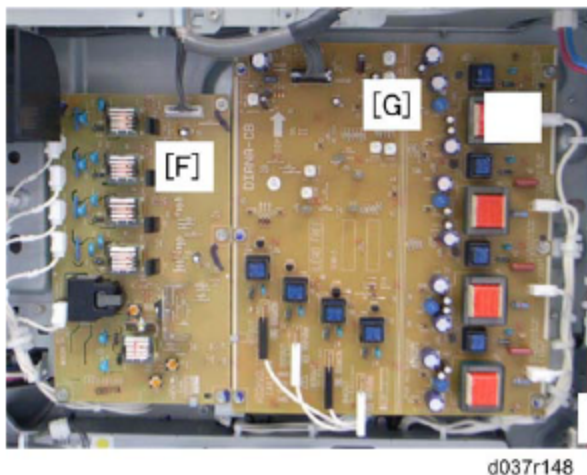

[F]	HVPS: TTS Board
[G]	HVPS: CB Board

Ex. 42 (C2030_C2050_Service_Manual.pdf at p. 297).

306. As shown below, the service code table for Ricoh Aficio MP C2030 correlates drum/development bias output errors with the HVPS unit such that the HVPS unit supplies a developing bias voltage to a developing agent support of the developing unit during the printing process in order to appropriately bias the drum surface.

No.	Type	Details (Symptom, Possible Cause, Troubleshooting Procedures)
491	D	High voltage power: Drum/ development bias output error
		An error signal is detected for 0.2 seconds when charging the drum or development.
		<ul style="list-style-type: none"> ▪ High voltage leak ▪ Broken harness ▪ Defective drum unit or development unit ▪ Defective HVPS-CB board

Ex. 42 (C2030_C2050_Service_Manual.pdf at p. 442).

307. Ricoh Aficio MP C2030 also uses a magnetic roller biased with a negative voltage to attract toner from the toner carriers. The toner is then exposed to a charged drum surface, with an electrostatic image, that is more negatively charged than the magnetic roller, wherein the charged drum surface is biased based on the voltage supplied by the HVPS unit. The toner is then electrostatically attached to the negatively charged drum surface to form the toner image.

308. Claim limitation 1[e] is satisfied for at least the following reasons. Ricoh Aficio MP C2030 includes a controller comprising a controller board that controls the operation of the HVPS unit. The control of the operation of the HVPS unit includes setting the developing bias voltage supplied to the magnet roller and the primary charging voltage supplied to the charge roller at predetermined values undesirable for normal image forming operation in order to provide diagnostic information on Ricoh Aficio printers.

309. As shown below, Ricoh Aficio MP C2030 includes a controller box containing a controller board that controls the HVPS unit. Therefore, setting the developing bias voltage and primary charging voltage is based on the controller board controlling the operation of the HVPS unit.

3. Open the controller box (☛ Section: Controller Box)

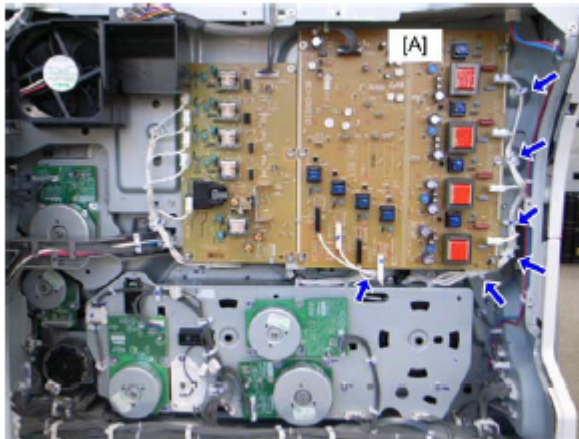

d037r165

4. Remove all connectors and clamps (blue arrows) on the HVPS: CB board [A].

Ex. 42 (C2030_C2050_Service_Manual.pdf at p. 244).

310. In addition, the controller board for controlling the HVPS unit is shown below.

Setting the developing bias voltage and the primary charging voltage is based on the controller board controlling the operation of the HVPS unit.

4.15.10 HVPS: CB BOARD

1. Rear cover (☛ Section: Rear Cover)
2. Open the controller box (☛ Section: Controller Box)

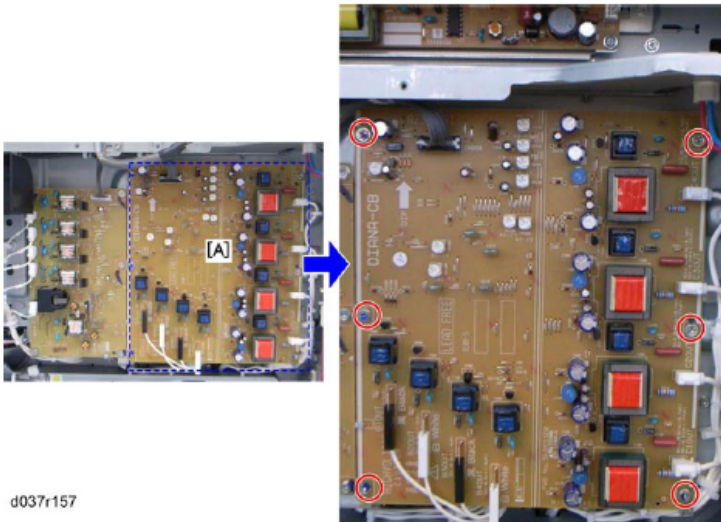

d037r157

3. HVPS: CB board [A] (☛ x 6, All ☛ s)

Ex.42 (C2030_C2050_Service_Manual.pdf at p. 303).

311. As shown below, the controller is used for running diagnostics.

8XX	Controller	800 -	Error after ready condition
		820 -	Diagnostics error

Ex. 42 (C2030_C2050_Service_Manual.pdf at p. 425).

312. Based on the foregoing, Ricoh Aficio MP C2030 uses the controller for setting different biasing voltages and charging voltages for providing diagnostic information pertaining to the printing process. As such, the controller would set the developing bias voltage and the primary charging voltage at predetermined values that are undesirable for normal image forming operation of Ricoh Aficio MP C2030 printers for carrying out diagnostic procedures.

313. Furthermore, the troubleshooting procedures for Ricoh Aficio MP C2030, shown below, correlate the HVPS-CB board with the drum/development bias output errors. Therefore, the HVPS-CB functions as a controller for setting the developing bias voltage and primary charging voltage at different predetermined values for providing diagnostic information on the printers. Moreover, the predetermined values for the developing bias voltage and primary charging voltage for troubleshooting purposes may be different from and undesirable for normal operation of Ricoh Aficio MP C2030 printers.

No.	Type	Details (Symptom, Possible Cause, Troubleshooting Procedures)
491	D	High voltage power: Drum/ development bias output error
		An error signal is detected for 0.2 seconds when charging the drum or development.
		<ul style="list-style-type: none"> ▪ High voltage leak ▪ Broken harness ▪ Defective drum unit or development unit ▪ Defective HVPS-CB board
		<ol style="list-style-type: none"> 1. Check or replace the harness. 2. Replace the drum unit or paper transfer unit. 3. Replace the HVPS-CB board.

Ex. 42 (C2030_C2050_Service_Manual.pdf at p. 442).

314. In addition, the system service mode 2326 of Ricoh Aficio MP C2030 describes different bias adjustments applied to the transfer roller while carrying out diagnostic procedures. The different bias adjustments comprise setting developing bias voltages and charging voltages that are undesirable for normal operation of Ricoh Aficio MP C2030 printers.

System Service Mode

2326	[Transfer Roller CL: Bias] Transfer Roller Cleaning: Bias Adjustment		
001	Positive:before and after JOB	*ENG	[0 to 2100 / 250 / 10 V /step]
	Adjusts the positive voltage of the paper transfer roller for cleaning the paper transfer roller.		
002	Negative:before and after JOB	*ENG	[10 to 400 / 100 / 10 %/step]
	Adjusts the negative current of the paper transfer roller for cleaning the paper transfer roller.		
003	Positive:after JAM	*ENG	[0 to 2100 / 2000 / 10 V/step]
	Adjusts the positive current limit of the paper transfer roller for cleaning the paper transfer roller.		
004	Negative:after JAM	*ENG	[10 to 400 / 100 / 10 %/step]

Ex. 42(C2030_C2050_Service_Manual.pdf at p. 590).

315. Furthermore, the system service mode 3041 of Ricoh Aficio MP C2030 describes use of predetermined values for setting the development bias voltages and the charge voltages depending upon the diagnostic procedure needed, such as SP2-005 and SP2-229 shown below. Based on the foregoing, Ricoh Aficio MP C2030 sets the developing bias voltage and the primary charging voltage to different predetermined values for providing diagnostic information.

System Service Mode

3041	[Process Control Type]		
001	Voltage Control	*ENG	[0 or 1 / 1 / 1/step] Alphanumeric 0: FIXED (Use the fixed values for the charge DC bias and development DC bias set with SP2-005 and SP2-229.) 1: CONTROL
Enables or disables potential control.			

Ex 42 (C2030_C2050_Service_Manual.pdf at p. 650).

316. Ricoh also infringes under the doctrine of equivalents because it meets at least, and by way of example, the following claim limitation (s) of representative Claim 1 by performing substantially the same function as this limitation, performing this function in substantially the same way as this limitation, and achieving substantially the same results as claim limitation 1[e]. For example, and without limitation, Ricoh Aficio MP C2030 performs substantially the same function in substantially the same way and achieves substantially the same result at least because it includes a controller for setting the developing bias voltage (e.g., drum voltage) and the primary charging voltage (e.g., charge roller voltage) at different predetermined values that are undesirable for normal printing and for providing diagnostic information.

317. As a result of Defendant's unlawful activities, MASA has suffered and will continue to suffer irreparable harm for which there is no adequate remedy at law. Accordingly, MASA is entitled to preliminary and/or permanent injunctive relief.

318. Defendant's infringement of the '998 Patent has injured and continues to injure MASA in an amount to be proven at trial.

COUNT IX

(Direct Infringement of the '9005 Patent pursuant to 35 U.S.C. § 271(a))

319. MASA repeats, realleges, and incorporates by reference, as if fully set forth herein, the allegations of the preceding paragraphs, as set forth above.

320. Defendant has infringed and continues to infringe one or more claims of the '9005 Patent, including at least claim 1, in violation of 35 U.S.C. § 271(a).

321. Defendant's infringement is based upon literal infringement or infringement under the doctrine of equivalents, or both.

322. Defendant's acts of making, using, importing, selling, and/or offering for sale infringing products and services have been without the permission, consent, authorization, or license of MASA.

323. Defendant's infringement includes the manufacture, use, sale, importation and/or offer for sale of Defendant's products and services, such as Ricoh TotalFlow.

324. Claim 1 of the '9005 Patent is recited below:

A system for pre-selecting ordered media in a printing system, comprising:

1[a] an input source to store at least one set of the ordered media;

1[b] a user interface having an input device to select the ordered media from a paper catalog, and to pre-select a first part of the ordered media set to be used in a print job and a second unwanted part of the ordered media set to be discarded;

1[c] a first job output;

1[d] a second job output; and

1[e] a central processing unit configured to send the first part of the ordered media set directly to the first job output and the second part of the ordered media set directly to the second job output.

325. As one example of how the '9005 Accused Products infringe at least claim 1, Ricoh TotalFlow meets the limitations of claim 1 of the '9005 Patent for at least the reasons described below.

326. As a general matter and as explained below, the limitations of claim 1 are satisfied because Ricoh TotalFlow provides a system for creating a printed document (printing system) that includes a graphical user interface (“GUI”) that enables a user to select documents before they are used in a print job (pre-selecting ordered media). Also, Ricoh TotalFlow is configured to retrieve documents for use in the print job from memory resident on the computer system (input source).

327. As shown in the figure below, Ricoh TotalFlow provides a system for printing a document when it provides software components that enable a user to select which pages of a document are to be used in a print job (system for pre-selecting ordered media in a printing system).

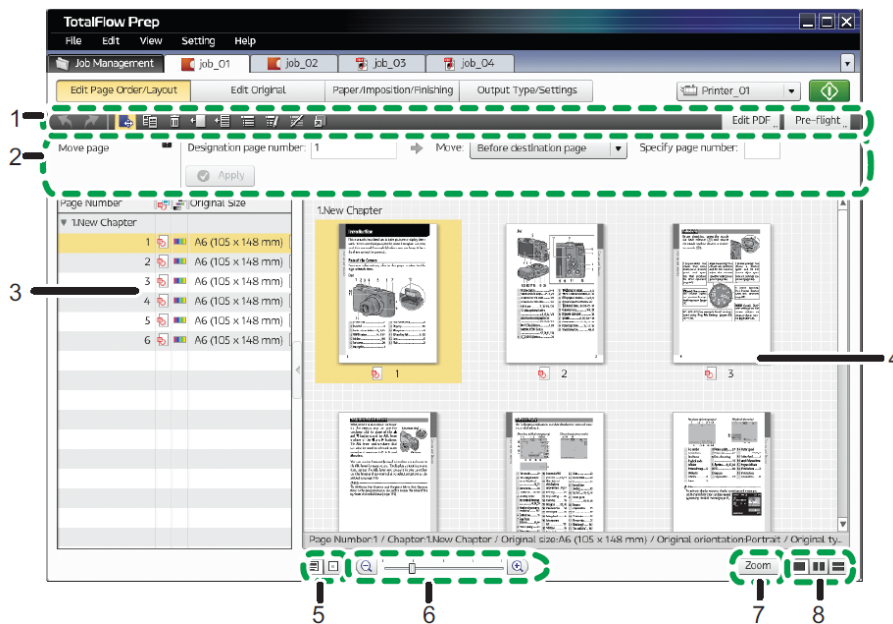

Ex. 45 (TotalFlow User Guide.pdf at page 55).

328. Claim limitation 1[a] is satisfied for at least the following reasons. As shown in the excerpt below, Ricoh TotalFlow uses an input source to store at least one set of the ordered media when it retrieves, from storage, data portions of the ordered media from

computer memory ((e.g., 10 GB of resident computer memory including random-access memory (“RAM”), read-only memory (“ROM”), and the like).

Items	Descriptions			
System Requirements	OS	Edition	32 bit (x86)	64 bit (x64)
	Windows® 7 (SP1)	Professional, Enterprise, Ultimate	X	X
	Windows 8 and 8.1	Professional, Enterprise	X	X
	Windows 10	Professional, Enterprise		X
	Windows Server® 2008 R2	Standard, Enterprise		X
	Windows Server 2012, plus R2	Standard		X
Computer	<ul style="list-style-type: none"> • CPU: 3 GHz or higher recommended (minimum 2 GHz) • Main memory: 8 GB or higher recommended (minimum 4 GB) 			
Hard Disk	<ul style="list-style-type: none"> • 10 GB of available space is recommended for the initial installation 			
Display	<ul style="list-style-type: none"> • 1,440 x 900 pixels or greater recommended (minimum 1,024, x 768 pixels) • 16.7 million colors or more recommended (minimum 64,000 colors) 			
Printer	<ul style="list-style-type: none"> • Printer P53 option may be required 			
Network	<ul style="list-style-type: none"> • Ethernet LAN adapter (at least 100 Mbps, wired LAN recommended) • TCP/IP protocol (IPv4) 			
Web Browser	<ul style="list-style-type: none"> • To use the web browser version of RICOH TotalFlow® Prep, one of the following browsers is required: Internet Explorer® 10 or later, Mozilla Firefox® (current plus two previous versions), Google Chrome™ (current plus two previous versions), Apple® Safari® 7 or 8 			
Flash Player	<ul style="list-style-type: none"> • Adobe® Flash® Player version 11.2 or later required to display web application version of TotalFlow Prep 			
Base Product	<ul style="list-style-type: none"> • RICOH TotalFlow Prep 			

Ex. 45 (TotalFlow_Prep.pdf at page 4).

329. Claim limitation 1[b] is satisfied for at least the following reasons. Ricoh TotalFlow provides a user interface having an input device that selects the ordered media from a paper catalog when it enables the user to use the GUI to select paper with desirable properties, from a paper catalog, for use in a print job. Ricoh TotalFlow also pre-selects a first part of the ordered media set to be used in a print job when it provides a GUI that enables a user to select a subset of pages/tabs of a document to be printed. Furthermore, Ricoh TotalFlow pre-selects a second unwanted part of the ordered media set to be discarded when it determines which portions of the document are unwanted for the print job based on identified user selections.

330. For instance, as shown in the figure below, Ricoh TotalFlow includes a “Paper Catalog” menu option that enables a user to select paper to be used in a print job from different paper types (input on an interface).

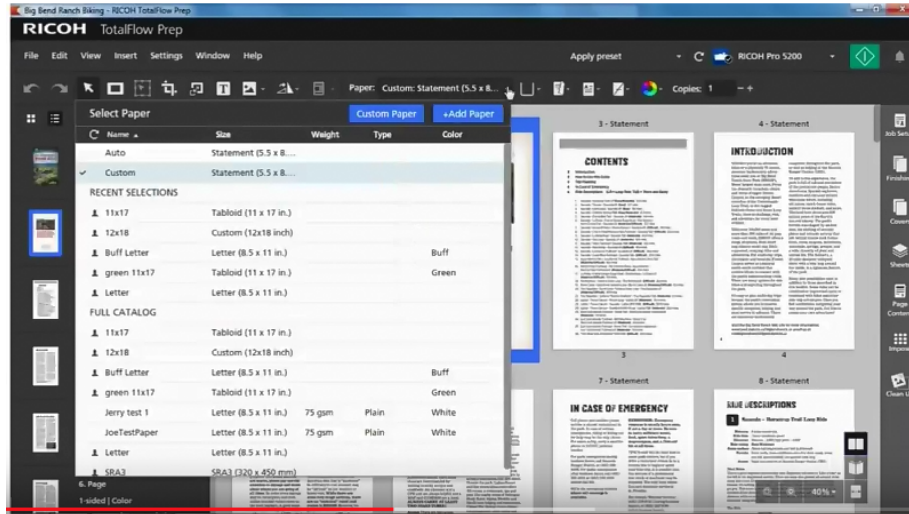

Ex. 46 (PDF of <https://www.youtube.com/watch?v=e9l73WVW61Y&t=29s> ((RICOH TotalFlow Prep PODi Product Briefing (Overview))).

331. As shown in the figure below, a user can select a desirable stock of physical paper from a paper catalog for use in the print job (associating the ordered media with an entry in a paper catalog) and may further select from, among other options, a number of different paper sizes, colors, weights, etc.

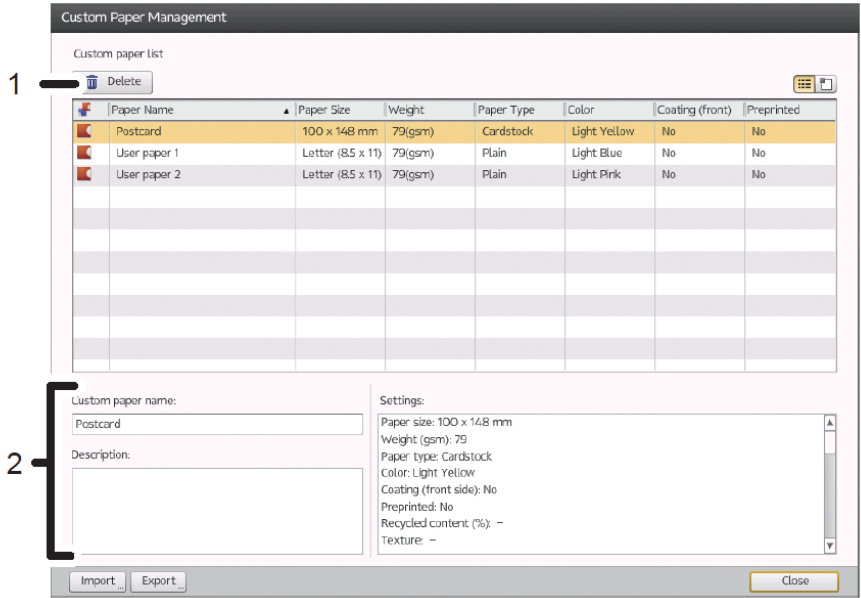

Ex. 45 (TotalFlow User Guide.pdf at page 55).

332. As shown in the figure below, Ricoh TotalFlow allows users to pre-select a first part of a set of the ordered media to be used in a print job in response to another input on the interface when it provides users, on a portion of the GUI, an option to select pages / documents to be included in a print job.

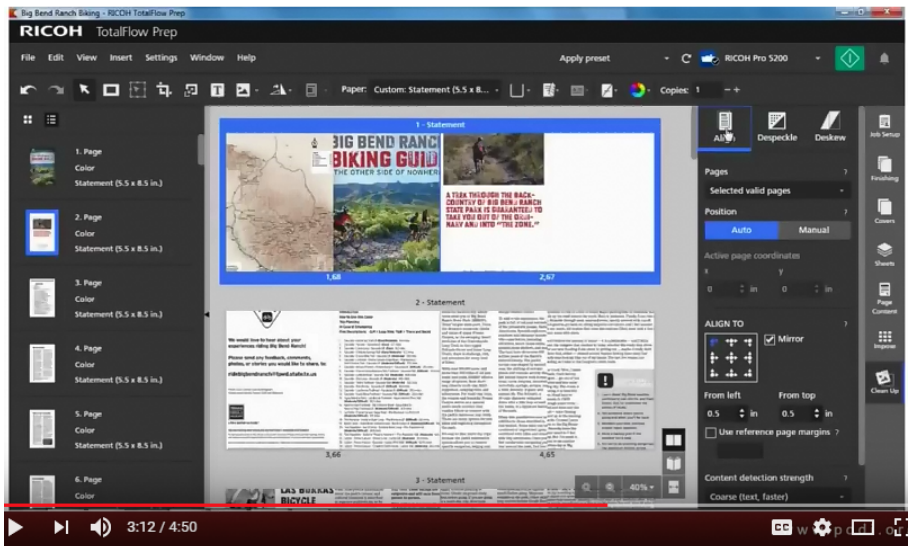

Ex. 46 (PDF of <https://www.youtube.com/watch?v=e9l73WVW61Y&t=29s> ((RICOH TotalFlow Prep PODi Product Briefing (Overview))).

333. As shown in the excerpt below, Ricoh TotalFlow determines a second unwanted part of the ordered media set to be discarded when it identifies selections made by a user that define media exceptions that enact the “automatic ejection of unused tabs.” For instance, unused pages/tabs identified by Ricoh TotalFlow can include pages/tabs that are not within a particular range of pages selected by the user for the print job.

More media, fewer problems

When it comes to printed communications, standing out starts at the substrate. With that in mind, RICOH TotalFlow Prep enables printers to take a flexible approach to media, allowing them to add custom media or select from among printer media catalogs, which can be accessed directly via Ricoh and EFI JDF-enabled controllers. Additionally, users can quickly and easily define media exceptions or specifications, enact automatic ejection of unused tabs when supported, and easily set cover stock on magazines or booklets that have already been imposed. Use your substrates, your way, without having to awkwardly, manually navigate transitions between them within jobs.

Ex. 45 (TotalFlow_Prep.pdf at page 3).

334. Claim limitation 1[c] is satisfied for at least the following reasons. As shown below, Ricoh TotalFlow may specify that media that includes, for example, tabs (ordered media) be outputted to a tray specified by the user via a GUI. For instance, as shown in the excerpt below, Ricoh TotalFlow configures the printing system to send the first part of the ordered media set directly to a first job output when it specifies that media that includes usage of tabs (ordered media) be outputted to a specific tray based on a selection provided by the user via the “Printer” tab.

Input Trays

The Input Trays pod on the Printer tab lets you enable or disable the printer input trays and edit the paper in the input trays.

Interposer Trays

The Interposer Trays pod on the Printer tab lets you enable or disable the printer interposer trays and edit the paper in the interposer trays.

Output Trays

The Output Trays pod on the Printer tab lets you enable or disable the printer output trays.

Ex. 33 (M2737502_en.pdf at page 33).

335. Claim limitation 1[d] is satisfied for at least the following reasons. As shown below, Ricoh TotalFlow specifies that media that includes, for example, unused tabs (ordered media) be outputted to a tray, specified by the user via a GUI, that is different from the first job output. For instance, as shown in the excerpt below, Ricoh TotalFlow configures the printing system to send the first part of the ordered media set directly to a first job output when it specifies that (1) media that includes usage of tabs (ordered media) is to be outputted to one tray and (2) one or more exceptions (i.e., the unused tabs) are sent to a different tray.

Input Trays

The Input Trays pod on the Printer tab lets you enable or disable the printer input trays and edit the paper in the input trays.

Interposer Trays

The Interposer Trays pod on the Printer tab lets you enable or disable the printer interposer trays and edit the paper in the interposer trays.

Output Trays

The Output Trays pod on the Printer tab lets you enable or disable the printer output trays.

Ex. 33 (M2737502_en.pdf at page 33).

336. Claim limitation 1[e] is satisfied for at least the following reasons. Ricoh TotalFlow configures multiple output trays to be used when processing a print job. In this fashion, portions of the ordered media for print can be outputted to a first tray and unused portions of the ordered media can be ejected to a second tray.

337. As shown in the excerpt below, Ricoh TotalFlow configures the printing system to send the first part of the ordered media set directly to a first job output when it specifies that (1) media that includes usage of tabs (ordered media) is to be outputted to one tray and (2) one or more exceptions (i.e., the unused tabs) are sent to a different tray.

Input Trays

The Input Trays pod on the Printer tab lets you enable or disable the printer input trays and edit the paper in the input trays.

Interposer Trays

The Interposer Trays pod on the Printer tab lets you enable or disable the printer interposer trays and edit the paper in the interposer trays.

Output Trays

The Output Trays pod on the Printer tab lets you enable or disable the printer output trays.

Ex. 33 (M2737502_en.pdf at page 33).

338. Ricoh also infringes under the doctrine of equivalents because it meets at least, and by way of example, the following claim limitation(s) of representative Claim 1 by performing substantially the same function as this limitation, performing this function in substantially the same way as this limitation, and achieving substantially the same results as claim limitation 1[e]. For example, and without limitation, Ricoh TotalFlow performs substantially the same function in substantially the same way and achieves substantially the same result at least because it produces a printed end document based on selections received from a GUI which caused portions of a print job, that were to be included in the printed end document, to be routed to a first output tray and the portions to be excluded to a second output tray.

339. As a result of Defendant's unlawful activities, MASA has suffered and will continue to suffer irreparable harm for which there is no adequate remedy at law. Accordingly, MASA is entitled to preliminary and/or permanent injunctive relief.

340. Defendant's infringement of the '9005 Patent has injured and continues to injure MASA in an amount to be proven at trial.

COUNT X

(Direct Infringement of the '278 Patent pursuant to 35 U.S.C. § 271(a))

341. MASA repeats, realleges, and incorporates by reference, as if fully set forth herein, the allegations of the preceding paragraphs, as set forth above.

342. Defendant has infringed and continues to infringe one or more claims of the '278 Patent, including at least claim 1, in violation of 35 U.S.C. § 271(a).

343. Defendant's infringement is based upon literal infringement or infringement under the doctrine of equivalents, or both.

344. Defendant's acts of making, using, importing, selling, and/or offering for sale infringing products and services have been without the permission, consent, authorization, or license of MASA.

345. Defendant's infringement includes the manufacture, use, sale, importation and/or offer for sale of Defendant's products and services, such as Ricoh Aficio MP C2030, C2050, C2530, C2550.

346. Claim 1 of the '278 Patent is recited below:

1[a] Digital printer or copier machine for the single-sided or double-sided printing of a substrate using at least one toner,

1[b] with at least one fixing device for fixing the toner onto the substrate, whereby the fixing device has at least one heating device for fusing the toner, and

1[c] and with at least one transport device, in order to supply the substrate to the heating device, in order to supply the substrate to the heating device, to guide it past the heating device and/or to further transport it from the heating device,

1[d] whereby the transport device has at least one suction belt that has a number of through passage openings and that can be impinged with a vacuum, characterized in that the suction belt is constructed as a mesh having stays forming through-passage openings,

1[e] the entire cross-section flow-through area of said through-passage openings being markedly greater than the entire area of said stays between said through-passage openings.

347. As one example of how the '278 Accused Products infringe at least claim 1, Ricoh Aficio MP C2030 meets the limitations of claim 1 of the '278 Patent for at least the reasons described below.

348. Claim limitation 1[a] is satisfied because Ricoh Aficio MP C2030 is a full color/black networked printer that carry out single-sided or double-sided printing on a substrate, such as paper, using at least one Black toner for black and white printing and additional toners, such as Cyan, Magenta, and Yellow for full color printing. As shown below, Ricoh Aficio Printers and Copiers perform single-sided printing or double-sided printing on a paper that is transported by a feed motor through a print area once for single-sided printing and twice, for double-sided printing.

Basic Operation

2.2.5 ORIGINAL TRANSPORT AND EXIT

Single-Sided Originals

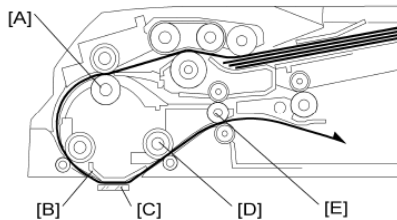

The feed motor feeds the separated original to the skew correction roller [A] at maximum speed. After skew correction, the feed and transport motors feed the original through the scanning area at a lower speed (the scanning area contains the original exposure guide [B] and DF exposure glass [C]). After scanning, the original is fed out by the transport roller [D] and exit roller [E].

Double-Sided Originals

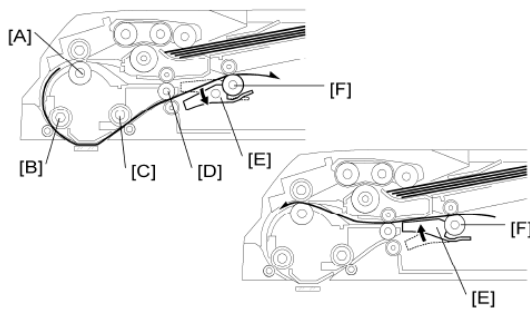

After skew correction, the feed and transport motors drive the skew correction roller [A], registration roller [B], transport roller [C] and the exit roller [D]. The front side of the original is then scanned.

When the original exit sensor detects the leading edge of the original, the junction gate solenoid is activated and the junction gate [E] opens. The original is then transported

towards the inverter table.

Soon after the trailing edge of the original passes the exit sensor, the junction gate solenoid switches off and the junction gate [E] is closed. When the original has been fed onto the inverter table, the feed motor switches on in reverse. The original is then fed by the inverter roller [F], and then by the skew correction roller [A] and registration roller [B] to the scanning area (where the reverse side will be scanned).

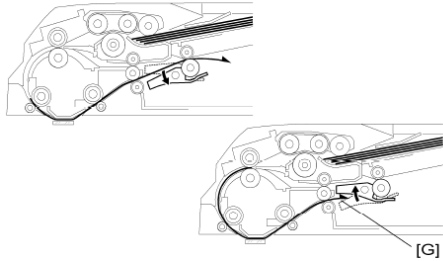

The original is then sent to the inverter table again to be turned over. This is done so that the duplex copies will be properly stacked front side down in the exit tray [G] in the correct order.

Ex. 42 (C2030_C2050_Service_Manual at pp. 954-955).

349. Additionally, as shown below, the control panel screen of Ricoh Aficio MP C2030 displays different color mode options including [K] for Black in Black and White mode, [FC] for full color mode and uses at least one toner for performing Black and White or full color printing of substrates.

Service Program Mode

5.1.4 REMARKS

Display on the Control Panel Screen

The maximum number of characters which can show on the control panel screen is limited to 30 (H-model)/ 17 (L-model) characters. For this reason, some of the SP modes shown on the screen need to be abbreviated. The following are abbreviations used for the SP modes for which the full description is over 30 (H-model)/ 17 (L-model) characters.

<p>Color Mode [Color] [K]: Black in B&W mode [Y], [M], or [C]: Yellow, Magenta, or Cyan in Full Color mode [YMC]: Only for Yellow, Magenta, and Cyan [FC]: Full Color mode [FC, K], [FC, Y], [FC, M], or [FC, C]: Black, Yellow, Magenta, or Cyan in full color mode</p>	
<p>Print Mode S: Simplex D: Duplex</p>	<p>Process Speed L: Low speed (60 mm/s) M: Middle speed (120 mm/s)</p>

Ex. 42 (C2030_C2050_Service_Manual at p. 318).

350. Ricoh Aficio MP C2030 also utilize toner supply motors and development motors for carrying out single-sided or double-sided printing of substrates in black and white or full color by selecting the appropriate toners from amongst the Yellow, Magenta, Cyan and Black toners and therefore, Ricoh Aficio Printers and Copiers perform single-sided or double-sided printing of a substrate using at least one toner, as depicted below:

2.1.3 DRIVE LAYOUT

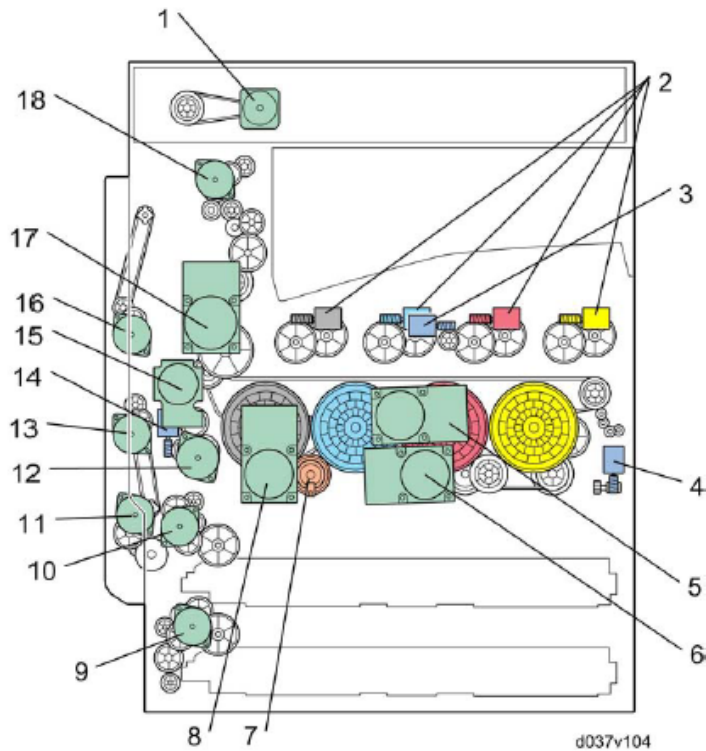

1. Scanner motor	10. Paper feed motor: T1
2. Toner supply motors	11. By-pass motor
3. ITB contact motor	12. Registration motor
4. Used toner collection motor	13. Duplex exit motor
5. Drum motor: CMY	14. PTR contact motor
6. Development motor: CMY	15. ITB unit motor
7. Development clutch: K	16. Duplex entrance motor
8. Drum/Development motor: K	17. Fusing/Paper exit motor
9. Paper feed motor: T2	18. Inverter motor

Ex. 42 (C2030_C2050_Service_Manual at p. 412).

3044	[Toner Supply Type] Toner Supply Type ([Color])		
	Selects the toner supply method type.		
001	Bk	*ENG	[0 to 4 / 4 / 1/step] Alphanumeric 0: FIXED (with the supply rates stored with SP 3401) 1: PID (Vtref_Fixed) 2: PID (Vtref_Control) 3: MBD (Vtref_Fixed) 4: MBD (Vtref_Control)
002	C	*ENG	
003	M	*ENG	
004	Y	*ENG	

Ex. 42 (C2030_C2050_Service_Manual at p. 654).

351. Claim limitation 1[b] is satisfied for at least the following reasons. As shown below, Ricoh Aficio MP C2030 includes a fusing unit which is a fixing device for fixing the toner onto the substrate. Ricoh Aficio MP C2030 meets the recited claim language because the fusing unit includes at least one heating device, such as a fusing roller, heating roller, and a fusing belt for melting the toner and fusing the toner onto the substrate.

352. As shown below, Ricoh Aficio MP C2030 includes a fusing unit, fusing lamp, fusing belt, heating roller, and fusing roller. The fusing lamp shown below heats the fusing roller which in turn melts the toner allowing it to fuse with the substrate.

4.10.7	DRUM/DEVELOPMENT MOTOR: K	4-76
4.10.8	DEVELOPMENT CLUTCH: K	4-77
4.10.9	FUSING/PAPER EXIT MOTOR	4-77
4.11	FUSING	4-80
4.11.1	PM PARTS.....	4-80
4.11.2	FUSING UNIT	4-80
	When installing the fusing unit	4-81
4.11.3	ENTRANCE GUIDE PLATE.....	4-81
	Cleaning Requirement	4-81
4.11.4	STRIPPER PLATE.....	4-82
	Cleaning Requirement	4-83
4.11.5	EXIT GUIDE PLATE CLEANING PROCEDURE	4-84
4.11.6	PRESSURE ROLLER FUSING LAMP.....	4-84
4.11.7	HEATING ROLLER FUSING LAMP	4-86
4.11.8	FUSING BELT	4-87
4.11.9	HEATING, FUSING AND TENSION ROLLER.....	4-90
	When reinstalling the fusing roller	4-91
4.11.10	PRESSURE ROLLER	4-91

4.11 FUSING

4.11.1 PM PARTS

PM Parts	Replacement Procedure
Fusing Roller	☛ Section: Heating, Fusing and Tension Roller
Fusing Belt	☛ Section: Fusing Belt
Thermistor	☛ Section: Heating Roller Thermistor and Section: Pressure Roller Thermistor
Entrance Guide Plate	☛ Section: Entrance Guide Plate
Exit Guide Plate	☛ Section: Exit Guide Plate Cleaning Procedure
Stripper Plate	☛ Section: Stripper Plate
Thermopile	☛ Section: Thermopile

4.11.9 HEATING, FUSING AND TENSION ROLLER

If you install a new fusing roller, set SP 3902-015 to "1" before you start this procedure.

Note

- If you do this, then the machine will reset the PM counter for the fusing unit automatically, after you turn the power on again.

1. Fusing belt with rollers (☛ Section: Fusing Belt)

4.11.7 HEATING ROLLER FUSING LAMP

1. Fusing unit (☛ Section: Fusing Unit)

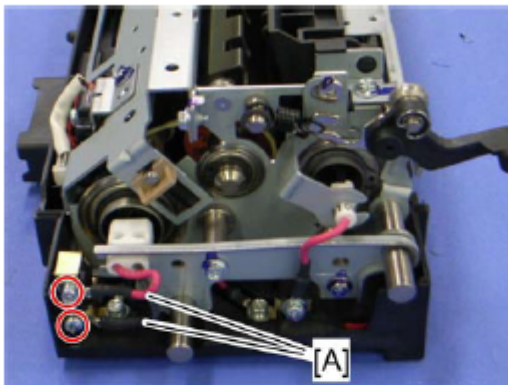

d037r233a

2. Remove the cords [A] from the front stay (☛ x 2)

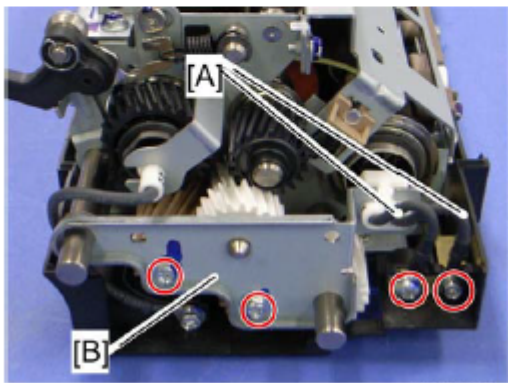

d037r235

3. Remove the cords [A] from the rear stay (☛ x 2)
4. Rear stay [B] (☛ x 2)

Fusing

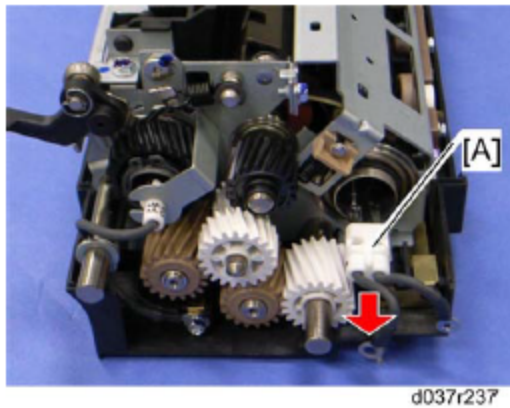

5. Heating roller fusing lamp [A]

Ex. 42 (C2030_C2050_Service_Manual at pp. 20, 251, and 257-258).

353. Ricoh Aficio MP C2030 also includes several heating devices such as fusing belts, heating rollers and fusing rollers that fuse the toner onto the substrate.

13. Bearings [B] of the fusing roller (C x 1 each)

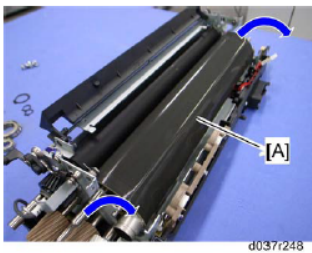

14. Fusing belt [A] with rollers

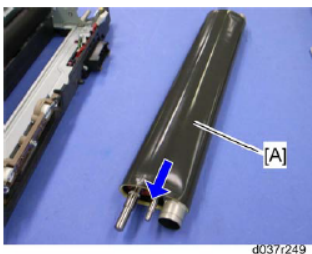

15. Fusing belt [A]

Fusing

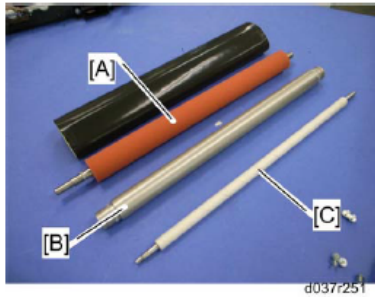

2. Fusing roller [A]
3. Heating roller [B]
4. Tension roller [C]

Ex. 42 (C2030_C2050_Service_Manual at pp. 261-262).

354. Claim limitation 1[c] is satisfied for at least the following reasons. Ricoh Aficio MP C2030 includes a drive unit comprising several transport devices such as motors and belts for transporting the substrate, such as paper, to and from the heating devices, such as the fusing roller, fusing belt and heating roller.

355. As shown below, Ricoh Aficio MP C2030 includes a drive unit for transporting the substrate through the print engine. For example, the drive unit includes paper feed motors T1 and T2 for supplying paper to the fusing unit that includes several heating devices. The fusing/paper exit motors transport the paper through the fusing unit, guide it past the fusing unit, and/or transport it away from the fusing unit.

4.10 DRIVE UNIT

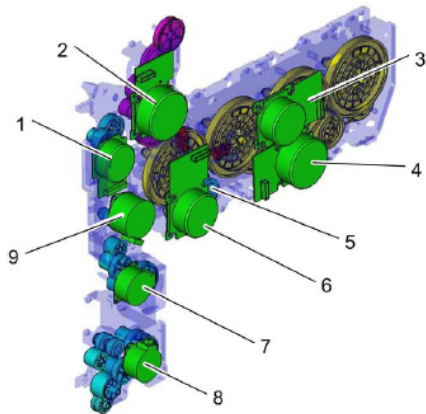

d037r560

The drawing above shows the drive unit layout.

1. ITB drive motor	6. Drum/Development motor: K
2. Fusing/paper exit motor	7. Paper feed motor: T1
3. Drum motor: CMY	8. Paper feed motor: T2
4. Development motor: CMY	9. Registration motor
5. Development clutch: K	

There are some motors and clutches that are not shown in the above drawing:

▪ Duplex inverter motor	▪ Duplex Exit Motor
▪ Duplex Entrance Motor	▪ By-pass Motor

Ex. 42 (C2030_C2050_Service_Manual at p. 243).

356. Ricoh Aficio MP C2030 also includes a fusing belt for transporting the substrate (e.g. paper) to the heating devices and guiding the substrate away from the heating device as shown below.

4.11.8 FUSING BELT

If you install a new fusing belt, set SP 3902-016 to "1" before you start this procedure.

Note

- If you do this, then the machine will reset the PM counter for the fusing belt automatically, after you turn the power on again.

1. Fusing unit (☛ Section: Fusing Unit)
2. Fusing upper cover (☛ Section: Pressure Roller Fusing Lamp)
3. Heating roller fusing lamp (☛ Section: Heating Roller Fusing Lamp)

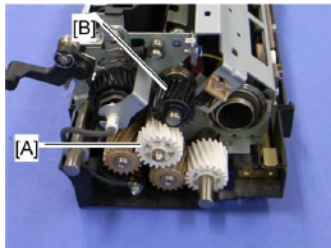

d037r238

4. Idle gear [A] and fusing roller gear [B]

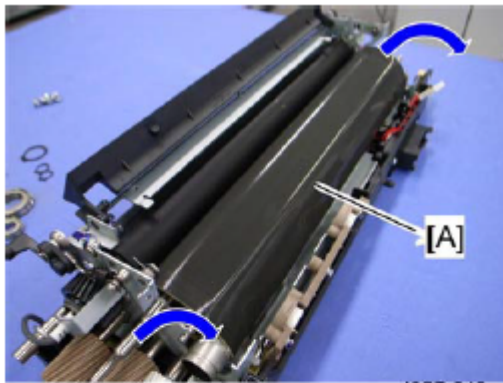

d037r248

14. Fusing belt [A] with rollers

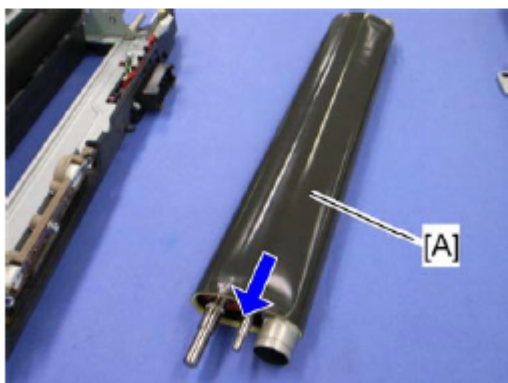

d037r249

15. Fusing belt [A]

Ex. 42 (C2030_C2050_Service_Manual at pp. 258 and 261).

357. Ricoh Aficio MP C2030 further includes at least one transport device, such as an image transfer belt unit (ITBU) [A] shown below, in order to supply the substrate to the heating

device, in order to supply the substrate to the heating device, to guide it past the heating device and/or to further transport it from the heating device.

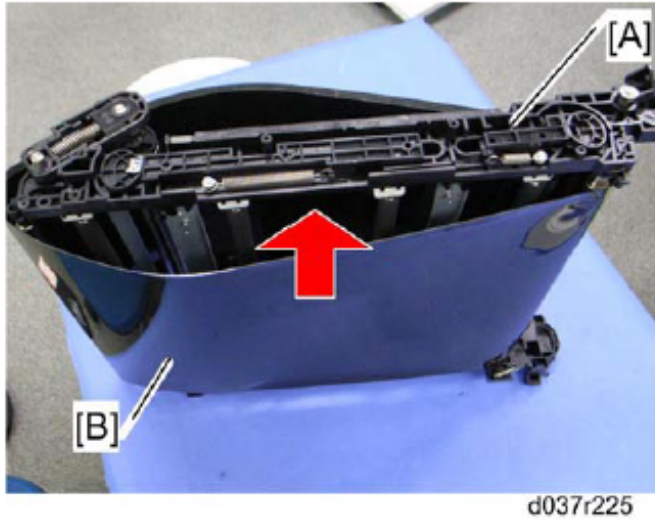

13. Stand the ITB unit [A] as shown above.
14. Image transfer belt [B]

Ex. 42 (C2030_C2050_Service_Manual at pp. 234-235).

358. The ITB unit shown in the image above comprises an image transfer belt (ITB) and an image transfer belt motor (ITBM) reproduced below.

4.8.4 ITB UNIT MOTOR

1. ITB cleaning unit (☛ Section: ITB Cleaning Unit)
2. ITB unit (☛ Section: ITB Unit)

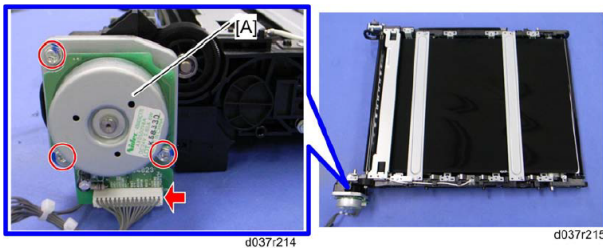

3. ITB unit motor [A] (⌀ x 3, Ⓜ x 1)

4.8.5 IMAGE TRANSFER BELT

1. ITB cleaning unit (☛ Section: ITB Cleaning Unit)
2. ITB unit (☛ Section: ITB Unit)
3. ITB unit motor (☛ Section: ITB Unit Motor)

Image Transfer



4. Two stays [A] (⌀ x 2 each)

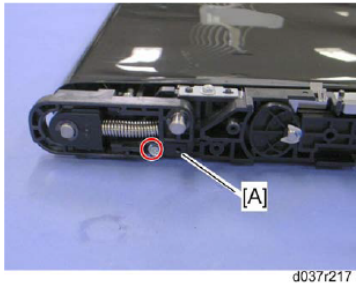

5. Rear holder bracket [A] (as seen from the front) (⌀ x 1: M3x10)

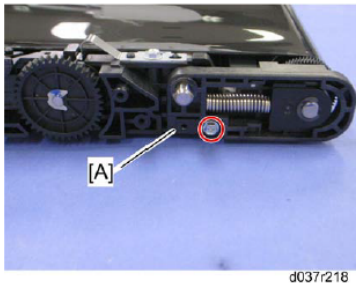

6. Front holder bracket [A] (as seen from the rear) (⌀ x 1: M3x10)

Ex. 42 (C2030_C2050_Service_Manual at pp. 231-235).

359. Claim limitation 1[d] is satisfied for at least the following reasons. The transport device of Ricoh Aficio MP C2030, such as the image transfer belt unit (ITBU), has at least one suction belt, such as the image transfer belt (ITB). The ITB, shown below, comprises a mesh construction with a number of through passage openings that can be impinged with a vacuum. As shown below, the transport device, such as the ITBU [A], has at least one suction belt, such as the ITB [B], that has a number of through passage openings and that can be impinged with a vacuum.

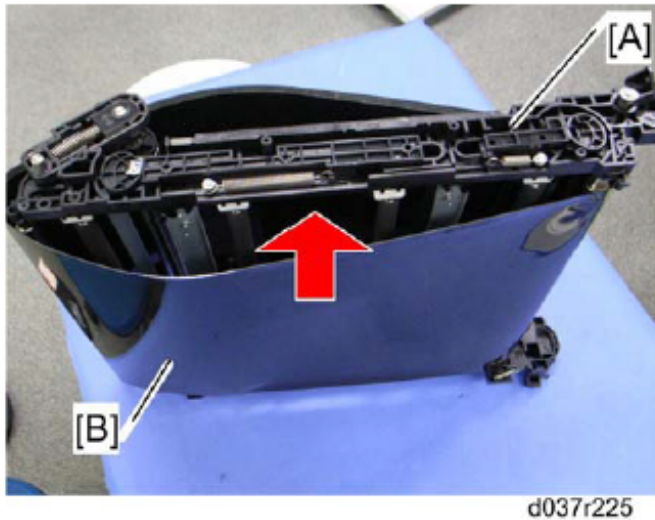

13. Stand the ITB unit [A] as shown above.

14. Image transfer belt [B]

Ex. 42 (C2030_C2050_Service_Manual at pp. 234-235).

Image Transfer



4. Two stays [A] (\varnothing x 2 each)

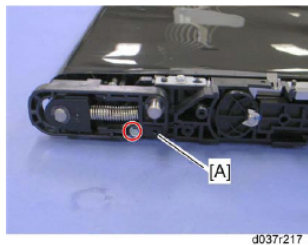

5. Rear holder bracket [A] (as seen from the front) (\varnothing x 1: M3x10)

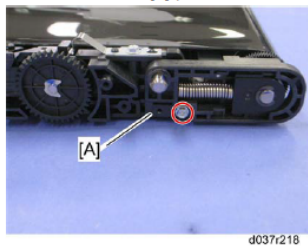

6. Front holder bracket [A] (as seen from the rear) (\varnothing x 1: M3x10)

Ex. 42 (C2030_C2050_Service_Manual at pp. 231-232).

360. Claim limitation 1[e] is satisfied for at least the following reasons. As shown below, the ITB of Ricoh Aficio MP C2030 consists of a mesh-like construction with cross-section flow-through areas of through-passage openings in the ITB appearing to be markedly greater than the entire area of said stays between said through-passage openings.

Image Transfer

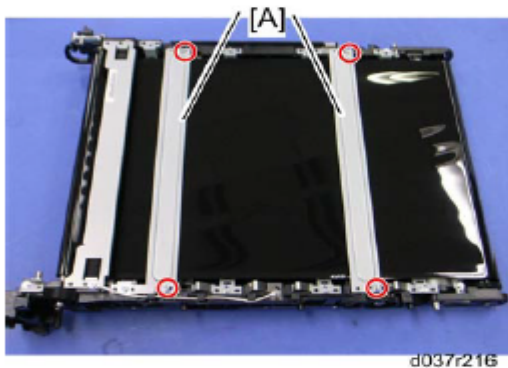

4. Two stays [A] (⌀ x 2 each)

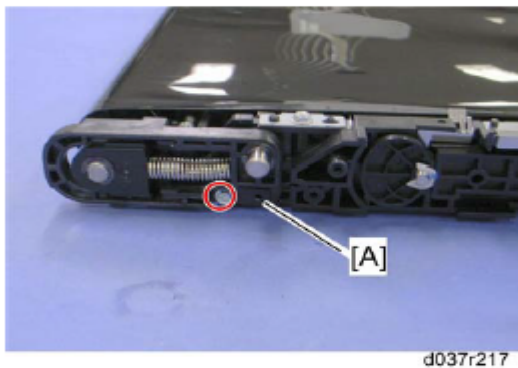

5. Rear holder bracket [A] (as seen from the front) (⌀ x 1: M3x10)

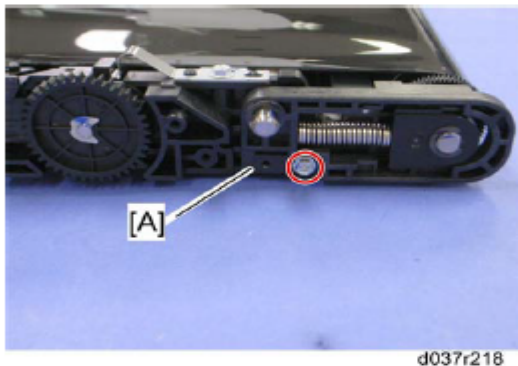

6. Front holder bracket [A] (as seen from the rear) (⌀ x 1: M3x10)

Ex. 42 (C2030_C2050_Service_Manual at pp. 231-232).

361. Ricoh also infringes under the doctrine of equivalents because it meets at least, and by way of example, the following claim limitation(s) of representative Claim 1 by performing substantially the same function as this limitation, performing this function in substantially the same way as this limitation, and achieving substantially the same results as claim limitation 1[d]. For example, and without limitation, Ricoh Aficio MP C2030 performs substantially the same function in substantially the same way and achieves substantially the same result at least because the transport devices of Ricoh Aficio MP C2030, include motors, drive units, image transfer units, and belts (for example, an image transfer belt) that enable secure and reliable transport of paper through the print engine. For example, the image transfer belt of Ricoh Aficio MP C2030 performs substantially the same function of ensuring secure and reliable transport of paper, in substantially the same way by causing the paper to adhere to the image transfer belt during transport and achieves substantially the same result of moving the paper through the print engine.

362. As a result of Defendant's unlawful activities, MASA has suffered and will continue to suffer irreparable harm for which there is no adequate remedy at law. Accordingly, MASA is entitled to preliminary and/or permanent injunctive relief.

363. Defendant's infringement of the '278 Patent has injured and continues to injure MASA in an amount to be proven at trial.

COUNT XI
(Direct Infringement of the '582 Patent pursuant to 35 U.S.C. § 271(a))

364. MASA repeats, realleges, and incorporates by reference, as if fully set forth herein, the allegations of the preceding paragraphs, as set forth above.

365. Defendant has infringed and continues to infringe one or more claims of the '582 Patent, including at least claim 1, in violation of 35 U.S.C. § 271(a).

366. Defendant's infringement is based upon literal infringement or infringement under the doctrine of equivalents, or both.

367. Defendant's acts of making, using, importing, selling, and/or offering for sale infringing products and services have been without the permission, consent, authorization, or license of MASA.

368. Defendant's infringement includes the manufacture, use, sale, importation and/or offer for sale of Defendant's products and services, such as Ricoh Pro C7100x/ C7110x.

369. Claim 1 of the '582 Patent is recited below:

A method of printing to form colored images with improved color gamut and enhanced gloss, the method comprising:

1[a] forming a color print using five or more different color pigments which in combination form at least a pentachrome color image;

1[b] depositing a clear toner overcoat to the at least pentachrome color image, wherein the clear toner overcoat is formed as a receiver and image dependent inverse mask; and

1[c] subjecting the clear toner overcoat and the at least pentachrome color image to a gloss enhancing process.

370. As one example of how the '582 Accused Products infringe at least claim 1, Ricoh Pro C7100X meets the limitations of claim 1 of the '582 Patent for at least the reasons described below.

371. An image of Ricoh Pro C7100X is provided below:



Ex. 47 (Brochure - RICOH Pro C7100-C7100X Series).

372. As a general matter and as explained below, the limitations of claim 1 are satisfied. Ricoh Pro 7100X is a printer that is part of a production color system that improves the color gamut of the standard CMYK (cyan, magenta, yellow, black) pallet of four colors by including a fifth color station which combines colors such as white, neon yellow, and neon pink by the addition of a fifth color.



Change the game with Ricoh's 5th Color Station

Want to achieve a more high-end look, or entice more customers in creative fields? No matter what your goal, Ricoh's white, clear, neon yellow and neon pink toners give you the competitive advantage you need to produce eye-catching work that commands premium prices.

Ex. 48 (PDF of <https://www.ricoh-usa.com/en/products/commercial-industrial-printing/cutsheet/pro-c7100-c7100x-series>)

373. The Ricoh Pro 7100X also includes a Duplo Ultra 300A UV Coater for purposes of improving color images by adding enhanced gloss, as shown below.

Home / Solutions / Finishing / UV Coaters

UV Coaters

Click on a finisher below to learn more about its capabilities.

Sort by: View Per Page:

Duplo Ultra 300A UV Coater

Duplo Ultra 200A UV Coater

Duplo Ultra 100A UV Coater

Ex. 49 (PDF of <http://www.riohbusinessbooster.com/solutions/finishing/uv-coaters/>).



Duplo Ultra 300A UV Coater

Hardware Information

The Ultra 300A UV Coater provide the ideal UV coating solution for any digital print environment. Heavy duty yet simple to use, the Ultra 300A applies a high quality gloss, satin, or matte finish to a wide range of offset and digitally printed applications, adding richness to colors while protecting them from scratches and scuffs.

With a coating speed of up to 148 feet (45 meters) per minute, the Ultra 300A can accommodate the output speed from most digital devices and process a variety of paper sizes, from 8.5" x 11" up to 20" x 28", up to 350 gsm. For near-line feeding, the Ultra 300A is available with the high capacity SF-200 Suction Feeder.

Features

- High speeds up to 148 feet (45 meters) per minute
- Adds gloss, matte, or satin coating
- Infrared Heating System
- UV Coating Low Detection Sensor
- Intelligent Control System for easy operation
- Infrared Heating System helps cure difficult stock
- Auto Gap prevents excess coating from smearing to backside of print

Ex. 50 (PDF of <http://www.ricohbusinessbooster.com/solution/solutions/finishing/uv-coaters/duplo-ultra-300a-uv-coater/>).

374. Claim limitation 1[a] is satisfied for at least the following reasons. As shown below, Ricoh Pro 7100X forms color prints using five color pigments such as the four toners for the standard CMYK pallet of four colors (shown below in a right-to-left, horizontal series of black (K), cyan (C), magenta (M), and yellow (Y) toners), and a fifth toner (identified with the label “S”).

- There are five PCDU s (SYMCK).

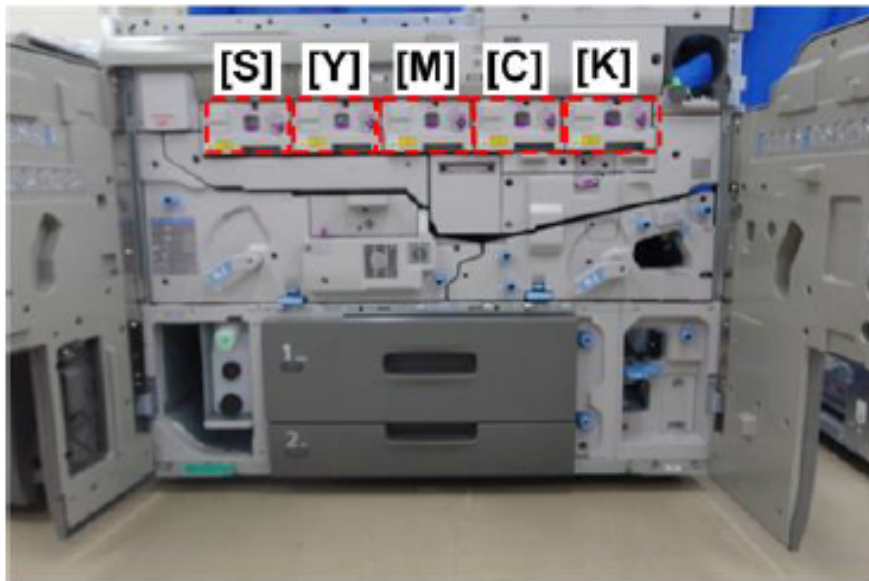

d194d4341

Ex. 51 (Pro C7100, Pro C7110 Series Field Service Manual at p. 891 (893)).

375. Ricoh Pro C7100X uses a fifth station (identified with the label “S” below) to form at least a pentachrome color image such as an image which includes a fifth color, such as neon yellow or neon pink.



Change the game with Ricoh's 5th Color Station

Want to achieve a more high-end look, or entice more customers in creative fields? No matter what your goal, Ricoh's white, clear, neon yellow and neon pink toners give you the competitive advantage you need to produce eye-catching work that commands premium prices.

Ex. 48 (PDF of <https://www.ricoh-usa.com/en/products/commercial-industrial-printing/cutsheet/pro-c7100-c7100x-series>).

376. Claim limitation 1[b] is satisfied for at least the following reasons. As shown below, the fifth station of Ricoh Pro C7100X deposits a clear toner overcoat on a paper during a second pass of a sheet of paper onto which a fused pentachrome image was created during a first pass through the printer.

Tips and Best Practices

1. To achieve optimal image quality and system reliability, settings in the Media Library may need to be adjusted. If you should need assistance contact your local technical support.
2. Creative usage of White and Clear Toners may require more than one pass through the printer. To do so, the media must be physically moved from the output tray back to the input tray, observing proper direction and side placement.
3. One or two layers of White Toner may be applied, with the second layer providing additional opacity and/or brightness.
4. Clear Toner should be applied in a single layer only. Additional layers will not create a 3D effect, but may cause visible yellowing.
5. Clear Toner may be applied inline with CMYK as a single pass. Applying Clear Toner in two passes, with CMYK first and Clear second, may cause a slightly different gloss effect, but may also affect the CMYK color accuracy.
6. Clear and White Toners are sold by the cartridge. Printing with either White or Clear only, does not result in a click-charge.
7. An appropriate Media Catalog entry should be used for all printing of non-white media when using Clear or White Toner. Parameters in the Media Catalog will optimize settings for black, colored, transparent, silver and other non-standard media. Printing without appropriate parameter setup may result in printing errors, such as double feeds and Media jams.
8. If White and CMYK are to be applied to a sheet with no overlap, a single pass may be used. If the CMYK overlaps the White in any areas, two passes must be used, with White being applied in the first pass and the CMYK applied in the second pass.
9. A single file may not contain both a Clear channel and a White channel. If both Clear and White channels are included, the toner type not currently loaded in the machine will be printed in an alternate visible color and cannot be turned off.
10. Setting Adobe Acrobat Preferences to 'Always' Use Overprint Preview is important when printing the 5th Color. This will display the color channel as defined in the PDF and should be reviewed / validated before the print is run.

Ex. 52 (PDF of <http://www.ricohbusinessbooster.com/resource-annex/5th-color-experience/5th-color-video-tutorials/>).

377. As shown below, after the pentachrome color image is fused to paper in the first pass discussed above, one may highlight selected images or specific text with the clear toner

overcoat from which the receiver is formed to add an image dependent inverse mask (as shown by spot tool creating an inverse image). For example, using a spot tool of an illustrator plug-in tool, a spot coating editor enables an area selectable with a few click of a mouse to be coated, as shown below.

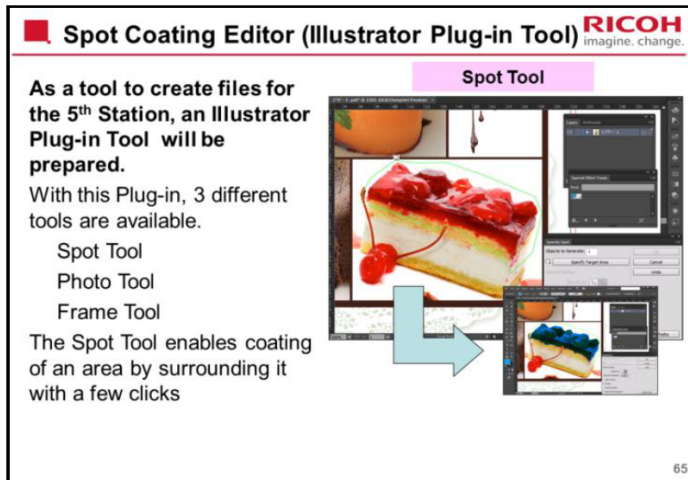

Ex. 53 (RICOH Technical Training Leo-C1/P1 D194/D195/D203/D204 M195/M196/M207/M208 at slide 65).

378. Claim limitation 1[c] is satisfied for at least the following reasons. As shown below, Ricoh Pro C7100X includes a system for subjecting the clear overcoat and the at least a pentachrome color image to a Duplo Ultra 300A UV Coater to add a gloss coating.



Home / Solutions / Finishing / UV Coaters

UV Coaters

Click on a finisher below to learn more about its capabilities.

Sort by: View Per Page:

Duplo Ultra 300A UV Coater

Duplo Ultra 200A UV Coater

Duplo Ultra 100A UV Coater

Ex. 49 (PDF of <http://www.riohbusinessbooster.com/solutions/finishing/uv-coaters/>).



Duplo Ultra 300A UV Coater

Hardware Information

The Ultra 300A UV Coater provide the ideal UV coating solution for any digital print environment. Heavy duty yet simple to use, the Ultra 300A applies a high quality gloss, satin, or matte finish to a wide range of offset and digitally printed applications, adding richness to colors while protecting them from scratches and scuffs.

With a coating speed of up to 148 feet (45 meters) per minute, the Ultra 300A can accommodate the output speed from most digital devices and process a variety of paper sizes, from 8.5" x 11" up to 20" x 28", up to 350 gsm. For near-line feeding, the Ultra 300A is available with the high capacity SF-200 Suction Feeder.

Features

- High speeds up to 148 feet (45 meters) per minute
- Adds gloss, matte, or satin coating
- Infrared Heating System
- UV Coating Low Detection Sensor
- Intelligent Control System for easy operation
- Infrared Heating System helps cure difficult stock
- Auto Gap prevents excess coating from smearing to backside of print

Ex. 50 (PDF of <http://www.riohbusinessbooster.com/solution/solutions/finishing/uv-coaters/duplo-ultra-300a-uv-coater/>).

379. Ricoh also infringes under the doctrine of equivalents because it meets at least, and by way of example, the following claim limitation(s) of representative Claim 1 by

performing substantially the same function as this limitation, performing this function in substantially the same way as this limitation, and achieving substantially the same results as claim limitation 1[a]. For example, and without limitation, Ricoh Pro C7100X perform substantially the same function in substantially the same way and achieves substantially the same result at least because it forms at least a pentachrome color image in a plurality of passes; for example, if a White and CMYK (cyan, magenta, yellow, black) colors are to be applied to a sheet with no overlap, White may be applied in a first pass and the CMYK may be applied in a second pass.

380. As a result of Defendant's unlawful activities, MASA has suffered and will continue to suffer irreparable harm for which there is no adequate remedy at law. Accordingly, MASA is entitled to preliminary and/or permanent injunctive relief.

381. Defendant's infringement of the '582 Patent has injured and continues to injure MASA in an amount to be proven at trial.

COUNT XII
(Direct Infringement of the '375 Patent pursuant to 35 U.S.C. § 271(a))

382. MASA repeats, realleges, and incorporates by reference, as if fully set forth herein, the allegations of the preceding paragraphs, as set forth above.

383. Defendant has infringed and continues to infringe one or more claims of the '375 Patent, including at least claim 1, in violation of 35 U.S.C. § 271(a).

384. Defendant's infringement is based upon literal infringement or infringement under the doctrine of equivalents, or both.

385. Defendant's acts of making, using, importing, selling, and/or offering for sale infringing products and services have been without the permission, consent, authorization or license of MASA.

386. Defendant's infringement includes the manufacture, use, sale, importation and/or offer for sale of Defendant's products and services, such as Ricoh Aficio SP C830DN, C831DN

387. Claim 1 of the '375 Patent is recited below:

A printer comprising:

1[a] a marking mechanism for producing an image on media sheets;

1[b] first and second trays adapted to receive media sheets;

1[c] a sheet feeding mechanism with a drive for advancing media sheets past the marking mechanism, said sheet feeding mechanism having a picker to remove media sheets from trays;

1[d] a media load position for each of said first and second trays at which the trays are accessible to an operator for inserting a supply of media sheets;

1[e] a media pick position for each of said first and second trays at which the trays are aligned with the picker; and

1[f] a mechanism adapted to selectively move each of said first and second trays between its media load position and its pick position, said trays being aligned side by side when both at their pick positions such that the picker can simultaneously remove a sheet from each tray.

388. As one example of how the '375 Accused Products infringe at least claim 1, Ricoh Aficio SP C830DN meets the limitations of claim 1 of the '684 Patent for at least the following reasons.

389. An image of Ricoh Aficio SP C830DN is provided below:



390. As a general matter and as explained below, claim 1 is satisfied because Ricoh Aficio MP C2030 at least comprises a printer.

391. Claim limitation 1[a] is satisfied for at least the following reasons. As shown below, Ricoh Aficio MP C2030 includes a marking mechanism for producing an image on media sheets (such as paper), that includes toner bottles, a laser optics unit, an image transfer belt, a fusing unit and other components shown below. These components of the marking mechanism create an image on media that passes through the printer.

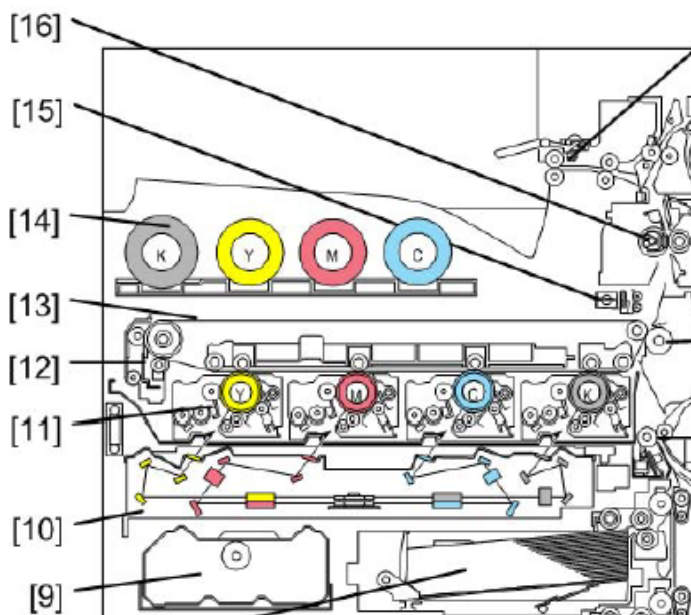

- 9. Toner collection bottle
- 10. Laser optics housing unit
- 11. PCDU (4 colors)
- 12. Image transfer belt cleaning unit
- 13. Image transfer belt unit
- 14. Toner bottle (4 colors)
- 15. ID sensor
- 16. Fusing sleeve belt unit

Ex. 54 (Ricoh_Aficio_SP_C830DN-C831DN.Pdf).

392. Claim limitation 1[b] is satisfied for at least the following reasons. As shown below from an interior and exterior view of the printer, Ricoh Aficio MP C2030 includes assemblies for Trays 1 and 2, which comprise a first and second tray, and are adapted to receive media sheets (e.g., sheets of paper).

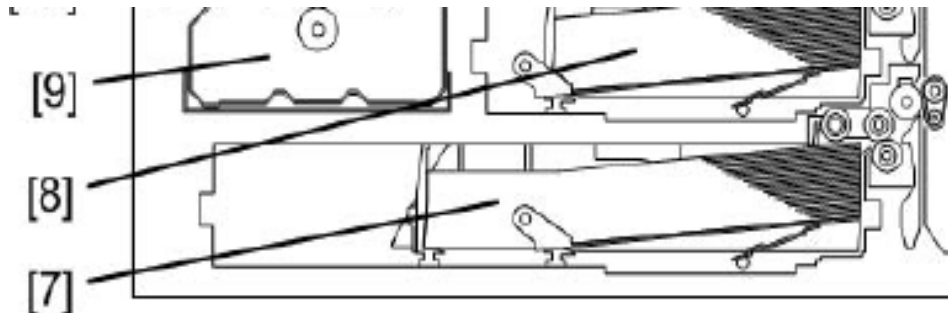

7. Tray 2

8. Tray 1

Ex. 55 (Ricoch_Aficio_SP_C830DN-C831DN.Pdf).



Ex. 54 (Ricoh_Aficio_SP_C830DN-C831DN.Pdf).

393. Claim limitation 1[c] is satisfied for at least the following reasons. As shown below, Ricoh Aficio MP C2030 includes a sheet feeding mechanism (identified as [A] in the image below) with a drive for advancing media sheets past the marking mechanism (described above in connection with limitation 1[a]), whereby the sheet feeding mechanism has a picker to remove media sheets from trays.

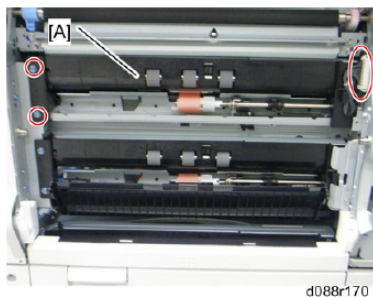

7. Paper feed unit [A] (⌀ x 2, ⌀ x 1)

Pick-Up, Feed and Separation Rollers

Tray 1 and Tray 2

1. Paper feed unit (p.222)

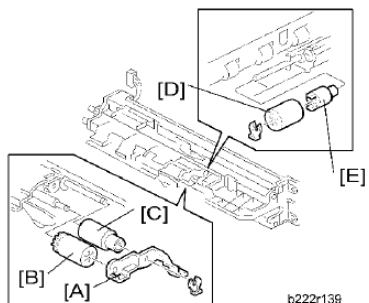

2. Roller holder [A] (⌀ x 1)
3. Pick-up roller [B]
4. Feed roller [C]
5. Separation roller [D] and torque limiter [E] (⌀ x 1)

Ex. 54 (Ricoh_Aficio_SP_C830DN-C831DN.Pdf).

394. Claim limitation 1[d] is satisfied for at least the following reasons. As shown below, Ricoh Aficio MP C2030 includes trays include a media load position for inserting a supply of media sheets – for example, to supply the trays with a stack of paper.

Loading Paper

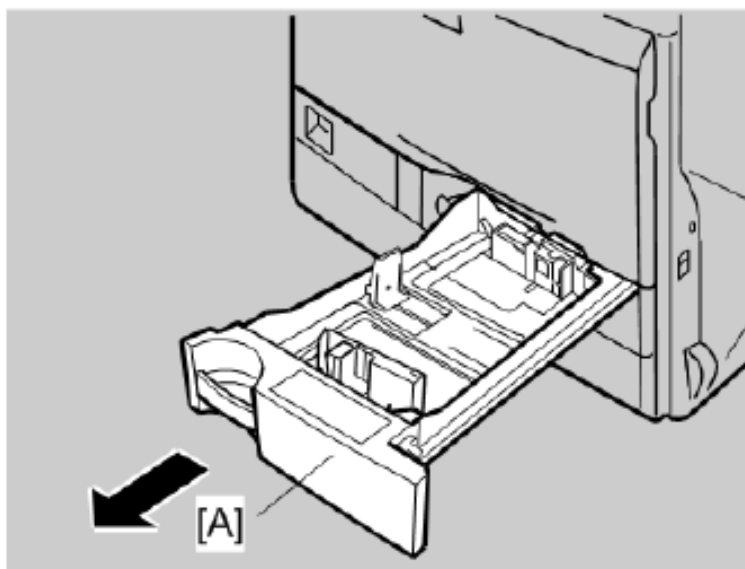

g133i516

Ex. 54 (Ricoh_Aficio_SP_C830DN-C831DN.Pdf).

395. Claim limitation 1[e] is satisfied for at least the following reasons. As shown below, Ricoh Aficio MP C2030 includes a two-tray paper feed unit with a tray lift motor [A] and [B] which aligns trays with the picker in a media pick position.

Tray Lift Motor

1. Rear cover (🔧 p.118)
2. PSU bracket (🔧 p.250)
3. High voltage supply board bracket (🔧 p.254)

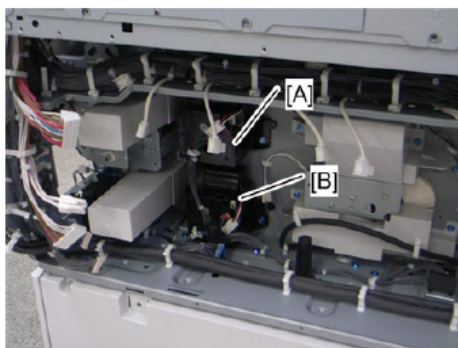

d027r173

4. Tray lift motor 1 [A] or 2 [B] (🔧 x 2, 📦 x 3, 📦 x 1 each)

Ex. 54 (Ricoh_Aficio_SP_C830DN-C831DN.Pdf).

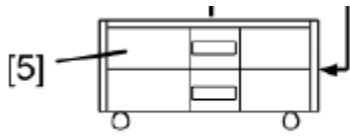

Two-tray paper feed unit	D580	[5]
--------------------------	------	-----

Ex. 54 (Ricoh_Aficio_SP_C830DN-C831DN.Pdf).

396. Claim limitation 1[f] is satisfied for at least the following reasons. As shown below, Ricoh Aficio MP C2030 includes a one-tray or two-tray paper feed unit that includes a clutch [6,7] adapted to selectively move each of said first and second trays (which are aligned side by side as shown above) between its media load position and its pick position. The mechanism for moving each tray is connectable and independent to each tray so as to move one tray at a time from its media load position to its pick position such that the picker can separately or simultaneously remove a sheet from the tray. The sheet feeding mechanism includes a picker [pick-up roller B] to remove media sheets from the trays:

No.	Options	Remarks	
1	One-tray paper feed unit	U	One from No.1, No.2, No.3
2	Two-tray paper feed unit	U	
3	2000-sheet LCT	U	

Ex. 54 (Ricoh_Aficio_SP_C830DN-C831DN.Pdf).

Drive Unit

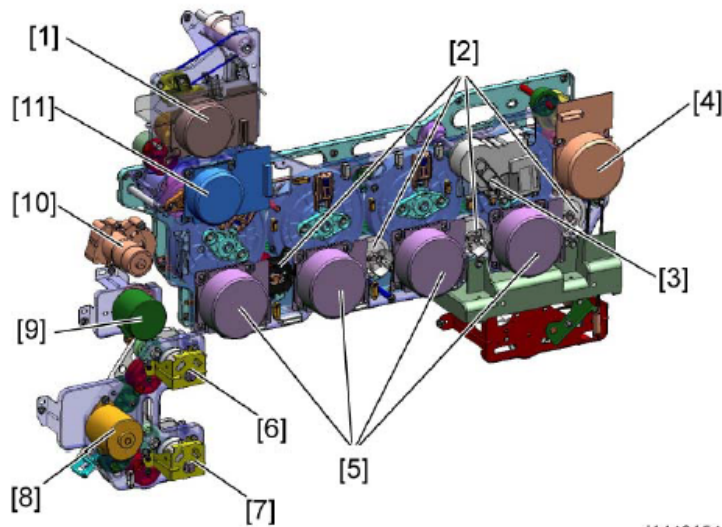

d1440154

The drawing above shows the drive unit layout.

1. Fusing/paper exit motor	7. Paper feed clutch – Tray 2
2. Development clutches	8. Paper feed motor
3. Image transfer belt contact motor	9. Registration motor
4. Toner transport motor	10. Paper transfer contact motor
5. Drum/Development drive motors	11. ITB drive motor
6. Paper feed clutch – Tray 1	

There are some motors and clutches that are not shown in the above drawing:

<ul style="list-style-type: none"> • Tray lift motor 1 and 2 • Duplex inverter motor • Duplex/By-pass Motor 	<ul style="list-style-type: none"> • Junction gate 1 motor • Shutter motor • By-pass clutch
----------------------------------------------------------------------------------------------------------------------------------------------	------------------------------------------------------------------------------------------------------------------------------

Ex. 54 (Ricoh_Aficio_SP_C830DN-C831DN.Pdf).

Pick-Up, Feed and Separation Rollers

Tray 1 and Tray 2

1. Paper feed unit (☞ p.222)

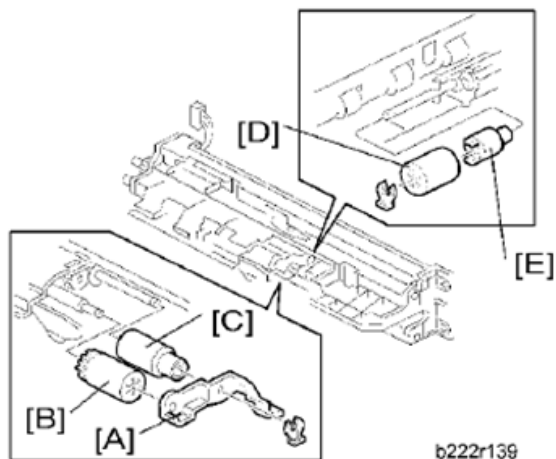

2. Roller holder [A] (☞ x 1)
3. Pick-up roller [B]
4. Feed roller [C]
5. Separation roller [D] and torque limiter [E] (☞ x 1)

Ex. 54 (Ricoh_Aficio_SP_C830DN-C831DN.Pdf).

397. Ricoh also infringes under the doctrine of equivalents because it meets at least, and by way of example, the following claim limitation (s) of representative Claim 1 by performing substantially the same function as this limitation, performing this function in substantially the same way as this limitation, and achieving substantially the same results as claim limitation 1[f]. For example, and without limitation, Ricoh Aficio MP C2030 performs substantially the same function in substantially the same way and achieves substantially the same result at least because it changes the spacing between the paper trays and the picker so that the picker can remove a sheet of paper from the paper supply in the same way and to achieve the same result at the recited claim.

398. As a result of Defendant's unlawful activities, MASA has suffered and will continue to suffer irreparable harm for which there is no adequate remedy at law. Accordingly, MASA is entitled to preliminary and/or permanent injunctive relief.

399. Defendant's infringement of the '375 Patent has injured and continues to injure MASA in an amount to be proven at trial.

COUNT XIII

(Direct Infringement of the '425 Patent pursuant to 35 U.S.C. § 271(a))

400. MASA repeats, realleges, and incorporates by reference, as if fully set forth herein, the allegations of the preceding paragraphs, as set forth above.

401. Defendant has infringed and continues to infringe one or more claims of the '425 Patent, including at least claim 1, in violation of 35 U.S.C. § 271(a).

402. Defendant's infringement is based upon literal infringement or infringement under the doctrine of equivalents, or both.

403. Defendant's acts of making, using, importing, selling, and/or offering for sale infringing products and services have been without the permission, consent, authorization, or license of MASA.

404. Defendant's infringement includes the manufacture, use, sale, importation and/or offer for sale of Defendant's products and services, such as Ricoh Pro C7100x/ C7110x.

405. Claim 1 of the '425 Patent is recited below:

In a tandem color electrostatographic printer apparatus having five or more color printing stations for applying respective color separation toner images to a receiver member, a method of forming a pentachrome color image comprising:

1[a] passing a receiver member through the printer apparatus to serially deposit thereon in a single pass at least five different colors which form various combinations of color at different pixel locations to form a pentachrome image thereon;

1[b] a first fusing step of fusing the pentachrome image by passing the receiver member through a fuser station;

1[c] passing the receiver member a second time through the printer apparatus, and depositing a clear toner overcoat to the fused pentachrome toner image; and

1[d] a second fusing step of passing the receiver member with the clear toner overcoat and fused pentachrome toner image again through the aforementioned fuser station to fix the clear toner overcoat to the receiver member.

406. As one example of how the '425 Accused Products infringe at least claim 1, Ricoh Pro C7100X meets the limitations of claim 1 of the '425 Patent for at least the reasons described below.

407. An image of Ricoh Pro C7100X is provided below:



Ex. 47 (Brochure - RICOH Pro C7100-C7100X Series).

408. As a general matter and as described below, the limitations of claim 1 are satisfied because Ricoh Pro C7100X is a printer apparatuses. Ricoh Pro C7100X has five dry ink print stations indicative of electrostatographic printers that include five horizontally-disposed, tandem print stations having four toners for the standard CMYK pallet of four colors (shown below in a right-to-left, horizontal series of black (K), cyan (C), magenta (M), and yellow (Y) toners), and a fifth toner (identified with the label “S”). The stations of the CMYKS

colored toners apply a respective color separation toner image that is received by a receiver member, where the receiver member is a sheet of paper passing along a path (shown as the dark path below the five stations) to form a pentachrome color image.

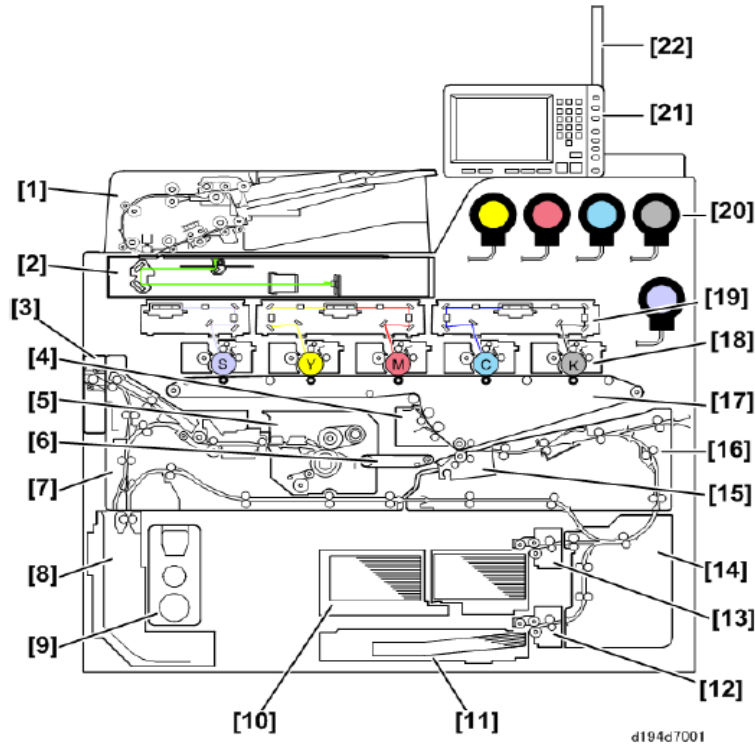

No.	Item	No.	Item
1	ADF (D194/D195/D203/D204 only)	12	PFU (Tray 2)

No.	Item	No.	Item
2	Scanner Unit (D194/D195/D203/D204 only)	13	PFU (Tray 1)
3	Decurl Unit (option)	14	Vertical Transport Unit
4	ITB Cleaning Unit	15	Paper Transfer Roller (PTR) Unit
5	Fuser Unit	16	Right Drawer
6	Paper Transport Belt (PTB) Unit	17	ITB Unit
7	Left Drawer	18	PCDUs
8	Duplex/Purge	19	Laser Units
9	Used Toner Bottle	20	Toner Bank
10	Tray 1 (Tandem Tray)	21	Operation Panel
11	Tray 2 (Universal Tray)	22	Attention Light

Ex. 51 (Pro C7100, Pro C7110 Series Field Service Manual at p. 63-64 (65-66)).

409. Ricoh Pro C7100x includes a fifth color of the fifth toner (identified with the label “S” above) that could include one of the colors of white, clear, neon yellow, and neon pink.



Change the game with Ricoh's 5th Color Station

Want to achieve a more high-end look, or entice more customers in creative fields? No matter what your goal, Ricoh's white, clear, neon yellow and neon pink toners give you the competitive advantage you need to produce eye-catching work that commands premium prices.

Ex. 48 (PDF of <https://www.ricoh-usa.com/en/products/commercial-industrial-printing/cutsheet/pro-c7100-c7100x-series>).

410. Claim limitation 1[a] is satisfied for at least the following reasons. As shown below, Ricoh Pro 7100X passes a receiver member such as a sheet of paper that through the printer along a path (shown as the dark path) below the five horizontally-disposed, serial print stations labeled “S”, “Y”, “M”, “C”, and “K” in a single pass.

- There are five PCDU_s (SYMCK).

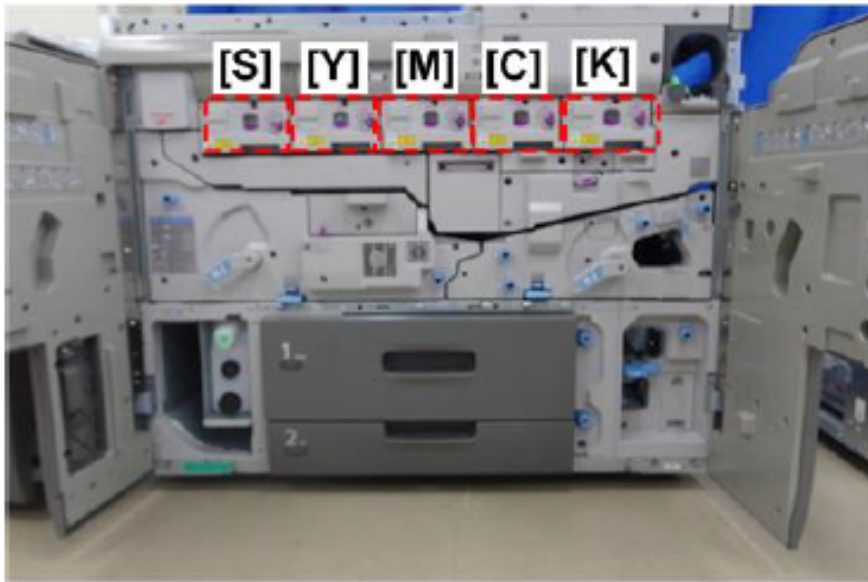

d194d4341

Ex. 51 (Pro C7100, Pro C7110 Series Field Service Manual at p. 891 (893)).

411. Additionally, Ricoh Pro C7100x allows for various combinations of color that are formed at different pixel locations to form a pentachrome image.



Ex. 51 (Pro C7100, Pro C7110 Series Field Service Manual at p. 164 (166)).

412. Claim limitation 1[b] is satisfied for at least the following reasons. As shown below, the Ricoh Pro 7100X provides that the sheet of paper upon which there is a pentachrome

toner image is passed to a fusing station such as a fuser unit (item 5 below) for fusing the image to the sheet as it passes through the printer.

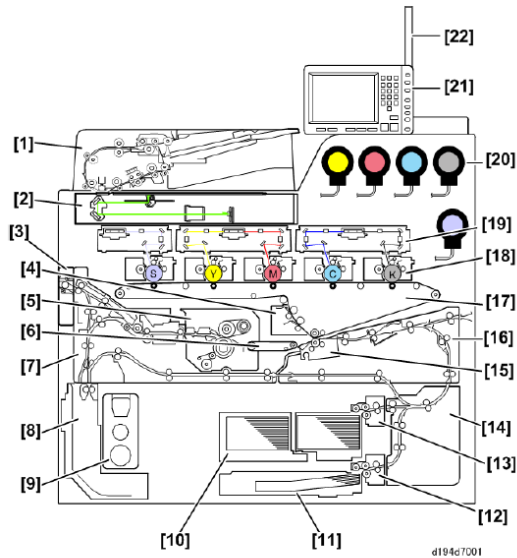

No.	Item	No.	Item
1	ADF (D194/D195/D203/D204 only)	12	PFU (Tray 2)

No.	Item	No.	Item
2	Scanner Unit (D194/D195/D203/D204 only)	13	PFU (Tray 1)
3	Decurl Unit (option)	14	Vertical Transport Unit
4	ITB Cleaning Unit	15	Paper Transfer Roller (PTR) Unit
5	Fuser Unit	16	Right Drawer
6	Paper Transport Belt (PTB) Unit	17	ITB Unit
7	Left Drawer	18	PCDUs
8	Duplex/Purge	19	Laser Units
9	Used Toner Bottle	20	Toner Bank
10	Tray 1 (Tandem Tray)	21	Operation Panel
11	Tray 2 (Universal Tray)	22	Attention Light

Ex. 51 (Pro C7100, Pro C7110 Series Field Service Manual at pp. 63-64 (65-66)).

413. Claim limitation 1[c] is satisfied for at least the following reasons. As shown below, Ricoh Pro 7100X includes a fifth station that deposits on more than one pass, such as on a second pass, a clear toner overcoat on the received member, such as a sheet of paper, after clear toner is inserted into the fifth station.

Tips and Best Practices

1. To achieve optimal image quality and system reliability, settings in the Media Library may need to be adjusted. If you should need assistance contact your local technical support.
2. Creative usage of White and Clear Toners may require more than one pass through the printer. To do so, the media must be physically moved from the output tray back to the input tray, observing proper direction and side placement.
3. One or two layers of White Toner may be applied, with the second layer providing additional opacity and/or brightness.
4. Clear Toner should be applied in a single layer only. Additional layers will not create a 3D effect, but may cause visible yellowing.
5. Clear Toner may be applied inline with CMYK as a single pass. Applying Clear Toner in two passes, with CMYK first and Clear second, may cause a slightly different gloss effect, but may also affect the CMYK color accuracy.
6. Clear and White Toners are sold by the cartridge. Printing with either White or Clear only, does not result in a click-charge.
7. An appropriate Media Catalog entry should be used for all printing of non-white media when using Clear or White Toner. Parameters in the Media Catalog will optimize settings for black, colored, transparent, silver and other non-standard media. Printing without appropriate parameter setup may result in printing errors, such as double feeds and Media jams.
8. If White and CMYK are to be applied to a sheet with no overlap, a single pass may be used. If the CMYK overlaps the White in any areas, two passes must be used, with White being applied in the first pass and the CMYK applied in the second pass.
9. A single file may not contain both a Clear channel and a White channel. If both Clear and White channels are included, the toner type not currently loaded in the machine will be printed in an alternate visible color and cannot be turned off.
10. Setting Adobe Acrobat Preferences to 'Always' Use Overprint Preview is important when printing the 5th Color. This will display the color channel as defined in the PDF and should be reviewed / validated before the print is run.

Ex. 52 (PDF of <http://www.riohbusinessbooster.com/resource-annex/5th-color-experience/5th-color-video-tutorials/>).

414. Claim limitation 1[d] is satisfied for at least the following reasons. As shown below, the Ricoh Pro 7100X permits a sheet of paper, upon which there is clear toner deposited onto a fused pentachrome toner image, to be passed to the fusing station such as a fuser unit (item 5 below) for fusing the clear toner to the fused pentachrome toner image.

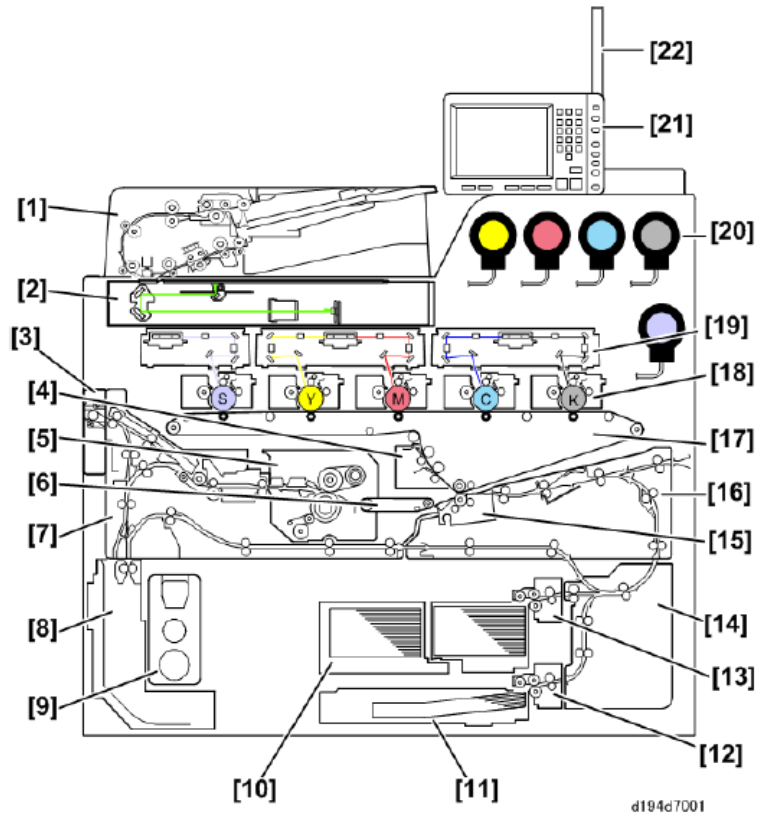

No.	Item	No.	Item
1	ADF (D194/D195/D203/D204 only)	12	PFU (Tray 2)

No.	Item	No.	Item
2	Scanner Unit (D194/D195/D203/D204 only)	13	PFU (Tray 1)
3	Decurl Unit (option)	14	Vertical Transport Unit
4	ITB Cleaning Unit	15	Paper Transfer Roller (PTR) Unit
5	Fuser Unit	16	Right Drawer
6	Paper Transport Belt (PTB) Unit	17	ITB Unit
7	Left Drawer	18	PCDU's
8	Duplex/Purge	19	Laser Units
9	Used Toner Bottle	20	Toner Bank
10	Tray 1 (Tandem Tray)	21	Operation Panel
11	Tray 2 (Universal Tray)	22	Attention Light

Ex. 51 (Pro C7100, Pro C7110 Series Field Service Manual at pp. 63-64 (65-66)).

415. Ricoh also infringes under the doctrine of equivalents because it meets at least, and by way of example, the following claim limitation(s) of representative Claim 1 by performing substantially the same function as this limitation, performing this function in substantially the same way as this limitation, and achieving substantially the same results as claim limitation 1[a]. For example, and without limitation, Ricoh Pro C7100X perform substantially the same function in substantially the same way and achieves substantially the same result at least because it serially deposits five different colors on a receiver by serially depositing five different colors on an image transfer belt unit.

416. As a result of Defendant's unlawful activities, MASA has suffered and will continue to suffer irreparable harm for which there is no adequate remedy at law. Accordingly, MASA is entitled to preliminary and/or permanent injunctive relief.

417. Defendant's infringement of the '425 Patent has injured and continues to injure MASA in an amount to be proven at trial.

COUNT XIV
(Direct Infringement of the '415 Patent pursuant to 35 U.S.C. § 271(a))

418. MASA repeats, realleges, and incorporates by reference, as if fully set forth herein, the allegations of the preceding paragraphs, as set forth above.

419. Defendant has infringed and continues to infringe one or more claims of the '415 Patent, including at least claim 1, in violation of 35 U.S.C. § 271(a).

420. Defendant's infringement is based upon literal infringement or infringement under the doctrine of equivalents, or both.

421. Defendant's acts of making, using, importing, selling, and/or offering for sale infringing products and services have been without the permission, consent, authorization, or license of MASA.

422. Defendant's infringement includes the manufacture, use, sale, importation and/or offer for sale of Defendant's products and services, such as Ricoh Pro C7100x/ C7110x.

423. Claim 1 of the '415 Patent is recited below:

A system for printing color images comprising:

1[a] a tandem color electrostatographic printer apparatus having five or more color printing stations for applying respective color separation toner images to a receiver member passing therethrough in a single pass to form a pentachrome color image;

1[b] a fusing station for fusing the pentachrome image;

1[c] a clear toner overcoat printing station for applying a clear toner overcoat to the fused pentachrome toner image; and

1[d] a belt glosser for providing enhanced gloss to the pentachrome color image having a clear overcoat.

424. As one example of how the '415 Accused Products infringe at least claim 1, Ricoh Pro C7100x meets the limitations of claim 1 of the '415 Patent for at least the reasons described below.

425. An image of Ricoh Pro C7100x is provided below:



Ex. 47 (Brochure - RICOH Pro C7100-C7100X Series).

426. As a general matter and as described below, the limitations of claim 1 are satisfied because Ricoh Pro C7100x is a system for printing color images in that they are production color system which includes a printer.

427. Claim limitation 1[a] is satisfied for at least the following reasons. As shown below, Ricoh Pro C7100x has five dry ink print stations (labeled “S”, “Y”, “M”, “C”, and “K”) indicative of an electrostatographic printer apparatuses that have five horizontally-disposed, tandem print stations having four toners for the standard CMYK pallet of four colors (shown below in a right-to-left, horizontal series of black (K), cyan (C), magenta (M), and yellow (Y) toners), and a fifth toner (identified with the label “S”). Each station of the CMYKS colored toners applies a color separation toner image that is received by a receiver member, where the receiver member could be a sheet of paper passing along a path (shown as the dark path below the five stations) to form a pentachrome color image.

- There are five PCDU s (SYMCK).

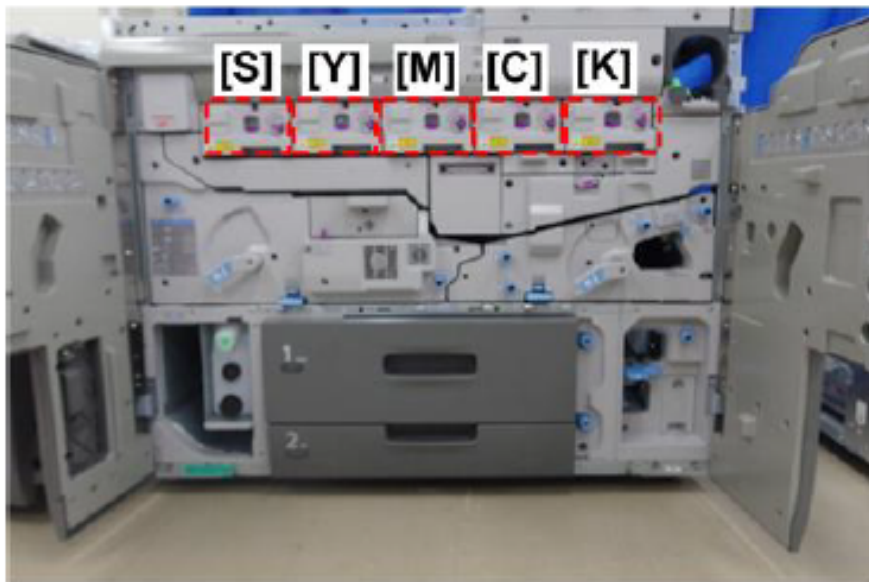

d194d4341

Ex. 51 (Pro C7100, Pro C7110 Series Field Service Manual at p. 891 (893)).

428. Claim limitation 1[b] is satisfied for at least the following reasons. As shown below, Ricoh Pro C7100x includes a fuser unit (item 5) (a fusing station) that fuses a pentachrome image printed on paper at the toner image transfer area after the paper has made a first pass through the printer.

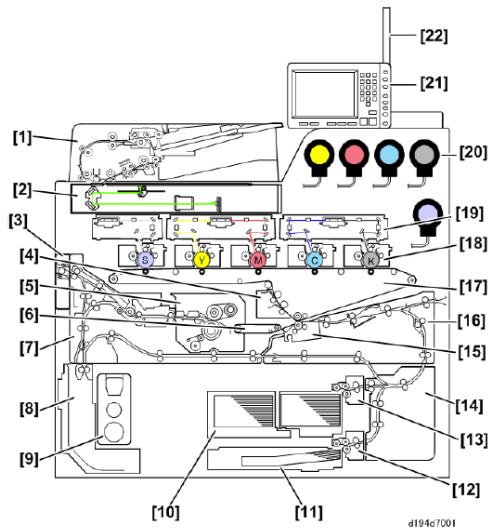

No.	Item	No.	Item
2	Scanner Unit (D194/D195/D203/D204 only)	13	PFU (Tray 1)
3	Decurl Unit (option)	14	Vertical Transport Unit
4	ITB Cleaning Unit	15	Paper Transfer Roller (PTR) Unit
5	Fuser Unit	16	Right Drawer
6	Paper Transport Belt (PTB) Unit	17	ITB Unit
7	Left Drawer	18	PCDU's
8	Duplex/Purge	19	Laser Units
9	Used Toner Bottle	20	Toner Bank
10	Tray 1 (Tandem Tray)	21	Operation Panel
11	Tray 2 (Universal Tray)	22	Attention Light

Ex. 51 (Pro C7100, Pro C7110 Series Field Service Manual at p. 63 (65)).

429. Claim limitation 1[c] is satisfied for at least the following reasons. As shown below, Ricoh Pro C7100x includes a receiver with a fused pentachrome toner image comprised of CMYK and white toner colors that may be physically removed after a first pass through the printer. After replacing the white toner for clear toner in the fifth station, the receiver may be placed into position for a second pass where the clear toner is applied as an overcoat onto the fused pentachrome toner image. Ricoh Pro C7100x has a fifth station that may provide a clear toner overcoat with clear toner being inserted into the fifth station.

Tips and Best Practices

1. To achieve optimal image quality and system reliability, settings in the Media Library may need to be adjusted. If you should need assistance contact your local technical support.
2. Creative usage of White and Clear Toners may require more than one pass through the printer. To do so, the media must be physically moved from the output tray back to the input tray, observing proper direction and side placement.
3. One or two layers of White Toner may be applied, with the second layer providing additional opacity and/or brightness.
4. Clear Toner should be applied in a single layer only. Additional layers will not create a 3D effect, but may cause visible yellowing.
5. Clear Toner may be applied inline with CMYK as a single pass. Applying Clear Toner in two passes, with CMYK first and Clear second, may cause a slightly different gloss effect, but may also affect the CMYK color accuracy.
6. Clear and White Toners are sold by the cartridge. Printing with either White or Clear only, does not result in a click-charge.
7. An appropriate Media Catalog entry should be used for all printing of non-white media when using Clear or White Toner. Parameters in the Media Catalog will optimize settings for black, colored, transparent, silver and other non-standard media. Printing without appropriate parameter setup may result in printing errors, such as double feeds and Media jams.
8. If White and CMYK are to be applied to a sheet with no overlap, a single pass may be used. If the CMYK overlaps the White in any areas, two passes must be used, with White being applied in the first pass and the CMYK applied in the second pass.
9. A single file may not contain both a Clear channel and a White channel. If both Clear and White channels are included, the toner type not currently loaded in the machine will be printed in an alternate visible color and cannot be turned off.
10. Setting Adobe Acrobat Preferences to 'Always' Use Overprint Preview is important when printing the 5th Color. This will display the color channel as defined in the PDF and should be reviewed / validated before the print is run.

Ex. 52 (PDF of <http://www.riohbusinessbooster.com/resource-annex/5th-color-experience/5th-color-video-tutorials/>).



Change the game with Ricoh's 5th Color Station

Want to achieve a more high-end look, or entice more customers in creative fields? No matter what your goal, Ricoh's white, clear, neon yellow and neon pink toners give you the competitive advantage you need to produce eye-catching work that commands premium prices.

Ex. 48 (PDF of <https://www.rioh-usa.com/en/products/commercial-industrial-printing/cutsheet/pro-c7100-c7100x-series>).

430. Claim limitation 1[d] is satisfied for at least the following reasons. Ricoh Pro C7100x includes a Duplo Ultra 300A UV Coater, as shown below, that has a belt glosser such as the belt that is moving within the unit. The Duplo Ultra 300A UV Coater can also add an enhanced gloss toner, such as the gloss toner of a gloss coating.

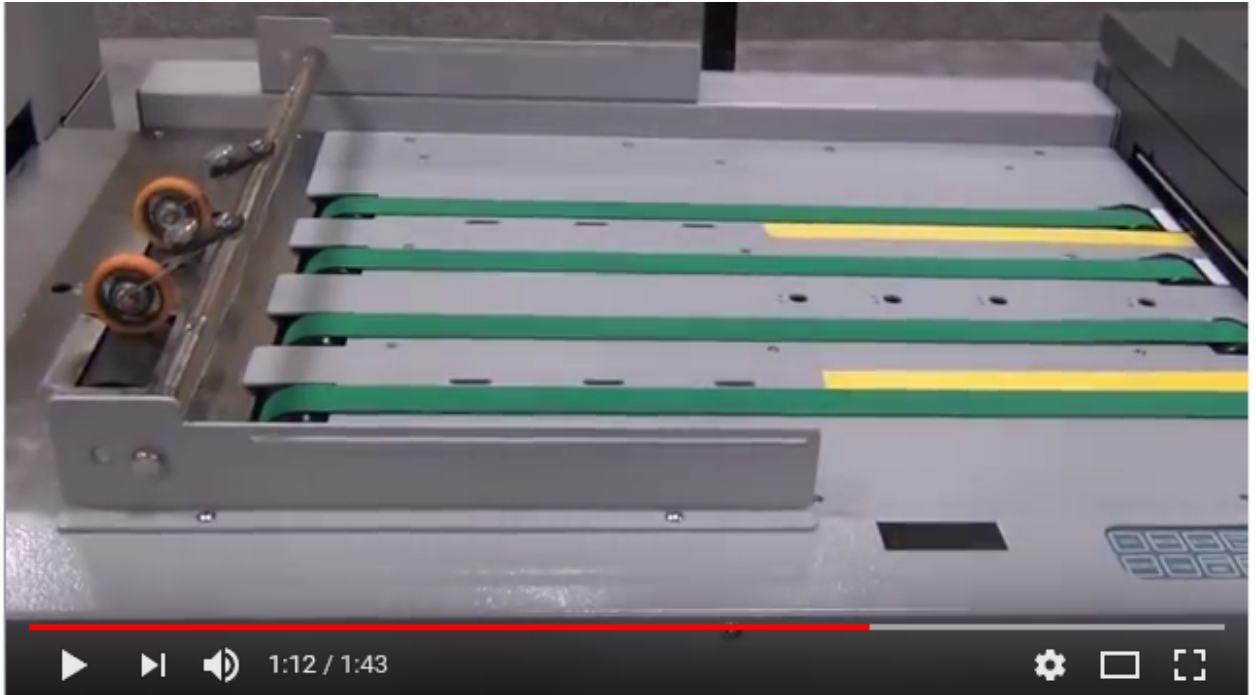

Ex. 59 (PDF of <https://youtu.be/2LgAsSfcVbM?t=72>).

[Home](#) / [Solutions](#) / [Finishing](#) / [UV Coaters](#)

UV Coaters

Click on a finisher below to learn more about its capabilities.

Sort by: View Per Page:

[Duplo Ultra 300A UV Coater](#)

[Duplo Ultra 200A UV Coater](#)

[Duplo Ultra 100A UV Coater](#)

Ex. 49 (PDF of <http://www.riohbusinessbooster.com/solutions/finishing/uv-coaters/>).

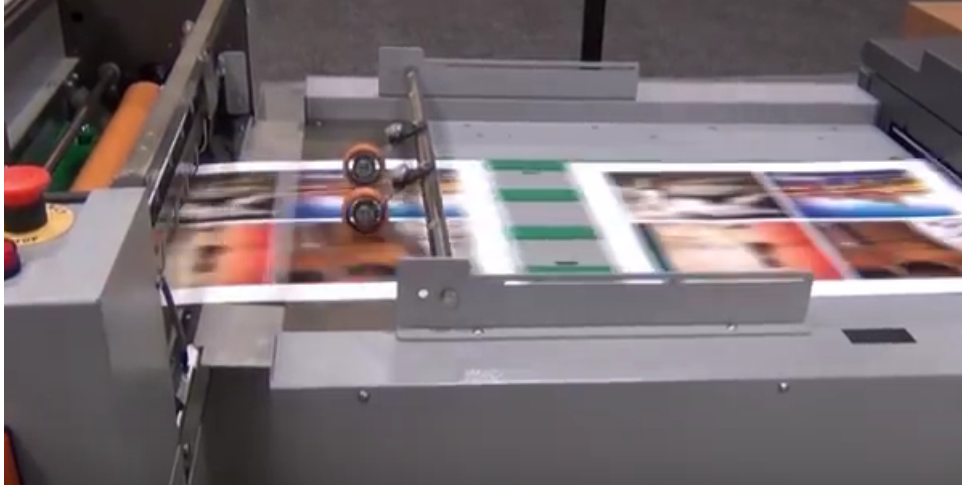

Ex. 55 (PDF of Duplo Ultra 300Ai High Speed UV Coater video presentation (*see* <https://youtu.be/2LgAsSfcVbM?t=21>) (showing a moving belt transporting paper within a Duplo Ultra 300Ai UV Coater at time 0:21 / 1:43)).



Duplo Ultra 300A UV Coater

Hardware Information

The Ultra 300A UV Coater provide the ideal UV coating solution for any digital print environment. Heavy duty yet simple to use, the Ultra 300A applies a high quality gloss, satin, or matte finish to a wide range of offset and digitally printed applications, adding richness to colors while protecting them from scratches and scuffs.

With a coating speed of up to 148 feet (45 meters) per minute, the Ultra 300A can accommodate the output speed from most digital devices and process a variety of paper sizes, from 8.5" x 11" up to 20" x 28", up to 350 gsm. For near-line feeding, the Ultra 300A is available with the high capacity SF-200 Suction Feeder.

Features

- High speeds up to 148 feet (45 meters) per minute
- Adds gloss, matte, or satin coating
- Infrared Heating System
- UV Coating Low Detection Sensor
- Intelligent Control System for easy operation
- Infrared Heating System helps cure difficult stock
- Auto Gap prevents excess coating from smearing to backside of print

Ex. 50 (<http://www.riohbusinessbooster.com/solution/solutions/finishing/uv-coaters/duplo-ultra-300a-uv-coater/>).

431. Ricoh also infringes under the doctrine of equivalents because it meets at least, and by way of example, the following claim limitation(s) of representative Claim 1 by performing substantially the same function as this limitation, performing this function in substantially the same way as this limitation, and achieving substantially the same results as claim limitations 1[c]. For example, and without limitation, Ricoh Pro C7100X perform substantially the same function in substantially the same way and achieves substantially the same result at least because the clear toner overcoat printing station is one of the five color printing stations used to form a pentachrome image, where color toner installed at one of the five stations used to form the pentachrome image in a first pass may be substituted with clear toner that is applied to a fused pentachrome image during a second pass.

432. As a result of Defendant's unlawful activities, MASA has suffered and will continue to suffer irreparable harm for which there is no adequate remedy at law. Accordingly, MASA is entitled to preliminary and/or permanent injunctive relief.

433. Defendant's infringement of the '415 Patent has injured and continues to injure MASA in an amount to be proven at trial.

COUNT XV

(Direct Infringement of the '255 Patent pursuant to 35 U.S.C. § 271(a))

434. MASA repeats, realleges, and incorporates by reference, as if fully set forth herein, the allegations of the preceding paragraphs, as set forth above.

435. Defendant has infringed and continues to infringe one or more claims of the '255 Patent, including at least claim 1, in violation of 35 U.S.C. § 271(a).

436. Defendant's infringement is based upon literal infringement or infringement under the doctrine of equivalents, or both.

437. Defendant's acts of making, using, importing, selling, and/or offering for sale infringing products and services have been without the permission, consent, authorization, or license of MASA.

438. Defendant's infringement includes the manufacture, use, sale, importation and/or offer for sale of Defendant's products and services, such as Ricoh Aficio SP C830DN, C831DN.

439. Claim 1 of the '255 Patent is recited below:

A method to align an electrophotographic printing engines in a plurality of different print assemblies that are each capable of printing on a receiver to form one or more final prints to form an apparatus for digital printing including corrections for crosstrack misregistration comprising:

1[a] measuring each of the print assemblies to determine the location of a fixed component of the module relative to a receiver path in the x, y and z directions;

1[b] aligning two or more printing engines in an x and y direction by providing alignment features on the printing assemblies that align the assemblies in an x and y direction according to the measurements and that positioning the assemblies within a range of positions along the z direction; and

1[c] aligning a first printing engine to a second printing engine in a cross track direction (z direction) based on a cross track (z direction) position of the receiver as measured by the second engine and the measuring of the printing modules.

440. As one example of how the '255 Accused Products infringe at least claim 1, Ricoh Aficio SP C830DN meets the limitations of claim 1 of the '255 Patent for at least the reasons described below.

441. An image of Ricoh Aficio SP C830DN is provided below:

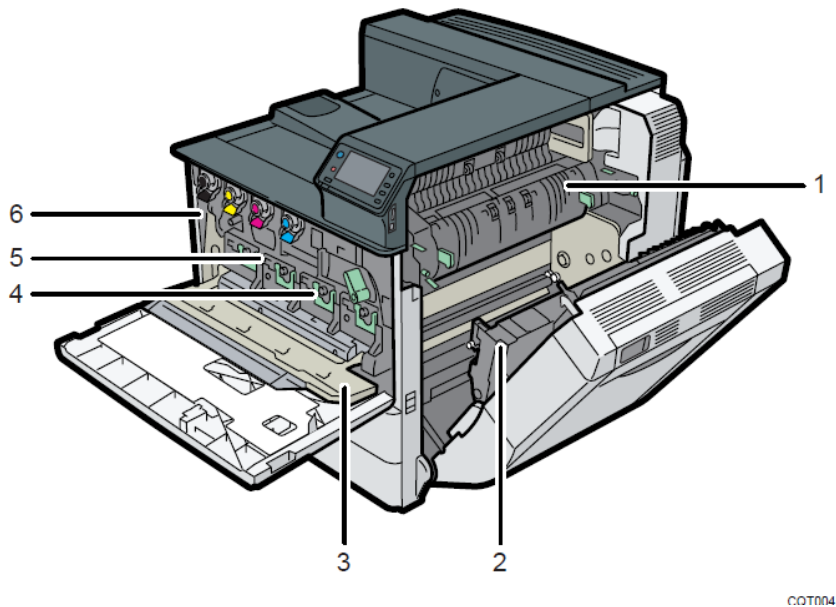

Ex. 54 (Ricoh Aficio SP C830DN-C831DN).

442. As a general matter and as described below, the limitations of claim 1 are satisfied for at least the following reasons. Ricoh Aficio SP C830DN includes print engines, where each engine could include those components needed to produce magenta, cyan, yellow, and black images. There are a plurality of different print assemblies including four Photoconductor Development Units (shown below as item 11 and abbreviated PCDU) for producing an image on a receiver such as a paper as shown below.

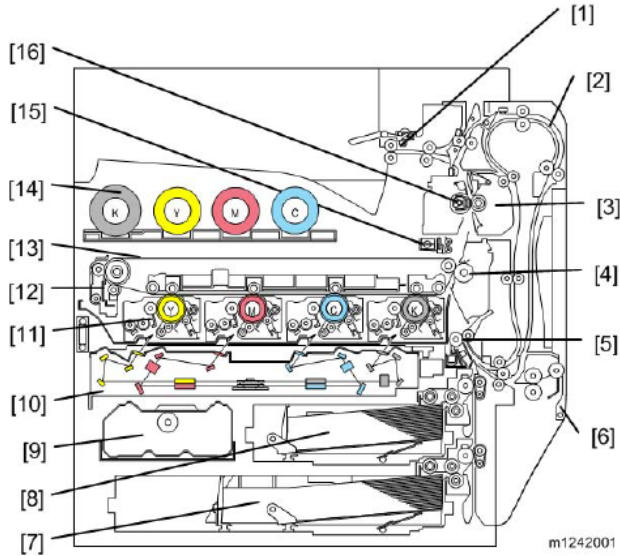

1. Paper exit rollers	9. Toner collection bottle
2. Duplex unit	10. Laser optics housing unit
3. Fusing unit	11. PCDU (4 colors)
4. Paper transfer roller	12. Image transfer belt cleaning unit
5. Registration roller	13. Image transfer belt unit
6. By-pass feed table	14. Toner bottle (4 colors)
7. Tray 2	15. ID sensor
8. Tray 1	16. Fusing sleeve belt unit

Ex. 54 (Ricoh Aficio SP C830DN-C831DN).

443. Ricoh Aficio SP C830DN also corrects for crosstrack misregistration by a employing a technique which utilizes at least a test pattern check and registrations of yellow (Y), magenta (M), cyan (C), and black (K) colors as shown below.

Test pattern check	Possible cause/Countermeasure
The main scan registrations of Y, M, C are shifted by more than ± 15 mm from the main scan registration of K.	<ul style="list-style-type: none"> Defective laser optics housing unit Defective BB <ol style="list-style-type: none"> Replace the laser optics housing unit. Replace the BB.
The sub scan registrations of Y, M, C are shifted by more than ± 20 mm from the sub scan registration of K.	<ul style="list-style-type: none"> Defective image transfer belt Defective drive units Defective BB <ol style="list-style-type: none"> Replace the image transfer belt. Replace the drum motor. Replace the BB.

Ex. 54 (Ricoh Aficio SP C830DN-C831DN).

444. Claim limitation 1[a] is satisfied for at least the following reasons. As shown below, Ricoh Aficio SP C830DN includes one print assembly such as an image transfer belt unit (item 13) and a second print assembly such as the 4 PCDUs (depicted below as item 11). Two print modes are available to the user: a color mode and a black-and-white mode. For a first print assembly of image transfer belt unit, the modes may be used to determine one of two locations of the image transfer belt: a “contact” location of the belt in contact with at least three of PCDUs when in a color mode and an “away” location of the belt away from the PCDUs when in the black-and-white mode. For a second print assembly, which houses a development clutch (depicted below as item 4), there is an “engagement” location for the color mode and a “disengagement” location for the black-and-white mode for three of the four PCDUs. A location of the fourth PCDU (containing black toner) may remain fixed, the location of which is independent of the mode. Relative to fourth PCDU, the image transfer belt (ITB) moves upward (in a z direction) as the paper travels in an x and y direction, and the development clutch may move downward (in a z direction); as such, the location of the fourth PCDU may be determined in the x, y, and z directions.

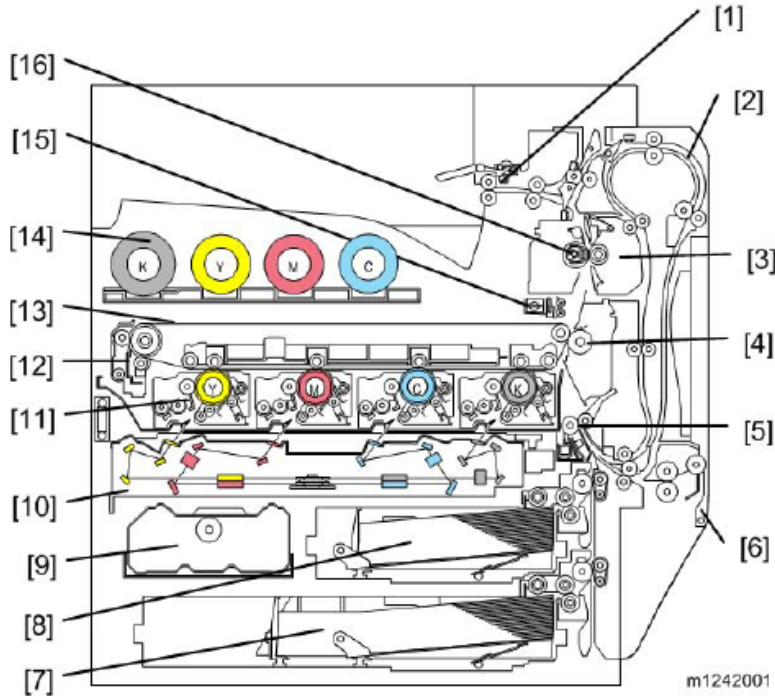

1. Paper exit rollers	9. Toner collection bottle
2. Duplex unit	10. Laser optics housing unit
3. Fusing unit	11. PCDU (4 colors)
4. Paper transfer roller	12. Image transfer belt cleaning unit
5. Registration roller	13. Image transfer belt unit
6. By-pass feed table	14. Toner bottle (4 colors)
7. Tray 2	15. ID sensor
8. Tray 1	16. Fusing sleeve belt unit

Ex.54 (Ricoh Aficio SP C830DN-C831DN).

445. Claim limitation 1[b] is satisfied for at least the following reasons. As shown below, Ricoh Aficio SP C830DN includes three print engines producing yellow (Y), magenta (M), and cyan (C) images and a fourth print engine producing a black (K) image which provide alignment features such as registrations. These registrations such as the “main scan” registrations and/or the “sub scan” registrations may be used in the alignment of Y, M, and C images with the K image in x and y directions.

Test pattern check	Possible cause/Countermeasure
The main scan registrations of Y, M, C are shifted by more than ± 15 mm from the main scan registration of K.	<ul style="list-style-type: none"> • Defective laser optics housing unit • Defective BB <ol style="list-style-type: none"> 1. Replace the laser optics housing unit. 2. Replace the BB.
The sub scan registrations of Y, M, C are shifted by more than ± 20 mm from the sub scan registration of K.	<ul style="list-style-type: none"> • Defective image transfer belt • Defective drive units • Defective BB <ol style="list-style-type: none"> 1. Replace the image transfer belt. 2. Replace the drum motor. 3. Replace the BB.

Ex. 54 (Ricoh Aficio SP C830DN-C831DN).

446. In addition, the presence of Y, M, and C registrations with a K registration indicates that both printing assemblies which includes the image transfer belt unit (shown as item 13) and the four PCDUs (shown as item 11), respectively, are aligned in x and y directions according to the “contact” and “engagement” measurements (discussed above). Furthermore, the presence of Y, M, and C registrations with a K registration indicates a location along a z direction that corresponds to the “contact” and “engagement” positions along the z direction of the image transfer belt and development clutches of the PCDUs, where the range of positions of the image transfer belt along the z direction extends between positions of “contact” and “away” positions, and the range of positions of the development clutches extends between positions of “engagement” and “disengagement” positions.

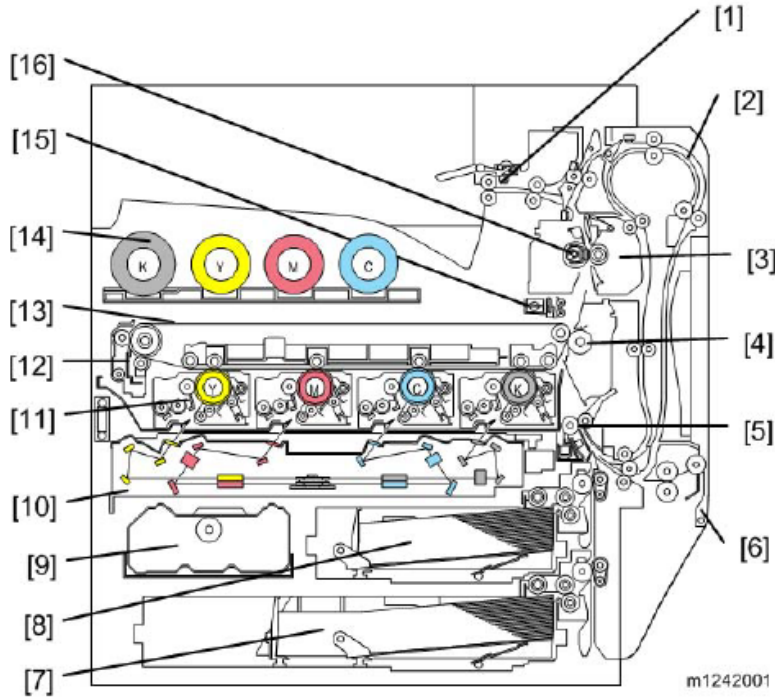

1. Paper exit rollers	9. Toner collection bottle
2. Duplex unit	10. Laser optics housing unit
3. Fusing unit	11. PCDU (4 colors)
4. Paper transfer roller	12. Image transfer belt cleaning unit
5. Registration roller	13. Image transfer belt unit
6. By-pass feed table	14. Toner bottle (4 colors)
7. Tray 2	15. ID sensor
8. Tray 1	16. Fusing sleeve belt unit

Ex. 54 (Ricoh Aficio SP C830DN-C831DN).

447. Claim limitation 1[c] is satisfied for at least the following reasons. As shown below, Ricoh Aficio SP C830DN includes first print engines which produce the yellow, magenta, and cyan registrations that may be aligned with a second print engine which produces the registration. These registrations encompass of cross track positions of the paper on which images are produced. Measurements of both the second engine (producing the black registration) and the printing modules (producing the yellow, magenta, and cyan registrations) are taken, and alignment of a first printing engine with a second printing engine is indicated

when the yellow, magenta, and cyan registrations have not shifted more than the black registration that is specified. As shown below, shifts up to +/- 15 mm (main scan) and +/- 20 mm (sub scan) as specified in the table indicate that an alignment exists between a first printing engine and a second printing engine.

Test pattern check	Possible cause/Countermeasure
The main scan registrations of Y, M, C are shifted by more than ± 15 mm from the main scan registration of K.	<ul style="list-style-type: none"> • Defective laser optics housing unit • Defective BB <ol style="list-style-type: none"> 1. Replace the laser optics housing unit. 2. Replace the BB.
The sub scan registrations of Y, M, C are shifted by more than ± 20 mm from the sub scan registration of K.	<ul style="list-style-type: none"> • Defective image transfer belt • Defective drive units • Defective BB <ol style="list-style-type: none"> 1. Replace the image transfer belt. 2. Replace the drum motor. 3. Replace the BB.

Ex. 54 (Ricoh Aficio SP C830DN-C831DN).

448. Ricoh also infringes under the doctrine of equivalents because it meets at least, and by way of example, the following claim limitation(s) of representative Claim 1 by performing substantially the same function as this limitation, performing this function in substantially the same way as this limitation, and achieving substantially the same results as claim limitation 1[a]. For example, and without limitation, Ricoh Aficio SP C830DN performs substantially the same function in substantially the same way and achieves substantially the same result at least because a fixed laser optic housing unit may be used when measuring each of the print assemblies to its location.

449. As a result of Defendant's unlawful activities, MASA has suffered and will continue to suffer irreparable harm for which there is no adequate remedy at law. Accordingly, MASA is entitled to preliminary and/or permanent injunctive relief.

450. Defendant's infringement of the '255 Patent has injured and continues to injure MASA in an amount to be proven at trial.

COUNT XVI

(Direct Infringement of the '795 Patent pursuant to 35 U.S.C. § 271(a))

451. MASA repeats, realleges, and incorporates by reference, as if fully set forth herein, the allegations of the preceding paragraphs, as set forth above.

452. Defendant has infringed and continues to infringe one or more claims of the '795 Patent, including at least claim 1, in violation of 35 U.S.C. § 271(a).

453. Defendant's infringement is based upon literal infringement or infringement under the doctrine of equivalents, or both.

454. Defendant's acts of making, using, importing, selling, and/or offering for sale infringing products and services have been without the permission, consent, authorization, or license of MASA.

455. Defendant's infringement includes the manufacture, use, sale, importation and/or offer for sale of Defendant's products and services, such as Ricoh Aficio SP C830DN, C831DN.

456. Claim 1 of the '795 Patent is recited below:

A printer comprising:

1[a] a marking mechanism for producing an image on media;

1[b] a tray for sheets of image receiver media;

1[c] a sheet feeding mechanism including a drive for advancing the sheets of image receiver media past the marking mechanism, said sheet feeding mechanism having a picker to remove the sheets of image receiver media from an aligned tray;

1[d] a media load position at which the tray is accessible to an operator for inserting a supply of the sheets of image receiver media;

1[e] a media pick position at which the tray is aligned with the picker;

1[f] a tray moving mechanism adapted to selectively move the tray between the media load position and the media pick position; and

1[g] a transmission (1) engageable to connect the drive of the sheet feeding mechanism to the tray moving mechanism, whereby the tray is moved between the pick position and the media load position by the drive and

1[h] (2) disengageable to enable advancement of the sheets of image receiver media without movement of the tray.

457. As one example of how the '795 Accused Products infringe at least claim 1, Ricoh Aficio MP 2555 meets the limitations of claim 1 of the '795 Patent for at least the reasons described below.

458. In general and as explained below, each of the limitations of claim are satisfied.

An image of Ricoh Aficio SP C830DN, which is a printer, is provided below:



459. Claim limitation 1[a] is satisfied for at least the following reasons. As shown below, Ricoh Aficio SP C830DN includes a marking mechanism for producing an image on media by using toner bottles, laser optics unit, image transfer belt, fusing unit for producing an image on media. The marking mechanism, for example, creates an image on a sheet of paper.

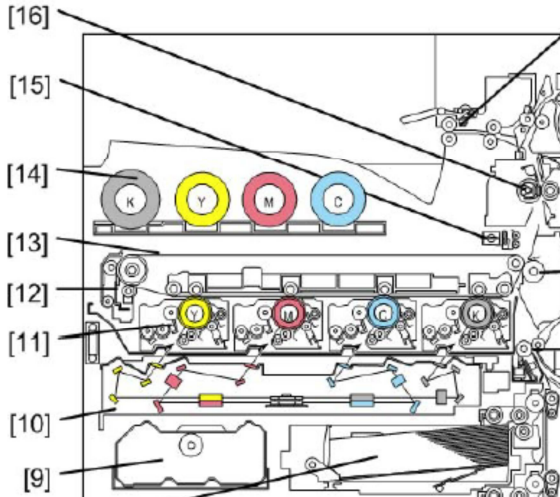

- 9. Toner collection bottle
- 10. Laser optics housing unit
- 11. PCDU (4 colors)
- 12. Image transfer belt cleaning unit
- 13. Image transfer belt unit
- 14. Toner bottle (4 colors)
- 15. ID sensor
- 16. Fusing sleeve belt unit

Ex. 54 (Ricoh_Aficio_SP_C830DN-C831DN).

460. Claim limitation 1[b] is satisfied for at least the following reasons. Ricoh Aficio SP C830DN includes a tray for sheets of image receiver media, as shown below in the interior and exterior images of trays 1 and 2 that hold sheets of paper (image receiver media).

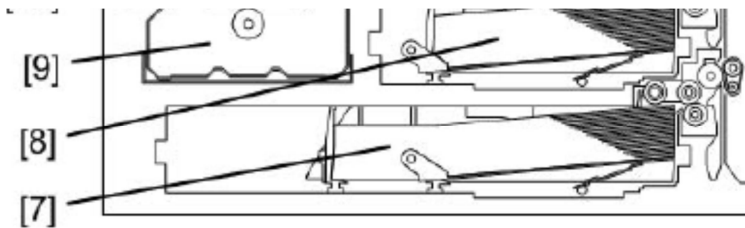

- 7. Tray 2
- 8. Tray 1

Ex. 54 (Ricoh_Aficio_SP_C830DN-C831DN).



Ex. 54 (Ricoh_Aficio_SP_C830DN-C831DN. Pdf, p. 42).

461. Claim limitation 1[c] is satisfied for at least the following reasons. As shown below, Ricoh Aficio SP C830DN includes paper trays having a drive, depicted below as paper feed motor [7] and feed clutch [8]) that pick and feed paper from the tray toward and past the printing mechanism.

Drive Layout

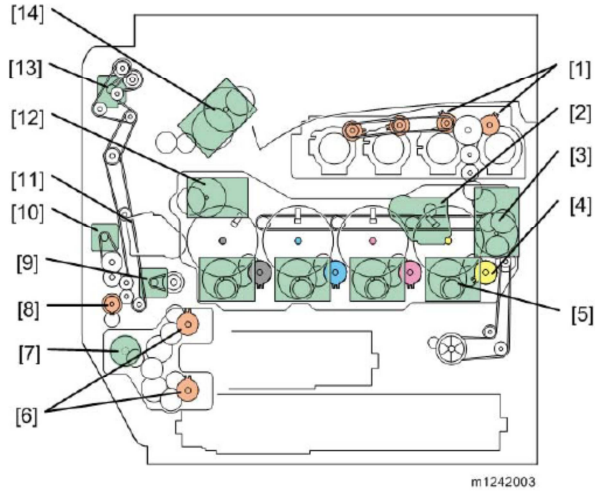

1. Toner supply clutch-K and -CMY:	Turns on/off the drive power to the toner supply unit (K and -CMY).
2. ITB (Image Transfer Belt) contact motor:	Moves the ITB into contact and away from the color PCDUs.
3. Toner transport motor:	Drives the toner attraction pumps and the toner collection coils from the PCDUs, from the transfer belt unit, and inside the toner collection bottle. Also rotates the toner bottles.
4. Development clutch (K, Y, M, C):	Turns on/off the drive power to the development unit (K, Y, M, C).
5. Drum/Development drive motor (K, Y, M, C):	Drives the color drum unit and development unit (K, Y, M, C).
6. Paper feed clutch:	Switches the drive power between tray 1 and tray 2.
7. Paper feed motor:	Drives the paper feed mechanisms (tray 1/tray 2).
8. By-pass feed clutch:	Turns on/off the drive power to the by-pass pick-up, feed and separation rollers.
9. Registration motor:	Drives the registration roller.
10. By-pass/duplex feed motor:	Drives the by-pass pick-up, feed and separation roller, and duplex transport rollers.
11. Paper transfer contact motor:	Moves the paper transfer roller in contact with the image transfer belt.
12. ITB drive motor:	Drives the image transfer belt unit.
13. Duplex inverter motor:	Drives the duplex inverter rollers and duplex transport rollers.
14. Fusing/paper exit motor:	Drives the fusing unit and paper exit section.

Ex. 54 (Ricoh_Aficio_SP_C830DN-C831DN).

462. Ricoh Aficio SP C830DN also includes a sheet feeding mechanism (Tray1 and Tray 2 feed [5], [6]) as shown below:

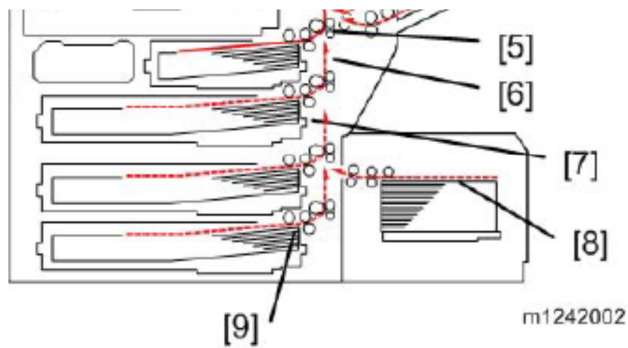

- 5. Tray 1 feed
- 6. Tray 2 feed
- 7. Tray 3: Optional paper feed unit/LCT
- 8. Tray 5: Optional LCT 1200
- 9. Tray 4: Optional paper feed unit

Ex. 54 (Ricoh_Aficio_SP_C830DN-C831DN. Pdf).

463. Claim limitation 1[d] is satisfied for at least the following reasons. As shown below, Ricoh Aficio SP C830DN includes a high capacity feeder (depicted below as tray 6) that can occupy a paper load position to facilitate operator paper loading.

Loading Paper

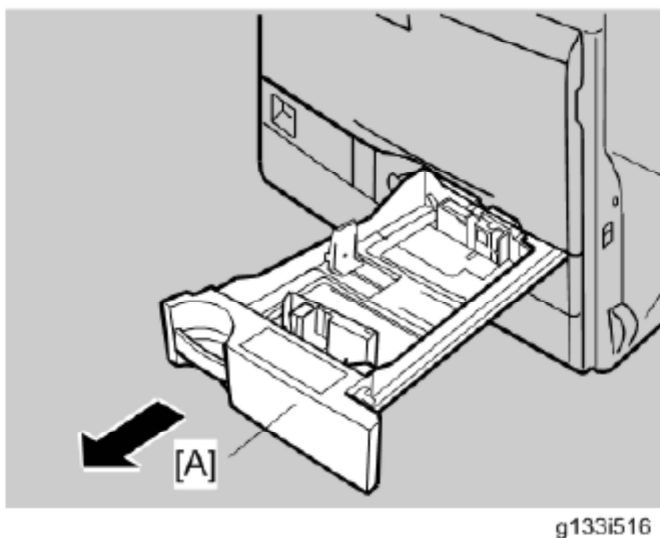

Ex 54 (Ricoh_Aficio_SP_C830DN-C831DN)

464. Claim limitation 1[e] is satisfied for at least the following reasons. As shown below, Ricoh Aficio SP C830DN includes a paper pick position (such as when lifted by the lift and feed motor), where the rollers can pick and feed paper from the tray. The paper feed unit shown below is used to pick up and feed paper from the tray:

Tray Lift Motor

1. Rear cover (🔧 p.118)
2. PSU bracket (🔧 p.250)
3. High voltage supply board bracket (🔧 p.254)

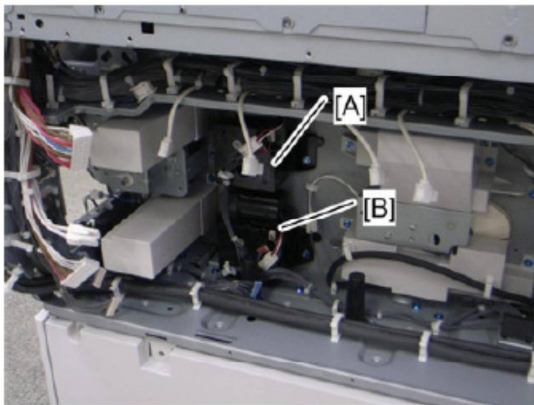

d027r173

4. Tray lift motor 1 [A] or 2 [B] (🔧 x 2, 📦 x 3, 📦 x 1 each)

Ex 54 (Rico_h_Aficio_SP_C830DN-C831DN).

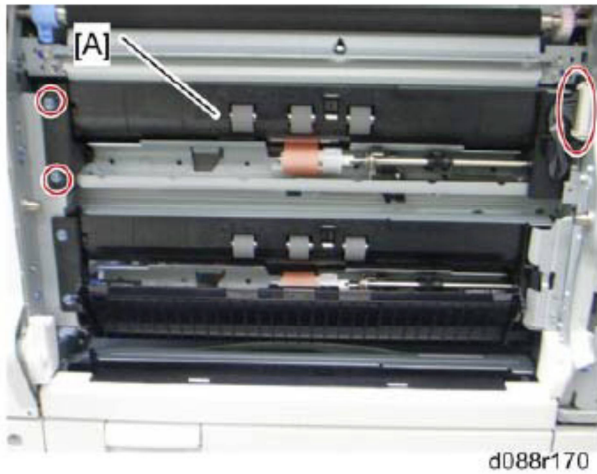



7. Paper feed unit [A] ( x 2,  x 1)

Pick-Up, Feed and Separation Rollers

Tray 1 and Tray 2

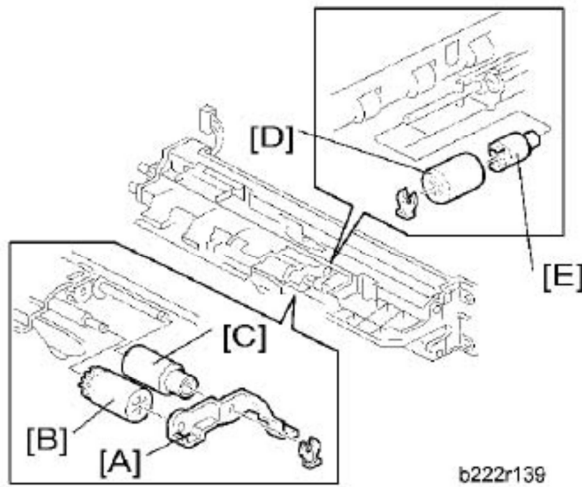
1. Paper feed unit ( p.222)



2. Roller holder [A] ( x 1)
3. Pick-up roller [B]
4. Feed roller [C]
5. Separation roller [D] and torque limiter [E] ( x 1)

Ex 54 (Ricoh_Aficio_SP_C830DN-C831DN).

465. Claim limitation 1[f] is satisfied for at least the following reasons. As shown below, Ricoh Aficio SP C830DN includes “Tray lift motor[s] 1 and 2” which are tray moving mechanisms to move a tray between the paper load position (which encompasses the open position in which an operator can load paper thereto, as well as the un-lifted position prior to feeding) and the paper feed position (the lifted position).

Drive Unit

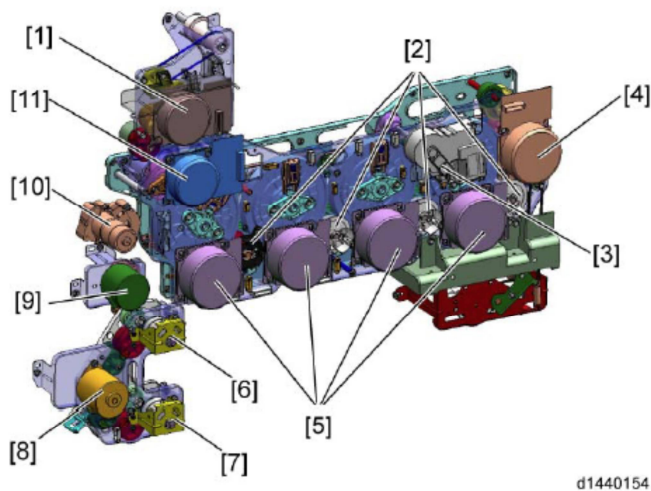

The drawing above shows the drive unit layout.

1. Fusing/paper exit motor	7. Paper feed clutch – Tray 2
2. Development clutches	8. Paper feed motor
3. Image transfer belt contact motor	9. Registration motor
4. Toner transport motor	10. Paper transfer contact motor
5. Drum/Development drive motors	11. ITB drive motor
6. Paper feed clutch – Tray 1	

There are some motors and clutches that are not shown in the above drawing:

• Tray lift motor 1 and 2	• Junction gate 1 motor
• Duplex inverter motor	• Shutter motor
• Duplex/By-pass Motor	• By-pass clutch

Ex. 54 (Ricoch_Aficio_SP_C830DN-C831DN).

466. Claim limitation 1[g] is satisfied for at least the following reasons. As shown below, Ricoh Aficio SP C830DN include a lift and feed motor of the Aficio Printers engaged (via transmission) so that the tray moves between the paper feed (lifted) position and the paper load (un-lifted) position.





7. Paper feed unit [A] ( x 2,  x 1)

Pick-Up, Feed and Separation Rollers

Tray 1 and Tray 2

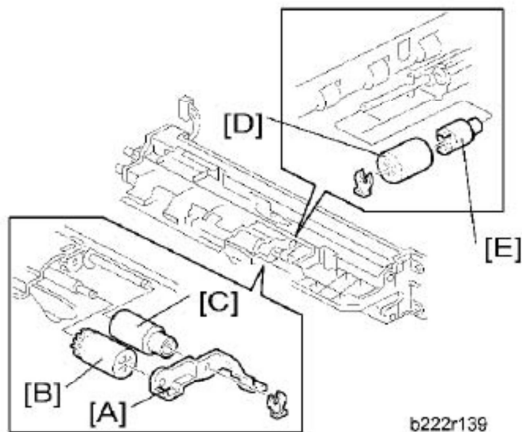
1. Paper feed unit ( p.222)



2. Roller holder [A] ( x 1)
3. Pick-up roller [B]
4. Feed roller [C]
5. Separation roller [D] and torque limiter [E] ( x 1)

Ex. 54 (Ricoh_Aficio_SP_C830DN-C831DN).

467. Claim limitation 1[h] is satisfied for at least the following reasons. As shown below, after the drive (lift and feed motor) of Ricoh Aficio SP C830DN lifts the paper tray, no further lifting of the tray occurs (i.e., the transmission is disengaged), and paper is fed by driving the rollers without movement of the tray. After transmission is disengaged, an image transfer belt [ITB 2] further enables advancement of the sheets of image receiver media.

Drive Layout

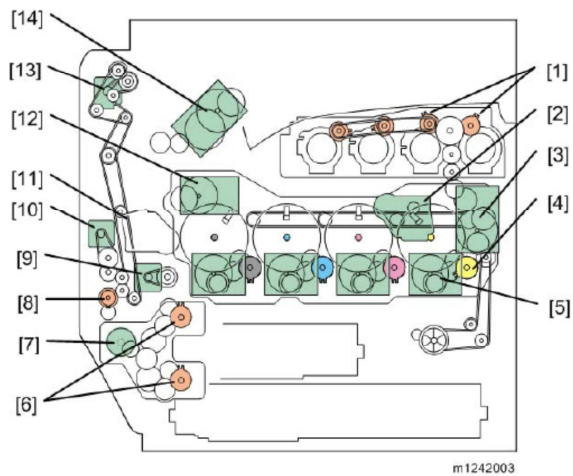

1. Toner supply clutch-K and -CMY:	Turns on/off the drive power to the toner supply unit (K and -CMY).
2. ITB (Image Transfer Belt) contact motor:	Moves the ITB into contact and away from the color PCUUs.
3. Toner transport motor:	Drives the toner attraction pumps and the toner collection coils from the PCUUs, from the transfer belt unit, and inside the toner collection bottle. Also rotates the toner bottles.
4. Development clutch (K, Y, M, C):	Turns on/off the drive power to the development unit (K, Y, M, C).
5. Drum/Development drive motor (K, Y, M, C):	Drives the color drum unit and development unit (K, Y, M, C).
6. Paper feed clutch:	Switches the drive power between tray 1 and tray 2.
7. Paper feed motor:	Drives the paper feed mechanisms (tray 1/tray 2).

8. By-pass feed clutch:	Turns on/off the drive power to the by-pass pick-up, feed and separation rollers.
9. Registration motor:	Drives the registration roller.
10. By-pass/duplex feed motor:	Drives the by-pass pick-up, feed and separation roller, and duplex transport rollers.
11. Paper transfer contact motor:	Moves the paper transfer roller in contact with the image transfer belt.
12. ITB drive motor:	Drives the image transfer belt unit.
13. Duplex inverter motor:	Drives the duplex inverter rollers and duplex transport rollers.
14. Fusing/paper exit motor:	Drives the fusing unit and paper exit section.

Ex. 54 (Ricoh_Aficio_SP_C830DN-C831DN).

468. Ricoh also infringes under the doctrine of equivalents because it meets at least, and by way of example, the following claim limitation (s) of representative Claim 1 by performing substantially the same function as this limitation, performing this function in substantially the same way as this limitation, and achieving substantially the same results as claim limitation 1[g] and/or 1[h]. For example, and without limitation, Ricoh Aficio SP C830DN performs substantially the same function in substantially the same way and achieves substantially the same result at least because it changes the spacing between the paper trays and the picker so that the picker can remove a sheet of paper from the paper supply in the same way and to achieve the same result at the recited claim.

469. As a result of Defendant's unlawful activities, MASA has suffered and will continue to suffer irreparable harm for which there is no adequate remedy at law. Accordingly, MASA is entitled to preliminary and/or permanent injunctive relief.

470. Defendant's infringement of the '795 Patent has injured and continues to injure MASA in an amount to be proven at trial.

COUNT XVII

(Direct Infringement of the '089 Patent pursuant to 35 U.S.C. § 271(a))

471. MASA repeats, realleges, and incorporates by reference, as if fully set forth herein, the allegations of the preceding paragraphs, as set forth above.

472. Defendant has infringed and continues to infringe one or more claims of the '089 Patent, including at least claim 1, in violation of 35 U.S.C. § 271(a).

473. Defendant's infringement is based upon literal infringement or infringement under the doctrine of equivalents, or both.

474. Defendant's acts of making, using, importing, selling, and/or offering for sale infringing products and services have been without the permission, consent, authorization, or license of MASA.

475. Defendant's infringement includes the manufacture, use, sale, importation and/or offer for sale of Defendant's products and services, such as Ricoh Aficio SP C830DN, C831DN.

476. Claim 1 of the '089 Patent is recited below:

A method of printing using an electrophotographic print engine including a single development module that can develop a single toner on a primary imaging member of the single development module and a multi-development module that can develop either one of two toners on a primary imaging member of the multi-development module, the method comprising:

1[a] determining a combination of toners required to form an image according to a job specification;

1[b] determining that the combination of toners includes two toners in the multi-development module, developing and transferring first toner separations onto a receiver including a first one of the two toners in a development station of the multi-development module;

1[c] passing the receiver through the print engine a second time;

1[d] developing and transferring a color separation using the other of the two toners in the multi-development module onto the first toner separations; and

1[e] determining that the identified combination of toners does not include two toners in two development stations in the multi-development module, forming and transferring a first combination of the identified toner separations onto the receiver and diverting the receiver to at least one of an inverter and an exit.

477. As one example of how the '089 Accused Products infringe at least claim 1, Ricoh Aficio SP C830DN meets the limitations of claim 1 of the '089 Patent for at least the reasons described below.

478. As a general matter and as explained below, the limitations of claim 1 are satisfied because Ricoh Aficio SP C830DN is a laser printer that uses an electrophotographic print engine that includes a development module that can develop a single toner for Black and White printing and a development module that can develop more than one toners on an imaging member, such as a drum, in the development module.

479. As shown below, Ricoh Aficio SP C830DN are laser printers with an electrophotographic print engine performing laser beam scanning and electrophotographic printing using four drums. The printers can develop a single Black toner to print in Black and White or develop one of two color toners to print in full color.

Print Process:	Laser beam scanning and electro-photographic printing 4 drums tandem method
Resolution:	Print: 200dpi / 300dpi / 400dpi / 600dpi / 1200dpi
Gradation:	Print: 200dpi, 300dpi, 400dpi, 1200dpi : 1 bit / pixel 600dpi : 4bit / pixel 600dpi : 2bit / pixel 600dpi : 1 bit / pixel
First print (normal mode):	P3c: Color: 5.7 seconds or less (A4/LT LEF) Black & white: 3.7 seconds or less (A4/LT LEF) P3d: Color: 5.1 seconds or less (A4/LT LEF) Black & white: 3.4 seconds or less (A4/LT LEF)

Ex. 54 (Ricoh_Aficio_SP_C830DN-C831DN.pdf at p. 633).

480. As shown below, Ricoh Aficio SP C830DN includes electrophotographic components including laser optics, image transfer belts, toners, and a fusing unit. The printers include four toners (14), each toner corresponding to Black (K), Yellow (Y), Magenta (M), and Cyan (C) colors respectively.

Component Layout

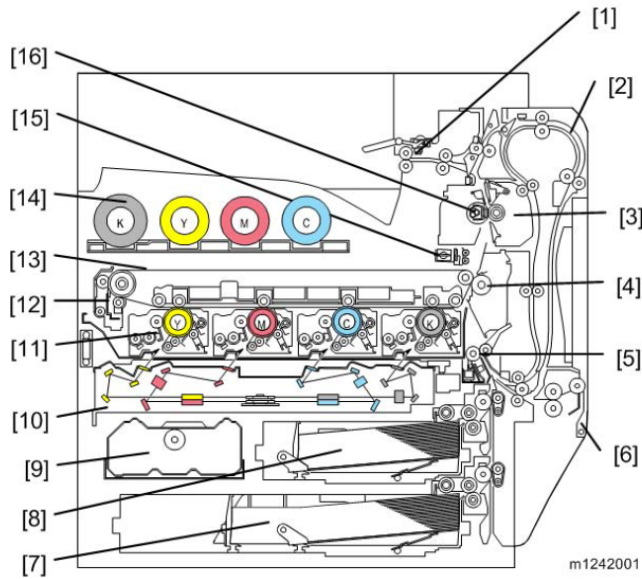

1. Paper exit rollers	9. Toner collection bottle
2. Duplex unit	10. Laser optics housing unit
3. Fusing unit	11. PCDU (4 colors)
4. Paper transfer roller	12. Image transfer belt cleaning unit
5. Registration roller	13. Image transfer belt unit
6. By-pass feed table	14. Toner bottle (4 colors)
7. Tray 2	15. ID sensor
8. Tray 1	16. Fusing sleeve belt unit

Component Layout

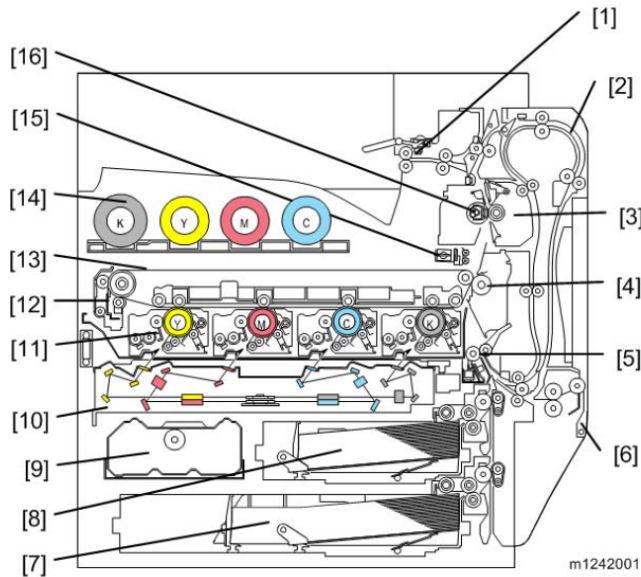

1. Paper exit rollers	9. Toner collection bottle
2. Duplex unit	10. Laser optics housing unit
3. Fusing unit	11. PCDU (4 colors)
4. Paper transfer roller	12. Image transfer belt cleaning unit
5. Registration roller	13. Image transfer belt unit
6. By-pass feed table	14. Toner bottle (4 colors)
7. Tray 2	15. ID sensor
8. Tray 1	16. Fusing sleeve belt unit

Ex. 54 (Ricoh_Aficio_SP_C830DN-C831DN.pdf at p. 22).

481. Shown below is an overview of the drive layout for the electrophotographic printing process. The drive layout shows a toner clutch connected to a toner supply unit that supplies toner to a respective imaging member, such as a photoconductor drum unit (PCDU) and the development unit. The printing process develops a toner image on the PCDU and transfers the toner image onto paper via a transfer belt. For Black and White printing, the Ricoh Aficio SP C830DN develops a single toner, Black, on the PCDU primary imaging member of the development module. For color printing, Ricoh Aficio SP C830DN sequentially develop one of two or more toners in the development module.

Drive Layout

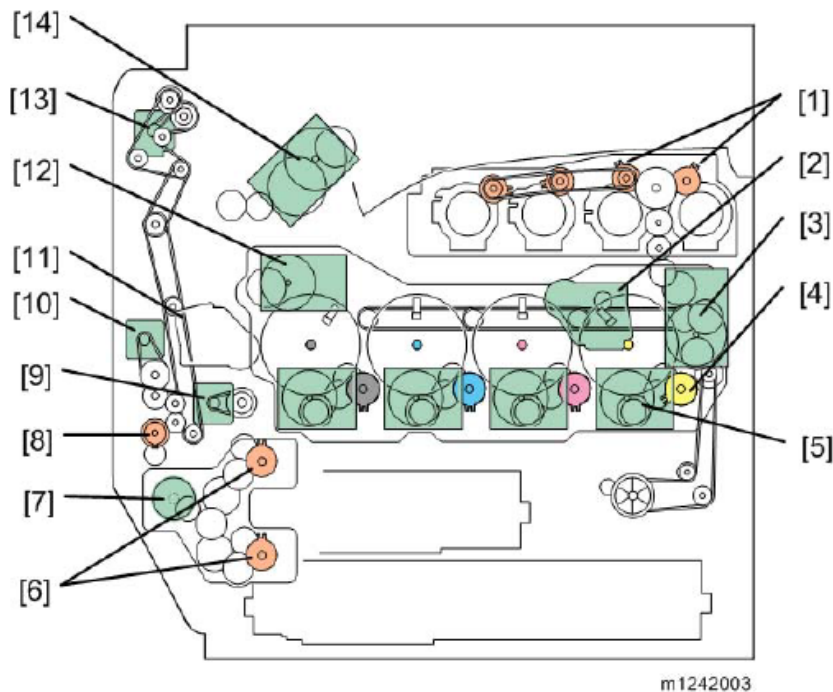

1. Toner supply clutch-K and -CMY:	Turns on/off the drive power to the toner supply unit (K and -CMY).
2. ITB (Image Transfer Belt) contact motor:	Moves the ITB into contact and away from the color PCUs.
3. Toner transport motor:	Drives the toner attraction pumps and the toner collection coils from the PCUs, from the transfer belt unit, and inside the toner collection bottle. Also rotates the toner bottles.
4. Development clutch (K, Y, M, C):	Turns on/off the drive power to the development unit (K, Y, M, C).
5. Drum/Development drive motor (K, Y, M, C):	Drives the color drum unit and development unit (K, Y, M, C).
6. Paper feed clutch:	Switches the drive power between tray 1 and tray 2.
7. Paper feed motor:	Drives the paper feed mechanisms (tray 1/tray 2).

Ex. 54 (Ricoh_Aficio_SP_C830DN-C831DN.pdf at p. 24).

482. An exemplary drum unit and the development unit for the Yellow toner is shown below. Each toner color is associated with a respective drum unit and development unit – for example there is one for Yellow shown below but separate units for other colors, such as Black.

As such, Ricoh Aficio SP C830DN develops either one of two toners on a primary imaging member of the multi-development module.

Drum Unit and Development Unit

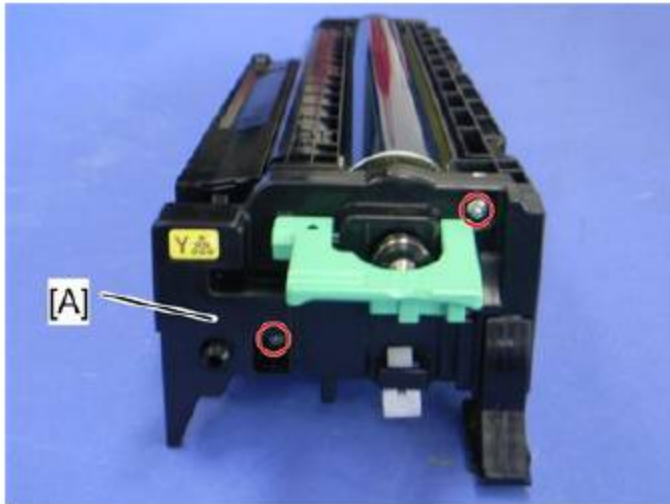

d027r120

Ex. 54 (Ricoch_Aficio_SP_C830DN-C831DN.pdf at p. 140).

483. Claim limitation 1[a] is satisfied for at least the following reasons. Ricoh Aficio SP C830DN uses a combination of one or more toners for forming toner images on drum surfaces before transferring the toner images to paper as per incoming image data for a job.

484. As shown below, Ricoh Aficio SP C830DN use a combination of the four toners, black (K), yellow (Y), magenta (M), and cyan (C) to print images.

This section describes how to use the screen on the control panel.

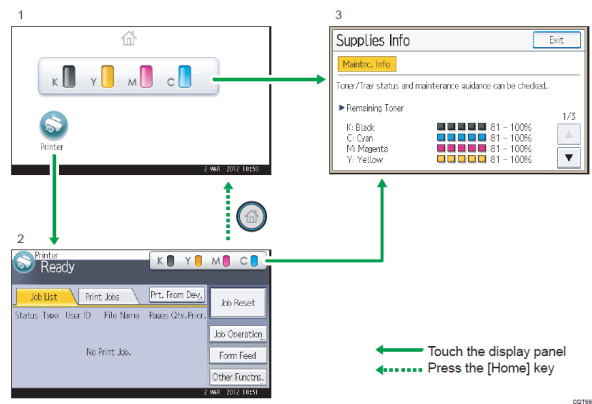

1. [Home] screen

Displays function and shortcut icons. For details, see p.16 "How to Use the [Home] Screen".

2. [Printer] screen

Displays operation status, messages, and function menus. For details, see p.18 "How to Use the Screens on the Control Panel".

3. [Supplies Info] screen

Allows you to check the printer status, such as toner, paper, and waste toner levels.

Ex. 56 (aficio_sp_c830dn.pdf at p. 20).

485. As shown below, the printers receive print job specifications from a computer running an operating system such as Windows or Mac OS X therefore determine the combination of toners required to form an image according to the image data for the job specification.

Printing with Windows (PCL 5c/5e)

★ Important

- The default setting is duplex printing. If you want to print on only one side, select [Off] for the duplex setting.
- If you send a print job via USB 2.0 while the printer is in Low Power mode or Sleep mode, an error message might appear when the print job is complete. In this case, check if the document was printed.

1. After creating a document, open the [Printing Preferences] dialog box in the document's native application.

For details about displaying the [Printing Preferences] dialog box, see p.30 "Displaying the Printing Preferences dialog box in an application".

Ex. 56 (aficio_sp_c830dn.pdf at p. 62).

Printing with Mac OS X

Follow the procedure below to print using the PostScript 3 printer driver for Mac OS X.

1. **After creating a document, open the printing preferences screen in the document's native application.**

For details about displaying the printing preferences screen, see p.32 "Displaying the printing preferences screen from an application"

2. **In the " Paper Size:" menu, select the size of the document to be printed.**

3. **In the "Orientation:" menu, select the orientation of the document.**

4. **Select [Paper Feed] in the pop-up menu.**

5. **Select the paper tray that contains the paper to which you want to print.**

If you select [Auto Select], the paper tray is automatically selected according to the paper size and type specified.

6. **Select [Printer Features] in the pop-up menu.**

7. **In the "Feature Sets:" menu, select the appropriate set of features to display the "Paper Type:" menu.**

8. **In the "Paper Type:" menu, select the type of paper that is loaded in the paper tray.**

9. **In the "Feature Sets:" menu, select the appropriate set of features to display the "Color Mode:" menu.**

10. **In the "Color Mode:" menu, select the color mode for the print job.**

Select [Color] for color printing.

Select [Black and White] for black and white printing.

Ex. 56 (aficio_sp_c830dn.pdf at p. 63).

486. Claim limitation 1[b] is satisfied for at least the following reasons. Ricoh Aficio SP C830DN determines the combination of toners required for completing a job specification, wherein the combination of toners selected may include a combination of any two toners, such as Cyan and Magenta, in the development module. Ricoh Aficio SP C830DN develops and transfers the toner separations for the determined combination of two toners onto a receiver, such as an image transfer belt, in a development station of the development module.

487. As shown below, Ricoh Aficio SP C830DN perform Black and White or full color printing depending upon the job specifications. The printers accordingly select a combination of toners that may comprise two toners, for printing the desired images.

7. Select [Color] or [Black and White] in the "Color/ Black and White:" list.

Select [Color] for color printing.

Select [Black and White] for black-and-white printing.

Ex. 56 (aficio_sp_c830dn.pdf at p. 61).

488. As shown below, Ricoh Aficio SP C830DN includes four toner bottles (K, Y, M, and C), a photoconductor drum unit (PCDU) (11), an image transfer belt unit (13), laser optics housing unit (10) and a fusing unit (3). The laser optics unit forms electrostatic charge distributions on the photoconductor drums, which electrostatically attract positive toner particles to form latent toner images on the photoconductor drums. The latent toner images are then transferred to the image transfer belt unit 13 receiver that is maintained at a greater negative potential than the photoconductor drum surfaces. The image transfer belt 13 transfers the toner images onto the paper which are then fused into the paper in the fusing unit. As such, Ricoh Aficio SP C830DN develops and transfers first toner images onto the image transfer belt 13 and subsequently onto the paper. The first toner separation images may comprise a first one of the two toners from a toner development station of the multi-development module depending upon the print job specifications.

Component Layout

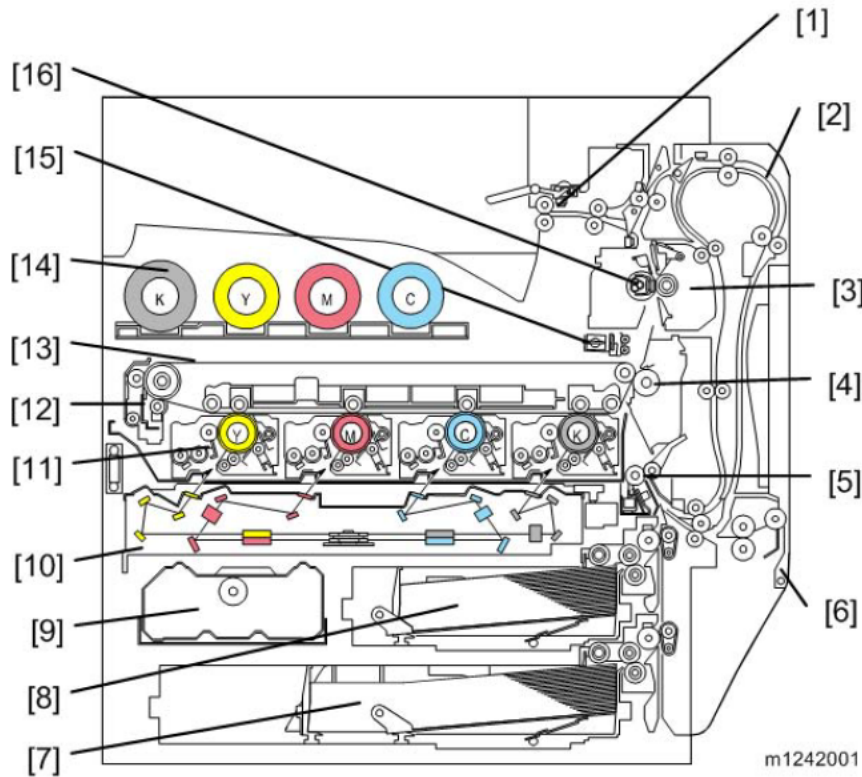

1. Paper exit rollers	9. Toner collection bottle
2. Duplex unit	10. Laser optics housing unit
3. Fusing unit	11. PCDU (4 colors)
4. Paper transfer roller	12. Image transfer belt cleaning unit
5. Registration roller	13. Image transfer belt unit
6. By-pass feed table	14. Toner bottle (4 colors)
7. Tray 2	15. ID sensor
8. Tray 1	16. Fusing sleeve belt unit

Ex. 54 (Ricoh_Aficio_SP_C830DN-C831DN.pdf at p. 22).

489. By way of further illustration, shown below is an overview of the drive layout for the electrophotographic printing process. The drive layout shows a toner clutch connected to a toner supply unit that supplies toner to a respective photoconductor drum unit (PCDU) and development unit. The printing process develops a toner image on the PCPU and transfers the toner image onto paper via an intermediary receiver comprising the image transfer belt. As

such, Ricoh Aficio SP C830DN develops and transfers first toner separation images onto the image transfer belt receiver and then subsequently transfer the first toner separation images onto the paper. The first toner images may include a first one of the two toners in a development station of the multi-development module depending upon the print job specifications.

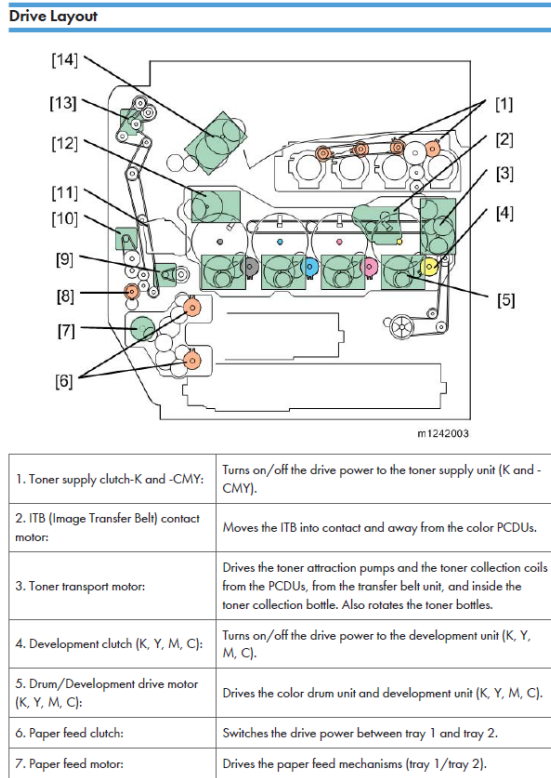

Ex. 54 (Ricoch_Aficio_SP_C830DN-C831DN.pdf at p. 24).

490. As described above, each toner color is associated with a respective PCDU.

Drum Unit and Development Unit

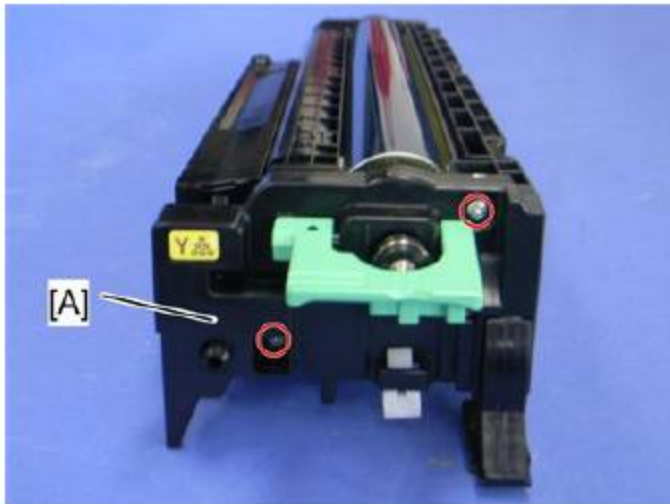

d027r120

Ex. 54 (Ricoh_Aficio_SP_C830DN-C831DN.pdf at p. 140).

491. Claim limitation 1[c] is satisfied for at least the following reasons. As shown below, Ricoh Aficio SP C830DN includes a duplex gate for directing the paper into the print engine a second time and a duplex unit for moving the paper through the print engine the second time.

Component Layout

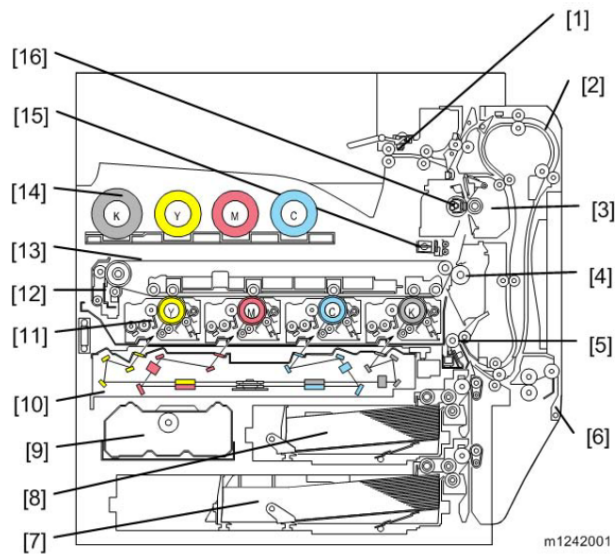

1. Paper exit rollers	9. Toner collection bottle
2. Duplex unit	10. Laser optics housing unit
3. Fusing unit	11. PCDU (4 colors)
4. Paper transfer roller	12. Image transfer belt cleaning unit
5. Registration roller	13. Image transfer belt unit
6. By-pass feed table	14. Toner bottle (4 colors)
7. Tray 2	15. ID sensor
8. Tray 1	16. Fusing sleeve belt unit

Ex. 54 (Ricoh_Aficio_SP_C830DN-C831DN.pdf at p. 22).

492. As another example, shown below are paths the paper may take through Ricoh Aficio SP C830DN. For duplex printing, the paper is guided through the print engine a second time via a duplex inverter (2) and a duplex feed (3).

Paper Path

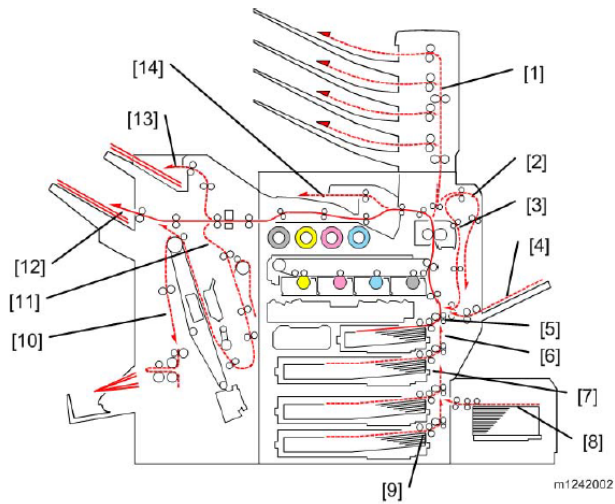

1. Mail bin	8. Tray 5: Optional LCT 1200
2. Duplex inverter	9. Tray 4: Optional paper feed unit
3. Duplex feed	10. Finisher booklet stapler (Optional)
4. By-pass tray feed	11. Finisher stapler (Optional)
5. Tray 1 feed	12. Finisher upper tray (Optional)
6. Tray 2 feed	13. Finisher proof tray (Optional)
7. Tray 3: Optional paper feed unit/LCT	14. Output tray

Ex. 54 (Ricoh_Aficio_SP_C830DN-C831DN.pdf at p. 23).

493. Claim limitation 1[d] is satisfied for at least the following reasons. As shown below, Ricoh Aficio SP C830DN develops and transfers a toner image onto the first toner separations, using the other of the two toners in the multi-development module. As shown below, Ricoh Aficio SP C830DN develops a toner image, comprising a combination of the toners K, Y, M, and C, on the corresponding toner drum unit and transfers the toner image onto the image transfer belt 13. By consecutively building up the toner images on the transfer belt, based on selecting a combination of the toners K, Y, M, and C, Ricoh Aficio SP C830DN overlays color separation images onto the image transfer belt 13 that are eventually transferred onto paper.

Component Layout

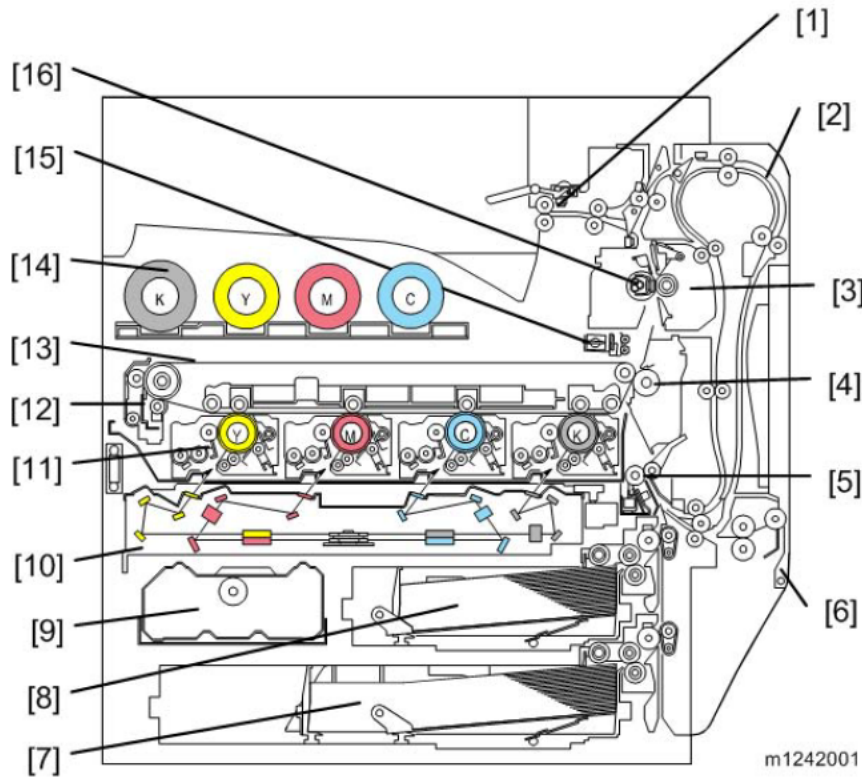

1. Paper exit rollers	9. Toner collection bottle
2. Duplex unit	10. Laser optics housing unit
3. Fusing unit	11. PCDU (4 colors)
4. Paper transfer roller	12. Image transfer belt cleaning unit
5. Registration roller	13. Image transfer belt unit
6. By-pass feed table	14. Toner bottle (4 colors)
7. Tray 2	15. ID sensor
8. Tray 1	16. Fusing sleeve belt unit

Ex. 54 (Ricoh_Aficio_SP_C830DN-C831DN.pdf at p. 22).

494. Claim limitation 1[e] is satisfied for at least the following reasons. As shown below, Ricoh Aficio SP C830DN selects two toners from the four available toners for forming and transferring a combination of the selected two toner images onto the image transfer belt and then onto the paper. A combination of the selected two toners need not include the remaining

two toners of the multi-development module depending upon the job specification. Ricoh Aficio SP C830DN then diverts the paper comprising the first combination of the identified toner separations to at least one of an inverter, such as a duplex gate, and an exit.

495. As shown below, Ricoh Aficio SP C830DN selects toners for forming and transferring toner images onto an image transfer belt (13) that are then transferred and fused onto a paper receiver in the fusing unit (3). The paper is then transported towards at least one of the duplex unit (2) that functions as an inverter, and the paper exit rollers (1).

Component Layout

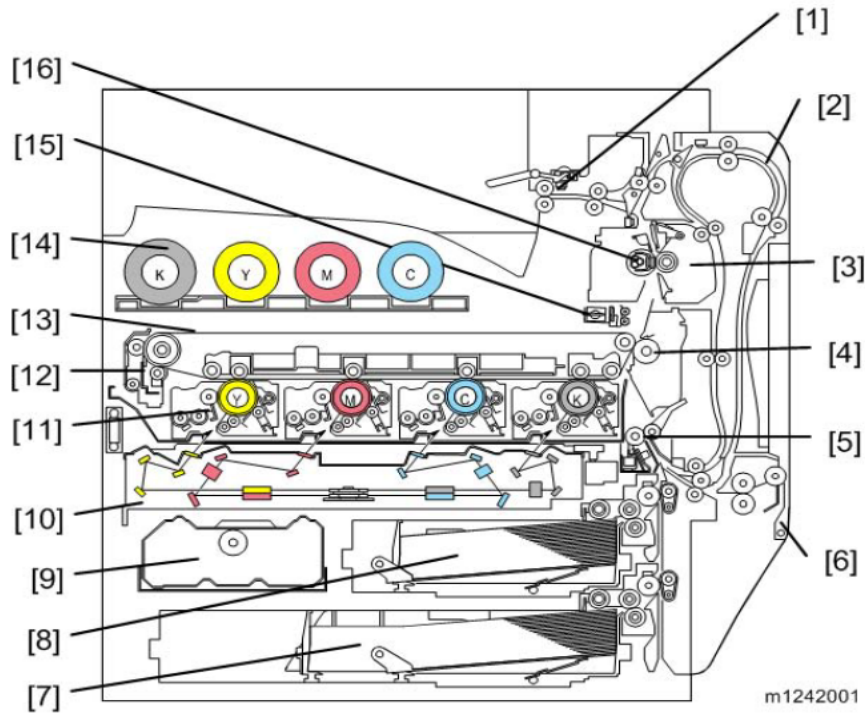

1. Paper exit rollers	9. Toner collection bottle
2. Duplex unit	10. Laser optics housing unit
3. Fusing unit	11. PCDU (4 colors)
4. Paper transfer roller	12. Image transfer belt cleaning unit
5. Registration roller	13. Image transfer belt unit
6. By-pass feed table	14. Toner bottle (4 colors)
7. Tray 2	15. ID sensor
8. Tray 1	16. Fusing sleeve belt unit

Ex. 54 (Ricoh_Aficio_SP_C830DN-C831DN.pdf at p. 22).

496. Ricoh also infringes under the doctrine of equivalents because it meets at least, and by way of example, the following claim limitation (s) of representative Claim 1 by performing substantially the same function as this limitation, performing this function in substantially the same way as this limitation, and achieving substantially the same results as claim limitation 1[e]. For example, and without limitation, Ricoh Aficio SP C830DN performs substantially the same function in substantially the same way and achieves substantially the same result at least because they determine a combination of toners that may include two out of four toners in the development stations, form and transfer a first combination of the two toner separations onto paper and divert the paper to either an inverter for duplex printing or to an exit.

497. As a result of Defendant's unlawful activities, MASA has suffered and will continue to suffer irreparable harm for which there is no adequate remedy at law. Accordingly, MASA is entitled to preliminary and/or permanent injunctive relief.

498. Defendant's infringement of the '089 Patent has injured and continues to injure MASA in an amount to be proven at trial.

COUNT XVIII

(Direct Infringement of the '022 Patent pursuant to 35 U.S.C. § 271(a))

499. MASA repeats, realleges, and incorporates by reference, as if fully set forth herein, the allegations of the preceding paragraphs, as set forth above.

500. Defendant has infringed and continues to infringe one or more claims of the '022 Patent, including at least claim 1, in violation of 35 U.S.C. § 271(a).

501. Defendant's infringement is based upon literal infringement or infringement under the doctrine of equivalents, or both.

502. Defendant's acts of making, using, importing, selling, and/or offering for sale infringing products and services have been without the permission, consent, authorization, or license of MASA.

503. Defendant's infringement includes the manufacture, use, sale, importation and/or offer for sale of Defendant's products and services, such as Ricoh Aficio SP C830DN, C831DN.

504. Claim 1 of the '022 Patent is recited below:

A printing apparatus comprising:

1[a] a base to support the printing apparatus during operation;

1[b] a wall extending at an angle from the base;

1[c] a print region;

1[d] a media input holder;

1[e] a media advance system for advancing media from the media input holder to the print region for printing on a first side of a sheet of media; and

1[f] a pivotable duplexing unit comprising a duplexing media path for reversing the sheet of media in order to print on a second side of a sheet opposite the first side,

1[g] wherein the pivotable duplexing unit is attached to the wall using a hinge having an axis that is substantially perpendicular to the base, and

1[h] wherein the wall includes a support member of the hinge and the pivotable duplexing unit includes a pin member of the hinge for pivoting relative to the support member of the hinge.

505. As one example of how the '3005 Accused Products infringe at least claim 1, Ricoh Aficio SP C830DN meets the limitations of claim 1 of the '3005 Patent for at least the reasons described below.

506. An image of Ricoh Aficio SP C830DN is provided below:



m1242026

Ex. 57 (C830 DN Field Service Manual).

507. As a general matter, the limitations of claim 1 are satisfied because Ricoh Aficio SP C830DN is a printing apparatus as discussed below.

508. Claim limitation 1[a] is satisfied for at least the following reasons. As shown below, Ricoh Aficio SP C830DN includes a base support that houses two paper trays and that supports the printing apparatus.



m1242026

Ex. 57 (C830 DN Field Service Manual).

509. Claim limitation 1[b] is satisfied for at least the following reasons. As shown below, Ricoh Aficio SP C830DN includes a wall having a by-pass feed table and the wall extends upward and away from the base at an angle as shown below.

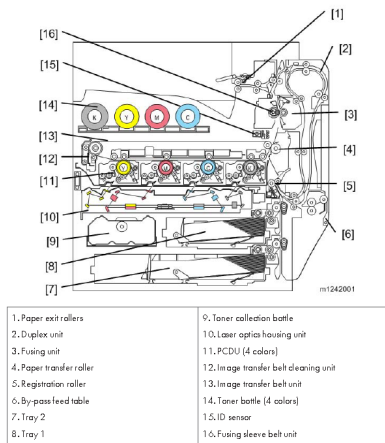

Ex. 57 (C830 DN Field Service Manual).

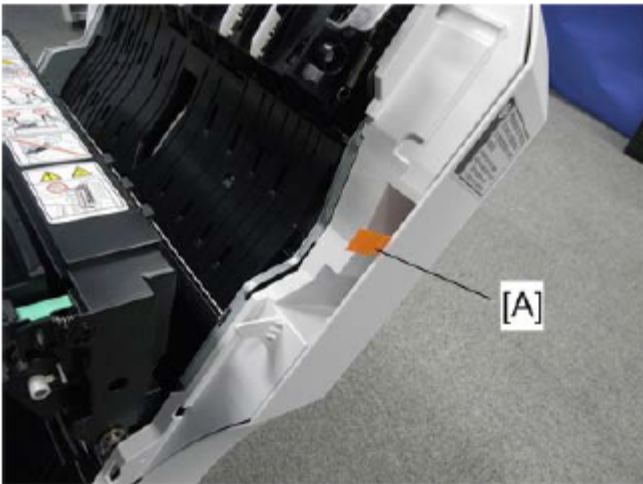

m1242021

Ex. 57 (C830 DN Field Service Manual).

510. Claim limitation 1[c] is satisfied for at least the following reasons. As shown below, Ricoh Aficio SP C830DN includes a print region which includes the fusing unit (item 3), the registration roller (item 5), and the region in between them.

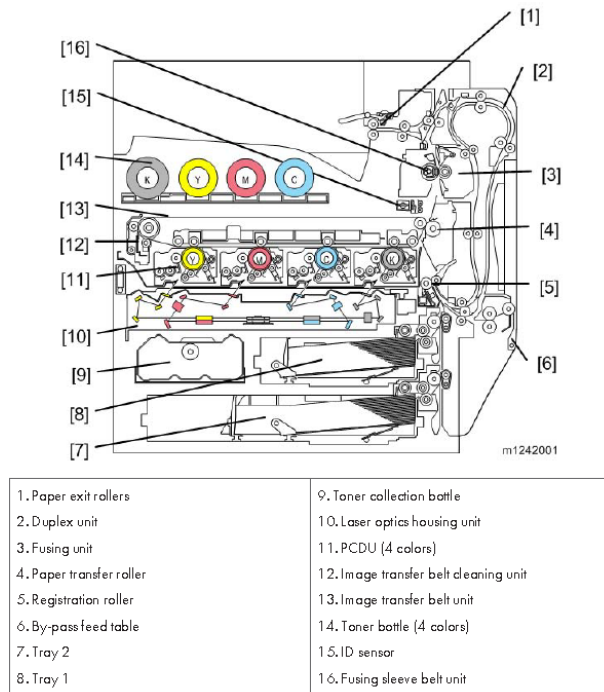

Ex. 57 (C830 DN Field Service Manual).

511. Claim limitation 1[d] is satisfied for at least the following reasons. As shown below, Ricoh Aficio SP C830DN includes a media input holder (e.g., to hold paper) comprised of tray 1.

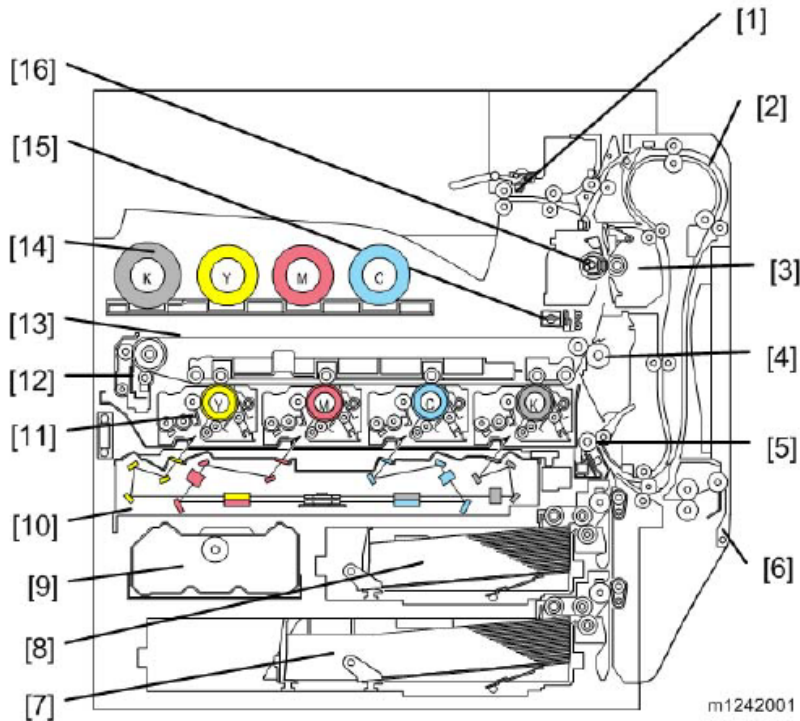

1. Paper exit rollers	9. Toner collection bottle
2. Duplex unit	10. Laser optics housing unit
3. Fusing unit	11. PCDU (4 colors)
4. Paper transfer roller	12. Image transfer belt cleaning unit
5. Registration roller	13. Image transfer belt unit
6. By-pass feed table	14. Toner bottle (4 colors)
7. Tray 2	15. ID sensor
8. Tray 1	16. Fusing sleeve belt unit

Ex. 57 (C830 DN Field Service Manual).

512. Claim limitation 1[e] is satisfied for at least the following reasons. As shown below, Ricoh Aficio SP C830DN has a media advance system that includes a paper feed motor (item 7) and a registration motor (item 9) to advance the paper from tray 1 to a registration roller and into the print region (discussed above as the fusing unit, the registration roller, and the region in between them), wherein a first side of the paper is printed upon.

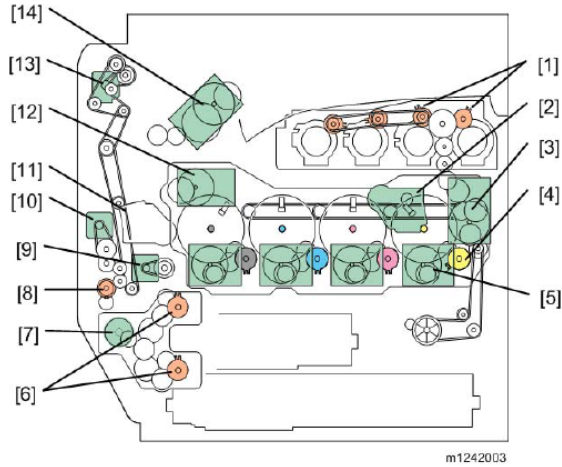

1. Toner supply clutch-K and -CMY:	Turns on/off the drive power to the toner supply unit (K and -CMY).
2. ITB (Image Transfer Belt) contact motor:	Moves the ITB into contact and away from the color PCUs.
3. Toner transport motor:	Drives the toner attraction pumps and the toner collection coils from the PCUs, from the transfer belt unit, and inside the toner collection bottle. Also rotates the toner bottles.
4. Development clutch (K, Y, M, C):	Turns on/off the drive power to the development unit (K, Y, M, C).
5. Drum/Development drive motor (K, Y, M, C):	Drives the color drum unit and development unit (K, Y, M, C).
6. Paper feed clutch:	Switches the drive power between tray 1 and tray 2.
7. Paper feed motor:	Drives the paper feed mechanisms (tray 1/tray 2).

8. By-pass feed clutch:	Turns on/off the drive power to the by-pass pick-up, feed and separation rollers.
9. Registration motor:	Drives the registration roller.
10. By-pass/duplex feed motor:	Drives the by-pass pick-up, feed and separation roller, and duplex transport rollers.
11. Paper transfer contact motor:	Moves the paper transfer roller in contact with the image transfer belt.
12. ITB drive motor:	Drives the image transfer belt unit.
13. Duplex inverter motor:	Drives the duplex inverter rollers and duplex transport rollers.
14. Fusing/paper exit motor:	Drives the fusing unit and paper exit section.

Ex. 57 (C830 DN Field Service Manual).

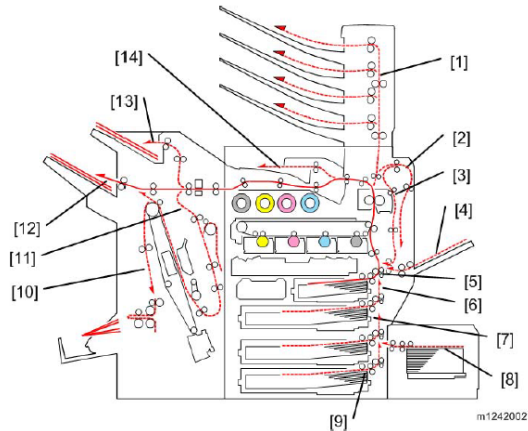

513. Claim limitation 1[f] is satisfied for at least the following reasons. As shown below, Ricoh Aficio SP C830DN has a duplexing unit which includes a duplex inverter (item 2) and duplex feed (3) to direct the paper along its path (as shown by the arrows) to reverse the paper so that the second side of the paper may be printed upon. The duplexing unit includes a paper transfer unit (shown as B) that is pivotable about a bracket (item A).

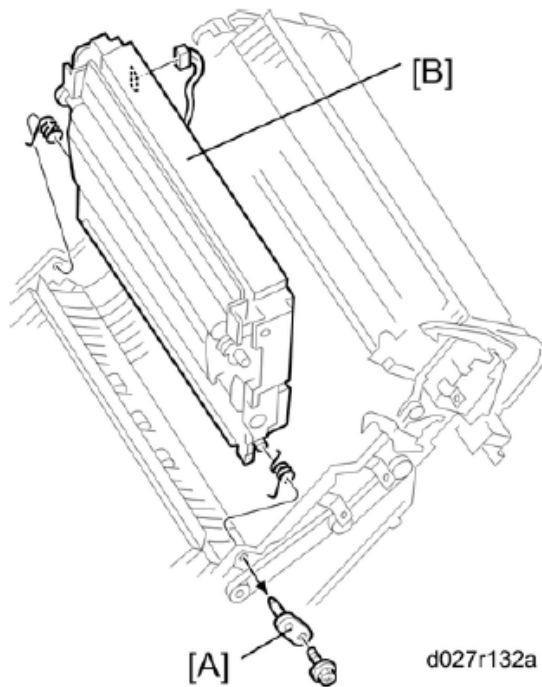

1. Mail bin	8. Tray 5: Optional LCT 1 200
2. Duplex inverter	9. Tray 4: Optional paper feed unit
3. Duplex feed	10. Finisher booklet stapler (Optional)
4. By-pass tray feed	11. Finisher stapler (Optional)
5. Tray 1 feed	12. Finisher upper tray (Optional)
6. Tray 2 feed	13. Finisher proof tray (Optional)
7. Tray 3: Optional paper feed unit/LCT	14. Output tray

Ex. 57 (C830 DN Field Service Manual).





- 7. Pivot bracket [A] ( x 1)
- 8. Paper transfer unit [B] ( x 1, 2 springs)

Ex. 57 (C830 DN Field Service Manual).

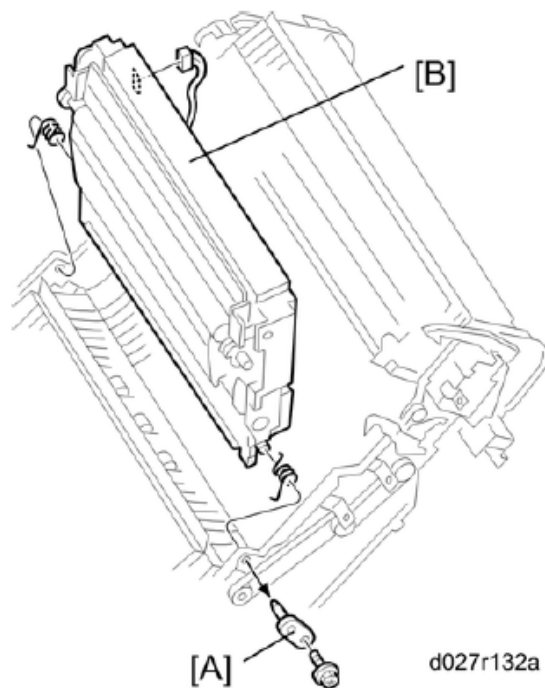
514. Claim limitation 1[g] is satisfied for at least the following reasons. As shown below, the paper transfer unit of the duplexing unit is attached to a hinge with a screw (as shown) and a bracket (item A). The hinge is substantially perpendicular to the base (as identified above).





7. Pivot bracket [A] ( x 1)
 8. Paper transfer unit [B] ( x 1, 2 springs)

Ex. 57 (C830 DN Field Service Manual).

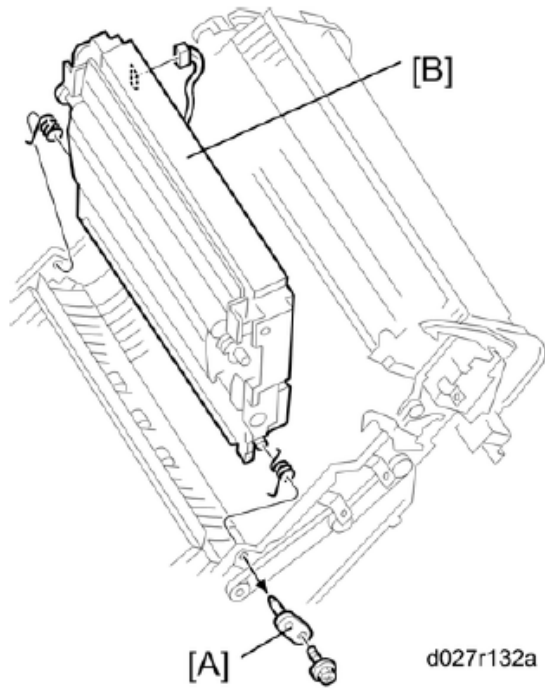

515. Claim limitation 1[h] is satisfied for at least the following reasons. As shown below, a support member of the hinge is comprised of a spring located between a paper transfer unit and the hinge. The straight portion of the bracket is a pin member that, when the bracket is secured, is part of the hinge that facilitates a pivoting motion relative to spring.

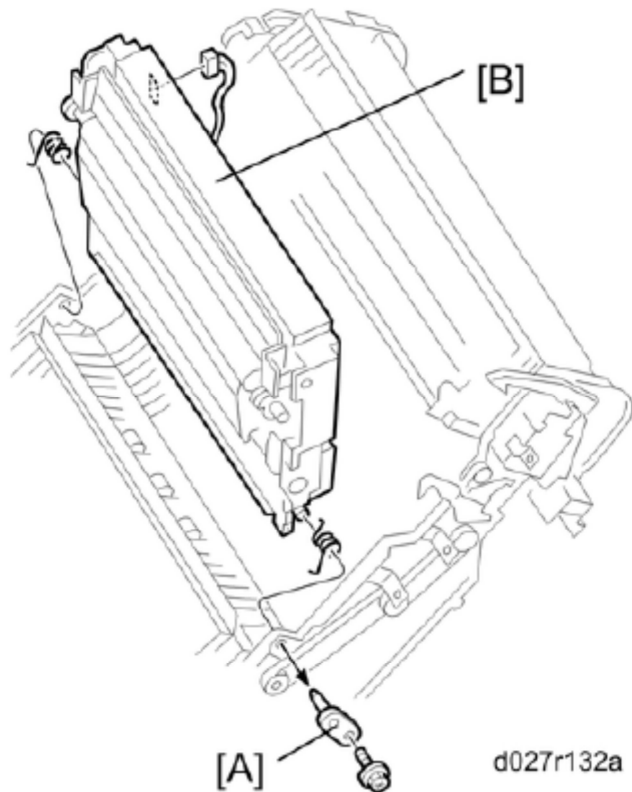

- 7. Pivot bracket [A] ( x 1)
- 8. Paper transfer unit [B] ( x 1, 2 springs)

Ex. 57 (C830 DN Field Service Manual).



- 7. Pivot bracket [A] ( x 1)
- 8. Paper transfer unit [B] ( x 1, 2 springs)

Ex. 57 (C830 DN Field Service Manual).

516. Ricoh also infringes under the doctrine of equivalents because it meets at least, and by way of example, the following claim limitation (s) of representative Claim 1 by performing substantially the same function as this limitation, performing this function in substantially the same way as this limitation, and achieving substantially the same results as claim limitation 1[a]. For example, and without limitation, Ricoh Aficio SP C830DN performs substantially the same function in substantially the same way and achieves substantially the same result at least because the base to support the printing apparatus during operation could be the structure into which trays 1 and 2 are housed.

517. As a result of Defendant's unlawful activities, MASA has suffered and will continue to suffer irreparable harm for which there is no adequate remedy at law. Accordingly, MASA is entitled to preliminary and/or permanent injunctive relief.

518. Defendant's infringement of the '022 Patent has injured and continues to injure MASA in an amount to be proven at trial.

COUNT XIX

(Direct Infringement of the '239 Patent pursuant to 35 U.S.C. § 271(a))

519. MASA repeats, realleges, and incorporates by reference, as if fully set forth herein, the allegations of the preceding paragraphs, as set forth above.

520. Defendant has infringed and continues to infringe one or more claims of the '239 Patent, including at least claim 1, in violation of 35 U.S.C. § 271(a).

521. Defendant's infringement is based upon literal infringement or infringement under the doctrine of equivalents, or both.

522. Defendant's acts of making, using, importing, selling, and/or offering for sale infringing products and services have been without the permission, consent, authorization, or license of MASA.

523. Defendant's infringement includes the manufacture, use, sale, importation and/or offer for sale of Defendant's products and services, such as Ricoh Aficio SP C830DN.

524. Claim 1 of the '239 Patent is recited below:

A device for moving a plurality of pressure rollers relative to respective counter rollers in a printing machine, said device comprising:

1[a] a plurality of movably supported pressure roller carriers, each supporting respectively one pressure roller, said pressure roller carriers being movable between a contact position and a non-contact position,

1[b] with each of said pressure roller carriers being biased via a biasing unit in a direction of the contact position; and

1[c] at least one actuation element connecting at least two pressure roller carriers to a shared actuation device, wherein the pressure roller carriers are adapted to automatically move to the non-contact position when the actuation device is in its non-energy mode.

525. As one example of how the '239 Accused Products infringe at least claim 1, Ricoh Aficio SP C830DN meets the limitations of claim 1 of the '239 Patent for at least the reasons described below.

526. An image of Ricoh Aficio SP C830DN is provided below:

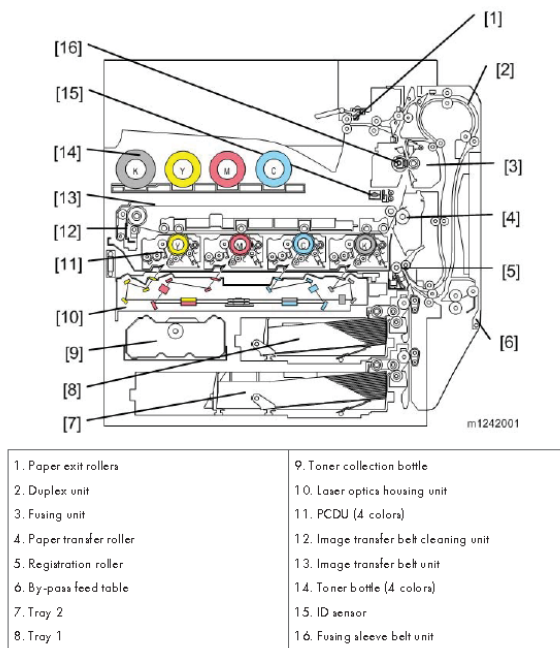

527. As a general matter and as described below, the limitations of claim 1 are satisfied because Ricoh Aficio SP C830DN have a plurality of pressure rollers such as the four Photoconductor Development Units (PCDU) shown as item 11 below.

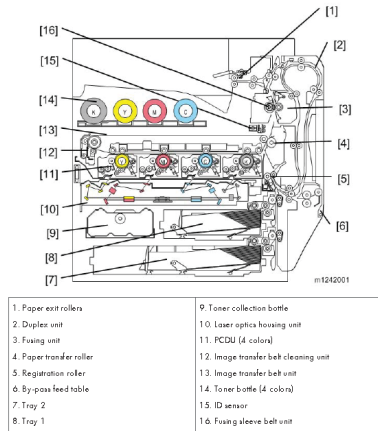

Ex. 54 (Ricoh Aficio SP C830DN-C831DN at p. 20 (22)).

528. Additionally, Ricoh Aficio SP C830DN have pressure rollers, each of which has a respective counter roller. As illustrated below, a pressure roller labeled “drum” has a respective counter roller labeled as an “image transfer roller” that is above and immediately adjacent to the “drum.”

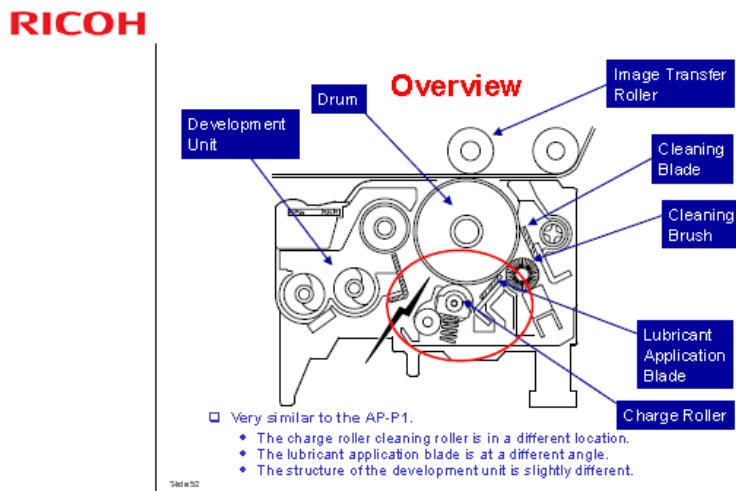

Ex. 58 (Ricoh Module Ap-P2 Training presentation at slide 51).

529. Claim limitation 1[a] is satisfied for at least the following reasons. As shown below, Ricoh Aficio SP C830DN includes a plurality of movably supported pressure roller carriers such as the four Photoconductor Development Units (PCDU) shown as item 11.

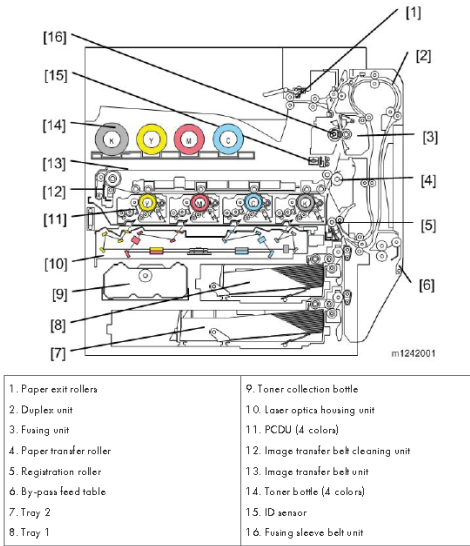

Ex. 54 (Ricoh Aficio SP C830DN-C831DN at p. 20 (22)).

530. Additionally, Ricoh Aficio SP C830DN includes a plurality of movably supported pressure roller carriers, one of which is shown a development unit labeled as “B.”

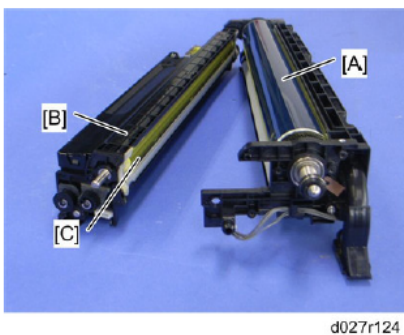

7. Drum unit [A] and Development Unit [B]

Ex. 54 (Ricoh Aficio SP C830DN-C831DN at p. 140 (142)).

531. Additionally, Ricoh Aficio SP C830DN includes pressure roller carriers being movable between a contact position and a non-contact position. As illustrated, each of the pressure roller carriers such as a development unit may be driven by a “drum/development drive motor – K” which has a “development clutch” to move the pressure roller carries between a contact position and a non-contact position such as when the development clutch is engaged and disengaged, respectively.

RICOH

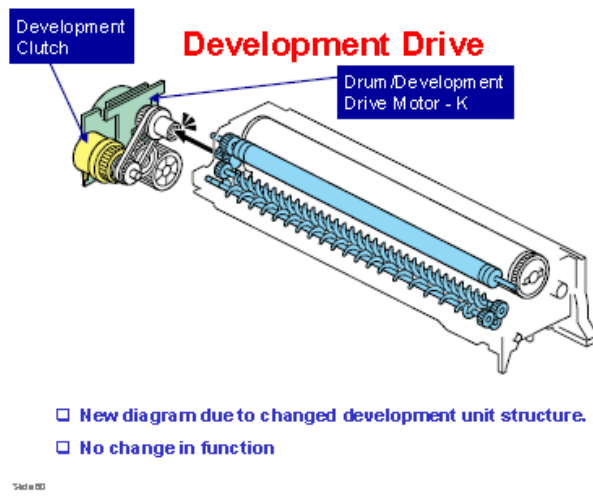

Ex. 58 (Ricoh Module Ap-P2 Training presentation at slide 60).

532. Claim limitation 1[b] is satisfied for at least the following reasons. As shown below, Ricoh Aficio SP C830DN includes pressure roller carriers being biased via a biasing unit. As illustrated, each pressure roller carrier may be biased via a biasing unit such as the unit labeled “development clutch” in the direction of its contact position when the “development clutch” is engaged.

RICOH

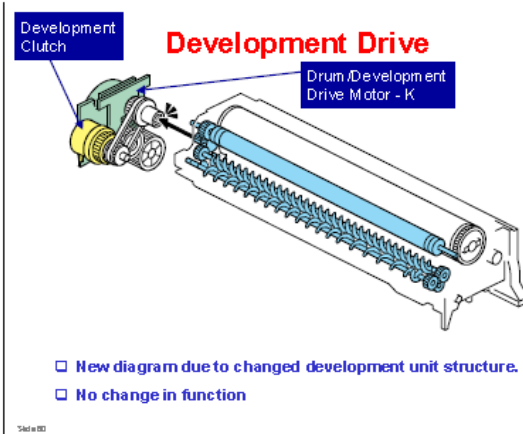

Ex. 58 (Ricoh Module Ap-P2 Training presentation at slide 60).

533. Claim limitation 1[c] is satisfied for at least the following reasons. As shown below, Ricoh Aficio SP C830DN includes an actuation element such as an electronic controller stated in the table, where such controller may be configurable with energy/non-energy modes.

Machines M124/M125 are successor models to Machines G188/G189. If you have experience with the predecessor products, the following information will be of help when you read this manual.

Different Points from Predecessor Products

Item	M124/M125	G188/G189
Controller Type	GW + Controller	GW Controller
New Fusing Unit without the Decurler	Yes	No
Fusing Unit	NEW QSU-DH fusing system	IH roller fusing system
SMC data	SD card download or printing	Printing only
Operation Panel	Tiltable Operation Panel Includes USB/SD slot	Stationary Operation Panel
USB 2.0/SD Slot	Standard	Optional
Data Overwrite Security, HDD Encryption	Included in the controller ROM	SD card

Ex.54 (Ricoh Aficio SP C830DN-C831DN at p. 27 (29)).

534. Additionally, Ricoh Aficio SP C830DN includes at least two pressure roller carriers found in color PCDUs (item 5) connected to a shared actuation device such as an image transfer belt (ITB) driven by ITB driver motor (item 12).

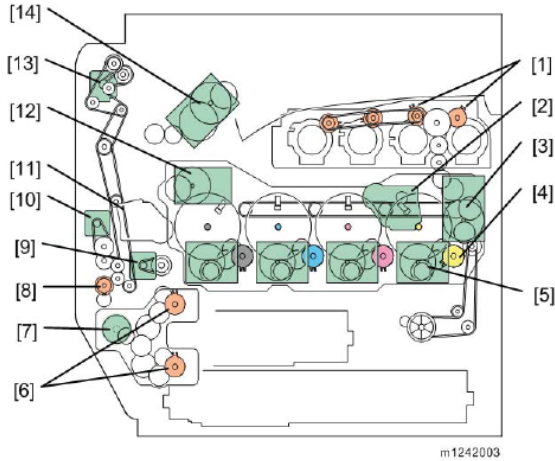

1. Toner supply clutch-K and -CMY:	Turns on/off the drive power to the toner supply unit (K and -CMY).
2. ITB (Image Transfer Belt) contact motor:	Moves the ITB into contact and away from the color PCDU's.
3. Toner transport motor:	Drives the toner attraction pumps and the toner collection coils from the PCDU's, from the transfer belt unit, and inside the toner collection bottle. Also rotates the toner bottles.
4. Development clutch (K, Y, M, C):	Turns on/off the drive power to the development unit (K, Y, M, C).
5. Drum/Development drive motor (K, Y, M, C):	Drives the color drum unit and development unit (K, Y, M, C).
6. Paper feed clutch:	Switches the drive power between tray 1 and tray 2.
7. Paper feed motor:	Drives the paper feed mechanisms (tray 1/tray 2).

8. By-pass feed clutch:	Turns on/off the drive power to the by-pass pick-up, feed and separation rollers.
9. Registration motor:	Drives the registration roller.
10. By-pass/ duplex feed motor:	Drives the by-pass pick-up, feed and separation roller, and duplex transport rollers.
11. Paper transfer contact motor:	Moves the paper transfer roller in contact with the image transfer belt.
12. ITB drive motor:	Drives the image transfer belt unit.
13. Duplex inverter motor:	Drives the duplex inverter rollers and duplex transport rollers.
14. Fusing/paper exit motor:	Drives the fusing unit and paper exit section.

Ex. 54 (Ricoh Aficio SP C830DN-C831DN at p. 22-23 (24-25)).

535. Furthermore, Ricoh Aficio SP C830DN include pressure roller carriers that may be adapted to automatically move to the non-contact position when the actuation device is in its non-energy mode. For example, each “drum/development drive motor - K” drives its movably supported pressure roller carrier that is adaptable to automatically move into a non-contact

position (i.e., disengagement with the drum/development unit) when the electronic controller is placed into its non-energy mode by a user selecting to make black-and-white images only.

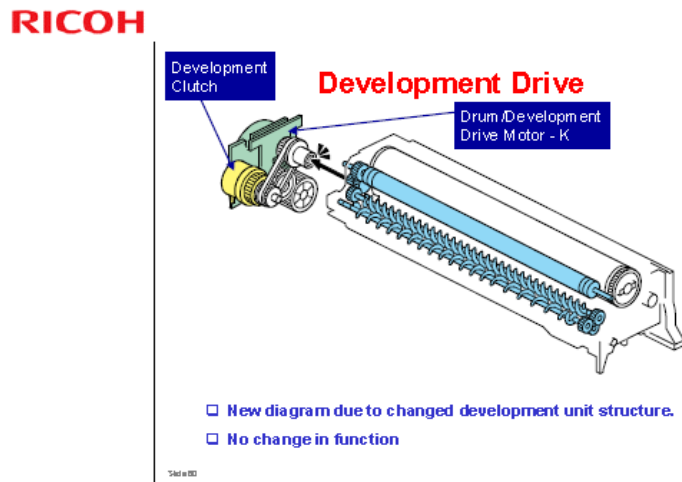

Ex. 58 (Ricoh Module Ap-P2 Training presentation at slide 60).

536. Ricoh also infringes under the doctrine of equivalents because it meets at least, and by way of example, the following claim limitation(s) of representative Claim 1 by performing substantially the same function as this limitation, performing this function in substantially the same way as this limitation, and achieving substantially the same results as claim element 1[a]. For example, and without limitation, Ricoh Aficio SP C830DN performs substantially the same function in substantially the same way and achieves substantially the same result at least because each one pressure roller could be one image transfer roller movable between a contact position and non-contact position.

537. As a result of Defendant's unlawful activities, MASA has suffered and will continue to suffer irreparable harm for which there is no adequate remedy at law. Accordingly, MASA is entitled to preliminary and/or permanent injunctive relief.

538. Defendant's infringement of the '239 Patent has injured and continues to injure MASA in an amount to be proven at trial.

PRAYER FOR RELIEF

WHEREFORE, MASA prays for judgment and relief as follows:

A. An entry of judgment holding Defendant has infringed and is infringing United States Patent Nos. 6,203,005, 6,305,684, 6,411,314, 6,462,756, 6,509,974, 6,554,269, 6,718,285, 6,724,998, 6,799,005, 6,993,278, 7,502,582, 7,658,375, 7,720,425, 8,005,415, 8,019,255, 8,220,795, 8,554,089, 8,591,022, and 8,805,239;

B. A preliminary and permanent injunction against Defendant and its respective officers, directors, agents, servants, affiliates, employees, divisions, branches, subsidiaries, parents and all others acting in active concert therewith from infringing United States Patent Nos. 6,203,005, 6,305,684, 6,411,314, 6,462,756, 6,509,974, 6,554,269, 6,718,285, 6,724,998, 6,799,005, 6,993,278, 7,502,582, 7,658,375, 7,720,425, 8,005,415, 8,019,255, 8,220,795, 8,554,089, 8,591,022, and 8,805,239 and for all further and proper injunctive relief pursuant to 35 U.S.C. § 283;

C. An award to MASA of such damages as it shall prove at trial against Defendant that are adequate to fully compensate MASA for Defendant's infringement of United States Patent Nos. 6,203,005, 6,305,684, 6,411,314, 6,462,756, 6,509,974, 6,554,269, 6,718,285, 6,724,998, 6,799,005, 6,993,278, 7,502,582, 7,658,375, 7,720,425, 8,005,415, 8,019,255, 8,220,795, 8,554,089, 8,591,022, and 8,805,239, said damages to be no less than a reasonable royalty;

D. A finding that this case is "exceptional" and an award to MASA of its costs and reasonable attorney's fees, as provided by 35 U.S.C. § 285;

E. An accounting of all infringing sales and revenues, together with post judgment interest and prejudgment interest from the first date of infringement of United States Patent Nos.

6,203,005, 6,305,684, 6,411,314, 6,462,756, 6,509,974, 6,554,269, 6,718,285, 6,724,998,
6,799,005, 6,993,278, 7,502,582, 7,658,375, 7,720,425, 8,005,415, 8,019,255, 8,220,795,
8,554,089, 8,591,022, and 8,805,239; and

F. Such further and other relief as the Court may deem proper and just.

DEMAND FOR JURY TRIAL

MASA demands a jury trial on all issues so triable.

Respectfully submitted,

Dated: April 16, 2018

KRAMER LEVIN NAFTALIS
& FRANKEL LLP

Paul J. Andre (*pro hac vice*)
Lisa Kobialka (*pro hac vice*)
James Hannah (*pro hac vice*)
990 Marsh Road
Menlo Park, CA 94025
Telephone: (650) 752-1700
Facsimile: (650) 752-1800
pandre@kramerlevin.com
lkobialka@kramerlevin.com
jhannah@kramerlevin.com

Mark A. Baghdassarian (*pro hac*
vice)
1177 Avenue of the Americas
New York, NY 10001
Tel: 212.715.9100
Fax: 212.715.8000
mbaghdassarian@kramerlevin.com

By: */s/ Daniel J. Fischer*
KOLEY JESSEN PC, LLO
Daniel J. Fischer
1125 South 103 Street
Suite 800
Omaha, NE 68124
Tel: (402) 343-3757
Fax: (402) 390-9005
dan.fischer@koleyjessen.com

Attorneys for Plaintiff
MASA LLC

Certificate of Service

I hereby certify that counsel of record who are deemed to have consented to electronic service are being served with a copy of this document via the Court's CM/ECF system on this 16th day of April, 2018.

/s/ Daniel J. Fischer