

**IN THE UNITED STATES DISTRICT COURT
FOR THE WESTERN DISTRICT OF TEXAS
WACO DIVISION**

CIRCUIT VENTURES LLC,

Plaintiff,

vs.

NXP SEMICONDUCTORS USA, INC.,

Defendant.

§
§
§
§
§
§
§
§
§
§

Case No: 6:19-cv-275

JURY TRIAL DEMANDED

ORIGINAL COMPLAINT FOR PATENT INFRINGEMENT

Plaintiff Circuit Ventures LLC (“Plaintiff” or “CV”), by and through its attorneys, files this Original Complaint against NXP Semiconductors USA, Inc. (“Defendant” or “NXP”) for infringement of United States Patent Nos. 7,256,683 (“the ‘683 Patent”); 7,834,744 (“the ‘744 Patent”); 8,816,869 (“the ‘869 Patent”); and 8,912,893 (“the ‘893 Patent”).

PARTIES AND JURISDICTION

1. This is an action for patent infringement under Title 35 of the United States Code. Plaintiff is seeking injunctive relief as well as damages.

2. Jurisdiction is proper in this Court pursuant to 28 U.S.C. §§ 1331 (Federal Question) and 1338(a) (Patents) because this is a civil action for patent infringement arising under the United States patent statutes.

3. Plaintiff is a Delaware LLC, with an office address of 825 Watters Creek Blvd., Building M, Suite 250, Allen, TX 75013.

4. Upon information and belief, Defendant is a Delaware corporation with its principal place of business located at 1109 McKay Drive, San Jose, CA 95131. This Court has personal

jurisdiction over Defendant because Defendant has committed, and continues to commit, acts of infringement in this District, has conducted business in this District, and/or has engaged in continuous and systematic activities in this District.

5. Upon information and belief, Defendant's instrumentalities that are alleged herein to infringe were and continue to be used, imported, offered for sale, and/or sold in this District.

VENUE

6. On information and belief, venue is proper in this District pursuant to 28 U.S.C. § 1400(b) because acts of infringement are occurring in this District and Defendant has a regular and established place of business in this District.

COUNT I **(INFRINGEMENT OF UNITED STATES PATENT NO. 7,256,683)**

7. Plaintiff incorporates paragraphs 1 through 6 herein by reference.

8. This cause of action arises under the patent laws of the United States and, in particular, under 35 U.S.C. §§ 271, et seq.

9. Plaintiff is the owner by assignment of the '683 Patent with sole rights to enforce the '683 patent and sue infringers.

10. A copy of the '683 Patent, titled "Circuit Monitoring Device," is attached hereto as Exhibit A.

11. The '683 Patent is valid, enforceable, and was duly issued in full compliance with Title 35 of the United States Code.

12. The claims of the '683 Patent recite a flexible system that can reproduce the function of a typical security management system. '683 Patent, 3:14-16. Typical systems are proprietary and components from one system will not work with components from another system. Additionally, any modifications to the hardware or software of a typical system usually must be

done by the original manufacturer. *Id.*, 1:16-24. Further, each manufacturer of typical security management system equipment specifies a particular value of field resistance for the last field device in a line of devices. *Id.*, 2:5-7. The problems with typical systems are especially apparent when an owner needs to upgrade or modify their system. *Id.*, 2:26-38.

Because each line connected to the system includes a field resistor of a particular value, the owner is forced to return to the original supplier of the SMS in order to provide an upgrade. Alternatively, the system owner must rewire each of the lines connected to the system and replace the field resistor with a different value, as specified by the supplier of the new SMS control unit. Where the resistor is built into the field device it cannot be changed and the system owner is forced to also replace each of the devices if it wants to change to a different brand of SMS control unit.

Id., 2:27-38. And, typical systems include an operator interface which is proprietary and cannot be changed by the user. *Id.*, 2:38-45. The system claimed in the '683 Patent allows for the retrofit of existing security management systems while using the existing circuitry wiring of the typical legacy system. *Id.*, 4:9-16.

13. Claim 8, for example, recites:

Apparatus for monitoring the status of a measurable parameter of an electrical circuit, the apparatus comprising:

measurement means for measuring the magnitude of said parameter and generating an analog signal representative of said magnitude;

analog to digital conversion means for generating from said analog signal a count value representative of said magnitude;

comparison means for comparing said count value with a threshold value and generating from the comparison a status signal, said status signal having two possible values which thereby indicates whether the count value is greater than or less than said threshold value;

transmission means for transmitting said status signal via a communications network to a display; and

display means for displaying an indication of said assigned status.

‘683 Patent, 9:48-64.

14. The components recited in the claims (such as in claim 8 for example) are configured, such that they operate in a non-conventional manner.

15. The components recited in the claims (such as in claim 8 for example) are configured so as to allow a user to set customized ranges of values to be set as parameters of end-of-line modules (i.e., parameters of a circuit). Generic processors cannot provide this functionality. As stated in the specification, “[t]he various threshold values . . . are preferably configured as variables which may be set as parameters of the EOL module. In this way, the EOL module may be configured to operate with a wide range of field resistors, thus enabling the EOL module to be retrofitted to a wide range of field circuits wherein the series and field resistors . . . already exist and cannot readily be changed.” ‘683 Patent, 7:1-8; see also *Id.*, 7:19-39 and 7:41-53.

Such . . . systems using EOL modules according to the present invention may be readily retrofitted to existing system, while utilizing the existing wiring regardless of existing resistance values. A system built in this way, either as an original installation or as a retrofit, provides a flexible and relatively inexpensive option which eliminates dependency on proprietary hardware and software.

Id., 8:27-34. Thus, the ‘683 Patent specification clarifies that the claimed components, performing the claimed functionality, are not conventional or generic.

16. Collectively, the claimed embodiments in the ‘683 Patent provide new solutions to problems of traditional security monitoring systems. These solutions are enabled by non-generic components functioning in a non-conventional manner.

17. The ‘683 Patent solves a problem with the art that is rooted in computer technology. The ‘683 Patent does not merely recite the performance of some business practice known from the pre-Internet world along with the requirement to perform it on the Internet.

18. Upon information and belief, Defendant has infringed and continues to infringe one or more claims, including at least Claim 8 of the '683 Patent by making, using, importing, selling, and/or offering for sale, field devices, wireless systems, circuit monitoring devices, and/or components for such systems, which are covered by one or more claims of the '683 Patent. Defendant causes infringement by its customers and users and encourages the use of accused devices through distribution, support and customer services. Defendant has infringed and continues to infringe the '683 Patent directly in violation of 35 U.S.C. § 271.

19. Regarding Claim 8, Defendant makes, uses, sells and/or offers for sale an apparatus for monitoring the status of a measurable parameter of an electrical circuit. For example, Defendant provides an IoT Gateway Solution (SLN-IOT-GPI) for monitoring the status of a measurable parameter (such as voltage, current, resistance, conductivity and/or capacitance) of a sensor associated with the circuit. Infringing products and certain aspects of this element are illustrated in the screenshots below and/or in those provided in connection with other allegations herein.

FIGURE 1: SLN-IOT-GPI: IDEX FOR GENERAL PURPOSE IOT SYSTEMS



Source: <https://www.nxp.com/docs/en/fact-sheet/MODIOTFRAMEWORKFS.pdf>, page 2

SLN-IOT-GPI IDEX FEATURES

The SLN-IOT-GPI IDEX includes hardware and software, drivers, protocol and connectivity stacks as well as Linux BSP support.

- ▶ FCC/CE/IC certified
- ▶ Multi-protocol support for Thread, ZigBee, Wi-Fi and Ethernet
- ▶ Supports large node networks (>= 250 nodes)
- ▶ Commissioning through NFC and Smart App
- ▶ Wi-Fi and Ethernet northbound to the cloud
- ▶ Over-the-air programming via Multicast
- ▶ Smartphone app support
- ▶ i.MX6UL SOM
- ▶ Kinetis® KW22D512 or KW41Z Thread microcontroller
- ▶ JN5179 ultra low power ZigBee 3.0 and IEEE802.15.4 Module
- ▶ PN7120 NFC controller
- ▶ A70CM secure element

Source: <https://www.nxp.com/docs/en/fact-sheet/MODIOTFRAMEWORKFS.pdf>, page 2

SOFTWARE AND TOOLS TABLE

SLN-IOT-GPI IDEX SOFTWARE	DEVICE
Linux® Yocto BSP with full drivers and connectivity	i.MX6UL MCUs
MQTT client library	i.MX6UL MCUs
Thread Linux host software SDK	i.MX6UL MCUs
Gateway and end device registration with cloud	i.MX6UL MCUs
Start-up script for Wi-Fi® client service	i.MX6UL MCUs
Config file to load Wi-Fi firmware	i.MX6UL MCUs
Controls front panel LEDs	i.MX6UL MCUs
Communication bridge between cloud and end device	i.MX6UL MCUs
NFC commissioning of gateway and end devices	i.MX6UL MCUs
Thread end device controller	i.MX6UL MCUs
ZigBee end device controller	i.MX6UL MCUs
Black box Thread stack for KW41Z on gateway	Kinetis W series MCUs
Black box ZigBee stack for JN on gateway	JN MCUs
Black box stack for NFC on gateway	PN7120 NFC controller
SMARTPHONE APP SOFTWARE	
Pre-compiled Android and iOS applications to manage gateway	Smartphone
END DEVICE FIRMWARE	
MENP-KW41Z, MENP-KW22D, MENP-JN5179, MENP-JN5169, FRDM-K64F+MCR20, FRDM-KW41Z, FRDM-KW22D	Multiple

Source: <https://www.nxp.com/docs/en/fact-sheet/MODIOTFRAMEWORKFS.pdf>, page 2

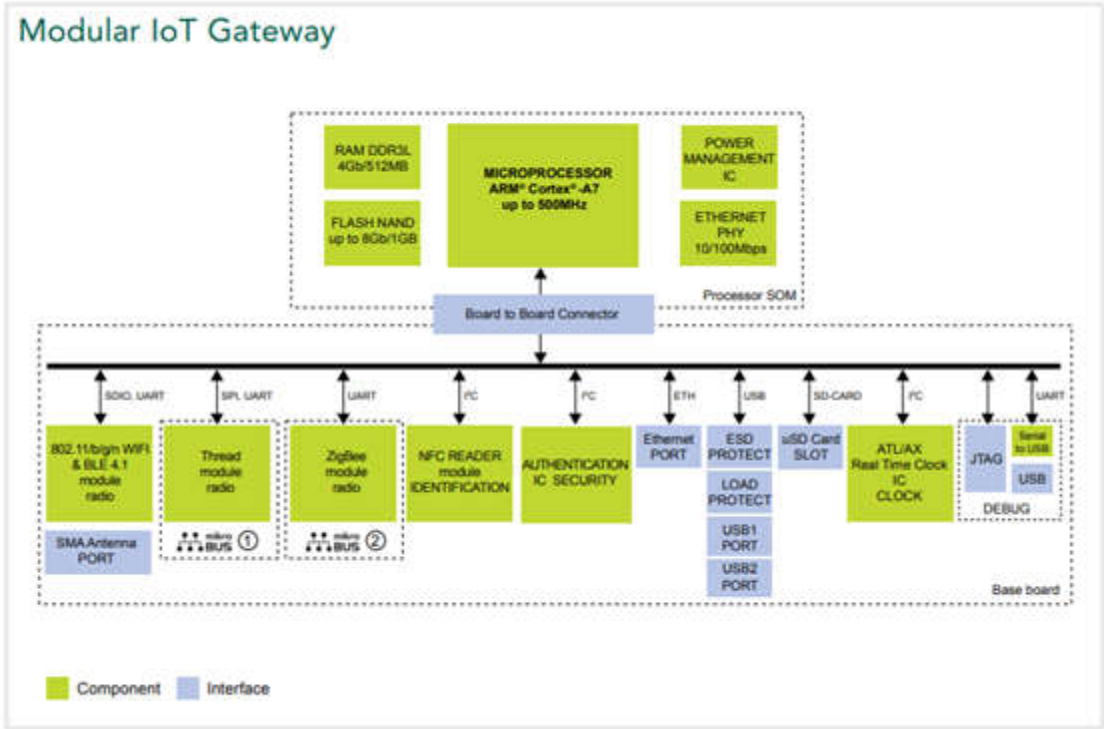

Source: <https://www.nxp.com/docs/en/fact-sheet/MODIOTFRAMEWORKFS.pdf>, page 3

IoT System Functionality Requirements

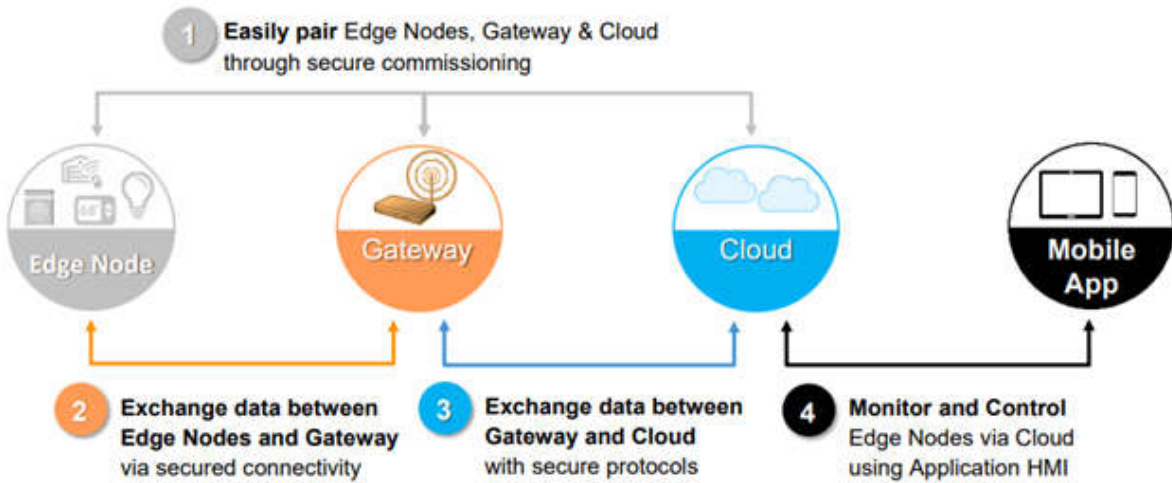

Source: <https://www.nxp.com/docs/en/supporting-information/DEV-PLATFORMS-IOT-SYSTEMS.pdf>, page 5

THERMO 4 click	Features the LM75A digital temperature sensor and a thermal watchdog with a range from -55 °C to +125 °C. The click is designed to run on either 3.3V or 5V power supply.
NFC Tag 2 click	Carries the NT3H2111 NTAG I2C energy harvesting NFC Forum Type 2 Tag from NXP. The click is designed to run on a 3.3V power supply only.
eINK click	Adapter for connecting eINK displays with very low power consumption and the ability to retain the information, even after disconnecting from the power source. Features the LM75A temperature sensor and thermal watchdog.
NFC click	Add-on board designed with the PN7120 versatile near field communications controller for contactless payment systems, electronic ticketing, smartcards, retail and advertising applications.
Diff pressure click	Diff pressure click carries the MPXV5010DP signal conditioned, temperature compensated and calibrated pressure sensor with two axial ports to accommodate industrial grade tubing.
Pulse Width Modulation click	Simple solution designed with the PCA9685 controller for 16 PWM outputs through a single I2C interface. You can use it to control anything from a simple LED strip to a complex robot with a multitude of moving parts.
Altitude click	Altitude click features the pressure sensor MPL3115A2 , which provides accurate pressure/altitude (20-bit) and temperature (12-bit) data.
TILTnSHAKE click	Features the MMA8491Q 3-axis multifunctional digital accelerometer that can also be configured as a 45-degree tilt sensor.
H-Bridge Click	Features the MCS4933 dual H-bridge driver to provide reasonably high current while driving the connected load with up to 7V. It is an ideal solution for light 3D printer elements driving, for precision actuators, an accurate positioning of various moving elements by using stepper motors, and similar applications.
H-Bridge 2 Click	Features the MPC17510 H-Bridge DC motor driver which implements a set of features that provide trouble-free operation of the connected motor, such as the undervoltage detection, shoot-through current protection, efficient output stage MOSFETs with low R _{DS(on)} , level shifted output for an external MOSFET control and more.

Source: <https://www.nxp.com/support/developer-resources/rapid-prototyping/docking-stations-and-click-boards:DOCKING-STATIONS-CLICK-BOARDS>

20. The infringing products provide a measurement means for measuring the magnitude of said parameter and generating an analog signal representative of said magnitude. For example, the IoT Gateway Solution integrates with at least one of the sensors (such pressure sensor MPL3115A2, LM75A digital temperature sensor, etc.) to measure the magnitude of the parameter of the circuit and generates an analog signal (such as voltage and/or current) representative of the measured parameter associated with the sensor. Certain aspects of this element are illustrated in the screenshots below and/or in those provided in connection with other allegations herein.

d Modules: Overview

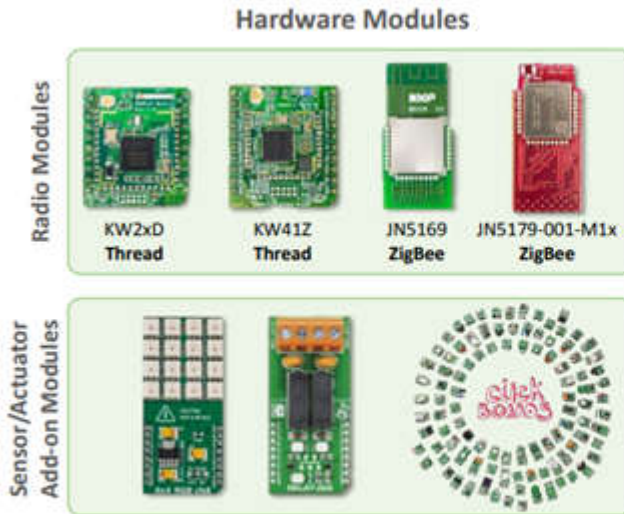

Source: <https://www.nxp.com/docs/en/supporting-information/DEV-PLATFORMS-IOT-SYSTEMS.pdf>, page 15

THERMO 4 click	Features the LM75A digital temperature sensor and a thermal watchdog with a range from -55 °C to +125 °C. The click is designed to run on either 3.3V or 5V power supply.
NFC Tag 2 click	Carries the NTAG I2C energy harvesting NFC Forum Type 2 Tag from NXP. The click is designed to run on a 3.3V power supply only.
eInk click	Adapter for connecting eInk displays with very low power consumption and the ability to retain the information, even after disconnecting from the power source. Features the LM75A temperature sensor and thermal watchdog.
NFC click	Add-on board designed with the PN7120 versatile near field communications controller for contactless payment systems, electronic ticketing, smartcards, retail and advertising applications.
Diff pressure click	Diff pressure click carries the MPXV5010DP signal conditioned, temperature compensated and calibrated pressure sensor with two axial ports to accommodate industrial grade tubing.
Pulse Width Modulation click	Simple solution designed with the PCA9685 controller for 16 PWM outputs through a single I2C interface. You can use it to control anything from a simple LED strip to a complex robot with a multitude of moving parts.
Altitude click	Altitude click features the pressure sensor MPL3115A2 , which provides accurate pressure/altitude (20-bit) and temperature (12-bit) data.
TILTnSHAKE click	Features the MMA8451Q 3-axis multifunctional digital accelerometer that can also be configured as a 45-degree tilt sensor.
H-Bridge Click	Features the MC34933 dual H-bridge driver to provide reasonably high current while driving the connected load with up to 7V. It is an ideal solution for light 3D printer elements driving, for precision actuators, an accurate positioning of various moving elements by using stepper motors, and similar applications.
H-Bridge 2 Click	Features the MPC17510 H-Bridge DC motor driver which implements a set of features that provide trouble-free operation of the connected motor, such as the undervoltage detection, shoot-through current protection, efficient output stage MOSFETs with low R _{DS(on)} , level shifted output for an external MOSFET control and more.

Source: <https://www.nxp.com/support/developer-resources/rapid-prototyping/docking-stations-and-click-boards:DOCKING-STATIONS-CLICK-BOARDS>

LM75A: Digital temperature sensor and thermal watchdog

[Follow](#) 
[OVERVIEW](#)
[DOCUMENTATION](#)
[TOOLS & SOFTWARE](#)
[BUY/PARAMETRICS](#)
[PACKAGE/QUALITY](#)
[TRAINING & SUPPORT](#)

Jump To

[Overview & Features](#)
[Development Boards](#)
[Complementary Products](#)

Overview

The LM75A is a temperature-to-digital converter using an on-chip bandgap temperature sensor and Sigma-delta A-to-D conversion technique. The device is also a thermal detector providing an overtemperature detection output. The LM75A contains a number of data registers: Configuration register (Conf) to store the device settings such as device operation mode, OS operation mode, OS polarity and OS fault queue as described in [Section 7 "Functional description"](#); temperature register (Temp) to store the digital temp reading, and set-point registers (Tos and Thyst) to store programmable overtemperature shutdown and hysteresis limits, that can be communicated by a controller via the 2-wire serial I²C-bus interface. The device also includes an open-drain output (OS) which becomes active when the temperature exceeds the programmed limits. There are three selectable logic address pins so that eight devices can be connected on the same bus without address conflict.

The LM75A can be configured for different operation conditions. It can be set in a normal mode to periodically monitor the ambient temperature, or in shutdown mode to minimize power consumption. The OS output operates

Features

- Pin-for-pin replacement for industry standard LM75 and offers improved temperature resolution of 0.125 °C and specification of a single part over power supply range from 2.8 V to 5.5 V
- Small 8-pin package types: SO8 and TSSOP8
- I²C-bus interface with up to 8 devices on the same bus
- Power supply range from 2.8 V to 5.5 V
- Temperatures range from -55 °C to +125 °C
- 11-bit ADC that offers a temperature resolution of 0.125 °C
- Temperature accuracy of:
 - +2 °C from -25 °C to +100 °C
 - +3 °C from -55 °C to +125 °C
- Programmable temperature threshold and hysteresis set points
- Supply current of 3.5 uA in shutdown mode for power conservation
- Stand-alone operation as thermostat at power-up

Source: <https://www.nxp.com/products/sensors/other-sensors/ic-temperature-sensors/digital-temperature-sensor-and-thermal-watchdog:LM75A>

MPL3115A2: 20 to 110 kPa, Absolute Digital Pressure Sensor

[Follow](#) 
[OVERVIEW](#)
[DOCUMENTATION](#)
[TOOLS & SOFTWARE](#)
[BUY/PARAMETRICS](#)
[PACKAGE/QUALITY](#)
[TRAINING & SUPPORT](#)

Jump To

[Overview & Features](#)
[Development Boards](#)
[Target Applications](#)
[Complementary Products](#)

Overview

The MPL3115A2 is a compact piezoresistive absolute pressure sensor with an I²C interface. MPL3115 has a wide operating range of 20 kPa to 110 kPa, a range that covers all surface elevations on Earth. The fully internally compensated MEMS in conjunction with an embedded high resolution 24-bit equivalent ADC provide accurate pressure [Pascals] /altitude [meters] and temperature [degrees Celsius] data. The internal processing in MPL3115A2 removes compensation and unit conversion load from the system MCU, simplifying system design.

MPL3115A2's advanced ASIC has multiple user programmable modes such as power saving, interrupt and autonomous data acquisition modes, including programmed acquisition cycle timing, and poll-only modes. Typical active supply current is 40 uA per measurement-second for a stable 10 cm output resolution.

Features

- Calibrated range: 50 kPa to 110 kPa absolute pressure
- Operating range: 20 kPa to 110 kPa absolute pressure
- I²C digital output interface (up to 400 kHz)
- Fully compensated internally
- Direct reading:
 - Pressure: 20-bit measurement [Pascals]
 - Altitude: 20-bit measurement [meters]
 - Temperature: 12-bit measurement [degrees Celsius]
- Programmable Interrupts
- Autonomous Data Acquisition:
 - Embedded 32-Sample FIFO
 - Data logging up to 12 days using the FIFO
 - 1 second to 9 hour data acquisition rate
- 1.95 V to 3.6 V Supply Voltage, internally regulated
- 1.6 V to 3.6 V Digital Interface Supply Voltage
- Operating temperature from -40 °C to +85 °C

Source: <https://www.nxp.com/products/sensors/pressure-sensors/barometric-pressure-15-to-115-kpa/20-to-110-kpa-absolute-digital-pressure-sensor:MPL3115A2>

21. The infringing products provide an analog to digital conversion means for

generating from said analog signal a count value representative of said magnitude. For example, the IoT Gateway Solution comprises an analog to digital converter to generate a count value associated with the analog signal (such as voltage and/or current) representative of the measured parameter of the sensor. Certain aspects of this element are illustrated in the screenshots below and/or in those provided in connection with other allegations herein.

THERMO 4 click	Features the LM75A digital temperature sensor and a thermal watchdog with a range from -55 °C to +125 °C. The click is designed to run on either 3.3V or 5V power supply.
NFC Tag 2 click	Carries the NT3H2111 NTAG I2C energy harvesting NFC Forum Type 2 Tag from NXP. The click is designed to run on a 3.3V power supply only.
eINK click	Adapter for connecting eINK displays with very low power consumption and the ability to retain the information, even after disconnecting from the power source. Features the LM75A temperature sensor and thermal watchdog.
NFC click	Add-on board designed with the PN7120 versatile near field communications controller for contactless payment systems, electronic ticketing, smartcards, retail and advertising applications.
Diff pressure click	Diff pressure click carries the MPXV5010DP signal conditioned, temperature compensated and calibrated pressure sensor with two axial ports to accommodate industrial grade tubing.
Pulse Width Modulation click	Simple solution designed with the PCA9685 controller for 16 PWM outputs through a single I2C interface. You can use it to control anything from a simple LED strip to a complex robot with a multitude of moving parts.
Altitude click	Altitude click features the pressure sensor MPL3115A2 , which provides accurate pressure/altitude (20-bit) and temperature (12-bit) data.
TILTnSHAKE click	Features the MMAB491Q 3-axis multifunctional digital accelerometer that can also be configured as a 45-degree tilt sensor.
H-Bridge Click	Features the MC34933 dual H-bridge driver to provide reasonably high current while driving the connected load with up to 7V. It is an ideal solution for light 3D printer elements driving, for precision actuators, an accurate positioning of various moving elements by using stepper motors, and similar applications.
H-Bridge 2 Click	Features the MPC17510 H-Bridge DC motor driver which implements a set of features that provide trouble-free operation of the connected motor, such as the undervoltage detection, shoot-through current protection, efficient output stage MOSFETs with low RDSON, level shifted output for an external MOSFET control and more.

Source: <https://www.nxp.com/support/developer-resources/rapid-prototyping/docking-stations-and-click-boards:DOCKING-STATIONS-CLICK-BOARDS>

MPL3115A2: 20 to 110 kPa, Absolute Digital Pressure Sensor

Follow

- OVERVIEW
- DOCUMENTATION
- TOOLS & SOFTWARE
- BUY/PARAMETRICS
- PACKAGE/QUALITY
- TRAINING & SUPPORT

Jump To

- Overview & Features
- Development Boards
- Target Applications
- Complementary Products

Overview

The MPL3115A2 is a compact piezoresistive absolute pressure sensor with an I2C interface. MPL3115 has a wide operating range of 20 kPa to 110 kPa, a range that covers all surface elevations on Earth. The fully internally compensated MEMS in conjunction with an embedded high resolution 24-bit equivalent ADC provide accurate pressure [Pascals] /altitude [meters] and temperature [degrees Celsius] data. The internal processing in MPL3115A2 removes compensation and unit conversion load from the system MCU, simplifying system design.

MPL3115A2's advanced ASIC has multiple user programmable modes such as power saving, interrupt and autonomous data acquisition modes, including programmed acquisition cycle timing, and poll-only modes. Typical active supply current is 40 uA per measurement-second for a stable 10 cm output resolution.

Features

- Calibrated range: 50 kPa to 110 kPa absolute pressure
- Operating range: 20 kPa to 110 kPa absolute pressure
- I2C digital output interface (up to 400 kHz)
- Fully compensated internally
- Direct reading:
 - Pressure: 20-bit measurement [Pascals]
 - Altitude: 20-bit measurement [meters]
 - Temperature: 12-bit measurement [degrees Celsius]
- Programmable Interrupts
- Autonomous Data Acquisition:
 - Embedded 32-Sample FIFO
 - Data logging up to 12 days using the FIFO
 - 1 second to 9 hour data acquisition rate
- 1.95 V to 3.6 V Supply Voltage, internally regulated
- 1.6 V to 3.6 V Digital Interface Supply Voltage
- Operating temperature from -40 °C to +85 °C

Source: <https://www.nxp.com/products/sensors/pressure-sensors/barometric-pressure-15-to-115-kpa/20-to-110-kpa-absolute-digital-pressure-sensor:MPL3115A2>

Modular IoT Gateway: *Hardware Block Diagram*

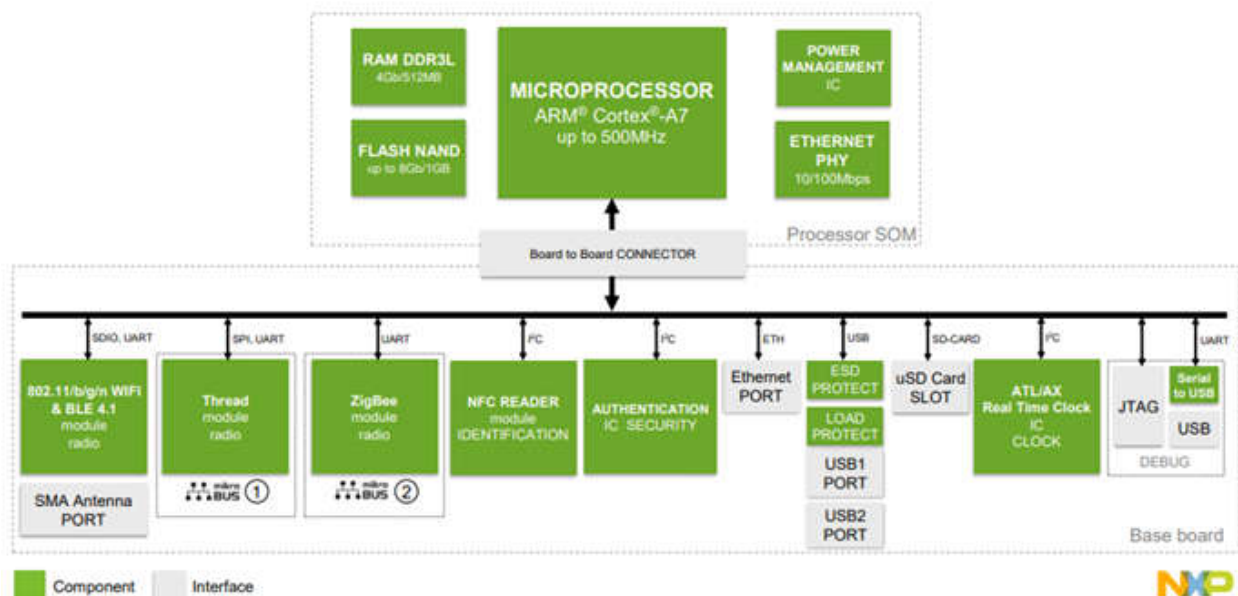

Source: <https://www.nxp.com/docs/en/supporting-information/DEV-PLATFORMS-IOT-SYSTEMS.pdf>, page 12

22. The infringing products provide a comparison means for comparing said count value with a threshold value and generating from the comparison a status signal, said status signal

having two possible values which thereby indicates whether the count value is greater than or less than said threshold value. For example, the IoT Gateway Solution integrates with the Modular IoT Gateway and at least one of the sensors (such as pressure sensor MPL3115A2, LM75A digital temperature sensor, etc.) via a wireless communication network and compares the count value with a threshold value which generates a status signal (such as alert, notification and/or alarm). The status signal have at least two possible values (high or low) which is greater than or less than the threshold value. Certain aspects of this element are illustrated in the screenshots below and/or in those provided in connection with other allegations herein.

Modular IoT Gateway: *Hardware Block Diagram*

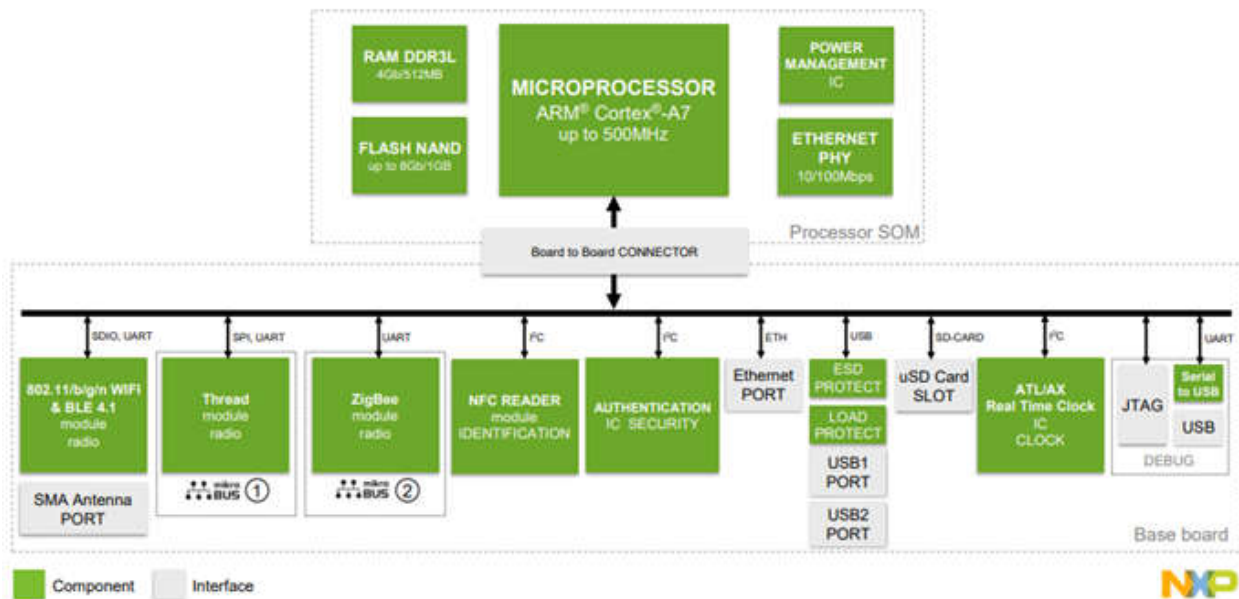

Source: <https://www.nxp.com/docs/en/supporting-information/DEV-PLATFORMS-IOT-SYSTEMS.pdf>, page 12

IDEx for General Purpose IoT Systems: *Functional Specifications*

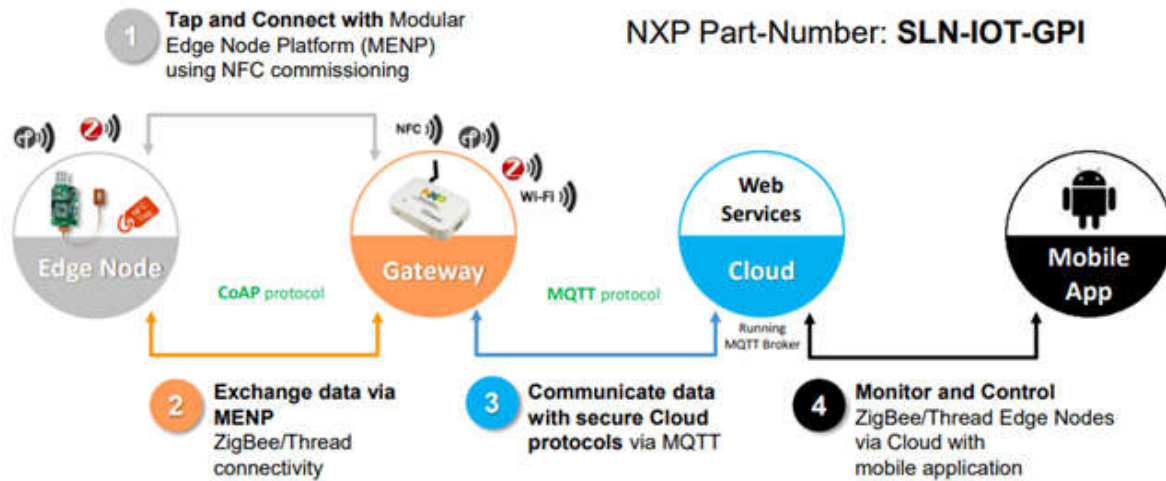

Source: <https://www.nxp.com/docs/en/supporting-information/DEV-PLATFORMS-IOT-SYSTEMS.pdf>, page 21

SLN-IOT-GPI IDEx FEATURES

The SLN-IOT-GPI IDEx includes hardware and software, drivers, protocol and connectivity stacks as well as Linux BSP support.

- ▶ FCC/CE/IC certified
- ▶ Multi-protocol support for Thread, ZigBee, Wi-Fi and Ethernet
- ▶ Supports large node networks (>= 250 nodes)
- ▶ Commissioning through NFC and Smart App
- ▶ Wi-Fi and Ethernet northbound to the cloud
- ▶ Over-the-air programming via Multicast
- ▶ Smartphone app support
- ▶ i.MX6UL SOM
- ▶ Kinetis® KW22D512 or KW41Z Thread microcontroller
- ▶ JN5179 ultra low power ZigBee 3.0 and IEEE802.15.4 Module
- ▶ PN7120 NFC controller
- ▶ A70CM secure element

Source: <https://www.nxp.com/docs/en/fact-sheet/MODIOTFRAMEWORKFS.pdf>, page 2

SOFTWARE AND TOOLS TABLE

SLN-IOT-GPI IDEX SOFTWARE	DEVICE
Linux® Yocto BSP with full drivers and connectivity	i.MX6UL MCUs
MQTT client library	i.MX6UL MCUs
Thread Linux host software SDK	i.MX6UL MCUs
Gateway and end device registration with cloud	i.MX6UL MCUs
Start-up script for Wi-Fi® client service	i.MX6UL MCUs
Config file to load Wi-Fi firmware	i.MX6UL MCUs
Controls front panel LEDs	i.MX6UL MCUs
Communication bridge between cloud and end device	i.MX6UL MCUs
NFC commissioning of gateway and end devices	i.MX6UL MCUs
Thread end device controller	i.MX6UL MCUs
ZigBee end device controller	i.MX6UL MCUs
Black box Thread stack for KW41Z on gateway	Kinetis W series MCUs
Black box ZigBee stack for JN on gateway	JN MCUs
Black box stack for NFC on gateway	PN7120 NFC controller
SMARTPHONE APP SOFTWARE	
Pre-compiled Android and iOS applications to manage gateway	Smartphone
END DEVICE FIRMWARE	
MENP-KW41Z, MENP-KW22D, MENP-JN5179, MENP-JN5169, FRDM-K64F+MCR20, FRDM-KW41Z, FRDM-KW22D	Multiple

Source: <https://www.nxp.com/docs/en/fact-sheet/MODIOTFRAMEWORKFS.pdf>, page 2

23. The infringing products provide a transmission means for transmitting said status signal via a communications network to a display. For example, the IoT Gateway Solution comprises a communication module (“transmission means”) for at least one of the sensors (such as pressure sensor MPL3115A2, LM75A digital temperature sensor, etc.) via a wireless network (such as Wi-Fi/BT/BLE 4.1 and/or ZigBee) to a Modular IoT Gateway and/or a mobile computing device (“display”). Certain aspects of this element are illustrated in the screenshots provided in connection with other allegations herein.

Modular Edge Node Platform

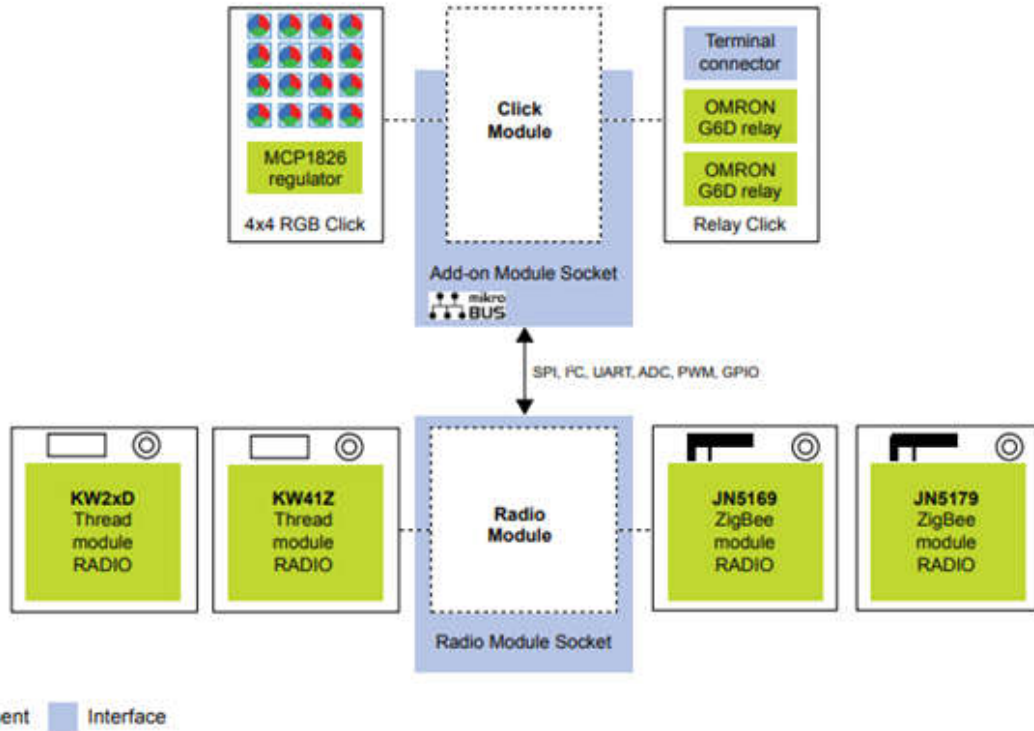

Source: <https://www.nxp.com/docs/en/fact-sheet/MODIOTFRAMEWORKFS.pdf>, page 3

Complexity of IoT System Development

EDGE DIRECT TO TOWER	EDGE NODES	CONNECTIVITY	GATEWAY / ROUTING	COMMUNICATIONS TO THE CLOUD	CLOUD PLATFORMS
Cellular • GSM • LTE • CAT 1 • CAT M • NB IoT SigFox LoRa	 	 ZigBee THREAD Bluetooth	 	Ethernet SigFox LoRa Cellular • GSM • LTE • CAT 1 • CAT M • NB IoT	• Cloud Services • Google • Azure • IBM Watson
SOFTWARE SERVICES					
MCU OS and BSP: FreeRTOS, mbed OS, Zephyr OS					
MPU OS and BSP: Linux, OpenWRT, Android Things, Windows10					
Generic System: Security, Over-the-Air-Programming (OTAP), OOB Configuration					
Application Layer Support: BT Profiles, CoAP, Fairhair, IoTX, MQTT, OCF, OpenAIS, Weave, ZCLIP, ZigBee 3.0					
NFC Commissioning: Tap and Connect, BLE Commissioning, Intrepid Smart App Commissioning					
Application HMI: Computer GUI interface, iOS/Android Phone App, Voice Control					

Fragmented market with thousands of use case combinations



Source: <https://www.nxp.com/docs/en/supporting-information/DEV-PLATFORMS-IOT-SYSTEMS.pdf>, page 4

Integrated Development Experience (IDEx) for General Purpose IoT Systems

- Includes Pre-Configured Modular IoT Gateway and Modular Edge Node Platform



Modular IoT Gateway

- Modular IoT Gateway Base board
- i.MX6UL SOM
- Wi-Fi/BT/BLE 4.1
- Thread/BLE Radio
- ZigBee Radio
- NFC Reader
- A7x Secure Element



Modular Edge Node Platform (MENP)

- Simple Edge Node Base board
- ZigBee Radio
- Thread/BLE Radio
- NFC Tag
- RGB Click Module

- Includes Connectivity and Security Software

Modular IoT Gateway

- Linux OS and component drivers (BSP)
- Connectivity and Cloud Protocols
- NFC Connectivity and Cloud commissioning
- Secure Over-The-Air Programming
- Application software

Modular Edge Node Platform (MENP)

- FreeRTOS with SDK peripheral drivers
- Connectivity Stacks (ZigBee, Thread)
- NFC Connectivity commissioning





Shipping TODAY as NXP Part-Number: SLN-IOT-GPI



Source: <https://www.nxp.com/docs/en/supporting-information/DEV-PLATFORMS-IOT-SYSTEMS.pdf>, page 10

24. The infringing products provide a display means for displaying an indication of said assigned status. For example, the IoT Gateway Solution provides a mobile application to display an indication (such as alarm, notification and/or alerts) of at least one of the coupled sensors (such as pressure sensor MPL3115A2, LM75A digital temperature sensor, etc.) based on the signal assigned status on a computing device (such as smartphone, tablet and/or computer). Certain aspects of this element are illustrated in the screenshots below and/or in those provided in connection with other allegations herein.

Complexity of IoT System Development

EDGE DIRECT TO TOWER	EDGE NODES	CONNECTIVITY	GATEWAY / ROUTING	COMMUNICATIONS TO THE CLOUD	CLOUD PLATFORMS
Cellular • GSM • LTE • CAT 1 • CAT M • NB IoT SigFox LoRa				Ethernet  • Integration / Interfaces / Glue Cellular SigFox LoRa • GSM • LTE • CAT 1 • CAT M • NB IoT	• Cloud Services • Google • Azure • IBM Watson
SOFTWARE SERVICES					
MCU OS and BSP: FreeRTOS, mbed OS, Zephyr OS					
MPU OS and BSP: Linux, OpenWRT, Android Things, Windows10					
Generic System: Security, Over-the-Air-Programming (OTAP), OOB Configuration					
Application Layer Support: BT Profiles, CoAP, Fairhair, IoTX, MQTT, OCF, OpenAIS, Weave, ZCLIP, ZigBee 3.0					
NFC Commissioning: Tap and Connect, BLE Commissioning, Intrepid Smart App Commissioning					
Application HMI: Computer GUI interface, iOS/Android Phone App, Voice Control					

Fragmented market with thousands of use case combinations



Source: <https://www.nxp.com/docs/en/supporting-information/DEV-PLATFORMS-IOT-SYSTEMS.pdf>, page 4

IoT System Functionality Requirements

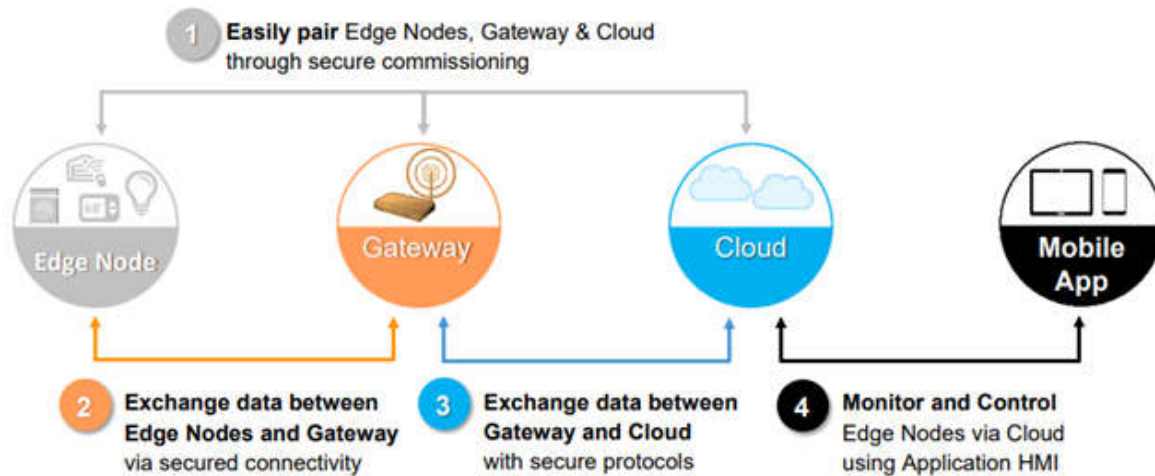

Source: <https://www.nxp.com/docs/en/supporting-information/DEV-PLATFORMS-IOT-SYSTEMS.pdf>, page 5

IDEx for General Purpose IoT System Use Case: *Lighting Control*

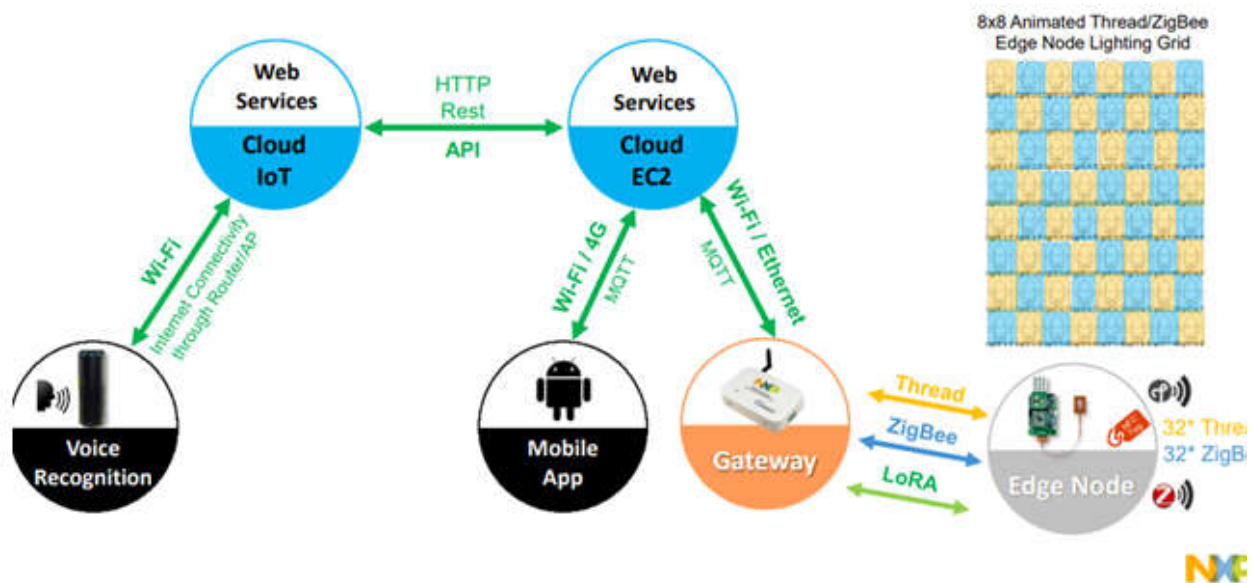

Source: <https://www.nxp.com/docs/en/supporting-information/DEV-PLATFORMS-IOT-SYSTEMS.pdf>, page 22

25. Defendant’s actions complained of herein will continue unless Defendant is enjoined by this court.

26. Defendant’s actions complained of herein are causing irreparable harm and monetary damage to Plaintiff and will continue to do so unless and until Defendant is enjoined and restrained by this Court.

27. Plaintiff is in compliance with 35 U.S.C. § 287.

COUNT II **(INFRINGEMENT OF UNITED STATES PATENT NO. 7,834,744)**

28. Plaintiff incorporates paragraphs 1 through 27 herein by reference.

29. This cause of action arises under the patent laws of the United States and, in particular, under 35 U.S.C. §§ 271, et seq.

30. Plaintiff is the owner by assignment of the ‘744 Patent with sole rights to enforce the ‘744 Patent and sue infringers.

31. A copy of the ‘744 Patent, titled “Circuit Monitoring Device,” is attached hereto as

Exhibit B.

32. The '744 Patent is valid, enforceable, and was duly issued in full compliance with Title 35 of the United States Code.

33. The claims of the '744 recite subject matter that is similar to that recited in the claims of the '683 Patent (discussed above in connection with Count I). The specification of the '744 Patent discloses problems of prior systems and non-generic solutions in a manner similar to the specification of the '683 Patent (discussed above in connection with Count I).

35. The components recited in the claims (such as in claim 1 for example) are configured, such that they operate in a non-conventional manner.

36. The components recited in the claims (such as in claim 1 for example) are configured so as to allow a user to set customized ranges of values to be set as parameters of end-of-line modules (i.e., parameters of a circuit). Generic processors cannot provide this functionality. The '744 Patent specification clarifies that the claimed components, performing the claimed functionality, are not conventional or generic.

37. Collectively, the claimed embodiments in the '744 Patent provide new solutions to problems of traditional security monitoring systems. These solutions are enabled by non-generic components functioning in a non-conventional manner.

38. The '744 Patent solves a problem with the art that is rooted in computer technology. The '744 Patent does not merely recite the performance of some business practice known from the pre-Internet world along with the requirement to perform it on the Internet.

39. Upon information and belief, Defendant has infringed and continues to infringe one or more claims, including at least Claim 1, of the '744 Patent by making, using, importing, selling, and/or offering for sale, field devices, wireless systems, circuit monitoring devices, and/or

components for such systems covered by one or more claims of the ‘744 Patent. Defendant causes infringement by its customers and users and encourages the use of accused devices through distribution, support and customer services. Defendant has infringed and continues to infringe the ‘744 Patent directly in violation of 35 U.S.C. § 271.

40. Regarding Claim 1, Defendant makes, uses, sells and/or offers for sale an apparatus for monitoring a circuit and for coupling to a central system. For example, Defendant provides an IoT Gateway Solution (SLN-IOT-GPI) for monitoring at least one of the sensors (such as pressure sensor MPL3115A2, LM75A digital temperature sensor, etc.). Further, the IoT Gateway Solution comprising the Modular IoT Gateway (“central system”) couples to the sensor using wireless network (such as Wi-Fi/BT/BLE 4.1 and/or ZigBee). Infringing products and certain aspects of this element are illustrated in the screenshots below and/or in those provided in connection with other allegations herein.

FIGURE 1: SLN-IOT-GPI: IDEX FOR GENERAL PURPOSE IOT SYSTEMS



Source: <https://www.nxp.com/docs/en/fact-sheet/MODIOTFRAMEWORKFS.pdf>, page 2

SLN-IOT-GPI IDEX FEATURES

The SLN-IOT-GPI IDEX includes hardware and software, drivers, protocol and connectivity stacks as well as Linux BSP support.

- ▶ FCC/CE/IC certified
- ▶ Multi-protocol support for Thread, ZigBee, Wi-Fi and Ethernet
- ▶ Supports large node networks (>= 250 nodes)
- ▶ Commissioning through NFC and Smart App
- ▶ Wi-Fi and Ethernet northbound to the cloud
- ▶ Over-the-air programming via Multicast
- ▶ Smartphone app support
- ▶ i.MX6UL SOM
- ▶ Kinetis® KW22D512 or KW41Z Thread microcontroller
- ▶ JN5179 ultra low power ZigBee 3.0 and IEEE802.15.4 Module
- ▶ PN7120 NFC controller
- ▶ A70CM secure element

Source: <https://www.nxp.com/docs/en/fact-sheet/MODIOTFRAMEWORKFS.pdf>, page 2

SOFTWARE AND TOOLS TABLE

SLN-IOT-GPI IDEX SOFTWARE	DEVICE
Linux® Yocto BSP with full drivers and connectivity	i.MX6UL MCUs
MQTT client library	i.MX6UL MCUs
Thread Linux host software SDK	i.MX6UL MCUs
Gateway and end device registration with cloud	i.MX6UL MCUs
Start-up script for Wi-Fi® client service	i.MX6UL MCUs
Config file to load Wi-Fi firmware	i.MX6UL MCUs
Controls front panel LEDs	i.MX6UL MCUs
Communication bridge between cloud and end device	i.MX6UL MCUs
NFC commissioning of gateway and end devices	i.MX6UL MCUs
Thread end device controller	i.MX6UL MCUs
ZigBee end device controller	i.MX6UL MCUs
Black box Thread stack for KW41Z on gateway	Kinetis W series MCUs
Black box ZigBee stack for JN on gateway	JN MCUs
Black box stack for NFC on gateway	PN7120 NFC controller
SMARTPHONE APP SOFTWARE	
Pre-compiled Android and iOS applications to manage gateway	Smartphone
END DEVICE FIRMWARE	
MENP-KW41Z, MENP-KW22D, MENP-JN5179, MENP-JN5169, FRDM-K64F+MCR20, FRDM-KW41Z, FRDM-KW22D	Multiple

Source: <https://www.nxp.com/docs/en/fact-sheet/MODIOTFRAMEWORKFS.pdf>, page 2

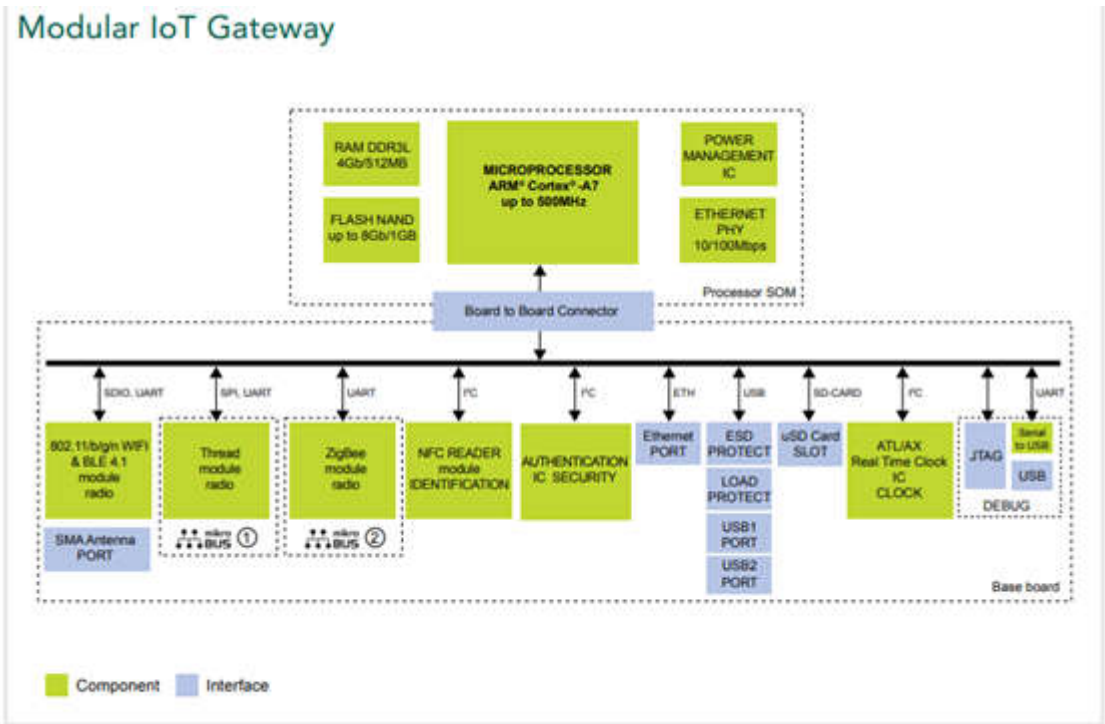

Source: <https://www.nxp.com/docs/en/fact-sheet/MODIOTFRAMEWORKFS.pdf>, page 3

IoT System Functionality Requirements

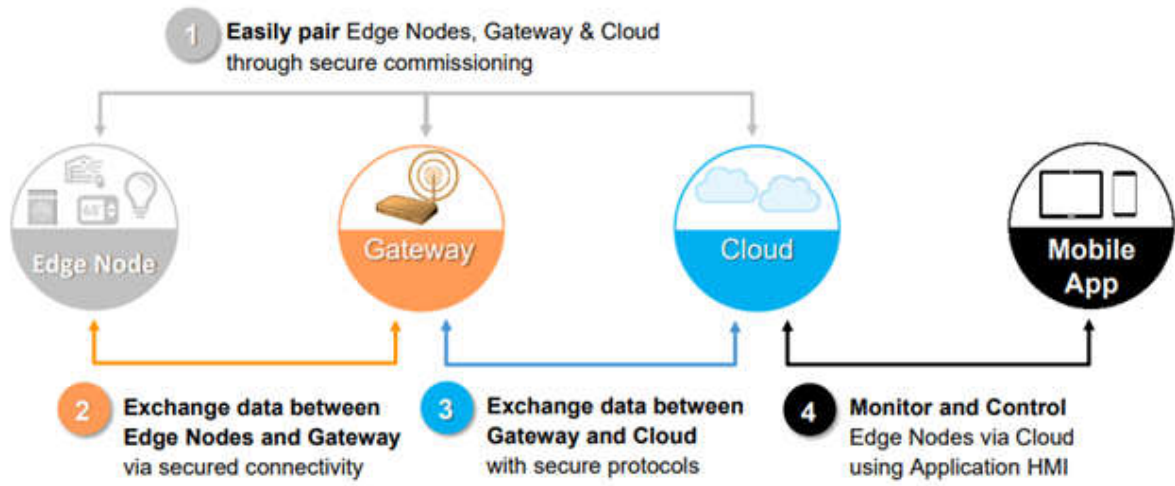

Source: <https://www.nxp.com/docs/en/supporting-information/DEV-PLATFORMS-IOT-SYSTEMS.pdf>, page 5

THERMO 4 click	Features the LM75A digital temperature sensor and a thermal watchdog with a range from -55 °C to +125 °C. The click is designed to run on either 3.3V or 5V power supply.
NFC Tag 2 click	Carries the NT3H2111 NTAG I2C energy harvesting NFC Forum Type 2 Tag from NXP. The click is designed to run on a 3.3V power supply only.
eINK click	Adapter for connecting eINK displays with very low power consumption and the ability to retain the information, even after disconnecting from the power source. Features the LM75A temperature sensor and thermal watchdog.
NFC click	Add-on board designed with the PN7120 versatile near field communications controller for contactless payment systems, electronic ticketing, smartcards, retail and advertising applications.
Diff pressure click	Diff pressure click carries the MPXV50100P signal conditioned, temperature compensated and calibrated pressure sensor with two axial ports to accommodate industrial grade tubing.
Pulse Width Modulation click	Simple solution designed with the PCA9685 controller for 16 PWM outputs through a single I2C interface. You can use it to control anything from a simple LED strip to a complex robot with a multitude of moving parts.
Altitude click	Altitude click features the pressure sensor MPL3115A2 , which provides accurate pressure/altitude (20-bit) and temperature (12-bit) data.
TILTnSHAKE click	Features the MMA8491Q 3-axis multifunctional digital accelerometer that can also be configured as a 45-degree tilt sensor.
H-Bridge Click	Features the MC34933 dual H-bridge driver to provide reasonably high current while driving the connected load with up to 7V. It is an ideal solution for light 3D printer elements driving, for precision actuators, an accurate positioning of various moving elements by using stepper motors, and similar applications.
H-Bridge 2 Click	Features the MPC17510 H-Bridge DC motor driver which implements a set of features that provide trouble-free operation of the connected motor, such as the undervoltage detection, shoot-through current protection, efficient output stage MOSFETs with low R _{DS(on)} , level shifted output for an external MOSFET control and more.

Source: <https://www.nxp.com/support/developer-resources/rapid-prototyping/docking-stations-and-click-boards:DOCKING-STATIONS-CLICK-BOARDS>

41. The infringing products provide a circuit module to determine a status of the circuit. For example, the Gateway Solution integrates with at least one of the sensors (“circuit module”) (such as pressure sensor [MPL3115A2](#), [LM75A](#) digital temperature sensor, etc.) to determine a status (such as pressure and/or temperature) of the sensor. Certain aspects of this element are illustrated in the screenshots below and/or those provided in connection with other allegations herein.

LM75A: Digital temperature sensor and thermal watchdog

[Follow](#)
[OVERVIEW](#)
[DOCUMENTATION](#)
[TOOLS & SOFTWARE](#)
[BUY/PARAMETRICS](#)
[PACKAGE/QUALITY](#)
[TRAINING & SUPPORT](#)

Jump To

- [Overview & Features](#)
- [Development Boards](#)
- [Complementary Products](#)

Overview

The LM75A is a temperature-to-digital converter using an on-chip bandgap temperature sensor and Sigma-delta A-to-D conversion technique. The device is also a thermal detector providing an overtemperature detection output. The LM75A contains a number of data registers: Configuration register (Conf) to store the device settings such as device operation mode, OS operation mode, OS polarity and OS fault queue as described in [Section 7 "Functional description"](#); temperature register (Temp) to store the digital temp reading, and set-point registers (Tos and Thyst) to store programmable overtemperature shutdown and hysteresis limits, that can be communicated by a controller via the 2-wire serial I²C-bus interface. The device also includes an open-drain output (OS) which becomes active when the temperature exceeds the programmed limits. There are three selectable logic address pins so that eight devices can be connected on the same bus without address conflict.

The LM75A can be configured for different operation conditions. It can be set in a normal mode to periodically monitor the ambient temperature, or in shutdown mode to minimize power consumption. The OS output operates

Features

- Pin-for-pin replacement for industry standard LM75 and offers improved temperature resolution of 0.125 °C and specification of a single part over power supply range from 2.8 V to 5.5 V
- Small 8-pin package types: SO8 and TSSOP8
- I²C-bus interface with up to 8 devices on the same bus
- Power supply range from 2.8 V to 5.5 V
- Temperatures range from -55 °C to +125 °C
- 11-bit ADC that offers a temperature resolution of 0.125 °C
- Temperature accuracy of:
 - +2 °C from -25 °C to +100 °C
 - +3 °C from -55 °C to +125 °C
- Programmable temperature threshold and hysteresis set points
- Supply current of 3.5 uA in shutdown mode for power conservation
- Stand-alone operation as thermostat at power-up

Source: <https://www.nxp.com/products/sensors/other-sensors/ic-temperature-sensors/digital-temperature-sensor-and-thermal-watchdog:LM75A>

MPL3115A2: 20 to 110 kPa, Absolute Digital Pressure Sensor

[Follow](#)
[OVERVIEW](#)
[DOCUMENTATION](#)
[TOOLS & SOFTWARE](#)
[BUY/PARAMETRICS](#)
[PACKAGE/QUALITY](#)
[TRAINING & SUPPORT](#)

Jump To

- [Overview & Features](#)
- [Development Boards](#)
- [Target Applications](#)
- [Complementary Products](#)

Overview

The MPL3115A2 is a compact piezoresistive absolute pressure sensor with an I2C interface. MPL3115 has a wide operating range of 20 kPa to 110 kPa, a range that covers all surface elevations on Earth. The fully internally compensated MEMS in conjunction with an embedded high resolution 24-bit equivalent ADC provide accurate pressure [Pascals] /altitude [meters] and temperature [degrees Celsius] data. The internal processing in MPL3115A2 removes compensation and unit conversion load from the system MCU, simplifying system design.

MPL3115A2's advanced ASIC has multiple user programmable modes such as power saving, interrupt and autonomous data acquisition modes, including programmed acquisition cycle timing, and poll-only modes. Typical active supply current is 40 uA per measurement-second for a stable 10 cm output resolution.

Features

- Calibrated range: 50 kPa to 110 kPa absolute pressure
- Operating range: 20 kPa to 110 kPa absolute pressure
- I²C digital output interface (up to 400 kHz)
- Fully compensated internally
- Direct reading:
 - Pressure: 20-bit measurement [Pascals]
 - Altitude: 20-bit measurement [meters]
 - Temperature: 12-bit measurement [degrees Celsius]
- Programmable Interrupts
- Autonomous Data Acquisition:
 - Embedded 32-Sample FIFO
 - Data logging up to 12 days using the FIFO
 - 1 second to 9 hour data acquisition rate
- 1.95 V to 3.6 V Supply Voltage, internally regulated
- 1.6 V to 3.6 V Digital Interface Supply Voltage
- Operating temperature from -40 °C to +85 °C

Source: <https://www.nxp.com/products/sensors/pressure-sensors/barometric-pressure-15-to-115-kpa/20-to-110-kpa-absolute-digital-pressure-sensor:MPL3115A2>

d Modules: Overview

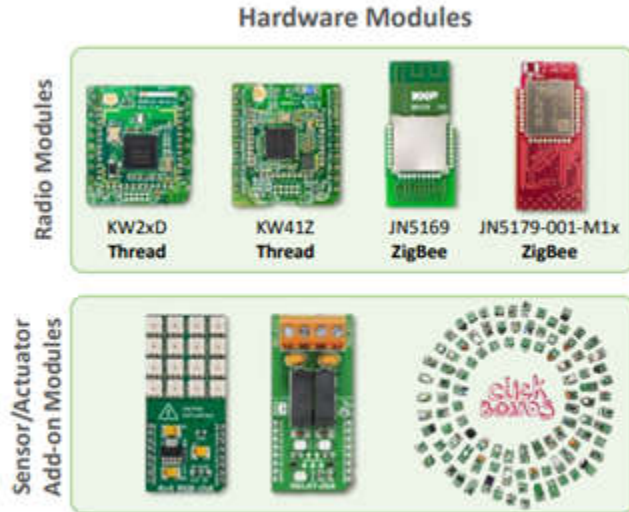

Source: <https://www.nxp.com/docs/en/supporting-information/DEV-PLATFORMS-IOT-SYSTEMS.pdf>, page 15

42. The infringing products provide a network communications module coupled to the circuit module to communicate a signal indicative of the assigned status to the central system via a network, said network communications module limiting all status communications with the central system to only the signal indicative of the assigned status. For example, the IoT Gateway Solution comprises a network communication module coupled with at least one of the sensors (such as pressure sensor MPL3115A2, LM75A digital temperature sensor, etc.) to communicate a signal indicative of the assigned status (such as temperature and/or pressure) to a Modular IoT Gateway (“central system”) via a wireless network (such as Wi-Fi/BT/BLE 4.1 and/or ZigBee). The communication module is dedicated to communicate with the central system to indicate the status of the signal from at least one of the sensor. Certain aspects of this element are illustrated in the screenshots below and/or those provided in connection with other allegations herein.

Modular Edge Node Platform

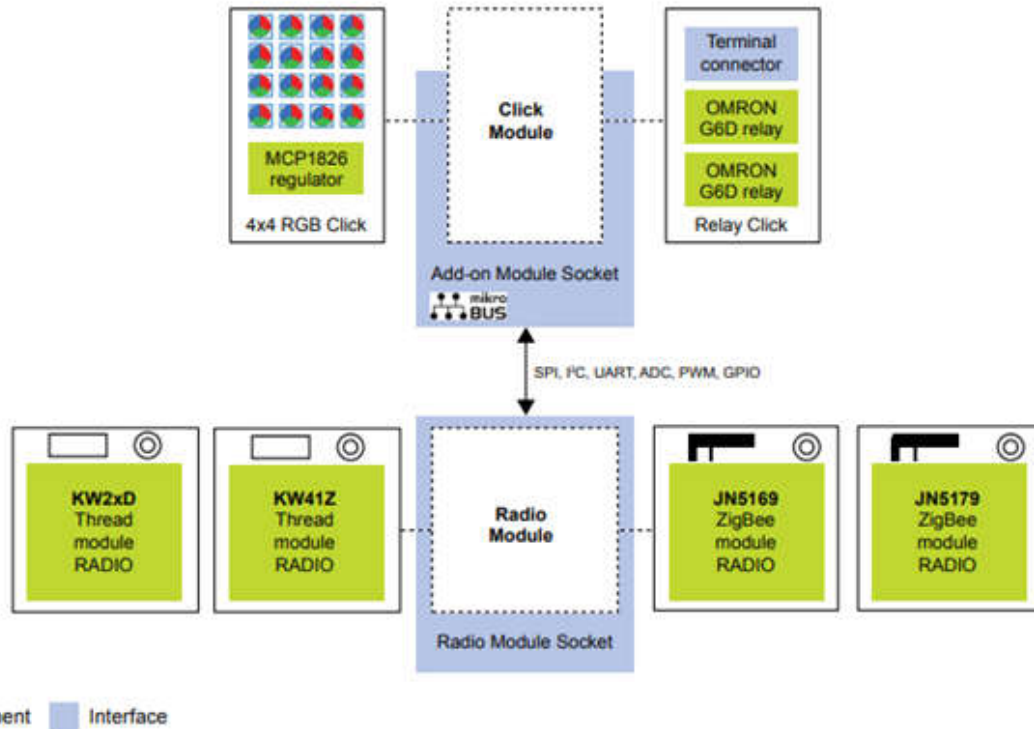

Source: <https://www.nxp.com/docs/en/fact-sheet/MODIOTFRAMEWORKFS.pdf>, page 3

Complexity of IoT System Development

EDGE DIRECT TO TOWER	EDGE NODES	CONNECTIVITY	GATEWAY / ROUTING	COMMUNICATIONS TO THE CLOUD	CLOUD PLATFORMS
Cellular • GSM • LTE • CAT 1 • CAT M • NB IoT SigFox LoRa				Ethernet WiFi Cellular SigFox • GSM • LTE • CAT 1 • CAT M • NB IoT LoRa	• Cloud Services • Google • Azure • IBM Watson
SOFTWARE SERVICES					
MCU OS and BSP: FreeRTOS, mbed OS, Zephyr OS					
MPU OS and BSP: Linux, OpenWRT, Android Things, Windows10					
Generic System: Security, Over-the-Air-Programming (OTAP), OOB Configuration					
Application Layer Support: BT Profiles, CoAP, Fairhair, IoTX, MQTT, OCF, OpenAIS, Weave, ZCLIP, ZigBee 3.0					
NFC Commissioning: Tap and Connect, BLE Commissioning, Intrepid Smart App Commissioning					
Application HMI: Computer GUI interface, iOS/Android Phone App, Voice Control					

Fragmented market with thousands of use case combinations



Source: <https://www.nxp.com/docs/en/supporting-information/DEV-PLATFORMS-IOT-SYSTEMS.pdf>, page 4

Integrated Development Experience (IDEx) for General Purpose IoT Systems

- Includes Pre-Configured Modular IoT Gateway and Modular Edge Node Platform



Modular IoT Gateway

- Modular IoT Gateway Base board
- i.MX6UL SOM
- Wi-Fi/BT/BLE 4.1
- Thread/BLE Radio
- ZigBee Radio
- NFC Reader
- A7x Secure Element



Modular Edge Node Platform (MENP)

- Simple Edge Node Base board
- ZigBee Radio
- Thread/BLE Radio
- NFC Tag
- RGB Click Module

- Includes Connectivity and Security Software

Modular IoT Gateway

- Linux OS and component drivers (BSP)
- Connectivity and Cloud Protocols
- NFC Connectivity and Cloud commissioning
- Secure Over-The-Air Programming
- Application software

Modular Edge Node Platform (MENP)

- FreeRTOS with SDK peripheral drivers
- Connectivity Stacks (ZigBee, Thread)
- NFC Connectivity commissioning

Shipping TODAY as NXP Part-Number: SLN-IOT-GPI



Source: <https://www.nxp.com/docs/en/supporting-information/DEV-PLATFORMS-IOT-SYSTEMS.pdf>, page 10

43. The infringing products provide a display to present an indication of a status of the circuit based on the signal indicative of the assigned status, wherein the circuit module measures a magnitude of a parameter of the circuit and generates a count value representative of said magnitude. For example, the IoT Gateway Solution provides a mobile application support to display an indication (such as alarm, notification and/or alerts) of at least one of the coupled sensors (pressure sensor MPL3115A2, LM75A digital temperature sensor, etc.) based on the signal assigned status (such as temperature and/or pressure) on a computing device (such as smartphone, tablet and/or computer). The sensor measures a magnitude of a parameter (such as resistance, voltage and/or current) and generates a count value representative of at least one of the magnitude. Certain aspects of this element are illustrated in the screenshots provided in connection with other allegations herein.

44. Defendant's actions complained of herein will continue unless Defendant is enjoined by this court.

45. Defendant's actions complained of herein are causing irreparable harm and

monetary damage to Plaintiff and will continue to do so unless and until Defendant is enjoined and restrained by this Court.

46. Plaintiff is in compliance with 35 U.S.C. § 287.

COUNT III
(INFRINGEMENT OF UNITED STATES PATENT NO. 8,816,869)

47. Plaintiff incorporates paragraphs 1 through 46 herein by reference.

48. This cause of action arises under the patent laws of the United States and, in particular, under 35 U.S.C. §§ 271, et seq.

49. Plaintiff is the owner by assignment of the ‘869 Patent with sole rights to enforce the ‘869 Patent and sue infringers.

50. A copy of the ‘869 Patent, titled “Circuit Monitoring Device,” is attached hereto as Exhibit C.

51. The ‘869 Patent is valid, enforceable, and was duly issued in full compliance with Title 35 of the United States Code.

52. The claims of the ‘869 recite subject matter that is similar to that recited in the claims of the ‘683 Patent (discussed above in connection with Count I). The specification of the ‘869 Patent discloses problems of prior systems and non-generic solutions in a manner similar to the specification of the ‘683 Patent (discussed above in connection with Count I).

53. The components recited in the claims (such as in claim 1 for example) are configured, such that they operate in a non-conventional manner.

54. The components recited in the claims (such as in claim 1 for example) are configured so as to allow a user to set customized ranges of values to be set as parameters of end-of-line modules (i.e., parameters of a circuit). Generic processors cannot provide this functionality. The ‘869 Patent specification clarifies that the claimed components, performing

the claimed functionality, are not conventional or generic.

55. Collectively, the claimed embodiments in the '869 Patent provide new solutions to problems of traditional security monitoring systems. These solutions are enabled by non-generic components functioning in a non-conventional manner.

56. The '869 Patent solves a problem with the art that is rooted in computer technology. The '869 Patent does not merely recite the performance of some business practice known from the pre-Internet world along with the requirement to perform it on the Internet.

57. Upon information and belief, Defendant has infringed and continues to infringe one or more claims, including at least Claim 1, of the '869 Patent by making, using, importing, selling, and/or offering for sale, field devices, wireless systems, circuit monitoring devices, and/or components for such systems covered by one or more claims of the '869 Patent. Defendant causes infringement by its customers and users and encourages the use of accused devices through distribution, support and customer services. Defendant has infringed and continues to infringe the '869 Patent directly in violation of 35 U.S.C. § 271.

58. Regarding Claim 1, Defendant makes, uses, sells and/or offers for sale a device for monitoring the status of a circuit based on a measurable parameter of the circuit. For example, Defendant provides an IoT Gateway Solution (SLN-IOT-GPI) for monitoring the status of a measurable parameter (such as voltage, current, resistance, conductivity and/or capacitance) of a sensor associated with the circuit. Infringing products and certain aspects of this element are illustrated in the screenshots below and/or in those provided in connection with other allegations herein.

FIGURE 1: SLN-IOT-GPI: IDEX FOR GENERAL PURPOSE IOT SYSTEMS



Source: <https://www.nxp.com/docs/en/fact-sheet/MODIOTFRAMEWORKFS.pdf>, page 2

SLN-IOT-GPI IDEX FEATURES

The SLN-IOT-GPI IDEX includes hardware and software, drivers, protocol and connectivity stacks as well as Linux BSP support.

- ▶ FCC/CE/IC certified
- ▶ Multi-protocol support for Thread, ZigBee, Wi-Fi and Ethernet
- ▶ Supports large node networks (>= 250 nodes)
- ▶ Commissioning through NFC and Smart App
- ▶ Wi-Fi and Ethernet northbound to the cloud
- ▶ Over-the-air programming via Multicast
- ▶ Smartphone app support
- ▶ i.MX6UL SOM
- ▶ Kinetis® KW22D512 or KW41Z Thread microcontroller
- ▶ JN5179 ultra low power ZigBee 3.0 and IEEE802.15.4 Module
- ▶ PN7120 NFC controller
- ▶ A70CM secure element

Source: <https://www.nxp.com/docs/en/fact-sheet/MODIOTFRAMEWORKFS.pdf>, page 2

SOFTWARE AND TOOLS TABLE

SLN-IOT-GPI IDEX SOFTWARE	DEVICE
Linux® Yocto BSP with full drivers and connectivity	i.MX6UL MCUs
MQTT client library	i.MX6UL MCUs
Thread Linux host software SDK	i.MX6UL MCUs
Gateway and end device registration with cloud	i.MX6UL MCUs
Start-up script for Wi-Fi® client service	i.MX6UL MCUs
Config file to load Wi-Fi firmware	i.MX6UL MCUs
Controls front panel LEDs	i.MX6UL MCUs
Communication bridge between cloud and end device	i.MX6UL MCUs
NFC commissioning of gateway and end devices	i.MX6UL MCUs
Thread end device controller	i.MX6UL MCUs
ZigBee end device controller	i.MX6UL MCUs
Black box Thread stack for KW41Z on gateway	Kinetis W series MCUs
Black box ZigBee stack for JN on gateway	JN MCUs
Black box stack for NFC on gateway	PN7120 NFC controller
SMARTPHONE APP SOFTWARE	
Pre-compiled Android and iOS applications to manage gateway	Smartphone
END DEVICE FIRMWARE	
MENP-KW41Z, MENP-KW22D, MENP-JN5179, MENP-JN5169, FRDM-K64F+MCR20, FRDM-KW41Z, FRDM-KW22D	Multiple

Source: <https://www.nxp.com/docs/en/fact-sheet/MODIOTFRAMEWORKFS.pdf>, page 2

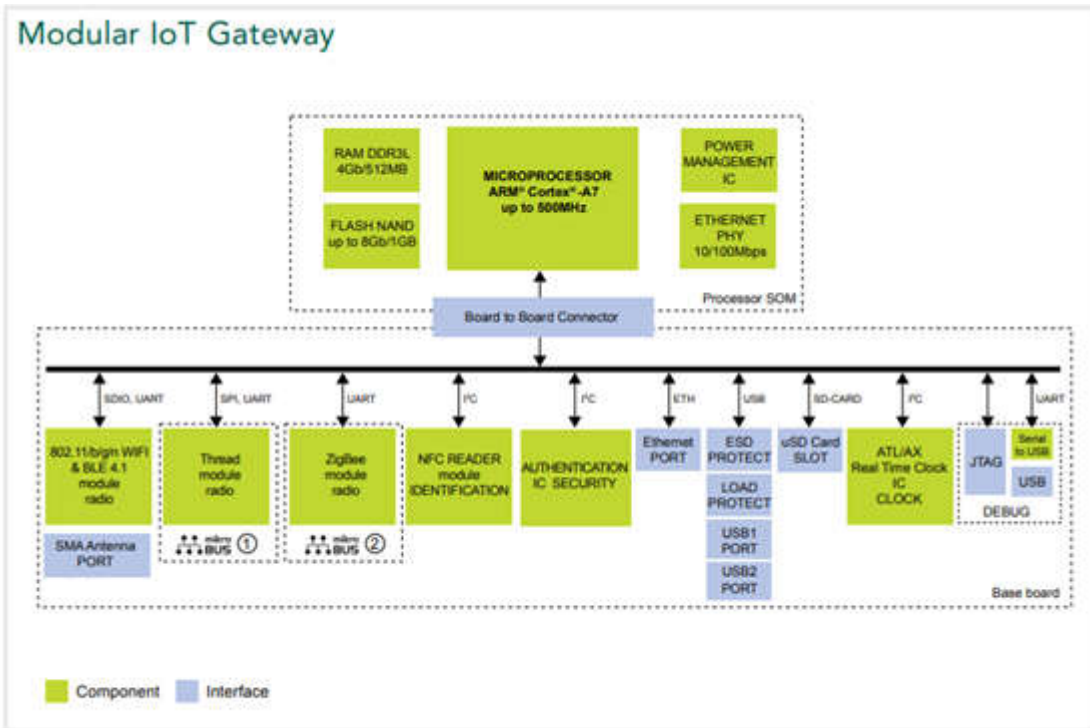

Source: <https://www.nxp.com/docs/en/fact-sheet/MODIOTFRAMEWORKFS.pdf>, page 3

IoT System Functionality Requirements

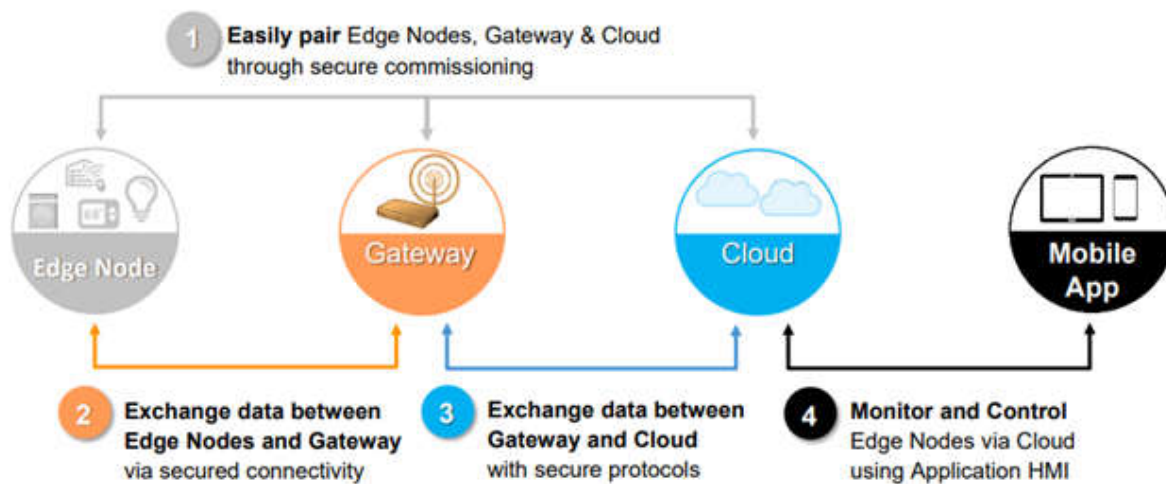

Source: <https://www.nxp.com/docs/en/supporting-information/DEV-PLATFORMS-IOT-SYSTEMS.pdf>, page 5

THERMO 4 click	Features the LM75A digital temperature sensor and a thermal watchdog with a range from -55 °C to +125 °C. The click is designed to run on either 3.3V or 5V power supply.
NFC Tag 2 click	Carries the NT3H2111 NTAG I2C energy harvesting NFC Forum Type 2 Tag from NXP. The click is designed to run on a 3.3V power supply only.
eINK click	Adapter for connecting eINK displays with very low power consumption and the ability to retain the information, even after disconnecting from the power source. Features the LM75A temperature sensor and thermal watchdog.
NFC click	Add-on board designed with the PN7120 versatile near field communications controller for contactless payment systems, electronic ticketing, smartcards, retail and advertising applications.
Diff pressure click	Diff pressure click carries the MPXV5010DP signal conditioned, temperature compensated and calibrated pressure sensor with two axial ports to accommodate industrial grade tubing
Pulse Width Modulation click	Simple solution designed with the PCA9685 controller for 16 PWM outputs through a single I2C interface. You can use it to control anything from a simple LED strip to a complex robot with a multitude of moving parts.
Altitude click	Altitude click features the pressure sensor MPL3115A2 , which provides accurate pressure/altitude (20-bit) and temperature (12-bit) data.
TILTnSHAKE click	Features the MMA8491Q 3-axis multifunctional digital accelerometer that can also be configured as a 45-degree tilt sensor.
H-Bridge Click	Features the MC34933 dual H-bridge driver to provide reasonably high current while driving the connected load with up to 7V. It is an ideal solution for light 3D printer elements driving, for precision actuators, an accurate positioning of various moving elements by using stepper motors, and similar applications.
H-Bridge 2 Click	Features the MPC17510 H-Bridge DC motor driver which implements a set of features that provide trouble-free operation of the connected motor, such as the undervoltage detection, shoot-through current protection, efficient output stage MOSFETs with low R _{DS(on)} , level shifted output for an external MOSFET control and more.

Source: <https://www.nxp.com/support/developer-resources/rapid-prototyping/docking-stations-and-click-boards:DOCKING-STATIONS-CLICK-BOARDS>

59. The infringing products provide a measurement means to measure the parameter of the circuit. For example, the IoT Gateway Solution integrates with at least one of the sensors (such pressure sensor MPL3115A2, LM75A digital temperature sensor, etc.) to measure the magnitude of the parameter (such as voltage and/or current) of the circuit associated with the sensor. Certain aspects of this element are illustrated in the screenshots below and/or those provided in connection with other allegations herein.

d Modules: Overview

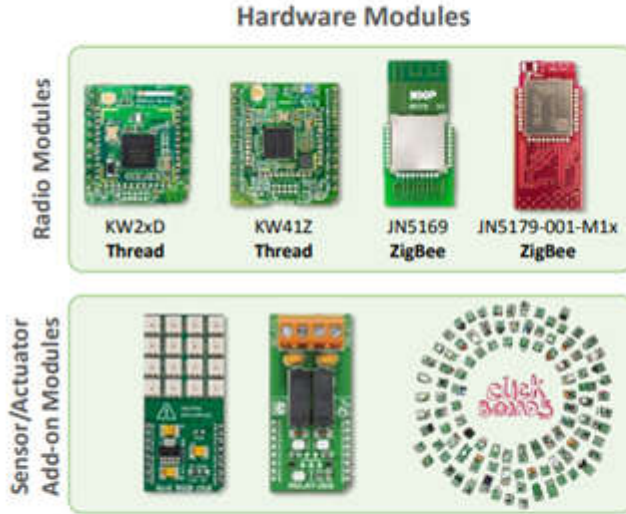

Source: <https://www.nxp.com/docs/en/supporting-information/DEV-PLATFORMS-IOT-SYSTEMS.pdf>, page 15

LM75A: Digital temperature sensor and thermal watchdog

Follow

OVERVIEW	DOCUMENTATION	TOOLS & SOFTWARE	BUY/PARAMETRICS	PACKAGE/QUALITY	TRAINING & SUPPORT
----------	---------------	------------------	-----------------	-----------------	--------------------

Jump To

- Overview & Features
- Development Boards
- Complementary Products

Overview

The LM75A is a temperature-to-digital converter using an on-chip bandgap temperature sensor and Sigma-delta A-to-D conversion technique. The device is also a thermal detector providing an overtemperature detection output. The LM75A contains a number of data registers: Configuration register (Conf) to store the device settings such as device operation mode, OS operation mode, OS polarity and OS fault queue as described in [Section 7 "Functional description"](#); temperature register (Temp) to store the digital temp reading, and set-point registers (Tos and Thyst) to store programmable overtemperature shutdown and hysteresis limits, that can be communicated by a controller via the 2-wire serial I²C-bus interface. The device also includes an open-drain output (OS) which becomes active when the temperature exceeds the programmed limits. There are three selectable logic address pins so that eight devices can be connected on the same bus without address conflict.

The LM75A can be configured for different operation conditions. It can be set in a normal mode to periodically monitor the ambient temperature, or in shutdown mode to minimize power consumption. The OS output operates

Features

- Pin-for-pin replacement for industry standard LM75 and offers improved temperature resolution of 0.125 °C and specification of a single part over power supply range from 2.8 V to 5.5 V
- Small 8-pin package types: SO8 and TSSOP8
- I²C-bus interface with up to 8 devices on the same bus
- Power supply range from 2.8 V to 5.5 V
- Temperatures range from -55 °C to +125 °C
- 11-bit ADC that offers a temperature resolution of 0.125 °C
- Temperature accuracy of:
 - +2 °C from -25 °C to +100 °C
 - +3 °C from -55 °C to +125 °C
- Programmable temperature threshold and hysteresis set points
- Supply current of 3.5 uA in shutdown mode for power conservation
- Stand-alone operation as thermostat at power-up

Source: <https://www.nxp.com/products/sensors/other-sensors/ic-temperature-sensors/digital-temperature-sensor-and-thermal-watchdog:LM75A>

MPL3115A2: 20 to 110 kPa, Absolute Digital Pressure Sensor

Follow 

OVERVIEW	DOCUMENTATION	TOOLS & SOFTWARE	BUY/PARAMETRICS	PACKAGE/QUALITY	TRAINING & SUPPORT
----------	---------------	------------------	-----------------	-----------------	--------------------

Jump To

Overview & Features
 Development Boards
 Target Applications
 Complementary Products

Overview

The MPL3115A2 is a compact piezoresistive absolute pressure sensor with an I2C interface. MPL3115 has a wide operating range of 20 kPa to 110 kPa, a range that covers all surface elevations on Earth. The fully internally compensated MEMS in conjunction with an embedded high resolution 24-bit equivalent ADC provide accurate pressure [Pascals] /altitude [meters] and temperature [degrees Celsius] data. The internal processing in MPL3115A2 removes compensation and unit conversion load from the system MCU, simplifying system design.

MPL3115A2's advanced ASIC has multiple user programmable modes such as power saving, interrupt and autonomous data acquisition modes, including programmed acquisition cycle timing, and poll-only modes. Typical active supply current is 40 uA per measurement-second for a stable 10 cm output resolution.

Features

- Calibrated range: 50 kPa to 110 kPa absolute pressure
- Operating range: 20 kPa to 110 kPa absolute pressure
- I2C digital output interface (up to 400 kHz)
- Fully compensated internally
- Direct reading:
 - Pressure: 20-bit measurement [Pascals]
 - Altitude: 20-bit measurement [meters]
 - Temperature: 12-bit measurement [degrees Celsius]
- Programmable Interrupts
- Autonomous Data Acquisition:
 - Embedded 32-Sample FIFO
 - Data logging up to 12 days using the FIFO
 - 1 second to 9 hour data acquisition rate
- 1.95 V to 3.6 V Supply Voltage, internally regulated
- 1.6 V to 3.6 V Digital interface Supply Voltage
- Operating temperature from -40 °C to +85 °C.

Source: <https://www.nxp.com/products/sensors/pressure-sensors/barometric-pressure-15-to-115-kpa/20-to-110-kpa-absolute-digital-pressure-sensor:MPL3115A2>

60. The infringing products a comparison means to compare the measured parameter to a plurality of threshold values and to assign a status based on a result of the comparison. For example, the IoT Gateway Solution integrates with Modular IoT Gateway and at least one of the sensors (such as pressure sensor MPL3115A2, LM75A digital temperature sensor, etc.) via a wireless communication network and compares the measured parameter with a threshold value to generate a status signal (such as alert, notification and/or alarm). Certain aspects of this element are illustrated in the screenshots below and/or those provided in connection with other allegations herein.

Modular IoT Gateway: Hardware Block Diagram

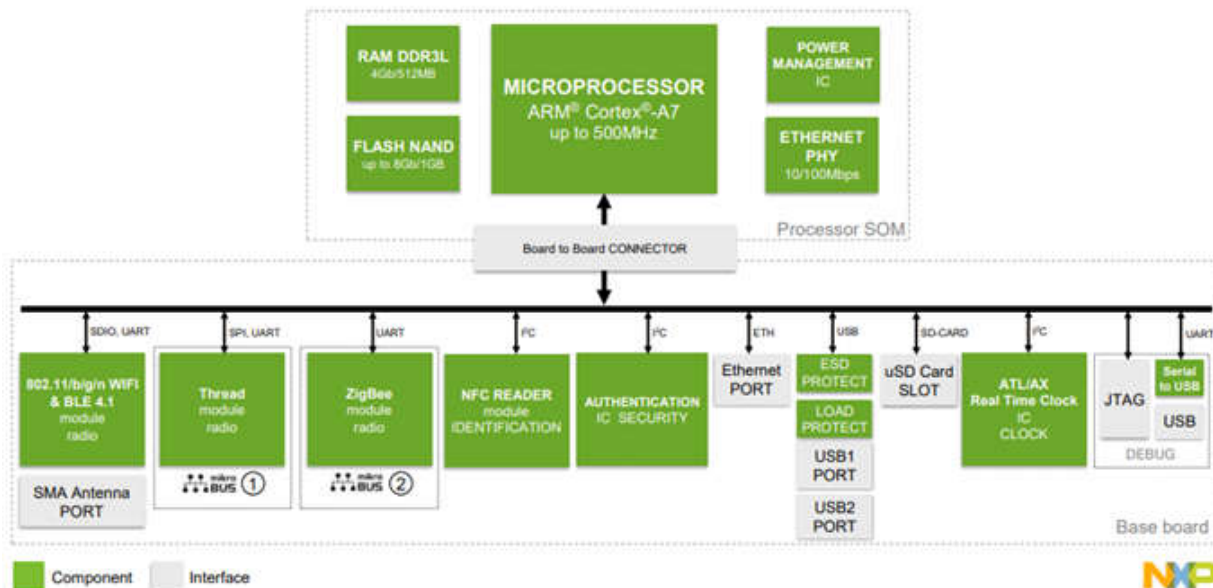

Source: <https://www.nxp.com/docs/en/supporting-information/DEV-PLATFORMS-IOT-SYSTEMS.pdf>, page 12

IDEx for General Purpose IoT Systems: Functional Specifications

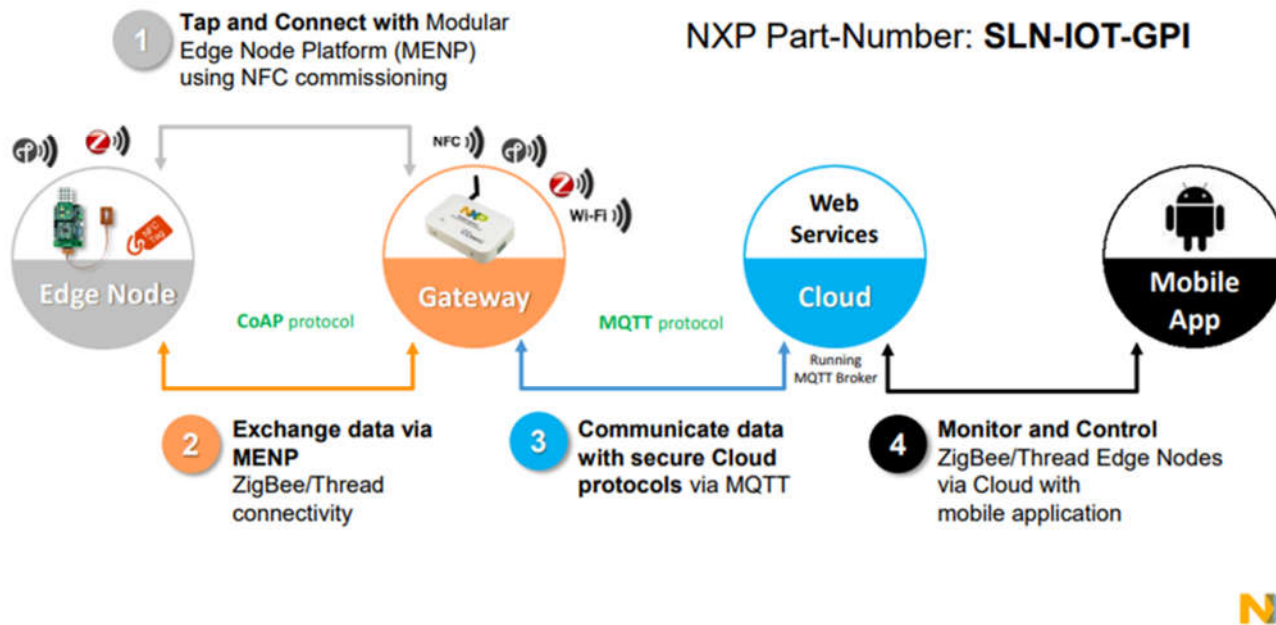

61. The infringing products provide a transmission means to communicate the status over a network and to limit the communicated status to only digital bits indicating the status and being sufficient to describe the status. For example, the IoT Gateway Solution comprises a

communication module (“transmission means”) for at least one of the sensors (such as pressure sensor MPL3115A2, LM75A digital temperature sensor, etc.) to transmit the status signal (such as alert, notification and/or alarm) via a wireless network (such as Wi-Fi/BT/BLE 4.1 and/or ZigBee) to a Modular IoT Gateway and/or a mobile computing device (“display”). Certain aspects of this element are illustrated in the screenshots below and/or those provided in connection with other allegations herein.

Modular Edge Node Platform

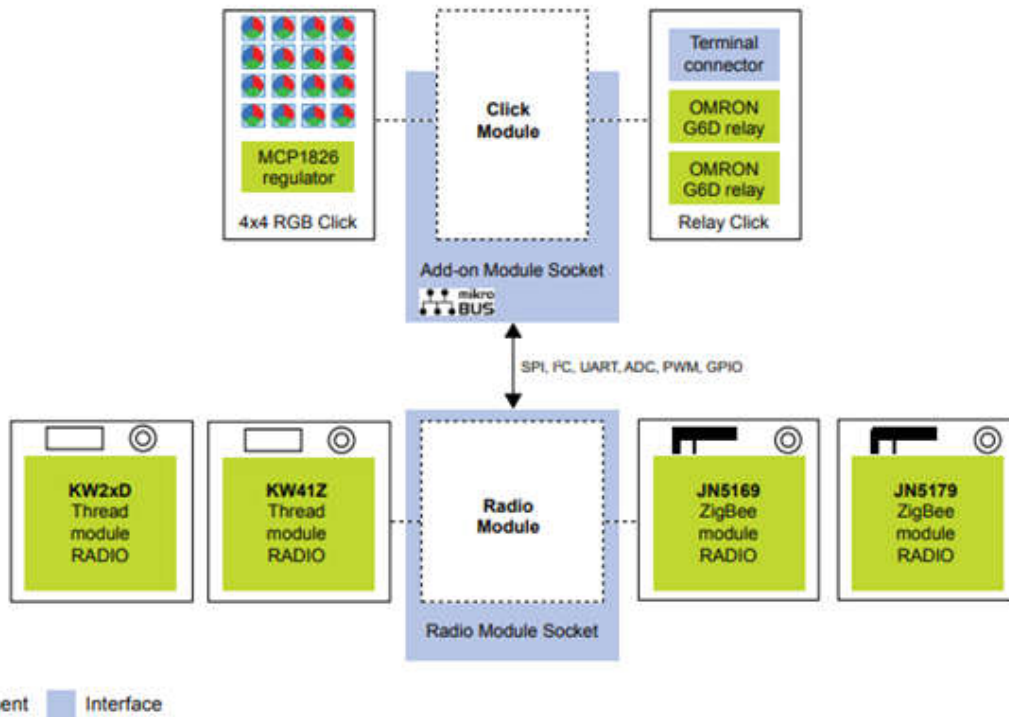

Source: <https://www.nxp.com/docs/en/fact-sheet/MODIOTFRAMEWORKFS.pdf>, page 3

Complexity of IoT System Development

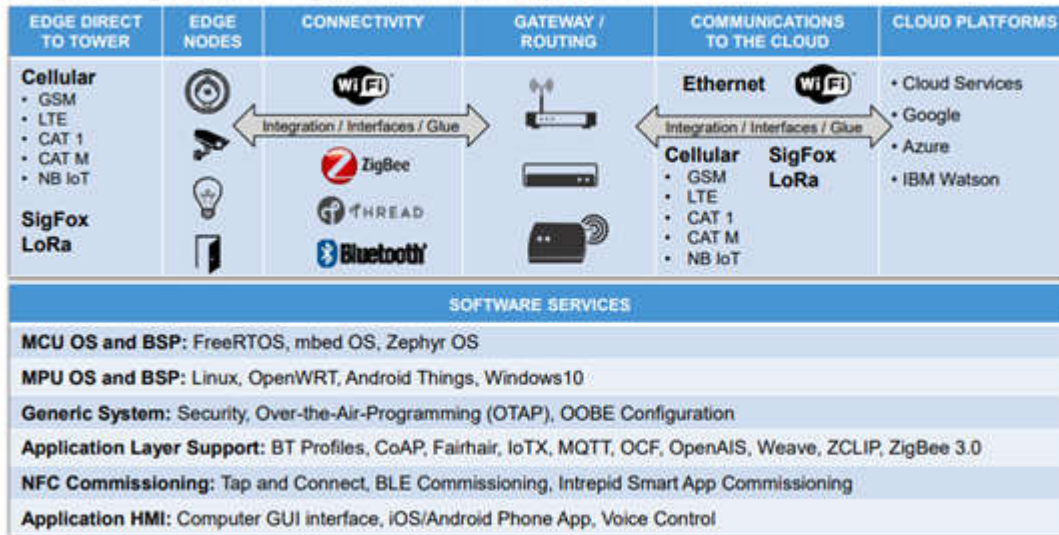

Fragmented market with thousands of use case combinations



Source: <https://www.nxp.com/docs/en/supporting-information/DEV-PLATFORMS-IOT-SYSTEMS.pdf>, page 4

Integrated Development Experience (IDEx) for General Purpose IoT Systems

- Includes Pre-Configured Modular IoT Gateway and Modular Edge Node Platform



- Modular IoT Gateway**
- Modular IoT Gateway Base board
 - i.MX6UL SOM
 - Wi-Fi/BT/BLE 4.1
 - Thread/BLE Radio
 - ZigBee Radio
 - NFC Reader
 - A7x Secure Element



- Modular Edge Node Platform (MENP)**
- Simple Edge Node Base board
 - ZigBee Radio
 - Thread/BLE Radio
 - NFC Tag
 - RGB Click Module

- Includes Connectivity and Security Software

- Modular IoT Gateway**
- Linux OS and component drivers (BSP)
 - Connectivity and Cloud Protocols
 - NFC Connectivity and Cloud commissioning
 - Secure Over-The-Air Programming
 - Application software

- Modular Edge Node Platform (MENP)**
- FreeRTOS with SDK peripheral drivers
 - Connectivity Stacks (ZigBee, Thread)
 - NFC Connectivity commissioning

Shipping TODAY as NXP Part-Number: SLN-IOT-GPI



Source: <https://www.nxp.com/docs/en/supporting-information/DEV-PLATFORMS-IOT-SYSTEMS.pdf>, page 10

62. The infringing products provide a transmission means wherein the status communication is transmitted over the network to an output means configured to present an indication of the assigned status. For example, the IoT Gateway Solution provides a mobile application support to display an indication (such as alarm, notification and/or alerts) of at least

one of the coupled sensors (such as pressure sensor MPL3115A2, LM75A digital temperature sensor, etc.) based on the signal assigned status on a computing device (such as smartphone, tablet and/or computer). Certain aspects of this element are illustrated in the screenshots provided in connection with other allegations herein.

63. Defendant's actions complained of herein will continue unless Defendant is enjoined by this court.

64. Defendant's actions complained of herein are causing irreparable harm and monetary damage to Plaintiff and will continue to do so unless and until Defendant is enjoined and restrained by this Court.

65. Plaintiff is in compliance with 35 U.S.C. § 287.

COUNT IV
(INFRINGEMENT OF UNITED STATES PATENT NO. 8,912,893)

66. Plaintiff incorporates paragraphs 1 through 65 herein by reference.

67. This cause of action arises under the patent laws of the United States and, in particular, under 35 U.S.C. §§ 271, et seq.

68. Plaintiff is the owner by assignment of the '893 Patent with sole rights to enforce the '893 Patent and sue infringers.

69. A copy of the '893 Patent, titled "Circuit Monitoring Device," is attached hereto as Exhibit D.

70. The '893 Patent is valid, enforceable, and was duly issued in full compliance with Title 35 of the United States Code.

71. The claims of the '893 recite subject matter that is similar to that recited in the claims of the '683 Patent (discussed above in connection with Count I). The specification of the '893 Patent discloses problems of prior systems and non-generic solutions in a manner similar

to the specification of the '683 Patent (discussed above in connection with Count I).

72. The components recited in the claims (such as in claim 1 for example) are configured, such that they operate in a non-conventional manner.

73. The components recited in the claims (such as in claim 1 for example) are configured so as to allow a user to set customized ranges of values to be set as parameters of end-of-line modules (i.e., parameters of a circuit). Generic processors cannot provide this functionality. The '893 Patent specification clarifies that the claimed components, performing the claimed functionality, are not conventional or generic.

74. Collectively, the claimed embodiments in the '893 Patent provide new solutions to problems of traditional security monitoring systems. These solutions are enabled by non-generic components functioning in a non-conventional manner.

75. The '893 Patent solves a problem with the art that is rooted in computer technology. The '893 Patent does not merely recite the performance of some business practice known from the pre-Internet world along with the requirement to perform it on the Internet.

76. Upon information and belief, Defendant has infringed and continues to infringe one or more claims, including at least Claim 1, of the '893 Patent by making, using, importing, selling, and/or offering for sale, field devices, wireless systems, circuit monitoring devices, and/or components for such systems covered by one or more claims of the '893 Patent. Defendant causes infringement by its customers and users and encourages the use of accused devices through distribution, support and customer services. Defendant has infringed and continues to infringe the '893 Patent directly in violation of 35 U.S.C. § 271.

77. Regarding Claim 1, Defendant makes, uses, sells and/or offers for a circuit monitoring device. For example, Defendant provides an IoT Gateway Solution (SLN-IOT-GPI)

for monitoring measurable parameter (such as voltage, current, resistance, conductivity and/or capacitance) of a sensor associated with the circuit. Infringing products and certain aspects of this element are illustrated in the screenshots below and/or in those provided in connection with other allegations herein.

FIGURE 1: SLN-IOT-GPI: IDEX FOR GENERAL PURPOSE IOT SYSTEMS



Source: <https://www.nxp.com/docs/en/fact-sheet/MODIOTFRAMEWORKFS.pdf>, page 2

SLN-IOT-GPI IDEX FEATURES

The SLN-IOT-GPI IDEX includes hardware and software, drivers, protocol and connectivity stacks as well as Linux BSP support.

- ▶ FCC/CE/IC certified
- ▶ Multi-protocol support for Thread, ZigBee, Wi-Fi and Ethernet
- ▶ Supports large node networks (>= 250 nodes)
- ▶ Commissioning through NFC and Smart App
- ▶ Wi-Fi and Ethernet northbound to the cloud
- ▶ Over-the-air programming via Multicast
- ▶ Smartphone app support
- ▶ i.MX6UL SOM
- ▶ Kinetis® KW22D512 or KW41Z Thread microcontroller
- ▶ JN5179 ultra low power ZigBee 3.0 and IEEE802.15.4 Module
- ▶ PN7120 NFC controller
- ▶ A70CM secure element

Source: <https://www.nxp.com/docs/en/fact-sheet/MODIOTFRAMEWORKFS.pdf>, page 2

SOFTWARE AND TOOLS TABLE

SLN-IOT-GPI IDEX SOFTWARE	DEVICE
Linux® Yocto BSP with full drivers and connectivity	i.MX6UL MCUs
MQTT client library	i.MX6UL MCUs
Thread Linux host software SDK	i.MX6UL MCUs
Gateway and end device registration with cloud	i.MX6UL MCUs
Start-up script for Wi-Fi® client service	i.MX6UL MCUs
Config file to load Wi-Fi firmware	i.MX6UL MCUs
Controls front panel LEDs	i.MX6UL MCUs
Communication bridge between cloud and end device	i.MX6UL MCUs
NFC commissioning of gateway and end devices	i.MX6UL MCUs
Thread end device controller	i.MX6UL MCUs
ZigBee end device controller	i.MX6UL MCUs
Black box Thread stack for KW41Z on gateway	Kinetis W series MCUs
Black box ZigBee stack for JN on gateway	JN MCUs
Black box stack for NFC on gateway	PN7120 NFC controller
SMARTPHONE APP SOFTWARE	
Pre-compiled Android and iOS applications to manage gateway	Smartphone
END DEVICE FIRMWARE	
MENP-KW41Z, MENP-KW22D, MENP-JNS179, MENP-JNS169, FRDM-K64F+MCR20, FRDM-KW41Z, FRDM-KW22D	Multiple

Source: <https://www.nxp.com/docs/en/fact-sheet/MODIOTFRAMEWORKFS.pdf>, page 2

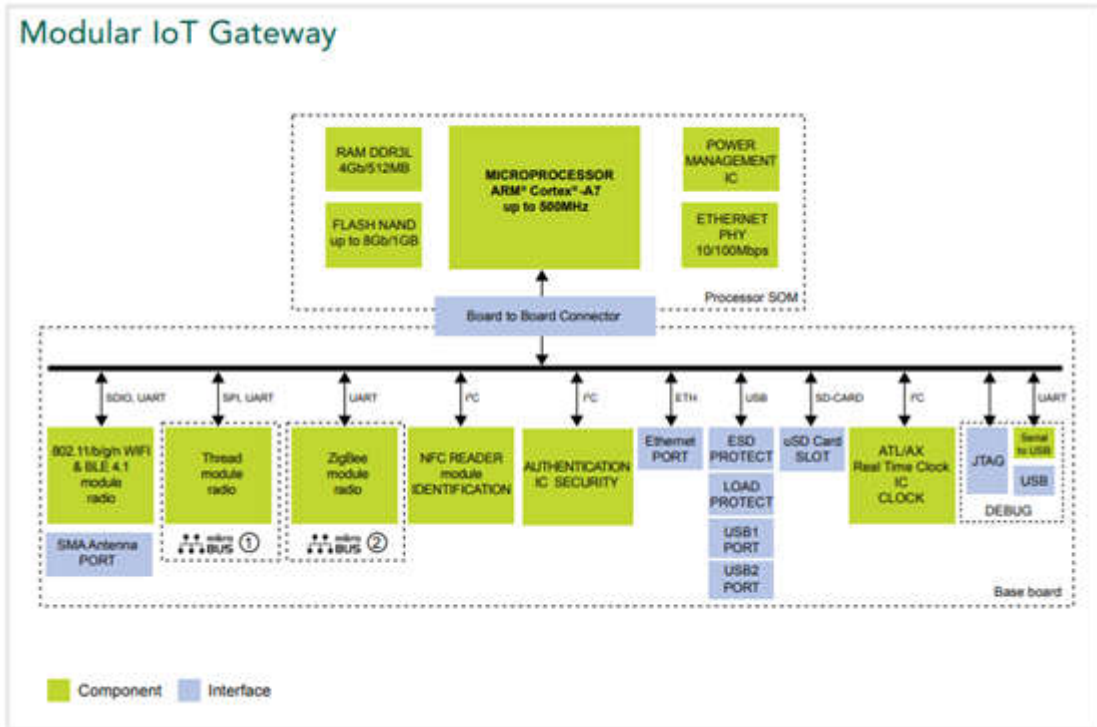

Source: <https://www.nxp.com/docs/en/fact-sheet/MODIOTFRAMEWORKFS.pdf>, page 3

IoT System Functionality Requirements

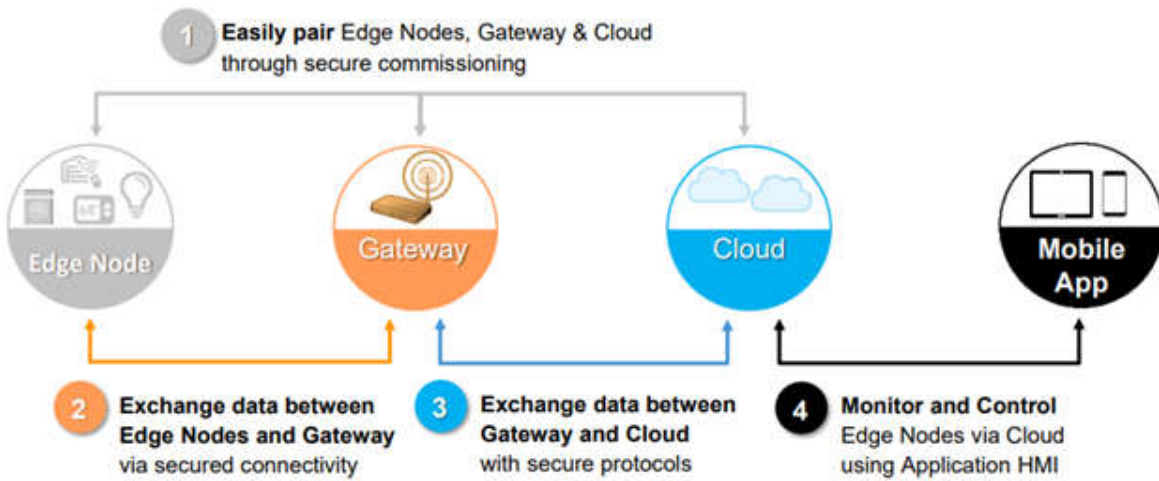

Source: <https://www.nxp.com/docs/en/supporting-information/DEV-PLATFORMS-IOT-SYSTEMS.pdf>, page 5

THERMO 4 click	Features the LM75A digital temperature sensor and a thermal watchdog with a range from -55 °C to +125 °C. The click is designed to run on either 3.3V or 5V power supply.
NFC Tag 2 click	Carries the NT3H2111 NTAG I2C energy harvesting NFC Forum Type 2 Tag from NXP. The click is designed to run on a 3.3V power supply only.
eINK click	Adapter for connecting eINK displays with very low power consumption and the ability to retain the information, even after disconnecting from the power source. Features the LM75A temperature sensor and thermal watchdog.
NFC click	Add-on board designed with the PN7120 versatile near field communications controller for contactless payment systems, electronic ticketing, smartcards, retail and advertising applications.
Diff pressure click	Diff pressure click carries the MPXV5010DP signal conditioned, temperature compensated and calibrated pressure sensor with two axial ports to accommodate industrial grade tubing.
Pulse Width Modulation click	Simple solution designed with the PCA9685 controller for 16 PWM outputs through a single I2C interface. You can use it to control anything from a simple LED strip to a complex robot with a multitude of moving parts.
Altitude click	Altitude click features the pressure sensor MPL3115A2 , which provides accurate pressure/altitude (20-bit) and temperature (12-bit) data.
TILTnSHAKE click	Features the MMA8491Q 3-axis multifunctional digital accelerometer that can also be configured as a 45-degree tilt sensor.
H-Bridge Click	Features the MC34933 dual H-bridge driver to provide reasonably high current while driving the connected load with up to 7V. It is an ideal solution for light 3D printer elements driving, for precision actuators, an accurate positioning of various moving elements by using stepper motors, and similar applications.
H-Bridge 2 Click	Features the MPC17510 H-Bridge DC motor driver which implements a set of features that provide trouble-free operation of the connected motor, such as the undervoltage detection, shoot-through current protection, efficient output stage MOSFETs with low RDSON, level shifted output for an external MOSFET control and more.

Source: <https://www.nxp.com/support/developer-resources/rapid-prototyping/docking-stations-and-click-boards:DOCKING-STATIONS-CLICK-BOARDS>

78. The infringing products provide one or more processors, each having a memory and an input electrically coupled to a circuit which is configured to receive a measured electrical parameter of the circuit, and modules comprising software to configure the one or more processors. For example, the IoT Gateway Solution comprises of one or more processors, each having a memory and an input (such as temperature and/or pressure) electrically coupled to a sensor (including but not limited to temperature sensor and/or pressure sensor) which is configured to receive the measured electrical parameter (such as voltage, inductance, current and/or resistance) of the circuit. Further, the IoT Gateway Solution also comprises software to configure one or more processors and integrate with a mobile computing device to generate alerts, notifications and/or alarms via a mobile app support. Certain aspects of this element are illustrated in the screenshots below and/or those provided in connection with other allegations herein.

LM75A: Digital temperature sensor and thermal watchdog

[Follow](#)  

OVERVIEW

DOCUMENTATION

TOOLS & SOFTWARE

BUY/PARAMETRICS

PACKAGE/QUALITY

TRAINING & SUPPORT

Jump To

Overview & Features
Development Boards
Complementary Products

Overview

The LM75A is a temperature-to-digital converter using an on-chip bandgap temperature sensor and Sigma-delta A-to-D conversion technique. The device is also a thermal detector providing an overtemperature detection output. The LM75A contains a number of data registers: Configuration register (Conf) to store the device settings such as device operation mode, OS operation mode, OS polarity and OS fault queue as described in [Section 7 "Functional description"](#), temperature register (Temp) to store the digital temp reading, and set-point registers (Tos and Thyst) to store programmable overtemperature shutdown and hysteresis limits, that can be communicated by a controller via the 2-wire serial I²C-bus interface. The device also includes an open-drain output (OS) which becomes active when the temperature exceeds the programmed limits. There are three selectable logic address pins so that eight devices can be connected on the same bus without address conflict.

The LM75A can be configured for different operation conditions. It can be set in a normal mode to periodically monitor the ambient temperature, or in shutdown mode to minimize power consumption. The OS output operates

Features

- Pin-for-pin replacement for industry standard LM75 and offers improved temperature resolution of 0.125 °C and specification of a single part over power supply range from 2.8 V to 5.5 V
- Small 8-pin package types: SO8 and TSSOP8
- I²C-bus interface with up to 8 devices on the same bus
- Power supply range from 2.8 V to 5.5 V
- Temperatures range from -55 °C to +125 °C
- 11-bit ADC that offers a temperature resolution of 0.125 °C
- Temperature accuracy of:
 - +2 °C from -25 °C to +100 °C
 - +3 °C from -55 °C to +125 °C
- Programmable temperature threshold and hysteresis set points
- Supply current of 3.5 uA in shutdown mode for power conservation
- Stand-alone operation as thermostat at power-up

Source: <https://www.nxp.com/products/sensors/other-sensors/ic-temperature-sensors/digital-temperature-sensor-and-thermal-watchdog:LM75A>

MPL3115A2: 20 to 110 kPa, Absolute Digital Pressure Sensor

[Follow](#) 

OVERVIEW

DOCUMENTATION

TOOLS & SOFTWARE

BUY/PARAMETRICS

PACKAGE/QUALITY

TRAINING & SUPPORT

Jump To

Overview & Features
Development Boards
Target Applications
Complementary Products

Overview

The MPL3115A2 is a compact piezoresistive absolute pressure sensor with an I²C interface. MPL3115 has a wide operating range of 20 kPa to 110 kPa, a range that covers all surface elevations on Earth. The fully internally compensated MEMS in conjunction with an embedded high resolution 24-bit equivalent ADC provide accurate pressure [Pascals] /altitude [meters] and temperature [degrees Celsius] data. The internal processing in MPL3115A2 removes compensation and unit conversion load from the system MCU, simplifying system design.

MPL3115A2's advanced ASIC has multiple user programmable modes such as power saving, interrupt and autonomous data acquisition modes, including programmed acquisition cycle timing, and poll-only modes. Typical active supply current is 40 uA per measurement-second for a stable 10 cm output resolution.

Features

- Calibrated range: 50 kPa to 110 kPa absolute pressure
- Operating range: 20 kPa to 110 kPa absolute pressure
- I²C digital output interface (up to 400 kHz)
- Fully compensated internally
- Direct reading:
 - Pressure: 20-bit measurement [Pascals]
 - Altitude: 20-bit measurement [meters]
 - Temperature: 12-bit measurement [degrees Celsius]
- Programmable Interrupts
- Autonomous Data Acquisition:
 - Embedded 32-Sample FIFO
 - Data logging up to 12 days using the FIFO
 - 1 second to 9 hour data acquisition rate
- 1.95 V to 3.6 V Supply Voltage, internally regulated
- 1.6 V to 3.6 V Digital Interface Supply Voltage
- Operating temperature from -40 °C to +85 °C

Source: <https://www.nxp.com/products/sensors/pressure-sensors/barometric-pressure-15-to-115-kpa/20-to-110-kpa-absolute-digital-pressure-sensor:MPL3115A2>

d Modules: Overview

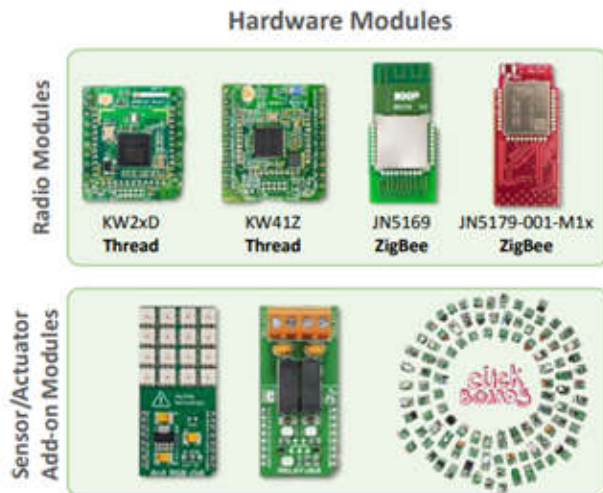

Source: <https://www.nxp.com/docs/en/supporting-information/DEV-PLATFORMS-IOT-SYSTEMS.pdf>, page 15

Modular IoT Gateway: Summary

Fastest Time to Market

Modular solution reduces development time for Thread and ZigBee Gateway/Border Router applications

Path to Manufacturing

BOM, design files and software source code limit risks with wireless connectivity

Optimized Hardware Design

Includes best practices for IoT Gateway application design

Robust Software

Includes everything from embedded drivers to cloud connectivity - optimized and easy to use

NXP Hardware, Software & Services

Drivers, protocol stacks, Linux BSP support

Target Segments/Applications

- Commercial Building/Lighting
- Smart Home
- Low Power WAN



Key Features

Performance: **ARM Cortex®-A7 @ 696MHz**
 Local Connectivity in Large Networks 255+ nodes: **ZigBee, Thread**
 Cloud Connectivity: **Wi-Fi and Ethernet**
 Authentication: **Secure Element**
 Set up: **NFC Commissioning w/Smart App**
 Update: **Over the Air Programming via Multicast**
 Certifications: **FCC/CE/IC**

Design Resources

Design files: Schematic, Layout, Bill of Material
Application program (Image + Source code)
Android Application (App + Source code)
Professional Support and Services

Software Enablement

(Open source and free)
 UBOOT, Linux BSP
 Board Component Drivers
 Protocol Stack



Source: <https://www.nxp.com/docs/en/supporting-information/DEV-PLATFORMS-IOT-SYSTEMS.pdf>, page 12

Modular IoT Gateway: *Hardware Block Diagram*

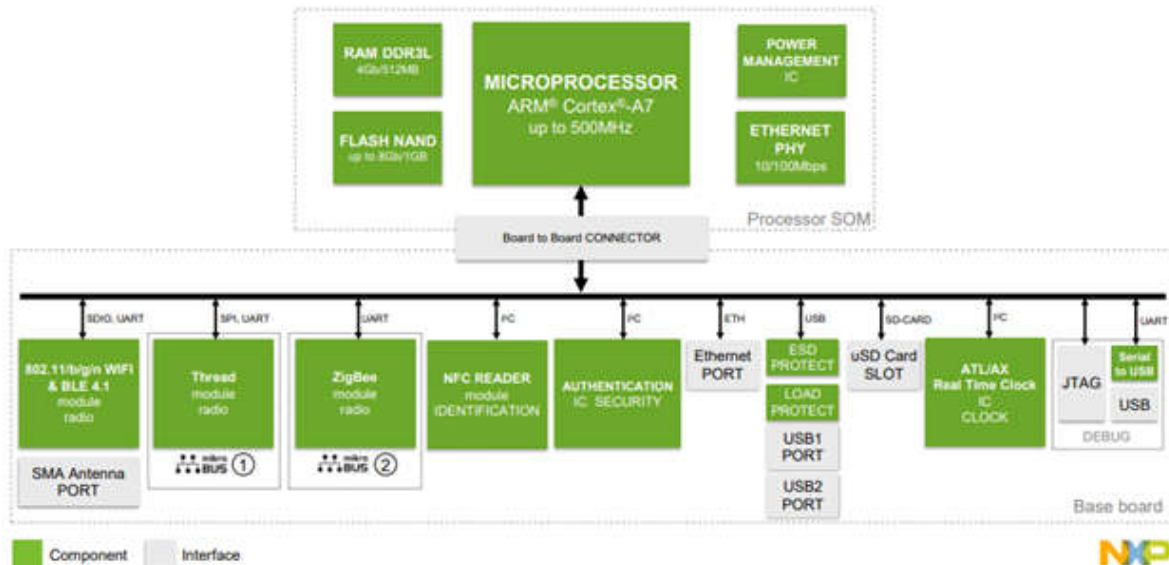

Source: <https://www.nxp.com/docs/en/supporting-information/DEV-PLATFORMS-IOT-SYSTEMS.pdf>, page 13

79. The infringing products a comparison module configured to compare a digital value, which corresponds to a magnitude of the measured electrical parameter, to a plurality of threshold values stored in the memory, wherein the plurality of threshold values define a respective plurality of ranges of digital values, each range corresponding to one of a plurality of conditions of the circuit including a normal condition and at least one alarm condition. For example, the IoT Gateway Solution comprises a comparison module that integrates Modular IoT Gateway and at least one of the sensors (such as pressure sensor MPL3115A2, LM75A digital temperature sensor, etc.) via a wireless communication network and compares the digital value (a voltage and/or current indicative count value i.e. low or high) corresponding to a magnitude of measured electrical parameter (such as voltage, current, inductance and/or resistance) with a plurality of threshold values (such as normal value condition and/or alarm value condition (alert, notification and/or alarm)) stored in memory. Certain aspects of this element are illustrated in the screenshots provided in connection with other allegations herein.

80. The infringing products provide a comparison module to assign a status based on the digital value being within a particular range defined by one or more of the plurality of threshold values. For example, the IoT Gateway Solution comprising the sensor assigns a status (such as alarm, notification and/or alerts) based on the digital value (such as voltage and/or current indicative count value i.e. low or high) which is within a particular range defined by one or more of the plurality of threshold values (such as normal value condition and/or alarm value condition). Certain aspects of this element are illustrated in the screenshots provided in connection with other allegations herein.

81. The infringing products provide a communication module configured to generate a status signal including at least the assigned status. For example, the IoT Gateway Solution integrates with Modular IoT Gateway and at least one of the sensors (such as pressure sensor MPL3115A2, LM75A digital temperature sensor, etc.) via a wireless communication network which is configured to generate a status signal (such as notification, alert and/or alarm) representative of the measured electrical parameter associated with the sensor. Certain aspects of this element are illustrated in the screenshots provided in connection with other allegations herein.

82. The infringing products provide a transmitter configured to transmit the status signal to a centralized system over a network for output, by the centralized system, of the status. For example, the IoT Gateway Solution comprises a communication module (“transmitter”) for at least one of the sensors (such as pressure sensor MPL3115A2, LM75A digital temperature sensor, etc.) to a Modular IoT Gateway (“centralized system”) via a wireless network (such as Wi-Fi/BT/BLE 4.1 and/or ZigBee). Further, the Modular IoT Gateway transmits a display indication (such as alarm, notification and/or alerts) of status signal to a mobile computing device

via a mobile application support. Certain aspects of this element are illustrated in the screenshots provided in connection with other allegations herein.

83. Defendant's actions complained of herein will continue unless Defendant is enjoined by this court.

84. Defendant's actions complained of herein are causing irreparable harm and monetary damage to Plaintiff and will continue to do so unless and until Defendant is enjoined and restrained by this Court.

85. Plaintiff is in compliance with 35 U.S.C. § 287.

PRAYER FOR RELIEF

WHEREFORE, Plaintiff asks the Court to:

- (a) Enter judgment for Plaintiff on this Complaint on all causes of action asserted herein;
- (b) Award Plaintiff past and future damages, costs, and expenses resulting from Defendant's infringement in accordance with 35 U.S.C. § 284;
- (c) Award Plaintiff pre-judgment and post-judgment interest and costs; and
- (d) Award Plaintiff such further relief to which the Court finds Plaintiff entitled under law or equity.

Dated: April 24, 2019

Respectfully submitted,

/s/ Jay Johnson

JAY JOHNSON

State Bar No. 24067322

D. BRADLEY KIZZIA

State Bar No. 11547550

KIZZIA JOHNSON, PLLC

1910 Pacific Ave., Suite 13000

Dallas, Texas 75201

(214) 451-0164

Fax: (214) 451-0165
jay@kjpllc.com
bkizzia@kjpllc.com

ATTORNEYS FOR PLAINTIFF

EXHIBIT A

A

EXHIBIT B

EXHIBIT C

EXHIBIT D