

**IN THE UNITED STATES DISTRICT COURT
FOR THE EASTERN DISTRICT OF TEXAS
MARSHALL DIVISION**

AMERICAN GNC CORPORATION,

Plaintiff,

v.

TOYOTA MOTOR CORPORATION,
TOYOTA MOTOR NORTH AMERICA,
INC., TOYOTA MOTOR SALES, U.S.A.,
INC., and TOYOTA MOTOR
ENGINEERING & MANUFACTURING
NORTH AMERICA, INC.,

Defendants.

Civil Action No.

JURY TRIAL DEMANDED

COMPLAINT

Plaintiff American GNC Corporation files this Complaint for patent infringement under the patent laws of the United States, Title 35 of the United States Code against Defendants Toyota Motor Corporation, Toyota Motor North America, Inc., Toyota Motor Sales, U.S.A., Inc., and Toyota Motor Engineering & Manufacturing North America, Inc., (collectively “Toyota”) and alleges as follows:

PARTIES

1. Plaintiff American GNC Corporation (“AGNC”) is a California corporation with its principal place of business at 888 Easy Street, Simi Valley, California 93065 that specializes in inventing and applying advanced and innovative technologies to contemporary problems within

the fields of Guidance, Navigation, Control and Communications (GNCC), Inertial Sensors, Health Monitoring, Intelligent Processing, and Autonomous Robotics.

2. Defendant Toyota Motor Corporation is a corporation duly organized and existing under the laws of Japan, with its principal place of business at 1 Toyota-cho, Toyota city, Aichi Prefecture 471-8571, Japan. On information and belief, Toyota Motor Corporation can be served with process at that address.

3. Defendant Toyota Motor North America, Inc. is a corporation with its principal place of business at 6565 Headquarters Drive, Plano, Texas 75024. Toyota Motor North America can be served with process through its registered agent, C T Corporation System, at 1999 Bryan Street, Suite 900 Dallas, Texas 75201.

4. Toyota Motor Sales, U.S.A., Inc. is a corporation with a place of business located at 6565 Headquarters Drive, Plano, Texas 75024. Toyota Motor Sales, U.S.A., Inc., can be served with process through its registered agent, C T Corporation System, at 1999 Bryan Street, Suite 900 Dallas, Texas 75201.

5. Toyota Motor Engineering & Manufacturing North America, Inc. is a corporation with a place of business located at 6565 Headquarters Drive, Plano, Texas 75024. Toyota Motor Engineering & Manufacturing North America, Inc. can be served with process through its registered agent, C T Corporation System, at 1999 Bryan Street, Suite 900 Dallas, Texas 75201.

6. Toyota made, used, imported, sold, and/or offered for sale Toyota, Lexus, and Scion branded vehicles.

7. Toyota makes, uses, imports, sells, and/or offers for sale Toyota and Lexus branded vehicles.

8. Toyota makes, uses, imports, sells and/or offers for sale automobiles containing a yaw rate sensor.

9. Toyota is ranked by independent industry analysts as the second-largest supplier of automobiles in the U.S.

10. Approximately 29% of global Toyota sales take place within the United States.

JURISDICTION AND VENUE

11. This is a civil action for patent infringement arising under the Patent Laws of the United States, 35 U.S.C. § 1, *et seq.*, and more particularly 35 U.S.C. § 271.

12. This Court has jurisdiction over the subject matter of this action under 28 U.S.C. §§ 1331 and 1338(a).

13. Each Toyota Defendant is subject to this Court's general personal jurisdiction pursuant to due process and/or the Texas Long Arm Statute, Tex. Civ. Prac. & Rem. Code § 17.042, due at least to its substantial business conducted in this District, including: (i) having conducted business in this District and the State of Texas through its multiple offices; (ii) having solicited business in the State of Texas, transacted business within the State of Texas and derived financial benefit from residents of the State of Texas in this District, including benefits directly related to the instant patent infringement causes of action set forth herein by selling Toyota automobiles in Texas and this District; (iii) having placed its products and services into the stream of commerce throughout the United States and having been actively engaged in transacting business in Texas and in this District, and (iv) having committed the complained of tortious acts in Texas and in this District.

14. Toyota, directly and/or through subsidiaries and agents (including distributors, retailers, and others), makes, imports, distributes, offers for sale, sells, uses, and advertises

(including offering products and services through its website, <https://www.toyota.com>, as well as other retailers) its products and/or services in the United States, the State of Texas, and the Eastern District of Texas.

15. Toyota, directly and/or through its subsidiaries and agents (including distributors, retailers, and others), has purposefully and voluntarily placed one or more of its infringing products, as described below, into the stream of commerce with the expectation that they will be purchased and used by consumers in the Eastern District of Texas. These infringing products and/or services have been and continue to be purchased and used by consumers in the Eastern District of Texas. Toyota has committed acts of patent infringement within the State of Texas and, more particularly, within the Eastern District of Texas.

16. In addition, Defendant Toyota Motor North America, Inc. is registered to do business in the State of Texas and headquartered in this District in Plano, Texas. Defendants Toyota Motor Sales, U.S.A., Inc. and Toyota Motor Engineering & Manufacturing North American, Inc. are headquartered in Plano, Texas as well.

17. This Court's exercise of personal jurisdiction over Toyota is consistent with the Texas long-arm statute, Tex. Civ. Prac. & Rem. Code § 17.042, and traditional notions of fair play and substantial justice.

18. Toyota is also subject to this Court's specific personal jurisdiction, because the present dispute arises from, and is related to, Toyota's activities in Texas and in this District, as described above. These activities include Toyota soliciting business from, and transacting business with customers in the State of Texas and deriving financial benefit from transactions with customers in the State of Texas in this District, including sales of Toyota automobiles. Toyota, directly and/or through subsidiaries and agents (including distributors, retailers, and others),

makes, imports, distributes, offers for sale, sells, uses, and advertises (including offering products and services through its website <https://www.toyota.com> as well as other retailers) its products and/or services in the United States, the State of Texas and the Eastern District of Texas.

19. Personal jurisdiction over Toyota Motor Corporation is established when a summons is served or a waiver of service is filed, pursuant to Fed. R. Civ. P. 4(k)(2), as Toyota Motor Corporation is not subject to jurisdiction in any state's courts of general jurisdiction and exercising jurisdiction is consistent with the United States Constitution and laws.

20. Venue is proper in this District under 28 U.S.C. §§ 1391 (b) and (c) and 1400(b). Defendants are subject to personal jurisdiction in this District, have transacted business in this District, and have committed acts of patent infringement in this District.

21. As to Toyota defendants Toyota Motor North America, Inc., Toyota Motor Sales, U.S.A., Inc., and Toyota Motor Engineering & Manufacturing North America, Inc., venue is proper in this District under §1400 (b), which provides that "Any civil action for patent infringement may be brought in the judicial district where the defendant resides, or where the defendant has committed acts of infringement and has a regular and established place of business." Venue is proper as to Toyota Motor North America, Inc. because it has a regular and established place of business in this District at 6565 Headquarters Drive, Plano, Texas 75024 and has committed acts of infringement here, including making, using, selling, and offering for sale the accused products. Venue is proper as to Toyota Motor Sales, U.S.A., Inc. because it has a regular and established place of business in this District at 6565 Headquarters Drive, Plano, Texas 75024 and has committed acts of infringement here, including making, using, selling, and offering for sale the accused products. Venue is proper as to Toyota Motor Engineering & Manufacturing North America, Inc. because it has a regular and established place of business in this District at

6565 Headquarters Drive, Plano, Texas 75024 and has committed acts of infringement here, including making, using, selling, and offering for sale the accused products.

22. Venue is proper as to Toyota Motor Corporation, which is organized under the laws of Japan, under 28 U.S.C. § 1391(c)(3), which provides that “a defendant not resident in the United States may be sued in any judicial district, and the joinder of such a defendant shall be disregarded in determining where the action may be brought with respect to other defendants.”

BACKGROUND

23. AGNC was founded by Ching-Fang Lin, Ph.D. in 1986 as a California corporation. AGNC’s headquarters are at 888 Easy Street, Simi Valley, California 93065. AGNC is the owner of record and assignee of 79 issued United States patents, including the Patents-in-Suit.

24. Dr. Lin previously received his doctorate in Computer, Information, and Control Engineering from the University of Michigan in Ann Arbor.

25. Dr. Lin authored over 400 technical publications and was responsible for over 100 patent application filings at AGNC, including as an inventor on each of the Patents-in-Suit.

26. Dr. Lin was responsible for over 1,000 government contract reports and led the effort to introduce over 30 Guidance, Navigation, Control and Communications (GNCC) products.

27. Dr. Lin’s achievements and awards include: SBA Small Business Person of the Year 2002, NASA Space Act Award Recognition for Inventions and Scientific and Technical Exceptional Contributions, Multiple Multiyear NASA Innovative Invention Award, Donald P. Eckman Award Nominee for Outstanding Control Engineer, Nominee for the Mechanics and Control of Flight Award, among many others.

28. AGNC is an operating high technology company that specializes in inventing and applying advanced and innovative technologies to contemporary problems within the fields of

Guidance, Navigation, Control and Communications (GNCC), Inertial Sensors, Health Monitoring, Intelligent Processing, and Autonomous Robotics.

29. Since its establishment in 1986, AGNC has been actively involved in pioneering efforts related to inertial sensors, interruption-free positioning, INS/GNSS fusion technologies, navigation, and collision avoidance systems that AGNC has invented, which are disclosed in its extensive patent portfolio. AGNC made the world's first MEMS rate integrating gyroscope in 1999, setting the stage for development of its coremicro® IMU product series.

30. AGNC is also among the very first companies to patent micro-electromechanical (MEMS) Inertial Measurement Unit ("IMU") technology, which is commonly found in most handheld consumer electronics such as tablets and smartphones.

31. AGNC analyzed positioning and navigation technologies and led breakthrough efforts during the late 1990's and early 2000's for the advancement of inertial sensors and navigation and collision avoidance systems.

32. AGNC's patented solutions are now found on consumer products for applications such as electronic stability control, navigation, and collision avoidance.

33. More information about Plaintiff and its products can be found at AGNC's website, www.americangnc.com.

34. As of the date of this complaint, AGNC has licensed its patents to six companies.

35. Prior to filing this lawsuit, AGNC attempted to resolve its claims against Toyota without litigation as set forth in detail below.

36. Toyota has not agreed to enter into a license agreement with AGNC.

THE PATENTS-IN-SUIT AND CLAIMS-IN-SUIT

37. AGNC is the owner of record and assignee of each of U.S. Patent Nos. 6,311,555; 6,411,871 and 6,480,789 (the “Patents-in-Suit”).

38. AGNC had and has the exclusive right to sue and recover damages for infringement of the Patents-in-Suit during all relevant time periods.

39. On November 6, 2001, U.S. Patent No. 6,311,555 (the “’555 Patent”) entitled “Angular Rate Producer with Microelectromechanical System Technology” was duly and legally issued by the United States Patent and Trademark Office (“USPTO”).

40. The ’555 Patent claims comprise elements and/or combinations of elements that constitute an inventive concept and/or were unconventional, not routine, and not well-understood by a skilled artisan at the time of the invention in order to overcome the obstacles in producing angular rate microelectromechanical systems, for example.

41. The ’555 Patent’s claims’ elements and/or combinations of elements overcame, at the time of invention, the problems with using microelectromechanical system (MEMS) technology to produce accurate angular rate signals.

42. On June 25, 2002, U.S. Patent No. 6,411,871 (the “’871 Patent”) entitled “Autonomous Navigation, Guidance and Control using LDRI” was duly and legally issued by the USPTO.

43. The ’871 Patent claims comprise elements and/or combinations of elements that constitute an inventive concept and/or were unconventional, not routine, and not well-understood by a skilled artisan at the time of the invention in order to overcome the obstacles in autonomous navigation, for example.

44. The '871 Patent's claims' elements and/or combinations of elements overcame, at the time of invention, the problems of developing autonomous vehicle navigation.

45. On November 11, 2002, U.S. Patent No. 6,480,789 (the "'789 Patent") entitled "Positioning and Proximity Warning Method and System thereof for Vehicle" was duly and legally issued by the USPTO.

46. The '789 Patent claims comprise elements and/or combinations of elements that constitute an inventive concept and/or were unconventional, not routine, and not well-understood by a skilled artisan at the time of the invention in order to overcome the obstacles in optimizing proximity warnings, for example.

47. The '789 Patent's claims' elements and/or combinations of elements overcame, at the time of invention, the problems of optimizing proximity warnings. By utilizing the '789 Patent claims' elements and/or combinations of elements, a vehicle is able to receive warning information when it comes within proximity of potential hazards.

48. AGNC asserts that Toyota has been and now is infringing, directly and by inducement, at least the following claims of the Patents-in-Suit in this District and elsewhere in the United States:

- '555 Patent - claims 49 and 50;
- '871 Patent – claim 1;
- '789 Patent – claim 22.

TOYOTA'S INFRINGING PRODUCTS

49. Toyota has been, and now is, directly infringing claims of the Patents-in-Suit under 35 U.S.C. § 271(a) by making, using, offering for sale, selling, and/or importing the below accused vehicles and yaw rate sensors in this District and elsewhere in the United States that include the

systems claimed in the Patents-in-Suit and/or by using the methods claimed in the Patents-in-Suit, including, for example, Toyota's use of said methods during set-up, testing, and demonstration of its vehicles and yaw rate sensors.

50. Toyota has been and now is inducing the direct infringement of method claims of the Patents-in-Suit pursuant to U.S.C. § 271(b) at least by one or more of making, using, offering for sale, selling and/or importing the below accused vehicles and yaw rate sensors in this District and elsewhere in the United States that were designed and intended to use and/or practice the methods and processes covered by the Patents-in-Suit. On information and belief, Toyota Motor Engineering & Manufacturing North America has been and now is engaging in direct infringement based on the testing of vehicles and/or yaw rate sensors at its facilities. Further, Toyota Motor Sales, U.S.A., Inc., has induced infringement by, for example, selling the infringing products to third parties who then in turn sell the products to the consumer knowing that the claimed methods of the Patents-in-Suit are practiced by the consumer during normal operation of Toyota vehicles.

51. Despite Toyota's awareness of the Patents-in-Suit, Toyota has continued these acts of inducement with specific intent to cause and encourage direct infringement of the Patents-in-Suit with willful blindness that such activities occurred, are still occurring, and constitute direct infringement of the Patents-in-Suit.

TOYOTA'S KNOWLEDGE OF THE PATENTS-IN-SUIT, HOW THEY ARE INFRINGED, AND CONTINUED INFRINGEMENT DESPITE THAT KNOWLEDGE

52. Toyota became aware of at least AGNC's '789 and '871 Patents during its own patent prosecution activities.

53. Toyota has been aware of the '789 Patent at least as early as August 23, 2006 when the USPTO examiner cited the '789 Patent in a Notice of References Cited dated August 23, 2006

during the prosecution of Toyota Technical Center USA Inc.'s Patent Application No. 11/387,414 (now, issued U.S. Patent No. 7,167,799 assigned to Defendant Toyota Motor Corporation).

54. Toyota has been aware of the '871 Patent at least as early as November 3, 2016 when Toyota Motor Engineering & Manufacturing North America, Inc., one of the Defendants in this case, disclosed the '871 Patent in an Information Disclosure Statement dated November 3, 2017 during the prosecution of its Patent Application No. 15/205,558 (now, issued U.S. Patent No. 10,065,654).

55. Toyota also cited to the '871 Patent on May 12, 2017 when Toyota Motor Engineering & Manufacturing North America, Inc., one of the Defendants in this case, disclosed the '871 Patent in an Information Disclosure Statement dated May 12, 2017 during the prosecution of its Patent Application No. 15/594,020 (now, issued U.S. Patent No. 10,061,316).

56. Toyota and its subsidiaries have cited to AGNC's issued patents or pending applications at least twelve other times.

57. Toyota has been aware of the Patents-in-Suit no later than March 15, 2018, when a letter dated March 15, 2018 was delivered via email to Mr. James Lentz, CEO, North America Region of Toyota Motor Corporation and President and COO of Toyota Motor North America, Inc.; Mr. Christopher P. Reynolds, General Counsel, Chief Legal Officer of Toyota Motor Corporation and EVP and Chief Diversity Officer of Toyota North America, Inc.; and Ms. Sandra Phillips Rogers, Group VP, General Counsel, and Chief Legal Officer of Toyota Motor North America, Inc. from Global IP Law Group, LLC, on behalf of AGNC.

58. AGNC's March 15, 2018 letter identifies the Patents-in-Suit and the Toyota products and methods AGNC contends infringes them.

59. AGNC provided claim charts setting forth AGNC's contentions of infringement for the '555, '871, and '789 Patents with the March 15, 2018 letter.

60. On March 30, 2018, AGNC's counsel received a letter from Mr. Dwayne Norton, Managing Counsel at Toyota Motor North America, Inc. indicating that Toyota was investigating AGNC's assertions,

61. On April 5, 2018 in response to the March 30, 2018, AGNC (through Global IP Law Group) sent a follow up email inviting Toyota to a call to answer any questions that Toyota may have.

62. On April 30, 2018, AGNC (through Global IP Law Group) received a letter dated April 23, 2018 from Toyota Motor Corporation that indicated that Toyota or Toyota's suppliers would contact Global IP Law Group once their evaluation was complete.

63. No one from or on behalf of Toyota contacted Global IP Law Group with regard to Toyota's infringement of AGNC's patents after the letter dated April 23, 2018.

64. No supplier has contacted AGNC (or its counsel) on behalf of Toyota with respect to Toyota's infringement of AGNC's patents after the letter dated April 23, 2018.

65. In addition to the March 15, 2018 letter and claim charts, this Complaint serves as additional notice to Toyota of the Patents-in-Suit and the manner in which they are infringed.

66. Toyota has not agreed to enter into a licensing agreement with AGNC.

67. Toyota has not provided AGNC any licensing proposal.

68. Toyota has never communicated to AGNC any argument that it does not infringe the Asserted Claims of the Patents-in-Suit.

69. Toyota has never communicated to AGNC any argument that the Asserted Claims of the Patents-in-Suit are invalid for any reason.

70. Despite knowledge of the Patents-in-Suit and knowledge of the manner in which the Patents-in-Suit are infringed as demonstrated in the provided claim charts, Toyota has continued to infringe and induce the infringement of the Patents-in-Suit.

COUNT I: INFRINGEMENT OF PAT. 6,311,555 CLAIM 49

71. AGNC reasserts and realleges paragraphs 1 through 70 of this Complaint as though set forth fully here.

72. Claim 49 of the '555 Patent provides:

Preamble to Claim 1	An angular rate producing process for measuring a vehicle angular rate, comprising the steps of:
Element A	receiving dither drive signal to maintain an oscillation of at least one set of inertial elements in an angular rate detecting unit with constant momentum, and producing angular motion-induced signals with respect to said vehicle angular rate and inertial element dither motion signals;
Element B	converting said angular motion-induced signals from said angular rate detecting unit in an interfacing circuitry into consistent and repeatable angular rate signals that are proportional to said vehicle angular rate, and converting said inertial element dither motion signals from said angular rate detecting unit in said interfacing circuitry into digital element displacement signals with predetermined phase; and
Element C	inputting said digital element displacement signals into a digital processing system and producing said dither drive signal for locking high-quality factor frequency and amplitude of said oscillating inertial elements in said angular rate detecting unit.

73. Toyota has made, used, sold, imported, and/or offered for sale (and continues to use, sell, import, sell and offer for sale) products that include a yaw rate sensor (including a gyroscope) (the “Accused Toyota Gyroscope Products”), the use of which meets each and every element of claim 49 of the '555 Patent.

74. The “Accused Toyota Gyroscope Vehicles” are Toyota, Lexus, and Scion vehicles sold after May 14, 2013 that include yaw rate sensors, including, for example:

- i. Toyota Yaw Rate Sensor part nos. 89183-48030, 89183-42010, 89183-48010, 89183-60020, 89180-12040. These parts were included in at least the 2013-2015 Scion iQs, tC; 2013-2015 Scion xB Base; 2013-14 Toyota Camry Hybrid LE, Hybrid SE, Hybrid XLE; 2013-2015 Toyota Prius One, Two, Three, Four, Five and Persona.
- ii. Lexus Yaw Rate Sensor part nos. 89183-48020 – Included in at least the 2016-2019 Lexus IS 200t; 2014-2015 Lexus IS 250; 2014-2019 Lexus IS 350; 2018-2019 Lexus LC 500; 2018-2019 Lexus LC 500h Hybrid; 2013-2017 Lexus LS 460; 2013-2017 Lexus LS 460L; 2013-2016 Lexus LS 600h; 2016-2019 Lexus RC 200t 2.0L; 2015-2019 Lexus RC 200t 3.5L; 2016-2019 Lexus RC 300 2.0L; 2015-2019 Lexus 300 3.5L; 2016-2019 Lexus RC 350 2.0L; 2015-2019 Lexus RC 3.5L; 2015-2019 Lexus RC F.
- iii. Toyota/Lexus Yaw Rate Sensor part nos. 89183-12050 – Included in at least the 2013 Toyota Highlander; 2013 Toyota Corolla; 2013-2015 Scion xB; 2013-2015 Lexus RX350.

75. The “Accused Toyota Gyroscope Yaw Rate Sensors” are the yaw rate sensors that Toyota makes, uses, imports, sells, and offers for sale (including through its distributors and parts dealers). The “Accused Toyota Gyroscope Yaw Rate Sensors” include at least the following yaw rate sensors: 89183-48030, 89183-42010, 89183-48010, 89183-60020, 89180-12040, 89183-48020, and 89183-12050.

76. The “Accused Toyota Gyroscope Products” include both the “Accused Toyota Gyroscope Vehicles” and the “Accused Toyota Gyroscope Yaw Rate Sensors.”

77. The Accused Toyota Gyroscope Products contain gyroscopes (“Accused Gyroscopes.”).

78. For example, the Toyota 89183-48030 Yaw Rate Sensor contains a Panasonic gyroscope (labeled S54XD).

79. The Toyota 89183-48030 Yaw Rate Sensor is pictured below:

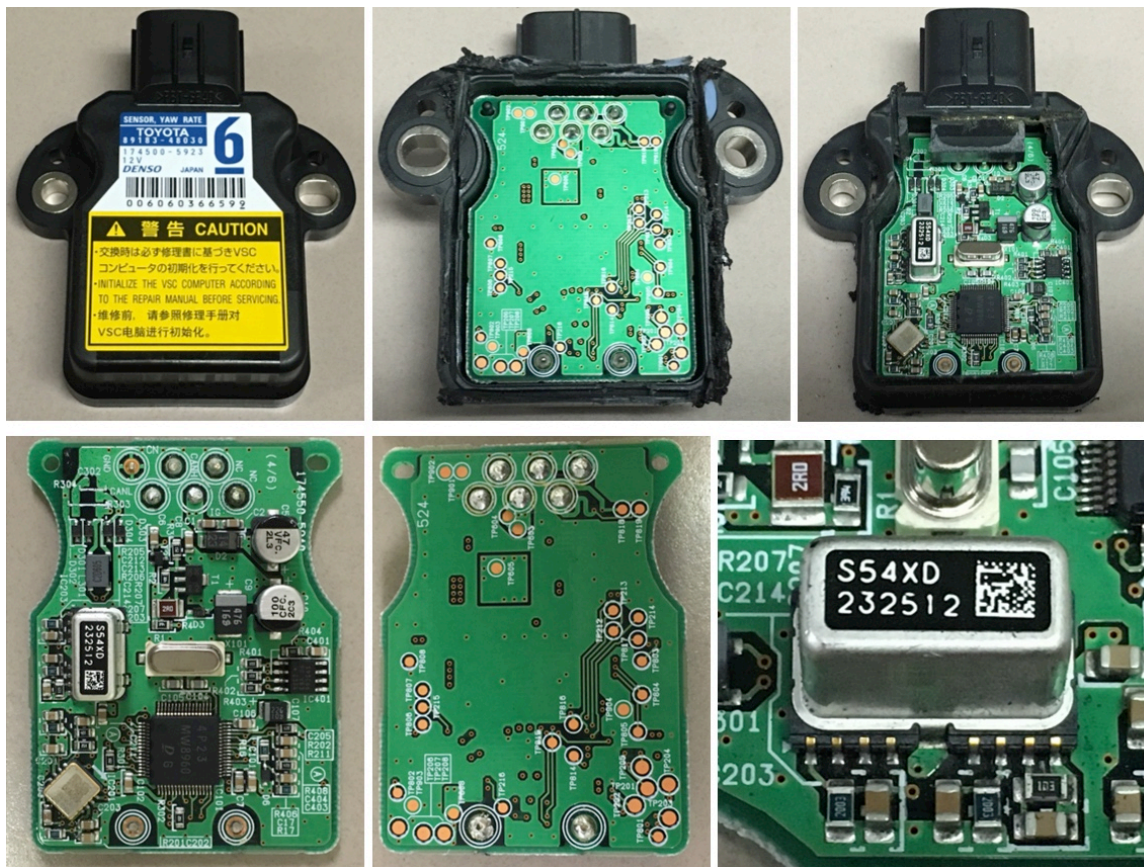

80. The Panasonic gyroscope (labeled S54XD) from within the Toyota 89183-48030 Yaw Rate Sensor is pictured above.

81. As another example, the Toyota 89183-60020 Yaw Rate Sensor contains a Panasonic gyroscope (labeled EWTS52AB).

82. The Toyota 89183-60020 Yaw Rate Sensor is pictured below:



83. The Panasonic gyroscope (labeled EWT52AB) from within the Toyota 89183-60020 Yaw Rate Sensor is pictured above.

84. The Panasonic gyroscopes in the Accused Toyota Gyroscope Products are described by Panasonic's websites and datasheets, available for example, at <https://industrial.panasonic.com/cdbs/www-data/pdf/ARC0000/ARC0000COL2.pdf>; <https://industrial.panasonic.com/ww/products/sensors/sensors/angular-rate-sensors>; <https://industrial.panasonic.com/ww/products/sensors/sensors/angular-rate-sensors/gyro-sensors-general-purpose>; <https://industrial.panasonic.com/ww/products/sensors/sensors/angular-rate-sensors/gyro-sensors-general-purpose2>; <https://www.datasheets.com/en/datasheet/ewts82-panasonic-45197626>; <https://industrial.panasonic.com/ww/products/sensors/sensors/angular-rate-sensors/mems-gyro-sensors-rollover-detection>;

<https://eu.industrial.panasonic.com/products/sensors-optical-devices/sensors-automotive-and-industrial-applications/angular-rate-sensors>.

85. The Accused Toyota Gyroscope Products perform an angular rate producing process for measuring an angular rate.

86. A gyroscope measures angular rate.

87. The gyroscopes in the Accused Toyota Gyroscope Products have an angular rate detecting unit (e.g., drive element, tuning fork, drive sensor, and Coriolis sensor).

88. As one example, the Panasonic S54XD gyroscope is shown below:

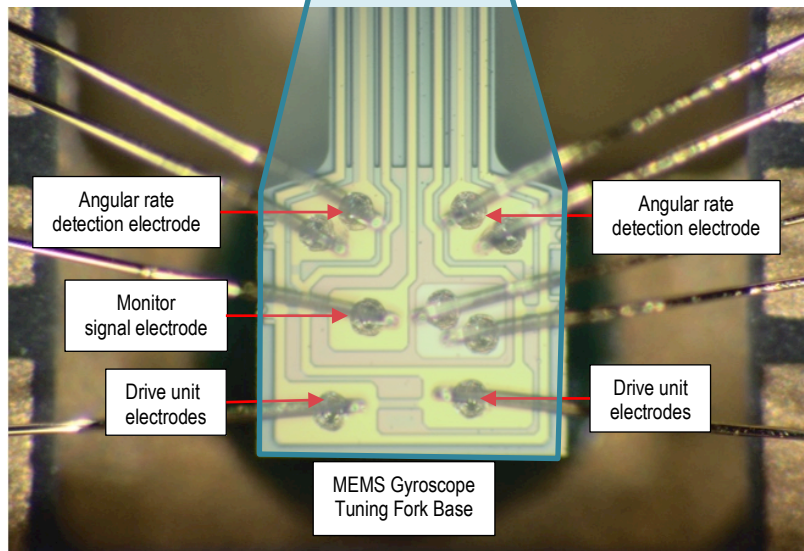
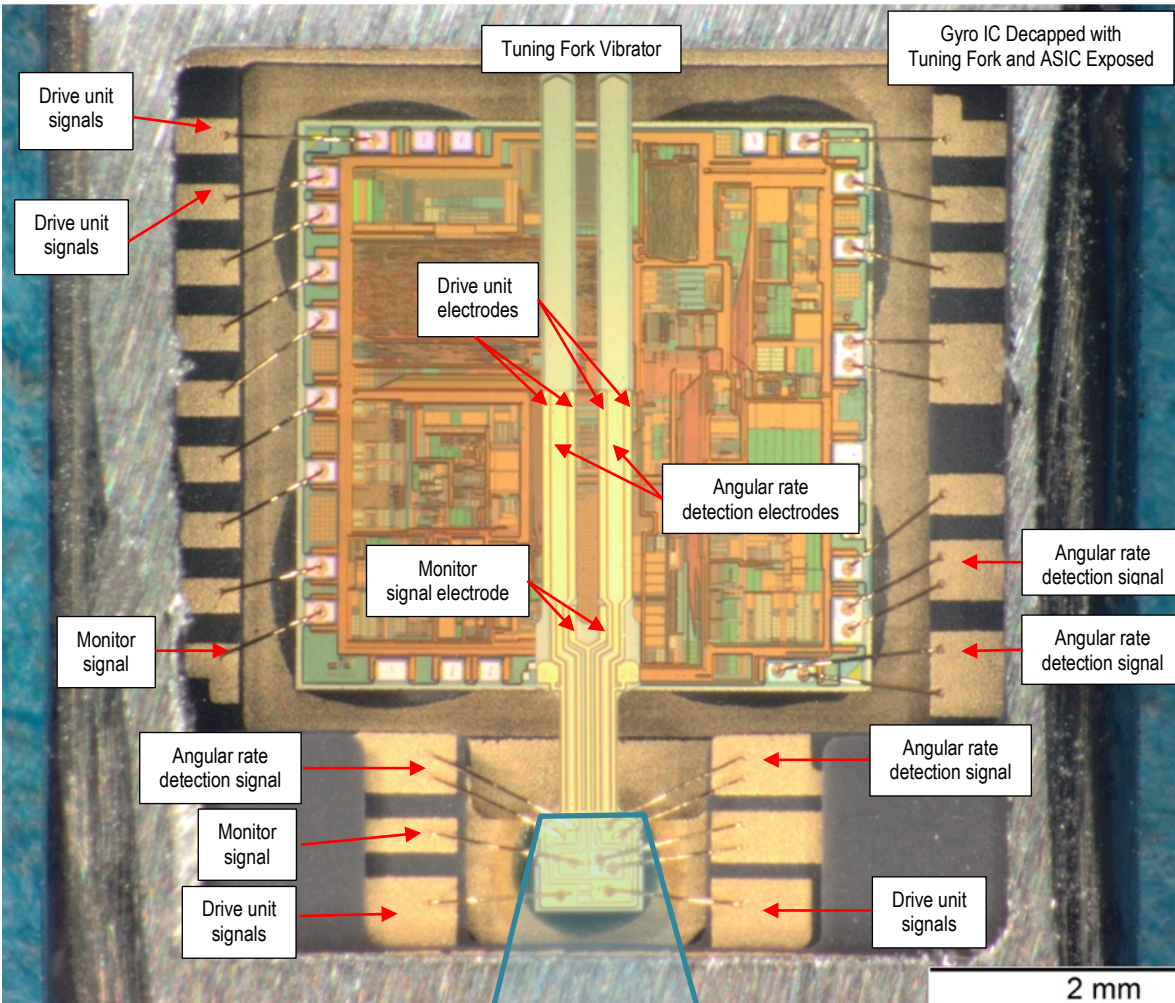

89. As one example, the Panasonic EWTS52AB gyroscope is shown below (note, the tuning fork tines broke off during decapsulation):

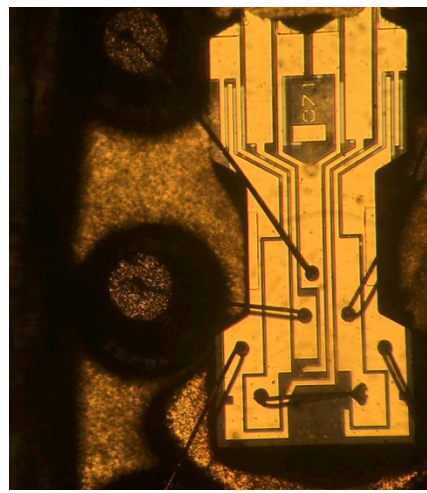
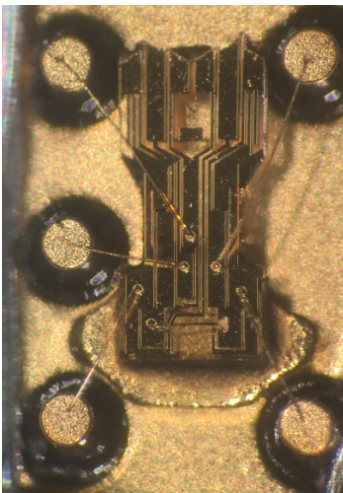
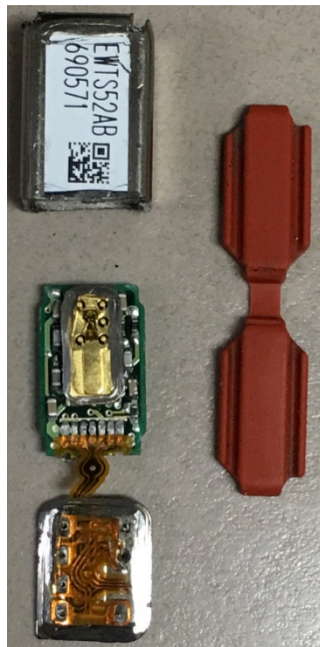
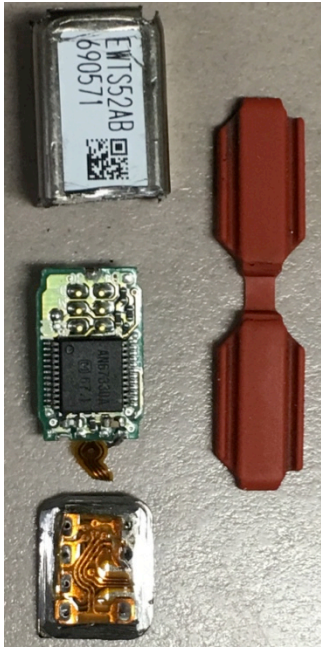

91. The Accused Gyroscopes contain a driving structure that uses a drive signal (e.g., dither drive signal) to oscillate a set of moveable masses (e.g., the tuning fork's tines, inertial elements).

92. The Accused Gyroscopes have a drive-loop that oscillates (e.g., vibrates) the driving structure (e.g., vibration at resonance), a monitor signal that monitors this vibration, and a sense signal related to the Coriolis force detected by the sensor.

93. The Accused Gyroscopes' drive-loop has amplitude control circuitry (e.g., automatic gain control) to maintain constant momentum (e.g., constant vibration amplitude/magnitude) (e.g., the tuning fork tines are in oscillation with constant momentum).

94. For example, Panasonic's General Information documentation on Panasonic Gyro Sensors (available at <https://industrial.panasonic.com/cdbs/ww-data/pdf/ARC0000/ARC0000COS2.pdf>) provides the following figures (annotations added):

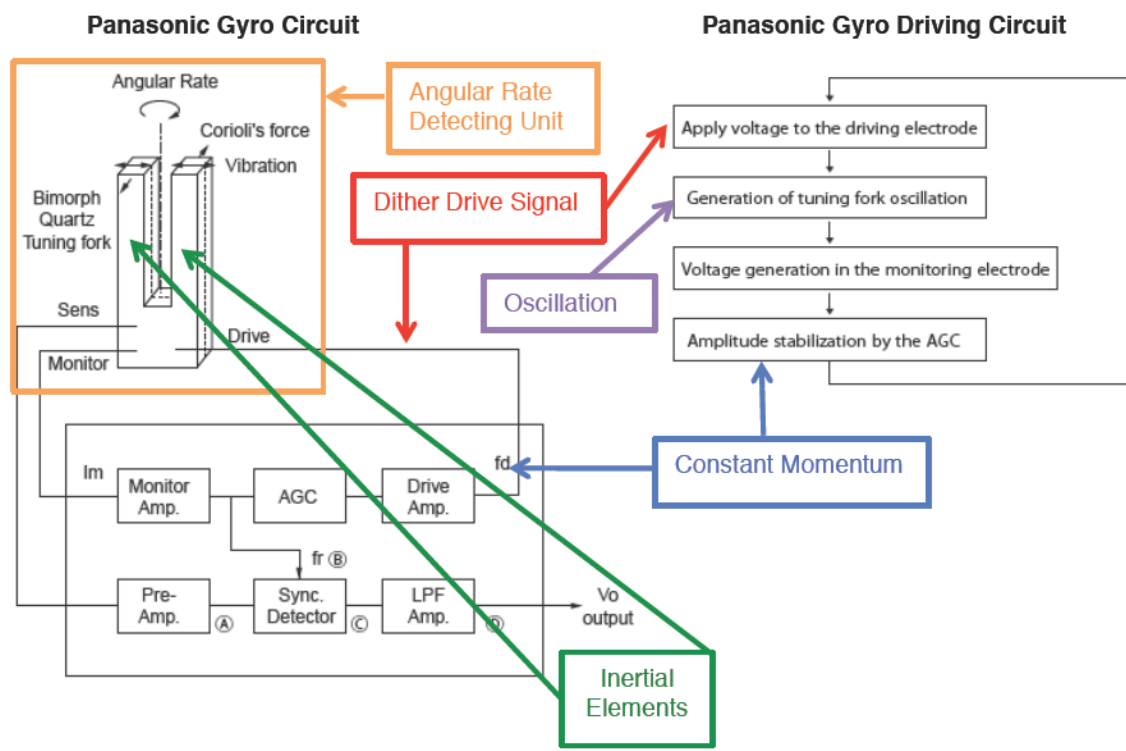

95. Panasonic's General Information documentation on Panasonic Gyro Sensors (available at <https://industrial.panasonic.com/cdbs/ww-data/pdf/ARC0000/ARC0000COS2.pdf>) also provides the following information (annotations added):

(1)Driving Circuit

It generates the particular frequency of the tuning fork through the following oscillation loop. In order to stabilize the sensitivity, the amplitude is controlled by the AGC

(2)Detection Circuit

Applying angular rate to the sensor, the tines of tuning fork are twisted by CORIOLIS force and generate waves as shown in Fig 1 below. This is equivalent to the signal which is amplitude - modulated by the angular rate signal $f\omega$, using the driving frequency f_d as the carrier waves. Thus the angular rate signal is extracted by the synchronized detection using driving frequency f_r as base signal

96. The Accused Gyroscopes' drive-loop also has circuitry that maintains a particular frequency to maintain the constant momentum (e.g., constant vibration frequency) (e.g., the tuning fork tines are in oscillation with constant momentum).

97. The Accused Gyroscopes' inertial elements (e.g., tuning fork tines) are driven (e.g., by dither drive signals) to resonate by torque exerted by driving electrodes while also providing automatic gain control (e.g., control of the displacement, or amplitude/magnitude, of the driving electrodes) that is used to constantly drive the momentum.

98. In the Accused Gyroscopes, the driving electrodes excite the tuning fork to oscillate at a particular frequency.

99. The Accused Gyroscopes have drive signals that drive the tuning fork tines/inertial elements at a resonant frequency (e.g., resonant vibration) to maintain constant momentum.

100. The Accused Gyroscopes' angular rate detecting unit produces angular-motion induced signals with respect to the angular rate experienced by the Accused Toyota Gyroscope Product.

101. For example, Panasonic's General Information documentation on Panasonic Gyro Sensors (available at <https://industrial.panasonic.com/cdbs/ww-data/pdf/ARC0000/ARC0000COS2.pdf>) provides the following figures (annotations added):

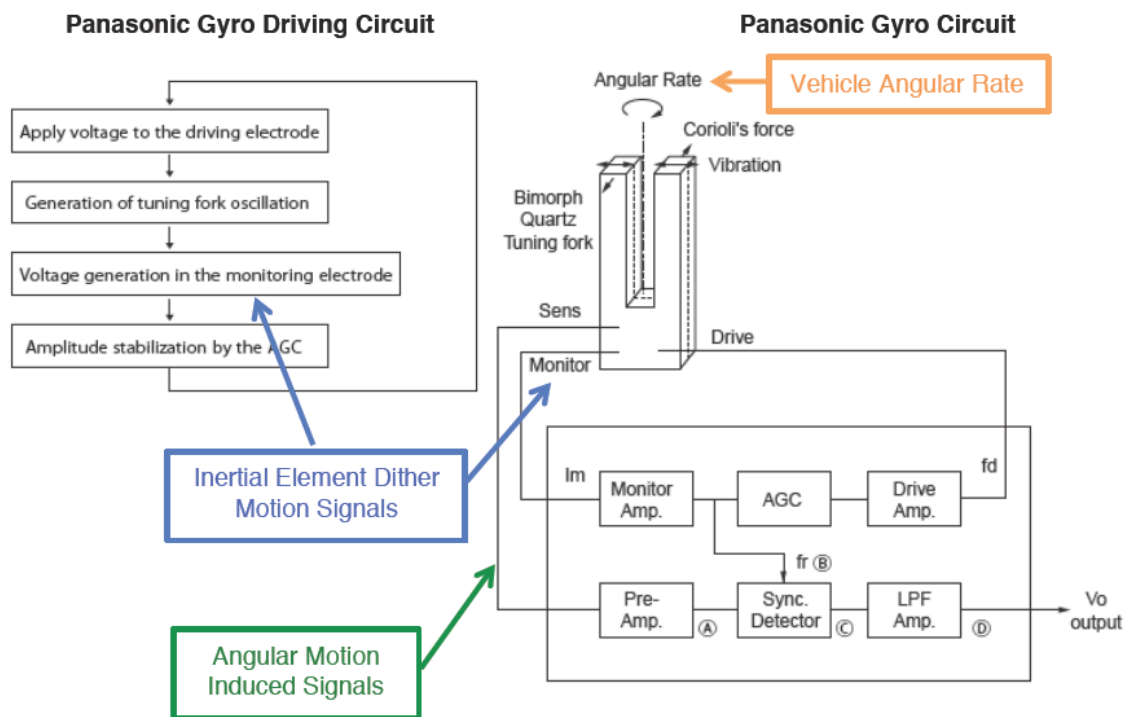

102. Panasonic’s General Information documentation on Panasonic Gyro Sensors (available at <https://industrial.panasonic.com/cdbs/ww-data/pdf/ARC0000/ARC0000COS2.pdf>) also provides the following information (annotations added):

(2)Detection Circuit

Applying angular rate to the sensor, the tines of tuning fork are twisted by CORIOLIS force and generate waves as shown in Fig 1 below. This is equivalent to the signal which is amplitude - modulated by the angular rate signal f_{ω} , using the driving frequency f_d as the carrier waves. Thus the angular rate signal is extracted by the synchronized detection using driving frequency f_r as base signal

103. The movement (e.g. twisting) of the tuning fork tines due to rotation causes a capacitance change that is picked up by the sensing element’s (e.g., Coriolis sensor) sensor that produces a voltage signal in response.

104. The voltage signal is proportional to the applied angular rate, e.g., the voltage signal produced is an angular motion-induced signal with respect to the vehicle angular rate of the Accused Toyota Gyroscope Products.

105. The Accused Gyroscopes' angular rate detecting unit produces monitor signals that monitor the vibration of the tuning fork tines (e.g., inertial element dither motion signals).

106. For example, Panasonic's General Information documentation on Panasonic Gyro Sensors (available at <https://industrial.panasonic.com/cdbs/ww-data/pdf/ARC0000/ARC0000COS2.pdf>) provides the following figures (annotations added):

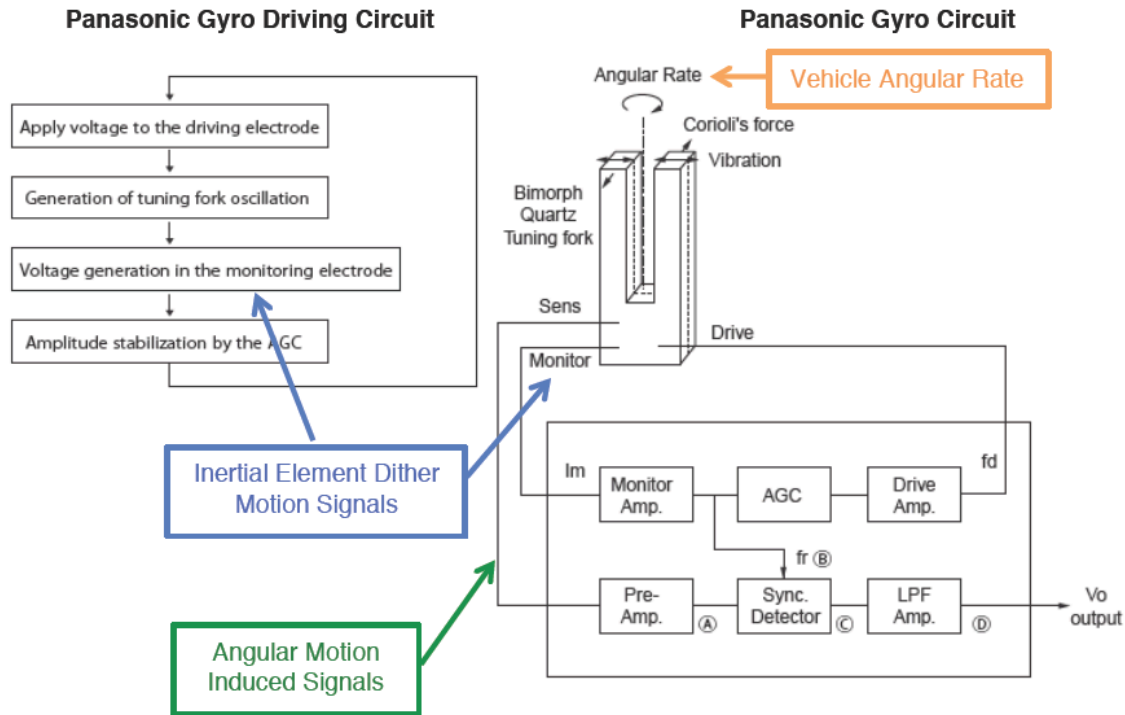

107. The Accused Gyroscopes have interfacing circuitry that converts the voltage signal proportional to the applied angular rate (e.g., angular motion-induced signals) into consistent and repeatable angular rate signals that are proportional to the vehicle angular rate.

108. For example, Panasonic's General Information documentation on Panasonic Gyro Sensors (available at <https://industrial.panasonic.com/cdbs/ww-data/pdf/ARC0000/ARC0000COS2.pdf>) provides the following figures (annotations added):

Panasonic Gyro Signal Processing Chain and Output Characteristic

[Signal Processing]

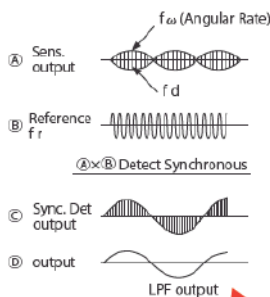

Angular Motion Induced Signals

Panasonic Gyro Circuit

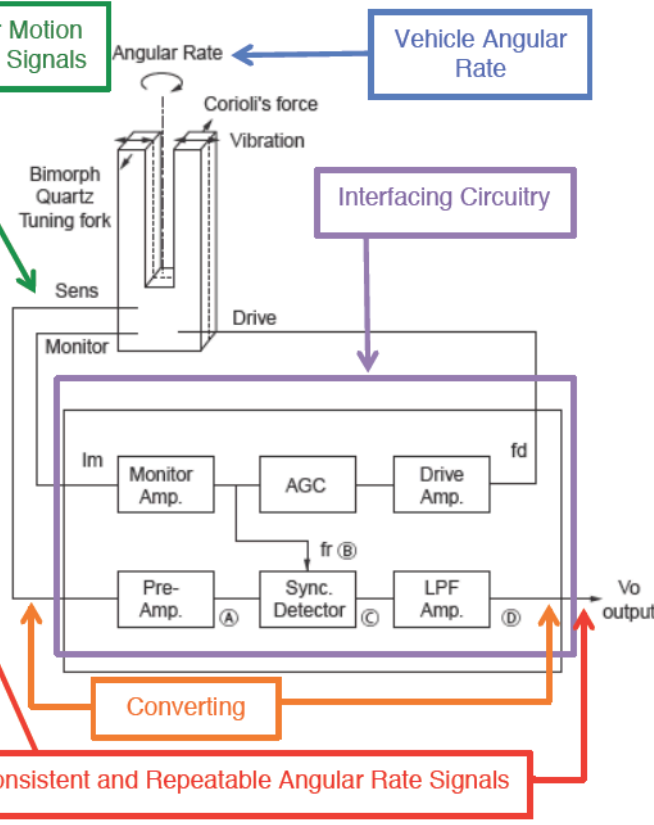

[Output Characteristic]

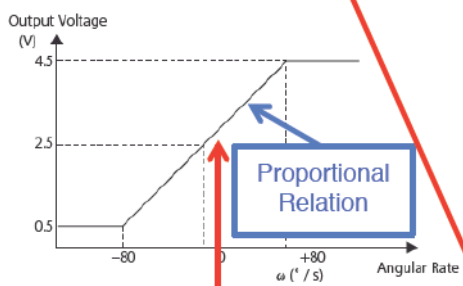

109. Panasonic’s General Information documentation on Panasonic Gyro Sensors (available at <https://industrial.panasonic.com/cdbs/ww-data/pdf/ARC0000/ARC0000COS2.pdf>) also provides the following information (annotations added):

(2)Detection Circuit

Applying angular rate to the sensor, the tines of tuning fork are twisted by CORIOLIS force and generate waves as shown in Fig 1 below. This is equivalent to the signal which is amplitude - modulated by the angular rate signal f_{ω} , using the driving frequency f_d as the carrier waves. Thus the angular rate signal is extracted by the synchronized detection using driving frequency f_r as base signal

(1)Driving Circuit

It generates the particular frequency of the tuning fork through the following oscillation loop. In order to stabilize the sensitivity, the amplitude is controlled by the AGC

110. In the Accused Gyroscope, the voltage signal produced is amplified, modulated, and filtered to produce a voltage signal that is proportional to the angular rate.

111. Therefore, the angular rate signal is extracted by synchronized detection from the angular motion-induced signals.

112. The Accused Gyroscopes convert the angular motion-induced signals from the angular detecting unit in an interfacing circuitry into consistent and repeatable angular rate signals.

113. The consistent and repeatable angular rate signals are proportional to the vehicle angular rate.

114. That is, there is a linear (and therefore, proportional) relationship between the angular rate experienced by the Accused Toyota Gyroscope Product and the output voltage of the angular rate signal for the sensitivity range of the Accused Gyroscopes.

115. Within that sensitivity range, a given angular rate will yield the same output voltage.

116. For example, the Accused Gyroscopes include a sense path that detects the motion caused by Coriolis acceleration, a Pre-Amp., a Sync. Detector that recovers the rotation signal, and a LPF Amp. that provides the angular rate output.

117. The monitor signals (e.g., inertial element dither motion signals) are also fed into interfacing circuitry.

118. For example, Panasonic's General Information documentation on Panasonic Gyro Sensors (available at <https://industrial.panasonic.com/cdbs/ww-data/pdf/ARC0000/ARC0000COS2.pdf>) provides the following figures (annotations added):

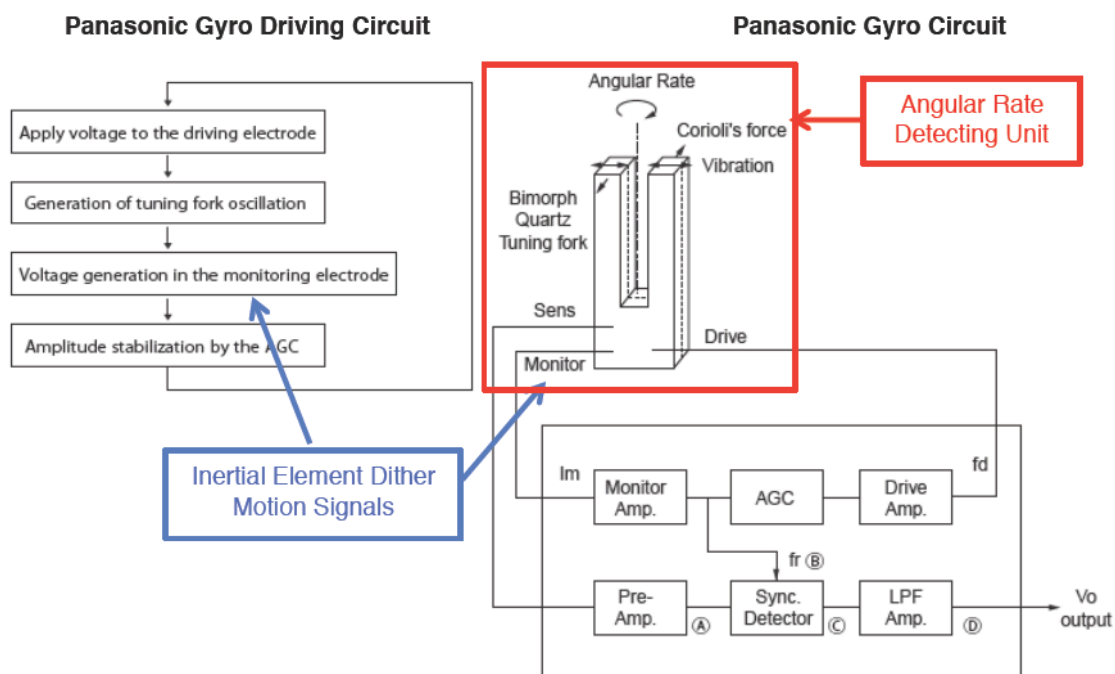

119. The Accused Gyroscopes convert the inertial element dither motion signals from the angular rate detecting unit in interfacing circuitry into digital element displacement signals.

120. The digital element displacement signals are further processed to have a predetermined phase.

121. For example, in the Accused Gyroscopes' architecture, the drive-loop consists of a capacitive position sensing stage and a phase locked loop to oscillate the MEMS structure at resonance.

122. The Accused Gyroscopes' architecture also includes amplitude control circuitry (e.g., automatic gain control) that effectively controls the displacement of the inertial elements.

123. The Accused Gyroscopes input the digital element displacement signals into a digital processing system and produce the dither drive signal.

124. The dither drive signal locks the high-quality factor frequency of the oscillating inertial elements (e.g., tuning fork tines) in the angular rate detecting unit.

125. The dither drive signal locks the amplitude/magnitude of the oscillating inertial elements (e.g., tuning fork tines) in the angular rate detecting unit.

126. The digital element displacement signals are input to a phase locked loop to lock a high-quality factor frequency.

127. The phase locked loop elements feed into a controller that controls the oscillation of the inertial elements.

128. For example, the Accused Gyroscope’s drive loop includes a phase lock loop that outputs an in-phase signal (which is in phase with the drive signal) and an automatic gain control (AGC) circuit to generate a drive signal.

129. The drive signal is then provided to the drive element that generates the force to vibrate the tuning fork tines.

130. For example, Panasonic’s General Information documentation on Panasonic Gyro Sensors (available at <https://industrial.panasonic.com/cdbs/ww-data/pdf/ARC0000/ARC0000COS2.pdf>) provides the following figures (annotations added):

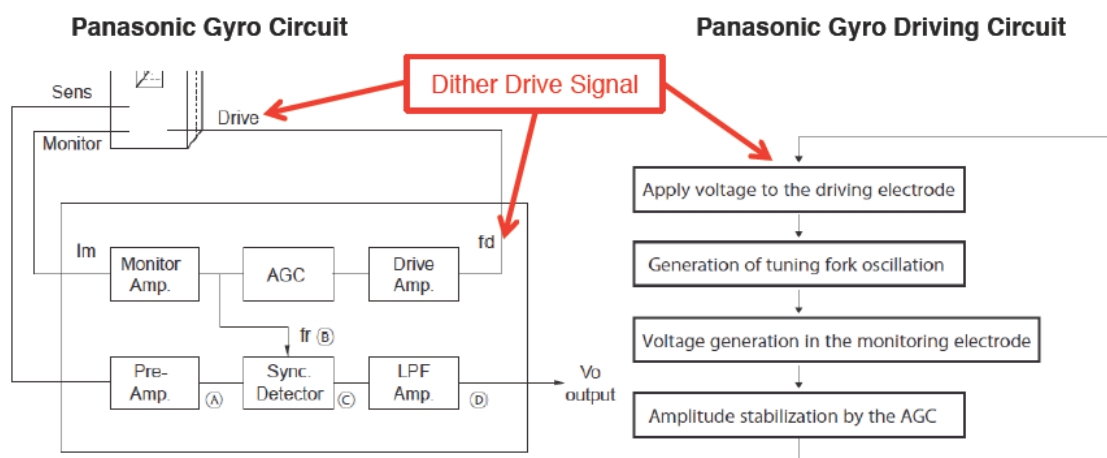

131. The Accused Gyroscopes utilize a Phase-Lock Loop (“PLL”) in the digital processing system to control the phase and an Automatic Gain Control (“AGC”) circuit to control the amplitude/magnitude.

132. Direct infringement of claim 49 of the '555 Patent occurs whenever the Accused Gyroscopes are active while the Accused Toyota Gyroscope Products are used.

133. Toyota directly infringes claim 49 of the '555 Patent by making, selling, and importing the Accused Toyota Gyroscope Products which, by design, practice the claimed process.

134. In addition, Toyota directly infringes claim 49 of the '555 Patent under 35 U.S.C. § 271(a) by using the Accused Toyota Gyroscope Products and/or Accused Gyroscopes, including in relation to product demonstrating and testing.

135. In the alternative, to the extent that any steps of the methods covered by claim 49 of the '555 patent are performed by third-parties, such as Toyota's customers (e.g., dealers) or users of the Accused Toyota Gyroscope Products (e.g., customers who purchased a Toyota vehicle), Toyota induces infringement of claim 49 of the '555 Patent including by distributing the Accused Toyota Gyroscope Products that practice the claimed process in ordinary use. Toyota's technical design of its products including its yaw rate sensors/gyroscopes dictates that they will be used to infringe the claim. The Accused Toyota Gyroscope Products' gyroscope is infringing when customers operate the Accused Toyota Gyroscope Products. Toyota actively induces customers and end-users to directly infringe each and every claim limitation of at least claim 49 of the '555 Patent under 35 U.S.C. § 271(b).

136. In the alternative, Toyota induces infringement of claim 49 of the '555 Patent by end users including by distributing the Accused Toyota Gyroscope Products that practice the claimed process in ordinary use.

137. The Accused Toyota Gyroscope Products' gyroscope is active, at least some of the time, whenever Toyota or its customers operate the Accused Toyota Gyroscope Products.

138. Toyota has had actual knowledge of the '555 Patent and AGNC's allegations of how the Accused Toyota Gyroscope Products infringe claim 49 of the '555 Patent since at least March 15, 2018.

139. Toyota has been and is knowingly inducing its customers and/or end users to directly infringe at least claim 49 of the '555 Patent with the specific intent to encourage such infringement, and knowing that the acts induced constitute patent infringement. Toyota's inducement includes, for example, encouraging consumers to purchase the Accused Toyota Gyroscope Products, and by providing, for example, technical guides, owner manuals, product data sheets, demonstrations, and other forms of support to dealers that induce them and its customers and/or end users to directly infringe claim 49 of the '555 Patent by using the Accused Toyota Gyroscope Products' gyroscope.

COUNT II: INFRINGEMENT OF PAT. 6,311,555 CLAIM 50

140. AGNC reasserts and realleges paragraphs 1 through 139 of this Complaint as though set forth fully here.

141. Claim 50 of the '555 Patent provides:

Claim 50	The angular rate producing process, as recited in claim 49 , wherein said angular rate detecting unit is a vibrating type angular rate detecting unit for detecting vehicle angular motions through Coriolis Effect and outputting said angular motion-induced signals which are voltage proportional to angular rate and torque signals.
----------	--

142. The Accused Toyota Gyroscope Products perform each of the limitations of claim 49 of the '555 Patent.

143. Toyota has and continues to make, use, sell, import, and/or offer for sale the Accused Toyota Gyroscope Products, the use of which meets each and every element of claim 50 of the '555 Patent.

144. The Accused Gyroscopes' angular rate detecting unit is a vibrating type angular rate detecting unit for detecting angular motions.

145. The Accused Gyroscopes' angular rate detecting unit is a vibrating type angular rate detecting unit for detecting angular motions through the Coriolis effect.

146. For example, both the Toyota 89183-48030 Yaw Rate Sensor's Accused Gyroscope, marked S54XD, and the Toyota 89183-60020 Yaw Rate Sensor's Accused Gyroscope, the Panasonic EWTS52AB are vibrating type angular rate detecting units (with tuning forks) that detect angular motions.

147. As one example, the Panasonic S54XD gyroscope is shown below:

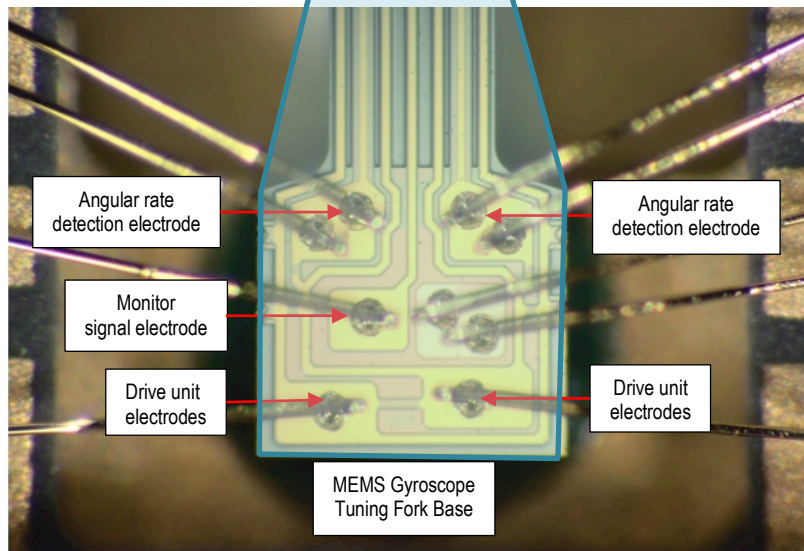
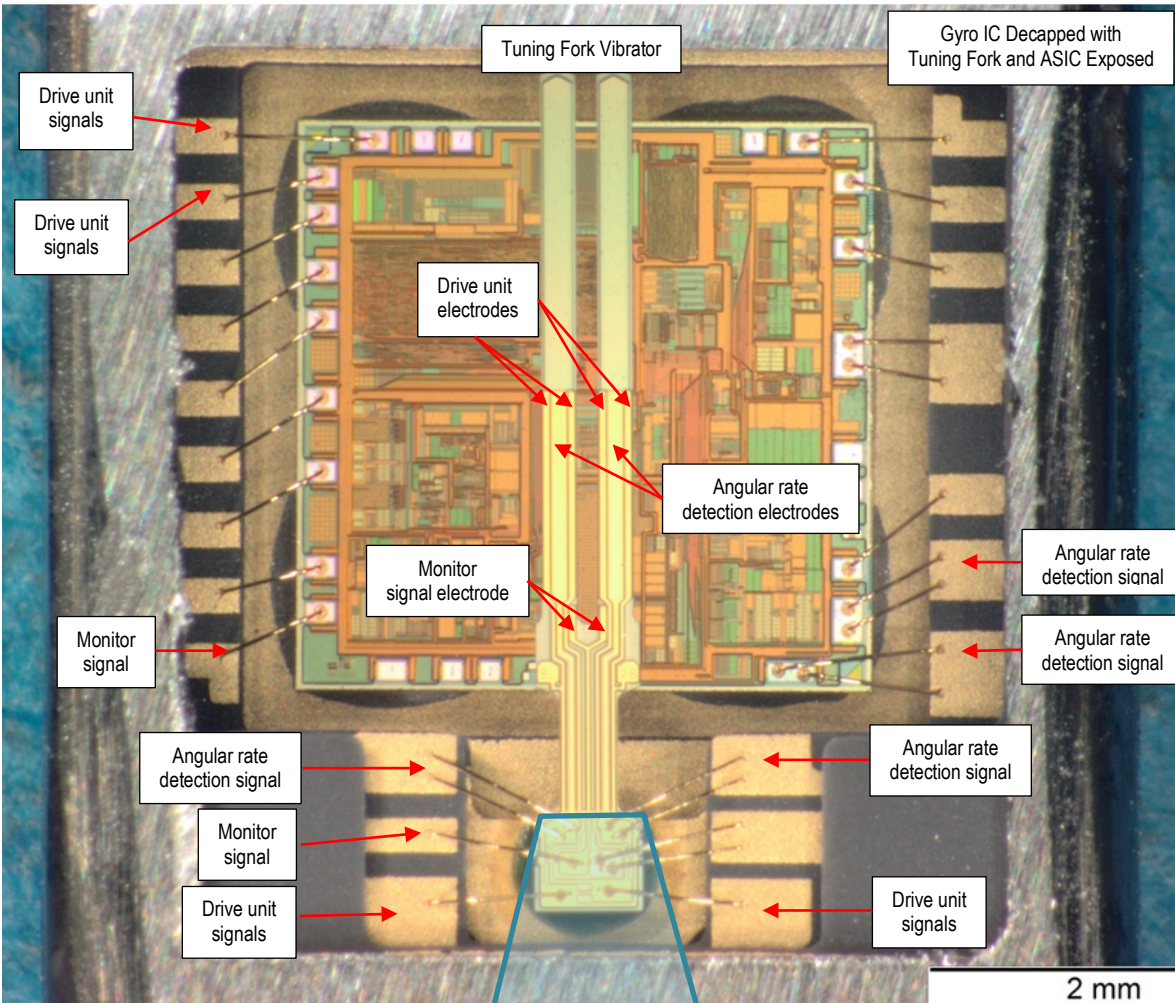

148. As one example, the Panasonic EWTS52AB gyroscope is shown below (note, the tuning fork tines broke off during decapsulation):

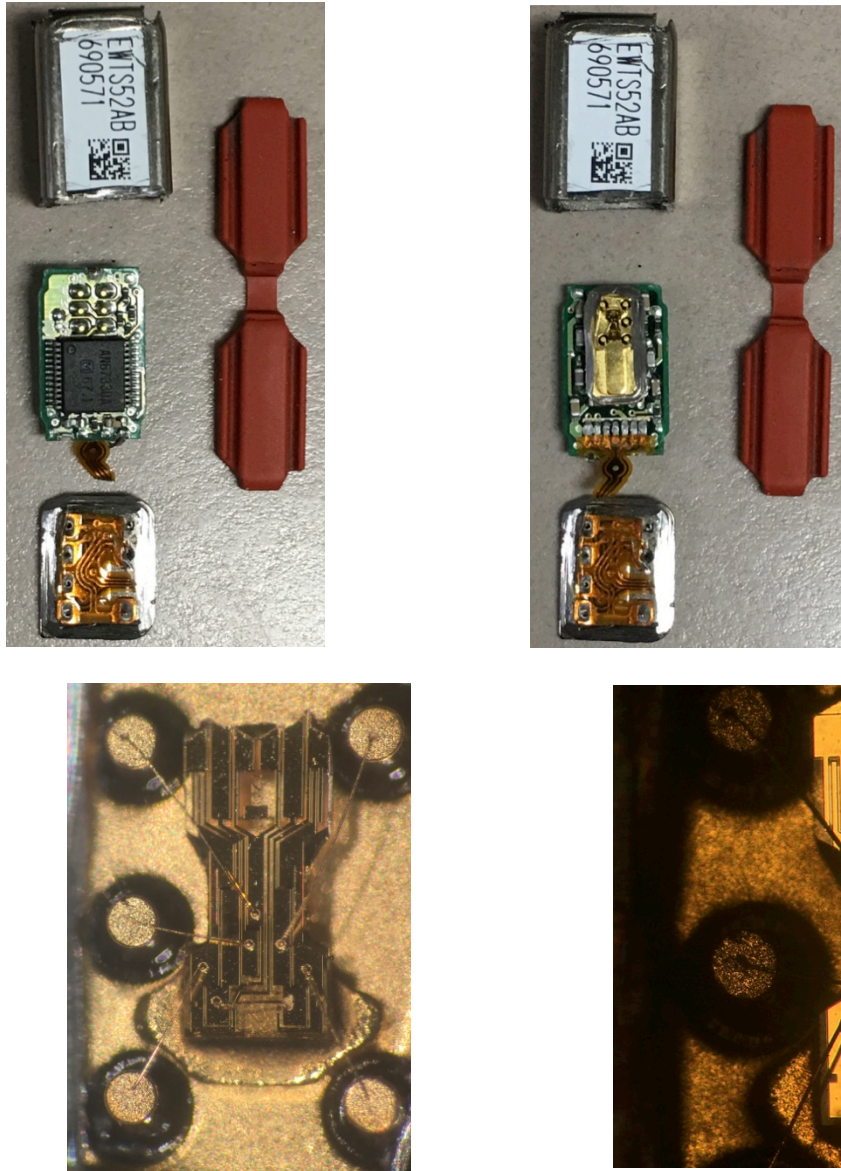

150. For example, the Accused Gyroscopes have tuning fork tines (e.g., inertial elements) that are driven into a resonant vibration.

151. The Accused Gyroscopes have drive signals that drive the tuning fork tines/inertial elements at a resonant frequency (e.g., resonant vibration) to maintain constant momentum.

152. The Accused Gyroscopes' angular rate detecting unit outputs angular motion-induced signals, which are voltages proportional to angular rate.

153. The Accused Gyroscopes have a drive-loop that oscillates (e.g., vibrates) the driving structure (e.g., vibration at resonance), a monitor signal that monitors this vibration, and a sense signal related to the Coriolis force detected by the sensor.

154. For example, Panasonic's General Information documentation on Panasonic Gyro Sensors (available at <https://industrial.panasonic.com/cdbs/ww-data/pdf/ARC0000/ARC0000COS2.pdf>) provides the following figures (annotations added):

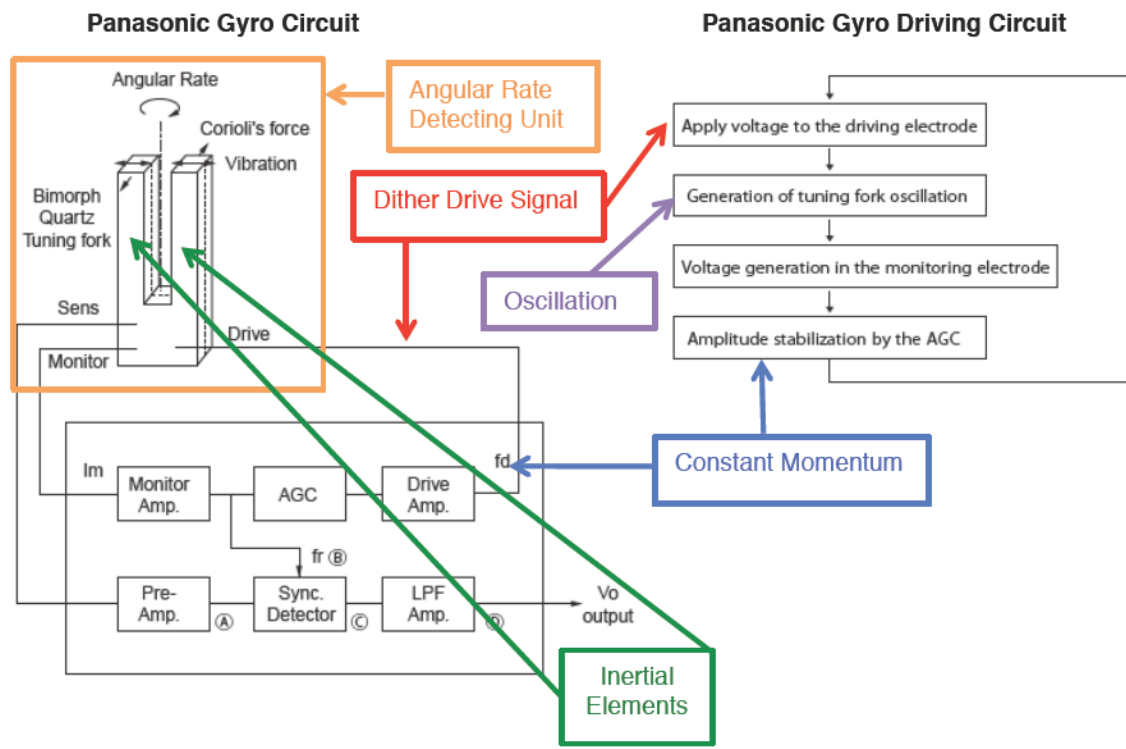

155. The movement (e.g., twisting) of the tuning fork tines due to rotation causes a capacitance change that is picked up by the sensing element's (e.g., Coriolis sensor) sensor that produces a voltage signal in response.

156. The voltage signal is proportional to the applied angular rate, e.g., the voltage signal produced is an angular motion-induced signal with respect to the vehicle angular rate of the Accused Toyota Gyroscope Products.

157. That is, there is a linear (and therefore, proportional) relationship between the angular rate experienced by the Accused Toyota Gyroscope Product and the output voltage of the angular motion-induced signal for the sensitivity range of the Accused Gyroscopes.

158. For example, Panasonic's General Information documentation on Panasonic Gyro Sensors (available at <https://industrial.panasonic.com/cdbs/ww-data/pdf/ARC0000/ARC0000COS2.pdf>) provides the following output characteristic that shows a linear relationship between the angular rate experienced by the Accused Toyota Gyroscope Product and the output voltage of the angular motion-induced signal for the sensitivity range of the Accused Gyroscopes:

[Output Characteristic]

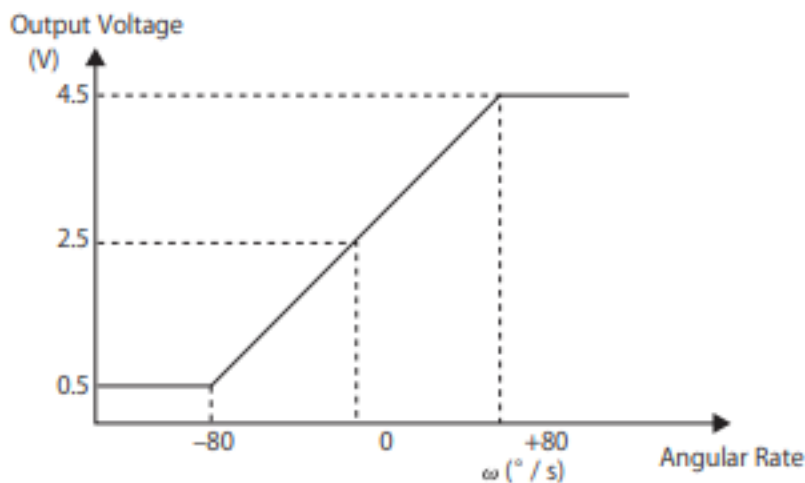

159. The Accused Gyroscopes' angular rate detecting unit outputs torque signals (e.g., inertial element dither motion signals).

160. The Accused Gyroscopes' angular rate detecting unit produces monitor signals that monitor the vibration of the tuning fork tines (e.g., inertial element dither motion signals).

161. For example, Panasonic's General Information documentation on Panasonic Gyro Sensors (available at <https://industrial.panasonic.com/cdbs/ww-data/pdf/ARC0000/ARC0000COS2.pdf>) provides the following figures (annotations added):

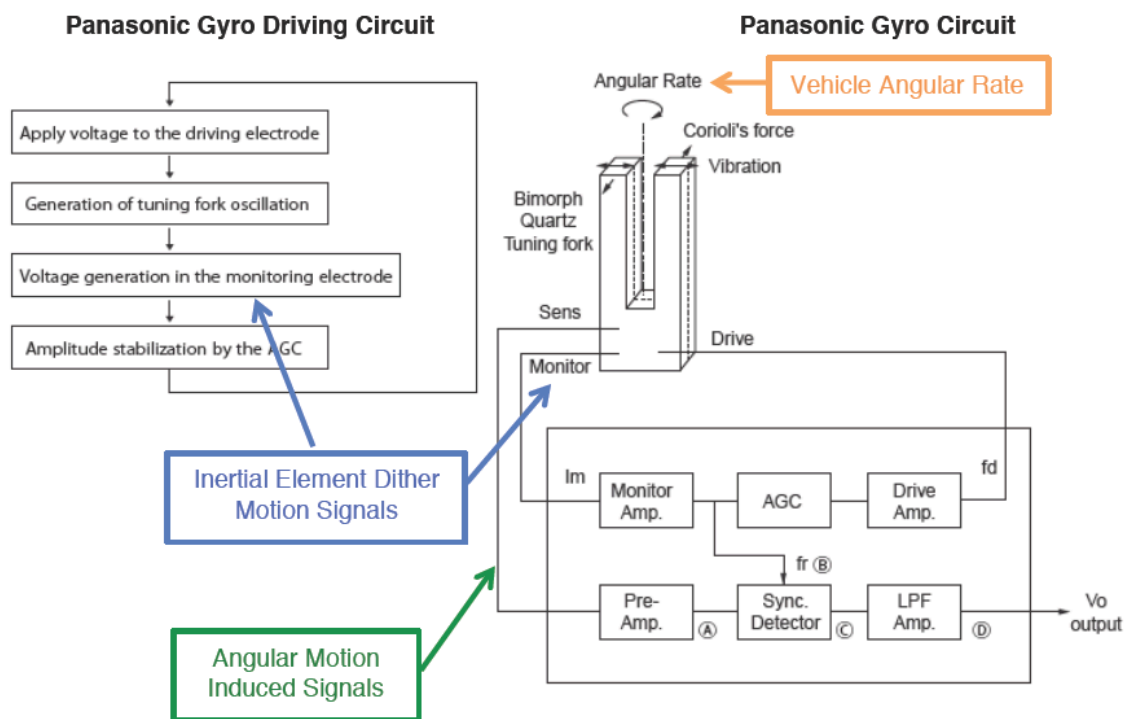

162. Direct infringement of claim 50 of the '555 Patent occurs whenever the Accused Gyroscope is active while the Accused Toyota Gyroscope Products are used in/on a vehicle.

163. Toyota directly infringes claim 50 of the '555 Patent by making, selling, and importing the Accused Toyota Gyroscope Products which, by design, practice the claimed process.

164. In addition, Toyota directly infringes claim 50 of the '555 Patent under 35 U.S.C. § 271(a) by using the Accused Toyota Gyroscope Products, including in relation to product demonstrating and testing.

165. In the alternative, to the extent that any steps of the methods covered by claim 50 of the '555 patent are performed by third-parties, such as Toyota's customers (e.g., dealers) or users of the Accused Toyota Gyroscope Products (e.g., customers who purchased a Toyota vehicle), Toyota induces infringement of claim 50 of the '555 Patent including by distributing the Accused Toyota Gyroscope Products that practice the claimed process in ordinary use. Toyota's technical design of its products including its yaw rate sensors/gyroscopes dictates that they will be used to infringe the claim. The Accused Toyota Gyroscope Products' gyroscope is infringing when customers operate the Accused Toyota Gyroscope Products. Toyota actively induces customers and end-users to directly infringe each and every claim limitation of at least claim 50 of the '555 Patent under 35 U.S.C. § 271(b).

166. In the alternative, Toyota induces infringement of claim 50 of the '555 Patent by end users including by distributing the Accused Toyota Gyroscope Products that practice the claimed process in ordinary use.

167. The Accused Toyota Gyroscope Products' gyroscope is active, at least some of the time, whenever Toyota or its customers operate the Accused Toyota Gyroscope Products.

168. Toyota has had actual knowledge of the '555 Patent since at least March 15, 2018.

169. Toyota has been and is knowingly inducing its customers and/or end users to directly infringe at least claim 50 of the '555 Patent with the specific intent to encourage such infringement, and knowing that the acts induced constitute patent infringement. Toyota's inducement includes, for example, encouraging consumers to purchase the Accused Toyota Gyroscope Products, and by providing, for example, technical guides, owner manuals, product data sheets, demonstrations, and other forms of support to dealers that induce them and its

customers and/or end users to directly infringe claim 50 of the '555 Patent by using the Accused Toyota Gyroscope Products' gyroscope.

COUNT III: INFRINGEMENT OF PAT. 6,411,871 CLAIM 1

170. AGNC reasserts and realleges paragraphs 1 through 70 of this Complaint as though set forth fully here.

171. Claim 1 of the '871 Patent provides:

Preamble to Claim 1	An autonomous navigation, guidance and control process, comprising the steps of
Element A	providing an expected reference position relative to a target;
Element B	generating a carrier position and attitude relative to said target by a Range and Intensity Images Provider;
Element C	producing a relative position and attitude error; and
Element D	producing control commands from said relative position and attitude error for relative motion dynamics.

172. Toyota has and continues to make, use, sell, import, and/or offer for sale products that include a laser cruise control system (the "Accused Toyota Cruise Products"), the use of which meets each and every element of claim 1 of the '871 Patent.

173. The Accused Toyota Cruise Products that practice the method claimed in the '871 Patent during normal operation include, but are not limited to, for example, at least the following Toyota, Lexus, and Scion vehicles sold after May 14, 2013 that feature Dynamic Laser Cruise Control: Toyota Sequoia, Avalon, and Sienna; Lexus LS 430 and RX 330.

174. The Accused Toyota Cruise Product's cruise control system, the Dynamic Laser Cruise Control, for example, performs an autonomous navigation, guidance and control process.

175. The Accused Toyota Cruise Product's cruise control system, for example, Dynamic Laser Cruise Control provides an expected reference position relative to a target.

176. Toyota's Dynamic Laser Cruise Control sets the distance to maintain from the vehicle in front of the Toyota vehicle.

177. Toyota's Dynamic Laser Cruise Control allows a user to select from three distance settings (e.g. long (approximately 245 feet), medium (approximately 165 feet), and short (approximately 100 feet) while driving at 55 miles per hour).

178. For example, a 2009 Toyota press release on Dynamic Laser Cruise Control (available at https://pressroom.toyota.com/article_download.cfm?article_id=2604) provides the following (annotations added):

DLCC has two cruise control modes: constant speed and vehicle-to-vehicle control. The cruise control switch is used for switching between the two modes. Cruise control in the constant speed mode is identical to a conventional type cruise control system. The DLCC starts in the vehicle-to-vehicle control mode, which immediately recognizes and determines the lane in which the driver and the vehicle ahead are traveling. This enables the system to help maintain the pre-set vehicle-to-vehicle distance in accordance with the speed of the vehicle ahead.

...
In deceleration control mode, the ECM slows the vehicle using throttle and brake control so the vehicle-to-vehicle distance with the preceding vehicle equals the set distance. The distance settings are: long (approximately 245 feet), medium (approximately 165 feet), and short (approximately 100 feet) while traveling at 55 miles per hour. If the deceleration rate is more than a predetermined value, the Vehicle's Stability Control (VSC) ECU will activate the rear brake lights to inform the driver behind of the vehicle's deceleration.

In the following-control mode, the ECM helps maintain the pre-set vehicle-to-vehicle distance by matching the speed of the vehicle ahead, and regulating the throttle.

179. Toyota's Dynamic Laser Cruise Control generates a carrier position and attitude relative to the target vehicle (i.e. the vehicle in front of the Toyota vehicle) by a Range and Intensity Images Provider.

180. Toyota's Dynamic Laser Cruise Control monitors the Toyota vehicle's position and attitude relative to the vehicle in front of the Toyota vehicle based on a laser sensor that is made up of a laser emitting component, a laser receiving component, and a Central Processing Unit (CPU).

181. For example, a 2009 Toyota press release on Dynamic Laser Cruise Control (available at https://pressroom.toyota.com/article_download.cfm?article_id=2604) provides the following (annotations added):

Dynamic Laser Cruise Control (DLCC) is offered in select Toyota and Lexus models, taking cruise control systems to the next level. Using the latest Toyota technology, the DLCC system is designed to help control the distance between the vehicle and the traveling vehicle ahead based on the driving lanes, the vehicle traveling ahead, and vehicle speed.

...
The vehicle-to-vehicle distance control mode is controlled by a laser sensor and distance control Electronic Control Unit (ECU). The laser sensor is made up of the laser emitting component, laser receiving component, and the Central Processing Unit (CPU).

The laser emitting component radiates laser beams forward while the laser receiving component uses the reflected beams for detecting the presence of a preceding vehicle as well as measuring the vehicle-to-vehicle distance. The laser emits beams 16 degrees horizontally and four degrees vertically. The detection range of the sensor is approximately 400 feet ahead. The CPU will not react to non-moving objects.

The CPU calculates the vehicle-to-vehicle distance and the relative speed, transmitting this information to the distance control ECU. The signals are first sent to the ECM for data processing and then to the actuators.

182. The laser emitting component radiates laser beams forward while the laser receiving component uses the reflected beams for detecting the presence of a preceding vehicle as well as measuring the vehicle-to-vehicle distance.

183. For example, a Toyota Dynamic Laser Cruise Control System Quick Training Guide – QT512A (available at <https://www.manualslib.com/manual/1271625/Toyota-Dynamic-Laser-Cruise-Control-System.html>) provides the following information (annotation added):

Main Components

The following information explains general operation of the dynamic laser cruise control sensor and covers the key points of laser sensor adjustment.

How the laser sensor works:

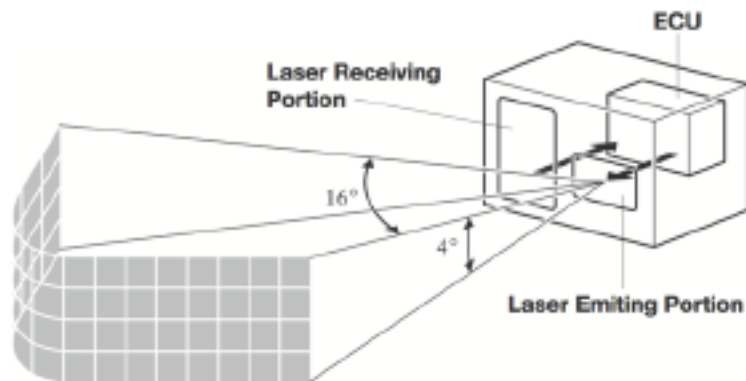

- The laser sensor emits a laser beam toward the preceding vehicle.
- The laser sensor receiving portion detects the light reflected from the preceding vehicle.
- The ECU inside the laser sensor then takes the light received by the sensor and converts it into an electrical signal.
- From this electrical signal, the preceding vehicle's distance and angle can be determined.

184. The CPU calculates the vehicle-to-vehicle distance and angle (and, therefore, attitude) and the relative speed.

185. Toyota's Dynamic Laser Cruise Control produces a relative position and attitude error.

186. Toyota's Dynamic Laser Cruise Control generates Range and Intensity Images as shown in the figure depicted in paragraph 182 with a matrix of sensed values (e.g., image) that correspond to the light (e.g., intensity) reflected from the preceding vehicle, which is then correlated to the preceding vehicle's distance (range).

187. If the relative position (e.g. carrier position relative to the vehicle in front) is different than the reference position (e.g. the set distance), the Dynamic Laser Cruise Control adapts to maintain the pre-set distance.

188. For example, a 2009 Toyota press release on Dynamic Laser Cruise Control (available at https://pressroom.toyota.com/article_download.cfm?article_id=2604) provides the following (annotations added):

DYNAMIC LASER CRUISE CONTROL

Dynamic Laser Cruise Control (DLCC) is offered in select Toyota and Lexus models, taking cruise control systems to the next level. Using the latest Toyota technology, the DLCC system is designed to help control the distance between the vehicle and the traveling vehicle ahead based on the driving lanes, the vehicle traveling ahead, and vehicle speed.

DLCC has two cruise control modes: constant speed and vehicle-to-vehicle control. The cruise control switch is used for switching between the two modes. Cruise control in the constant speed mode is identical to a conventional type cruise control system. The DLCC starts in the vehicle-to-vehicle control mode, which immediately recognizes and determines the lane in which the driver and the vehicle ahead are traveling. This enables the system to help maintain the pre-set vehicle-to-vehicle distance in accordance with the speed of the vehicle ahead.

189. Toyota's Dynamic Laser Cruise Control produces control commands for the relative position and attitude error for relative motion dynamics.

190. For example, Toyota's Dynamic Laser Cruise Control adjusts the following distance based on the distance setting and the Toyota vehicle's speed relative to the vehicle in front.

191. The signals from the laser sensor CPU are sent to a Electronic Control Module (ECM) for data processing and then sent to the actuators.

192. For example, in deceleration control mode, the ECM slows the Toyota vehicle using throttle and brake control so that the vehicle-to-vehicle distance with the preceding vehicle equals the set distance.

193. As another example, in following-control mode, the ECM maintains the pre-set vehicle-to-vehicle distance by matching the speed of the vehicle ahead, and regulating the throttle.

194. For example, a 2009 Toyota press release on Dynamic Laser Cruise Control (available at https://pressroom.toyota.com/article_download.cfm?article_id=2604) provides the following (annotations added):

DLCC has two cruise control modes: constant speed and vehicle-to-vehicle control. The cruise control switch is used for switching between the two modes. Cruise control in the constant speed mode is identical to a conventional type cruise control system. The DLCC starts in the vehicle-to-vehicle control mode, which immediately recognizes and determines the lane in which the driver and the vehicle ahead are traveling. This enables the system to help maintain the pre-set vehicle-to-vehicle distance in accordance with the speed of the vehicle ahead.

...
The CPU calculates the vehicle-to-vehicle distance and the relative speed, transmitting this information to the distance control ECU. The signals are first sent to the ECM for data processing and then to the actuators.
...

In deceleration control mode, the ECM slows the vehicle using throttle and brake control so the vehicle-to-vehicle distance with the preceding vehicle equals the set distance. The distance settings are: long (approximately 245 feet), medium (approximately 165 feet), and short (approximately 100 feet) while traveling at 55 miles per hour. If the deceleration rate is more than a predetermined value, the Vehicle's Stability Control (VSC) ECU will activate the rear brake lights to inform the driver behind of the vehicle's deceleration.

In the following-control mode, the ECM helps maintain the pre-set vehicle-to-vehicle distance by matching the speed of the vehicle ahead, and regulating the throttle.

195. Direct infringement of claim 1 of the '871 Patent occurs whenever the Dynamic Laser Cruise Control is active while the Accused Toyota Cruise Products are used.

196. Toyota directly infringes claim 1 of the '871 Patent by making, selling, and importing the Accused Toyota Cruise Products which, by design, practice the claimed process.

197. In addition, Toyota directly infringes claim 1 of the '871 Patent under 35 U.S.C. § 271(a) by using the Accused Toyota Cruise Products, including in relation to product demonstrating and testing.

198. In the alternative, to the extent that any steps of the method covered by claim 1 of the '871 patent are performed by third-parties, such as Toyota's customers (e.g., dealers) or users

of the Accused Toyota Cruise Products (e.g., customers who purchased a Toyota vehicle), Toyota induces infringement of claim 1 of the '871 Patent including by distributing the Accused Toyota Cruise Products that practice the claimed process in ordinary use. Toyota's technical design of its cruise control systems dictates that they will be used to infringe the claim. The Accused Toyota Cruise Products' cruise control system is infringing when customers operate the Accused Toyota Cruise Products' cruise control system. Toyota actively induces customers and end-users to directly infringe each and every claim limitation of at least claim 1 of the '871 Patent under 35 U.S.C. § 271(b).

199. In the alternative, Toyota induces infringement of claim 1 of the '871 Patent by end users including by distributing the Accused Toyota Cruise Products that practice the claimed process in ordinary use.

200. The Accused Toyota Cruise Products' cruise control system is active, at least some of the time, whenever Toyota or its customers operate the Accused Toyota Cruise Products.

201. Toyota has had actual knowledge of the '871 Patent since at least November 3, 2016 and AGNC's allegations of how the Accused Toyota Cruise Products infringe claim 1 of the '871 Patent since at least March 15, 2018.

202. Toyota has been and is knowingly inducing its customers and/or end users to directly infringe at least claim 1 of the '871 Patent with the specific intent to encourage such infringement, and knowing that the acts induced constitute patent infringement. Toyota's inducement includes, for example, encouraging consumers to purchase the Accused Toyota Cruise Products, and by providing, for example, technical guides, owner manuals, product data sheets, demonstrations, and other forms of support to dealers that induce them and its customers and/or

end users to directly infringe claim 1 of the '871 Patent by using the Accused Toyota Cruise Products' Dynamic Laser Cruise Control.

COUNT IV: INFRINGEMENT OF PAT. 6,480,789 CLAIM 22

203. AGNC reasserts and realleges paragraphs 1 through 70, of this Complaint as though set forth fully here.

204. Claim 22 of the '789 Patent provides:

Preamble to Claim 22	A positioning and proximity warning system for obtain collision avoidance with near objects, comprising
Element A	a navigation provider providing position data of a vehicle;
Element B	an object detection system providing position and dynamic data of near objects; and
Element C	an object tracking and collision avoidance processor receiving a vehicle performance and configuration data from an onboard vehicle control and management system, position data of said vehicle, and position and dynamic data of said near objects to provide an optimal proximity warning information.

205. Toyota makes, uses, sells, offers for sale, and imports vehicles that include a positioning and proximity warning system for obtaining collision avoidance with near objects (“Accused Toyota Collision Products”). The Accused Toyota Collision Products that infringe the system claimed in the '789 Patent include Toyota and Lexus vehicles sold after March 15, 2018 that feature either Toyota Safety Sense (“TSS”) (either TSS-C, TSS-P, or TSS 2.0) or Lexus Safety System (“LSS”) (either LSS+ or LSS+ 2.0) including, but not limited to these example vehicles: Toyota Avalon, Avalon Hybrid, Camry, Camry Hybrid, Corolla, Corolla Hybrid, Corolla Hatchback, C-HR, Highlander, Highlander Hybrid, Land Cruiser, Mirai, Prius, Prius Prime, Prius C, RAV4, RAV4 Hybrid, Sequoia, Sienna, Tacoma, Tundra, Yaris Liftback; Lexus IS, GS, GS F, LS, LSh, NX, NXh, RX, RXh, LX, RC, RC F, LC, LCh, ES, ESh, UX, UXh.

206. TSS-C features Pre-Collision System (PCS) and Lane Departure Assist (LDA).

207. TSS-P features PCS, LDA, and Dynamic Radar Cruise Control (DRCC).

208. TSS 2.0 features PCS, LDA, DRCC, and Lane Tracing Assist (LTA).

209. LSS+ features PCS, LDA, DRCC, and Lane Keep Assist (LKA).

210. LSS+ 2.0 features PCS, LDA, DRCC, and LTA.

211. Toyota has made and continues to make, use, sell, import, and/or offer for sale the Accused Toyota Collision Products, which meet each and every element of claim 22 of the '789 Patent.

212. The Accused Toyota Collision Products have a positioning and proximity warning system (e.g. TSS-C, TSS-P, TSS 2.0, LSS+ or LSS+ 2.0) for obtaining collision avoidance with near objects.

213. The Accused Toyota Collision Products' TSS or LSS+ system has a navigation provider that provides position data of the Toyota or Lexus vehicle.

214. For example, both LDA and LTA provide position data of the vehicle.

215. For example, LDA determines when the vehicle is deviating from the marked lane and alerts the driver.

216. The Toyota Safety Sense 2.0 Brochure (available at https://www.toyota.com/content/ebrochure/CFA_TSS_2.pdf) states:

LANE DEPARTURE ALERT (LDA)



LDA³ is designed to use the vehicle's forward-facing camera to detect lane departure when traveling on **relatively straight roads with clear lane markings, road edges or curbs**. The system's current operating status is indicated through colored lane marking illustrations on the vehicle's Multi-Information Display (MID). If LDA determines that the vehicle is starting to unintentionally deviate from its visibly marked lane, the system alerts the driver with an **audio and visual alert**. When this alert occurs, drivers must carefully check the surrounding road before safely directing the vehicle back to the center of the lane.

Steering Assist

In addition to the alert function, TSS 2.0¹ vehicles equipped with Electronic Power Steering (EPS) also include Steering Assist¹². When this functionality is enabled and LDA senses that the vehicle is unintentionally drifting from its lane, the system may **automatically make small corrective steering inputs** to help the driver keep the vehicle in its lane.

Road Edge Detection

For TSS 2.0¹, LDA³ has been updated with Road Edge Detection, which may be capable of **sensing the boundary between the road surface and the side of the road**.

217. As another example, LTA monitors the vehicle's position relative to lane markings and is designed to automatically make constant steering inputs to help keep the vehicle centered in its lane.

218. The Accused Toyota Collision Products' TSS or LSS+ system has an object detection system that provides position and dynamic data of near objects.

219. For example, both DRCC and PCS provide position and dynamic data of near objects.

220. For example, DRCC measures the position of a preceding vehicle (e.g. distance in front of the Toyota vehicle).

221. DRCC also measures dynamic data such as the speed of the preceding vehicle (the vehicle in front of the Toyota vehicle).

222. For example, the Toyota Safety Sense 2.0 Brochure (available at https://www.toyota.com/content/ebrochure/CFA_TSS_2.pdf) provides:

DYNAMIC RADAR CRUISE CONTROL (DRCC)

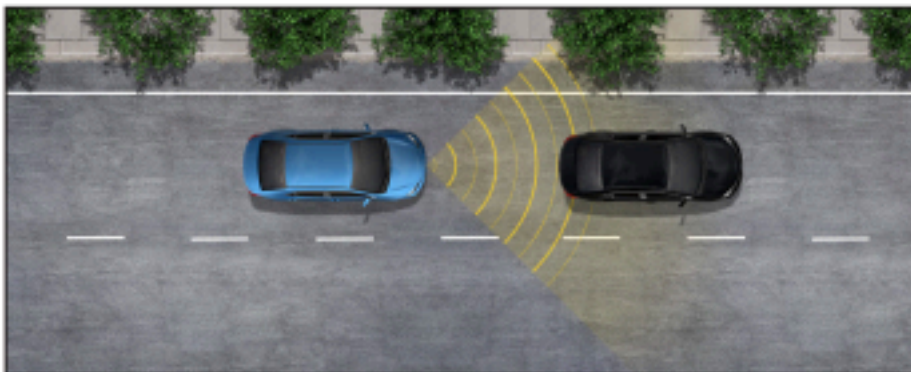

DRCC⁵ is a high-tech cruise control system that uses a front grille-mounted radar and a forward-facing camera to detect vehicles in front of you and automatically adjust the vehicle's speed to help maintain a pre-set distance behind a vehicle ahead.

Intended for highways, and similar to "constant speed" cruise control, DRCC⁵ lets drivers maintain a set speed without constant throttle input from the driver. DRCC goes a step further, however, by including a vehicle-to-vehicle distance control system, which adjusts the vehicle speed to help maintain a pre-set distance from vehicles ahead.

This means that if the vehicle ahead is detected traveling at a slower speed than your pre-set speed, DRCC will **automatically slow the vehicle** to maintain a pre-set following distance without deactivating cruise control. If DRCC determines the vehicle needs to slow down even more, an **audio and visual alert** occurs and **brakes may be applied**. When there's no longer a preceding vehicle driving slower than your set speed, DRCC will **accelerate back to your set speed**.

Most TSS 2.0 models will feature **Full-Speed Range Dynamic Radar Cruise Control⁵**, which is designed to allow low-speed following, speed matching, stopping, and acceleration/deceleration to a preceding vehicle.

223. For example, if the vehicle ahead is detected by DRCC as traveling at a slower speed than the Toyota vehicle's pre-set speed, DRCC will automatically slow the vehicle to maintain a pre-set following distance.

224. As another example, PCS measures the position and dynamic data of objects in front of the Toyota vehicle to help mitigate or avoid a frontal collision.

225. For example, when PCS determines that the possibility of a frontal collision with another vehicle is high, it prompts the driver to take evasive action and brake. And if the driver does not brake in a set time and the system determines that the possibility of a frontal collision with another vehicle is extremely high, the system may automatically apply the brakes, reducing the speed to help mitigate the impact or avoid the collision.

226. The Accused Toyota Collision Products' TSS or LSS+ system has an object tracking and collision avoidance processor that receives a vehicle performance and configuration data from an onboard vehicle control and management system, position data of the vehicle, and position and dynamic data of the near objects (such as the vehicle in front of the Toyota vehicle) to provide optimal proximity warning information.

227. For example, the TSS or LSS+ system receives the speed of the Toyota vehicle.

228. For example, the TSS or LSS+ system receives the pre-set distance and speed data from the DRCC user inputs.

229. For example, the TSS or LSS+ system receives the position of the Toyota vehicle from LDA or LTA, for example, which provide the position of the Toyota vehicle with respect to the lane markings.

230. For example, the TSS or LSS+ system receives position (e.g. vehicle-to-vehicle distance) and dynamic data (e.g. speed of the vehicle in front) of other vehicles from DRCC or PCS.

231. With the data, the TSS or LSS+ system provides proximity warning information such as audio and visual alerts.

232. For example, the Toyota Safety Sense 2.0 Brochure (available at https://www.toyota.com/content/ebrochure/CFA_TSS_2.pdf) provides (emphasis added):

DYNAMIC RADAR CRUISE CONTROL (DRCC)

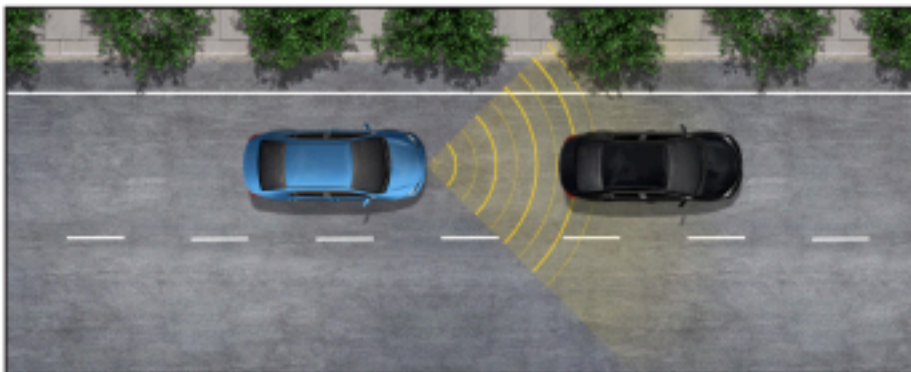

DRCC⁵ is a high-tech cruise control system that uses a front grille-mounted radar and a forward-facing camera to detect vehicles in front of you and automatically adjust the vehicle's speed to help maintain a pre-set distance behind a vehicle ahead.

Intended for highways, and similar to "constant speed" cruise control, DRCC⁵ lets drivers maintain a set speed without constant throttle input from the driver. DRCC goes a step further, however, by including a vehicle-to-vehicle distance control system, which adjusts the vehicle speed to help maintain a pre-set distance from vehicles ahead.

This means that if the vehicle ahead is detected traveling at a slower speed than your pre-set speed, DRCC will **automatically slow the vehicle** to maintain a pre-set following distance without deactivating cruise control. If DRCC determines the vehicle needs to slow down even more, an **audio and visual alert** occurs and **brakes may be applied**. When there's no longer a preceding vehicle driving slower than your set speed, DRCC will **accelerate back to your set speed**.

Most TSS 2.0 models will feature **Full-Speed Range Dynamic Radar Cruise Control⁵**, which is designed to allow low-speed following, speed matching, stopping, and acceleration/deceleration to a preceding vehicle.

LANE DEPARTURE ALERT (LDA)

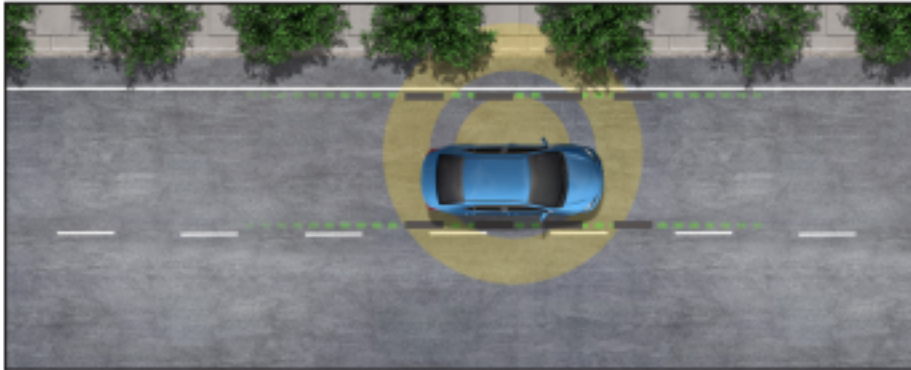

LDA³ is designed to use the vehicle's forward-facing camera to detect lane departure when traveling on **relatively straight roads with clear lane markings, road edges or curbs**. The system's current operating status is indicated through **colored lane marking illustrations on the vehicle's Multi-Information Display (MID)**. If LDA determines that the vehicle is starting to unintentionally deviate from its visibly marked lane, the system alerts the driver with an **audio and visual alert**. When this alert occurs, drivers must carefully check the surrounding road before safely directing the vehicle back to the center of the lane.

233. Direct infringement of claim 22 occurs when Toyota makes, imports, uses, sells, and/or offers for sale the Accused Toyota Collision Products that meet claim 22 of the '789 Patent.

234. Toyota has knowledge of the '789 Patent since at least August 23, 2006 and AGNC's allegations of how the Accused Toyota Collision Products infringe claim 22 of the '789 Patent since at least March 15, 2018.

235. Toyota has made, makes, uses, offers to sell, sells, and/or imports the Accused Toyota Collision Products knowing that the Accused Toyota Collision Products infringe claim 22 of the '789 Patent.

WILLFUL INFRINGEMENT

236. Toyota has infringed and continues to infringe the above identified claims of each of the Patents-in-Suit despite its knowledge of the Patents-in-Suit, knowledge of how its accused systems infringe the Patents-in-Suit since at least March 15, 2018 and the objectively high likelihood that its actions constitute patent infringement.

237. Toyota's infringement of the Patents-in-Suit is willful and deliberate, entitling AGNC to enhanced damages under 35 U.S.C. §284 and to attorneys' fees and costs incurred in prosecuting this action under 35 U.S.C. §285.

JURY DEMAND

AGNC demands a trial by jury on all issues that may be so tried.

REQUEST FOR RELIEF

WHEREFORE, Plaintiff AGNC requests that this Court enter judgment in its favor and against Defendants Toyota Motor Corporation, Toyota Motor North America, Inc., Toyota Motor Sales, U.S.A., Inc., and Toyota Motor Engineering & Manufacturing North America, Inc. as follows:

- A. Adjudging, finding, and declaring that Toyota has infringed the above-identified claims of each of the Patents-in-Suit under 35 U.S.C. § 271;
- B. Awarding the past and future damages arising out of Toyota's infringement of the Patents-in-Suit to AGNC in an amount no less than a reasonable royalty, together with prejudgment and post-judgment interest, in an amount according to proof;
- C. Adjudging, finding, and declaring that Toyota's infringement is willful and awarding enhanced damages and fees as a result of that willfulness under 35 U.S.C. § 284;

- D. Adjudging, finding, and declaring that the Patents-in-Suit are valid and enforceable;
- E. Awarding attorney's fees, costs, or other damages pursuant to 35 U.S.C. §§ 284 or 285 or as otherwise permitted by law; and
- F. Granting AGNC such other further relief as is just and proper, or as the Court deems appropriate.

Dated: May 14, 2019

Respectfully submitted,

/s/ Alison Aubry Richards

David Berten
IL Bar # 6200898
dberten@giplg.com
Alison Aubry Richards
IL Bar # 6285669 (*also admitted in ED Texas*)
arichards@giplg.com
Alexander Debski
IL Bar # 6305715(*also admitted in ED Texas*)
adebski@giplg.com
Global IP Law Group, LLC
55 West Monroe Street
Suite 3400
Chicago, IL 60603
T: (312) 241-1500
F: (312) 241-1522

*Attorneys for Plaintiff American GNC
Corporation*