

1 QUINN EMANUEL URQUHART & SULLIVAN, LLP  
 2 James R. Asperger (Bar No. 83188)  
 3 jamesasperger@quinnemanuel.com  
 4 Yury Kapgan (Bar No. 218366)  
 5 yurykapgan@quinnemanuel.com  
 6 865 S. Figueroa Street, 10th Floor  
 7 Los Angeles, CA 90017  
 8 Telephone: (213) 443-3000  
 9 Facsimile: (213) 443-3100  
 10 Victoria F. Maroulis (Bar No. 202603)  
 11 victoriamaroulis@quinnemanuel.com  
 12 555 Twin Dolphin Drive, 5th Floor  
 13 Redwood Shores, CA 94065  
 14 Telephone: (650) 801-5000  
 15 Facsimile: (650) 801-5100

Jordan R. Jaffe (Bar No. 254886)  
 jordanjaffe@quinnemanuel.com  
 50 California Street, 22nd Floor  
 San Francisco, CA 94111  
 Telephone: (415) 875-6600  
 Facsimile: (415) 875-6700

BLACKBERRY CORPORATION  
 Edward R. McGah, Jr (Bar No. 97719)  
 Vice President, Deputy General  
 Counsel – Litigation  
 41 Ticknor Place  
 Laguna Niguel, California 92677  
 Telephone: (650) 581-4750

11 Attorneys for Plaintiff  
 12 BlackBerry Limited

13 IN THE UNITED STATES DISTRICT COURT  
 14 FOR THE CENTRAL DISTRICT OF CALIFORNIA  
 15

16 BLACKBERRY LIMITED, a  
 17 Canadian corporation,

18 Plaintiff,

19 v.

20 TWITTER, INC., a Delaware  
 21 corporation

22 Defendant.  
 23  
 24  
 25  
 26  
 27  
 28

CASE NO. 2:19-cv-1444-GW (KSx)

**FIRST AMENDED COMPLAINT  
 FOR PATENT INFRINGEMENT**

**JURY TRIAL DEMANDED**

1                    **FIRST AMENDED COMPLAINT FOR PATENT INFRINGEMENT**

2                    Plaintiff BlackBerry Limited (“BlackBerry” or “Plaintiff”) hereby asserts the  
3 following claims for patent infringement against Defendant Twitter, Inc. (“Twitter”  
4 or “Defendant”), and alleges as follows:

5    **SUMMARY**

6                    1.        ***BlackBerry Pioneers Mobile Messaging*** - BlackBerry has been a  
7 leading innovator in the field of mobile communications for the past 30 years,  
8 having invested substantial sums into research and development of communications  
9 technologies. BlackBerry’s innovations led to the commercialization of some of the  
10 earliest models of smartphones in the United States, enabling its users to, among  
11 other things, send and receive e-mails securely and surf the internet anytime and  
12 anywhere. These same innovations prompted the rise of the smartphone as a  
13 necessary everyday accessory for businesspersons and ordinary consumers alike.

14                    2.        One example of BlackBerry’s innovations is the BlackBerry Messenger  
15 technology, which revolutionized instant messaging by providing users with secure,  
16 user-friendly, point-to-point instant messaging on their mobile devices. In many  
17 respects, through BlackBerry Messenger and other research and development,  
18 BlackBerry helped pioneer modern mobile messaging—secure, instant and user  
19 friendly on a mobile device. The appeal and success of BlackBerry Messenger led  
20 consumers to consider instant messaging functionality as an integral aspect of  
21 mobile communications, resulting today in billions of people worldwide engaging in  
22 instant messaging over their mobile devices.

23                    3.        As an innovator, BlackBerry took many steps to safeguard this valuable  
24 intellectual property. It received numerous patents protecting the cutting-edge  
25 features of its mobile phones, BlackBerry Messenger, and other communications  
26 applications that make such products secure, easy-to-use, and ultimately engaging to  
27 the end-user, thereby driving user growth and retention.

28

1           4.     ***Defendant Later Develops Competing Applications that Improperly***  
2 ***Use BlackBerry's Mobile Messaging Intellectual Property*** - Defendant, on the  
3 other hand, is a relative latecomer to the mobile messaging world. Defendant  
4 created mobile messaging applications that co-opt BlackBerry's innovations, using a  
5 number of the innovative user interface and functionality enhancing features that  
6 made BlackBerry's products such a critical and commercial success in the first  
7 place.

8           5.     The Patents-in-Suit cover, for example:

9           (a) ***User Interface Improvements For Mobile Devices***—including (i)  
10 improvements in message notification techniques that streamline and  
11 optimize reception of new message notifications that prevent users from being  
12 inundated with numerous messaging notifications, (ii) resetting a new  
13 message indicator when a user accesses their inbox list of messaging  
14 conversations, which saves users from having to individually view each  
15 conversation in which there is a new message in order to reset their new  
16 message indicator;

17           (b) ***Messaging and Social Networking Improvements for Mobile Devices***—  
18 including (i) improved techniques for determining whether a recipient has  
19 read messages in a conversation by inferring the status of one or more of the  
20 messages, thereby reducing data transmissions, power consumption and  
21 improving battery life in mobile devices, (ii) improved techniques for making  
22 informational content, selected by one user, available to one or more other  
23 users via a data hub server that avoids users having to download and re-  
24 upload content that they wish to share, thereby reducing unnecessary data  
25 transmissions, power consumption and improving battery life in mobile  
26 devices, and (iii) improving engagement in social networking platforms by  
27 selectively adjusting notification of social media messages containing certain  
28

1 content, such as rapidly spreading misinformation or untruthful, derogatory or  
2 defamatory statements, and other undesirable or offensive content; and

3 (c) *Mobile Advertising*—improved techniques of delivering targeted  
4 advertising and content to mobile devices based on user demographics and  
5 interest, as well as the location of the user’s mobile device and time-based  
6 triggers.

7 6. *Defendant’s Use of BlackBerry’s Mobile Messaging Innovations*  
8 *Harms BlackBerry and Provides an Undeserved Windfall to Defendant*—

9 Defendant’s use of BlackBerry’s inventions, and infringement of the Patents-in-Suit,  
10 has succeeded in diverting consumers away from BlackBerry’s products and  
11 services and toward those of Defendant. This has resulted in a substantial and  
12 undeserved windfall for Defendant as these users drive Defendant’s revenue.  
13 Defendant’s gain comes at BlackBerry’s expense, depriving BlackBerry of revenue  
14 to which it is entitled as a result of its inventions.

15 7. BlackBerry attempted to resolve this dispute without resorting to  
16 litigation. For example, Blackberry reached out to Defendant’s General Counsel in  
17 June and July 2017 regarding BlackBerry’s patent portfolio and, among other  
18 things, identified two of the Patents-in-Suit as being infringed by Defendant. *See*  
19 *Ex. I*, attached hereto. However, Defendant has refused to adequately compensate  
20 BlackBerry for its use of BlackBerry’s intellectual property. Through this suit,  
21 BlackBerry seeks redress for the harm caused by Defendant’s unlawful use of  
22 BlackBerry’s intellectual property.

23 **INTRODUCTION TO BLACKBERRY**

24 8. For more than 30 years, BlackBerry has been a leading innovator in the  
25 mobile communications industry. BlackBerry’s cutting-edge wireless  
26 communication products and services have transformed the way people around the  
27 world connect, converse, and share digital information.

28

1           9. BlackBerry was founded in 1984 in Waterloo, Ontario by two  
2 engineering students, Mike Lazaridis and Douglas Fregin. In its early years, the  
3 company—then named Research In Motion (“RIM”)—focused its inventive  
4 energies on wireless data transmission.

5           10. From its modest beginnings more than 30 years ago, BlackBerry has  
6 gone on to offer a portfolio of award-winning products, services, and embedded  
7 technologies to tens of millions of individual consumers and organizations around  
8 the world, including governments, and educational institutions. By transforming the  
9 way people communicate, BlackBerry laid a foundation for today’s multibillion-  
10 dollar modern smartphone industry. BlackBerry’s innovations in mobile  
11 communications continue to this day through BlackBerry’s award-winning software  
12 platform and devices, which enable and manage security, mobility, and  
13 communications between and among hardware, programs, mobile applications, and  
14 the Internet of Things (IoT).

15           11. In the course of developing its ground-breaking mobile  
16 communications systems, BlackBerry (and the BlackBerry family of companies)  
17 invented a broad array of technologies that cover everything from enhanced security  
18 and cryptographic techniques, to mobile device user interfaces, instant messaging  
19 functionality, communication servers, and many other areas. To take just one  
20 example, security posed a critical challenge for BlackBerry to address when  
21 bringing its mobile devices to market. Commercial acceptance of such mobile  
22 devices required providing mechanisms to ensure safe and secure communications  
23 so that users and businesses could be confident that their confidential and private  
24 information stayed that way in the face of ever-increasing security threats. As a  
25 result of its innovative technologies, BlackBerry has been universally recognized as  
26 the gold standard when it comes to safe and secure data communications over  
27 mobile devices.

28

1 12. Indeed, throughout its history, BlackBerry has demonstrated a  
2 commitment to innovation, including through its investments in research and  
3 development, which have totaled more than \$5.5 billion over the past decade.  
4 BlackBerry has protected the technical innovations resulting from these investments,  
5 including by seeking patent protection, and as detailed below, BlackBerry owns  
6 rights to an array of patented technologies in the United States.

7 13. BlackBerry owns United States Patent Nos. 8,676,929, 8,296,351,  
8 9,349,120, 9,021,059, 8,286,089, 8,572,182, and 8,825,777 (collectively, the  
9 “Patents-in-Suit”). Defendant infringes the Patents-in-Suit by using, without  
10 authorization, BlackBerry’s proprietary technologies in a number of commercial  
11 products and services, such as Twitter, the Twitter application,<sup>1</sup> and Twitter Ads  
12 which are marketed, offered and distributed to advertisers and users of mobile and  
13 other devices throughout the United States, including in this District.

14 14. By this action, BlackBerry seeks to put an end to Defendant’s  
15 unauthorized use of BlackBerry’s patented technologies and to obtain compensation  
16 for the harm BlackBerry has suffered.

17 **NATURE OF THE ACTION**

18 15. This is a civil action for patent infringement under the patent laws of  
19 the United States, 35 U.S.C. § 1 *et seq.*

20 16. Defendant has infringed and continues to infringe, and has induced and  
21 continues to induce infringement of, one or more claims of the Patents-in-Suit at  
22 least by making, using, selling, and/or offering to sell Twitter Ads and the Twitter  
23 application for mobile and other devices in the United States, including in this  
24 District.

25  
26 \_\_\_\_\_  
27 <sup>1</sup> As used herein, “Twitter application” refers to all applicable versions of the  
28 Twitter application, including those released for iOS, Android, Windows, and the  
web ([www.twitter.com](http://www.twitter.com)).

1 17. BlackBerry is the legal owner by assignment of the Patents-in-Suit,  
2 which were duly and legally issued by the United States Patent and Trademark  
3 Office (“USPTO”). BlackBerry seeks injunctive relief and monetary damages.

4 **THE PARTIES**

5 18. Plaintiff BlackBerry Limited is a Canadian company with its principal  
6 place of business at 2200 University Avenue East, Waterloo, Ontario, Canada N2K  
7 0A7. BlackBerry Limited is the owner of intellectual property rights at issue in this  
8 action.

9 19. On information and belief, Defendant is a Delaware corporation with a  
10 principal place of business at 1355 Market St. Ste. 900, San Francisco, CA 94103.  
11 On information and belief, Defendant maintains offices in Santa Monica, California,  
12 operates and owns the website located at [www.twitter.com](http://www.twitter.com), and markets, offers, and  
13 distributes applications and services such as Twitter and Twitter Ads throughout the  
14 United States, including in this District.

15 20. Upon information and belief, Defendant directly and/or indirectly  
16 develops, designs, manufactures, distributes, markets, offers to sell and/or sells  
17 infringing products and services in the United States, including in this District, and  
18 otherwise purposefully directs infringing activities to this District in connection with  
19 the Twitter application and Twitter Ads.

20 **JURISDICTION AND VENUE**

21 21. This is a civil action for patent infringement arising under the patent  
22 laws of the United States, 35 U.S.C. § 1 *et seq.*

23 22. This Court has subject matter jurisdiction over the matters asserted  
24 herein under 28 U.S.C. §§ 1331 and 1338(a) and 35 U.S.C. §§ 271 *et seq.*

25 23. This Court has personal jurisdiction over Defendant, in part because  
26 Defendant does continuous and systematic business in this District, including by  
27 providing infringing products and services to the residents of this District that it  
28 knew would be used within this District, and by soliciting business from the

1 residents of this District. For example, Defendant is subject to personal jurisdiction  
2 in this Court because, among other reasons, upon information and belief, it has a  
3 regular and established place of business at its offices in this District, including its  
4 office in Santa Monica (*see* [https://careers.twitter.com/en/locations/los-  
5 angeles.html](https://careers.twitter.com/en/locations/los-angeles.html)), employs over 80 individuals in the Los Angeles Metro Area (*see* Ex.  
6 H) and elsewhere in the State of California, and directly and through agents  
7 regularly does, solicits and transacts business in the Central District of California  
8 and elsewhere in the State of California, including through its website at  
9 [www.twitter.com](http://www.twitter.com), Twitter Ads, and its Twitter application, all of which are  
10 marketed, offered, and distributed to and utilized by advertisers and users of  
11 computing and mobile devices in this District and throughout the State of California.

12         24. In particular, Defendant has committed and continues to commit acts of  
13 infringement in violation of 35 U.S.C. § 271, and has made, used, marketed,  
14 distributed, offered for sale, sold, and/or imported infringing products and services  
15 in the State of California, including in this District, and engaged in infringing  
16 conduct within and directed at or from this District. For example, Defendant has  
17 purposefully and voluntarily placed the Twitter application and Twitter Ads into the  
18 stream of commerce with the expectation that its infringing products and services  
19 will be used in this District. The infringing Twitter application and Twitter Ads  
20 have been and continue to be distributed to and used in this District. Defendant's  
21 acts cause injury to BlackBerry, including within this District.

22         25. Venue is proper in this District under the provisions of 28 U.S.C.  
23 §§ 1391 and 1400(b) at least because a substantial part of the events or omissions  
24 giving rise to the claims occurred in this judicial district, and because Defendant has  
25 committed acts of infringement in this District and has a regular and established  
26 place of business in this District.

27  
28



1 26. In particular, on information and belief, Defendant has a regular and  
2 established place of business in this District located in Santa Monica, California.<sup>2</sup>  
3 On further information and belief, Defendant employs engineers and/or other  
4 personnel within this District, including at its office in Santa Monica.<sup>3</sup>

### 5 FACTS COMMON TO ALL CLAIMS

#### 6 BlackBerry's Innovation and Industry Recognition

7 27. BlackBerry is a global leader in the mobile communications industry.  
8 Through its significant investment in research and development over the past 30  
9 years, BlackBerry has developed innovative, cutting-edge technologies that have  
10 changed the face of telecommunications. In particular, BlackBerry has developed  
11 key innovations in the way mobile devices and communications software interact  
12 with and receive input from users. BlackBerry's innovations in messaging and UI  
13 development improved the speed and accuracy with which users could perform  
14 various tasks on their mobile devices.

15 28. In the late 1990s, BlackBerry began to release a series of game-  
16 changing handheld mobile devices that enabled users to send and receive email and  
17 messages on the go, without needing to be tethered to a modem or a desktop  
18 computer. The innovative nature of the 1998 RIM 950 Wireless Handheld, for  
19 example, was instantly recognized, garnering both an Editor's Choice Award from  
20 CNET and Andrew Seybold's Outlook Award. In particular, the press praised the  
21 RIM 950's keyboard for its advanced ergonomic features, including an easy-to-type-  
22 on keyboard layout despite the device's miniature size.

23  
24 \_\_\_\_\_  
25 <sup>2</sup> See, e.g., <https://careers.twitter.com/en/locations/los-angeles.html>;  
26 <https://twitter.com/TwitterLA> (“Official Account for the tweeps in the #TwitterLA  
office!”).

27 <sup>3</sup> For example, [www.linkedin.com](http://www.linkedin.com) identifies more than 80 Twitter employees in the  
28 Greater Los Angeles Area. (See Ex. H.)

1           29. In 2002, BlackBerry released the BlackBerry 6710 and 6720 – the first  
2 BlackBerry devices capable of both sending emails and making phone calls, and  
3 some of the earliest smartphones released in the United States. The next year,  
4 BlackBerry introduced smartphone models that added built-in audio hardware and  
5 color screens. Since those early smartphones, BlackBerry has continued to offer  
6 handheld wireless products incorporating its proprietary technologies in security,  
7 communications, mobile device user interfaces, and other areas.

8           30. In 2005, BlackBerry introduced the innovative BlackBerry Messenger  
9 (or “BBM”) application, which revolutionized the concept of instant messaging.  
10 BBM provided the first form of point-to-point communications that was instant,  
11 cross-carrier, and mobile. The developers of BBM further incorporated a well-  
12 designed graphical user interface and other innovative features not utilized by  
13 messaging platforms at that time. For example, BBM has been credited as the first  
14 messaging platform to enable status updates showing when messages were  
15 Delivered and Read by users, which created a pioneering sense of real-time presence  
16 that is now standard in many instant messaging applications. Additionally, BBM’s  
17 unique platform has allowed users to communicate even when traditional forms of  
18 cell communication were incapacitated, such as during the Chilean earthquake in  
19 2010.<sup>4</sup>

20           31. Over the years, BlackBerry continued to develop and improve  
21 successive versions of BBM by introducing features such as GPS positioning,  
22 connected applications, voice chat, private chat, and many other features. As a  
23 result, BBM has been widely downloaded and is popular among users of all  
24 platforms, including Android and iOS. Indeed, more than 5 million people

25 \_\_\_\_\_  
26 <sup>4</sup> See, e.g., [https://www.cio.com/article/2420175/blackberry-phone/blackberry-](https://www.cio.com/article/2420175/blackberry-phone/blackberry-messenger--bbm--keeps-chilean-quake-affected-connected.html)  
27 [messenger--bbm--keeps-chilean-quake-affected-connected.html](http://www.nytimes.com/2001/09/20/technology/the-right-connections-the-simple-blackberry-allowed-contact-when-phones-failed.html);  
28 [http://www.nytimes.com/2001/09/20/technology/the-right-connections-the-simple-](http://www.nytimes.com/2001/09/20/technology/the-right-connections-the-simple-blackberry-allowed-contact-when-phones-failed.html)  
[blackberry-allowed-contact-when-phones-failed.html](http://www.nytimes.com/2001/09/20/technology/the-right-connections-the-simple-blackberry-allowed-contact-when-phones-failed.html).

1 downloaded BBM within 8 hours of the release of its Android and iOS versions in  
2 October 2013. By March 4, 2015, the Android version of BBM had reached 100  
3 million Google Play installs. BBM also enjoys strong user loyalty, with studies  
4 finding that 82% of BBM’s Android users continue using the application 90 days  
5 after installation.

6 32. Each successive iteration of BlackBerry’s wireless devices and  
7 technologies have received significant unsolicited coverage in the media. For  
8 example, GSMA—the largest and most well-known association of mobile  
9 operators—recognized BlackBerry and its communication technologies as  
10 “chang[ing] the face of corporate communication.” Thomson Reuters named  
11 BlackBerry one of the World’s Top 100 Most Innovative Organizations, based  
12 largely on the number of “important patents” owned by BlackBerry. In 2015,  
13 Forrester Research crowned BlackBerry as a “leader in mobile management” based  
14 on BlackBerry’s focus in security software and mobile solutions.

15 33. BlackBerry’s handheld devices and communications technologies have  
16 garnered widespread industry acclaim for both their unique design and their  
17 performance. For example, BlackBerry mobile devices have garnered dozens of  
18 industry awards, including the GSMA Chairman’s Award, InfoWorld Magazine’s  
19 Product of the Year Award, PC World’s World Class Award, the Network Industry  
20 Award for Best New Mobile Communications Product, the BusinessWeek Best  
21 Product of the Year Award, Digit Magazine’s “World’s Best Mobile OS” Award,  
22 Security Products “Govies” Government Security Award, and PC Magazine’s Best  
23 Products of the Year Award. BBM in particular has been recognized for its  
24 innovations in mobile messaging, being awarded “Superstar” distinction from the  
25 2014 Mobile Star Awards in the Mobile Messaging or Email category, the Indonesia  
26 Golden Ring Award for Best Mobile Social Media, and the ICA 2014 Award for  
27 Best Mobile Chat App.

28

1 34. BlackBerry’s more recent innovations have garnered similar industry  
2 acclaim. For example, in 2015 BlackBerry’s Passport was awarded the prestigious  
3 Red Dot “Best of the Best” award for innovative product design (from thousands of  
4 total entries); BlackBerry and BBM were recognized with the Mobile Marketing  
5 Association’s “Smartie” Award for 2015 Publisher/Media Company of the Year in  
6 Mobile; and BlackBerry’s PRIV was awarded the Red Dot “Design Award” for best  
7 product design in 2016.

8 **BlackBerry’s Patents**

9 35. U.S. Patent No. 8,676,929 (“’929 Patent”) is entitled “System and  
10 method for pushing information to a mobile device,” and was issued on March 18,  
11 2014. A true and correct copy of the ’929 Patent is attached as Exhibit A.

12 36. The ’929 Patent was filed on September 13, 2012 as U.S. Patent  
13 Application No. 13/614,884 and claims priority to, *inter alia*, U.S. Provisional Appl.  
14 No. 60/307,265 filed July 23, 2001.

15 37. BlackBerry Limited is the owner of all rights, title, and interest in and  
16 to the ’929 Patent, with the full and exclusive right to bring suit to enforce the ’929  
17 Patent, including the right to recover for past infringement.

18 38. The ’929 Patent is valid and enforceable under United States Patent  
19 Laws.

20 39. U.S. Patent No. 8,296,351 (“’351 Patent”) is entitled “System and  
21 method for pushing information to a mobile device,” and was issued on October 23,  
22 2012. A true and correct copy of the ’351 Patent is attached as Exhibit B.

23 40. The ’351 Patent was filed on March 18, 2010 as U.S. Patent  
24 Application No. 12/726,405 and claims priority to, *inter alia*, U.S. Provisional Appl.  
25 No. 60/307,265 filed July 23, 2001.

26 41. BlackBerry Limited is the owner of all rights, title, and interest in and  
27 to the ’351 Patent, with the full and exclusive right to bring suit to enforce the ’351  
28 Patent, including the right to recover for past infringement.

1           42. The '351 Patent is valid and enforceable under United States Patent  
2 Laws.

3           43. U.S. Patent No. 9,349,120 ("'120 Patent") is entitled "System and  
4 method for silencing notifications for a message thread," and was issued on May 24,  
5 2016. A true and correct copy of the '120 Patent is attached as Exhibit C.

6           44. The '120 Patent was filed on Feb. 26, 2010 as U.S. Patent Application  
7 No. 12/713,577 and claims priority to U.S. Provisional Appl. No. 61/167,542 filed  
8 Apr. 8, 2009.

9           45. BlackBerry Limited is the owner of all rights, title, and interest in and  
10 to the '120 Patent, with the full and exclusive right to bring suit to enforce the '120  
11 Patent, including the right to recover for past infringement.

12           46. The '120 Patent is valid and enforceable under United States Patent  
13 Laws.

14           47. U.S. Patent No. 9,021,059 ("'059 Patent") is entitled "Data hub server,"  
15 and was issued on April 28, 2015. A true and correct copy of the '059 Patent is  
16 attached as Exhibit D.

17           48. The '059 Patent was filed on Nov. 21, 2011 as U.S. Patent Application  
18 No. 13/301,006 and is a continuation of U.S. Patent Application No. 112/394,994  
19 filed Feb. 27, 2009, which issued as U.S. Patent No. 8,065,361.

20           49. BlackBerry Limited is the owner of all rights, title, and interest in and  
21 to the '059 Patent, with the full and exclusive right to bring suit to enforce the '059  
22 Patent, including the right to recover for past infringement.

23           50. The '059 Patent is valid and enforceable under United States Patent  
24 Laws.

25           51. U.S. Patent No. 8,286,089 ("'089 Patent") is entitled "Representing  
26 new messages on a communication device," and was issued on October 9, 2012. A  
27 true and correct copy of the '089 Patent is attached as Exhibit E.  
28

1           52. The '089 Patent was filed on Dec. 30, 2005 as U.S. Patent Application  
2 No. 11/320,980.

3           53. BlackBerry Limited is the owner of all rights, title, and interest in and  
4 to the '089 Patent, with the full and exclusive right to bring suit to enforce the '089  
5 Patent, including the right to recover for past infringement.

6           54. The '089 Patent is valid and enforceable under United States Patent  
7 Laws.

8           55. U.S. Patent No. 8,572,182 ("182 Patent") is entitled "Handling  
9 notifications in instant messaging systems," and was issued on Oct. 29, 2013. A  
10 true and correct copy of the '182 Patent is attached as Exhibit F.

11           56. The '182 Patent was filed on July 21, 2006 as U.S. Patent Application  
12 No. 11/459,047.

13           57. BlackBerry Limited is the owner of all rights, title, and interest in and  
14 to the '182 Patent, with the full and exclusive right to bring suit to enforce the '182  
15 Patent, including the right to recover for past infringement.

16           58. The '182 Patent is valid and enforceable under United States Patent  
17 Laws.

18           59. U.S. Patent No. 8,825,777 ("777 Patent") is entitled "Selective  
19 delivery of social network messages within a social network," and was issued on  
20 September 2, 2014. A true and correct copy of the '777 Patent is attached as Exhibit  
21 G.

22           60. The '777 Patent was filed on Oct. 5, 2011 as U.S. Patent Application  
23 No. 13/253,252.

24           61. BlackBerry Limited is the owner of all rights, title, and interest in and  
25 to the '777 Patent, with the full and exclusive right to bring suit to enforce the '777  
26 Patent, including the right to recover for past infringement.

27           62. The '777 Patent is valid and enforceable under United States Patent  
28 Laws.

1                   **Defendant’s Use of BlackBerry’s Patented Technologies**

2           63. On information and belief, Defendant released its first mobile Twitter  
3 application in April 2010, nearly half a decade after BlackBerry’s release of  
4 BlackBerry Messenger (“BBM”).<sup>5</sup> Additionally, Defendant first introduced  
5 “Promoted Tweet” advertisements via Twitter Ads sometime in 2010, nearly a  
6 decade after the priority date of BlackBerry’s ’929 and ’351 patents.<sup>6</sup> Additionally,  
7 Defendant first introduced quality filters for selectively adjusting notification of  
8 Tweets sometime in 2016, nearly half a decade after the priority date of  
9 BlackBerry’s ’777 patent.<sup>7</sup>

10           64. By the time Defendant had released even the first (and simplest)  
11 version of its Twitter application, BlackBerry had already invented most of the  
12 technologically innovative messaging application functionalities at issue in this  
13 action. Industry commentators at the time noted the success of BBM, including  
14 with consumer audiences such as “[t]eens, for instance, [who] love BlackBerry  
15 Messenger, RIM’s proprietary instant messaging feature.” *See*  
16 [http://archive.fortune.com/2009/08/12/technology/blackberry\\_research\\_in\\_motion.f](http://archive.fortune.com/2009/08/12/technology/blackberry_research_in_motion.f)  
17 [ortune/index.htm](http://archive.fortune.com/2009/08/12/technology/blackberry_research_in_motion.f). The consumer demand and appreciation for BlackBerry’s  
18 innovative messaging application functionalities was further evidenced in 2013,  
19 when BlackBerry released the first versions of BBM for Apple’s iOS and Google’s  
20 Android mobile device platforms and recorded over 5 million downloads of BBM  
21 within the first 8 hours of being made available. *See*  
22 <https://9to5mac.com/2013/10/21/blackberry-announces-5-million-downloads-of->  
23

---

24 <sup>5</sup> *See, e.g.*, [https://blog.twitter.com/official/en\\_us/a/2010/twitter-for-iphone-1.html](https://blog.twitter.com/official/en_us/a/2010/twitter-for-iphone-1.html);  
25 <https://techcrunch.com/2010/04/09/twitter-acquires-tweetie/>.

26 <sup>6</sup> *See, e.g.*, [https://www.nytimes.com/2010/04/13/technology/internet/](https://www.nytimes.com/2010/04/13/technology/internet/13twitter.html)  
[13twitter.html](https://www.nytimes.com/2010/04/13/technology/internet/13twitter.html).

27 <sup>7</sup> *See, e.g.*, [https://techcrunch.com/2016/08/18/twitter-is-introducing-a-quality-](https://techcrunch.com/2016/08/18/twitter-is-introducing-a-quality-filter-to-clean-up-your-notifications-tab/)  
28 [filter-to-clean-up-your-notifications-tab/](https://techcrunch.com/2016/08/18/twitter-is-introducing-a-quality-filter-to-clean-up-your-notifications-tab/).

1 [bbm-for-ios-and-android-only-8-hours-after-release/](#). In just two years, BBM had  
2 been installed in over 100 million Android devices alone. *See*  
3 <http://blogs.blackberry.com/2015/03/bbm-hits-100m-google-play-installs/>.

4 65. Seizing on the success of BBM and demand for consumer messaging  
5 platforms featuring BlackBerry's innovative features and functionalities, Defendant  
6 has developed and released its infringing Twitter application that incorporates and  
7 unlawfully utilizes BlackBerry's patented technologies, including, without  
8 limitation, the Twitter application for Android and iOS devices. Likewise,  
9 Defendant has utilized BlackBerry's innovative electronic advertising technologies  
10 to monetize its Twitter platform, including without limitation, through its Twitter  
11 Ads service. Defendant has also utilized BlackBerry's innovative approach to  
12 managing electronic communications to address the spread of undesirable content in  
13 its social network to drive user growth, engagement, and retention, including  
14 without limitation, through its Twitter quality filter.

15 66. On information and belief, Defendant markets, offers, and distributes  
16 the infringing Twitter application and Twitter Ads service and makes, offers, and  
17 uses the infringing Twitter quality filters in and within the United States, including  
18 through distribution platforms such as the Apple iTunes App Store and the Google  
19 Android Play Store, the Microsoft Store, as well as its own websites,  
20 [www.twitter.com](http://www.twitter.com) and [business.twitter.com](http://business.twitter.com).

21 67. On information and belief, the accused Twitter application and Twitter  
22 Ads service are the primary or only products and services offered by Twitter in the  
23 United States.

24 68. On information and belief, Defendant encourages users of mobile and  
25 computing devices such as mobile phones and desktop and laptop computers in the  
26 United States to download and use the infringing Twitter application, and such users  
27 download and use the infringing application in the manner Defendant intends such  
28 application to be used. Moreover, Defendant encourages advertisers and businesses



1 in the United States to use the infringing Twitter Ads service, and such advertisers  
2 and businesses use the infringing service in the manner Defendant intends such  
3 service to be used.

4 69. On information and belief, Defendant has also designed, developed,  
5 tested, and used the infringing applications and services in and within the United  
6 States.

7 **COUNT I: INFRINGEMENT OF U.S. PATENT NO. 8,676,929**

8 70. BlackBerry incorporates by reference and re-alleges all of the foregoing  
9 paragraphs of this First Amended Complaint as if fully set forth herein.

10 **The '929 Patent**

11 71. The '929 Patent claims, among other things, “[a] server, comprising: a  
12 database organized into a plurality of memory location channels, each of the  
13 memory location channels storing information of a same category as a pre-defined  
14 category of each of the respective memory location channels, wherein upon  
15 detection of a triggering event comprising a time triggering event, determining the  
16 information relevant to the detected triggering event from among information stored  
17 in one of the plurality of memory location channels of the database, when the  
18 information relevant to the detected triggering event comprises content information,  
19 inserting into the content information a meta tag for one or more advertisements to  
20 be displayed with the content information that includes the meta tag to a mobile  
21 device, wherein the meta tag identifies the one or more advertisements and  
22 advertisement display requirements, and wherein the one or more advertisements are  
23 selected based on the detected triggering event.” ’929 Patent at claim 1.

24 **The Inventions Claimed in the '929 Patent Were Not**  
25 **Well-Understood, Routine, or Conventional**

26 72. The use of a server to detect a time triggering event, determine  
27 information relevant to the detected time triggering event, and insert a meta tag into  
28 content information corresponding to the detected time triggering event that

1 identifies one or more advertisements or advertisement display requirements  
2 selected based on the detected triggering event, was not common or conventional at  
3 the time of the '929 Patent.

4 73. The inventors of the '929 Patent recognized that when transmitting  
5 content triggered by, for example, a time triggering event, the insertion of a meta tag  
6 into content information could further facilitate the delivery of relevant and timely  
7 advertising information to mobile users. As taught by the '929 Patent, the disclosed  
8 invention “provides a method of combining the information so that the mobile  
9 device user has a consistent and transparent experience of receiving both  
10 information content and advertising content.” '929 Patent at 3:1-4.

11 74. Given the state of the art at the time of the invention of the '929 Patent,  
12 the inventive concepts of the '929 Patent were not conventional, well-understood, or  
13 routine. The '929 Patent discloses, among other things, an unconventional and  
14 technological solution to an issue arising specifically in the context of mobile  
15 communication devices, and the delivery of advertising content to such devices.  
16 The solution implemented by the '929 Patent provides a specific and substantial  
17 improvement over prior communication systems used for this purpose, resulting in  
18 an improved system for the delivery of relevant and timely content and advertising  
19 information to mobile device users. The '929 Patent achieves this result by  
20 introducing novel elements directed to improving the function and working of  
21 mobile communication systems such as, among other things, the claimed “a server”  
22 (all claims), positioned in a wireless network and configured according to the  
23 claims, the capability of the claimed server to detect a “time triggering event” and  
24 determine information relevant to the triggering event (all claims), and the capability  
25 of inserting into content information corresponding to the time triggering event a  
26 meta tag that identifies one or more advertisements and advertisement display  
27 requirements that are selected based on the time triggering event (all claims).

28

1 75. Consistent with the problem addressed being rooted in wireless  
2 communication to mobile devices, the '929 Patent's solutions are also rooted in the  
3 same technology that cannot be performed with pen and paper or in the human  
4 mind.

5 76. This technical context is reflected in the '929 Patent's claims. For  
6 example, the claims recite "a server" that detects a "time triggering event,"  
7 determines information relevant to the detected triggering event, and which  
8 transmits information over a "wireless network" to a "mobile device" with a "meta  
9 tag" that identifies the one or more advertisements and advertisement display  
10 requirements.

11 77. A person having ordinary skill in the art at the time of the inventions of  
12 the '929 Patent would not have understood that the inventions could or would be  
13 performed solely in the human mind or using pen and paper. Using pen and paper  
14 would ignore the stated purpose of the '929 Patent and the problem it was  
15 specifically designed to address, which arose in the context of needing an improved  
16 system for delivering content, including advertising content, from an information  
17 source to mobile users over a wireless network. Doing so would also run counter to  
18 the inventors' detailed description of the inventions and the language of the claims  
19 and be a practical impossibility.

#### 20 **'929 Patent Allegations**

21 78. Defendant has infringed and is infringing, either literally or under the  
22 doctrine of equivalents, the '929 Patent in violation of 35 U.S.C. § 271 *et seq.*,  
23 directly by making, using, selling, offering for sale, and/or importing into the United  
24 States without authority or license, the Twitter advertising platform including  
25 Twitter Ads, which transmits targeted advertisements to Twitter users, as well as  
26 associated backend servers and systems (hereinafter "the '929 Accused Products")  
27 that infringe at least claims 1, 9 and 10 of the '929 Patent. The '929 Accused  
28 Products are non-limiting examples identified based on publicly available

1 information, and BlackBerry reserves the right to identify additional infringing  
2 activities, products and services, including, for example, on the basis of information  
3 obtained during discovery.

4 79. On information and belief after reasonable investigation, the '929  
5 Accused Products include a server capable of detecting a time triggering event and,  
6 based on the time triggering event, sending to a mobile device advertisements and  
7 content information with a "meta tag" to identify one or more advertisements and  
8 advertisement display requirements.

9 80. As just one non-limiting example, set forth below (with claim language  
10 in italics) is a description of infringement of exemplary claims 9 and 10 of the '929  
11 Patent in connection with the Twitter advertising platform and associated backend  
12 servers and systems. This description is based on publicly available information.  
13 BlackBerry reserves the right to modify this description including, for example, on  
14 the basis of information about the '929 Accused Products that it obtains during  
15 discovery.

16 *9(a) A server, comprising:* – Defendant makes and/or uses Twitter Ads, the  
17 Twitter application, and the [www.twitter.com](http://www.twitter.com) website, and associated backend  
18 servers and systems. Regardless of whether the preamble of claim 9 adds any  
19 substantive limitation to the claim, the claim language is met by the '929 Accused  
20 Products, as the '929 Accused Products include a server comprising the elements  
21 further described below for the remaining claim limitations.









22 *9(b) a database organized into a plurality of memory location channels, each*  
23 *of the memory location channels storing information of a same category as a pre-*  
24 *defined category of each of the respective memory location channels,* – The Twitter  
25 application includes a news feed feature that allows users to watch video clips as  
26 well as to receive Tweet content from various sources, including advertisers. On  
27 information and belief, these features are enabled by a database on the Twitter  
28 server comprising a plurality of memory locations, each channel corresponding to a

1 pre-defined category of information that users may wish to access, such as other  
2 Twitter accounts that they follow.

3         The Twitter advertising platform includes tools such as Twitter Ads used by  
4 advertisers to send information over the Internet to a Twitter server that, on  
5 information and belief, stores the information to one of a plurality of memory  
6 location channels of the database based on pre-defined categories. On information  
7 and belief, the channels include one or more content categories of interest selected  
8 by Twitter users, categories developed by Defendant corresponding to interests of  
9 Twitter users and/or demographics such as the age, gender, or location of users. For  
10 example, Twitter Ads allows advertisers to create and save advertisements  
11 according to, among other things, one or more demographics (*e.g.*, age, gender,  
12 location), user interests (*e.g.*, Business, Events, Gaming), who users follow, and past  
13 behaviors (*e.g.*, donations). On information and belief, such advertising information  
14 is stored in the database based on the foregoing criteria.

15  
16  
17  
18  
19  
20  
21  
22  
23  
24  
25  
26  
27  
28

1  
2  
3  
4  
5  
6  
7  
8  
9  
10  
11  
12  
13  
14  
15  
16  
17  
18  
19  
20  
21  
22  
23  
24  
25  
26  
27  
28

 <b>Language targeting</b> Reach people who understand a particular language.	 <b>Gender targeting</b> Target your message to males or females.	 <b>Interest targeting</b> Serve up your campaign to users whose interests broadly align with your business.
 <b>Follower targeting</b> Target the followers of relevant accounts to reach people who are likely to be interested in your content.	 <b>Device targeting</b> Target users based on the specific mobile device they use to access Twitter.	 <b>Behavior targeting</b> Reach high-intent audiences on Twitter based on shopping and spending patterns.
 <b>Tailored Audiences targeting</b> Tailored Audiences uses your own CRM lists to reach specific groups of users on Twitter.	 <b>Keyword targeting</b> Act on signals of intent by delivering timely messages to users based on what they've recently Tweeted or engaged with in Tweets.	 <b>Geography targeting</b> Connect with a global audience or narrow the reach of your campaign to a specific country, region or even town.

(<https://business.twitter.com/en/targeting.html>; see also <https://business.twitter.com/en/help/campaign-setup/campaign-targeting/geo-gender-and-language-targeting.html> (“Geo, gender, language, and age targeting”); <https://business.twitter.com/en/targeting/follower.html> (“Target people based on who they follow”); <https://business.twitter.com/en/targeting/geo-and-language.html> (“Geography and language targeting”));

1  
2  
3  
4  
5  
6  
7  
8  
9  
10  
11  
12  
13  
14  
15  
16  
17  
18  
19  
20  
21  
22  
23  
24  
25  
26  
27  
28

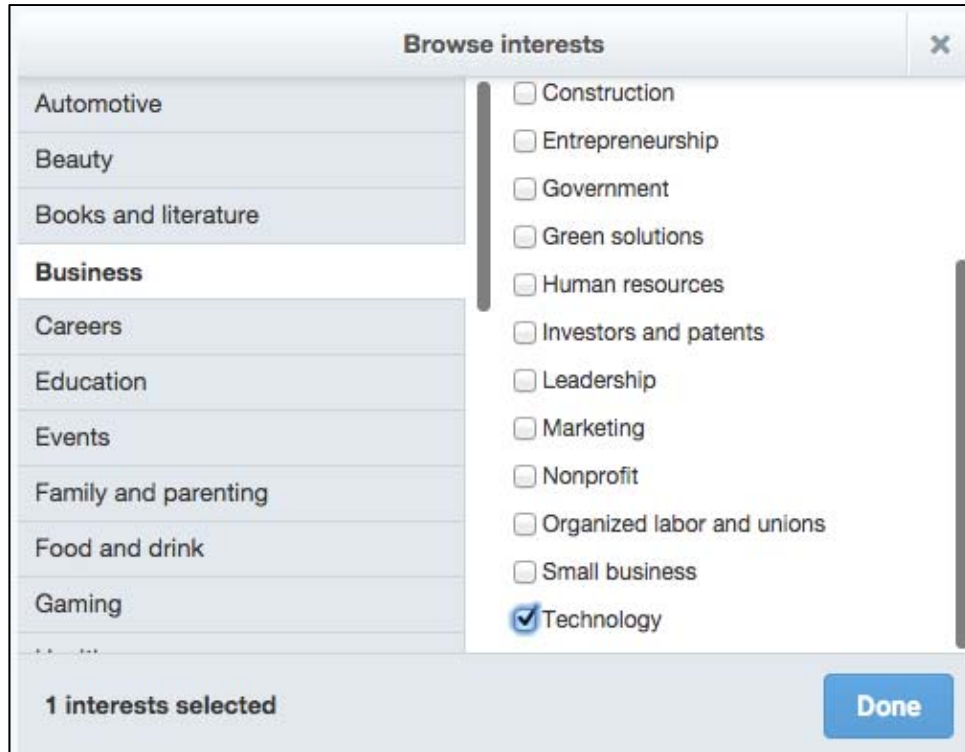

(<https://business.twitter.com/en/targeting/interest.html> (“Target based on broad interest categories”));

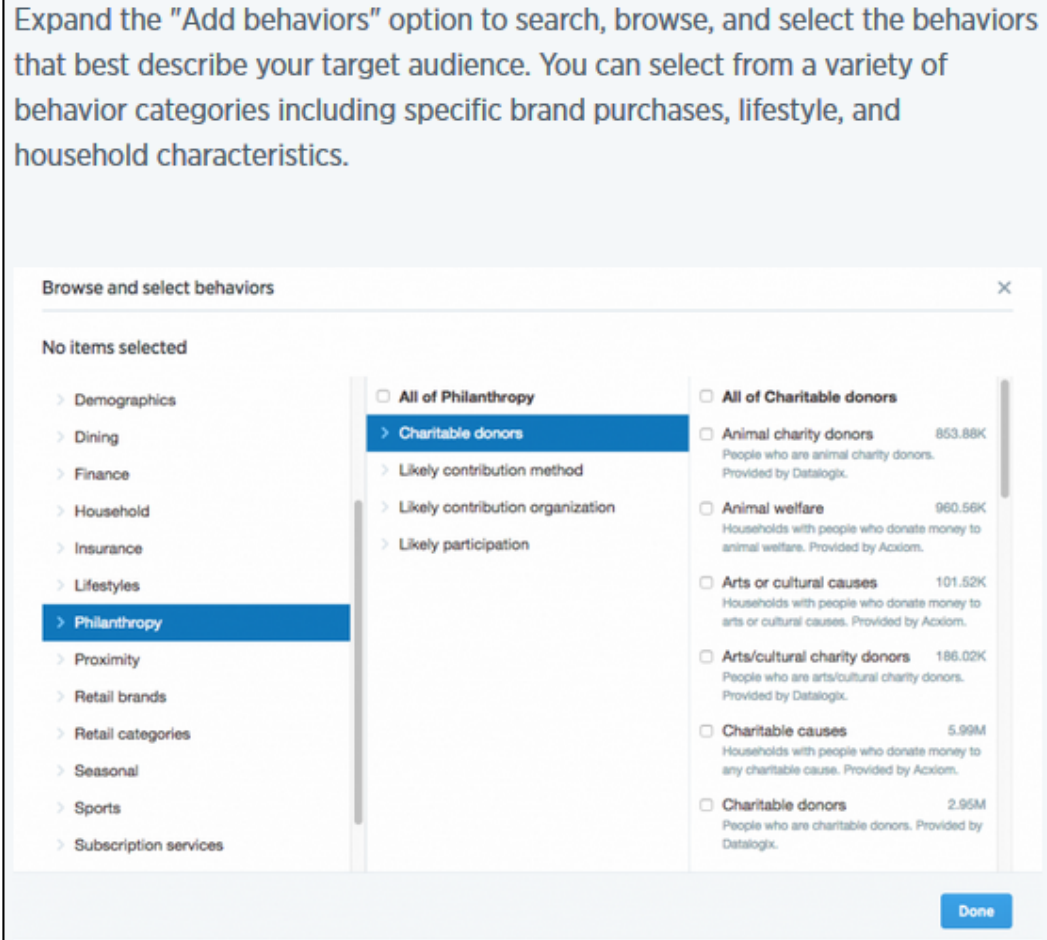

16 (<https://business.twitter.com/en/targeting/behavior.html> (“Behavior targeting  
 17 enables you to reach audiences on Twitter based on their shopping behavior,  
 18 lifestyle, and other key attributes.”)).

19 9(c) wherein upon detection of a triggering event comprising a time  
 20 triggering event, determining the information relevant to the detected triggering  
 21 event from among information stored in one of the plurality of memory location  
 22 channels of the database, – The Twitter application allows users to subscribe to or  
 23 “follow” other users and content streams and to receive notifications/live updates.  
 24 On information and belief, these notifications correspond to a “time triggering  
 25 event” in some cases—e.g., a predetermined release time for Tweet content, for  
 26 example (see, e.g., [https://business.twitter.com/en/help/campaign-editing-and-  
 27 optimization/scheduled-tweets.html](https://business.twitter.com/en/help/campaign-editing-and-optimization/scheduled-tweets.html)), a predetermined time for a particular event  
 28 (see, e.g., <https://business.twitter.com/en/help/campaign-setup/campaign-targeting/>



1 [event-targeting.html](#) (“Event targeting allows advertisers to quickly and easily  
2 discover, plan for, and activate events on Twitter. Our Event calendar, found in your  
3 ads account, surfaces hundreds of events around the world showing the people who  
4 are interested or participating. Our one-click campaign activation allows you to  
5 easily and directly reach that audience.”)), or a time period during which ad content  
6 is to be inserted into videos published by popular creators and publishers (*see*  
7 [https://media.twitter.com/en\\_us/articles/products/2018/in-stream-video-ads-for-](https://media.twitter.com/en_us/articles/products/2018/in-stream-video-ads-for-publishers.html)  
8 [publishers.html](#)). Accordingly, Twitter Ads allows advertisers to run advertisements  
9 based on a specified time schedule. On information and belief, the advertiser-  
10 specified times for publishing ads corresponds to a “time triggering event,” for  
11 example. On information and belief, upon detection of the time triggering event, the  
12 Twitter server determines the information relevant to the detected triggering event  
13 from among information stored in the plurality of memory location channels in the  
14 database.

## Scheduled Tweets

Twitter Ads allow you to schedule both organic and promoted-only Tweets to “go live” at a specific date and time. You can schedule Tweets within your ads account, up to a year in advance, and add them to new and existing campaigns. This feature is great for Tweets that need to be published on the weekend, evenings, or other busy times when you may not have time to tweet manually.

- 1 1. Once in your ads account, navigate to the "Creatives" <
- 2 "Tweets" tab.
- 3 2. Click the "New Tweet" button in the top right corner.
- 4 3. You'll be redirected to the Tweet Composer, where you
- 5 can create your Tweet. Add your Tweet copy, images,
- 6 videos, and cards from here.
- 7 4. Choose Promoted-only or not. Ticking the Promoted-
- 8 only box will only deliver your Tweet to users if they are
- 9 targeted in a Promoted Tweet campaign, not
- 10 organically to your followers. Untick this box in order to
- 11 schedule an organic Tweet. **Note:** only when logging in
- 12 as the @handle of the ads account will you be able to
- 13 unselect Promoted-only. *More on multi-user login.*
- 14 5. Once you add text, you can select the down arrow
- 15 button next to "Tweet".
- 16 6. Choose "Schedule" from that drop down menu.
- 17 7. Select the date and time you'd like your scheduled
- 18 tweet to go live.

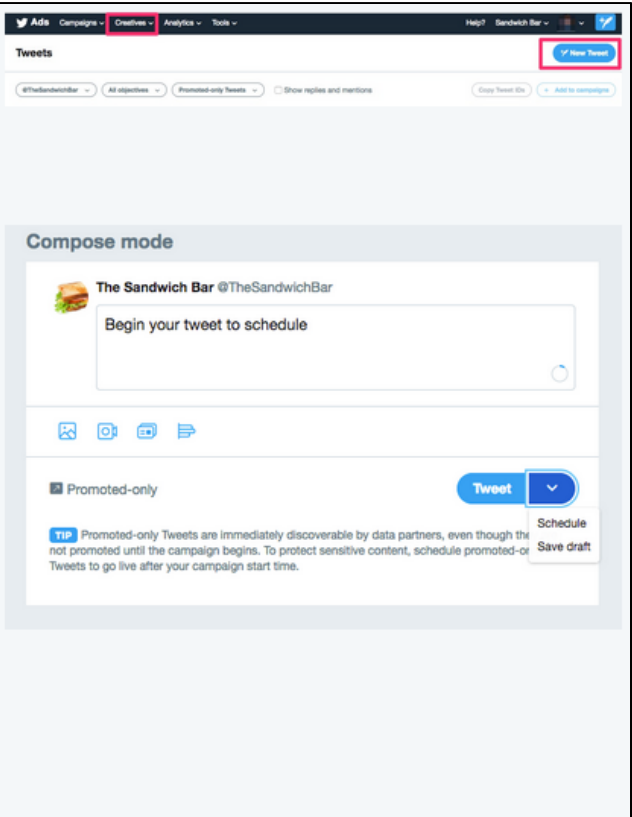

(<https://business.twitter.com/en/help/campaign-editing-and-optimization/scheduled-tweets.html>); see also:

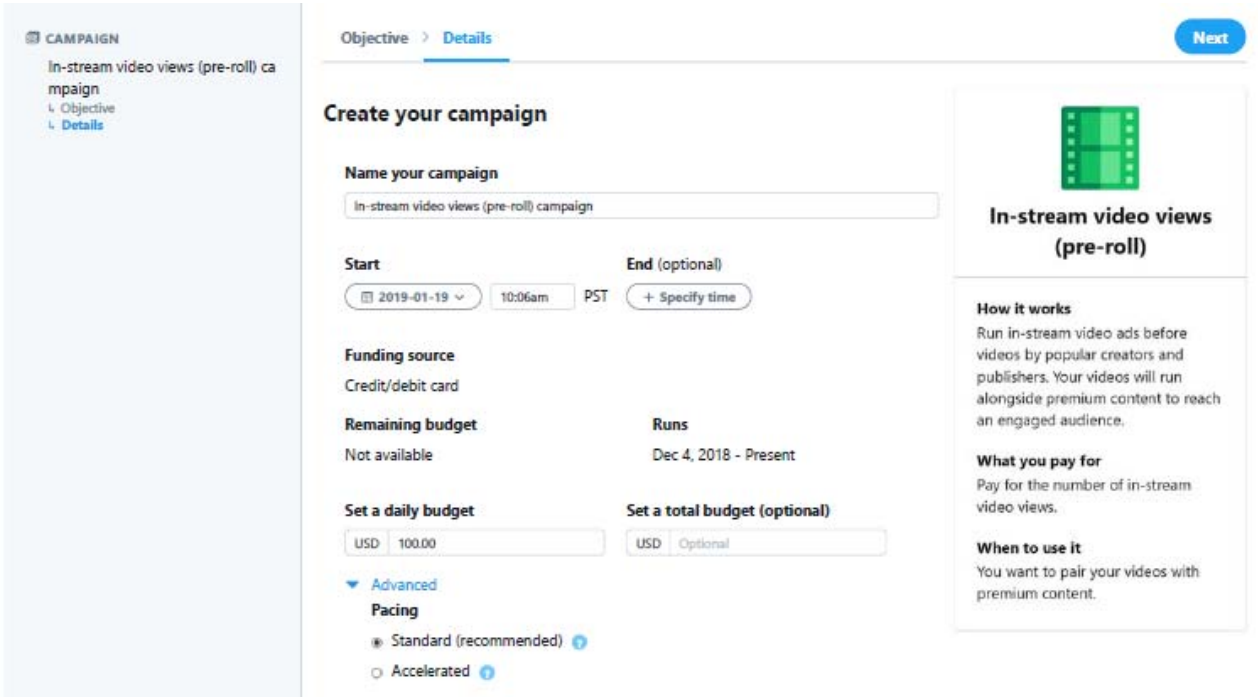

1 Ex. J (screenshot when logged into Twitter account from [https://ads.twitter.com/  
2 campaign/18ce54tgi4k/new/campaign/setup?objective=9](https://ads.twitter.com/campaign/18ce54tgi4k/new/campaign/setup?objective=9) as of June 4, 2019).

3 *9(d) when the information relevant to the detected triggering event comprises*  
4 *content information, inserting into the content information a meta tag for one or*  
5 *more advertisements to be displayed with the content information, and transmitting*  
6 *the content information that includes the meta tag to a mobile device, – On*  
7 information and belief, when the information relevant to the detected triggering  
8 event comprises content information, Twitter inserts into the content information a  
9 meta tag for one or more advertisements to be displayed with the content  
10 information, and transmits the content information that includes the meta tag to a  
11 mobile device. For example, Twitter’s in-stream video ads are inserted into content  
12 information sent to mobile devices by the Twitter server. (See  
13 [https://media.twitter.com/en\\_us/articles/products/2018/in-stream-video-ads-for-  
14 publishers.html](https://media.twitter.com/en_us/articles/products/2018/in-stream-video-ads-for-publishers.html).) Additionally, Twitter’s Promoted Tweets include content  
15 information as well as advertisements to be displayed with the content information.  
16 On information and belief, when content is delivered to a mobile device, the content  
17 includes “meta tags” or indications of where and when certain advertising  
18 information should be inserted.

19  
20  
21  
22  
23  
24  
25  
26  
27  
28

1  
2  
3  
4  
5  
6  
7  
8  
9  
10  
11  
12  
13  
14  
15  
16  
17  
18  
19  
20  
21  
22  
23  
24  
25  
26  
27  
28



<https://instapage.com/blog/what-are-promoted-tweets.>)

9(e) wherein the meta tag identifies the one or more advertisements and advertisement display requirements, and wherein the one or more advertisements are selected based on the detected triggering event. – On information and belief, the meta tags inserted into content information identify the advertisements and advertisement display requirements that should accompany the delivered content. For example, Twitter provides various templates for different styles for promoted Tweets, where each template includes display requirements. (See, e.g., <https://business.twitter.com/en/help/campaign-setup/advertiser-card-specifications.html>.) On information and belief, the selected advertisements are tailored according to several user characteristics, including the detected triggering event. Twitter advertisements can be designed to reach a specified audience. When created, these advertisements can be directed toward audiences of a particular demographic, in a particular geographic region, or with a particular interest. On information and belief, the desired audience parameters selected by the advertiser are used to select advertisements to be delivered to a particular mobile device (i.e.,

1 in determining which metatag to apply to a given set of content information). On  
2 information and belief, the time triggering event is among the information used by  
3 the server to select the appropriate advertisement.

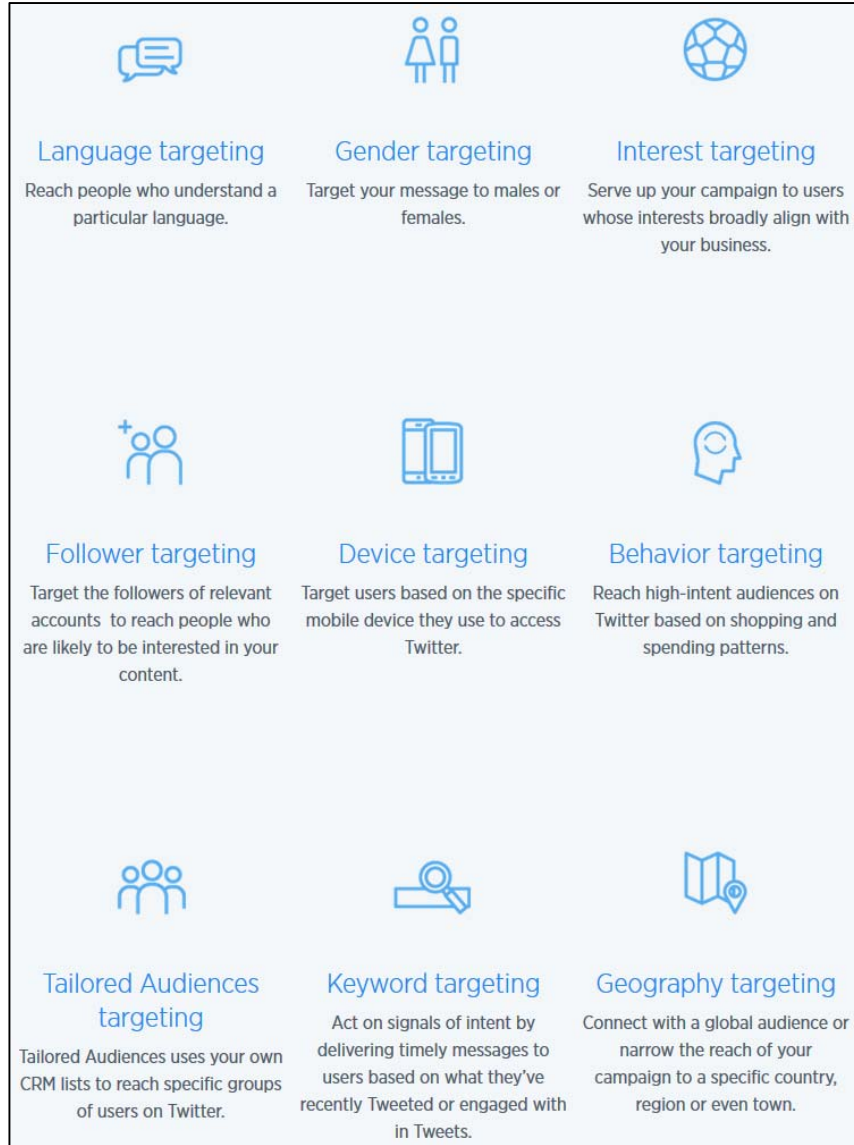

22 (<https://business.twitter.com/en/targeting.html>; see also [https://business.twitter.com/en/help/campaign-setup/campaign-targeting/geo-gender-and-language-](https://business.twitter.com/en/help/campaign-setup/campaign-targeting/geo-gender-and-language-targeting.html)  
23 [targeting.html](https://business.twitter.com/en/help/campaign-setup/campaign-targeting/geo-gender-and-language-targeting.html) (“Geo, gender, language, and age targeting”);  
24 <https://business.twitter.com/en/targeting/follower.html> (“Target people based on  
25 who they follow”); <https://business.twitter.com/en/targeting/geo-and-language.html>  
26 (“Geography and language targeting”));  
27  
28

1  
2  
3  
4  
5  
6  
7  
8  
9  
10  
11  
12  
13  
14  
15  
16  
17  
18  
19  
20  
21  
22  
23  
24  
25  
26  
27  
28

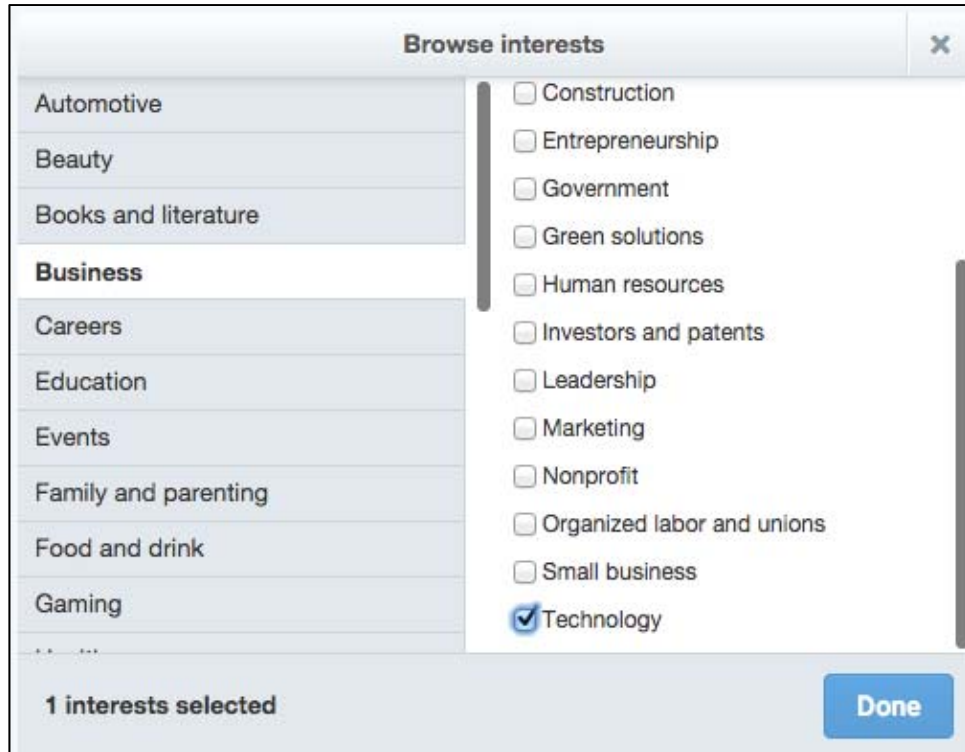

(<https://business.twitter.com/en/targeting/interest.html> (“Target based on broad interest categories”));

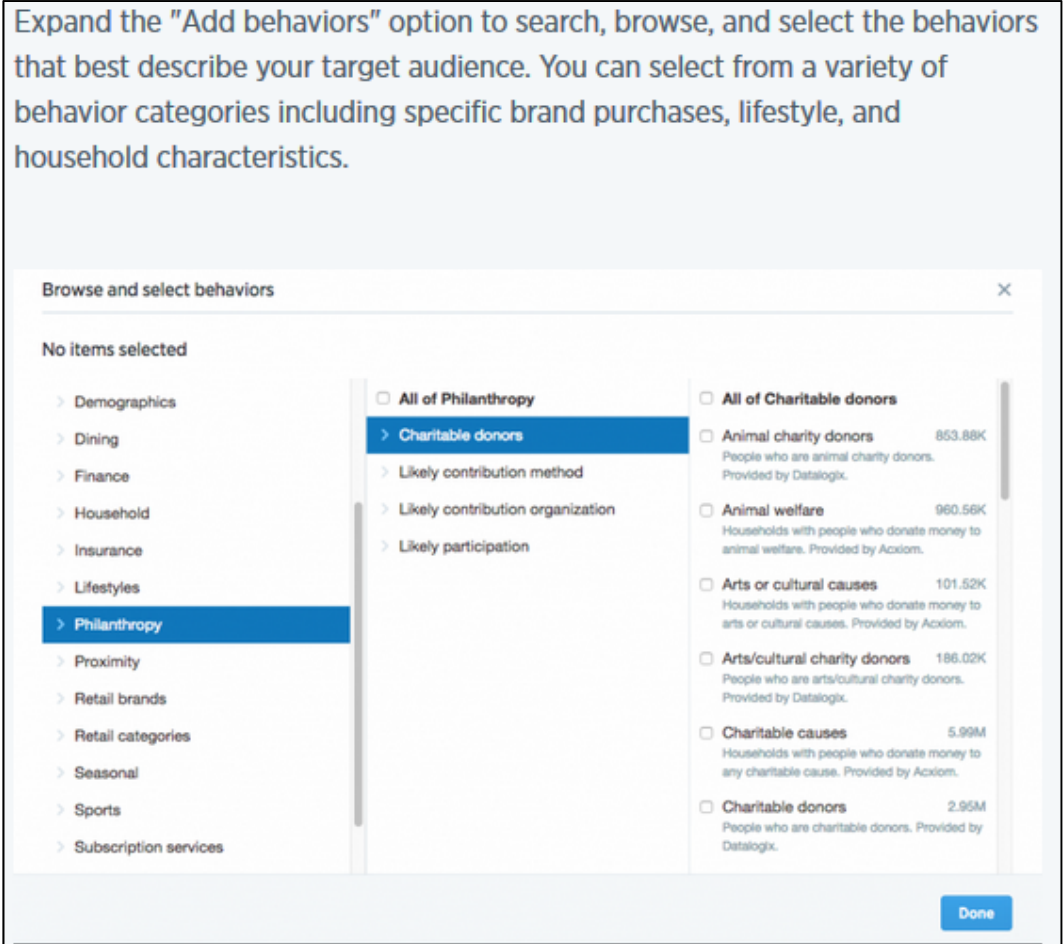

16 (<https://business.twitter.com/en/targeting/behavior.html> (“Behavior targeting  
 17 enables you to reach audiences on Twitter based on their shopping behavior,  
 18 lifestyle, and other key attributes.”));

19 **A low-friction way for publishers to monetize on  
 20 Twitter.**

21 Twitter is the fastest way to find out what’s happening in the world, and  
 22 video is the best way to show it. Today, publishers can post videos of up  
 23 to 10 minutes with each Tweet. Even better, you can monetize those  
 24 videos with In-Stream Video Ads.

25 Available to partners in the Amplify Publisher Program, In-Stream Video  
 26 Ads automatically pair pre-roll from advertisers with premium, brand-safe  
 27 video content on Twitter using the tags you’ve chosen for each video. It’s  
 28 an easy and effective way to drive additional revenue for publishers.

27 ([https://media.twitter.com/en\\_us/articles/products/2018/in-stream-video-ads-for-  
 28 publishers.html](https://media.twitter.com/en_us/articles/products/2018/in-stream-video-ads-for-publishers.html).);

# Scheduled Tweets

Twitter Ads allow you to schedule both organic and promoted-only Tweets to "go live" at a specific date and time. You can schedule Tweets within your ads account, up to a year in advance, and add them to new and existing campaigns. This feature is great for Tweets that need to be published on the weekend, evenings, or other busy times when you may not have time to tweet manually.

The screenshot shows the Twitter Ads interface. At the top, there are navigation tabs: 'Ads', 'Campaigns', 'Creatives', 'Analytics', and 'Tools'. The 'Creatives' tab is selected. Below the navigation, there's a 'Tweets' section with a 'New Tweet' button in the top right corner. The main content area shows the 'Compose mode' window for 'The Sandwich Bar @TheSandwichBar'. It includes a text input field with the placeholder 'Begin your tweet to schedule', icons for adding images, videos, and links, and a 'Promoted-only' checkbox. At the bottom of the compose window, there is a 'Tweet' button with a dropdown arrow, and options for 'Schedule' and 'Save draft'. A tip below the 'Promoted-only' checkbox states: 'Promoted-only Tweets are immediately discoverable by data partners, even though they are not promoted until the campaign begins. To protect sensitive content, schedule promoted-only Tweets to go live after your campaign start time.'

1. Once in your ads account, navigate to the "Creatives" < "Tweets" tab.
2. Click the "New Tweet" button in the top right corner.
3. You'll be redirected to the Tweet Composer, where you can create your Tweet. Add your Tweet copy, images, videos, and cards from here.
4. Choose Promoted-only or not. Ticking the Promoted-only box will only deliver your Tweet to users if they are targeted in a Promoted Tweet campaign, not organically to your followers. Untick this box in order to schedule an organic Tweet. **Note:** only when logging in as the @handle of the ads account will you be able to unselect Promoted-only. *More on multi-user login.*
5. Once you add text, you can select the down arrow button next to "Tweet".
6. Choose "Schedule" from that drop down menu.
7. Select the date and time you'd like your scheduled tweet to go live.

(<https://business.twitter.com/en/help/campaign-editing-and-optimization/scheduled-tweets.html>);



1  
2  
3  
4  
5  
6  
7  
8  
9  
10  
11  
12



13 (<https://instapage.com/blog/what-are-promoted-tweets>).

14 81. BlackBerry has been damaged by Defendant’s infringement of the ’929  
15 Patent and will continue to be damaged unless Defendant is enjoined by this Court.  
16 BlackBerry has suffered and continues to suffer irreparable injury for which there is  
17 no adequate remedy at law. The balance of hardships favors BlackBerry, and public  
18 interest is not disserved by an injunction.

19 82. BlackBerry is entitled to recover from Defendant all damages that  
20 BlackBerry has sustained as a result of Defendant’s infringement of the ’929 Patent,  
21 including without limitation lost profits and not less than a reasonable royalty.

22 **COUNT II: INFRINGEMENT OF U.S. PATENT NO. 8,296,351**

23 83. BlackBerry incorporates by reference and re-alleges all of the foregoing  
24 paragraphs of this First Amended Complaint as if fully set forth herein.

25 **The ’351 Patent**

26 84. The ’351 Patent discloses, among other things, a “system for pushing  
27 information to a mobile device” involving a “proxy content server,” which “is  
28 coupled to [an] information source and [a] wireless network.” ’351 Patent at

1 Abstract. The proxy content server “stores information received from the  
2 information source to one of a plurality of channels based on predefined information  
3 categories, and automatically transmits information from a selected channel over the  
4 wireless network to the mobile device.” *Id.*

5 85. The ’351 Patent teaches a proxy content server that provides targeted  
6 advertising information (*see, e.g., id.* at 4:28-46) and “aggregates existing  
7 information, such as Internet or Intranet content, from one or more Information  
8 sources, and pushes the information to a mobile device.” *Id.* at 2:59-62. This  
9 configuration “provides a method of combining the information so that the mobile  
10 device user has a consistent and transparent experience of receiving both  
11 information content and advertising content.” *Id.* at 2:63-66. The ’351 Patent  
12 inventors recognized that providing targeted advertisements and content was  
13 important “to achieve a revenue source for the provider of the information so the  
14 mobile device user gets a reduce[d] or free information service.” *Id.* at 3:16-19.

15 86. Fig. 1 of the ’351 Patent shows an exemplary network architecture  
16 according to an embodiment of the Patent for such a push notification system to  
17 improve the delivery of advertising content to mobile users. Figure 1 illustrates “a  
18 plurality of Information Sources 10, a Proxy Content Server 18, a Proxy Content  
19 Server Database 19, and a plurality of mobile devices 24.” *Id.* at 2:21-23.

20  
21  
22  
23  
24  
25  
26  
27  
28

1  
2  
3  
4  
5  
6  
7  
8  
9  
10  
11  
12  
13  
14  
15  
16  
17  
18  
19  
20  
21  
22  
23  
24  
25  
26  
27  
28

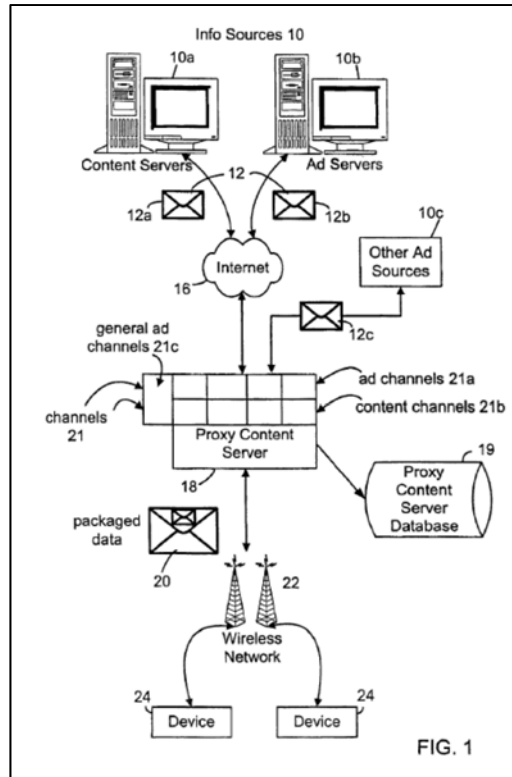

87. The '351 Patent thus claims, among other things, “[a] system for pushing information to a mobile device, comprising: a proxy content server that receives information over a computer network from an information source and stores the information to one of a plurality of channels based on pre-defined information categories, wherein the plurality of channels comprise memory locations included in at least one of the proxy content server or a proxy content server database; the proxy content server to receive a feedback signal over a wireless network that indicates a position of the mobile device, and to use the feedback signal to select a channel for transmission of the information from the selected channel over the wireless network to the mobile device, wherein the information comprises at least one of static advertising information, dynamic advertising information, default advertising information, or content information, and wherein a combination of the static advertising information with one of the dynamic or default advertising information comprises an advertisement or an information bulletin.” *Id.* at Claim 1.

1                                    **The Inventions Claimed in the '351 Patent Were Not**  
2                                    **Well-Understood, Routine, or Conventional**

3            88. The use of a proxy content server to receive information over a  
4 computer network from an information source and store the information to one of a  
5 plurality of channels based on pre-defined information categories, wherein the  
6 plurality of channels comprise memory locations included in at least one of the  
7 proxy content server or a proxy content server database, and to receive a feedback  
8 signal over a wireless network that indicates the position of the mobile device and to  
9 use the feedback signal to select a channel for transmission of the information from  
10 the selected channel over the wireless network to the mobile device, wherein the  
11 information comprises at least one of static advertising information, dynamic  
12 advertising information, default advertising information, or content information, and  
13 wherein a combination of the static advertising information with one of the dynamic  
14 or default advertising information comprises an advertisement or an information  
15 bulletin, was not common or conventional at the time of the '351 Patent.

16            89. The inventors of the '351 Patent recognized the need to transmit  
17 targeted advertising, facilitated by a proxy content server, in order to deliver  
18 relevant and timely advertising information to mobile users. As taught by the '351  
19 Patent, the "Proxy Content Server [] provides a method of combining the  
20 information so that the mobile device user has a consistent and transparent  
21 experience of receiving both information content and advertising content." *Id.* at  
22 2:63-66.

23            90. Given the state of the art at the time of the invention of the '351 Patent,  
24 the inventive concepts of the '351 Patent were not conventional, well-understood, or  
25 routine. The '351 Patent discloses, among other things, an unconventional and  
26 technological solution to an issue arising specifically in the context of wireless  
27 communication devices, and the delivery of advertising content to such devices.  
28 The solution implemented by the '351 Patent provides a specific and substantial

1 improvement over prior wireless communication systems used for this purpose,  
2 resulting in an improved system for the delivery of relevant and timely advertising  
3 information to mobile device users. The '351 Patent achieves this result by  
4 introducing novel elements directed to improving the function and working of  
5 wireless communication systems such as, among other things, the claimed "proxy  
6 content server" (all claims), positioned in a wireless network and configured  
7 according to the claims, the capability of the proxy content server to "receive a  
8 feedback signal over a wireless network that indicates a position of the mobile  
9 device, and to use the feedback signal to select a channel for transmission of the  
10 information from the selected channel over the wireless network to the mobile  
11 device," (claims 1-13) and the capability to combine "static advertising information  
12 with one of [] dynamic or default advertising information" to result in "an  
13 advertisement or an information bulletin" (all claims).

14 91. Consistent with the problem addressed being rooted in wireless  
15 communication to mobile devices, the '351 Patent's solutions are also rooted in the  
16 same technology that cannot be performed with pen and paper or in the human  
17 mind.

18 92. This technical context is reflected in the '351 Patent's claims. For  
19 example, the claims recite a "proxy content server that receives information over  
20 computer network from an information source" and which transmits information  
21 over a "wireless network" to "mobile devices."

22 93. A person having ordinary skill in the art at the time of the inventions of  
23 the '351 Patent would not have understood that the inventions could or would be  
24 performed solely in the human mind or using pen and paper. Using pen and paper  
25 would ignore the stated purpose of the '351 Patent and the problem it was  
26 specifically designed to address, which arose in the context of needing an improved  
27 system for delivering content, including advertising content, from an information  
28 source to mobile users over a wireless network. Doing so would also run counter to

1 the inventors' detailed description of the inventions and the language of the claims  
2 and be a practical impossibility.

### 3 **'351 Patent Allegations**

4 94. Defendant has infringed and is infringing, either literally or under the  
5 doctrine of equivalents, the '351 Patent in violation of 35 U.S.C. § 271 *et seq.*,  
6 directly, by making, using, selling, offering for sale, and/or importing into the  
7 United States without authority or license, the Twitter advertising platform  
8 including Twitter Ads, which transmits targeted advertisements to Twitter users, as  
9 well as associated backend servers and systems (hereinafter "the '351 Accused  
10 Products") that infringe at least claims 1 and 14 of the '351 Patent. The '351  
11 Accused Products are a non-limiting example that was identified based on publicly  
12 available information, and BlackBerry reserves the right to identify additional  
13 infringing activities, products and services, including, for example, on the basis of  
14 information obtained during discovery.

15 95. On information and belief after reasonable investigation, the '351  
16 Accused Products include a proxy content server that receives information from an  
17 information source, stores the information in one of a plurality of channels, receives  
18 a feedback signal over a wireless network that indicates a position of a mobile  
19 device, uses the feedback signal to select a channel for transmission of the  
20 information over the wireless network to the mobile device, wherein the information  
21 comprises at least one of static advertising information, dynamic advertising  
22 information, default advertising information, or content information, and wherein a  
23 combination of the static advertising information with one of the dynamic or default  
24 advertising information comprises an advertisement or an information bulletin.

25 96. As just one non-limiting example, set forth below (with claim language  
26 in italics) is a description of infringement of exemplary claim 1 of the '351 Patent in  
27 connection with the Twitter advertising platform and associated backend servers and  
28 systems. This description is based on publicly available information. BlackBerry

1 reserves the right to modify this description, including, for example, on the basis of  
2 information about the '351 Accused Products that it obtains during discovery.

3 *I(a) A system for pushing information to a mobile device, comprising: –*  
4 Defendant makes and/or uses Twitter Ads, the Twitter application, and the  
5 [www.twitter.com](http://www.twitter.com) website, and associated backend servers and systems. Regardless  
6 of whether the preamble of claim 1 adds any substantive limitation to the claim, the  
7 claim language is met by the '351 Accused Products, as the '351 Accused Products  
8 comprise a system for pushing information to mobile devices, including the mobile  
9 devices of Twitter users.

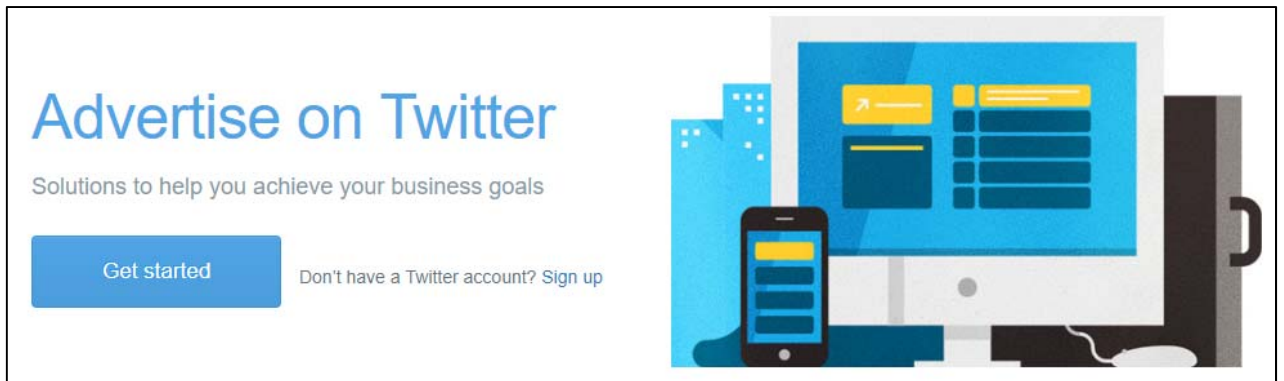

10  
11  
12  
13  
14  
15  
16  
17  
18  
19  
20  
21  
22  
23  
24  
25  
26  
27  
28

1

2

3

4

5

6

7

8

9

10

11

12

13

14

15

**How it works**

 **Choose your target audience**

Reach the right audience by targeting based on interests, geography, gender, device, or users similar to your followers. In addition, maximize the relevancy of your message by targeting by keywords in people's Tweets.

 **Amplify your message and get discovered**

Get your Tweets and your account in front of more people who are interested in you.

 **Set a budget and pay for what works**

Only pay when users follow your account or retweet, like, reply, or click on your Promoted Tweet. You're in complete control. There's no minimum spend, and you can start and stop at any time.

16 <https://ads.twitter.com/login>).

17 *I(b) a proxy content server that receives information over a computer*  
18 *network from an information source and stores the information to one of a plurality*  
19 *of channels based on pre-defined information categories, wherein the plurality of*  
20 *channels comprise memory locations included in at least one of the proxy content*  
21 *server or a proxy content server database; – On information and belief, Defendant’s*  
22 *advertising platform includes tools such as Twitter Ads and Ads Manager used by*  
23 *information sources such as advertisers or a Twitter advertisement intake server to*  
24 *send information over the Internet or Intranet to a Twitter proxy content server that*  
25 *stores the information to one of a plurality of channels based on pre-defined*  
26 *information categories.*

27  
28



# Twitter Ads Manager









We want every advertiser to get the best performance from their campaigns. Twitter Ads Manager provides a central workspace to plan, manage, and report on campaigns.

You can see Ads Manager by logging into your ads account ([ads.twitter.com](https://ads.twitter.com)), where you will automatically be brought to the Ads Manager as your home screen. From there, you can customize your view to see relevant campaigns, creatives, and results.

(<https://business.twitter.com/en/help/campaign-setup/twitter-ads-manager.html>).

On information and belief, the plurality of channels based on pre-defined information categories include one or more content categories of interest selected by Twitter users, categories developed by Defendant corresponding to interests of Twitter users and/or demographics such as the age, gender, or location of users. On information and belief, the plurality of channels comprise memory locations included in at least one of the proxy content server or a proxy content server database. For example, Twitter Ads allows advertisers to create and save advertisements according to, among other things, one or more demographics (*e.g.*, age, gender, location), user interests (*e.g.*, Business, Events, Gaming), who users follow, and past behaviors (*e.g.*, donations). On information and belief, such advertising information is stored at the Twitter proxy content server or proxy content server database based on the foregoing criteria.

1  
2  
3  
4  
5  
6  
7  
8  
9  
10  
11  
12  
13  
14  
15  
16  
17  
18  
19  
20  
21  
22  
23  
24  
25  
26  
27  
28

 <p><b>Language targeting</b> Reach people who understand a particular language.</p>	 <p><b>Gender targeting</b> Target your message to males or females.</p>	 <p><b>Interest targeting</b> Serve up your campaign to users whose interests broadly align with your business.</p>
 <p><b>Follower targeting</b> Target the followers of relevant accounts to reach people who are likely to be interested in your content.</p>	 <p><b>Device targeting</b> Target users based on the specific mobile device they use to access Twitter.</p>	 <p><b>Behavior targeting</b> Reach high-intent audiences on Twitter based on shopping and spending patterns.</p>
 <p><b>Tailored Audiences targeting</b> Tailored Audiences uses your own CRM lists to reach specific groups of users on Twitter.</p>	 <p><b>Keyword targeting</b> Act on signals of intent by delivering timely messages to users based on what they've recently Tweeted or engaged with in Tweets.</p>	 <p><b>Geography targeting</b> Connect with a global audience or narrow the reach of your campaign to a specific country, region or even town.</p>

(<https://business.twitter.com/en/targeting.html>; see also <https://business.twitter.com/en/help/campaign-setup/campaign-targeting/geo-gender-and-language-targeting.html> (“Geo, gender, language, and age targeting”); <https://business.twitter.com/en/targeting/follower.html> (“Target people based on who they follow”); <https://business.twitter.com/en/targeting/geo-and-language.html> (“Geography and language targeting”));

1  
2  
3  
4  
5  
6  
7  
8  
9  
10  
11  
12  
13  
14  
15  
16  
17  
18  
19  
20  
21  
22  
23  
24  
25  
26  
27  
28

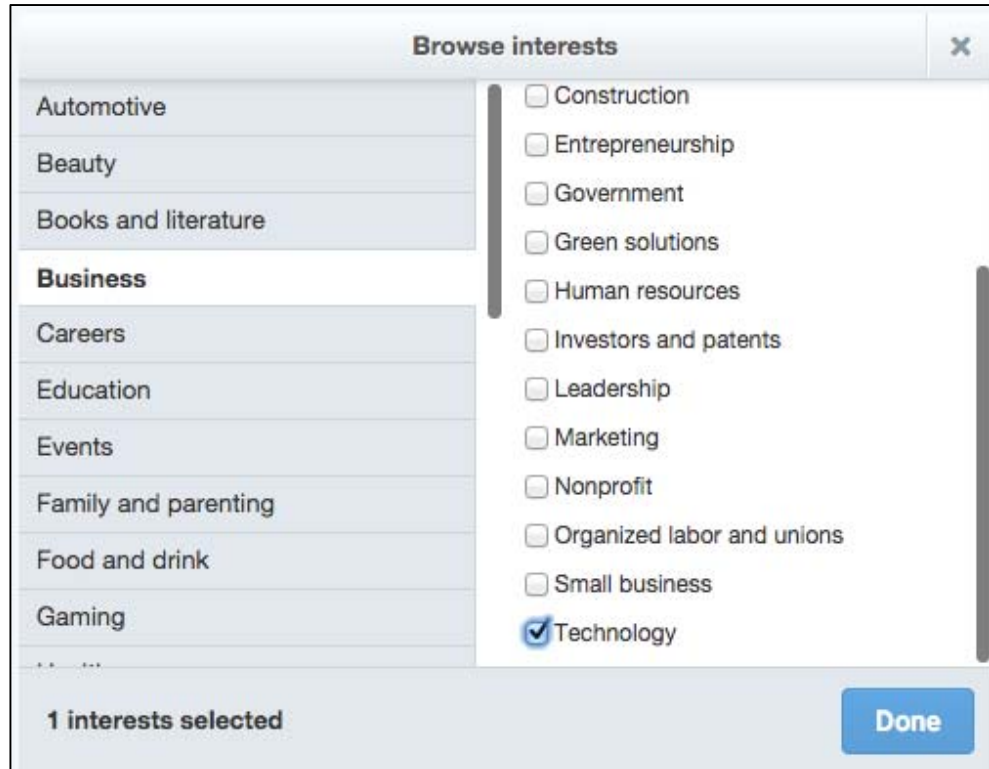

(<https://business.twitter.com/en/targeting/interest.html> (“Target based on broad interest categories”));

1 Expand the "Add behaviors" option to search, browse, and select the behaviors  
 2 that best describe your target audience. You can select from a variety of  
 3 behavior categories including specific brand purchases, lifestyle, and  
 4 household characteristics.

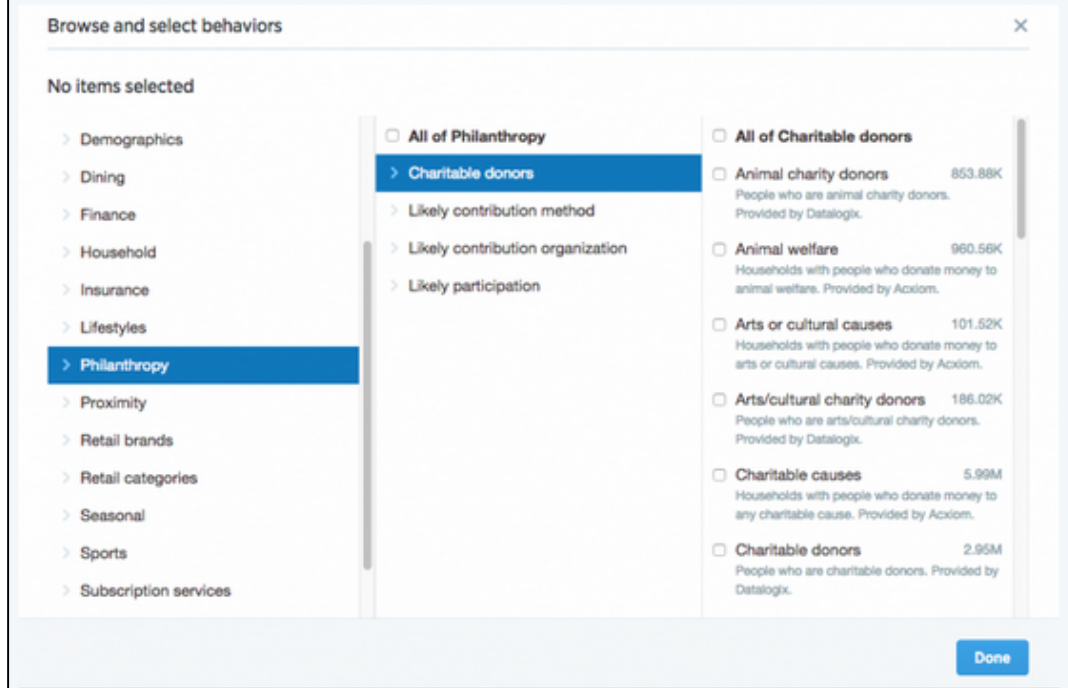

16 (<https://business.twitter.com/en/targeting/behavior.html> (“Behavior targeting  
 17 enables you to reach audiences on Twitter based on their shopping behavior,  
 18 lifestyle, and other key attributes.”)).

19 *I(c) the proxy content server to receive a feedback signal over a wireless*  
 20 *network that indicates a position of the mobile device, and to use the feedback*  
 21 *signal to select a channel for transmission of the information from the selected*  
 22 *channel over the wireless network to the mobile device, – Advertisements through*  
 23 *the Twitter advertising platform can be designed to reach a specified audience.*  
 24 *When created, these advertisements can be directed towards audiences of a*  
 25 *particular demographic, audiences in a particular geographic region, and audiences*  
 26 *with a particular interest, among others. For example, the Twitter advertising*  
 27 *platform sends targeted advertisements based on user location such that, on*  
 28 *information and belief, the Twitter proxy content server sends advertising*

1 information to users based on location of the user as indicated by a feedback signal  
 2 sent from the user’s device over a wireless network to the Twitter proxy content  
 3 server. On information and belief, the Twitter proxy content server selects the  
 4 channel for transmission of information to the mobile device using the feedback  
 5 signal as well as additional criteria, including the user demographics, and/or the  
 6 user’s behavior, for example.

Twitter’s geo targeting is based on a user’s recent location. This is a combination of a user’s current location as well as their recent location history. Twitter uses several signals for determining whether a user is presently in a particular geographic location, such as a user’s web IP address, mobile GPS signal, mobile wi-fi signal, and real-time signals, such as when a user includes their location in a Tweet. We use all of these signals to create sophisticated machine-learned models that predict a user’s location. More on Twitter’s [data collection for ads](#).

(<https://business.twitter.com/en/help/campaign-setup/campaign-targeting/geo-gender-and-language-targeting.html>).

Additionally, on information and belief, the Twitter application enables location tracking of a user’s mobile device by default.

1  
2  
3  
4  
5  
6  
7  
8  
9  
10  
11  
12  
13  
14  
15  
16  
17  
18  
19  
20  
21  
22  
23  
24  
25  
26  
27  
28

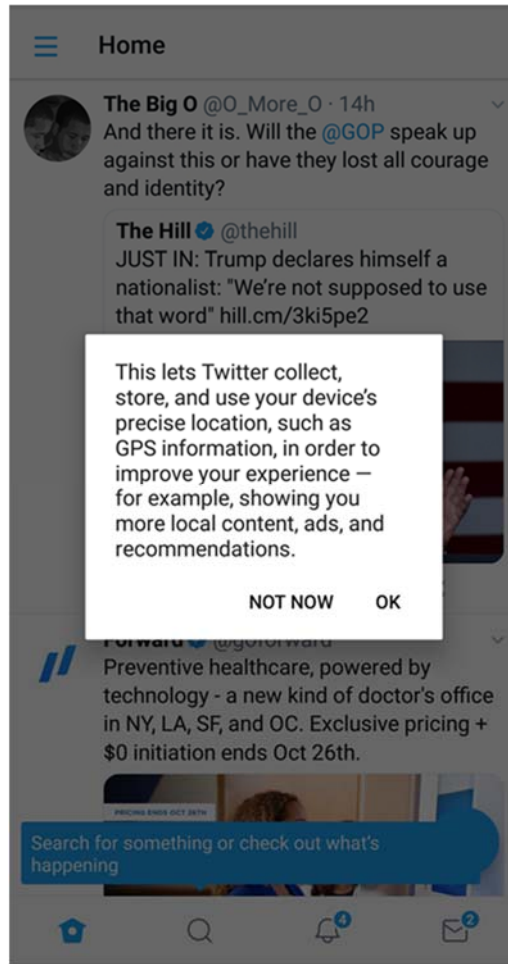

; see also:

## How to use precise location on mobile devices

**Enabling precise location through Twitter's official apps allows Twitter to collect, store, and use your precise location, such as GPS information. This allows us to provide, develop, and improve a variety of our services, including but not limited to:**

- Delivery of content, including Tweets and advertising, that is better tailored to your location.
- Delivery of location-specific trends.
- Showing your followers the **location you are Tweeting** from as part of your Tweet, if you decide to geotag your Tweet.

1 ([https://help.twitter.com/en/safety-and-security/twitter-location-services-for-](https://help.twitter.com/en/safety-and-security/twitter-location-services-for-mobile)  
2 [mobile](https://help.twitter.com/en/safety-and-security/twitter-location-services-for-mobile)).

3 *I(d) wherein the information comprises at least one of static advertising*  
4 *information, dynamic advertising information, default advertising information, or*  
5 *content information, and wherein a combination of the static advertising*  
6 *information with one of the dynamic or default advertising information comprises*  
7 *an advertisement or an information bulletin. – On information and belief,*  
8 *advertisements seen on at least Twitter include static advertising information that*  
9 *relates to an identity of the advertiser, such as the name and logo of the advertiser,*  
10 *and that is combined with dynamic and default advertising information that relates*  
11 *to a specific advertisement that is or is not time-sensitive, such as an advertisement*  
12 *image, description, “call to action” item and associated link(s).*



1  
2  
3  
4  
5  
6  
7  
8  
9  
10  
11  
12  
13  
14  
15  
16  
17  
18  
19  
20  
21  
22  
23  
24  
25  
26  
27  
28



(<https://instapage.com/blog/what-are-promoted-tweets>).

97. BlackBerry has been damaged by Defendant’s infringement of the ’351 Patent and will continue to be damaged unless Defendant is enjoined by this Court. BlackBerry has suffered and continues to suffer irreparable injury for which there is no adequate remedy at law. The balance of hardships favors BlackBerry, and public interest is not disserved by an injunction.

98. BlackBerry is entitled to recover from Defendant all damages that BlackBerry has sustained as a result of Defendant’s infringement of the ’351 Patent, including without limitation lost profits and not less than a reasonable royalty.

**COUNT III: INFRINGEMENT OF U.S. PATENT NO. 9,349,120**

99. BlackBerry incorporates by reference and re-alleges all of the foregoing paragraphs of this First Amended Complaint as if fully set forth herein.

**The ’120 Patent**

100. The ’120 Patent discloses, among other things, “[m]ethods, systems, and computer programming products . . . for silencing message threads” whereby “[o]nce a message thread has been silenced, the user will no longer receive notifications of new messages added to the thread.” ’120 Patent, Abstract.



1           101. The '120 Patent explains that “[e]lectronic messages, such as electronic  
2 mail messages and messages posted to group sites, can be grouped into message  
3 threads. Each message thread can relate to a particular matter such as a particular  
4 topic of conversation or an activity. For example, a user may be part of an email  
5 group which is involved in an ongoing discussion. Each email in the discussion  
6 could be included in the same message thread. A user may receive a notification  
7 each time an electronic message is received. Notifications could include, for  
8 example, auditory user alerts such as ring tones, visual alerts such as flashing lights  
9 or pop-ups and physical alerts such as vibrations.” *Id.* at 1:22-32.

10           102. The '120 Patent provides a user with the capability to silence such  
11 notifications on a per-thread basis, thereby overriding a currently enabled  
12 notification setting and allowing notifications to be received for other non-silenced  
13 threads. *Id.* at 2:22-49. Figures 5 and 6 of the '120 Patent detail an exemplary  
14 method by which such notification silencing for a method thread occurs. As shown  
15 in Fig. 5, “[a] method 500 can begin at 502 where a user can, using suitably-  
16 configured GUI(s) and input device, select a message inbox. [An] inbox generally  
17 refers to a virtual folder with which incoming messages are initially associated. . . .  
18 At 504, the user selects a message thread using, for example, a user interface such as  
19 a GUI 304, displaying one or more selectable options such as a list of one or more  
20 message threads. A message thread may be selected by the user by, for example,  
21 selecting a displayed, selectable option associated with the message thread using  
22 point-and-click functionality as described above. At 506, a user can silence a  
23 message thread or reactivate a message thread that had previously been silenced  
24 with respect to a device the user is using.” *Id.* at 11:11-13:1.

1  
2  
3  
4  
5  
6  
7  
8  
9  
10  
11  
12  
13  
14  
15  
16  
17  
18  
19  
20  
21  
22  
23  
24  
25  
26  
27  
28

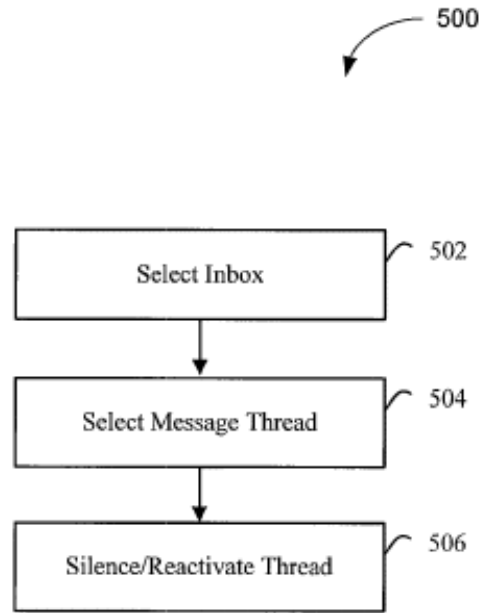

**FIG. 5**

*Id.* at Fig. 5.

103. Fig. 6 shows an exemplary method of handling an incoming electronic message depending on whether or not the message thread with which the message is associated has been silenced. “A method 600 can begin at 602 where a message is received which is addressed or otherwise identified in such a way as to be associated with an inbox. . . . At 604, it may be determined whether or not the message relates to a new matter, such as a new topic of conversation or a new activity. . . . If the message does relate to a new matter, at 606, a new message thread is started. At 608, the user is notified of the message according to any currently-enabled notification settings, as described above. If the message does not relate to a new matter, at 610, a thread to which the message belongs may be determined. . . . At 612, it is may determined whether or not the message thread to which the message belongs has been silenced by the user. For example, a data record in memory 300 which is associated with the message thread may be checked to determine whether a flag has been set indicating that the thread has been silenced. If the message thread has been

1 silenced by the user then no notification may be activated. . . . If the message thread  
 2 has not been silenced by the user, then at 616 the user may be notified of the  
 3 incoming message according to any currently-enabled notification settings.” *Id.* at  
 4 14:5-55.

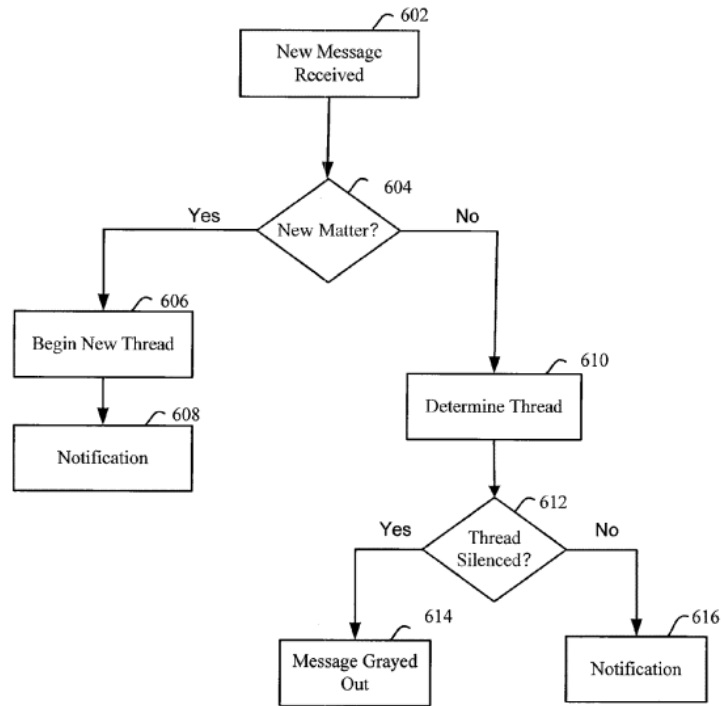

FIG. 6

18 *Id.* at Fig. 6.

19 104. The '120 Patent claims, among other things, “[a] method for silencing  
 20 notifications for incoming electronic messages to a communication system, the  
 21 communication system comprising a data processor, media readable by the data  
 22 processor and a communications subsystem, the communications subsystem adapted  
 23 to receive the incoming electronic messages, the method comprising: receiving one  
 24 or more selected message threads for silencing; in response to receiving the one or  
 25 more selected message threads, activating one or more flags, each flag in association  
 26 with a selected message thread of the one or more selected message threads, wherein  
 27 the one or more flags indicate that the associated one or more selected message  
 28 threads have been silenced; receiving a new incoming electronic message;

1 identifying the new incoming message as associated with the selected one or more  
2 message threads; determining that a message thread associated with the new  
3 incoming message has been flagged as silenced using the one or more flags;  
4 overriding at least one currently-enabled notification setting to prevent a notification  
5 pertaining to receipt of the new incoming message from being activated; and  
6 displaying the new incoming electronic message in an inbox together with any  
7 message thread not flagged as silenced, while silencing any further notifications  
8 pertaining to receipt of the new incoming electronic message; wherein the new  
9 incoming message thread flagged as silenced is displayed in the inbox in a different  
10 manner than any message thread not flagged as silenced.” *Id.* at claim 13.

11 **The Inventions Claimed in the ’120 Patent Were Not**  
12 **Well-Understood, Routine, or Conventional**

13 105. A communication system enabling a flag associated with an electronic  
14 message thread to be activated in order to silence notifications for the message  
15 thread and thereby override a currently-enabled notification setting was not common  
16 or conventional at the time of the ’120 Patent.

17 106. The inventor of the ’120 Patent recognized the need in electronic  
18 communications systems to silence notifications for specific message threads while  
19 still allowing new incoming messages in the silenced threads to be displayed in an  
20 inbox together with any message thread not flagged as silenced. ’120 Patent,  
21 Abstract. The inventor further identified the benefit of solving this described  
22 problem by providing a communication system enabling “receiving a new incoming  
23 electronic message; identifying the new incoming message as associated with one or  
24 more message threads; determining that a message thread associated with the new  
25 incoming message has been flagged as silenced; and overriding at least one  
26 currently-enabled notification setting to prevent a notification pertaining to receipt  
27 of the new incoming message from being activated.” *Id.* at 2:42-49. Thus,  
28

1 notifications for messages associated with a specific messaging thread may be  
2 silenced while still allowing for notifications from non-silenced message threads.

3 107. Given the state of the art at the time of the invention of the '120 Patent,  
4 the inventive concepts of the '120 Patent were not conventional, well-understood, or  
5 routine. The '120 Patent discloses, among other things, an unconventional and  
6 technological solution to an issue arising specifically in the context of electronic  
7 communications systems and electronic messaging received within those  
8 communications systems. The solution implemented by the '120 Patent provides a  
9 specific and substantial improvement over prior messaging notification systems,  
10 resulting in an improved electronic communications system, including by  
11 introducing novel elements directed to improving the function and working of  
12 communications systems such as, among other things, the claimed “activating one  
13 or more flags, each flag in association with a selected message thread of the one or  
14 more selected message threads, wherein the one or more flags indicate that the  
15 associated one or more selected message threads have been silenced” (claims 13 and  
16 24; substantially similar limitation in claim 1), “determining that a message thread  
17 associated with the new incoming message has been flagged as silenced using the  
18 one or more flags” (claims 13 and 24; substantially similar limitation in claim 1),  
19 and “displaying the new incoming electronic message in an inbox together with any  
20 message thread not flagged as silenced, while silencing any further notifications  
21 pertaining to receipt of the new incoming electronic message; wherein the new  
22 incoming message thread flagged as silenced is displayed in the inbox in a different  
23 manner than any message thread not flagged as silenced” (claims 13 and 24;  
24 substantially similar limitation in claim 1).

25 108. Consistent with the problem addressed being rooted in electronic  
26 messaging between wireless communications devices, the '120 Patent's solutions  
27 naturally are also rooted in the same technology that cannot be performed with pen  
28 and paper or in the human mind.

1 109. This technical context is reflected in the '120 Patent's claims. For  
2 example, various claims of the '120 Patent require one or more electronic messages  
3 associated with one or more message threads, selected message thread(s) for  
4 silencing, settings for notifications pertaining to receipt of new incoming electronic  
5 messages associated with one or more such threads, and displaying such messages  
6 in an inbox.

7 110. A person having ordinary skill in the art at the time of the inventions of  
8 the '120 Patent would not have understood that the inventions could or would be  
9 performed solely in the human mind or using pen and paper. Using pen and paper  
10 would ignore the stated purpose of the '120 Patent and the problem it was  
11 specifically designed to address. Doing so would also run counter to the inventors'  
12 detailed description of the inventions and the language of the claims and be a  
13 practical impossibility.

14 **'120 Patent Allegations**

15 111. Defendant has infringed and is infringing, either literally or under the  
16 doctrine of equivalents, the '120 Patent in violation of 35 U.S.C. § 271 *et seq.*,  
17 directly and/or indirectly, by making, using, selling, offering for sale, and/or  
18 importing into the United States without authority or license, the Twitter application  
19 (hereinafter "the '120 Accused Products") that infringes at least claims 1, 13, and 24  
20 of the '120 Patent.

21 112. On information and belief after reasonable investigation, the '120  
22 Accused Products contain messaging functionality designed and used to silence  
23 notifications for selected conversation threads thereby overriding a currently-  
24 enabled notification setting in an infringing manner.

25 113. As just one non-limiting example, set forth below (with claim language  
26 in italics) is a description of infringement of exemplary claim 24 of the '120 Patent  
27 in connection with the Twitter application. This description is based on publicly  
28 available information. BlackBerry reserves the right to modify this description,

1 including, for example, on the basis of information about the '120 Accused Products  
2 that it obtains during discovery.

3 *I(a) A non-transitory computer readable medium comprising processing*  
4 *instructions which when executed by a data processor cause the data processor to*  
5 *perform a method for silencing notifications for incoming electronic messages to a*  
6 *communication system, the method comprising:* – Defendant makes and uses the  
7 Twitter application. Regardless of whether the preamble of claim 1 adds any  
8 substantive limitation to the claim, the claim language is met by the '120 Accused  
9 Products, as the '120 Accused Products include a non-transitory computer readable  
10 medium comprising processing instructions which when executed by a data  
11 processor cause the data processor to perform a method of silencing notifications for  
12 incoming electronic messages to a communication system as further described  
13 below for the remaining claim limitations.

14 *I(b) receiving one or more selected message threads for silencing; –*  
15  
16  
17  
18  
19  
20  
21  
22  
23  
24  
25  
26  
27  
28

1  
2  
3  
4  
5  
6  
7  
8  
9  
10  
11  
12  
13  
14  
15  
16  
17  
18  
19  
20  
21  
22  
23  
24  
25  
26  
27  
28

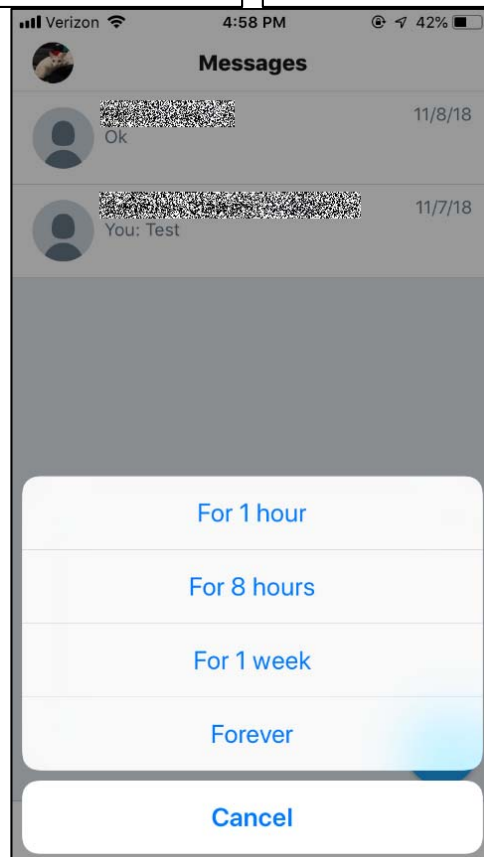
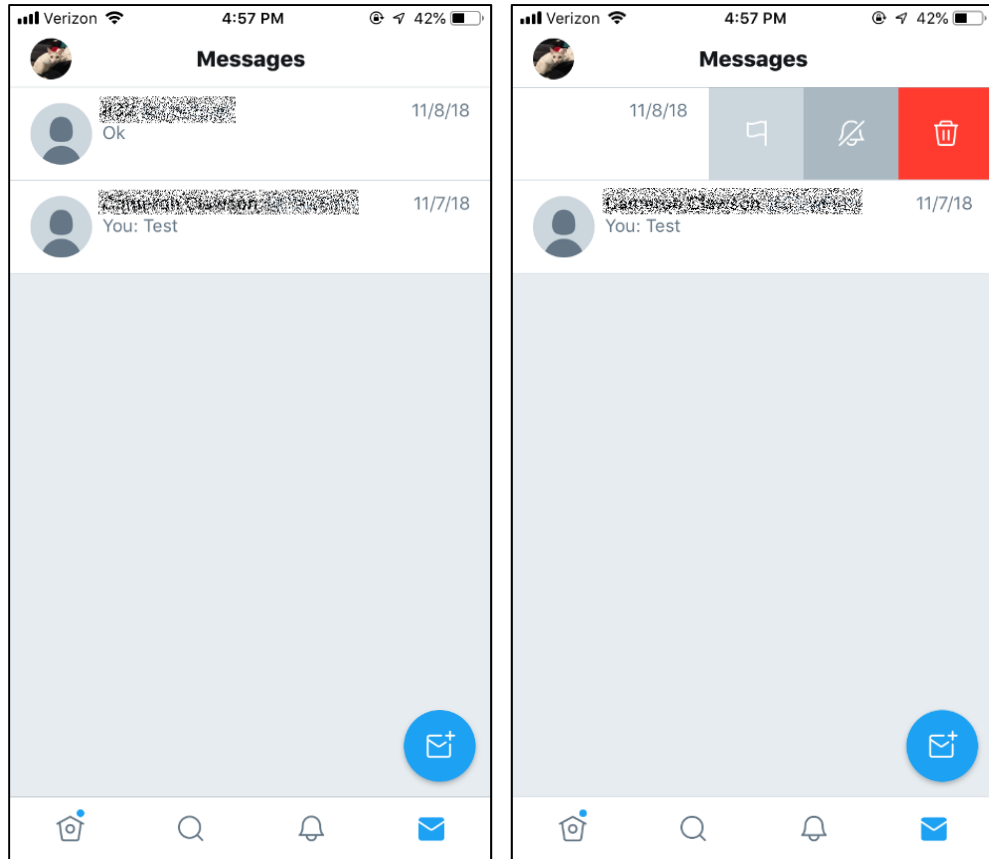



1 See also [https://www.igeeksblog.com/how-to-mute-twitter-direct-message-](https://www.igeeksblog.com/how-to-mute-twitter-direct-message-notifications-on-iphone-android-pc/)  
2 [notifications-on-iphone-android-pc/](https://www.igeeksblog.com/how-to-mute-twitter-direct-message-notifications-on-iphone-android-pc/); [https://help.twitter.com/en/using-twitter/direct-](https://help.twitter.com/en/using-twitter/direct-messages#mute)  
3 [messages#mute](https://help.twitter.com/en/using-twitter/direct-messages#mute).

4 *1(c) in response to receiving the one or more selected message threads,*  
5 *activating one or more flags, each flag in association with a selected message*  
6 *thread of the one or more selected message threads, wherein the one or more flags*  
7 *indicate that the associated one or more selected message threads have been*  
8 *silenced; –*

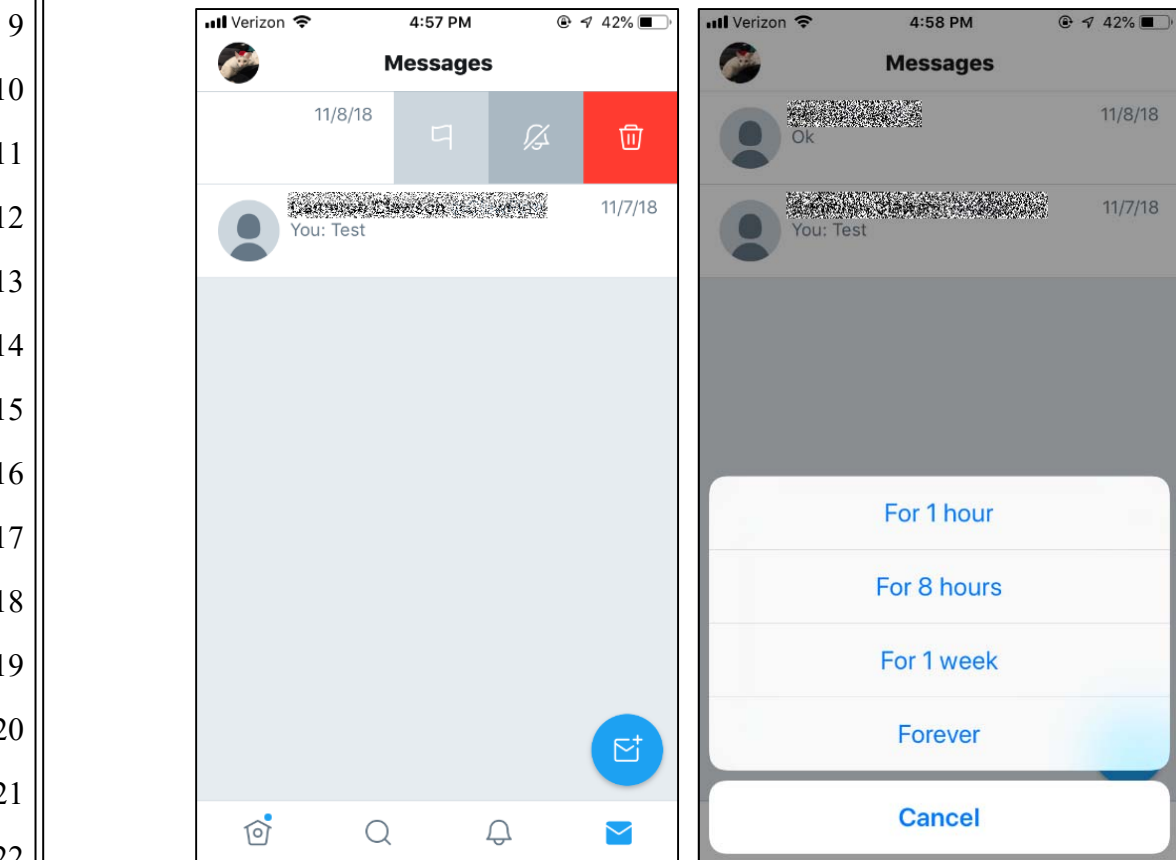

23 See also [https://www.igeeksblog.com/how-to-mute-twitter-direct-message-](https://www.igeeksblog.com/how-to-mute-twitter-direct-message-notifications-on-iphone-android-pc/)  
24 [notifications-on-iphone-android-pc/](https://www.igeeksblog.com/how-to-mute-twitter-direct-message-notifications-on-iphone-android-pc/); [https://help.twitter.com/en/using-twitter/direct-](https://help.twitter.com/en/using-twitter/direct-messages#mute)  
25 [messages#mute](https://help.twitter.com/en/using-twitter/direct-messages#mute).

26 *1(d) identifying the new incoming message as associated with the selected one*  
27 *or more message threads; determining that a message thread associated with the*  
28 *new incoming message has been flagged as silenced using the one or more flags; –*

1  
2  
3  
4  
5  
6  
7  
8  
9  
10  
11  
12  
13  
14  
15  
16  
17  
18  
19  
20  
21  
22  
23  
24  
25  
26  
27  
28

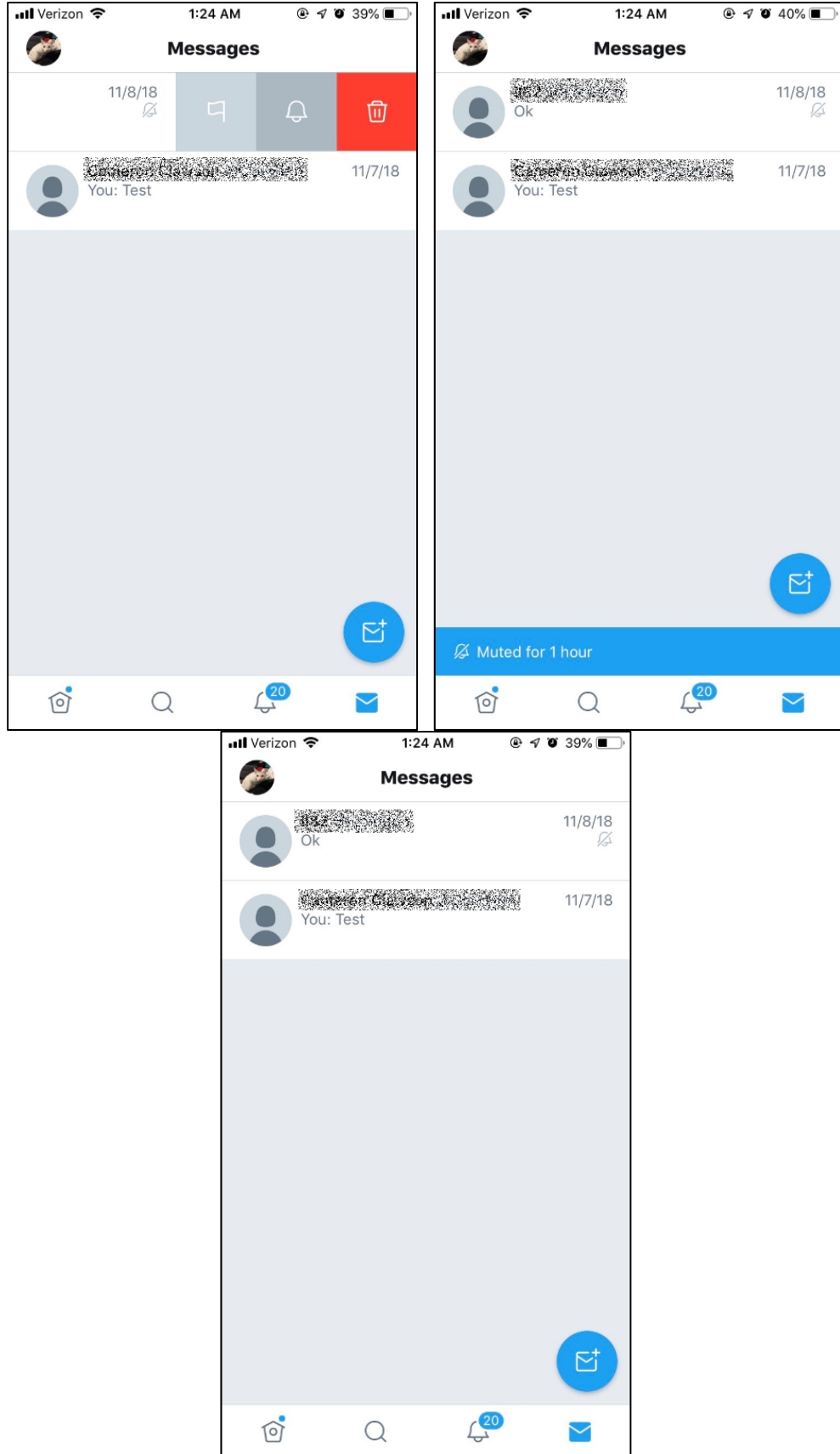

1 See also [https://www.igeeksblog.com/how-to-mute-twitter-direct-message-](https://www.igeeksblog.com/how-to-mute-twitter-direct-message-notifications-on-iphone-android-pc/)  
2 [notifications-on-iphone-android-pc/](https://www.igeeksblog.com/how-to-mute-twitter-direct-message-notifications-on-iphone-android-pc/); [https://help.twitter.com/en/using-twitter/direct-](https://help.twitter.com/en/using-twitter/direct-messages#mute)  
3 [messages#mute](https://help.twitter.com/en/using-twitter/direct-messages#mute).

4 *I(e) overriding at least one currently-enabled notification setting to prevent a*  
5 *notification pertaining to receipt of the new incoming message from being activated;*  
6 *and –*

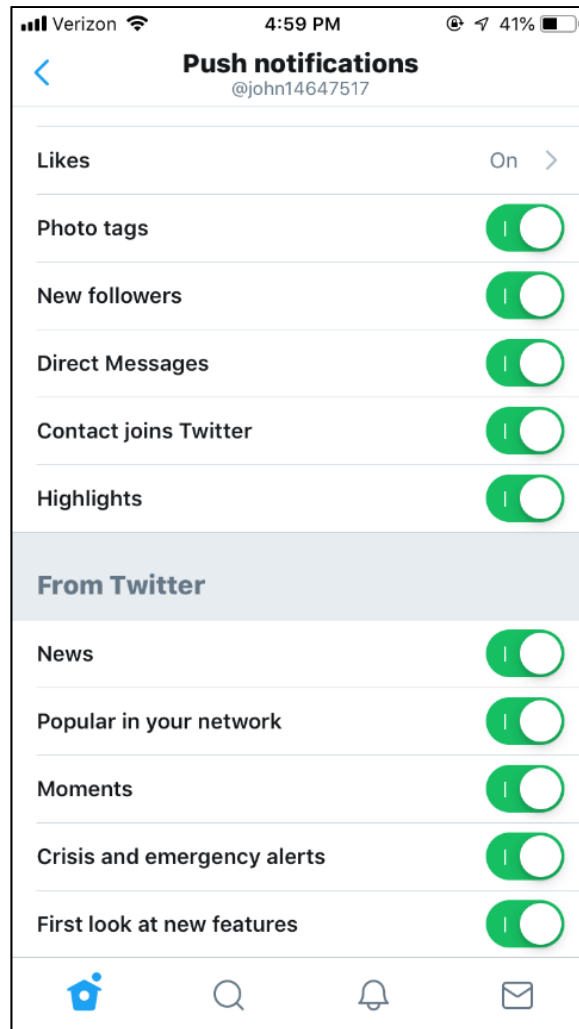

24 *I(f) wherein the new incoming message thread flagged as silenced is*  
25 *displayed in the inbox in a different manner than any message thread not flagged as*  
26 *silenced. –*  
27  
28

1  
2  
3  
4  
5  
6  
7  
8  
9  
10  
11  
12  
13  
14  
15  
16  
17  
18  
19  
20  
21  
22  
23  
24  
25  
26  
27  
28

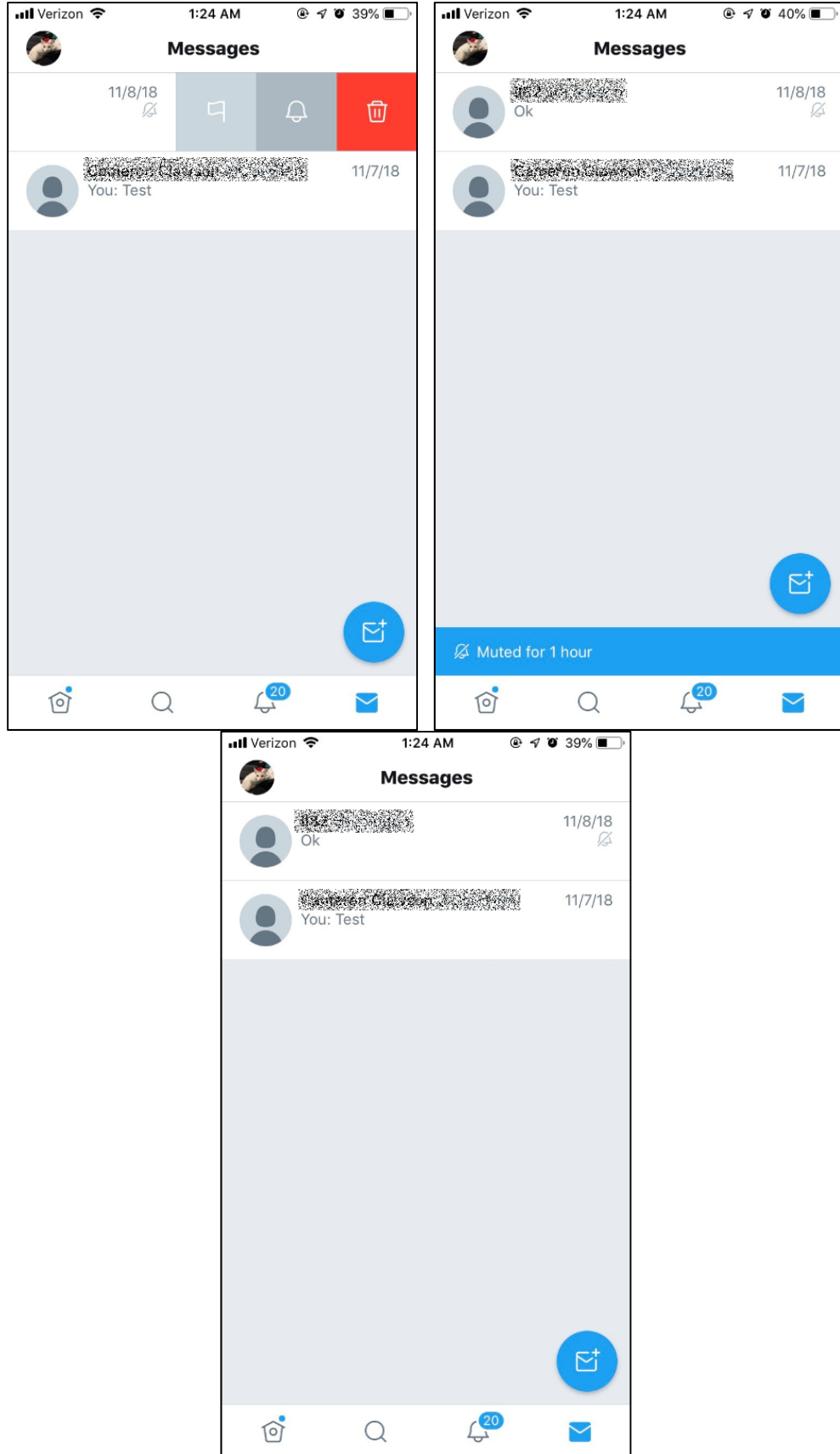

1 *See also* [https://www.igeeksblog.com/how-to-mute-twitter-direct-message-](https://www.igeeksblog.com/how-to-mute-twitter-direct-message-notifications-on-iphone-android-pc/)  
2 [notifications-on-iphone-android-pc/](https://help.twitter.com/en/using-twitter/direct-messages#mute); [https://help.twitter.com/en/using-twitter/direct-](https://help.twitter.com/en/using-twitter/direct-messages#mute)  
3 [messages#mute](https://help.twitter.com/en/using-twitter/direct-messages#mute).

4 114. Additionally, Defendant has been, and currently is, an active inducer of  
5 infringement of the '120 Patent under 35 U.S.C. § 271(b) and a contributory  
6 infringer of the '120 Patent under 35 U.S.C. § 271(c).

7 115. BlackBerry made Defendant aware of the '120 Patent and its  
8 infringement thereof by letter dated June 7, 2017. Ex. I. Accordingly, Defendant  
9 has had actual knowledge of (or was willfully blind to the existence of) the '120  
10 Patent and its infringement thereof at least as of June 7, 2017, but has failed to take  
11 any action to avoid infringement. Indeed, on information and belief, Defendant has  
12 released over two dozen new versions of the iOS Twitter application since being put  
13 on notice of its infringement—none of which removed the infringing functionality.  
14 (*See, e.g.*, <https://itunes.apple.com/in/app/twitter/id333903271?mt=8> (link to version  
15 history contained therein).) Accordingly, Defendant knew that it infringed the '120  
16 Patent well before BlackBerry filed this action and, despite its knowledge, acted  
17 egregiously and willfully by continuing to infringe the '120 Patent.

18 116. Defendant has provided the '120 Accused Products to its customers  
19 and, on information and belief, instructions to use the '120 Accused Products in an  
20 infringing manner while being on notice of or willfully blind to the '120 Patent and  
21 Defendant's infringement, and knowingly and intentionally encourages and aids its  
22 customers to directly infringe the '120 Patent.

23 117. Upon information and belief, Defendant provides the '120 Accused  
24 Products to customers through various third-party application stores (*e.g.*, the Apple  
25 App Store) and instructions to end-user customers so that such customers will use  
26 the '120 Accused Products in an infringing manner. For example, Defendant  
27 provides instructions to end-user customers on how to set up, configure, and use  
28

1 various features of the '120 Accused Products, as well as how to mute notifications  
2 associated with Twitter Direct Messaging conversations.<sup>8</sup>

3 118. Defendant's end-user customers directly infringe at least claims 1, 13,  
4 and 24 of the '120 Patent by using the '120 Accused Products in their intended  
5 manner to infringe. Defendant induces such infringement by providing the '120  
6 Accused Products and instructions to enable and facilitate infringement, knowing of,  
7 or being willfully blind to the existence of, the '120 Patent. Upon information and  
8 belief, Defendant specifically intends that its actions will result in infringement of at  
9 least claims 1, 13, and 24 of the '120 Patent, or subjectively believes that its actions  
10 will result in infringement of the '120 Patent but has taken deliberate actions to  
11 avoid learning of those facts, as set forth above.

12 119. Additionally, Defendant contributorily infringes at least claims 1, 13,  
13 and 24 of the '120 Patent by providing the '120 Accused Products and/or software  
14 components thereof, that embody a material part of the claimed inventions of the  
15 '120 Patent, that are known by Defendant to be specially made or adapted for use in  
16 an infringing manner, and are not staple articles with substantial non-infringing  
17 uses. The '120 Accused Products are specially designed to infringe at least claims  
18 1, 13, and 24 of the '120 Patent, and their accused components have no substantial  
19 non-infringing uses. In particular, on information and belief, the software modules  
20 and code that implement and perform the infringing functionalities identified above  
21 are specially made and adapted to carry out said functionality and do not have any  
22 substantial non-infringing uses.

23 120. Defendant's infringement of the '120 Patent was and continues to be  
24 willful and deliberate, entitling BlackBerry to enhanced damages and attorneys'  
25 fees.

26  
27 \_\_\_\_\_  
28 <sup>8</sup> See, e.g., <https://help.twitter.com/en/using-twitter/direct-messages#mute>.

1 121. Additional discovery regarding Defendant’s knowledge of the ’120  
2 Patent likely will uncover additional facts related to Defendant’s willful  
3 infringement.

4 122. Defendant’s infringement of the ’120 Patent is exceptional and entitles  
5 BlackBerry to attorneys’ fees and costs incurred in prosecuting this action under 35  
6 U.S.C. § 285.

7 123. BlackBerry has been damaged by Defendant’s infringement of the ’120  
8 Patent and will continue to be damaged unless Defendant is enjoined by this Court.  
9 BlackBerry has suffered and continues to suffer irreparable injury for which there is  
10 no adequate remedy at law. The balance of hardships favors BlackBerry, and public  
11 interest is not disserved by an injunction.

12 124. BlackBerry is entitled to recover from Defendant all damages that  
13 BlackBerry has sustained as a result of Defendant’s infringement of the ’120 Patent,  
14 including without limitation lost profits and not less than a reasonable royalty.

15 **COUNT IV: INFRINGEMENT OF U.S. PATENT NO. 9,021,059**

16 125. BlackBerry incorporates by reference and re-alleges all of the foregoing  
17 paragraphs of this First Amended Complaint as if fully set forth herein.

18 **The ’059 Patent**

19 126. The ’059 Patent discloses, among other things, an “[a]pparatus and  
20 methods to engage in accessing informational content in a data hub server, where  
21 the informational content is identified as public or partially public to a group  
22 registered in the data hub server with permission to access the informational content  
23 made public or partially public in the data hub server by another entity, provide a  
24 mechanism to enhance the communication capabilities among mobile electronic  
25 devices.” ’059 Patent, Abstract.

26 127. Claim 1, for example, embodies an improved communication system,  
27 in which a first mobile wireless device shares informational content with a second  
28 mobile wireless device using a data hub server. The data hub server receives in a

1 directed transmission a representation of the informational content from a first  
2 server, where the first mobile wireless device is a client of the first server. *Id.* at  
3 claim 1. The data hub server also notifies the availability of the informational  
4 content to the second mobile wireless device using a directed transmission to a  
5 second server, where the second mobile wireless device is a client of the second  
6 server. *Id.* Claims 2 and 3 teach that the steps of claim 1 further include  
7 transmitting the informational content from the first mobile wireless device to the  
8 first server. *Id.* at claims 2 and 3. The improved communication system therefore  
9 “reduce[s] the processing on the mobile electronic client devices” and “extend[s] the  
10 battery life of the mobile electronic client devices.” *Id.* at 18:5-12.

11 128. Indeed, the inventors of the '059 Patent recognized that  
12 “[i]mprovements to the flow of information enhance one’s ability to interact with  
13 others, to respond to changing needs, and to avail oneself of enjoyment from  
14 processing various media based information.” *Id.* at 1:11-14. Accordingly, in  
15 various embodiments, the inventors of the '059 Patent described this improvement  
16 in the context of server communications. *Id.* at 2:26-36. In particular, the '059  
17 Patent describes that “informational content sourced from a server can be accessed  
18 in a data hub server by another server in which the informational content is  
19 categorized in the data hub as public data with respect the accessing server. The  
20 informational content can be transferred to the data hub server from the server  
21 associated with the generation of the informational content using directed  
22 transmission between the server and the data hub server. The informational content  
23 can be transferred from the data hub server to the accessing server using directed  
24 transmission between the data hub server and the accessing server.” *Id.* The  
25 inventors therefore recognized that informational content could be shared by the  
26 user of a first device with the user of a second device without requiring the first user  
27 to download the content and upload it to a server that then transmits the content to  
28 the second user. Rather, by using a data hub server to notify the second user that the



1 informational content is available, the '059 Patent discloses a novel and improved  
 2 communications system that preserves system bandwidth and battery life of mobile  
 3 communications devices.

4 129. Figure 5, for example, illustrates a representative communications  
 5 system employing an embodiment of the '059 Patent “where mobile electronic  
 6 devices 510 and 530 are mobile wireless devices and servers 505 and 525 are  
 7 wireless servers.” *Id.* at 15:52-54. Mobile electronic devices 510 and 530 indicate  
 8 status of informational content, such as, for example, a set of movie clips, by  
 9 marking it public or non-public. *Id.* at 15:51-67, 16:38-39. A representation of the  
 10 informational content is sent from the mobile electronic devices 510 and 530 to  
 11 respective servers 505 and 525. *Id.* at 16:1-4. The transfer may occur via, for  
 12 example, Wi-Fi or USB. *Id.* at 16:1-37. In some embodiments, mobile electronic  
 13 device 510 may have a share registration in server 525 (and vice versa). *Id.* at 16:1-  
 14 4.

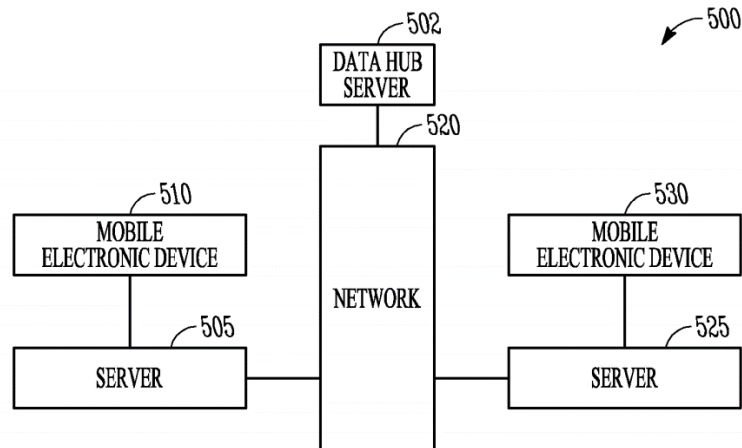

15  
16  
17  
18  
19  
20  
21  
22  
23 **FIG. 5**

24 *Id.* at Fig. 5.

25 130. The '059 Patent explains that “[u]pon receipt of the movie clips in  
 26 server 505, the status as to public or non-public is checked in server 505. The  
 27 determination of which users have access to the movie clips can have been made in  
 28 data hub server 502 previous to the reception of the movie clips in server 505. In

1 such a case, server 505 sends the movie clips to data hub server 502 in appropriate  
2 format for transmission upon checking and determining the public status.” *Id.* at  
3 16:38-45. A user registers in data hub server 502 or servers 505, 525 using a mobile  
4 electronic device (*e.g.*, 510, 530). *Id.* at 16:56-17:8. If marked with a public status,  
5 the informational content can be made available to mobile devices on the data hub  
6 server 502. *Id.* at 16:56-17:28.

7 131. In various embodiments of the ’059 Patent, servers send notifications to  
8 mobile electronic devices that are registered clients. For example, upon receipt of  
9 informational content received at a server, the server sends notification of the arrival  
10 of the informational content to a mobile electronic device. *Id.* at 23:15-32. In  
11 response, the mobile electronic device requests to download (or automatically  
12 downloads) the informational content in response to the notification. *Id.*

13 132. The ’059 Patent thus describes, among other things, “[a] method  
14 comprising making informational content, selected in a first mobile wireless device,  
15 available to a second mobile wireless device using a data hub server; receiving a  
16 representation of the informational content in the data hub server in a directed  
17 transmission from a first server to the data hub server, the first mobile wireless  
18 device being a client of the first server; and transmitting notification of the  
19 informational content being available to the second mobile wireless device using a  
20 directed transmission from the data hub server to a second server, the second mobile  
21 wireless device being a client of the second server, the first server being separate  
22 from the second server.” *Id.* at claim 1.

23 133. The ’059 Patent discloses a specific technological architecture,  
24 including a first server, a data hub server, and a second server communicating  
25 representational information using directed transmissions over a network. This non-  
26 abstract configuration of hardware and software is focused on the concrete problem  
27 identified in the specification. Against that backdrop, the claims here teach an  
28 improved technical architecture that results in eliminating the need for a first mobile

1 wireless device to upload content to be shared with a second mobile wireless device,  
2 resulting in bandwidth savings as well as improved battery life on the first mobile  
3 wireless device.

4 **The Inventions Claimed in the '059 Patent Were Not**  
5 **Well-Understood, Routine, or Conventional**

6 134. The method of making informational content, selected in a first mobile  
7 wireless device, available to a second mobile wireless device using a data hub  
8 server, whereby the server receives a representation of the informational content  
9 from a first server and transmits a notification of the informational content being  
10 available to the second mobile wireless device using a directed transmission from  
11 the data hub server to a second server, was not common or conventional at the time  
12 of the '059 Patent.

13 135. The inventors of '059 Patent recognized that, in systems that manage  
14 media content accessible to mobile electronic devices, “[i]mprovements to the flow  
15 of information enhance one’s ability to interact with others, to respond to changing  
16 needs, and to avail oneself of enjoyment from processing various media based  
17 information.” '059 Patent at 1:11-14. The '059 Patent further describes that “using  
18 servers, in connection with a data hub server, to manage the transfer of  
19 informational content between mobile electronic client devices can reduce the  
20 processing on the mobile electronic client devices with respect to the administration  
21 aspects of the data transmission and extend the battery life of the mobile electronic  
22 client devices.” *Id.* at 18:6-12.

23 136. The inventors recognized that mobile wireless clients with shared  
24 registration of a data hub server provides the benefit of “efficient transfer of  
25 informational among such mobile wireless clients of different wireless servers  
26 without the mobile wireless clients having a share registration in the same wireless  
27 server.” *Id.* at 18:13-19. In this manner, the '059 Patent is able to strike a desirable  
28

1 balance between cost efficiency and convenient access to informational content.  
2 18:3-12.

3 137. Given the state of the art at the time of the invention of the '059 Patent,  
4 the inventive concepts of the '059 Patent were not conventional, well-understood, or  
5 routine. The '059 Patent discloses, among other things, an unconventional  
6 technological solution to an issue arising specifically in the context of electronic  
7 communications systems and electronic messaging and information exchange  
8 between mobile electronic devices within those systems. The solution implemented  
9 by the '059 Patent provides a specific and substantial improvement over prior  
10 electronic messaging systems in electronic devices, including by introducing novel  
11 elements directed to improving the function and working of communications  
12 devices such as, among other things, the claimed “making informational content,  
13 selected in a first mobile wireless device, available to a second mobile wireless  
14 device using a data hub server” (claims 1, 11, and 16), “receiving a representation of  
15 the informational content in the data hub server in a directed transmission from a  
16 first server to the data hub server, the first mobile wireless device being a client of  
17 the first server” (same), and “transmitting notification of the informational content  
18 being available to the second mobile wireless device using a directed transmission  
19 from the data hub server to a second server, the second mobile wireless device being  
20 a client of the second server, the first server being separate from the second server”  
21 (same).

22 138. Consistent with the problem addressed being rooted in electronic  
23 messaging and information exchange between wireless communications devices, the  
24 '059 Patent's solutions naturally are also rooted in the same technology that cannot  
25 be performed with pen and paper or in the human mind.

26 139. This technical context is reflected in the '059 Patent's claims. For  
27 example, various claims of the '059 Patent require first and second mobile wireless  
28

1 devices, a data hub server, first and second servers, electronic informational content,  
2 and directed transmissions between servers.

3 140. A person having ordinary skill in the art at the time of the inventions of  
4 the '059 Patent would not have understood that the inventions could or would be  
5 performed solely in the human mind or using pen and paper. Using pen and paper  
6 would ignore the stated purpose of the '059 Patent and the problem it was  
7 specifically designed to address. Doing so would also run counter to the inventors'  
8 detailed description of the inventions and the language of the claims and be a  
9 practical impossibility.

#### 10 **'059 Patent Allegations**

11 141. Defendant has infringed and is infringing, either literally or under the  
12 doctrine of equivalents, the '059 Patent in violation of 35 U.S.C. § 271 *et seq.*,  
13 directly, by making, using, selling, offering for sale, and/or importing into the  
14 United States without authority or license, the Twitter application and associated  
15 backend servers and systems (hereinafter "the '059 Accused Products") that  
16 infringes at least claim 1, 11, and 16 of the '059 Patent.

17 142. On information and belief after reasonable investigation, the '059  
18 Accused Products contain messaging and information exchange functionality  
19 designed and used to exchange information by transmitting a representation of  
20 content to a data hub server that then provides a notification to one or more  
21 recipients of availability of the content in an infringing manner.

22 143. As just one non-limiting example, set forth below (with claim language  
23 in italics) is a description of infringement of exemplary claim 1 of the '059 Patent in  
24 connection with the Twitter application and associated backend servers and systems.  
25 This description is based on publicly available information. BlackBerry reserves the  
26 right to modify this description, including, for example, on the basis of information  
27 about the '059 Accused Products that it obtains during discovery.

28

1 *I(a) A method comprising:* – Defendant makes and uses the Twitter  
 2 application. Regardless of whether the preamble of claim 1 adds any substantive  
 3 limitation to the claim, the claim language is met by the '059 Accused Products, as  
 4 the '059 Accused Products perform a method as further described below for the  
 5 remaining claim limitations.

6 *I(b) making informational content, selected in a first mobile wireless device,*  
 7 *available to a second mobile wireless device using a data hub server;* – For  
 8 example, on information and belief, a Twitter data hub server makes informational  
 9 content selected by a Twitter user’s mobile wireless device, such as a tweet or  
 10 advertisement to retweet, available to a second mobile wireless device, such as the  
 11 Twitter user’s followers.

12 **Retweet FAQs**  
 13 **What is a Retweet?**

- 14 • A Retweet is a re-posting of a Tweet. **Twitter's**  
 15 **Retweet feature helps you and others quickly share**  
 16 **that Tweet with all of your followers.** You can Retweet  
 17 your own Tweets or Tweets from someone else.
- 18 • Sometimes people type "RT" at the beginning of a  
 19 Tweet to indicate that they are re-posting someone  
 20 else's content. This isn't an official Twitter command  
 21 or feature, but signifies that they are quoting another  
 22 person's Tweet.

23 **What does a Retweet look like?**

- 24 • Retweets look like normal Tweets with the author's  
 25 name and username next to it, but are distinguished  
 26 by the **Retweet** icon  and the name of the person  
 27 who Retweeted the Tweet. If you see content from  
 28 someone you do not follow in your timeline, look for  
**Retweeted by** info in the Tweet—the Retweeter  
 should be someone you follow.

29 <https://help.twitter.com/en/using-twitter/retweet-faqs>; *see also*  
 30 [http://www.timdeboer.eu/paper\\_publishing/Twitter\\_An\\_Architectural\\_Review.pdf](http://www.timdeboer.eu/paper_publishing/Twitter_An_Architectural_Review.pdf).

1  
2  
3  
4  
5  
6  
7  
8  
9  
10  
11  
12  
13  
14  
15  
16  
17  
18  
19  
20  
21  
22  
23  
24  
25  
26  
27  
28

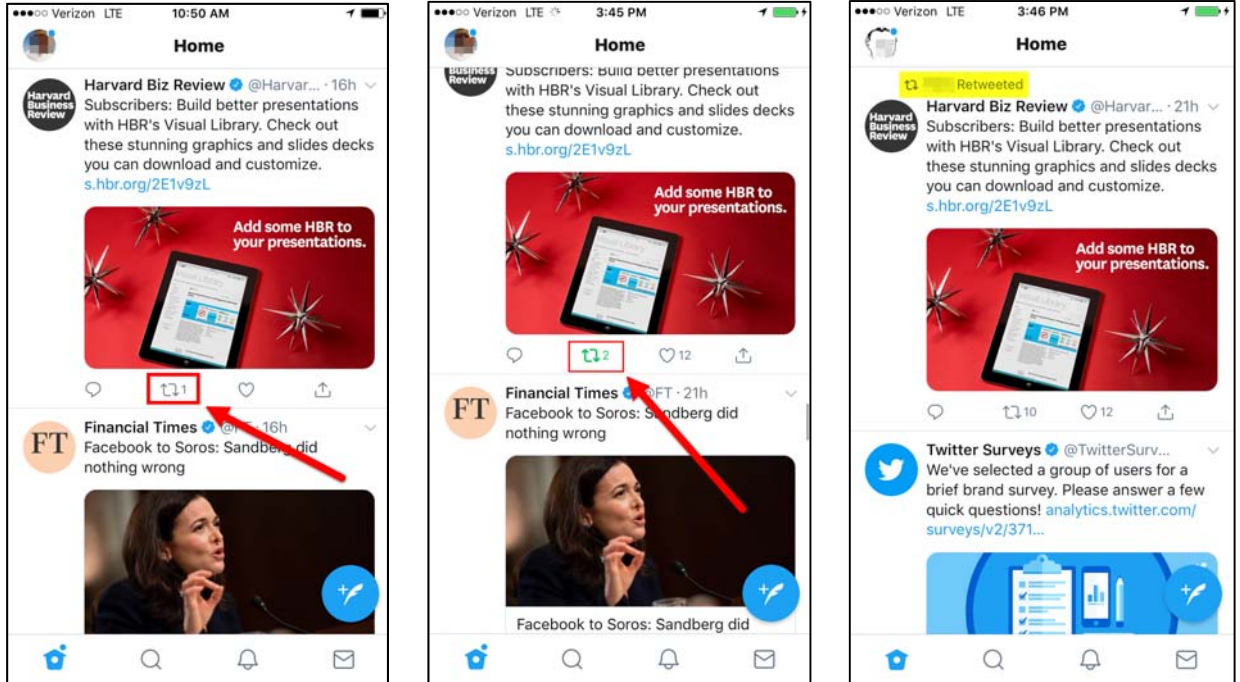

*I(b) receiving a representation of the informational content in the data hub server in a directed transmission from a first server to the data hub server, the first mobile wireless device being a client of the first server; and – For example, on information and belief, when a Twitter user retweets content, a Twitter data hub server receives a representation of that informational content via a directed transmission from a first server (e.g., the user’s Internet service provider). See, e.g., [https://blog.twitter.com/engineering/en\\_us/topics/infrastructure/2017/the-infrastructure-behind-twitter-scale.html](https://blog.twitter.com/engineering/en_us/topics/infrastructure/2017/the-infrastructure-behind-twitter-scale.html); <http://highscalability.com/blog/2013/7/8/the-architecture-twitter-uses-to-deal-with-150m-active-users.html>; <https://www.infoq.com/presentations/Twitter-Timeline-Scalability>.*

*I(c) transmitting notification of the informational content being available to the second mobile wireless device using a directed transmission from the data hub server to a second server, the second mobile wireless device being a client of the second server, the first server being separate from the second server. – For example, on information and belief, Defendant transmits a notification of the informational content being available (e.g., the first user’s tweet or retweet) to the followers of the*

1 first user, including a second user, via a directed transmission from the Twitter data  
2 hub server to a second server, e.g., the followers' respective transport POP servers  
3 and/or edge POP servers, including of the second user.  
4 [https://blog.twitter.com/engineering/en\\_us/topics/infrastructure/2017/the-](https://blog.twitter.com/engineering/en_us/topics/infrastructure/2017/the-infrastructure-behind-twitter-scale.html)  
5 [infrastructure-behind-twitter-scale.html](https://blog.twitter.com/engineering/en_us/topics/infrastructure/2017/the-infrastructure-behind-twitter-scale.html). The notification is a push notification  
6 displayed via the Twitter application on the second user's mobile device.

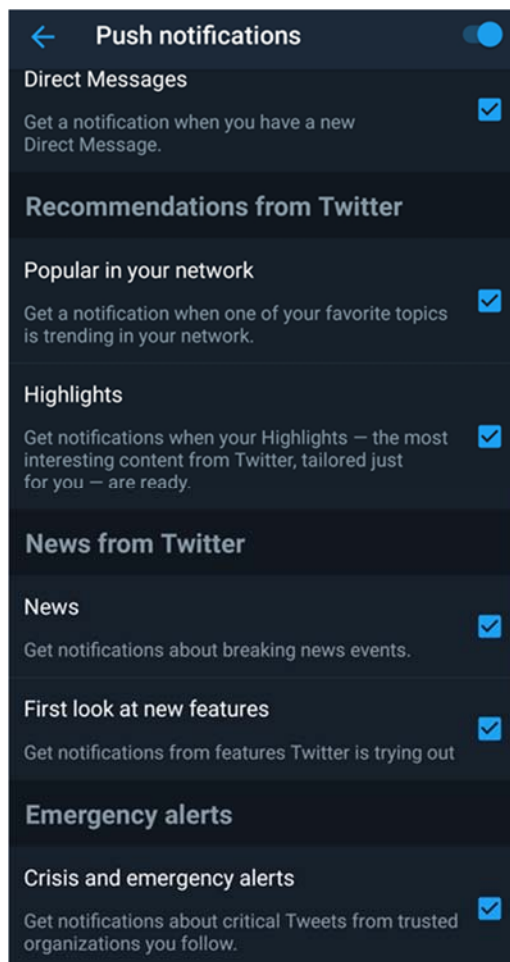
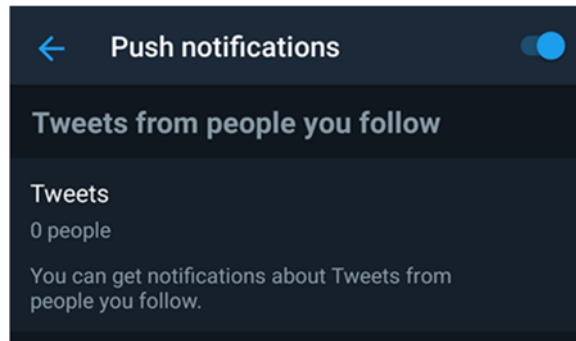



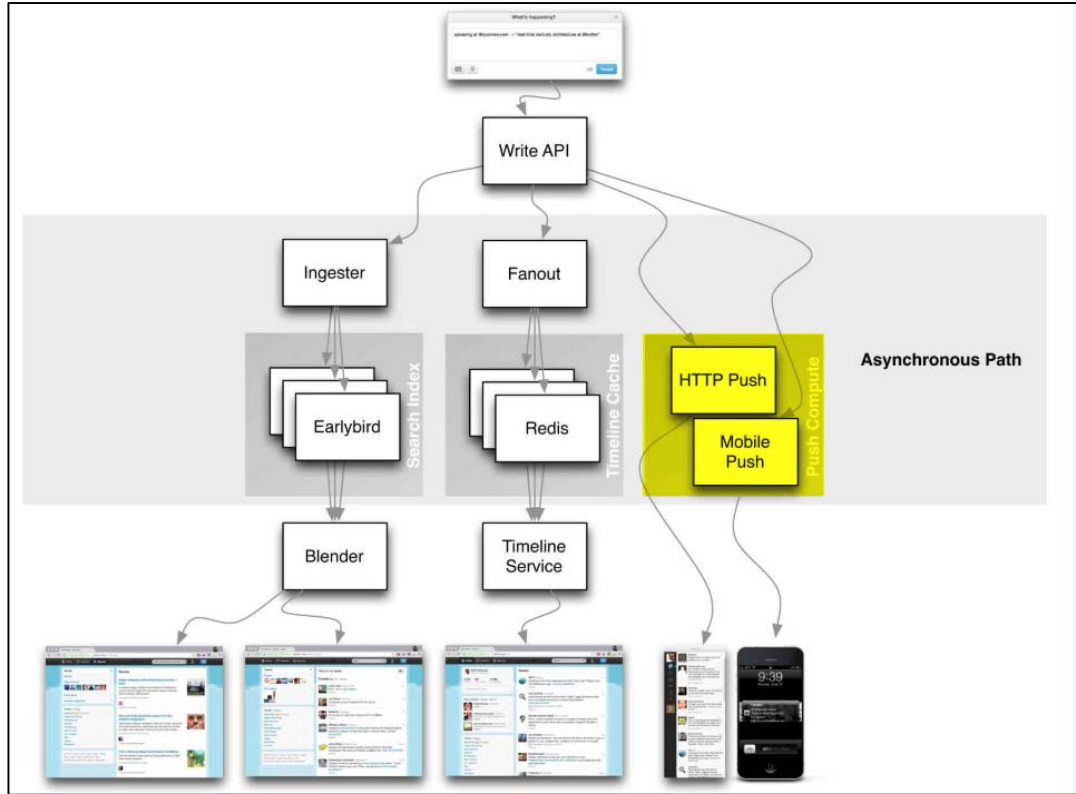

<https://www.infoq.com/presentations/Twitter-Timeline-Scalability>; *see also*  
<https://www.infoq.com/news/2009/06/Twitter-Architecture>;  
<https://blog.evanweaver.com/2009/03/13/qcon-presentation/>;  
[http://www.timdeboer.eu/paper\\_publishing/Twitter\\_An\\_Architectural\\_Review.pdf](http://www.timdeboer.eu/paper_publishing/Twitter_An_Architectural_Review.pdf);  
[https://blog.twitter.com/engineering/en\\_us/topics/infrastructure/2017/the-infrastructure-behind-twitter-scale.html](https://blog.twitter.com/engineering/en_us/topics/infrastructure/2017/the-infrastructure-behind-twitter-scale.html); <http://highscalability.com/blog/2013/7/8/the-architecture-twitter-uses-to-deal-with-150m-active-users.html>;  
<https://www.infoq.com/presentations/Twitter-Timeline-Scalability>.

144. BlackBerry has been damaged by Defendant’s infringement of the ’059 Patent and will continue to be damaged unless Defendant is enjoined by this Court. BlackBerry has suffered and continues to suffer irreparable injury for which there is no adequate remedy at law. The balance of hardships favors BlackBerry, and public interest is not disserved by an injunction.

1 145. BlackBerry is entitled to recover from Defendant all damages that  
2 BlackBerry has sustained as a result of Defendant’s infringement of the ’059 Patent,  
3 including without limitation lost profits and not less than a reasonable royalty.

4 **COUNT V: INFRINGEMENT OF U.S. PATENT NO. 8,286,089**

5 146. BlackBerry incorporates by reference and re-alleges all of the foregoing  
6 paragraphs of this First Amended Complaint as if fully set forth herein.

7 **The ’089 Patent**

8 147. The ’089 Patent discloses, among other things, “a method of  
9 representing new email messages on a communication device having a display. This  
10 method comprises setting a new message flag when an email message is received by  
11 the device; and displaying a new message indicator on the display when the new  
12 message flag is set. The new message indicator can be displayed on a home screen  
13 on the display. The new message flag can be unset when a messages screen is  
14 selected on the device. A computer readable memory having recorded thereon  
15 instructions to carry out this method is also provided, as well as a device comprising  
16 such memory.” ’089 Patent, Abstract.

17 148. The patent explains—against the technological backdrop in 2005, when  
18 the inventions claimed in the ’089 Patent were conceived and reduced to practice—  
19 that exchanging messages on wireless and mobile devices had become “an  
20 increasingly important feature” and such “messages received by the device [were]  
21 typically viewed using a graphical user interface (GUI).” *Id.* at 1:34-39. In prior art  
22 user interfaces, the user was notified of all new unopened messages using a counter  
23 on the home screen. *Id.* at 1:39-51. But “[m]any device users receive far too many  
24 email messages for a simple unopened counter to be of much use. The number of  
25 unopened emails becomes so large that the count itself is largely irrelevant. These  
26 users need some way to be informed that they have new messages as distinct from  
27 unopened messages on the device.” *Id.* at 1:52-57. An improved user interface was  
28 thus needed on such devices.

1           149. The prior art approach of requiring users to open each and every one of  
2 their new messages before clearing a new message indicator was computationally  
3 expensive and inconvenient. For example, all new, unopened messages on prior art  
4 communications devices needed to be opened or “read” before a new message  
5 indicator was reset. This resulted in unnecessary use of the device processor and  
6 concomitant increased battery use. The invention of the ’089 Patent, on the other  
7 hand, teaches an improved communication device that can reset a new message  
8 indicator without requiring each of the new, unopened messages being opened—  
9 thereby freeing processing power on the communication device and saving battery  
10 life.

11           150. The ’089 Patent explains that “[s]ending and receiving data messages,  
12 particularly email, on wireless mobile devices has become an increasingly important  
13 feature. Email messages received by the device are typically viewed using a  
14 graphical user interface (GUI), accessing a messages screen displayed on the  
15 device's display.” *Id.* at 1:34-39. The ’089 Patent further explains that “[a  
16 respective icon may be presented in association with each individual message in the  
17 message list indicating whether the particular message has been opened or  
18 unopened,” and “[a] counter indicating the number of unopened messages present  
19 on the device may be displayed to the user such as on a home screen of the device.”  
20 *Id.* at 1:41-51. However, the ’089 Patent recognized that “[m]any device users  
21 receive far too many email messages for a simple unopened counter to be of much  
22 use.” *Id.* at 1:52-57. To better inform users, some embodiments of the ’084 Patent  
23 provide a presentation of new messages and a notification that a new message has  
24 been received on a communications device. *Id.* at 3:6-36. In particular, when a new  
25 message is received, a new message indicator is shown on the home screen of the  
26 device or application. *Id.* This indicator is reset as soon as the device switches from  
27 the home screen to a display that contains a listing of received messages and a  
28

1 preview of the newly received message (e.g., by displaying a portion of the  
2 message). *Id.*

3 151. The '089 Patent explains further, “[i]n one embodiment, when there is a  
4 new message received by the device, the device turns on a new message flag. When  
5 the new message flag is on, the new messages indicator (e.g. 612 or LED) may be  
6 displayed. The new message flag can be turned off such as when the messages  
7 screen for displaying the message list is invoked or, in other embodiments, when all  
8 individual new messages are determined to be old messages.” *Id.* at 3:37-43.

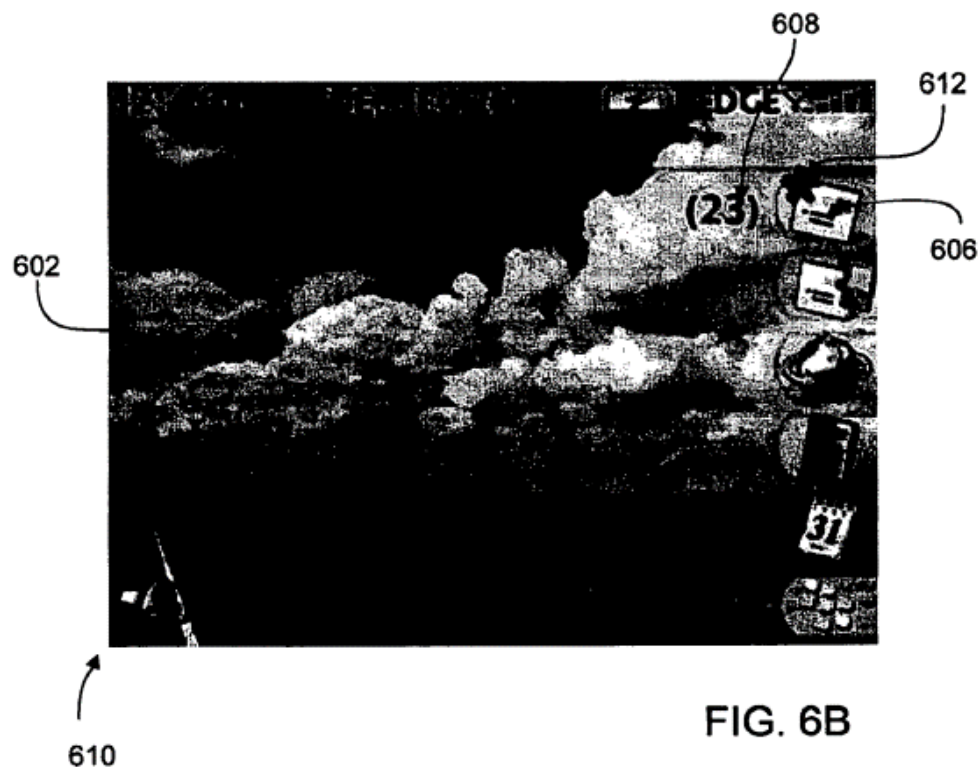

22 *Id.* at Fig. 6B.

23 152. The '089 Patent provides “[d]isplay screen activity of the GUI is  
24 described for representing the new message indicator (e.g. 612). In accordance with  
25 the GUI, the user may navigate about a plurality of screens for example, moving  
26 from a home or main screen to display screens of various applications or functions  
27 such as an address book, messages screen displaying a list of email messages,  
28 calendar, phone dialler [sic], Web browser, etc.” *Id.* at 7:23-30.

1 153. Figure 4B, for example, illustrates representative invocation operations  
 2 by which the patent enables a new messages indicator. In step 416, one display  
 3 screen is invoked. *Id.* at 7:34-35. Either a home screen (602) or “a messages screen  
 4 (not shown) for reviewing email messages and opening (reading) email for  
 5 example.” *Id.* at 7:34-37. The home screen displays a new messages indicator  
 6 based on whether there are new messages (step 418). *Id.* at 7:40-47. In other words,  
 7 the home screen displays the new messages indicator until the messages screen is  
 8 invoked, at which time the user is aware of the new messages. *Id.* The ’089 Patent  
 9 further explains that “when the messages screen is invoked (such as by user  
 10 selection), the messages screen is displayed (Step 424) and operations unset (e.g.  
 11 turn off) the message indicator flag (Step 426). When the home screen 602 is  
 12 accessed again before a new message arrives on the device 202, the home screen  
 13 602 will not display the new messages indicator 612.” *Id.* at 7:48-53.

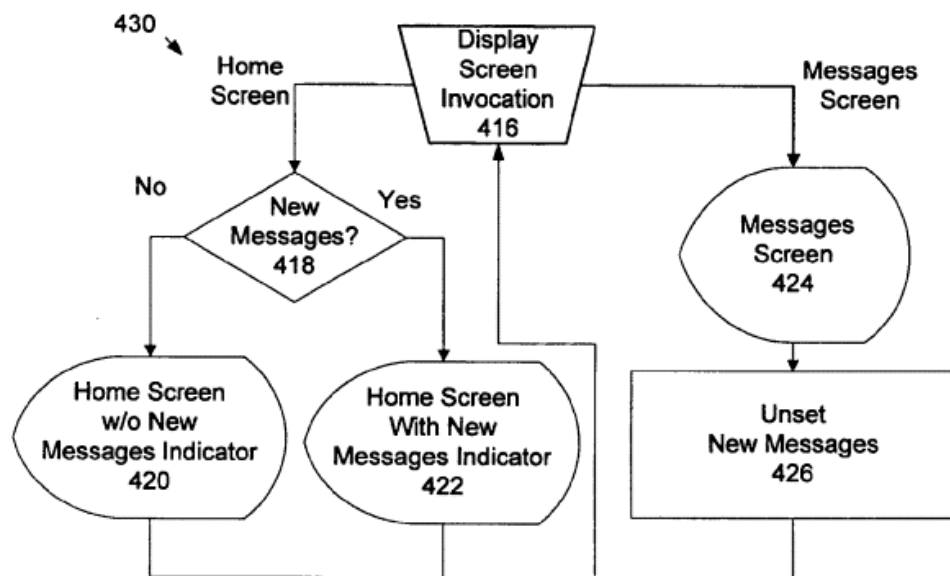

FIG. 4B

25 *Id.* at Fig. 4B.

26 154. The ’089 Patent thus describes, among other things, “[a] method of  
 27 representing new electronic messages on a communication device having a display,  
 28 the method comprising: receiving a new electronic message, setting a new message

1 flag to indicate receipt of the new electronic message, representing, on a home  
2 screen displayed on the display, a new message indicator when the new message  
3 flag is set, receiving an invocation to switch the home screen displayed on the  
4 display to a message inventory display screen for viewing a listing including a  
5 plurality of electronic messages including the new electronic message, the message  
6 inventory display screen displaying a preview, for each listed electronic message, of  
7 either a subject line or of a portion of contents of the electronic message, the  
8 contents of an electronic message being accessible upon receipt of a request to open  
9 an electronic message from the list of messages, unsetting the new message flag in  
10 response to the invocation to switch the home screen displayed on the display to the  
11 message inventory display screen, the unsetting of the flag occurring without having  
12 received a request to open the new electronic message, and receiving an invocation  
13 to switch the message inventory display screen to the home screen, wherein the new  
14 message indicator represented on the home screen is not displayed as a result of the  
15 unsetting of the new message flag.” *Id.* at claim 1.

16 **The Inventions Claimed in the '089 Patent Were Not**  
17 **Well-Understood, Routine, or Conventional**

18 155. A communication device having a display to set a new message flag to  
19 indicate receipt of a new electronic message, representing on a home screen  
20 displayed on the display a new message indicator when the new message flag is set,  
21 receiving invocation to switch the home screen displayed on the display to a  
22 message inventory display screen for viewing a listing including a plurality of  
23 electronic messages including the new electronic message, unsetting the new  
24 message flag in response to the invocation to switch the home screen to the message  
25 inventory display screen, and receiving an invocation to switch the message  
26 inventory display screen to the home screen, wherein the new message indicator  
27 represented on the home screen is not displayed as a result of the unsetting of the  
28

1 new message flag, was not common or conventional at the time of the invention of  
2 the '089 Patent.

3 156. The inventors of the '089 Patent recognized that wireless and mobile  
4 communication devices, such as cellular phones, were increasingly popular for  
5 sending and receiving electronic messages. '089 Patent at 1:22-36. These messages  
6 were “typically presented in a message list showing limited information pertaining  
7 to each message,” and respective icons indicated whether a particular message had  
8 been opened or unopened. *Id.* at 1:39-45. Further, at the time of invention, “[a]  
9 counter indicating the number of unopened messages present on the device may be  
10 displayed to the user such as on a home screen of the device.” However, the  
11 inventors of the '089 Patent recognized that “[m]any device users receive far too  
12 many email messages for a simple unopened counter to be of much use. The number  
13 of unopened emails becomes so large that the count itself is largely irrelevant.” *Id.*  
14 at 1:52-55. The inventors therefore recognized that “[t]hese users need some way to  
15 be informed that they have new messages as distinct from unopened messages on  
16 the device.” *Id.* at 1:56-57.

17 157. The inventors of the '089 Patent recognized the benefit of solving this  
18 described problem by providing an improved and more efficient electronic device in  
19 which, among other things, a new message indicator is displayed on the home  
20 screen of the device or application when a new message is received until a user  
21 invokes the message inventory screen displaying all messages including the new  
22 message, whereby the switch from the home screen to the inventory screen resets  
23 the new message indicator. The display of the new message indicator is thereby  
24 tailored to the user’s knowledge of new messages.

25 158. Given the state of the art at the time of the invention of the '089 Patent,  
26 the inventive concepts of the '089 Patent were not conventional, well-understood, or  
27 routine. The '089 Patent discloses, among other things, an unconventional and  
28 technological solution to an issue arising specifically in the context of electronic

1 communications systems and electronic messaging received within those  
2 communications systems. The solution implemented by the '089 Patent provides a  
3 specific and substantial improvement over prior messaging notification systems,  
4 resulting in an improved electronic communication system, including by introducing  
5 novel elements directed to improving the function and working of communications  
6 systems such as, among other things, the claimed “setting a new message flag to  
7 indicate receipt of the new electronic message,” (claim 1), “receiving an invocation  
8 to switch the home screen displayed on the display to a message inventory display  
9 screen for viewing a listing including a plurality of electronic messages including  
10 the new electronic message, the message inventory display screen displaying a  
11 preview, for each listed electronic message, of either a subject line or of a portion of  
12 contents of the electronic message, the contents of an electronic message being  
13 accessible upon receipt of a request to open an electronic message from the list of  
14 messages;” (same), “unsetting the new message flag in response to the invocation to  
15 switch the home screen displayed on the display to the message inventory display  
16 screen, the unsetting of the flag occurring without having received a request to open  
17 the new electronic message” (same), and “receiving an invocation to switch the  
18 message inventory display screen to the home screen, wherein the new message  
19 indicator represented on the home screen is not displayed as a result of the unsetting  
20 of the new message flag” (same).

21 159. Consistent with the problem addressed being rooted in electronic  
22 messaging between wireless communications devices, the '089 Patent's solutions  
23 naturally are also rooted in the same technology that cannot be performed with pen  
24 and paper or in the human mind.

25 160. This technical context is reflected in the '089 Patent's claims. For  
26 example, various claims of the '089 Patent require a communications device having  
27 a display, a home screen displayed on the display, a message inventory display  
28 screen displayed on the display, a new electronic message, and a new message flag.



1 Further, various claims of the '089 Patent require a communications device having a  
2 processor, memory, configured to receive a new electronic message, display a new  
3 message indicator on a home screen, and receive invocations to switch to different  
4 display screens.

5 161. A person having ordinary skill in the art at the time of the inventions of  
6 the '089 Patent would not have understood that the inventions could or would be  
7 performed solely in the human mind or using pen and paper. Using pen and paper  
8 would ignore the stated purpose of the '089 Patent and the problem it was  
9 specifically designed to address. Doing so would also run counter to the inventors'  
10 detailed description of the invention and the language of the claims and be a  
11 practical impossibility.

#### 12 **'089 Patent Allegations**

13 162. Defendant has infringed and is infringing, either literally or under the  
14 doctrine of equivalents, the '089 Patent in violation of 35 U.S.C. § 271 *et seq.*,  
15 directly and/or indirectly, by making, using, selling, offering for sale, and/or  
16 importing into the United States without authority or license, the Twitter application  
17 (hereinafter "the '089 Accused Products") that infringes at least claim 1 of the '089  
18 Patent.

19 163. On information and belief after reasonable investigation, the '089  
20 Accused Products contain messaging functionality designed and used to display a  
21 new message indicator upon receipt of a new message, display a message inventory  
22 screen, and affect the display of the new message indicator based on switching from  
23 a home screen to the message inventory screen in an infringing manner.

24 164. As just one non-limiting example, set forth below (with claim language  
25 in italics) is a description of infringement of exemplary claim 1 of the '089 Patent in  
26 connection with the Twitter application. This description is based on publicly  
27 available information. BlackBerry reserves the right to modify this description,  
28

1 including, for example, on the basis of information about the '089 Accused Products  
 2 that it obtains during discovery.

3 *1(a) A method of representing new electronic messages on a communication*  
 4 *device having a display, the method comprising:* – Defendant makes and uses the  
 5 Twitter application. Regardless of whether the preamble of claim 1 adds any  
 6 substantive limitation to the claim, the claim language is met by the '089 Accused  
 7 Products, as the '089 Accused Products perform a method of representing new  
 8 electronic messages on a communication device having a display as further  
 9 described below for the remaining claim limitations.

10 *1(b) receiving a new electronic message; 1(c) setting a new message flag to*  
 11 *indicate receipt of the new electronic message;* – On information and belief, the  
 12 Twitter application receives new direct messages and sets a new message flag to  
 13 indicate receipt of said new direct messages.

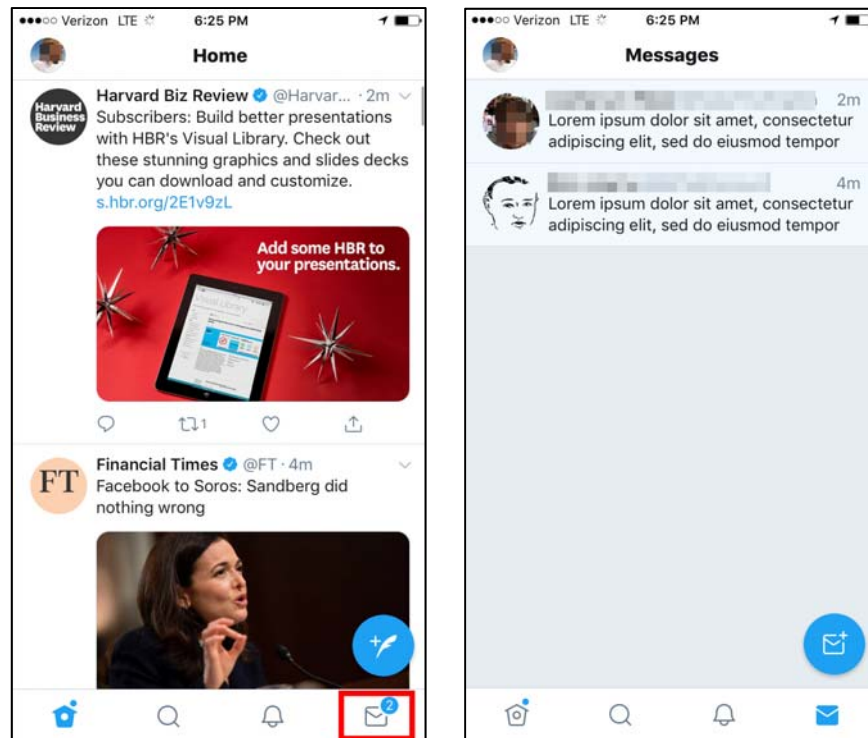

26 See also <https://help.twitter.com/en/using-twitter/direct-messages>.

27 *1(d) representing, on a home screen displayed on the display, a new message*  
 28 *indicator when the new message flag is set;* –

1  
2  
3  
4  
5  
6  
7  
8  
9  
10  
11  
12  
13  
14  
15  
16  
17  
18  
19  
20  
21  
22  
23  
24  
25  
26  
27  
28

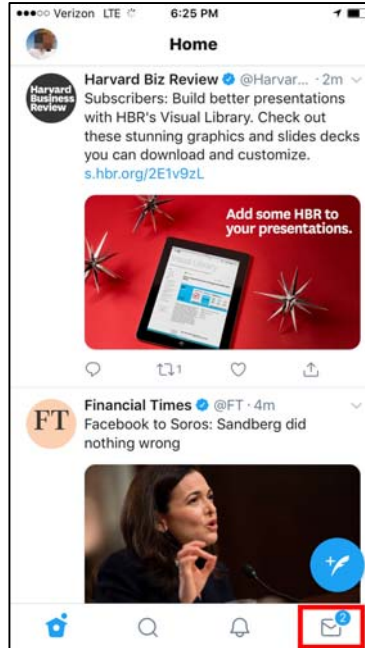

*1(e) receiving an invocation to switch the home screen displayed on the display to a message inventory display screen for viewing a listing including a plurality of electronic messages including the new electronic message, the message inventory display screen displaying a preview, for each listed electronic message, of either a subject line or of a portion of contents of the electronic message, the contents of an electronic message being accessible upon receipt of a request to open an electronic message from the list of messages; –*

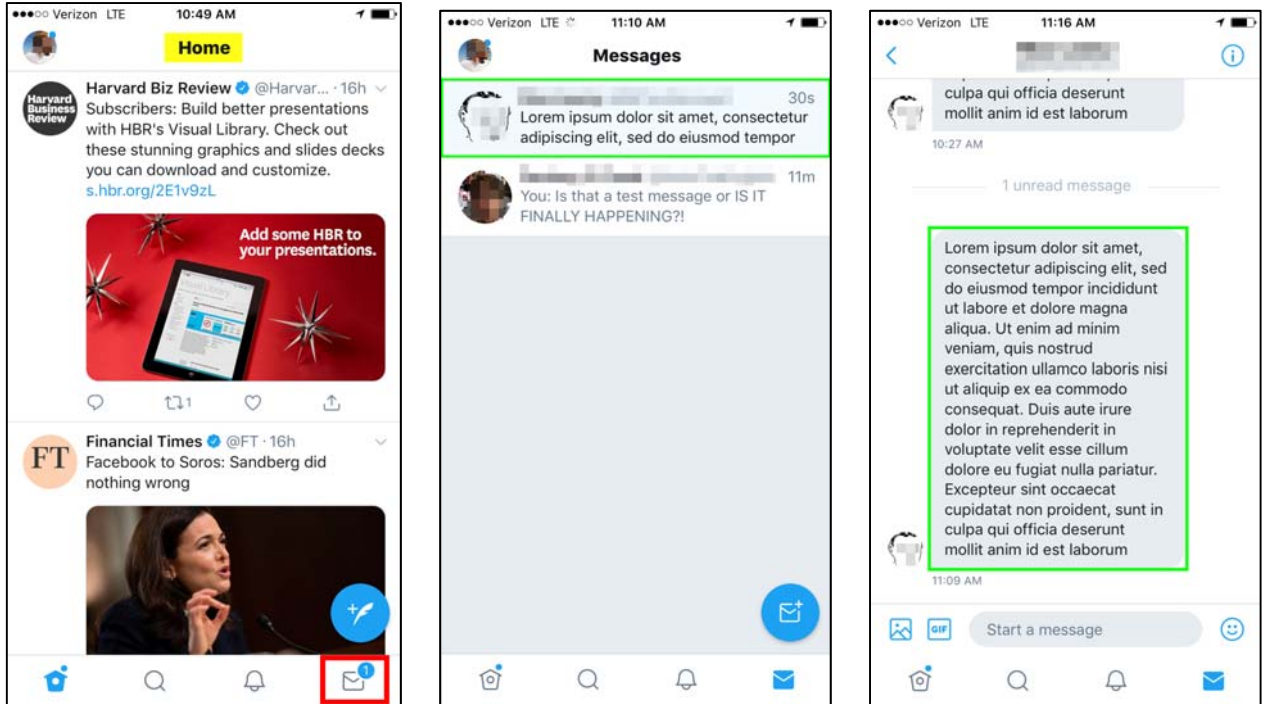

13 *I(f) unsetting the new message flag in response to the invocation to switch the*  
14 *home screen displayed on the display to the message inventory display screen, the*  
15 *unsetting of the flag occurring without having received a request to open the new*  
16 *electronic message; and – On information and belief, the Twitter application unsets*  
17 *the new message flag in response to switching from the home screen to the message*  
18 *inventory display screen, even before there is a request to open a new direct*  
19 *message.*

1  
2  
3  
4  
5  
6  
7  
8  
9  
10  
11  
12  
13  
14  
15  
16  
17  
18  
19  
20  
21  
22  
23  
24  
25  
26  
27  
28

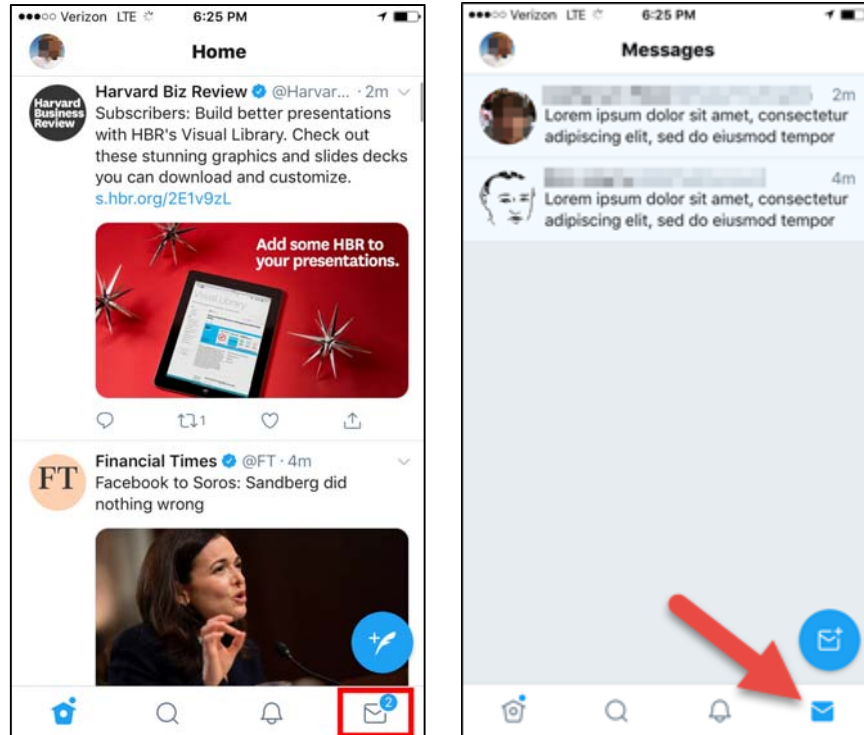

*I(g) receiving an invocation to switch the message inventory display screen to the home screen, wherein the new message indicator represented on the home screen is not displayed as a result of the unsetting of the new message flag. – On information and belief, the Twitter application will not display the new message indicator, as a result of the unsetting of the new message flag, upon returning to the home screen.*

1  
2  
3  
4  
5  
6  
7  
8  
9  
10  
11  
12

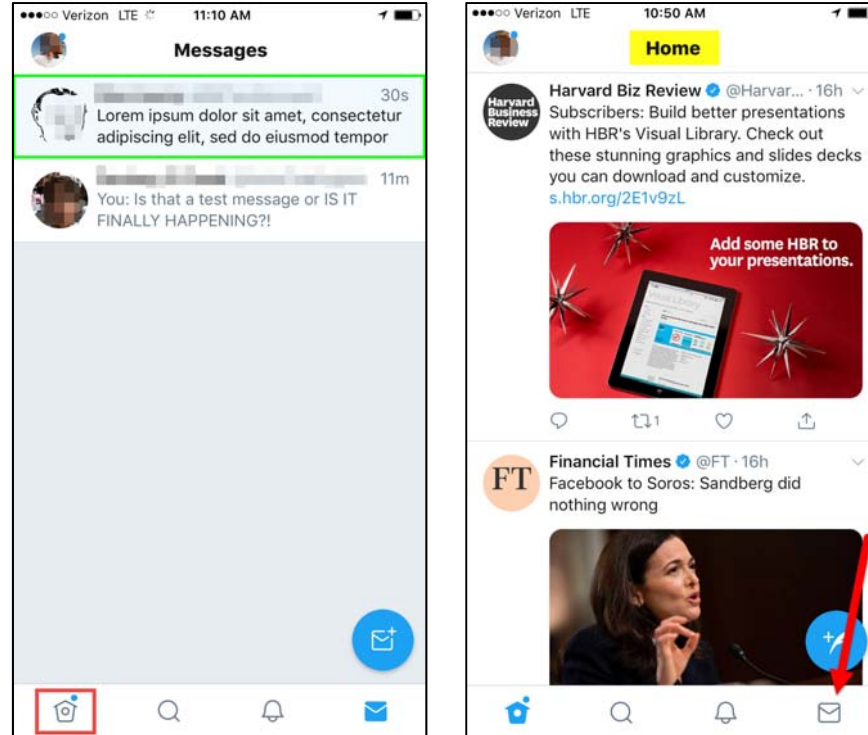

13 165. Additionally, Defendant will be an active inducer of infringement of  
 14 the '089 Patent under 35 U.S.C. § 271(b) and a contributory infringer of the '089  
 15 Patent under 35 U.S.C. § 271(c) should Defendant continue its infringing acts after  
 16 the filing of BlackBerry's original Complaint in this action.

17 166. Defendant knew of the '089 Patent, or should have known of the '089  
 18 Patent but was willfully blind to its existence. Upon information and belief,  
 19 Defendant has had actual knowledge of the '089 Patent since at least as early as the  
 20 filing and/or service of BlackBerry's original Complaint in this action.

21 167. Defendant has provided the '089 Accused Products to its customers  
 22 and, on information and belief, instructions to use the '089 Accused Products in an  
 23 infringing manner at least as early as the filing of BlackBerry's original Complaint  
 24 in this action, while being on notice of or willfully blind to the '089 Patent and  
 25 Defendant's infringement, and knowingly and intentionally encourages and aids its  
 26 customers to directly infringe the '089 Patent.

27 168. Upon information and belief, Defendant provides the '089 Accused  
 28 Products to customers through various third-party application stores (e.g., the Apple

1 App Store) and instructions to end-user customers so that such customers will use  
2 the '089 Accused Products in an infringing manner. For example, Defendant  
3 provides instructions to end-user customers on how to set up, configure, and use  
4 various features of the '089 Accused Products, including Direct Messages.<sup>9</sup>

5 169. Defendant's end-user customers directly infringe at least claim 1 of the  
6 '089 Patent by using the '089 Accused Products in its intended manner to infringe.  
7 Defendant induces such infringement by providing the '089 Accused Products and  
8 instructions to enable and facilitate infringement, knowing of, or being willfully  
9 blind to the existence of, the '089 Patent. Upon information and belief, Defendant  
10 specifically intends that its actions will result in infringement of at least claim 1 of  
11 the '089 Patent, or subjectively believes that its actions will result in infringement of  
12 the '089 Patent but took deliberate actions to avoid learning of those facts, as set  
13 forth above.

14 170. Additionally, Defendant contributorily infringes at least claim 1 of the  
15 '089 Patent by providing the '089 Accused Products and/or software components  
16 thereof, that embody a material part of the claimed inventions of the '089 Patent,  
17 that are known by Defendant to be specially made or adapted for use in an  
18 infringing manner, and are not staple articles with substantial non-infringing uses.  
19 The '089 Accused Products are specially designed to infringe at least claim 1 of the  
20 '089 Patent, and its accused components have no substantial non-infringing uses. In  
21 particular, on information and belief, the software modules and code that implement  
22 and perform the infringing functionalities identified above are specially made and  
23 adapted to carry out said functionality and do not have any substantial non-  
24 infringing uses.

25 171. BlackBerry has been damaged by Defendant's infringement of the '089  
26 Patent and will continue to be damaged unless Defendant is enjoined by this Court.

27 \_\_\_\_\_  
28 <sup>9</sup> See, e.g., <https://help.twitter.com/en/using-twitter/direct-messages>.

1 BlackBerry has suffered and continues to suffer irreparable injury for which there is  
2 no adequate remedy at law. The balance of hardships favors BlackBerry, and public  
3 interest is not disserved by an injunction.

4 172. BlackBerry is entitled to recover from Defendant all damages that  
5 BlackBerry has sustained as a result of Defendant's infringement of the '089 Patent,  
6 including without limitation lost profits and not less than a reasonable royalty.

7 **COUNT VI: INFRINGEMENT OF U.S. PATENT NO. 8,572,182**

8 173. BlackBerry incorporates by reference and re-alleges all of the foregoing  
9 paragraphs of this First Amended Complaint as if fully set forth herein.

10 **The '182 Patent**

11 174. The '182 Patent discloses, among other things, that “[r]educing the  
12 communications in an IM conversation between two devices may be accomplished  
13 by confirming two or more IM events of the conversation at the first device by  
14 sending to the second device a single IM communication that confirms the most  
15 recent of the events,” and that “[i]n some cases, an earlier event can be inferred from  
16 the single IM communication.” '182 Patent at 2:12-28.

17 175. The '182 Patent explains that in various embodiments, “[t]he second  
18 device, upon receipt from the first device of a Message\_Delivered notification for a  
19 particular IM, may infer that all previous instant messages in the conversation that  
20 were sent by the second device to the first device have also been received by the  
21 first device.” *Id.* at 2:55-59. In other words, once the first device indicates it has  
22 received the last-sent message, the second device can infer that it must have also  
23 received one or more messages sent prior to the last-sent message. *Id.* at 2:59-65.

24 176. In a similar manner, the '182 Patent describes that “the second device,  
25 upon receipt from the first device of a Message\_Read notification for a particular  
26 IM, may infer that all previous instant messages in the conversation that were sent  
27 by the second device to the first device have also been received by the first device  
28 and read by the user of the first device.” *Id.* at 2:65-3:3. In other words, once the



1 first device indicates it has received the last-sent message and it has been read by the  
 2 user of the first device, the second device can infer that the user of the first device  
 3 must also have read one or more messages sent prior to the last-sent message. *Id.* at  
 4 2:65-3:10.

5 177. Figure 1 of the '182 Patent illustrates multiple devices 102, 104, and  
 6 106, each with respective IM clients 140 that may include an event handler 141. *Id.*  
 7 at 4:25-28. The '182 Patent explains that “[w]hen the user of device 102 sends an  
 8 instant message to the user of device 104, the instant message is handled by IM  
 9 client 140 on device 102, communicated to network 120, communicated to a relay  
 10 computer or computers 150, and passed back to network 120 for communication to  
 11 device 104. When the user of device 106 sends an instant message to the user of  
 12 device 104, the instant message is handled by IM client 140 on device 106,  
 13 communicated to network 130, communicated to relay computer(s) 150, and passed  
 14 to network 120 for communication to device 104.” *Id.* at 4:28-38.

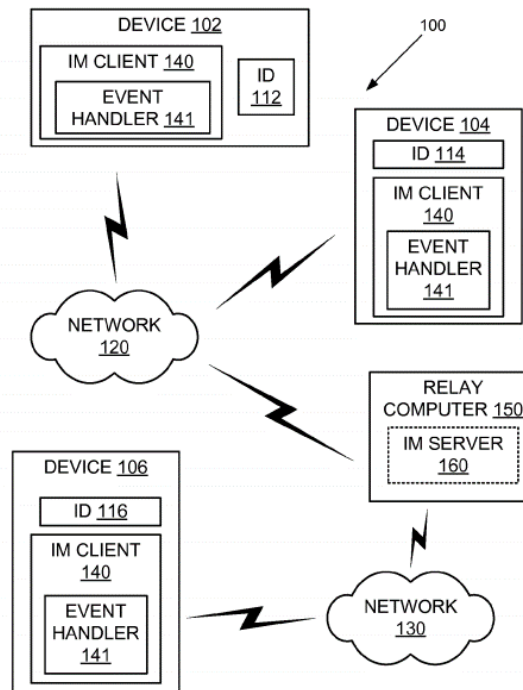
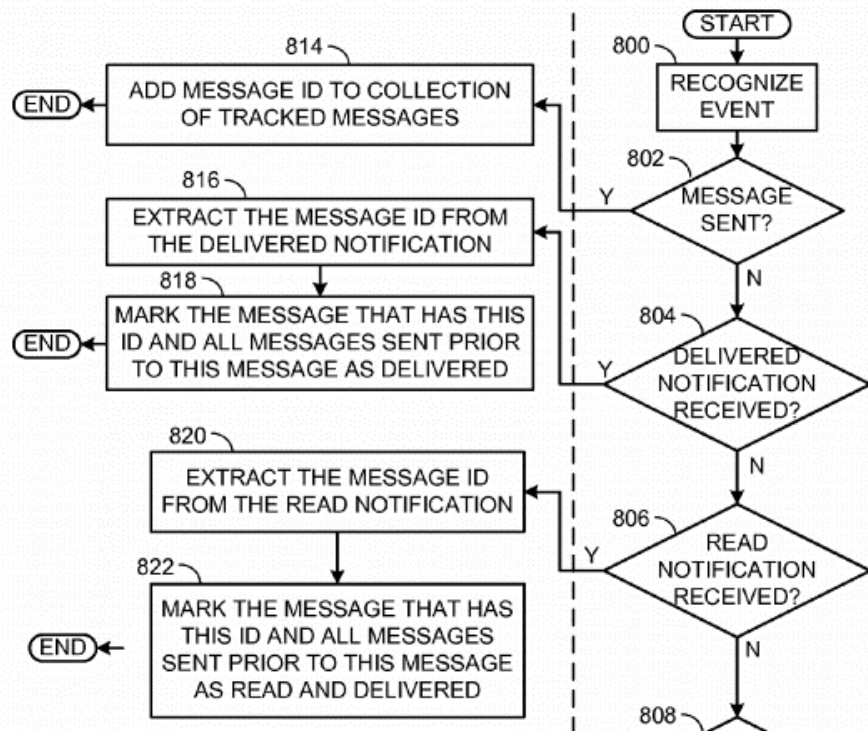

FIG. 1

15  
16  
17  
18  
19  
20  
21  
22  
23  
24  
25  
26  
27 *Id.* at Fig. 1.

28

1 178. Figure 8 depicts an exemplary method implemented by IM client 140  
 2 on a communication device sending one or more IM messages according to various  
 3 embodiments. '182 Patent at 6:57-60. At step 800, IM client 140 determines that an  
 4 event has occurred at device 104. *Id.* at 6:61-62. The '182 Patent explains that  
 5 “[t]he recognized event may be sending a message, receiving a Message\_Delivered  
 6 notification, receiving a Message\_Read notification, receiving a Typing\_Started  
 7 notification, receiving a Typing\_Stopped notification, or receiving an instant  
 8 message, as shown at 802, 804, 806, 808, 810 and 812, respectively.” *Id.* at 6:62-67.  
 9 When a Message\_Read notification is recognized (step 806), the IM client 140  
 10 extracts the ID number of a message embedded in the Message\_Read notification  
 11 (step 820). *Id.* at 7:16-20. The '182 Patent describes that in step 822, IM client 140  
 12 compares the extracted ID number to the collection of tracked messages, and marks  
 13 the message that has this ID number as read and delivered. IM client 140 marks also  
 14 messages of that conversation that were sent prior to the newly marked message as  
 15 read and delivered.” *Id.* at 7:20-25.



16  
17  
18  
19  
20  
21  
22  
23  
24  
25  
26  
27  
28 *Id.* at Fig. 8.

1           179. The '182 Patent thus describes, among other things, “[a] method in a  
2 first communication device for reducing communications in an instant messaging  
3 conversation between said first device and a second communication device, the  
4 method comprising: sending to said second device, a plurality of instant messages of  
5 said conversation; receiving from said second device, after sending said plurality of  
6 instant messages, at least a notification of the status of only a particular one of said  
7 plurality of instant messages sent by said first device to said second device without  
8 having previously received a notification of the status of any of said plurality of  
9 instant messages sent prior to said particular one of said plurality of instant  
10 messages; and in response to receipt of said notification, a processor updating an  
11 internal record to reflect said status for said particular one of said plurality of instant  
12 messages and to reflect an inferred status for all of said plurality of instant messages  
13 of said conversation sent prior to said particular one of said plurality of instant  
14 messages.” *Id.* at claim 1.

15                           **The Inventions Claimed in the '182 Patent Were Not**  
16                           **Well-Understood, Routine, or Conventional**

17           180. A method or system for sending a plurality of instant messages,  
18 subsequently receiving at least a notification of the status of only a particular one of  
19 said plurality of instant messages, and in response to receiving the notification,  
20 updating an internal record to reflect an inferred status for all of said plurality of  
21 instant messages sent prior to said particular one instant message, was not common  
22 or conventional at the time of the '182 Patent.

23           181. The inventor of the '182 Patent recognized issues with IM messaging  
24 communications and the need for more efficient communication of read receipts  
25 between IM clients. For example, the inventor noted that “[s]ome IM systems use  
26 notifications to provide users with ‘clues’ about the status of a conversation. For  
27 example, a Message\_Delivered notification may be used to notify a sender of a  
28 message that the message was received by the target communication device. In

1 another example, a Message\_Read notification may be used to notify a sender of a  
2 message that the message was read by a user of the target communication device. In  
3 yet another example, Typing\_Started and Typing\_Stopped messages may be used to  
4 notify a sender of a message when a user of the target communication device is  
5 typing a response to the message.” *Id.* at 1:22-32. As recognized by the inventor of  
6 the ’182 patent, these “[n]otifications sent in an IM system occupy bandwidth that  
7 would otherwise be available for other communications.” *Id.* at 33-34.

8         182. Given the state of the art at the time of the invention of the ’182 Patent,  
9 the inventive concepts of the ’182 Patent were not conventional, well-understood, or  
10 routine. The ’182 Patent discloses, among other things, an unconventional  
11 technological solution to an issue arising specifically in the context of electronic  
12 communications systems and electronic messaging received within those  
13 communications systems. The solution implemented by the ’182 Patent provides a  
14 specific and substantial improvement over prior messaging notification systems  
15 resulting in more efficient use of system bandwidth, including by introducing novel  
16 elements directed to improving the function and working of communications  
17 systems such as, among other things, the claimed “receiving . . . at least a  
18 notification of the status of only a particular one of said plurality of instant messages  
19 sent . . .” and “a processor updating an internal record to reflect said status for said  
20 particular one of said plurality of instant messages and to reflect an inferred status  
21 for all of said plurality of instant messages of said conversation sent prior to said  
22 particular one of said plurality of instant messages” (claim 1; substantially similar  
23 limitations in claims 4 and 5).

24         183. Consistent with the problem addressed being rooted in electronic  
25 messaging between wireless communications devices, the ’182 Patent’s solutions  
26 naturally are also rooted in the same technology that cannot be performed with pen  
27 and paper or in the human mind.

28

1 184. This technical context is reflected in the '182 Patent's claims. For  
2 example, various claims of the '182 Patent require transmissions between  
3 communication devices, sending and receiving instant messages, electronic  
4 notifications, and a processor updating an internal record.

5 185. A person having ordinary skill in the art at the time of the inventions of  
6 the '182 Patent would not have understood that the inventions could or would be  
7 performed solely in the human mind or using pen and paper. Using pen and paper  
8 would ignore the stated purpose of the '182 Patent and the problem it was  
9 specifically designed to address. Doing so would also run counter to the inventors'  
10 detailed description of the inventions and the language of the claims and be a  
11 practical impossibility.

#### 12 **'182 Patent Allegations**

13 186. Defendant has infringed and is infringing, either literally or under the  
14 doctrine of equivalents, the '182 Patent in violation of 35 U.S.C. § 271 *et seq.*,  
15 directly and/or indirectly, by making, using, selling, offering for sale, and/or  
16 importing into the United States without authority or license, the Twitter application  
17 (hereinafter "the '182 Accused Products") that infringe at least claims 1 and 4 of the  
18 '182 Patent.

19 187. On information and belief after reasonable investigation, the '182  
20 Accused Products contain messaging functionality designed and used to send and  
21 receive efficient read receipts based on updating an internal record to reflect an  
22 inferred status of instant messages in a manner that infringes the '182 Patent.

23 188. As just one non-limiting example, set forth below (with claim language  
24 in italics) is a description of infringement of exemplary claim 1 of the '182 Patent in  
25 connection with the Twitter application. This description is based on publicly  
26 available information. BlackBerry reserves the right to modify this description,  
27 including, for example, on the basis of information about the '182 Accused Products  
28 that it obtains during discovery.

1            *I(a) A method in a first communication device for reducing communications*  
 2 *in an instant messaging conversation between said first device and a second*  
 3 *communication device, the method comprising:* – Defendant makes and uses the  
 4 Twitter application which is executed on a communications device such as a mobile  
 5 phone or computer, for example. Regardless of whether the preamble of claim 1  
 6 adds any substantive limitation to the claim, the claim language is met by the '182  
 7 Accused Products, as the '182 Accused Products include a method for reducing  
 8 communications in an instant messaging conversation between a first  
 9 communication device and a second communication device as further described  
 10 below for the remaining claim limitations, as described below.

11            *I(b) sending to said second device, a plurality of instant messages of said*  
 12 *conversation;* – For example, users of the Twitter application send to one another a  
 13 plurality of instant messages as part of an instant messaging conversation, such as a  
 14 conversation between a first device and a second device:

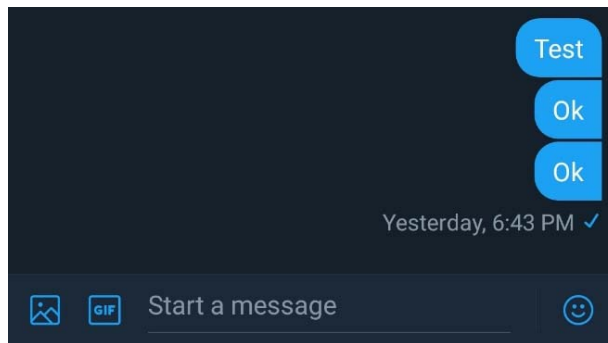

21            *I(c) receiving from said second device, after sending said plurality of instant*  
 22 *messages, at least a notification of the status of only a particular one of said*  
 23 *plurality of instant messages sent by said first device to said second device without*  
 24 *having previously received a notification of the status of any of said plurality of*  
 25 *instant messages sent prior to said particular one of said plurality of instant*  
 26 *messages; and* – For example, on information and belief, after a first device sends a  
 27 plurality of instant messages, it receives a notification of the status of only a  
 28 particular one of said plurality of instant messages without having previously

1 received a notification of the status of any messages sent prior to the particular  
2 message for which a notification was received:

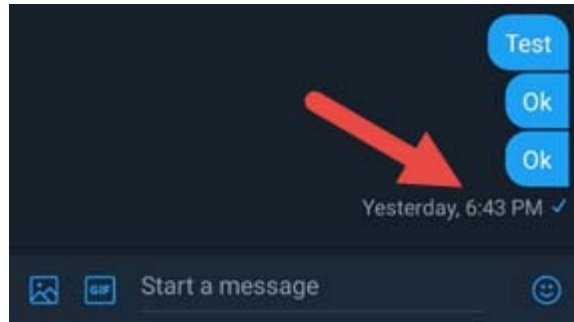

8 (indicating via the blue checkmark that the message has been seen by the recipient)

9 *I(d) in response to receipt of said notification, a processor updating an*  
10 *internal record to reflect said status for said particular one of said plurality of*  
11 *instant messages and to reflect an inferred status for all of said plurality of instant*  
12 *messages of said conversation sent prior to said particular one of said plurality of*  
13 *instant messages. – For example, on information and belief, in response to receipt of*  
14 *the notification, a processor in the first device updates an internal record to reflect*  
15 *the status of the particular message and to reflect an inferred status for prior ones of*  
16 *the plurality of messages:*

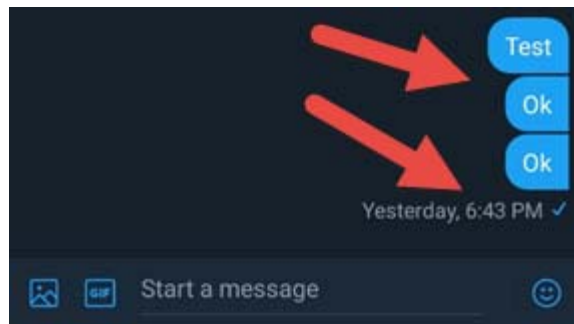

23 (indicating via the blue checkmark that the message has been seen by the recipient);  
24 See also [https://developer.twitter.com/en/docs/direct-messages/typing-indicator-and-](https://developer.twitter.com/en/docs/direct-messages/typing-indicator-and-read-receipts/api-reference/new-read-receipt)  
25 [read-receipts/api-reference/new-read-receipt](https://developer.twitter.com/en/docs/direct-messages/typing-indicator-and-read-receipts/api-reference/new-read-receipt) (defining the “required” parameter  
26 last\_read\_event\_id, which is “[t]he message ID of the most recent message to be  
27 marked read. All messages before it will be marked read as well.”).

28

1           189. Additionally, Defendant has been, and currently is, an active inducer of  
2 infringement of the '182 Patent under 35 U.S.C. § 271(b) and contributory  
3 infringers of the '182 Patent under 35 U.S.C. § 271(c).

4           190. BlackBerry made Defendant aware of the '182 Patent and its  
5 infringement thereof by letter dated June 7, 2017. Ex. I. Accordingly, Defendant  
6 has had actual knowledge of (or was willfully blind to the existence of) the '182  
7 Patent and its infringement thereof at least as of June 7, 2017, but has failed to take  
8 any action to avoid infringement. Indeed, on information and belief, Defendant has  
9 released over two dozen new versions of the iOS Twitter application since being put  
10 on notice of its infringement—none of which removed the infringing functionality.  
11 (*See, e.g.*, <https://itunes.apple.com/in/app/twitter/id333903271?mt=8> (link to version  
12 history contained therein). Accordingly, Defendant knew that it infringed the '182  
13 Patent well before BlackBerry filed this action and, despite its knowledge, acted  
14 egregiously and willfully by continuing to infringe the '182 Patent.

15           191. Defendant has provided the '182 Accused Products to its customers  
16 and, on information and belief, instructions to use the '182 Accused Products in an  
17 infringing manner while being on notice of or willfully blind to the '182 Patent and  
18 Defendant's infringement, and knowingly and intentionally encourages and aids its  
19 customers to directly infringe the '182 Patent.

20           192. Upon information and belief, Defendant provides the '182 Accused  
21 Products to customers through various third-party application stores (*e.g.*, the Apple  
22 App Store) and instructions to end-user customers so that such customers will use  
23 the '182 Accused Products in an infringing manner. For example, Defendant  
24 provides instructions to end-user customers on how to set up, configure, and use  
25 various features of the '182 Accused Products, as well as how to send messages and  
26  
27  
28



1 disable/enable read receipts associated with Twitter Direct Messaging  
2 conversations.<sup>10</sup>

3 193. Defendant's end-user customers directly infringe at least claims 1 and 4  
4 of the '182 Patent by using the '182 Accused Products in their intended manner to  
5 infringe. Defendant induces such infringement by providing the '182 Accused  
6 Products and instructions to enable and facilitate infringement, knowing of, or being  
7 willfully blind to the existence of, the '182 Patent. Upon information and belief,  
8 Defendant specifically intends that its actions will result in infringement of at least  
9 claims 1 and 4 of the '182 Patent, or subjectively believe that its actions will result  
10 in infringement of the '182 Patent but took deliberate actions to avoid learning of  
11 those facts, as set forth above.

12 194. Additionally, Defendant contributorily infringes at least claims 1 and 4  
13 of the '182 Patent by providing the '182 Accused Products and/or software  
14 components thereof, that embody a material part of the claimed inventions of the  
15 '182 Patent, that are known by Defendant to be specially made or adapted for use in  
16 an infringing manner, and are not staple articles with substantial non-infringing  
17 uses. The '182 Accused Products are specially designed to infringe at least claims 1  
18 and 4 of the '182 Patent, and their accused components have no substantial non-  
19 infringing uses. In particular, on information and belief, the software modules and  
20 code that implement and perform the infringing functionalities identified above are  
21 specially made and adapted to carry out said functionality and do not have any  
22 substantial non-infringing uses.

23 195. Defendant's infringement of the '182 Patent was and continues to be  
24 willful and deliberate, entitling BlackBerry to enhanced damages and attorneys'  
25 fees.

26  
27  
28 <sup>10</sup> See, e.g., <https://help.twitter.com/en/using-twitter/direct-messages>.

1 196. Additional discovery regarding Defendant’s knowledge of the ’182  
2 Patent likely will uncover additional facts related to Defendant’s willful  
3 infringement.

4 197. Defendant’s infringement of the ’182 Patent is exceptional and entitles  
5 BlackBerry to attorneys’ fees and costs incurred in prosecuting this action under 35  
6 U.S.C. § 285.

7 198. BlackBerry has been damaged by Defendant’s infringement of the ’182  
8 Patent and will continue to be damaged unless Defendant is enjoined by this Court.  
9 BlackBerry has suffered and continues to suffer irreparable injury for which there is  
10 no adequate remedy at law. The balance of hardships favors BlackBerry, and public  
11 interest is not disserved by an injunction.

12 199. BlackBerry is entitled to recover from Defendant all damages that  
13 BlackBerry has sustained as a result of Defendant’s infringement of the ’182 Patent,  
14 including without limitation lost profits and not less than a reasonable royalty.

15 **COUNT VII: INFRINGEMENT OF U.S. PATENT NO. 8,825,777**

16 200. BlackBerry incorporates by reference and re-alleges all of the foregoing  
17 paragraphs of this First Amended Complaint as if fully set forth herein.

18 **The ’777 Patent**

19 201. The ’777 Patent discloses, among other things, “a way to regulate  
20 electronic communications within a social group of a social network by determining  
21 if one or more new messages to be communicated to the social group has content  
22 that is substantially similar to a multiplicity of messages recently intended for  
23 communication to the social group, and then delaying notification of the one or  
24 more new messages to a member of the social group if the content is found to be  
25 objectionable. Also provided herein is a way to observe messages, discover  
26 detrimental patterns to users or to network traffic, and make adjustments to the  
27 speed of such messages so that the detrimental patterns may be mitigated.” ’777  
28 Patent at 2:32-42. For example, certain aspects of the ’777 Patent “provide[] for

1 selective delivery of social network messages within a social network. When it is  
2 determined that one or more new messages to be communicated to members of a  
3 social group of the social network have content substantially similar to a given  
4 content of a plurality of messages previously communicated to the social group,  
5 notification of the one or more new messages to the one or more members of the  
6 social group can be selectively adjusted.” *Id.* at Abstract.

7         202. The ’777 Patent explains that “[t]he relative ease and speed with which  
8 content can be generated and communicated within social networks” has downsides,  
9 including, for example, that “[h]ackers, or even normal users, can de-frame or bully  
10 other users in a social network environment very easily and quickly with messages  
11 whose content may include misinformation or untruthful, derogatory or defamatory  
12 statements that may even have elements of libel or slander.” *Id.* at 1:27-34. The  
13 ’777 Patent further explains that “the unrestrained dissemination of messages in a  
14 social network can have adverse effects on network traffic. When sensational  
15 messages are posted and quickly re-posted to large numbers of members or users of  
16 a social network, a condition referred to as the ‘circular mill’ phenomenon can arise.  
17 The term ‘circular mill’ in the field of sociology refers to a situation in which ants  
18 that lose the pheromone track of other ants simply continue to follow one another,  
19 forming a continuously rotating circle or spiral and eventually dying from  
20 exhaustion. With the ability of social network users to easily and in real-time copy  
21 and re-transmit popular messages from one user to a multitude of other users, as is  
22 the case of re-tweeting on Twitter, for example, the potential reach of such re-  
23 postings within the social group or network can be exponential, presenting a  
24 significant hazard to bandwidth and other traffic resources of the network.” *Id.* at  
25 1:42-58.

26         203. Accordingly, the ’777 Patent explains that one or more processors in  
27 the social network “can monitor messages communicated within the social group  
28 and determine messages sharing given content that has been communicated to the

1 social group.” *Id.* at 5:38-41. The ’777 Patent further explains that the sharing of  
2 messages within the social group “may occur, for example, where at least a growth  
3 rate of distribution of the messages sharing the given content meets or exceeds a  
4 growth rate threshold, or where a quantity of the plurality of messages sharing the  
5 given content meets or exceeds a message quantity threshold.” *Id.* at 5:42-46.  
6 Therefore, as taught by the ’777 Patent, “[i]f it is determined that the content of the  
7 one or more new messages to be communicated has content substantially similar to  
8 the content of the stored messages, notification of the one or more new messages to  
9 one or more members of the social group can be selectively delayed [which] is of  
10 use where defamatory content or misinformation contained in previously  
11 communicated messages has been identified. Selectively delaying notification of the  
12 one or more new messages with the same undesirable content provides the benefit of  
13 slowing the spread of cyber-bullying messages within a social group, for example.  
14 The given content of the previously communicated messages may be content related  
15 to an objectionable topic or content related to a member of the social group.” *Id.* at  
16 5:54-67. The invention of the ’777 Patent therefore avoids the undesirable  
17 proliferation of specified content and the traffic load and bandwidth strains  
18 associated therewith.

19       204. Figure 4, for example, illustrates representative operations by which the  
20 patent selectively adjusts notifications. “At Block **410**, the distribution of messages  
21 within a social group of a social network is observed. From that observation, a given  
22 content shared by previously communicated messages to the social group can be  
23 determined, at Block **420**. One or more detrimental patterns of the observed  
24 messages that share the given content can be determined, at Block **430**. The  
25 detrimental patterns can be potentially socially harmful to either or both of a user of  
26 the social network or to message traffic in the social network. At Block **440**, in  
27 response to the discovery of the detrimental patterns, notification of one or more  
28 new messages having content substantially similar to the given content shared by the

1 previously communicated messages can be selectively adjusted in order to mitigate  
 2 the one or more detrimental patterns.” *Id.* at 10:61-11:15.

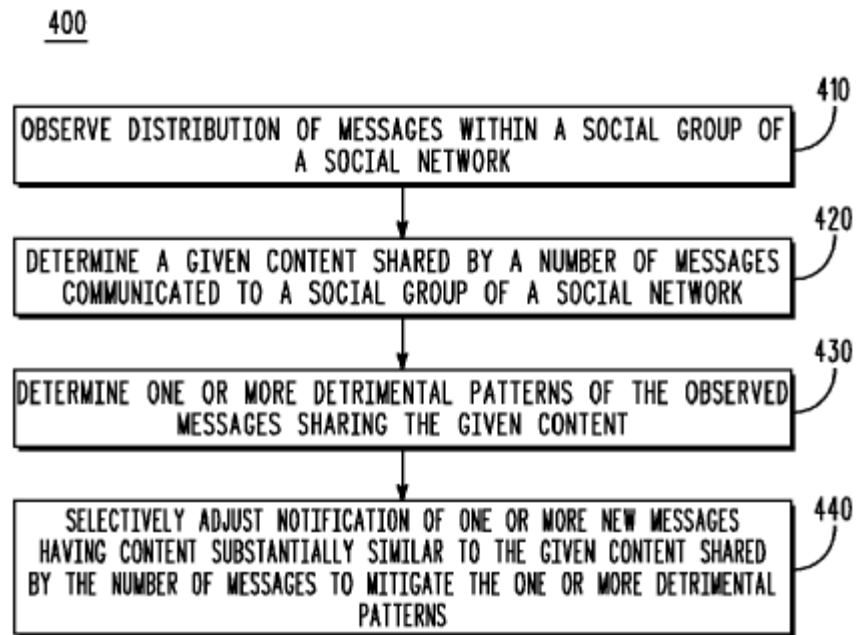

14 **FIG. 4**

15 *Id.* at Fig. 4.

17 205. The '777 Patent thus describes, among other things, “[a] method of  
 18 managing electronic communications within a social group of a social network,  
 19 comprising: monitoring messages communicated within the social group;  
 20 determining content shared by a number of messages communicated within the  
 21 social group, wherein the number of messages sharing the determined content  
 22 satisfies at least one of: a growth rate of the number of messages meets or exceeds a  
 23 growth rate threshold; and the number of messages meets or exceeds a message  
 24 quantity threshold; determining whether one or more new messages to be  
 25 communicated to one or more members of the social group comprises content  
 26 similar to the determined content; and selectively adjusting notification of the one or  
 27 more new messages to the one or more members of the social group in response to  
 28 determining that the one or more new messages to be communicated to the one or

1 more members of the social group comprises content similar to the determined  
2 content” *Id.* at claim 1.

3 **The Inventions Claimed in the ’777 Patent Were Not**  
4 **Well-Understood, Routine, or Conventional**

5 206. The method of managing electronic communications within a social  
6 network by monitoring messages within the social network, determining content  
7 shared by a number of messages that exceeds a threshold, and then determining  
8 whether one or more new messages to be communicated to members in the social  
9 network comprises content similar to the determined content (which may be  
10 undesirable content, such as misinformation, slander, libel, or the like) so that  
11 notification of those messages may be selectively adjusted by the social network  
12 was not common or conventional at the time of the ’777 Patent.

13 207. The inventors of the ’777 Patent recognized that “[t]he relative ease and  
14 speed with which content can be generated and communicated within social  
15 networks” has resulted in the proliferation of undesirable content, such as content  
16 that includes “misinformation or untruthful, derogatory or defamatory statements  
17 that may have elements of libel or slander.” ’777 Patent at 1:27-34. It is  
18 specifically the technological environment in which social networks are  
19 implemented and exist that allows for this proliferation of content such that “the rate  
20 of transmission and re-transmission of detrimental messages can grow at such a fast  
21 rate as to render counter-point or corrective communications ineffective, resulting in  
22 potentially irrevocable damage to the target of the misinformation.” *Id.* at 1:35-42.  
23 Such issues do not exist “in a normal free-speech arena” in a non-technological  
24 context. *Id.*

25 208. The inventors recognized that by identifying such messages and  
26 selectively adjusting notification of such messages within the social network, the  
27 proliferation of misinformation and other undesirable content could be controlled.  
28 The inventors further recognized that by avoiding said proliferation and phenomena

1 such as the “circular mill,” the inventions of the ’777 Patent would preserve network  
2 bandwidth and traffic resources, resulting in an improved communications system,  
3 while not censoring users of the social network.

4         209. Given the state of the art at the time of the invention of the ’777 Patent,  
5 the inventive concepts of the ’777 Patent were not conventional, well-understood, or  
6 routine. The ’777 Patent discloses, among other things, an unconventional  
7 technological solution to an issue arising specifically in the context of electronic  
8 communications systems and social network servers. The solution implemented by  
9 the ’777 Patent provides a specific and substantial improvement over prior social  
10 networks and systems resulting in more efficient use of system bandwidth, including  
11 by introducing novel elements directed to improving the function and working of  
12 communications systems such as, among other things, the claimed “social network  
13 server coupled to a communications network that facilitates exchange of electronic  
14 communications within a social group of the communications network” and that  
15 comprises a process and memory configured to implement the claimed selectively  
16 adjusting notification method (claim 10).

17         210. Consistent with the problem addressed being rooted in electronic  
18 messaging between communications devices in a social network, the ’777 Patent’s  
19 solutions naturally are also rooted in the same technology that cannot be performed  
20 with pen and paper or in the human mind.

21         211. This technical context is reflected in the ’777 Patent’s claims. For  
22 example, various claims of the ’777 Patent require electronic communications in a  
23 social network, monitoring electronic messages in the social network, determining  
24 similarity between the electronic messages, and selectively adjusting notifications  
25 within the social network.

26         212. A person having ordinary skill in the art at the time of the inventions of  
27 the ’777 Patent would not have understood that the inventions could or would be  
28 performed solely in the human mind or using pen and paper. Using pen and paper

1 would ignore the stated purpose of the '777 Patent and the problem it was  
2 specifically designed to address. Doing so would also run counter to the inventors'  
3 detailed description of the inventions and the language of the claims and be a  
4 practical impossibility.

5 **'777 Patent Allegations**

6 213. Defendant has infringed and is infringing, either literally or under the  
7 doctrine of equivalents, the '777 Patent in violation of 35 U.S.C. § 271 *et seq.*,  
8 directly and/or indirectly, by making, using, selling, offering for sale, and/or  
9 importing into the United States without authority or license, the Twitter platform  
10 and application, and their associated backend servers and systems (hereinafter "the  
11 '777 Accused Products") that infringe at least claims 1, 10, and 19 of the '777  
12 Patent.

13 214. On information and belief after reasonable investigation, the '777  
14 Accused Products contain Tweet filtering functionality designed and used to filter  
15 low quality Tweets by selectively adjusting notification of such Tweets in a manner  
16 that infringes the '777 Patent.

17 215. As just one non-limiting example, set forth below (with claim language  
18 in italics) is a description of infringement of exemplary claim 1 of the '777 Patent in  
19 connection with the Twitter platform. This description is based on publicly  
20 available information. BlackBerry reserves the right to modify this description,  
21 including, for example, on the basis of information about the '777 Accused Products  
22 that it obtains during discovery.

23 *1(a) A method of managing electronic communications within a social group*  
24 *of a social network, comprising:* – Defendant makes and uses the Twitter platform  
25 and application which comprise a social network that includes social groups, such as  
26 a user's group of followers or friends for example. Regardless of whether the  
27 preamble of claim 1 adds any substantive limitation to the claim, the claim language  
28 is met by the '777 Accused Products, as the '777 Accused Products include a



1 method of managing communications within a social group of the network as further  
2 described below.

## 3 **How to Tweet**

4  
5 A Tweet may contain photos, GIFs, videos, links, and text.

6 View instructions for:



### 8 **How to Tweet**

- 9
- 10 1. Type your Tweet into the **compose box** at the top of your  
11 Home timeline, or click the **Tweet** button in the top  
12 navigation bar.
  - 13 2. You can include up to 4 photos, a GIF, or a video in your  
14 Tweet.
  - 15 3. Click the **Tweet** button to post the Tweet to your profile.

16 <https://help.twitter.com/en/using-twitter/how-to-tweet>

### 17 **Why doesn't all content show up in Twitter search?**

18 In order to keep your search results relevant, Twitter filters search results for quality Tweets and accounts.  
19 Material that jeopardizes search quality or creates a bad search experience for other people may be  
20 automatically removed from Twitter search. Read more about this here, [https://help.twitter.com/using-  
twitter/twitter-search-not-working](https://help.twitter.com/using-twitter/twitter-search-not-working).

21 General rules for using Twitter search

22 The Twitter Rules, <https://help.twitter.com/en/rules-and-policies/twitter-rules>, explain what behaviors are  
23 permitted on Twitter. In addition to these rules, we've included some tips below to keep your content relevant  
24 (and your Tweets in Twitter search).

25  
26  
27  
28

1  
2  
3  
4  
5  
6  
7  
8  
9  
10  
11  
12  
13  
14  
15  
16  
17  
18  
19  
20  
21  
22  
23  
24  
25  
26  
27  
28

**Please do not:**

- Repeatedly post duplicate or near-duplicate content (links or Tweets).
- Abuse trending topics or hashtags (topic words with a # sign).
- Send automated Tweets or replies.
- Use bots or applications to post similar messages based on keywords.
- Post similar messages over multiple accounts.
- Aggressively follow and unfollow people.

Twitter may automatically remove accounts engaging in these behaviors from search (or even suspend in some cases) in order to ensure the best experience for everyone.

<https://help.twitter.com/en/rules-and-policies/twitter-search-policies>.

*I(b) monitoring messages communicated within the social group;* – For example, Defendant monitors Tweets communicated within the Twitter social network and Tweets between Twitter users and their friends/followers.

### **What is the Notifications timeline?**

- The **Notifications timeline** offers a simple way to see how others on Twitter are interacting with you.
- From the Notifications timeline, you'll be able to see which of your Tweets have been liked, plus the latest Retweets (of your Tweets), Tweets directed to you (replies and mentions) and your new followers.
- You can view your notifications in two ways: **All** shows you notifications for account activity like new followers, Retweets, mentions, and likes. **Mentions** shows you notifications only for Tweets that mention your username.
- In addition to your notifications, we will elevate content that we think you'll be most interested in and contributes to the conversation in a meaningful way, such as content that is relevant, credible, and safe.

<https://help.twitter.com/en/managing-your-account/understanding-the-notifications-timeline>.

For example, Defendant monitors Tweets in order to implement, *inter alia*, a quality and other filters:

1  
2  
3  
4  
5  
6  
7  
8  
9  
10  
11  
12  
13  
14  
15  
16  
17  
18  
19  
20  
21  
22  
23  
24  
25  
26  
27  
28

- **Quality filter**, when turned on, filters lower-quality content from your notifications, for example, duplicate Tweets or content that appears to be automated — it does not filter notifications from people you follow or accounts you’ve recently interacted with. You have the option to turn this on or off in your notifications settings. (Instructions listed below.)

<https://help.twitter.com/en/managing-your-account/understanding-the-notifications-timeline>;

### Rules for participating in contests on Twitter

Businesses sometimes host contests and offer prizes to Retweet an update, following a particular account, or posting Tweets with a specific hashtag topic or reply. If you’re running a contest, check out this [article](#) for guidelines for contests on Twitter.

If you repeatedly post near-duplicate updates or duplicate links in order to enter contests, you may be filtered from search. Please keep in mind that you are responsible for the updates that you post to your Twitter account.

<https://help.twitter.com/en/rules-and-policies/twitter-search-policies>.

*1(c) determining content shared by a number of messages communicated within the social group, wherein the number of messages sharing the determined content satisfies at least one of: a growth rate of the number of messages meets or exceeds a growth rate threshold; and the number of messages meets or exceeds a message quantity threshold;* – For example, on information and belief, Defendant determines content based on monitoring and observing that a number of Tweets have been communicated within a social group (e.g., a group of Twitter users following one or more other Twitter users) that contain content exceeding some threshold. For example, on information and belief, if two Twitter users post a series of Tweets directed to a third Twitter user (e.g., by including a mention of the third Twitter user within their Tweets) exceeding some threshold, Defendant will determine the content shared by those Tweets. See 1(b), above.

1            *1(d) determining whether one or more new messages to be communicated to*  
2 *one or more members of the social group comprises content similar to the*  
3 *determined content; and* – For example, on information and belief, Defendant  
4 determines whether one or more new Tweets within the social group (*e.g.*, the group  
5 of Twitter users following one or more other Twitter users) comprises content  
6 similar to the determined content. For example, on information and belief, if the  
7 two Twitter users who posted a series of Tweets directed to a third Twitter user  
8 (*e.g.*, by including a mention of the third Twitter user within their Tweets) continue  
9 to post additional Tweets directed to the third Twitter user containing similar  
10 content, Defendant will identify those additional Tweets. *See* 1(b) and 1(c), above.

11            *1(e) selectively adjusting notification of the one or more new messages to the*  
12 *one or more members of the social group in response to determining that the one or*  
13 *more new messages to be communicated to the one or more members of the social*  
14 *group comprises content similar to the determined content.* – For example, on  
15 information and belief, Defendant, including through its quality filter, will  
16 selectively adjust notification of Tweets containing determined content. For  
17 example, on information and belief, Defendant will selectively adjust which of the  
18 two Twitter users’ additional Tweets are displayed on the third Twitter user’s  
19 notifications page. For example, Defendant’s quality filter “filters lower-quality  
20 content from your notifications, for example, duplicate Tweets or content that  
21 appears to be automated”:

- 22            • **Quality filter**, when turned on, filters lower-quality content  
23            from your notifications, for example, duplicate Tweets or  
24            content that appears to be automated — it does not filter  
25            notifications from people you follow or accounts you’ve  
26            recently interacted with. You have the option to turn this on or  
27            off in your notifications settings. (Instructions listed below.)

28

1 [https://help.twitter.com/en/managing-your-account/understanding-the-notifications-](https://help.twitter.com/en/managing-your-account/understanding-the-notifications-timeline)  
2 [timeline](https://help.twitter.com/en/managing-your-account/understanding-the-notifications-timeline);

## 3 **About specific instances when a** 4 **Tweet's reach may be limited**

5  
6 People may express themselves on Twitter as long as they do not violate our  
7 [Twitter Rules](#). We do not block, limit, or remove content based on an  
8 individual's views or opinions. In some situations, your Tweet may not be  
9 seen by everyone, as outlined below:

10 . . .

- 11 • [Quality filter](#) — Quality filter is a setting that, when turned on, can  
12 improve the quality of Tweets people see by using a variety of signals,  
13 such as account origin and behavior. Turning it on filters lower-quality  
14 content, like duplicate Tweets or content that appears to be  
15 automated, from your notifications and other parts of your Twitter  
16 experience. Quality filter does not filter content from people you follow  
17 or accounts you've recently interacted with.

18 <https://help.twitter.com/en/rules-and-policies/twitter-reach-limited#tools>.

19 216. BlackBerry has been damaged by Defendant's infringement of the '777  
20 Patent and will continue to be damaged unless Defendant is enjoined by this Court.  
21 BlackBerry has suffered and continues to suffer irreparable injury for which there is  
22 no adequate remedy at law. The balance of hardships favors BlackBerry, and public  
23 interest is not disserved by an injunction.

24 217. BlackBerry is entitled to recover from Defendant all damages that  
25 BlackBerry has sustained as a result of Defendant's infringement of the '777 Patent,  
26 including without limitation lost profits and not less than a reasonable royalty.  
27  
28

1 **PRAYER FOR RELIEF**

2 WHEREFORE, BlackBerry respectfully requests:

3 A. That Judgment be entered that Defendant has infringed one or more  
4 claims of the Patents-in-Suit, directly and indirectly, literally and/or under the  
5 doctrine of equivalents;

6 B. That, in accordance with 35 U.S.C. § 283, Defendant and all its  
7 affiliates, employees, agents, officers, directors, attorneys, successors, and assigns  
8 and all those acting on behalf of or in active concert or participation with it, be  
9 enjoined from (1) infringing the Patents-in-Suit and (2) making, using, selling, and  
10 offering for sale the Twitter application and Twitter Ads service and websites,  
11 and/or backend servers enabling the accused functionality of such applications,  
12 websites, and services, including without limitation Twitter's quality filters;

13 C. An order directing Defendant to file with the Court and serve upon  
14 BlackBerry's counsel within thirty (30) days after entry of the order of injunction, a  
15 report setting forth the manner and form in which Defendant has complied with the  
16 injunction, including the provision relating to destruction and recall of infringing  
17 products and materials;

18 D. An award of damages sufficient to compensate BlackBerry for  
19 Defendant's infringement under 35 U.S.C. § 284, including an enhancement of  
20 damages on account of Defendant's willful infringement;

21 E. That the case be found exceptional under 35 U.S.C. § 285 and that  
22 BlackBerry be awarded its reasonable attorneys' fees;

23 F. Costs and expenses in this action;

24 G. An award of prejudgment and post-judgment interest; and

25 H. Such other and further relief as the Court may deem just and proper.  
26  
27  
28

1  
2  
3  
4  
5  
6  
7  
8  
9  
10  
11  
12  
13  
14  
15  
16  
17  
18  
19  
20  
21  
22  
23  
24  
25  
26  
27  
28

DATED: June 4, 2019

QUINN EMANUEL URQUHART &  
SULLIVAN, LLP

Bv: /s/ James R. Asperger

James R. Asperger (Bar No. 83188)  
jamesasperger@quinnemanuel.com  
Yury Kapgan (Bar No. 218366)  
yurykapgan@quinnemanuel.com  
865 S. Figueroa Street, 10th Floor  
Los Angeles, CA 90017  
Telephone: (213) 443-3000  
Facsimile: (213) 443-3100

Victoria F. Maroulis (Bar No. 202603)  
victoriamaroulis@quinnemanuel.com  
555 Twin Dolphin Drive, 5th Floor  
Redwood Shores, CA 94065  
Telephone: (650) 801-5000  
Facsimile: (650) 801-5100

Jordan R. Jaffe (Bar No. 254886)  
jordanjaffe@quinnemanuel.com  
50 California Street, 22nd Floor  
San Francisco, CA 94111  
Telephone: (415) 875-6600  
Facsimile: (415) 875-6700

BLACKBERRY CORPORATION  
Edward R. McGah, Jr (Bar No. 97719)  
Vice President, Deputy General Counsel –  
Litigation  
41 Ticknor Place  
Laguna Niguel, California 92677  
Telephone: (650) 581-4750

Attorneys for Plaintiff, BlackBerry Limited

1  
2  
3  
4  
5  
6  
7  
8  
9  
10  
11  
12  
13  
14  
15  
16  
17  
18  
19  
20  
21  
22  
23  
24  
25  
26  
27  
28

**DEMAND FOR JURY TRIAL**

Pursuant to Rule 38(b) of the Federal Rules of Civil Procedure, BlackBerry respectfully demands a trial by jury on all issues triable by jury.

DATED: June 4, 2019

QUINN EMANUEL URQUHART &  
SULLIVAN, LLP

Bv: /s/ James R. Asperger

James R. Asperger (Bar No. 83188)  
jamesasperger@quinnemanuel.com  
Yury Kapgan (Bar No. 218366)  
yurykapgan@quinnemanuel.com  
865 S. Figueroa Street, 10th Floor  
Los Angeles, CA 90017  
Telephone: (213) 443-3000  
Facsimile: (213) 443-3100

Victoria F. Maroulis (Bar No. 202603)  
victoriamaroulis@quinnemanuel.com  
555 Twin Dolphin Drive, 5th Floor  
Redwood Shores, CA 94065  
Telephone: (650) 801-5000  
Facsimile: (650) 801-5100

Jordan R. Jaffe (Bar No. 254886)  
jordanjaffe@quinnemanuel.com  
50 California Street, 22nd Floor  
San Francisco, CA 94111  
Telephone: (415) 875-6600  
Facsimile: (415) 875-6700

BLACKBERRY CORPORATION  
Edward R. McGah, Jr (Bar No. 97719)  
Vice President, Deputy General Counsel –  
Litigation  
41 Ticknor Place  
Laguna Niguel, California 92677  
Telephone: (650) 581-4750

Attorneys for Plaintiff, BlackBerry Limited