

Dorian S. Berger (*pro hac vice*)
Daniel P. Hipskind (*pro hac vice*)
Eric B. Hanson (*pro hac vice* application to be filed)
BERGER & HIPSKIND LLP
9538 Brighton Way, Ste. 320
Beverly Hills, CA 90210
Telephone: 323-886-3430
Facsimile: 323-978-5508

Attorneys for Plaintiff
Dynamic Data Technologies, LLC

**UNITED STATES DISTRICT COURT
SOUTHERN DISTRICT OF NEW YORK**

-----X	:	
DYNAMIC DATA TECHNOLOGIES, LLC	:	
	:	Civil Action No. 1:18-cv-10454-AKH
Plaintiff,	:	
	:	COMPLAINT
v.	:	
	:	JURY TRIAL DEMANDED
DELL INC.	:	
	:	
Defendant.	:	
-----X	:	

FIRST AMENDED COMPLAINT FOR PATENT INFRINGEMENT

Dynamic Data Technologies, LLC (“Dynamic Data”) brings this action and makes the following allegations of patent infringement relating to U.S. Patent Nos.: 8,189,105 (the “105 patent”); 7,929,609 (the “609 patent”); 8,135,073 (the “073 patent”); 8,073,054 (the “054 patent”); 6,774,918 (the “918 patent”); 8,184,689 (the “689 patent”); 6,996,177 (the “177 patent”); 7,010,039 (the “039 patent”); 8,311,112 (the “112 patent”); 7,894,529 (the “529 patent”); 7,519,230 (the “230 patent”); 7,542,041 (the “041 patent”); 7,571,450 (the “450 patent”); and 7,750,979 (the “979 patent”) (collectively, the “patents-in-suit”). Defendant Dell Inc. (“Dell” or “Defendant”) infringes each of the patents-in-suit in violation of the patent laws of the United States of America, 35 U.S.C. § 1 *et seq.*

INTRODUCTION

1. Dynamic Data’s portfolio of over 1,200 patent assets encompasses core technologies in the field of image and video processing. The patent portfolio held by Dynamic Data is international in scope and includes several hundred European and Chinese patent grants.

2. Dynamic Data has expanded its portfolio of motion estimation and motion compensation patents. On November 19, 2018, Dynamic Data acquired a further set of 85 patent assets from NXP B.V. relating to motion estimation and motion compensation.

3. The groundbreaking inventions in image and video processing taught in the patents-in-suit were pioneered by Philips. Video and image processing were at the heart of Philips’ business for over fifty years. In 1891, Philips, then known as Philips & Company, was founded in Eindhoven, Netherlands to manufacture carbon-filament lamps.¹ In the 1920s, Philips began to produce vacuum tubes and small radios, which would augur Philips’ later entry into video and audio processing.



N.A. Halbertsma, *The Birth of a Lamp Factory In 1891*, PHILIPS TECHNICAL REVIEW, Vol. 23 at 230, 234 (1961).

¹ Gerard O’Regan, A BRIEF HISTORY OF COMPUTING at 99 (2012).

4. In 1962, Philips introduced the first audio cassette tape.² A year later, Philips launched a small battery-powered audio tape recorder that used a cassette instead of a loose spool.³ Philips C-cassette was later used as the first mass storage device for early personal computers in the 1970s and 1980s.

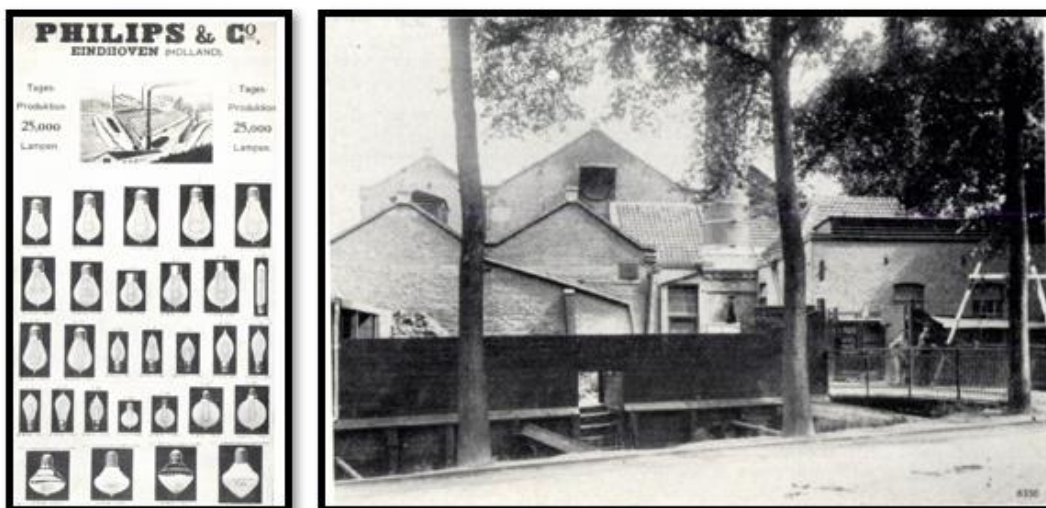

THE ROTARIAN MAGAZINE, Vol. 101 No. 6 at 70 (December 1962) (advertisement showing Philips Norelco device which used cassettes for recording audio for transcription); Fred Chandler, *European Mfrs. Bid For Market Share*, BILLBOARD MAGAZINE AT P-6 (April 8, 1967) (image of the Philips EL 3300 battery-operated tape recorder which was released in 1963); Jan Syrjala, *Car Stereo: How Does The Music Sound?*, N.Y. TIMES at 2-M (September 25, 1966) (showing Philips's Norelco Cassette "the Philips device has two tiny reels inside it, with the tape traveling from one to the other").

5. In 1971, Philips demonstrated the world's first videocassette records (VCR). A year later, Philips launched the world's first home video cassette recorder, the N1500. In 1982, Philips teamed with Sony to launch the Compact Disc; this format evolved into the DVD and later Blu-ray, which Philips launched with Sony in 1997 and 2006 respectively.

² Gerard O'Regan, PILLARS OF COMPUTING: A COMPENDIUM OF SELECT, PIVOTAL TECHNOLOGY FIRMS at 172 (2015) ("Philips invented the compact cassette for audio storage in 1962.")

³ Anthony Pollard, GRAMOPHONE: THE FIRST 75 YEARS at 231 (1998).

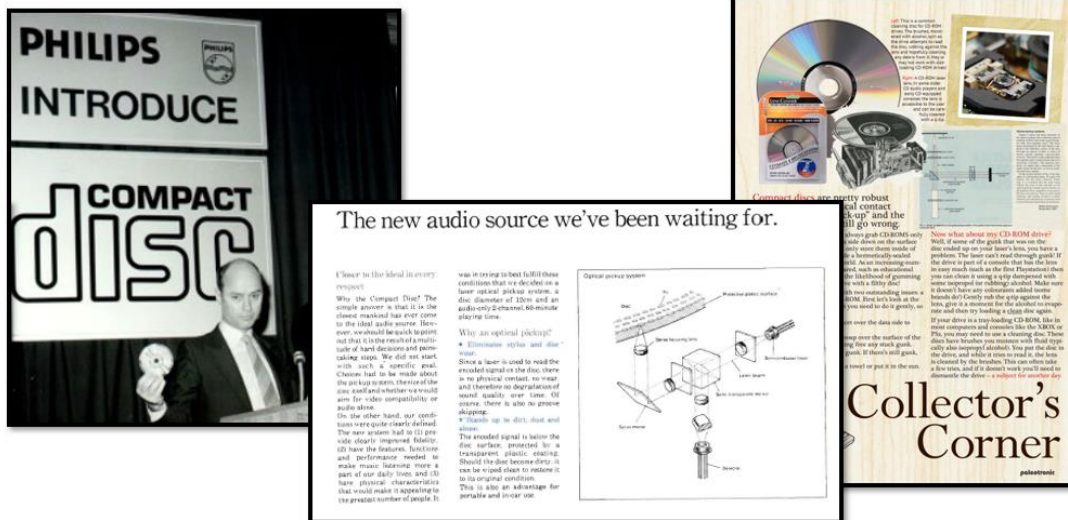

Hans Peek, Jan Bergmans, Jos Van Haaren, Frank Toolenaar, and Sorin Stan, ORIGINS AND SUCCESSORS OF THE COMPACT DISC: CONTRIBUTIONS OF PHILIPS TO OPTICAL STORAGE at 15 (2009) (showing image of Joop Sinjou of Philips introducing the compact disc in March 1979); Advertisements for Philip’s Compact Disc Products (1982).

6. In the late 1990s and early 2000s, Philips pioneered the development of technologies for encoding and decoding of video and audio content. At the time most of the technologies claimed by the patents in Dynamic Data’s portfolio were invented, Philips’ subsidiary primarily responsible for Philips’ work in this field, Philips Semiconductor was the world’s sixth largest semiconductor company.⁴ The video encoding technologies developed by Philips Semiconductor enable video streaming on set-top boxes, smartphones, popular gaming consoles, Internet-connected computers, and numerous other types of media streaming devices.

7. Philips Semiconductor dedicated significant research and development resources to advancing the technology of video compression and transmission by reducing file sizes and

⁴ *Company News; Philips in \$1 Billion Deal for VLSI Technology*, THE NEW YORK TIMES (May 4, 1999), available at: <https://www.nytimes.com/1999/05/04/business/company-news-philips-in-1-billion-deal-for-vlsi-technology.html>.

decreasing the processing resources required to transmit the data.⁵ Philips Semiconductor was among the first companies aggressively driving innovation in the field of video processing:

The late 1980s and early 1990s saw the announcement of several complex, programmable VSPs. Important examples include chips from Matsushita, NTT, Philips [Semiconductors], and NEC. All of these processors were high-performance parallel processors architected from the ground up for real-time video signal processing. . . . The Philips VSP-1 and NEC processor were probably the most heavily used of these chips.⁶

8. Starting in the 1960s Philips pioneered the development of audio and video technologies that would establish itself as a leader in the field that would later develop into the audio and video encoding fields. Continuing Philips' pioneering history in these fields, the patents-in-suit disclose cutting-edge video compression and transmission technologies.

DYNAMIC DATA'S PATENT PORTFOLIO

9. Dynamic Data's patent portfolio includes over 1,000 patent assets, with over 400 issued patents granted by patent offices around the world. Dynamic Data owns numerous patents issued by the United States Patent and Trademark Office, including each of the patents-in-suit, The State Intellectual Property Office of the People's Republic of China,⁷ the European Patent Office,⁸ the German Patent and Trademark Office,⁹ the Japan Patent Office,¹⁰ and many other national patent offices.

⁵ HU, YU HEN, PROGRAMMABLE DIGITAL SIGNAL PROCESSORS: ARCHITECTURE, PROGRAMMING, AND APPLICATIONS, at 190 (Dec. 6, 2001) ("Philips Semiconductors developed early dedicated video chips for specialized video processors.").

⁶ *Id.* at 191.

⁷ *See, e.g.*, CN100504925C; CN100438609C; CN1679052B; CN1333373C; CN1329870C; CN1303818C.

⁸ *See, e.g.*, European Patent Nos. EP1032921B1; EP1650978B1; EP1213700B1; EP1520409B1.

⁹ *See, e.g.*, German Patent Nos. DE60120762; DE50110537; DE60126151; DE60348978; DE602004049357.

¹⁰ *See, e.g.*, Japanese Patent Nos. JP4583924B2; JP5059855B2; JP5153336B2; JP4637585B2.

10. Philips Semiconductor's pioneering work in the area of video processing and encoding has resulted in various inventions that are fundamental to today's video processing technologies. Dynamic Data is the owner by assignment of over 1,000 of these patent assets, which include over 400 patents issued by patent offices around the world.

11. Highlighting the importance of the patents-in-suit is the fact that the patents-in-suit have been cited by over 400 U.S. and international patents and patent applications by a wide variety of the largest companies operating in the field. For example, the patents-in-suit have been cited by companies such as:

- Samsung Electronics Co., Ltd.¹¹
- Qualcomm Inc.¹²
- Google LLC¹³
- Intel Corporation¹⁴
- Broadcom Corporation¹⁵
- Microsoft Corporation¹⁶
- Sony Corporation¹⁷
- Fujitsu Ltd.¹⁸
- Panasonic Corporation¹⁹
- Matsushita Electric Industrial Company Limited²⁰

¹¹ See, e.g., U.S. Patent Nos. 6,930,729; 7,911,537; 7,532,764; 8,605,790; and 8,095,887.

¹² See, e.g., U.S. Patent Nos. 7,840,085; 8,649,437; 8,750,387; 8,918,533; 9,185,439; 9,209,934; 9,281,847; 9,319,448; 9,419,749; 9,843,844; 9,917,874; and 9,877,033.

¹³ See, e.g., U.S. Patent No. 8,787,454 and U.S. Patent Appl. No. 10/003,793.

¹⁴ See, e.g., U.S. Patent Nos. 7,554,559; 7,362,377; and 8,462,164.

¹⁵ See, e.g., U.S. Patent Nos. 8,325,273 and 9,377,987.

¹⁶ See, e.g., U.S. Patent Nos. 7,453,939; 7,670,227; 7,408,986; 7,421,129; 7,558,320; and 7,929,599.

¹⁷ See, e.g., U.S. Patent Nos. 7,218,354 and 8,174,615.

¹⁸ See, e.g., U.S. Patent Nos. 7,092,032 and 8,290,308.

¹⁹ See, e.g., U.S. Patent Nos. 8,164,687 and 8,432,495.

²⁰ See, e.g., U.S. Patent Nos. 7,362,378 and 7,423,961.

THE PARTIES

DYNAMIC DATA TECHNOLOGIES, LLC

12. Dynamic Data Technologies, LLC (“Dynamic Data” or “Plaintiff”) is a limited liability company organized under the laws of Delaware.

13. In an effort to obtain compensation for Philips’ pioneering work in the fields of video data encoding, decoding, and transmission, Dynamic Data acquired the patents-in-suit along with the several hundred additional issued United States and international Patents.

14. Dynamic Data pursues the reasonable royalties owed for Dell’s use of the inventions claimed in Dynamic Data’s patent portfolio, which primarily arise from Philips’ groundbreaking technology, both here in the United States and throughout the world.

DELL INC.

15. On information and belief, Dell Inc. (“Dell”) is a Delaware corporation with its principal place of business at One Dell Way, Round Rock, Texas 78682. Dell may be served through its registered agent Corporation Service Company, 251 Little Falls Drive, Wilmington, Delaware 19808.

16. On information and belief, Dell conducts business operations within the Southern District of New York, including in its facilities at One Penn Plaza, Suite 2920, New York, NY 10119.

JURISDICTION AND VENUE

17. This action arises under the patent laws of the United States, Title 35 of the United States Code. Accordingly, this Court has exclusive subject matter jurisdiction over this action under 28 U.S.C. §§ 1331 and 1338(a).

18. Upon information and belief, this Court has personal jurisdiction over Dell in this action because Dell has committed acts within the Southern District of New York giving rise to this action and has established minimum contacts with this forum such that the exercise of jurisdiction over Dell would not offend traditional notions of fair play and substantial justice. Defendant Dell, directly and/or through subsidiaries or intermediaries (including distributors, retailers, and others), has committed and continues to commit acts of infringement in this District by, among other things, offering to sell and selling products and/or services that infringe the patents-in-suit. Moreover, Dell has offices and facilities in the Southern District of New York, and actively directs its activities to customers located in the Southern District of New York.

19. Venue is proper in this district under 28 U.S.C. §§ 1391(b)-(d) and 1400(b). Defendant Dell has transacted business in the Southern District of New York and has committed acts of direct and indirect infringement in the Southern District of New York. On information and belief, Dell maintains one or more regular and established places of business in the Southern District of New York, including at least an office and facility at One Penn Plaza, Suite 2920, New York, NY 10019.

THE ASSERTED PATENTS

U.S. PATENT NO. 8,189,105

20. U.S. Patent No. 8,189,105 entitled, *Systems and Methods of Motion and Edge Adaptive Processing Including Motion Compensation Features*, was filed on October 17, 2007. The '105 Patent is subject to a 35 U.S.C. § 154(b) term extension of 1258 days. Dynamic Data is the owner by assignment of all right, title, and interest in the '105 Patent. A true and correct copy of the '105 Patent is attached hereto as Exhibit 1.

21. The '105 patent discloses novel systems and methods for processing pixel information based on received motion and edge data.

22. The '105 patent further discloses the use of a blending component (implemented by hardware, software, firmware, combinations thereof, etc.) that implements interpolating intensity of the pixel to equal to the first intensity estimate if motion reliability data is below a threshold.

23. The '105 patent in one embodiment teaches using segmentation to average four contiguous pixels into one averaged pixel segment during motion detection.

24. The '105 Patent and its underlying patent applications and foreign counterparts have been cited by 46 patents and patent applications as relevant prior art. Specifically, patents issued to the following companies have cited the '105 Patent and its underlying patent application as relevant prior art:

- Flextronics Ap, LLC
- Qingdao Hisense Electronics Co., Ltd.
- Hon Hai Precision Industry Co., Ltd.
- Intel Corporation
- Sony Corporation
- Fujitsu Corporation
- Himax Media Solutions, Inc.
- Ati Technologies Ulc
- Sharp Kabushiki Kaisha
- Xerox Corporation

U.S. PATENT NO. 7,929,609

25. U.S. Patent No. 7,929,609 (the "'609 patent") entitled, *Motion Estimation And/Or Compensation*, was filed on September 9, 2002, and claims priority to September 12, 2001. The '609 patent is subject to a 35 U.S.C. § 154(b) term extension of 1,242 days. Dynamic Data is the owner by assignment of all right, title, and interest in the '609 patent. A true and correct copy of the '609 patent is attached hereto as Exhibit 2.

26. The '609 patent discloses novel methods and systems for compensation and estimation of motion in video images.

27. The inventions disclosed in the '609 patent improve video signal processing functionality used in motion compensated prediction in encoding and compressing of digital video signals, motion compensated filtering in noise reduction, motion compensated interpolation in video format conversion, and motion compensated de-interlacing of interlaced video signals, among other video processing functionalities.

28. The '609 patent discloses a method of estimating or compensating motion in video images that includes using a video processor to select an image segment of a given video image.

29. The '609 patent discloses a method of estimating or compensating motion in video images that includes using the video processor to define an asymmetric search area surrounding the image segment based on ranges of possible motion vectors for the image segment.

30. The '609 patent discloses a method of estimating or compensating motion in video images that includes using the video processor to retrieve image data related to the asymmetric search area.

31. The '609 patent discloses a method of estimating or compensating motion in video images that includes a video processor that defines the asymmetric search area to have a center offset from a center of the image segment, the offset thereby defining asymmetry of the asymmetric search area, and statistically determines from an average vector of motion vectors established for one or more previous images.

32. The '609 patent and its underlying patent application have been cited by 64 patents and patent applications as relevant prior art. Specifically, patents issued to the following companies have cited the '609 patent and its underlying patent application as relevant prior art:

- Canon Inc.
- Xaxis Holdings, Inc.
- Samsung Electronics Co., Ltd.
- Electronics and Telecommunications Research Institute

- Broadcom Limited
- Sony Corporation
- Rakuten, Inc.
- Elan Microelectronics Corp.
- Garmin Ltd.
- State University System of Florida
- Ricoh Company Ltd.
- Intel Corporation
- Novatek Microelectronics Corp.
- Pearl River Hydraulic Research Institute

U.S. PATENT NO. 8,135,073

33. U.S. Patent No. 8,135,073 (the “’073 patent”) entitled, *Enhancing Video Images Depending On Prior Image Enhancements*, was filed on December 12, 2003, and claims priority to December 19, 2002. The ‘073 patent is subject to a 35 U.S.C. § 154(b) term extension of 1,799 days. Dynamic Data is the owner by assignment of all right, title, and interest in the ‘073 patent. A true and correct copy of the ‘073 patent is attached hereto as Exhibit 3.

34. The ‘073 patent discloses novel methods and systems for enhancing subsequent images of a video stream in which frames are encoded based on previous frames using prediction and motion estimation.

35. The inventions disclosed in the ‘073 patent reduce the processing capacity required for providing video enhancements to video processing through re-mapping of previous frames for subsequent frames.

36. Accordingly, the technologies disclosed in the ‘073 patent enable the provision of enhanced video pictures with minimal additional hardware costs for the components required to successfully process the video data.

37. The '073 patent discloses a video decoder comprising an input for receiving a video stream containing encoded frame based video information including an encoded first frame and an encoded second frame.

38. The '073 patent discloses a video decoder comprising an input for receiving video information wherein the encoding of the second frame depends on the encoding of the first frame, the encoding of the second frame includes motion vectors indicating differences in positions between regions of the second frame and corresponding regions of the first frame, the motion vectors define correspondence between regions of the second frame and corresponding regions of the first frame.

39. The '073 patent discloses a video decoder comprising a decoding unit for decoding the frames, wherein the decoding unit recovers the motion vectors for the second frame.

40. The '073 patent discloses a video decoder comprising a processing component configured to determine a re-mapping strategy for video enhancement of the decoded first frame using a region-based analysis, re-map the first frame using the re-mapping strategy, and re-map one or more regions of the second frame depending on the re-mapping strategy for corresponding regions of the first frame.

41. The '073 patent and its underlying patent application have been cited by 36 patents and patent applications as relevant prior art. Specifically, patents issued to the following companies have cited the '073 patent and its underlying patent application as relevant prior art:

- Canon Inc.
- Microsoft Corporation
- International Business Machines Corporation
- Qualcomm Inc.
- Digital Fountain Incorporated
- Samsung Electronics Co., Ltd.
- SK Planet Co. Ltd.

U.S. PATENT NO. 8,073,054

42. U.S. Patent No. 8,073,054 (the “’054 patent”) entitled, *Unit For And Method Of Estimating A Current Motion Vector*, was filed on December 12, 2002, and claims priority to January 17, 2002. The ‘054 patent is subject to a 35 U.S.C. § 154(b) term extension of 1,162 days. Dynamic Data is the owner by assignment of all right, title, and interest in the ‘054 patent. A true and correct copy of the ‘054 patent is attached hereto as Exhibit 4.

43. The ‘054 patent discloses novel methods and apparatuses for estimating a current motion vector for a group of pixels of an image.

44. The inventions disclosed in the ‘054 patent enable motion estimation with a relatively fast convergence in finding the appropriate motion vectors of the motion vector fields by adding a further candidate motion vector to the set of candidate motion vectors.

45. The ‘054 patent discloses a motion estimation unit comprising a generating unit for generating a set of candidate motion vectors for the group of pixels, with the candidate motion vectors being extracted from a set of previously estimated motion vectors.

46. The ‘054 patent discloses a motion estimation unit comprising a match error unit for calculating match errors of respective candidate motion vectors.

47. The ‘054 patent discloses a motion estimation unit comprising a selector for selecting the current motion vector from the candidate motion vectors by comparing the match errors of the respective candidate motion vectors, characterized in that the motion estimation unit is arranged to add a further candidate motion vector to the set of candidate motion vectors by calculating the further candidate motion vector on basis of a first motion vector and a second motion vector, both belonging to the set of previously estimated motion vectors.

48. The ‘054 patent discloses a motion estimation unit that calculates the further candidate motion vector on basis of the first motion vector and the second motion vector, with the

first motion vector belonging to a first forward motion vector field and the second motion vector belonging to a second forward motion vector field, with the first forward motion vector field and the second forward motion vector field being different.

49. The '054 patent discloses a motion estimation unit that arranges to calculate the further candidate motion vector by calculating a difference between the second motion vector and the first motion vector.

50. The '054 patent and its underlying patent application have been cited by 14 patents and patent applications as relevant prior art. Specifically, patents issued to the following companies have cited the '054 patent and its underlying patent application as relevant prior art:

- Canon Inc.
- Huawei Technologies, Ltd.
- Imagination Technologies Ltd.
- MediaTek Inc.
- Panasonic Corp.
- Samsung Electronics Co., Ltd.
- Siemens Healthcare GmbH
- Tencent Technology (Shenzhen) Co., Ltd.

U.S. PATENT NO. 6,774,918

51. U.S. Patent No. 6,774,918 (“the ‘918 patent”) entitled, *Video Overlay Processor with Reduced Memory And Bus Performance Requirements*, was filed on June 28, 2000. The ‘918 patent is subject to a 35 U.S.C. § 154(b) term extension of 591 days. Dynamic Data is the owner by assignment of all right, title, and interest in the ‘918 patent. A true and correct copy of the ‘918 patent is attached hereto as Exhibit 5.

52. The ‘918 patent claims specific methods and systems for providing an overlay such as a cursor in an on-screen display in a consumer electronic device. On-screen display (OSD) data

for generating an image on a display device are downloaded to an OSD unit on an integrated circuit.

53. The '918 patent discloses downloading on-screen display (OSD) data for generating an image on a display device.

54. The '918 patent further discloses downloading the on-screen display (OSD) data in segments separated by gaps.

55. The '918 patent further discloses, during a gap in downloading the on-screen display data, downloading an amount of overlay data for generating an overlay on the image generated on a display device.

56. Further, the '918 patent discloses that the overlay data downloaded during a gap comprises a portion of the overlay data.

57. The inventions disclosed in the '918 patent improve the operation and efficiency of computer components because only a portion of the overlay data is downloaded during each burst gap, thus reducing the amount of memory needed to store the overlay data. The inventions disclosed in the '918 patent further eliminate the requirement that on-chip memory be large enough to hold the data needed for an entire overlay. Instead, only one line or a part of one line of the overlay needs to be stored on-chip.

58. The '918 patent claims a technical solution to a problem unique to video processing.

59. The '918 patent has been cited by several United States patents and patent applications as relevant prior art. Specifically, patents issued to Realtek Semiconductor Corp., Samsung Electronics Co., Ltd., and Thomson Licensing SA have all cited the '918 patent as relevant prior art.

U.S. PATENT NO. 8,184,689

60. U.S. Patent No. 8,184,689 (the “‘689 patent”) entitled, *Method Video Encoding And Decoding Preserving Cache Localities*, was filed on August 7, 2006, and claims priority to August 17, 2005. The ‘689 patent is subject to a 35 U.S.C. § 154(b) term extension of 948 days. Dynamic Data is the owner by assignment of all right, title, and interest in the ‘689 patent. A true and correct copy of the ‘689 patent is attached hereto as Exhibit 6.

61. The ‘689 patent discloses novel methods and apparatuses for encoding and decoding video data.

62. The inventions disclosed in the ‘689 patent processing time and power consumption associated with encoding and decoding video stream data is reduced by reducing off-chip memory accesses through using simultaneous encoded/decoded images as a reference image for encoding/decoding at least one of the other simultaneously encoded/decoded images.

63. The ‘689 patent discloses a method for encoding and decoding a video stream, including a plurality of images in a video processing apparatus having a processing unit coupled to a first memory, further comprising a second memory.

64. The ‘689 patent discloses a method for encoding and decoding a video stream comprising providing a subset of image data stored in the second memory in the first memory.

65. The ‘689 patent discloses a method for encoding and decoding a video stream comprising simultaneous encoding/decoding of more than one image of the video stream, by accessing said subset, wherein the simultaneously encoding/decoding is performed by access sharing to at least one image.

66. The ‘689 patent and its underlying patent application have been cited by several patents and patent applications as relevant prior art. Specifically, patents issued to Fujitsu Ltd.,

Qualcomm Inc., Sony Corporation, Sun Patent Trust, and VIXS Systems Incorporated have all cited the '689 patent and its underlying patent application as relevant prior art.

U.S. PATENT NO. 6,996,177

67. U.S. Patent No. 6,996,177 (the “177 patent”) entitled, *Motion Estimation*, was filed on July 24, 2000, and claims priority to August 22, 1999. The '177 patent is subject to a 35 U.S.C. § 154(b) term extension of 1,103 days. Dynamic Data is the owner by assignment of all right, title, and interest in the '177 patent. A true and correct copy of the '177 patent is attached hereto as Exhibit 7.

68. The '177 patent claims specific methods and devices for motion estimation and motion-compensated picture signal processing.

69. The '177 patent discloses a motion vector estimation method and device that carries out a block-based motion vector estimation process that involves comparing a plurality of candidate vectors to determine block-based motion vectors.

70. The '177 patent discloses a motion vector estimation method and device that determines at least a most frequently occurring block-based motion vector.

71. The '177 patent discloses a motion vector estimation method and device that carries out a global motion vector estimation process using at least the most frequently occurring block-based motion vector to obtain a global motion vector.

72. The '177 patent discloses a motion vector estimation method and device that applies the global motion vector as a candidate vector to the block-based motion vector estimation process.

73. The inventions disclosed in the '177 patent improve the operation of the computer components necessary to the performance of picture signal processing by reducing the load on the central processing unit.

74. The '177 patent has been cited by 16 United States and International patents and patent applications as relevant prior art. Specifically, patents issued to the following companies have cited the '177 patent as relevant prior art:

- Qualcomm Incorporated
- LG Electronics
- Microsoft Corporation
- Samsung Electronics Co., Ltd.
- VIXS Systems Incorporated
- General Instrument Corporation

U.S. PATENT NO. 7,010,039

75. U.S. Patent No. 7,010,039 (the "'039 patent") entitled, *Motion Estimator for Reduced Halos in MC Up-Conversion*, was filed on May 15, 2001, and claims priority to May 18, 2000. The '039 patent is subject to a 35 U.S.C. § 154(b) term extension of 768 days. Dynamic Data is the owner by assignment of all right, title, and interest in the '039 patent. A true and correct copy of the '039 patent is attached hereto as Exhibit 8.

76. The '039 patent claims specific methods and apparatuses detecting motion at a temporal intermediate position between previous and next images. The inventions disclosed in the '039 patent solve a problem wherein an estimator estimating motion between two successive pictures from a video sequence cannot perform well in areas where covering or uncovering occurs.

77. The '039 patent solves this problem by carrying out the optimization at the temporal position of the next image in covering areas and at the temporal position of the previous image in uncovering areas.

78. The '039 patent discloses a method and apparatus for detecting motion at a temporal intermediate position between previous and next images.

79. The '039 patent discloses the use of a criterion function for selecting and optimizing candidate vectors.

80. The '039 patent further discloses a criterion function that depends on data from both previous and next images and in which the optimizing is carried out at the temporal intermediate position in non-covering and non-uncovering areas, characterized in that the optimizing is carried out at the temporal position of the next image in covering areas and at the temporal position of the previous image in uncovering areas.

81. The '039 patent and its related patents have been cited by 30 United States and International patents and patent applications as relevant prior art. Specifically, patents issued to the following companies have cited the '039 patent family as relevant prior art:

- Qualcomm Incorporated
- Panasonic Corporation
- Samsung Electronics Co., Ltd.
- Matsushita Electric Industrial Co., Ltd.
- Sharp Kabushiki Kaisha
- Integrated Device Technology, Inc.
- Zoran Corporation

U.S. PATENT NO. 8,311,112

82. U.S. Patent No. 8,311,112 (the "'112 patent") entitled, *System And Method For Video Compression Using Predictive Coding*, was filed on December 31, 2008. The '112 patent is subject to a 35 U.S.C. § 154(b) term extension of 847 days. Dynamic Data is the owner by assignment of all right, title, and interest in the '112 patent. A true and correct copy of the '112 patent is attached hereto as Exhibit 9.

83. The '112 patent discloses novel methods and systems for video compression.

84. The '112 patent discloses novel technologies for video compression that perform predictive coding on a macroblock of a video frame such that a set of pixels of the macroblock is coded using some of the pixels from the same video frame as reference pixels and the rest of the macroblock is coded using reference pixels from at least one other video frame.

85. The '112 patent discloses a system for video compression comprising an intra-frame coding unit configured to perform predictive coding on a set of pixels of a macroblock of pixels using a first group of reference pixels, the macroblock of pixels and the first group of reference pixels being from a video frame.

86. The '112 patent discloses a system for video compression comprising an inter-frame coding unit configured to perform predictive coding on the rest of the macroblock of pixels using a second group of reference pixels, the second group of reference pixels being from at least one other video frame.

87. The '112 patent and its underlying patent application have been cited by 10 patents and patent applications as relevant prior art. Specifically, patents issued to the following companies have cited the '112 patent and its underlying patent application as relevant prior art:

- British Broadcasting Corporation
- Google LLC
- Megachips Corp.
- Olympus Corp.
- Samsung Electronics Co., Ltd.
- Sony Corporation
- Toshiba Corporation

U.S. PATENT NO. 7,894,529

88. U.S. Patent No. 7,894,529 (the "'529 patent") entitled, *Method And Device For Determining Motion Vectors*, was filed on June 1, 2006, and claims priority to June 3, 2005. The '529 patent is subject to a 35 U.S.C. § 154(b) term extension of 1,301 days. Dynamic Data is the

owner by assignment of all right, title, and interest in the '529 patent. A true and correct copy of the '529 patent is attached hereto as Exhibit 10.

89. The '529 patent discloses novel methods and apparatuses for determining motion vectors that are each assigned to individual image regions.

90. The inventions disclosed in the '529 patent enable an increase in the resolution of video and image signals during the motion estimation process.

91. The '529 patent discloses a method for determining motion vectors which are assigned to individual image regions of an image.

92. The '529 patent discloses a method wherein an image is subdivided into a number of image blocks, and a motion estimation technique is implemented to assign at least one motion vector to each of the image blocks where a modified motion vector is generated for at least a first image block.

93. The '529 patent discloses a method that determines at least a second image block through which the motion vector assigned to the first image block at least partially passes.

94. The '529 patent discloses a method that generates the modified motion vector as a function of a motion vector assigned to at least the second image block.

95. The '529 patent discloses a method that assigns the modified motion vector as the motion vector to the first image block.

96. The '529 patent and its underlying patent application have been cited by multiple patents and patent applications as relevant prior art. Specifically, patents issued to Fujifilm Corp., and Samsung Electronics Co., Ltd. have cited the '529 patent and its underlying patent application as relevant prior art.

U.S. PATENT NO. 7,519,230

97. U.S. Patent No. 7,519,230 (the “‘230 patent”) entitled, *Background Motion Vector Detection*, was filed on December 16, 2003, and claims priority to January 23, 2003. The ‘230 patent is subject to a 35 U.S.C. § 154(b) term extension of 685 days. Dynamic Data is the owner of all right, title, and interest in the ‘230 patent. A true and correct copy of the ‘230 patent is attached hereto as Exhibit 11.

98. The ‘230 patent claims specific methods and systems to select a background motion vector for a pixel in an occlusion region of an image.

99. The ‘230 patent discloses systems and methods determine the correct motion vector in occlusion regions, thereby reducing or eliminating artifacts of motion compensated image rate converters, which are referred to as “halos” in the display of video images.

100. The ‘230 patent claims a method of selecting a background motion vector for a pixel in an occlusion region of an image comprising computing a model-based motion vector for the pixel on basis of a motion model being determined on basis of a part of a motion vector field of the image.

101. The ‘230 patent claims a method of selecting a background motion vector for a pixel in an occlusion region of an image comprising comparing the model-based motion vector with each of the motion vectors of the set of motion vectors.

102. The ‘230 patent claims a method of selecting a background motion vector for a pixel in an occlusion region of an image comprising selecting a particular motion vector of the set of motion vectors on basis of the comparing and for assigning the particular motion vector as the background motion vector.

103. The '230 patent has been cited by 28 United States and international patents and patent applications as relevant prior art. Specifically, patents issued to the following companies have cited the '230 patent as relevant prior art:

- Sony Corporation
- Fujitsu Ltd.
- Motorola Solutions Inc.
- Nokia Oyj
- Qualcomm Inc.
- Samsung Electronics Co., Ltd.
- Toshiba Corporation

U.S. PATENT NO. 7,542,041

104. U.S. Patent No. 7,542,041 (the "041 patent") entitled, *Runtime Configurable Virtual Video Pipeline*, was filed on April 2, 2004, and claims priority to April 3, 2003. The '041 patent is subject to a 35 U.S.C. § 154(b) term extension of 288 days. Dynamic Data is the owner by assignment of all right, title, and interest in the '041 patent. A true and correct copy of the '041 patent is attached hereto as Exhibit 12.

105. The '041 patent discloses novel systems for dynamically configuring a multi-pipe pipeline system.

106. The inventions disclosed in the '041 patent enable a multiple-pipeline system that is dynamically configurable to effect various combinations of functions for each pipeline.

107. The inventions disclosed in the '041 patent teach a multiple pipeline system that includes a pool of auxiliary function blocks that are provided as required to select pipelines.

108. In one embodiment of the '041 patent, each pipeline of the multiple-pipeline system is configured to include a homogenous set of core functions. A pool of auxiliary functions is provided for selective insertion of auxiliary functions between core functions of select pipelines.

109. In one embodiment of the '041 patent, each auxiliary function includes a multiplexer that allows it to be selectively coupled within each pipeline.

110. The '041 patent discloses, in one embodiment, a processing system that includes a plurality of pipelines, with each pipeline of the plurality including a plurality of core pipeline elements that are configured to sequentially process data as it traverses the pipeline.

111. The '041 patent discloses, in one embodiment, a processing system that includes a plurality of auxiliary elements, each auxiliary element of the plurality of auxiliary elements being configured to be selectively coupled to multiple pipelines of the plurality of pipelines.

112. The '041 patent discloses, in one embodiment, a processing system wherein the auxiliary elements are responsive to external coupling-select signals.

113. The '041 patent discloses, in one embodiment, a processing system wherein a plurality of auxiliary elements are within a selected pipeline of the multiple pipelines, between a pair of core pipeline elements of the plurality of core pipeline elements to process the data as it traverses between the pair of core elements.

114. The '041 patent has been cited by several United States patents and patent applications as relevant prior art. Specifically, patents and patent applications issued to Microsoft Corporation, Xilinx Inc., Canon Inc., Intel Corporation, and Nokia Oyj have cited the '041 patent and its underlying patent application as relevant prior art.

U.S. PATENT NO. 7,571,450

115. U.S. Patent No. 7,571,450 (the "'450 patent") entitled, *System For And Method Of Displaying Information*, was filed on February 12, 2003, and claims priority to March 11, 2002. The '450 patent is subject to a 35 U.S.C. § 154(b) term extension of 846 days. Dynamic Data is

the owner by assignment of all right, title, and interest in the '450 patent. A true and correct copy of the '450 patent is attached hereto as Exhibit 13.

116. The '450 patent discloses novel methods and systems for displaying information. The inventions disclosed in the '450 patent enable methods and systems wherein a user does not need to make a new selection after being switched from one service to a second service.

117. The inventions disclosed in the '450 patent permit a user of an information display system to have selections made on a first service also presented when the user switches to a second service without requiring the user to browse through the menus to define the type of information to be displayed a second time.

118. In one embodiment of the '450 patent, the user selection being made on the basis of the provided options while the first service was selected is use to select the appropriate data elements of the stream of the second service.

119. The inventions disclosed in the '450 patent enable various content sources to share similar information models.

120. The '450 patent, in one embodiment, discloses a method of displaying information on a display device wherein receiving a transport stream comprises services, with the services having elementary streams of video and of data elements.

121. The '450 patent, in one embodiment, discloses a method of displaying information on a display device wherein user actions of making a user selection of a type of information to be displayed on the device are received.

122. The '450 patent, in one embodiment, discloses a method of displaying information on a display device wherein filtering to select a data element of a first one of the services on the basis of the user selection is performed.

123. The '450 patent, in one embodiment, discloses a method of displaying information on a display device wherein rendering to calculate an output image to be displayed on the display device, on the basis of the first data element selected by the filter is performed.

124. The '450 patent, in one embodiment, discloses a method of displaying information on a display device wherein switching from the first one of the services to a second one of the services, characterized in comprising a second step of filtering to select a second data-element of the second one of the services, on basis of the user selection is performed.

125. The '450 patent, in one embodiment, discloses a method of displaying information on a display device wherein being switched from the first one of the services to the second one of the services, with the data-element and the second data-element being mutually semantically related and a second step of rendering to calculate the output image to be displayed on the display device, on basis of the second data-element selected by the filter is performed.

126. The '450 patent and its underlying patent application have been cited by several patents and patent applications as relevant prior art. Specifically, patents issued to AT&T Intellectual Property I LP, Nokia Oyj, Samsung Electronics Co., Ltd., and ZTE Corporation have all cited the '450 patent and its underlying patent application as relevant prior art.

U.S. PATENT NO. 7,750,979

127. U.S. Patent No. 7,750,979 (the "'979 patent") entitled, *Pixel-Data Line Buffer Approach Having Variable Sampling Patterns*, was filed on October 26, 2001. The '979 patent is subject to a 35 U.S.C. § 154(b) term extension of 2,749 days. Dynamic Data is the owner by assignment of all right, title, and interest in the '979 patent. A true and correct copy of the '979 patent is attached hereto as Exhibit 14.

128. The '979 patent discloses novel methods and systems for motion compensation in video signal processing.

129. The '979 patent discloses methods and systems that use line buffers that are decoupled and that can deliver a fixed number of pixels, as may be required by a video processing stage, using a sampling pattern that is defined as one among several selectable sampling windows.

130. The '979 patent discloses a video processing circuit having an input stream of pixels corresponding to an array of video pixels.

131. The '979 patent further discloses having a variable window size for sampling subsets of the array as a two-dimensional window that spans the pixels in the array.

132. The '979 patent further discloses having a video processing stage that inputs pixels using a fixed number of pixels.

133. The '979 patent further discloses a method for delivering the input stream of pixels to the video processing stage.

134. The '979 patent further discloses a method comprising establishing a window size and a sampling-window size, such that the window size is a multiple of the sampling-window size and the sampling-window size defines the fixed number of pixels.

135. The '979 patent further discloses a method comprising storing pixels from the input stream into a first set of line buffers, the pixels stored in the first set of line buffers including pixels for the established window size.

136. The '979 patent further discloses a method comprising prefetching the stored pixels from the first set of line buffers into a second set of line buffers, the second set of line buffers being sufficiently long to store at least the pixels corresponding to the established sampling-window size.

137. The '979 patent further discloses a method comprising fetching the fixed number of pixels from the second set of line buffers for the video processing stage.

COUNT I
INFRINGEMENT OF U.S. PATENT NO. 8,189,105

138. Dynamic Data references and incorporates by reference the preceding paragraphs of this Complaint as if fully set forth herein.

139. Dell designs, makes, uses, sells, and/or offers for sale in the United States products and/or services for processing pixel information based on received motion and edge data.

140. Dell designs, makes, sells, offers to sell, imports, and/or uses Dell graphic processors containing H.265/High Efficiency Video Coding (“HEVC”) processing functionality, including: Dell G3 3579, Dell G3 3779, Dell G5 15 5587, Dell G7 15 7588, Inspiron 14 Gaming 7466, Inspiron 14 Gaming 7467, Inspiron 15 Gaming 7566, Inspiron 15 Gaming 7567, Inspiron 15 Gaming 7577, Inspiron 5457, Inspiron 5458, Inspiron 5557, Inspiron 5558, Inspiron 5587, Inspiron 5758, Inspiron 7447, Inspiron 7460, Inspiron 7466, Inspiron 7472, Inspiron 7557, Inspiron 7559, Inspiron 7560, Inspiron 7566, Inspiron 7572, Inspiron 7588, Inspiron Desktop 3470, Inspiron Desktop 3670, Inspiron Desktop 5676, Inspiron Desktop 5680, Latitude 3190, Latitude 3190 2-in-1, Latitude 5420, Latitude 5424, Latitude 5491, Latitude 5591, Latitude 7424, Optiplex 3060, Optiplex 5060, Optiplex 5260 AIO, Optiplex 7060, Optiplex 7460 AIO, Optiplex 7760 AIO, Optiplex XE3, Precision 3430, Precision 3430 XL Tower, Precision 3530, Precision 3630, Precision 3630 XL Tower, Precision 3930 Rack, Precision 3930 XL RACK, Precision 5510, Precision 5520, Precision 5530, Precision 7530, Precision 7730, Precision M3800, Vostro Desktop 3470, Vostro Desktop 3670, Vostro Notebook 3458, Vostro Notebook 3558, Vostro Notebook 5459, Vostro Notebook 5468, Vostro Notebook 5480, Vostro Notebook 5568, Vostro Notebook 7580, XPS 13 9360, XPS 13 9365 2-in-1, XPS 13 9370, XPS 15 9550, XPS 15 9560, XPS 15

9570, XPS 15 9575 2-in-1, XPS Desktop XPS 8930, XPS Notebook 9365, XPS Notebook 9530, XPS Notebook 9550, XPS Notebook 9560, XPS Notebook 9570, Dell Advanced Projector S718QL, Alienware 15, Alienware 15 R2-R4, Alienware 17, Alienware 17 R2-R5, Alienware 18, Alienware Area 51, Alienware Area-51 ALX, Alienware Area-51 R2-R5 & R7, Alienware Area-51 Threadripper Edition R3 & R6 & R7, Alienware Aurora, Alienware Aurora ALX, Alienware Aurora R2-R8, Alienware m15, Alienware M15x, Alienware M17x, Alienware M17x R2-R4, Alienware M18x, Alienware M18x R2, Alienware X51, and Alienware X51 R2 & R3 (collectively, the “Dell ‘105 Product(s)”).

141. The Dell ‘105 Products perform video processing compliant with the HEVC standard. *See e.g., Dell Desktop Support*, DELL SUPPORT WEBSITE, available at: <https://www.dell.com/support/home/us/en/19/products/desktop>; *Dell Laptop Support*, DELL SUPPORT WEBSITE, available at: <https://www.dell.com/support/home/us/en/19/products/laptop>

142. The below table shows Dell ‘105 Products that contain the infringing HEVC compliant video processing technology.

Exemplar Dell Models	Graphics Processing Unit (GPU)	HEVC Decode/Encode ²¹
Dell G3 3579	NVIDIA GeForce GTX 1050 Ti ²²	Yes
Dell G3 3779	NVIDIA GeForce GTX 1060 w/ Max Q ²³	Yes
Dell G5 15 5587	NVIDIA GeForce GTX 1060 w/ Max Q ²⁴	Yes

²¹ *NVIDIA Video Encode And Decode GPU Support Matrix*, NVIDIA DEVELOPER WEBSITE, available at: <https://developer.nvidia.com/video-encode-decode-gpu-support-matrix> (showing support for HEVC in NVIDIA Graphics cards); *Intel Product Matrix*, INTEL WEBSITE, available at: <https://www.intel.com/content/www/us/en/products> (showing HEVC Support); *Intel Graphics Product Specifications*, INTEL WEBSITE, available at: <https://www.intel.com/content/www/us/en/architecture-and-technology/visual-technology/graphics-overview.html>.

²² *Dell Model G3 3579*, DELL WEBSITE, available at: <https://www.dell.com/en-us/work/shop/dell-laptops-and-notebooks/dell-g3-15-gaming-laptop/spd/g-series-15-3579-laptop>

²³ *Dell Model G3 3779*, DELL WEBSITE, available at: <https://www.dell.com/en-us/shop/dell-laptops/dell-g3-17-gaming/spd/g-series-17-3779-laptop>

²⁴ *Dell Model G5 15 5587*, DELL WEBSITE, available at: <https://www.dell.com/en-us/shop/dell-laptops/dell-g5-15-gaming/spd/g-series-15-5587-laptop>

Dell G7 15 7588	NVIDIA GeForce GTX 1060 w/ Max Q ²⁵	Yes
Inspiron 14 Gaming 7466	Intel HD Graphics 530 ²⁶	Yes
Inspiron 14 Gaming 7467	Intel HD Graphics 630 ²⁷	Yes
Inspiron 15 Gaming 7566	Intel HD Graphics 530 (Integrated) / NVIDIA GeForce GTX630M (Discrete) ²⁸	Yes
Inspiron 15 Gaming 7567	NVIDIA GeForce GTX 1050Ti with 4GB GDDR5 / NVIDIA GeForce GTX 1050 with 4GB GDDR5 ²⁹	Yes
Inspiron 15 Gaming 7577	Intel HD Graphics 630 (Integrated) / NVIDIA GeForce GTX 1050/ GTX 1050 Ti/ GTX 1060 Max-Q (Discrete) ³⁰	Yes
Inspiron 5457	Intel HD Graphics 520 (integrated) / NVIDIA GeForce 930M (Discrete) ³¹	Yes
Inspiron 5458	Intel HD Graphics 4400/4500 (integrated) / NVIDIA GeForce 920M (discrete) ³²	Yes
Inspiron 5557	Intel HD Graphics 520 (integrated) / NVIDIA GeForce 930M (discrete) ³³	Yes
Inspiron 5558	Intel HD Graphics 4400/4500 (integrated) / NVIDIA GeForce 920M (discrete) ³⁴	Yes
Inspiron 5587	NVIDIA GeForce GTX 1060 Max-Q ³⁵	Yes
Inspiron 5758	Intel HD Graphics 4400/4500 (integrated) / NVIDIA GeForce 920M (discrete) ³⁶	Yes
Inspiron 7447	Intel Iris Pro Graphic 5200 (integrated) / NVIDIA GeForce GTX 850M (discrete) ³⁷	Yes
Inspiron 7460	Intel HD Graphics 610/620/635 (integrated)/ NVIDIA GeForce 940M ³⁸	Yes

²⁵ *Dell Model G7 15 7588*, DELL WEBSITE, available at: <https://www.dell.com/en-us/shop/dell-laptops/dell-g7-15-gaming/spd/g-series-15-7588-laptop>

²⁶ *Dell Inspiron 14 Gaming Setup and Specifications*, DELL MANUAL MODEL NO. INSPIRON 14-7466 at 18 (2016).

²⁷ *Dell Inspiron 14 7000 Gaming Series Setup and Specifications*, DELL SPECIFICATIONS MODEL NO. INSPIRON 14-7467 at 18 (2016)

²⁸ *Dell Inspiron 15 Gaming Setup and Specifications*, DELL MANUAL MODEL NO. 15-7566 at 18 (2016)

²⁹ *Dell Inspiron Model 7567*, DELL WEBSITE, available at: <https://www.dell.com/us/dfh/p/inspiron-15-7567-laptop/pd>

³⁰ *Dell Inspiron 15 7000 Gaming Setup and Specifications*, DELL MANUAL MODEL NO. INSPIRON 15-7577 at 23 (2018).

³¹ *Dell Inspiron 14 5000 Series Specification*, DELL SPECIFICATIONS MODEL NO. INSPIRON 14-5457 at 12 (2015).

³² *Dell Inspiron 14 5000 Series Specification*, DELL SPECIFICATIONS MODEL NO. INSPIRON 14-5458 at 12 (2015).

³³ *Dell Inspiron 14 5000 Series Specification*, DELL SPECIFICATIONS MODEL NO. INSPIRON 14-5557 at 12 (2015).

³⁴ *Dell Inspiron 14 5000 Series Specification*, DELL SPECIFICATIONS MODEL NO. INSPIRON 14-5558 at 12 (2015).

³⁵ *Dell Inspiron Model 5587*, DELL WEBSITE, available at: <https://www.dell.com/en-us/shop/dell-laptops/dell-g5-15-gaming/spd/g-series-15-5587-laptop>

³⁶ *Dell Inspiron 17 5000 Series Specification*, DELL SPECIFICATIONS MODEL NO. INSPIRON 17-5758 at 12 (2015).

³⁷ *Dell Inspiron 14 7000 Series Specification*, DELL SPECIFICATIONS MODEL NO. INSPIRON 7447 at 12 (2014).

³⁸ *Dell Inspiron 14 7000 Setup and Specification*, DELL MANUAL MODEL NO. INSPIRON 14-7460 at 18 (2018)

Inspiron 7466	Intel HD Graphics 530 (integrated) / NVIDIA GeForce GTX 950M ³⁹	Yes
Alienware Area 51	NVIDIA GeForce RTX 2080 Ti OC with 11GB GDDR6 ⁴⁰	Yes
Alienware Area-51 R2	NVIDIA® GeForce GTX ⁴¹	Yes
Alienware Area-51 R4/R5	NVIDIA® GeForce GTX ⁴²	Yes
Alienware Area-51 Threadripper R3/R6	NVIDIA GeForce GTX 1080 ⁴³	Yes
Alienware Area-51 Threadripper Edition R7	Dual NVIDIA® GeForce® RTX 2080 Ti OC ⁴⁴	Yes
Alienware Aurora	NVIDIA® GeForce® RTX 2080 Ti OC with 11GB GDDR6 ⁴⁵	Yes

143. Dell documentation states that the Dell ‘105 Products are compliant with the HEVC standard as shown in the following excerpts.

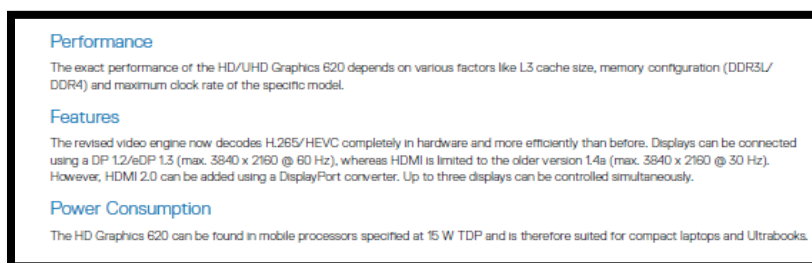

DELL LATITUDE 5420 RUGGED OWNER’S MANUAL at 44 (2015) (“The revised video engine now decodes H.265/HEVC completely in hardware and more efficiently than before.”).

³⁹ *Dell Inspiron 14 Gaming Setup and Specifications*, DELL MANUAL MODEL NO. INSPIRON 14-7466 at 18 (2016).

⁴⁰ *Dell Alienware Specifications*, DELL WEBSITE, available at: <https://www.dell.com/en-us/shop/dell-desktop-computers/alienware-area-51/spd/alienware-area51-r5>

⁴¹ *Dell Alienware Specifications*, DELL WEBSITE, available at: <https://www.dell.com/en-us/shop/cty/pdp/spd/alienware-area51-r2>

⁴² *Dell Alienware Specifications*, DELL WEBSITE, available at: <https://www.dell.com/en-us/shop/dell-desktop-computers/alienware-area-51-gaming-desktop/spd/alienware-area51-r4>

⁴³ *Dell Alienware Specifications*, DELL WEBSITE, available at: <https://www.dell.com/en-us/shop/dell-desktop-computers/alienware-area-51-threadripper-edition/spd/alienware-area51-r6>

⁴⁴ *Dell Alienware Specifications*, DELL WEBSITE, available at: <https://www.dell.com/en-us/shop/desktops/area-51-threadripper/spd/alienware-area51-r7>

⁴⁵ *Dell Alienware Specifications*, DELL WEBSITE, available at: <https://www.dell.com/en-us/shop/dell-desktop-computers/alienware-aurora/spd/alienware-aurora-r7-desktop>

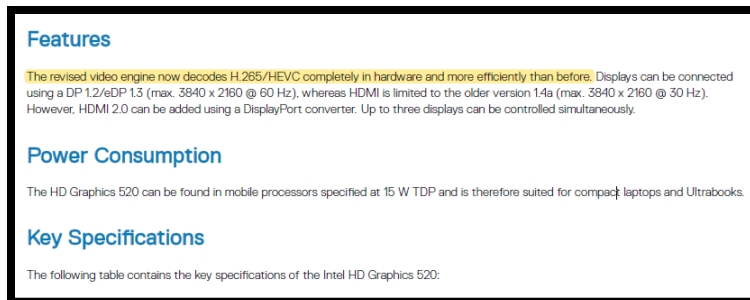

DELL VOSTRO 14-3468 OWNER’S MANUAL at 55 (2018) (annotation added) (“The revised video engine now decodes H.265/HEVC completely in hardware and more efficiently than before.”).

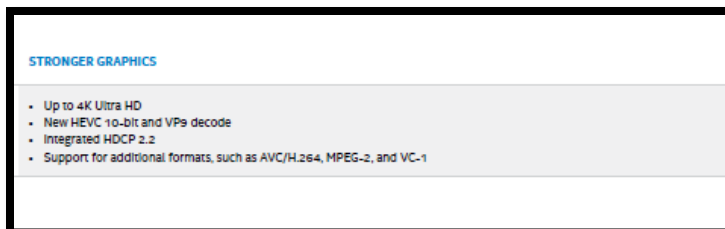

DELL PRODUCT QUICK REFERENCE MATRIX Q4 2018 at 17 (2018) (“New HEVC 10-bit and VP9 decode”).

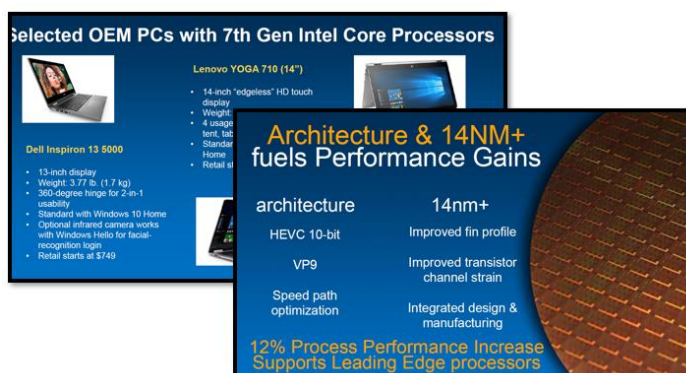

David Bradshaw, 7th Generation Intel Core Processor, INTEL PRESENTATION at 3 & 12 (2016).

144. On information and belief, one or more Dell subsidiaries and/or affiliates use the Dell ‘105 Products in regular business operations.

145. On information and belief, by complying with the HEVC standard, the Dell devices – such as the Dell ‘105 Products – necessarily infringe the ‘105 patent. The mandatory sections of the HEVC standard require the elements required by certain claims of the ‘105 patent, including but not limited to claim 1 of the ‘105 patent. *High Efficiency Video Coding, SERIES H:*

AUDIOVISUAL AND Multimedia SYSTEMS: INFRASTRUCTURE OF AUDIOVISUAL SERVICES – CODING OF MOVING VIDEO REC. ITU-T H.265 (February 2018) (The following sections of the HEVC Standard are relevant to Dell’s infringement of the ‘105 patent: “8.3.2 Decoding process for reference picture set;” “8.5.4 Decoding process for the residual signal of coding units coded in inter prediction mode;” “8.6 Scaling, transformation and array construction process prior to deblocking filter process;” “8.5.2 Inter prediction process;” “8.5.3 Decoding process for prediction units in inter prediction mode;” and “8.7.2 Deblocking filter process;” “8.7.3 Sample adaptive offset process.”).

146. On information and belief, the Dell ‘105 Products comply with the HEVC standard, which requires processing edge data from edge-adaptive interpolation processing.

147. The Dell ‘105 Products use two types of prediction methods for processing pixel information when encoding and decoding video data in HEVC format: inter prediction and intra prediction. Inter prediction utilizes motion vectors for block-based inter prediction to exploit temporal statistical dependencies between different pictures. Intra prediction uses various spatial prediction modes to exploit spatial statistical dependencies in the source signal for a single picture. The HEVC Specification (*e.g.*, *High Efficiency Video Coding*, SERIES H: AUDIOVISUAL AND MULTIMEDIA SYSTEMS: INFRASTRUCTURE OF AUDIOVISUAL SERVICES – CODING OF MOVING VIDEO REC. ITU-T H.265 (February 2018) sets forth the standard that is followed by HEVC compliant devices such as the Dell ‘105 Products, and is relevant to both decoding and encoding that are performed pursuant to the HEVC standard. For instance, the Dell ‘105 Products perform a method for encoding a video signal comprised of pixels using motion vectors when performing encoding of H.265/HEVC video data.

148. During the encoding process the Dell '105 products process pixel information based on edge data. The edge data is generated by the Dell '105 products using merge mode estimation. Specifically, the Dell '105 Products generate merge estimation regions which identify edge information within a video frame. The merge estimation regions are comprised of prediction units ("PU") that contain luma values. For example, in the below diagram PUs are shown. The encoding process then identifies along the edges of each prediction unit a merge estimation region ("MER"). The MER regions thus identify the edges and the PU contains the intensity estimate for the pixels.

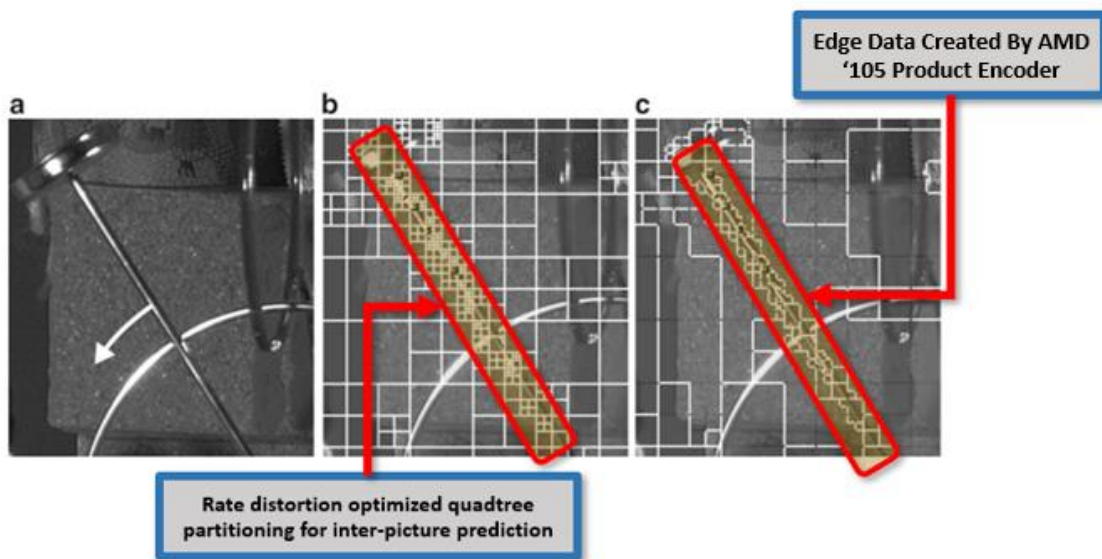

Benjamin Bross et al, *Inter-Picture Prediction in HEVC*, HIGH EFFICIENCY VIDEO CODING (HEVC) at 114 (September 2014) (annotations added).

149. The Dell '105 Products in the process of encoding video content in HEVC format generate merge estimation regions generate edge data that include luma location and luma values which include a first intensity estimate. The HEVC standards describes this process as leading to the generation of luma motion vector mvL0 and mvL1.

[T]he derivation process for luma motion vectors for merge mode as specified in clause I.8.5.3.2.7 is invoked with the luma location (xCb, yCb), the luma location (xPb, yPb), the variables nCbS, nPbW, nPbH, and the partition index partIdx as inputs, and the output being the luma motion vectors mvL0, mvL1, the reference

indices refIdxL0, refIdxL1, the prediction list utilization flags predFlagL0 and predFlagL1, the flag ivMcFlag, the flag vspMcFlag, and the flag subPbMotionFlag.

High Efficiency Video Coding, SERIES H: AUDIOVISUAL AND MULTIMEDIA SYSTEMS: INFRASTRUCTURE OF AUDIOVISUAL SERVICES – CODING OF MOVING VIDEO REC. ITU-T H.265 at § I.8.5.3.2.1 (February 2018) (emphasis added).

150. The Dell ‘105 Products perform the step of processing edge data from an edge adaptive interpolation process wherein the edge data includes a first intensity estimate of the pixel. Specifically, the Dell ‘105 Products implement HEVC encoding which utilizes Parallel Merge Mode and Merge Estimation Regions (MER’s) within the interpolation process to determine pixel edges. Parallel Merge Mode Estimation identifies the edge data within a prediction unit. The below diagram shows how video data is portioned into 10 prediction units and edge data is calculated and passed to the encoder.

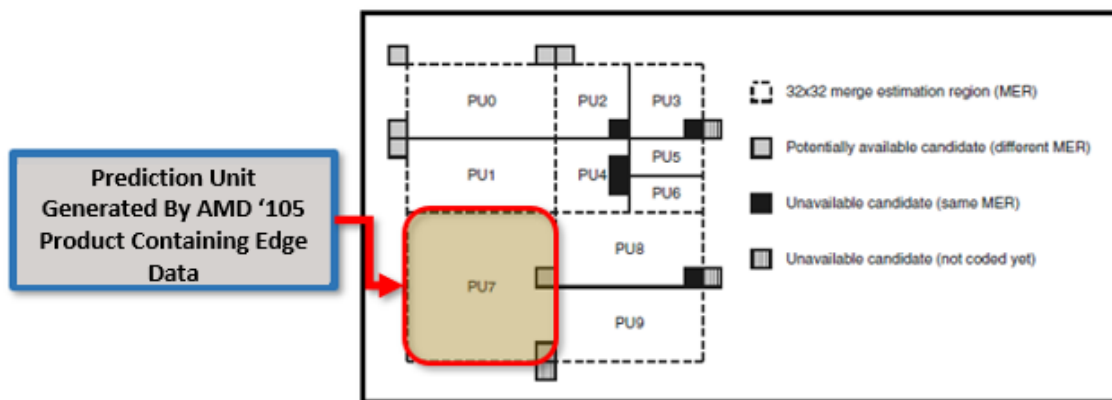

Benjamin Bross et al, *Inter-Picture Prediction in HEVC*, HIGH EFFICIENCY VIDEO CODING (HEVC) at 127 (September 2014) (annotations added).

151. The merge estimation processes implemented by the Dell ‘105 Products is “adaptive.” The below excerpt from documentation regarding the HEVC encoding process describes that the “merge estimation level is adaptive.”

In order to enable an encoder to trade-off parallelism and coding efficiency, the parallel merge estimation level is adaptive and signaled as $\log_2 \text{parallel_merge_level_minus2}$ in the picture parameter set. The following MER sizes are allowed: 4×4 (no parallel merge estimation possible), 8×8 , 16×16 , 32×32 and 64×64 . A higher degree of parallelization, enabled by a larger MER, excludes more potential candidates from the merge candidate list.

Benjamin Bross et al, *Inter-Picture Prediction in HEVC*, HIGH EFFICIENCY VIDEO CODING (HEVC) at 128 (September 2014) (emphasis added).

152. The edge data that is processed from the edge adaptive interpolation process includes intensity estimates for pixels such as pixels in the merge estimation region. The intensity estimate or brightness estimate is referred to as “luma” in the encoding functionality implemented by the Dell ‘105 Products.

For representing color video signals, HEVC typically uses a tristimulus YCbCr color space with 4:2:0 sampling (although extension to other sampling formats is straightforward, and is planned to be defined in a subsequent version). This separates a color representation into three components called Y, Cb, and Cr. The Y component is also called luma, and represents brightness. The two chroma components Cb and Cr represent the extent to which the color deviates from gray toward blue and red, respectively. Because the human visual system is more

Gary J. Sullivan, Jens-Rainer Ohm, Woo-Jin Han, and Thomas Wiegand, Fellow, IEEE, *Overview of the High Efficiency Video Coding (HEVC) Standard*, published in IEEE TRANSACTIONS ON CIRCUITS AND SYSTEMS FOR VIDEO TECHNOLOGY, Vol. 22, No. 12 at 1654 (December 2012) (emphasis added).

153. The motion estimation region (“MER”) is an adaptive interpolation process in which the edges of images are calculated and include the intensity estimates of pixels by way of a luma value. The below excerpt from the HEVC specification describes how during the generation of merge estimation regions edge data includes luminosity values (intensity estimates) for pixels within a region.

8.5.3.2.3 Derivation process for spatial merging candidates

Inputs to this process are:

- a luma location (x_{Cb} , y_{Cb}) of the top-left sample of the current luma coding block relative to the top-left luma sample of the current picture,
- a variable $nCbS$ specifying the size of the current luma coding block,
- a luma location (x_{Pb} , y_{Pb}) specifying the top-left sample of the current luma prediction block relative to the top-left luma sample of the current picture,
- two variables $nPbW$ and $nPbH$ specifying the width and the height of the luma prediction block,
- a variable $partIdx$ specifying the index of the current prediction unit within the current coding unit.

Outputs of this process are as follows, with X being 0 or 1:

- the availability flags $availableFlagA_0$, $availableFlagA_1$, $availableFlagB_0$, $availableFlagB_1$ and $availableFlagB_2$ of the neighbouring prediction units,
- the reference indices $refIdxLXA_0$, $refIdxLXA_1$, $refIdxLXB_0$, $refIdxLXB_1$ and $refIdxLXB_2$ of the neighbouring prediction units,
- the prediction list utilization flags $predFlagLXA_0$, $predFlagLXA_1$, $predFlagLXB_0$, $predFlagLXB_1$ and $predFlagLXB_2$ of the neighbouring prediction units,
- the motion vectors $mvLXA_0$, $mvLXA_1$, $mvLXB_0$, $mvLXB_1$ and $mvLXB_2$ of the neighbouring prediction units.

High Efficiency Video Coding, Series H: Audiovisual And Multimedia Systems: Infrastructure Of Audiovisual Services – Coding Of Moving Video Rec. ITU-T H.265 at § I.8.5.2.3 (February 2018) (emphasis added).

154. The Dell ‘105 Products process motion data associated with motion compensation. The motion data processed by the Dell ‘105 Products include a first estimated motion vector of pixels within a reference frame prior to the current frame and a second estimated motion vector within the reference field after the current field. Specifically, the Dell ‘105 products generate motion data in the form of a bi-directional prediction unit (PU) which has two motion vectors (referencing a prior frame and a subsequent frame in the sequence). The two motion vectors are combined to make a “bi-predictive merge candidate.” One of the motion vectors is obtained from “reference picture list0” and the other motion vector is obtained from “reference picture list1.”

8.5.3.3.2 Reference picture selection process

Input to this process is a reference index refIdxLX .

Output of this process is a reference picture consisting of a two-dimensional array of luma samples refPicLX_L and, when ChromaArrayType is not equal to 0, two two-dimensional arrays of chroma samples refPicLX_{Cb} and refPicLX_{Cr} .

The output reference picture $\text{RefPicListX}[\text{refIdxLX}]$ consists of a $\text{pic_width_in_luma_samples}$ by $\text{pic_height_in_luma_samples}$ array of luma samples refPicLX_L and, when ChromaArrayType is not equal to 0, two $\text{PicWidthInSamplesC}$ by $\text{PicHeightInSamplesC}$ arrays of chroma samples refPicLX_{Cb} and refPicLX_{Cr} .

The reference picture sample arrays refPicLX_L , refPicLX_{Cb} , and refPicLX_{Cr} correspond to decoded sample arrays S_L , S_{Cb} , and S_{Cr} derived in clause 8.7 for a previously-decoded picture.

High Efficiency Video Coding, SERIES H: AUDIOVISUAL AND MULTIMEDIA SYSTEMS: INFRASTRUCTURE OF AUDIOVISUAL SERVICES – CODING OF MOVING VIDEO REC. ITU-T H.265 at § I.8.5.3.3 (February 2018).

155. The reference pictures that are used to generate a motion vector comprise both the forward and prior reference pictures which are referred to in the HEVC encoding process implemented by the Dell ‘105 Products as “ refPicLX_{cb} ” and “ refPicLX_{cr} .” The following excerpt describing the implementation of the encoding process in the Dell ‘105 Products which use bi-predictive slices.

Since a merge candidate comprises all motion data and the TMVP is only one motion vector, the derivation of the whole motion data only depends on the slice type. For bi-predictive slices, a TMVP is derived for each reference picture list. Depending on the availability of the TMVP for each list, the prediction type is set to bi-prediction or to the list for which the TMVP is available. All associated reference picture indices are set equal to zero. Consequently for uni-predictive slices, only the TMVP for list 0 is derived together with the reference picture index equal to zero.

Benjamin Bross et al, *Inter-Picture Prediction in HEVC*, HIGH EFFICIENCY VIDEO CODING (HEVC) at 123 (September 2014) (emphasis added) (describing the use of bi-prediction in which motion data is derived from the forward and prior reference pictures in generating temporal arrays/vectors).

156. The Dell ‘105 Products interpolation process contains bi-prediction functionality that computes a first estimated motion prediction and a second estimated motion prediction. The below excerpt from documentation of the encoding method used by the Dell ‘105 products describes that the encoding process includes functionality for generating a second intensity estimate for the pixel data and the edge data determined according to motion. In bi-prediction, the second estimate is defined as Δx_1 , Δy_1 , Δt_1 .

In case of bi-prediction, two sets of motion data ($\Delta x_0, \Delta y_0, \Delta t_0$ and $\Delta x_1, \Delta y_1, \Delta t_1$) are used to generate two MCPs (possibly from different pictures), which are then combined to get the final MCP. Per default, this is done by averaging but in case of weighted prediction, different weights can be applied to each MCP, e.g. to compensate for scene fade outs. The reference pictures that can be used in bi-prediction are stored in two separate lists, namely list 0 and list 1. In order to limit the memory bandwidth in slices allowing bi-prediction, the HEVC standard restricts PUs with 4×8 and 8×4 luma prediction blocks to use uni-prediction only. Motion data is derived at the encoder using a motion estimation process. Motion

Benjamin Bross et al, *Inter-Picture Prediction in HEVC*, HIGH EFFICIENCY VIDEO CODING (HEVC) at 114 (September 2014) (emphasis added).

157. In AMVP the system generates a temporal intermediate candidate based on bi-directional motion data. The “inter_pred_idc [x0] [y0] specifies whether list0, list1, or bi-prediction is used for the current prediction unit” according to the below referenced table. “The array indices x0, y0 specify the location (x0, y0) of the top-left luma sample of the considered prediction block relative to the top-left luma sample of the picture.”

Table 7-11 – Name association to inter prediction mode

inter_pred_idc	Name of inter_pred_idc	
	(nPbW + nPbH) != 12	(nPbW + nPbH) == 12
0	PRED_L0	PRED_L0
1	PRED_L1	PRED_L1
2	PRED_BI	na

High Efficiency Video Coding, SERIES H: AUDIOVISUAL AND MULTIMEDIA SYSTEMS: INFRASTRUCTURE OF AUDIOVISUAL SERVICES – CODING OF MOVING VIDEO REC. ITU-T H.265 at § 7.4.9.6 (February 2018).

158. The Dell ‘105 products generate a second intensity estimate based on the edge data and the motion data. The edge data is combined with the temporal intermediate candidate to generate the temporal candidate. The prediction unit based on the first and second motion vector (motion data) is then combined with the edge data to generate a second intensity estimate. Once the reference picture for obtaining the co-located PU is selected then the position of the co-located

Pu will be selected among two candidate positions. A second intensity estimate is generated by using the bi-directional motion vectors and the edge data. The below excerpt from the HEVC specification describes that for a luma motion vector prediction the generation of a second intensity estimate is based on the motion data and the edge data. The edge data here is comprised by the luma location and luma prediction block information. Further, the luma motion vectors mvLO and mvL1 are combined with the edge data including luma location xCB yCB xBL and yBL to generate a second intensity estimate.

8.5.3.2.6 Derivation process for luma motion vector prediction

Inputs to this process are:

- a luma location (xCb, yCb) of the top-left sample of the current luma coding block relative to the top-left luma sample of the current picture.
- a variable nCbS specifying the size of the current luma coding block.
- a luma location (xPb, yPb) specifying the top-left sample of the current luma prediction block relative to the top-left luma sample of the current picture.
- two variables nPbW and nPbH specifying the width and the height of the luma prediction block.
- the reference index of the current prediction unit partition refIdxLX, with X being 0 or 1,
- a variable partIdx specifying the index of the current prediction unit within the current coding unit.

Output of this process is the prediction mvPLX of the motion vector mvLX, with X being 0 or 1.

High Efficiency Video Coding, SERIES H: AUDIOVISUAL AND MULTIMEDIA SYSTEMS: INFRASTRUCTURE OF AUDIOVISUAL SERVICES – CODING OF MOVING VIDEO REC. ITU-T H.265 at § 8.5.3.2.6 (February 2018) (emphasis added).

8.5.3.3.1 General

Inputs to this process are:

- a luma location (x_{Cb} , y_{Cb}) specifying the top-left sample of the current luma coding block relative to the top-left luma sample of the current picture,
- a luma location (x_{Bl} , y_{Bl}) specifying the top-left sample of the current luma prediction block relative to the top-left sample of the current luma coding block,
- a variable n_{CbS} specifying the size of the current luma coding block,
- two variables n_{PbW} and n_{PbH} specifying the width and the height of the luma prediction block,
- the luma motion vectors mv_{L0} and mv_{L1} ,
- when $ChromaArrayType$ is not equal to 0, the chroma motion vectors mv_{CL0} and mv_{CL1} ,
- the reference indices $refIdx_{L0}$ and $refIdx_{L1}$,
- the prediction list utilization flags, $predFlag_{L0}$, and $predFlag_{L1}$.

Outputs of this process are:

- an $(n_{CbS_L}) \times (n_{CbS_L})$ array $predSamples_L$ of luma prediction samples, where n_{CbS_L} is derived as specified below,
- when $ChromaArrayType$ is not equal to 0, an $(n_{CbSw_C}) \times (n_{CbSh_C})$ array $predSamples_{Cb}$ of chroma prediction samples for the component Cb , where n_{CbSw_C} and n_{CbSh_C} are derived as specified below,

High Efficiency Video Coding, SERIES H: AUDIOVISUAL AND MULTIMEDIA SYSTEMS: INFRASTRUCTURE OF AUDIOVISUAL SERVICES – CODING OF MOVING VIDEO REC. ITU-T H.265 at § 8.5.3.3.1 (February 2018) (emphasis added).

159. The Dell ‘105 Products perform a mixing process in which the final edge/motion data of a pixel is calculated based on a first intensity estimate, second intensity estimate, and motion reliability data. Specifically, the Dell ‘105 Products encode pixel data using bi-prediction wherein use two types of mixing functions: average mixing and weighted mixing.

In case of bi-prediction, two sets of motion data ($\Delta x_0, \Delta y_0, \Delta t_0$ and $\Delta x_1, \Delta y_1, \Delta t_1$) are used to generate two MCPs (possibly from different pictures), which are then combined to get the final MCP. Per default, this is done by averaging but in case of weighted prediction, different weights can be applied to each MCP, e.g. to compensate for scene fade outs. The reference pictures that can be used in bi-prediction are stored in two separate lists, namely list 0 and list 1. In order to limit the memory bandwidth in slices allowing bi-prediction, the HEVC standard restricts PUs with 4×8 and 8×4 luma prediction blocks to use uni-prediction only. Motion data is derived at the encoder using a motion estimation process. Motion

Benjamin Bross et al, *Inter-Picture Prediction in HEVC*, HIGH EFFICIENCY VIDEO CODING (HEVC) at 123 (September 2014) (emphasis added).

160. The HEVC standard includes functionality to perform a mixing process. In MERGE mode, an up-to five-entry MERGE candidate list is first constructed with four (MV, RefIdx) pairs from spatial neighbor blocks and one (MV, RefIdx) pair from temporal bottom-right

or collocated neighbor block, where RefIdx is the index of the reference picture that the MV pointed to. After that, the encoder decides to use which candidate (MV, RefIdx) pair to encode current block and then encode the candidate index into bitstream. In MERGE mode, the selected (MV, RefIdx) pair is directly used to encode current block, and no MVD information needs to be coded. The number of merge candidates could be configured at encoder, with up to five merge candidates.”

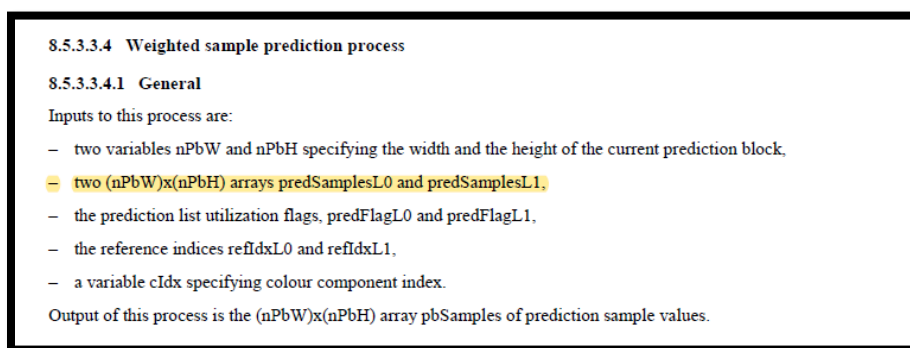

HIGH EFFICIENCY VIDEO CODING, SERIES H: AUDIOVISUAL AND MULTIMEDIA SYSTEMS: INFRASTRUCTURE OF AUDIOVISUAL SERVICES – CODING OF MOVING VIDEO REC. ITU-T H.265 at § 8.5.3.3.4.1 (February 2018) (emphasis added).

161. The variables predFlagL0 and predFlagL1 are reliability values that are generated by the decoding process. The predFlagL0 and L1 values are prediction utilization values that are used to generate prediction utilization and reliability of the vectors.

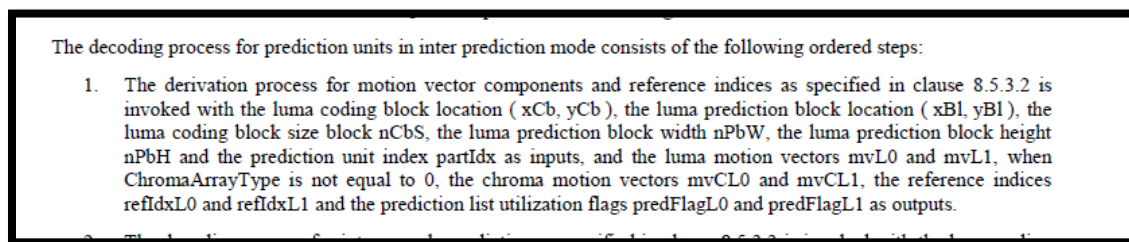

High Efficiency Video Coding, SERIES H: AUDIOVISUAL AND MULTIMEDIA SYSTEMS: INFRASTRUCTURE OF AUDIOVISUAL SERVICES – CODING OF MOVING VIDEO REC. ITU-T H.265 at § 8.5.3.1 (February 2018).

162. On information and belief, any implementation of the HEVC standard would infringe the ‘105 patent as every possible implementation of the standard requires: processing edge

data from edge-adaptive interpolation processing, including a first intensity estimate for the pixel as well as data pertaining to one or more pixels that neighbor the pixel; processing motion data associated with motion compensation processing, wherein the motion data includes a first estimated motion vector for a pixel in a reference field prior to the present field and a second estimated motion vector for a pixel in a reference field subsequent to the present field; determining a second intensity estimate for the pixel as a function of the edge data and the motion data; and performing a blending process wherein final edge/motion data of the pixel is calculated as a function of the first intensity estimate, the second intensity estimate, and motion reliability data characterizing reliability of the motion data.

163. On information and belief, the Dell ‘105 Products are available to businesses and individuals throughout the United States.

164. On information and belief, the Dell ‘105 Products are provided to businesses and individuals located in the Southern District of New York.

165. By making, using, testing, offering for sale, and/or selling products and services for enhancing subsequent images of a video stream in which frames are encoded based on previous frames using prediction and motion estimation, including but not limited to the Dell ‘105 Products, Dell has injured Dynamic Data and is liable to the Plaintiff for directly infringing one or more claims of the ‘105 patent, including at least claim 1 pursuant to 35 U.S.C. § 271(a).

166. On information and belief, Dell also indirectly infringes the ‘105 patent by actively inducing infringement under 35 U.S.C. § 271(b).

167. Dell has had knowledge of the ‘105 patent since at least service of this First Amended Complaint or shortly thereafter, and on information and belief, Dell knew of the ‘105 patent and knew of its infringement, including by way of this lawsuit.

168. On information and belief, Dell intended to induce patent infringement by third-party customers and users of the Dell ‘105 Products and had knowledge that the inducing acts would cause infringement or was willfully blind to the possibility that its inducing acts would cause infringement. Dell specifically intended and was aware that the normal and customary use of the accused products would infringe the ‘105 patent. Dell performed the acts that constitute induced infringement, and would induce actual infringement, with knowledge of the ‘105 patent and with the knowledge that the induced acts would constitute infringement. For example, Dell provides the Dell ‘105 Products that have the capability of operating in a manner that infringe one or more of the claims of the ‘105 patent, including at least claim 1, and Dell further provides documentation and training materials that cause customers and end users of the Dell ‘105 Products to utilize the products in a manner that directly infringe one or more claims of the ‘105 patent.⁴⁶ By providing instruction and training to customers and end-users on how to use the Dell ‘105 Products in a manner that directly infringes one or more claims of the ‘105 patent, including at least claim 1, Dell specifically intended to induce infringement of the ‘105 patent. On information and belief, Dell engaged in such inducement to promote the sales of the Dell ‘105 Products, e.g., through Dell user manuals, product support, marketing materials, and training materials to actively induce the users of the accused products to infringe the ‘105 patent. Accordingly, Dell has induced and continues to induce users of the accused products to use the accused products in their ordinary and customary way to infringe the ‘105 patent, knowing that such use constitutes infringement of the ‘105 patent.

⁴⁶ See, e.g., *Dell G7 15*, SETUP AND SPECIFICATIONS (2018); *Alienware Graphics Amplifier*, USER’S GUIDE (2014); *Alienware Aurora R8*, SETUP AND SPECIFICATIONS (2018); *Inspiron 15 7000 Gaming*, SERVICE MANUAL (2017-2018); *XPS 13*, SETUP AND SPECIFICATIONS (2017); *Dell Latitude 5420/E5420/E5420m*, OWNER’S MANUAL (2011); *Alienware M17x R4*, OWNER’S MANUAL (2012); *Dell Vostro 15-3558*, OWNER’S MANUAL (2015).

169. The '105 patent is well-known within the industry as demonstrated by multiple citations to the '105 patent in published patents and patent applications assigned to technology companies and academic institutions. Dell is utilizing the technology claimed in the '105 patent without paying a reasonable royalty. Dell is infringing the '105 patent in a manner best described as willful, wanton, malicious, in bad faith, deliberate, consciously wrongful, flagrant, or characteristic of a pirate.

170. To the extent applicable, the requirements of 35 U.S.C. § 287(a) have been met with respect to the '105 patent.

171. As a result of Dell's infringement of the '105 patent, Dynamic Data has suffered monetary damages, and seeks recovery in an amount adequate to compensate for Dell's infringement, but in no event less than a reasonable royalty for the use made of the invention by Dell together with interest and costs as fixed by the Court.

COUNT II
INFRINGEMENT OF U.S. PATENT NO. 7,929,609

172. Dynamic Data references and incorporates by reference the preceding paragraphs of this Complaint as if fully set forth herein.

173. Intel designs, makes, uses, sells, and/or offers for sale in the United States products and/or services for compensation and estimation of motion in video images.

174. Dell designs, makes, sells, offers to sell, imports, and/or uses Dell devices that contain H.265 video compression functionality, including but not limited to Dell desktops, laptops, and all-in-one devices including the following exemplary models: Dell G3 3579, Dell G3 3779, Dell G5 15 5587, Dell G7 15 7588, Dell Precision 5530, Inspiron 14 Gaming 7466, Inspiron 14 Gaming 7467, Inspiron 15 Gaming 7566, Inspiron 15 Gaming 7567, Inspiron 15 Gaming 7577,

Inspiron 7472, Inspiron 7572, Inspiron G3 3579, Inspiron G3 3779, Latitude 3190, Latitude 3190 2-in-1, Latitude 5420, Latitude 5424, Latitude 5491, Latitude 5591, Latitude 7424, Optiplex 3060, Optiplex 5060, Optiplex 5260 AIO, Optiplex 7060, Optiplex 7460 AIO, Optiplex 7760 AIO, Optiplex XE3, Precision 3430, Precision 3430 XL Tower, Precision 3530, Precision 3630, Precision 3630 XL Tower, Precision 3930 Rack, Precision 3930 XL RACK, Precision 5510, Precision 5520, Precision 5530, Precision 7530, Precision 7730, Precision M3800, XPS 13 9360, XPS 13 9365 2-in-1, XPS 13 9370, XPS 15 9550, XPS 15 9560, XPS 15 9570, XPS 15 9575 2-in-1, XPS Notebook 9365, XPS Notebook 9530, XPS Notebook 9550, XPS Notebook 9560, and, XPS Notebook 9570, Alienware 15, Alienware 15 R2, Alienware 15 R3, Alienware 15 R4, Alienware 17, Alienware 17 R2, Alienware 17 R3, Alienware 17 R4, Alienware 17 R5, Alienware 18, Alienware Area 51, Alienware Area-51 ALX, Alienware Area-51 R2, Alienware Area-51 R4 and R5, Alienware Area-51 Threadripper Edition R3 and R6, Alienware Area-51 Threadripper Edition R7, Alienware Aurora, Alienware Aurora ALX, Alienware Aurora R2, Alienware Aurora R3, Alienware Aurora R4, Alienware Aurora R5, Alienware Aurora R6, Alienware Aurora R7, Alienware Aurora R8, Alienware m15, Alienware M15x, Alienware M17x, Alienware M17x R2, Alienware M17x R3, Alienware M17x R4, Alienware M18x, Alienware M18x R2, Alienware X51, Alienware X51 R2, and Alienware X51 R3 (collectively, the “Dell ‘609 Product(s)”).

175. The Dell ‘609 Products perform video processing compliant with the HEVC standard. *See e.g., Dell Desktop Support, DELL SUPPORT WEBSITE, available at: <https://www.dell.com/support/home/us/en/19/products/desktop>; Dell Laptop Support, DELL SUPPORT WEBSITE, available at: <https://www.dell.com/support/home/us/en/19/products/laptop>*

176. The below table shows Dell ‘609 Products that contain the infringing HEVC compliant video processing technology.

Exemplar Dell Models	Graphics Processing Unit (GPU)	HEVC Decode/Encode ⁴⁷
Dell G3 3579	NVIDIA GeForce GTX 1050 Ti ⁴⁸	Yes
Dell G3 3779	NVIDIA GeForce GTX 1060 w/ Max Q ⁴⁹	Yes
Dell G5 15 5587	NVIDIA GeForce GTX 1060 w/ Max Q ⁵⁰	Yes
Dell G7 15 7588	NVIDIA GeForce GTX 1060 w/ Max Q ⁵¹	Yes
Inspiron 14 Gaming 7466	Intel HD Graphics 530 ⁵²	Yes
Inspiron 14 Gaming 7467	Intel HD Graphics 630 ⁵³	Yes
Inspiron 15 Gaming 7566	Intel HD Graphics 530 (Integrated) / NVIDIA GeForce GTX630M (Discrete) ⁵⁴	Yes
Inspiron 15 Gaming 7567	NVIDIA GeForce GTX 1050Ti with 4GB GDDR5 / NVIDIA GeForce GTX 1050 with 4GB GDDR5 ⁵⁵	Yes
Inspiron 15 Gaming 7577	Intel HD Graphics 630 (Integrated) / NVIDIA GeForce GTX 1050/ GTX 1050 Ti/ GTX 1060 Max-Q (Discrete) ⁵⁶	Yes
Inspiron 5457	Intel HD Graphics 520 (integrated) / NVIDIA GeForce 930M (Discrete) ⁵⁷	Yes
Inspiron 5458	Intel HD Graphics 4400/4500 (integrated) / NVIDIA GeForce 920M (discrete) ⁵⁸	Yes
Inspiron 5557	Intel HD Graphics 520 (integrated) / NVIDIA GeForce 930M (discrete) ⁵⁹	Yes

⁴⁷ *NVIDIA Video Encode And Decode GPU Support Matrix*, NVIDIA DEVELOPER WEBSITE, available at: <https://developer.nvidia.com/video-encode-decode-gpu-support-matrix> (showing support for HEVC in NVIDIA Graphics cards); *Intel Product Matrix*, INTEL WEBSITE, available at: <https://www.intel.com/content/www/us/en/products> (showing HEVC Support); *Intel Graphics Product Specifications*, INTEL WEBSITE, available at: <https://www.intel.com/content/www/us/en/architecture-and-technology/visual-technology/graphics-overview.html>.

⁴⁸ *Dell Model G3 3579*, DELL WEBSITE, available at: <https://www.dell.com/en-us/work/shop/dell-laptops-and-notebooks/dell-g3-15-gaming-laptop/spd/g-series-15-3579-laptop>

⁴⁹ *Dell Model G3 3779*, DELL WEBSITE, available at: <https://www.dell.com/en-us/shop/dell-laptops/dell-g3-17-gaming/spd/g-series-17-3779-laptop>

⁵⁰ *Dell Model G5 15 5587*, DELL WEBSITE, available at: <https://www.dell.com/en-us/shop/dell-laptops/dell-g5-15-gaming/spd/g-series-15-5587-laptop>

⁵¹ *Dell Model G7 15 7588*, DELL WEBSITE, available at: <https://www.dell.com/en-us/shop/dell-laptops/dell-g7-15-gaming/spd/g-series-15-7588-laptop>

⁵² *Dell Inspiron 14 Gaming Setup and Specifications*, DELL MANUAL MODEL NO. INSPIRON 14-7466 at 18 (2016).

⁵³ *Dell Inspiron 14 7000 Gaming Series Setup and Specifications*, DELL SPECIFICATIONS MODEL NO. INSPIRON 14-7467 at 18 (2016)

⁵⁴ *Dell Inspiron 15 Gaming Setup and Specifications*, DELL MANUAL MODEL NO. 15-7566 at 18 (2016)

⁵⁵ *Dell Inspiron Model 7567*, DELL WEBSITE, available at: <https://www.dell.com/us/dfh/p/inspiron-15-7567-laptop/pd>

⁵⁶ *Dell Inspiron 15 7000 Gaming Setup and Specifications*, DELL MANUAL MODEL NO. INSPIRON 15-7577 at 23 (2018).

⁵⁷ *Dell Inspiron 14 5000 Series Specification*, DELL SPECIFICATIONS MODEL NO. INSPIRON 14-5457 at 12 (2015).

⁵⁸ *Dell Inspiron 14 5000 Series Specification*, DELL SPECIFICATIONS MODEL NO. INSPIRON 14-5458 at 12 (2015).

⁵⁹ *Dell Inspiron 14 5000 Series Specification*, DELL SPECIFICATIONS MODEL NO. INSPIRON 14-5557 at 12 (2015).

Inspiron 5558	Intel HD Graphics 4400/4500 (integrated) / NVIDIA GeForce 920M (discrete) ⁶⁰	Yes
Inspiron 5587	NVIDIA GeForce GTX 1060 Max-Q ⁶¹	Yes
Inspiron 5758	Intel HD Graphics 4400/4500 (integrated) / NVIDIA GeForce 920M (discrete) ⁶²	Yes
Inspiron 7447	Intel Iris Pro Graphic 5200 (integrated) / NVIDIA GeForce GTX 850M (discrete) ⁶³	Yes
Inspiron 7460	Intel HD Graphics 610/620/635 (integrated)/ NVIDIA GeForce 940M ⁶⁴	Yes
Inspiron 7466	Intel HD Graphics 530 (integrated) / NVIDIA GeForce GTX 950M ⁶⁵	Yes
Alienware Area 51	NVIDIA GeForce RTX 2080 Ti OC with 11GB GDDR6 ⁶⁶	Yes
Alienware Area-51 R2	NVIDIA® GeForce GTX ⁶⁷	Yes
Alienware Area-51 R4/R5	NVIDIA® GeForce GTX ⁶⁸	Yes
Alienware Area-51 Threadripper R3/R6	NVIDIA GeForce GTX 1080 ⁶⁹	Yes
Alienware Area-51 Threadripper Edition R7	Dual NVIDIA® GeForce® RTX 2080 Ti OC ⁷⁰	Yes
Alienware Aurora	NVIDIA® GeForce® RTX 2080 Ti OC with 11GB GDDR6 ⁷¹	Yes

177. Dell documentation states that the Dell ‘609 Products are compliant with the HEVC standard as shown in the following excerpts.

⁶⁰ *Dell Inspiron 14 5000 Series Specification*, DELL SPECIFICATIONS MODEL NO. INSPIRON 14-5558 at 12 (2015).

⁶¹ *Dell Inspiron Model 5587*, DELL WEBSITE, available at: <https://www.dell.com/en-us/shop/dell-laptops/dell-g5-15-gaming/spd/g-series-15-5587-laptop>

⁶² *Dell Inspiron 17 5000 Series Specification*, DELL SPECIFICATIONS MODEL NO. INSPIRON 17-5758 at 12 (2015).

⁶³ *Dell Inspiron 14 7000 Series Specification*, DELL SPECIFICATIONS MODEL NO. INSPIRON 7447 at 12 (2014).

⁶⁴ *Dell Inspiron 14 7000 Setup and Specification*, DELL MANUAL MODEL NO. INSPIRON 14-7460 at 18 (2018)

⁶⁵ *Dell Inspiron 14 Gaming Setup and Specifications*, DELL MANUAL MODEL NO. INSPIRON 14-7466 at 18 (2016).

⁶⁶ *Dell Alienware Specifications*, DELL WEBSITE, available at: <https://www.dell.com/en-us/shop/dell-desktop-computers/alienware-area-51/spd/alienware-area51-r5>

⁶⁷ *Dell Alienware Specifications*, DELL WEBSITE, available at: <https://www.dell.com/en-us/shop/cty/pdp/spd/alienware-area51-r2>

⁶⁸ *Dell Alienware Specifications*, DELL WEBSITE, available at: <https://www.dell.com/en-us/shop/dell-desktop-computers/alienware-area-51-gaming-desktop/spd/alienware-area51-r4>

⁶⁹ *Dell Alienware Specifications*, DELL WEBSITE, available at: <https://www.dell.com/en-us/shop/dell-desktop-computers/alienware-area-51-threadripper-edition/spd/alienware-area51-r6>

⁷⁰ *Dell Alienware Specifications*, DELL WEBSITE, available at: <https://www.dell.com/en-us/shop/desktops/area-51-threadripper/spd/alienware-area51-r7>

⁷¹ *Dell Alienware Specifications*, DELL WEBSITE, available at: <https://www.dell.com/en-us/shop/dell-desktop-computers/alienware-aurora/spd/alienware-aurora-r7-desktop>

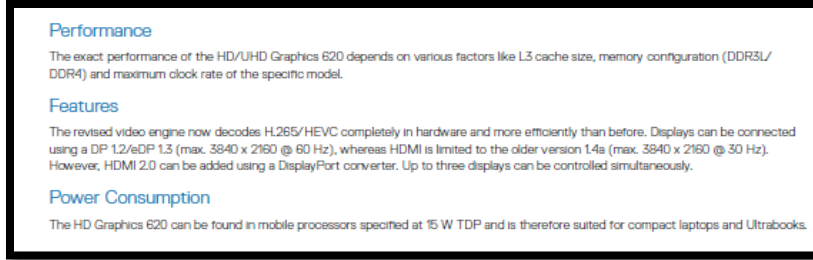

DELL LATITUDE 5420 RUGGED OWNER’S MANUAL at 44 (2015) (“The revised video engine now decodes H.265/HEVC completely in hardware and more efficiently than before.”).

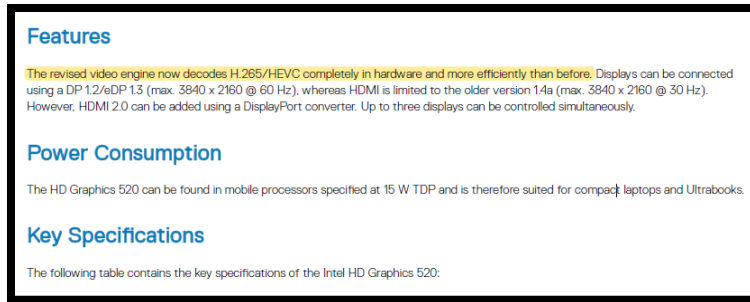

DELL VOSTRO 14-3468 OWNER’S MANUAL at 55 (2018) (annotation added) (“The revised video engine now decodes H.265/HEVC completely in hardware and more efficiently than before.”).



DELL PRODUCT QUICK REFERENCE MATRIX Q4 2018 at 17 (2018) (“New HEVC 10-bit and VP9 decode”).

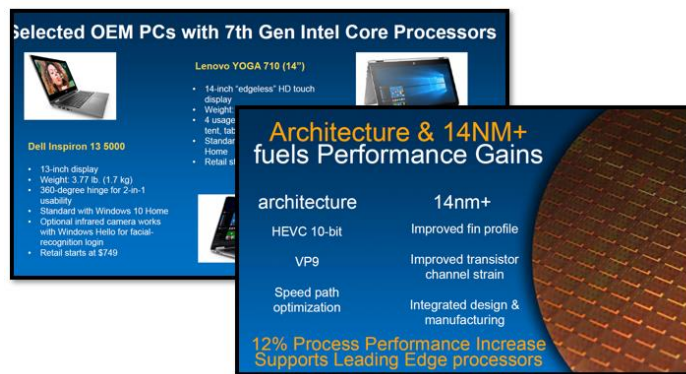

David Bradshaw, 7th Generation Intel Core Processor, INTEL PRESENTATION at 3 & 12 (2016).

178. On information and belief, one or more Dell subsidiaries and/or affiliates use the Dell ‘609 Products in regular business operations.

179. The functionality of the encoding process used by the Dell ‘609 Products uses “motion vector[s]: A two-dimensional vector used for *inter prediction* that provides an offset from the coordinates in the decoded picture to the coordinates in a reference picture,” as defined in definition 3.83 of the *ITU-T H.265 Series H: Audiovisual and Multimedia Systems* (2018) (emphasis added); *see also, e.g.*, Gary J. Sullivan, Jens-Rainer Ohm, Woo-Jin Han, and Thomas Wiegand, *Overview of the High Efficiency Video Coding (HEVC) Standard*, published in IEEE TRANSACTIONS ON CIRCUITS AND SYSTEMS FOR VIDEO TECHNOLOGY, Vol. 22, No. 12 at 1650 (December 2012) (“The encoding process for inter picture prediction consists of choosing motion data comprising the selected reference picture and motion vector (MV) to be applied for predicting the samples of each block. The encoder and decoder generate identical inter picture prediction signals by applying motion compensation (MC) using the MV and mode decision data.”).

180. The Dell ‘609 Products further select the selected image selection area based on a range of possible motion vectors in the selected image search area. Further, the search area of the selected image segment has a center. Specifically, the Dell ‘609 Products contain functionality for selecting a coding unit. The coding unit comprises a selected image segment. The below diagram shows that the Dell ‘609 Products select a content unit (e.g., selected image segment).

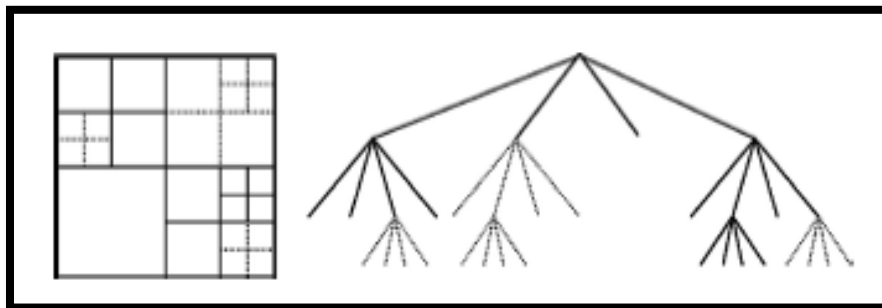

Gary J. Sullivan, Jens-Rainer Ohm, Woo-Jin Han, and Thomas Wiegand, Fellow, IEEE, *Overview of the High Efficiency Video Coding (HEVC) Standard*, published in IEEE TRANSACTIONS ON CIRCUITS AND SYSTEMS FOR VIDEO TECHNOLOGY, Vol. 22, No. 12 at 1656 (December 2012).

181. The Dell ‘609 Products enable the selection of a selected image segment of a given image corresponding to an image segment of a first video image. The selected image segment has a center and a search area is defined around the image segment. Specifically, the Dell ‘609 Products encode video data using inter-frame coding. Specifically, video data is encoded using a predecessor frame. Inter-prediction used in the encoding of video data allows a transform block to span across multiple prediction blocks for inter picture-predicted coding units to maximize the potential coding efficiency benefits of the quadtree-structured transform block partitioning.

The basic source-coding algorithm is a hybrid of interpicture prediction to exploit temporal statistical dependences, intrapicture prediction to exploit spatial statistical dependences, and transform coding of the prediction residual signals to further exploit spatial statistical dependences.

Gary J. Sullivan, Jens-Rainer Ohm, Woo-Jin Han, and Thomas Wiegand, Fellow, IEEE, *Overview of the High Efficiency Video Coding (HEVC) Standard*, published in IEEE TRANSACTIONS ON CIRCUITS AND SYSTEMS FOR VIDEO TECHNOLOGY, Vol. 22, No. 12 at 1652 (December 2012) (emphasis added).

182. The video data processed by the Dell ‘609 Products is encoded using inter-picture prediction that makes use of the temporal correlation between pictures to derive a motion-compensated prediction (MCP) for a block of image samples. For this block-based motion compensated prediction, a video picture is divided into rectangular blocks. Assuming homogeneous motion inside one block, and that moving objects are larger than one block, for each

block, a corresponding block in a previously decoded picture can be found that serves as a predictor. The general concept of inter-frame-based encoding using motion-compensated prediction based on a translational motion model is illustrated below.

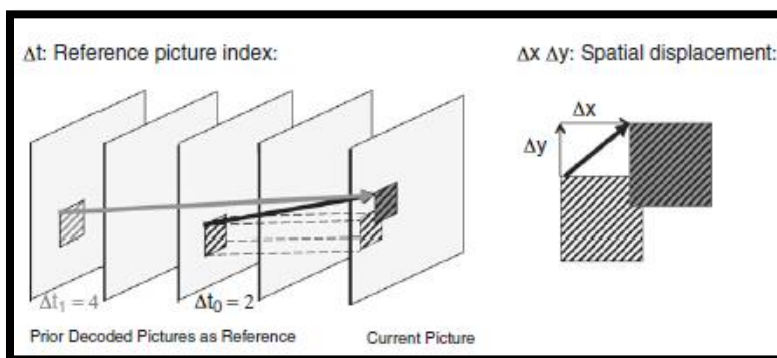

Benjamin Bross, *Inter-Picture Prediction In HEVC*, HIGH EFFICIENCY VIDEO CODING (HEVC) at 114 (September 2014).

183. The following excerpt from an article describing the architecture of the video stream encoded by the Dell ‘609 Products describes the functionality wherein the second encoded frame of the video data is dependent on the encoding of a first frame. “HEVC inter prediction uses motion vectors pointing to one reference frame . . . to predict a block of pixels.”

HEVC inter prediction uses motion vectors pointing to one reference frame (uni-prediction) or two reference frames (bi-prediction) to predict a block of pixels. The size of the predicted block, called Prediction Unit (PU), is determined by the Coding Unit (CU) size and its partitioning mode. For example, a 32×32 CU with $2N \times N$ partitioning is split into two PUs of size 32×16 , or a 16×16 CU with $nL \times 2N$ partitioning is split into 4×16 and 12×16 PUs.

Mehul Tikekar, *et al.*, *Decoder Hardware Architecture for HEVC*, HIGH EFFICIENCY VIDEO CODING (HEVC) (September 2014).

184. The Dell ‘609 Products comprise a system for retrieving image motion data related to the search area. Specifically, the Dell ‘609 Products retrieve data relating to the motion search area. The data, which includes the motion vector index, is sent from the encoder and retrieved by the decoder.

Since inter-picture prediction typically compensates for the motion of real-world objects between pictures of a video sequence, it is also referred to as motion-compensated prediction. While intra-picture prediction exploits the spatial redundancy between neighboring blocks inside a picture, motion-compensated prediction utilizes the large amount of temporal redundancy between pictures. In either case, the resulting prediction error, which is formed by taking the difference between the original block and its prediction, is transmitted using transform coding, which exploits the spatial redundancy inside a block and consists of a decorrelating linear transform, scalar quantization of the transform coefficients and entropy coding of the resulting transform coefficient levels.

Heiko Schwarz, Thomas Schierl, Detlev Marpe, *Block Structures and Parallelism Features in HEVC*, in HEVC, HIGH EFFICIENCY VIDEO CODING (HEVC) at 49 (September 2014) (emphasis added).

For each CU, a prediction mode is signaled inside the bitstream. The prediction mode indicates whether the CU is coded using intra-picture prediction or motion-compensated prediction. If intra-picture prediction is chosen, one of the 35 supported spatial intra prediction modes has to be selected for the luma CB and signaled inside the bitstream. If the CU has the minimum CU size specified in the sequence parameter set, the luma CB can also be decomposed into four equallysized square subblocks, in which case a separate intra prediction mode is transmitted for each of these subblocks.

Id. at 59 (emphasis added).

185. Further, the Dell ‘609 Products contain functionality wherein the motion vector prediction performed includes the ability to transmit in the bitstream the candidate index of motion vectors. Documentation of the encoding process states that the encoder will “pick up the MV [motion vector] to use as an estimator using the index sent by the encoder in the bitstream.”

Inter prediction

For motion vector prediction HEVC has two reference lists: L0 and L1. They can hold 16 references each, but the maximum total number of unique pictures is 8. Multiple instances of the same ref frame can be stored with different weights. HEVC motion estimation is much more complex than in AVC. It uses list indexing. There are two main prediction modes: Merge and Advanced MV. Each PU can use one of those methods and can have forward (a MV) or bi-directional prediction (2 MV). In Advanced MV mode a list of candidates MV is created (spatial and temporal candidates picked with a complex, probabilistic logic), when the list is created only the best candidate index is transmitted in the bitstream plus the MV delta (the difference between the real MV and the prediction). On the other side, the decoder will build and update continuously the same candidate list using the exact same rules used by the encoder and will pick-up the MV to use as estimator using the index sent by the encoder in the bitstream. The merge mode is similar, the main difference is that the candidates' list is calculated from neighboring MV and is not added to a delta MV. It is the equivalent of "skip" mode in AVC.

Fabio Sonnati, *H265 – Part I: Technical Overview*, VIDEO ENCODING & STREAMING TECHNOLOGIES WEBSITE (June 20, 2014) (emphasis added).

186. The Dell ‘609 Products comprise a system for specifying that the center of the search area is offset from the center of the image section. Specifically, the Dell ‘609 Products, when selecting a temporal candidate for HEVC encoding, default to the right bottom position just outside of the collocated prediction unit.

It can be seen from Fig. 5.4b that only motion vectors from spatial neighboring blocks to the left and above the current block are considered as spatial MVP candidates. This can be explained by the fact that the blocks to the right and below the current block are not yet decoded and hence, their motion data is not available. Since the co-located picture is a reference picture which is already decoded, it is possible to also consider motion data from the block at the same position, from blocks to the right of the co-located block or from the blocks below. In HEVC, the block to the bottom right and at the center of the current block have been determined to be the most suitable to provide a good temporal motion vector predictor (TMVP).

Benjamin Bross, *et al.*, *Inter-picture prediction in HEVC*, in HIGH EFFICIENCY VIDEO CODING (HEVC) at 119 (2014) (emphasis added).

187. Descriptions of the HEVC encoding process, which are implemented by the Dell ‘609 Products state “for the temporal candidate, the right bottom position just outside of the collocated PU of the reference picture is used if it is available. Otherwise, the center position is used instead.” Gary J. Sullivan, Jens-Rainer Ohm, Woo-Jin Han, and Thomas Wiegand, Fellow, IEEE, *Overview of the High Efficiency Video Coding (HEVC) Standard*, published in IEEE TRANSACTIONS ON CIRCUITS AND SYSTEMS FOR VIDEO TECHNOLOGY, Vol. 22, No. 12 at 1660 (December 2012) (emphasis added).

188. The Dell ‘609 Products encode video data such that a predetermined search area (S) center is offset from the center of the image segment. The predetermined search area is called a partition and there are eight different partition modes in the H.265 standard, these partition modes are shown in the figure below. The last four partition modes are asymmetric, meaning their center is offset from the overall CU center.

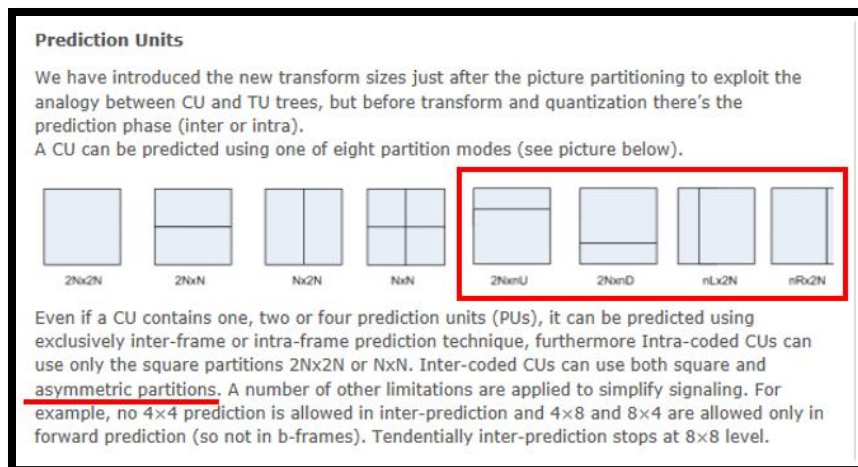

Fabio Sonati, *H265 – Part I: Technical Overview*, VIDEO ENCODING & STREAMING TECHNOLOGIES WEBSITE (June 20, 2014) (emphasis added).

189. The figure below shows the syntax as well as the instructions for enabling the asymmetric partitions within the H.265 standard as implemented by the Dell ‘609 Products.

max_transform_hierarchy_depth_intra specifies the maximum hierarchy depth for transform units of coding units coded in intra prediction mode. The value of max_transform_hierarchy_depth_intra shall be in the range of 0 to CtbLog2SizeY – MinTbLog2SizeY, inclusive.

scaling_list_enabled_flag equal to 1 specifies that a scaling list is used for the scaling process for transform coefficients. scaling_list_enabled_flag equal to 0 specifies that scaling list is not used for the scaling process for transform coefficients.

sps_scaling_list_data_present_flag equal to 1 specifies that the scaling_list_data() syntax structure is present in the SPS. sps_scaling_list_data_present_flag equal to 0 specifies that the scaling_list_data() syntax structure is not present in the SPS. When not present, the value of sps_scaling_list_data_present_flag is inferred to be equal to 0.

amp_enabled_flag equal to 1 specifies that asymmetric motion partitions, i.e., PartMode equal to PART_2NxU, PART_2NxD, PART_nLx2N or PART_nRx2N, may be used in coding tree blocks. amp_enabled_flag equal to 0 specifies that asymmetric motion partitions cannot be used in coding tree blocks.

sample_adaptive_offset_enabled_flag equal to 1 specifies that the sample adaptive offset process is applied to the reconstructed picture after the deblocking filter process. sample_adaptive_offset_enabled_flag equal to 0 specifies that the sample adaptive offset process is not applied to the reconstructed picture after the deblocking filter process.

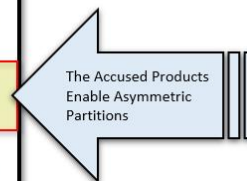

High Efficiency Video Coding, SERIES H: AUDIOVISUAL AND MULTIMEDIA SYSTEMS: INFRASTRUCTURE OF AUDIOVISUAL SERVICES – CODING OF MOVING VIDEO REC. ITU-T H.265 at 76 (February 2018) (annotation added).

190. On information and belief, one or more of the Dell ‘609 Products include technology for compensation and estimation of motion in video images.

191. On information and belief, by complying with the HEVC standard, the Dell devices – such as the Dell ‘609 Products – necessarily infringe the ‘609 patent. The mandatory sections of the HEVC standard require the elements required by certain claims of the ‘609 patent, including but not limited to claim 1 of the ‘609 patent. *High Efficiency Video Coding, SERIES H:*

AUDIOVISUAL AND Multimedia SYSTEMS: INFRASTRUCTURE OF AUDIOVISUAL SERVICES – CODING OF MOVING VIDEO REC. ITU-T H.265 (February 2018) (The following sections of the HEVC Standard are relevant to Dell’s infringement of the ‘609 patent: “8.3.2 Decoding process for reference picture set;” “8.5.4 Decoding process for the residual signal of coding units coded in inter prediction mode;” “8.6 Scaling, transformation and array construction process prior to deblocking filter process;” “8.5.2 Inter prediction process;” “8.5.3 Decoding process for prediction units in inter prediction mode;” and “8.7.2 Deblocking filter process;” “8.7.3 Sample adaptive offset process.”).

192. On information and belief, the Dell ‘609 Products comply with the HEVC standard, which requires estimating and/or compensating motion in video images.

193. On information and belief, Dell has directly infringed and continues to directly infringe the ‘609 patent by, among other things, making, using, offering for sale, and/or selling technology for compensation and estimation of motion in video images, including but not limited to the Dell ‘609 Products.

194. On information and belief, one or more of the Dell ‘609 Products improve video signal processing functionality used in motion compensated prediction in encoding and compressing of digital video signals, motion compensated filtering in noise reduction, motion compensated interpolation in video format conversion, and motion compensated de-interlacing of interlaced video signals, among other video processing functionalities.

195. On information and belief, one or more of the Dell ‘609 Products enable a method of estimating or compensating motion in video images that includes using a video processor to select an image segment of a given video image.

196. On information and belief, one or more of the Dell '609 Products enable a method of estimating or compensating motion in video images that includes using the video processor to define an asymmetric search area surrounding the image segment based on ranges of possible motion vectors for the image segment.

197. On information and belief, one or more of the Dell '609 Products enable a method of estimating or compensating motion in video images that includes using the video processor to retrieve image data related to the asymmetric search area.

198. On information and belief, one or more of the Dell '609 Products enable a method of estimating or compensating motion in video images that includes a video processor that defines the asymmetric search area to have a center offset from a center of the image segment, the offset thereby defining asymmetry of the asymmetric search area, and statistically determines from an average vector of motion vectors established for one or more previous images.

199. On information and belief, the Dell '609 Products are available to businesses and individuals throughout the United States.

200. On information and belief, the Dell '609 Products are provided to businesses and individuals located in the Southern District of New York.

201. By making, using, testing, offering for sale, and/or selling products and services for compensation and estimation of motion in video images, including but not limited to the Dell '609 Products, Dell has injured Dynamic Data and is liable to the Plaintiff for directly infringing one or more claims of the '609 patent, including at least claim 1 pursuant to 35 U.S.C. § 271(a).

202. On information and belief, Dell also indirectly infringes the '609 patent by actively inducing infringement under 35 U.S.C. § 271(b).

203. Dell has had knowledge of the '609 patent since at least service of this First Amended Complaint or shortly thereafter, and on information and belief, Dell knew of the '609 patent and knew of its infringement, including by way of this lawsuit.

204. On information and belief, Dell intended to induce patent infringement by third-party customers and users of the Dell '609 Products and had knowledge that the inducing acts would cause infringement or was willfully blind to the possibility that its inducing acts would cause infringement. Dell specifically intended and was aware that the normal and customary use of the accused products would infringe the '609 patent. Dell performed the acts that constitute induced infringement, and would induce actual infringement, with knowledge of the '609 patent and with the knowledge that the induced acts would constitute infringement. For example, Dell provides the Dell '609 Products that have the capability of operating in a manner that infringe one or more of the claims of the '609 patent, including at least claim 1, and Dell further provides documentation and training materials that cause customers and end users of the Dell '609 Products to utilize the products in a manner that directly infringe one or more claims of the '609 patent.⁷² By providing instruction and training to customers and end-users on how to use the Dell '609 Products in a manner that directly infringes one or more claims of the '609 patent, including at least claim 1, Dell specifically intended to induce infringement of the '609 patent. On information and belief, Dell engaged in such inducement to promote the sales of the Dell '609 Products, e.g., through Dell user manuals, product support, marketing materials, and training materials to actively induce the users of the accused products to infringe the '609 patent. Accordingly, Dell has induced

⁷² See, e.g., *Dell G7 15*, SETUP AND SPECIFICATIONS (2018); *Alienware Graphics Amplifier*, USER'S GUIDE (2014); *Alienware Aurora R8*, SETUP AND SPECIFICATIONS (2018); *Inspiron 15 7000 Gaming*, SERVICE MANUAL (2017-2018); *XPS 13*, SETUP AND SPECIFICATIONS (2017); *Dell Latitude 5420/E5420/E5420m*, OWNER'S MANUAL (2011); *Alienware M17x R4*, OWNER'S MANUAL (2012); *Dell Vostro 15-3558*, OWNER'S MANUAL (2015).

and continues to induce users of the accused products to use the accused products in their ordinary and customary way to infringe the '609 patent, knowing that such use constitutes infringement of the '609 patent.

205. The '609 patent is well-known within the industry as demonstrated by multiple citations to the '609 patent in published patents and patent applications assigned to technology companies and academic institutions. Dell is utilizing the technology claimed in the '609 patent without paying a reasonable royalty. Dell is infringing the '609 patent in a manner best described as willful, wanton, malicious, in bad faith, deliberate, consciously wrongful, flagrant, or characteristic of a pirate.

206. To the extent applicable, the requirements of 35 U.S.C. § 287(a) have been met with respect to the '609 patent.

207. As a result of Dell's infringement of the '609 patent, Dynamic Data has suffered monetary damages, and seeks recovery in an amount adequate to compensate for Dell's infringement, but in no event less than a reasonable royalty for the use made of the invention by Dell together with interest and costs as fixed by the Court.

COUNT III
INFRINGEMENT OF U.S. PATENT NO. 8,135,073

208. Dynamic Data references and incorporates by reference the preceding paragraphs of this Complaint as if fully set forth herein.

209. Dell designs, makes, uses, sells, and/or offers for sale in the United States products and/or services for enhancing subsequent images of a video stream in which frames are encoded based on previous frames using prediction and motion estimation.

210. Dell designs, makes, sells, offers to sell, imports, and/or uses Dell devices that contain H.265 decoding functionality, including but not limited to Dell desktops, laptops, projectors, and all-in-one devices, including the following exemplary models: Dell G3 3579, Dell G3 3779, Dell G5 15 5587, Dell G7 15 7588, Inspiron 14 Gaming 7466, Inspiron 14 Gaming 7467, Inspiron 15 Gaming 7566, Inspiron 15 Gaming 7567, Inspiron 15 Gaming 7577, Inspiron 5457, Inspiron 5458, Inspiron 5557, Inspiron 5558, Inspiron 5587, Inspiron 5758, Inspiron 7447, Inspiron 7460, Inspiron 7466, Inspiron 7472, Inspiron 7557, Inspiron 7559, Inspiron 7560, Inspiron 7566, Inspiron 7572, Inspiron 7588, Inspiron Desktop 3470, Inspiron Desktop 3670, Inspiron Desktop 5676, Inspiron Desktop 5680, Latitude 3190, Latitude 3190 2-in-1, Latitude 5420, Latitude 5424, Latitude 5491, Latitude 5591, Latitude 7424, Optiplex 3060, Optiplex 5060, Optiplex 5260 AIO, Optiplex 7060, Optiplex 7460 AIO, Optiplex 7760 AIO, Optiplex XE3, Precision 3430, Precision 3430 XL Tower, Precision 3530, Precision 3630, Precision 3630 XL Tower, Precision 3930 Rack, Precision 3930 XL RACK, Precision 5510, Precision 5520, Precision 5530, Precision 7530, Precision 7730, Precision M3800, Vostro Desktop 3470, Vostro Desktop 3670, Vostro Notebook 3458, Vostro Notebook 3558, Vostro Notebook 5459, Vostro Notebook 5468, Vostro Notebook 5480, Vostro Notebook 5568, Vostro Notebook 7580, XPS 13 9360, XPS 13 9365 2-in-1, XPS 13 9370, XPS 15 9550, XPS 15 9560, XPS 15 9570, XPS 15 9575 2-in-1, XPS Desktop XPS 8930, XPS Notebook 9365, XPS Notebook 9530, XPS Notebook 9550, XPS Notebook 9560, XPS Notebook 9570, Dell Advanced Projector S718QL, Alienware 15, Alienware 15 R2-R4, Alienware 17, Alienware 17 R2-R5, Alienware 18, Alienware Area 51, Alienware Area-51 ALX, Alienware Area-51 R2-R5 & R7, Alienware Area-51 Threadripper Edition R3 & R6 & R7, Alienware Aurora, Alienware Aurora ALX, Alienware Aurora R2-R8, Alienware m15,

Alienware M15x, Alienware M17x, Alienware M17x R2-R4, Alienware M18x, Alienware M18x R2, Alienware X51, and Alienware X51 R2 & R3 (collectively, the “Dell ‘073 Product(s)”).

211. The Dell ‘073 Products perform video processing compliant with the HEVC standard. See e.g., *Dell Desktop Support*, DELL SUPPORT WEBSITE, available at: <https://www.dell.com/support/home/us/en/19/products/desktop>; *Dell Laptop Support*, DELL SUPPORT WEBSITE, available at: <https://www.dell.com/support/home/us/en/19/products/laptop>

212. The below table shows Dell ‘073 Products that contain the infringing HEVC compliant video processing technology.

Exemplar Dell Models	Graphics Processing Unit (GPU)	HEVC Decode/Encode ⁷³
Dell G3 3579	NVIDIA GeForce GTX 1050 Ti ⁷⁴	Yes
Dell G3 3779	NVIDIA GeForce GTX 1060 w/ Max Q ⁷⁵	Yes
Dell G5 15 5587	NVIDIA GeForce GTX 1060 w/ Max Q ⁷⁶	Yes
Dell G7 15 7588	NVIDIA GeForce GTX 1060 w/ Max Q ⁷⁷	Yes
Inspiron 14 Gaming 7466	Intel HD Graphics 530 ⁷⁸	Yes
Inspiron 14 Gaming 7467	Intel HD Graphics 630 ⁷⁹	Yes
Inspiron 15 Gaming 7566	Intel HD Graphics 530 (Integrated) / NVIDIA GeForce GTX630M (Discrete) ⁸⁰	Yes

⁷³ *NVIDIA Video Encode And Decode GPU Support Matrix*, NVIDIA DEVELOPER WEBSITE, available at: <https://developer.nvidia.com/video-encode-decode-gpu-support-matrix> (showing support for HEVC in NVIDIA Graphics cards); *Intel Product Matrix*, INTEL WEBSITE, available at: <https://www.intel.com/content/www/us/en/products> (showing HEVC Support); *Intel Graphics Product Specifications*, INTEL WEBSITE, available at: <https://www.intel.com/content/www/us/en/architecture-and-technology/visual-technology/graphics-overview.html>.

⁷⁴ *Dell Model G3 3579*, DELL WEBSITE, available at: <https://www.dell.com/en-us/work/shop/dell-laptops-and-notebooks/dell-g3-15-gaming-laptop/spd/g-series-15-3579-laptop>.

⁷⁵ *Dell Model G3 3779*, DELL WEBSITE, available at: <https://www.dell.com/en-us/shop/dell-laptops/dell-g3-17-gaming/spd/g-series-17-3779-laptop>.

⁷⁶ *Dell Model G5 15 5587*, DELL WEBSITE, available at: <https://www.dell.com/en-us/shop/dell-laptops/dell-g5-15-gaming/spd/g-series-15-5587-laptop>.

⁷⁷ *Dell Model G7 15 7588*, DELL WEBSITE, available at: <https://www.dell.com/en-us/shop/dell-laptops/dell-g7-15-gaming/spd/g-series-15-7588-laptop>.

⁷⁸ *Dell Inspiron 14 Gaming Setup and Specifications*, DELL MANUAL MODEL NO. INSPIRON 14-7466 at 18 (2016).

⁷⁹ *Dell Inspiron 14 7000 Gaming Series Setup and Specifications*, DELL SPECIFICATIONS MODEL NO. INSPIRON 14-7467 at 18 (2016).

⁸⁰ *Dell Inspiron 15 Gaming Setup and Specifications*, DELL MANUAL MODEL NO. 15-7566 at 18 (2016).

Inspiron 15 Gaming 7567	NVIDIA GeForce GTX 1050Ti with 4GB GDDR5 / NVIDIA GeForce GTX 1050 with 4GB GDDR5 ⁸¹	Yes
Inspiron 15 Gaming 7577	Intel HD Graphics 630 (Integrated) / NVIDIA GeForce GTX 1050/ GTX 1050 Ti/ GTX 1060 Max-Q (Discrete) ⁸²	Yes
Inspiron 5457	Intel HD Graphics 520 (integrated) / NVIDIA GeForce 930M (Discrete) ⁸³	Yes
Inspiron 5458	Intel HD Graphics 4400/4500 (integrated) / NVIDIA GeForce 920M (discrete) ⁸⁴	Yes
Inspiron 5557	Intel HD Graphics 520 (integrated) / NVIDIA GeForce 930M (discrete) ⁸⁵	Yes
Inspiron 5558	Intel HD Graphics 4400/4500 (integrated) / NVIDIA GeForce 920M (discrete) ⁸⁶	Yes
Inspiron 5587	NVIDIA GeForce GTX 1060 Max-Q ⁸⁷	Yes
Inspiron 5758	Intel HD Graphics 4400/4500 (integrated) / NVIDIA GeForce 920M (discrete) ⁸⁸	Yes
Inspiron 7447	Intel Iris Pro Graphic 5200 (integrated) / NVIDIA GeForce GTX 850M (discrete) ⁸⁹	Yes
Inspiron 7460	Intel HD Graphics 610/620/635 (integrated)/ NVIDIA GeForce 940M ⁹⁰	Yes
Inspiron 7466	Intel HD Graphics 530 (integrated) / NVIDIA GeForce GTX 950M ⁹¹	Yes
Alienware Area 51	NVIDIA GeForce RTX 2080 Ti OC with 11GB GDDR6 ⁹²	Yes
Alienware Area-51 R2	NVIDIA® GeForce GTX ⁹³	Yes
Alienware Area-51 R4/R5	NVIDIA® GeForce GTX ⁹⁴	Yes

⁸¹ *Dell Inspiron Model 7567*, DELL WEBSITE, available at: <https://www.dell.com/us/dfh/p/inspiron-15-7567-laptop/pd>

⁸² *Dell Inspiron 15 7000 Gaming Setup and Specifications*, DELL MANUAL MODEL NO. INSPIRON 15-7577 at 23 (2018).

⁸³ *Dell Inspiron 14 5000 Series Specification*, DELL SPECIFICATIONS MODEL NO. INSPIRON 14-5457 at 12 (2015).

⁸⁴ *Dell Inspiron 14 5000 Series Specification*, DELL SPECIFICATIONS MODEL NO. INSPIRON 14-5458 at 12 (2015).

⁸⁵ *Dell Inspiron 14 5000 Series Specification*, DELL SPECIFICATIONS MODEL NO. INSPIRON 14-5557 at 12 (2015).

⁸⁶ *Dell Inspiron 14 5000 Series Specification*, DELL SPECIFICATIONS MODEL NO. INSPIRON 14-5558 at 12 (2015).

⁸⁷ *Dell Inspiron Model 5587*, DELL WEBSITE, available at: <https://www.dell.com/en-us/shop/dell-laptops/dell-g5-15-gaming/spd/g-series-15-5587-laptop>

⁸⁸ *Dell Inspiron 17 5000 Series Specification*, DELL SPECIFICATIONS MODEL NO. INSPIRON 17-5758 at 12 (2015).

⁸⁹ *Dell Inspiron 14 7000 Series Specification*, DELL SPECIFICATIONS MODEL NO. INSPIRON 7447 at 12 (2014).

⁹⁰ *Dell Inspiron 14 7000 Setup and Specification*, DELL MANUAL MODEL NO. INSPIRON 14-7460 at 18 (2018)

⁹¹ *Dell Inspiron 14 Gaming Setup and Specifications*, DELL MANUAL MODEL NO. INSPIRON 14-7466 at 18 (2016).

⁹² *Dell Alienware Specifications*, DELL WEBSITE, available at: <https://www.dell.com/en-us/shop/dell-desktop-computers/alienware-area-51/spd/alienware-area51-r5>

⁹³ *Dell Alienware Specifications*, DELL WEBSITE, available at: <https://www.dell.com/en-us/shop/cty/pdp/spd/alienware-area51-r2>

⁹⁴ *Dell Alienware Specifications*, DELL WEBSITE, available at: <https://www.dell.com/en-us/shop/dell-desktop-computers/alienware-area-51-gaming-desktop/spd/alienware-area51-r4>

Alienware Area-51 Threadripper R3/R6	NVIDIA GeForce GTX 1080 ⁹⁵	Yes
Alienware Area-51 Threadripper Edition R7	Dual NVIDIA® GeForce® RTX 2080 Ti OC ⁹⁶	Yes
Alienware Aurora	NVIDIA® GeForce® RTX 2080 Ti OC with 11GB GDDR6 ⁹⁷	Yes

213. Dell documentation states that the Dell ‘073 Products are compliant with the HEVC standard as shown in the following excerpts.

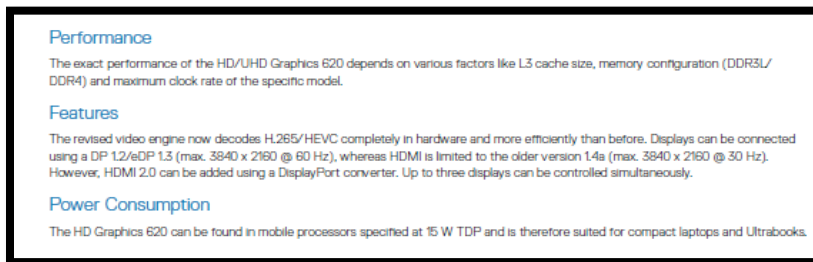

DELL LATITUDE 5420 RUGGED OWNER’S MANUAL at 44 (2015) (“The revised video engine now decodes H.265/HEVC completely in hardware and more efficiently than before.”).

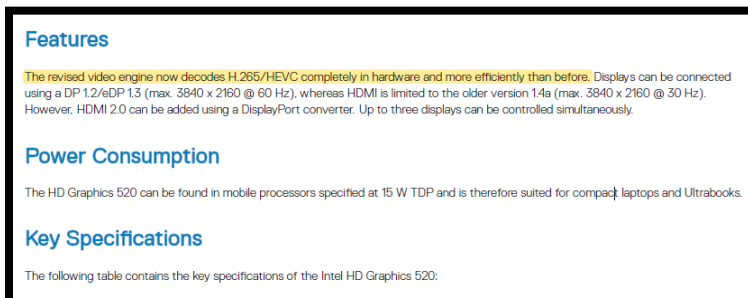

DELL VOSTRO 14-3468 OWNER’S MANUAL at 55 (2018) (annotation added) (“The revised video engine now decodes H.265/HEVC completely in hardware and more efficiently than before.”).

⁹⁵ Dell Alienware Specifications, DELL WEBSITE, available at: <https://www.dell.com/en-us/shop/dell-desktop-computers/alienware-area-51-threadripper-edition/spd/alienware-area51-r6>

⁹⁶ Dell Alienware Specifications, DELL WEBSITE, available at: <https://www.dell.com/en-us/shop/desktops/area-51-threadripper/spd/alienware-area51-r7>

⁹⁷ Dell Alienware Specifications, DELL WEBSITE, available at: <https://www.dell.com/en-us/shop/dell-desktop-computers/alienware-aurora/spd/alienware-aurora-r7-desktop>



DELL PRODUCT QUICK REFERENCE MATRIX Q4 2018 at 17 (2018) (“New HEVC 10-bit and VP9 decode”).

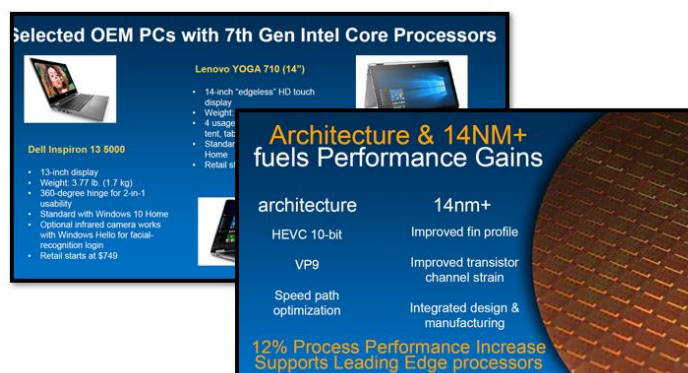

David Bradshaw, *7th Generation Intel Core Processor*, INTEL PRESENTATION at 3 & 12 (2016).

214. On information and belief, the Dell ‘073 Products contain a processor for decoding the received encoded frame-based encoded video data. Further, the Dell ‘073 Products apply a remapping policy to the first frame of decoded video data using a region-based luma analysis. As part of the decoding process performed by Dell ‘073 Products, a reference picture (first frame) is decoded and two in-loop filters (deblocking and a sample adaptive offset) are applied to the reference picture.

215. On information and belief, the Dell ‘073 Products comprise a video decoder for decoding video images. Specifically, the Dell ‘073 Products contain functionality for video decoding through H.265/High Efficiency Video Coding (“HEVC”) decoding.

216. On information and belief, the Dell ‘073 Products contain a processor for decoding the received encoded frame-based encoded video data. Further, the Dell ‘073 Products apply a remapping policy to the first frame of decoded video data using a region-based luma analysis. As

part of the decoding process performed by Dell '073 Products, a reference picture (first frame) is decoded and two in-loop filters (deblocking and a sample adaptive offset) are applied to the reference picture.

217. The Dell '073 Products have an input for receiving frame-based encoded video information. Specifically, the Dell '073 Products receive frame-based encoded video information in the form of video data that is encoded in the High

218. On information and belief, the Dell '073 Products include inputs for receiving and decoding HEVC video data

219. On information and belief, the Dell '073 Products incorporate a decoding unit for decoding the frame of the received video data. The encoding and decoding process for video data received by the Dell '073 Products use inter-picture prediction wherein motion data comprises the selection of a reference frame and motion vectors to be applied in predicting the samples of each block.

220. On information and belief, one or more of the Dell '073 Products include technology for enhancing subsequent images of a video stream in which frames are encoded based on previous frames using prediction and motion estimation.

221. On information and belief, by complying with the HEVC standard, the Dell devices – such as the Dell '073 Products – necessarily infringe the '073 patent. The mandatory sections of the HEVC standard require the elements required by certain claims of the '073 patent, including but not limited to claim 14 of the '073 patent. *High Efficiency Video Coding, SERIES H: AUDIOVISUAL AND Multimedia SYSTEMS: INFRASTRUCTURE OF AUDIOVISUAL SERVICES – CODING OF MOVING VIDEO REC. ITU-T H.265* (February 2018) (The following sections of the HEVC Standard are relevant to Dell's infringement of the '073 patent: “8.3.2 Decoding process for

reference picture set;” “8.5.4 Decoding process for the residual signal of coding units coded in inter prediction mode;” “8.6 Scaling, transformation and array construction process prior to deblocking filter process;” “8.5.2 Inter prediction process;” “8.5.3 Decoding process for prediction units in inter prediction mode;” and “8.7.2 Deblocking filter process;” “8.7.3 Sample adaptive offset process.”).

222. On information and belief, the Dell ‘073 Products comply with the HEVC standard, which requires that motion vectors are recovered from the second frame in the video stream.

The decoding process for prediction units in inter prediction mode consists of the following ordered steps:

1. The derivation process for motion vector components and reference indices as specified in clause 8.5.3.2 is invoked with the luma coding block location (x_{Cb} , y_{Cb}), the luma prediction block location (x_{Bl} , y_{Bl}), the luma coding block size block n_{CbS} , the luma prediction block width n_{PbW} , the luma prediction block height n_{PbH} and the prediction unit index $partIdx$ as inputs, and the luma motion vectors $mvL0$ and $mvL1$, when $ChromaArrayType$ is not equal to 0, the chroma motion vectors $mvCL0$ and $mvCL1$, the reference indices $refIdxL0$ and $refIdxL1$ and the prediction list utilization flags $predFlagL0$ and $predFlagL1$ as outputs.

High Efficiency Video Coding, SERIES H: AUDIOVISUAL AND MULTIMEDIA SYSTEMS: INFRASTRUCTURE OF AUDIOVISUAL SERVICES – CODING OF MOVING VIDEO REC. ITU-T H.265 at § 8.5.3.1 (February 2018).

223. On information and belief, Dell has directly infringed and continues to directly infringe the ‘073 patent by, among other things, making, using, offering for sale, and/or selling technology for enhancing subsequent images of a video stream in which frames are encoded based on previous frames using prediction and motion estimation, including but not limited to the Dell ‘073 Products. The following excerpt explains how HEVC is a form of frame-based encoded video information.

One way of achieving high video compression is to predict pixel values for a frame based on prior and succeeding pictures in the video. Like its predecessors, H.265 features the ability to predict pixel values between pictures, and in particular, to specify in which order pictures are coded and which pictures are predicted from which. The coding order is specified for Groups Of Pictures (GOP), where a number of pictures are grouped together and predicted from each other in a

specified order. The pictures available to predict from, called reference pictures, are specified for every individual picture.

Johan Bartelmeß. *Compression Efficiency of Different Picture Coding Structures in High Efficiency Video Coding (HEVC)*, UPTEC STS 16006 at 4 (March 2016) (emphasis added).

224. On information and belief, the Dell ‘073 Products receive encoded video data that is encoded using inter-frame coding. Specifically, the encoded video stream received by the Dell ‘073 Products is coded using its predecessor frame. Inter-prediction used in the encoded video data received by the Dell ‘073 Products allows a transform block to span across multiple prediction blocks for inter-picture predicted coding units to maximize the potential coding efficiency benefits of the quadtree-structured transform block partitioning.

The basic source-coding algorithm is a hybrid of interpicture prediction to exploit temporal statistical dependences, intrapicture prediction to exploit spatial statistical dependences, and transform coding of the prediction residual signals to further exploit spatial statistical dependences.

G. J. Sullivan, J.-R. Ohm, W.-J. Han, and T. Wiegand, *Overview of the High Efficiency Video Coding (HEVC) standard*, IEEE TRANS. CIRCUITS SYST. VIDEO TECHNOL., vol. 22, no. 12, p. 1654 (December 2012) (emphasis added).

225. The encoded video stream received by the Dell ‘073 Products is encoded using inter-picture prediction that makes use of the temporal correlation between pictures to derive a motion-compensated prediction (MCP) for a block of image samples. For this block-based motion compensated prediction, a video picture is divided into rectangular blocks. Assuming homogeneous motion inside one block, and that moving objects are larger than one block, for each block, a corresponding block in a previously decoded picture can be found that serves as a predictor. The general concept of inter-frame-based encoding using motion-compensated prediction based on a translational motion model is illustrated below.

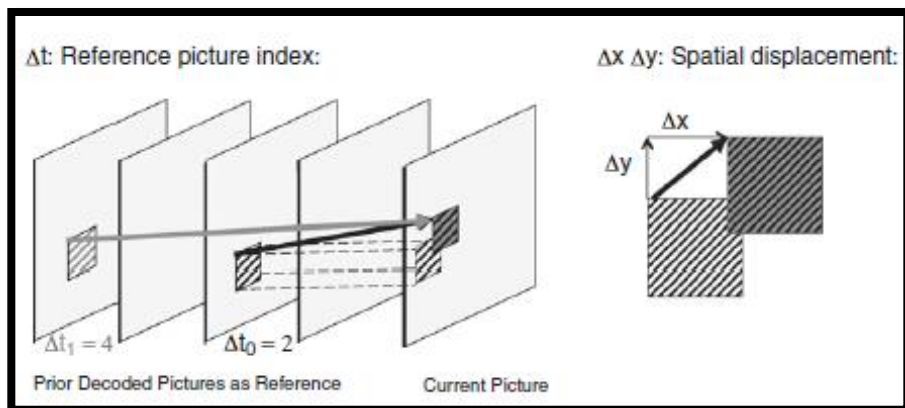

Benjamin Bross, *Inter-Picture Prediction In HEVC*, HIGH EFFICIENCY VIDEO CODING (HEVC) at 114 (September 2014).

226. The following excerpt from an article describing the architecture of the encoded video stream received by the Dell '073 Products describes the functionality wherein the second encoded frame of the video data is dependent on the encoding of a first frame. "HEVC inter prediction uses motion vectors pointing to one reference frame . . . to predict a block of pixels."

HEVC inter prediction uses motion vectors pointing to one reference frame (uni-prediction) or two reference frames (bi-prediction) to predict a block of pixels. The size of the predicted block, called Prediction Unit (PU), is determined by the Coding Unit (CU) size and its partitioning mode. For example, a 32×32 CU with $2N \times N$ partitioning is split into two PUs of size 32×16 , or a 16×16 CU with $nL \times 2N$ partitioning is split into 4×16 and 12×16 PUs.

Mehul Tikekar, *et al.*, *Decoder Hardware Architecture for HEVC*, HIGH EFFICIENCY VIDEO CODING (HEVC) (September 2014).

227. The following diagram shows how the Dell Products receive video data encoded using inter-frame prediction. Specifically, interframe prediction generates a motion vector based on the motion estimation across a first and second frame.

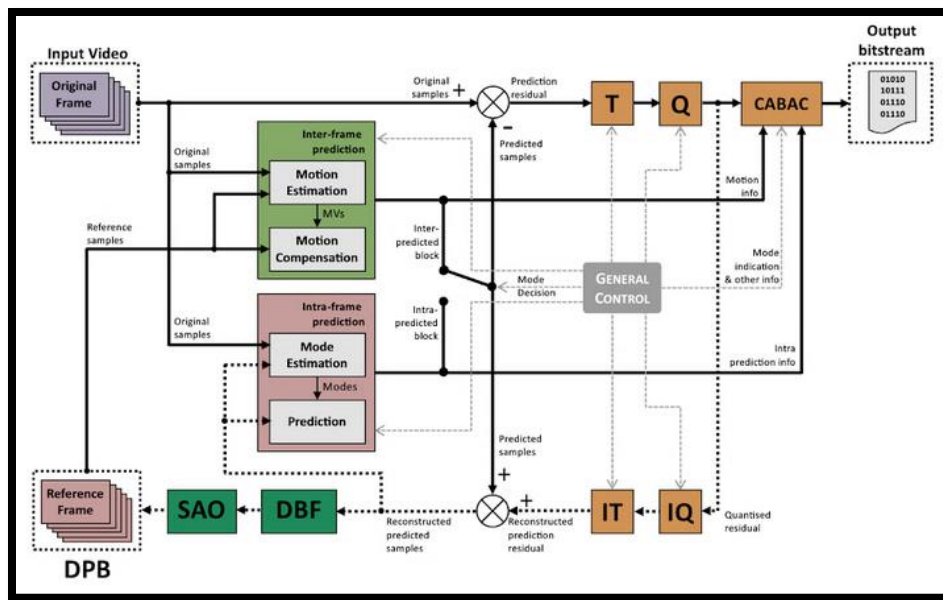

Guilherme Corrêa, *et al.*, COMPLEXITY-AWARE HIGH EFFICIENCY VIDEO CODING at 16 (2015).

228. On information and belief, one or more of the Dell ‘073 Products reduce the processing capacity required for providing video enhancements to video processing through re-mapping of previous frames for subsequent frames.

So, this reduces guessing with frame dropping. Let's go over what we've learned. So, with HEVC hierarchical encoding, we have improved temporal scalability. There's a much more obvious frame dropping pattern and it removes frame drop guessing during playback. We also have improved motion compensation, the reference frames are much closer to each other, so we can use more parts of other frames and it also improves compression.

Erik Turnquist and Brad Ford, *Working with HEIF and HEVC*, DELL WORLDWIDE DEVELOPER CONFERENCE 2017: SESSION 511 Transcript (2017) (emphasis added), *available at*: <https://developer.Dell.com/videos/play/wwdc2017/511>.

229. On information and belief, any implementation of the HEVC standard would infringe the ‘073 patent as every possible implementation of the standard requires: receiving a video stream containing encoded frame based video information (including both an encoded first frame and an encoded second frame); the encoded second frame that is received depends on the encoding of the first frame, the encoding of the second frame includes motion vectors indicating differences in positions between regions of the second frame and corresponding regions of the first

frame; the motion vectors define correspondence between regions of the second frame and corresponding regions of the first frame; decoding the video stream by recovering the motion vectors in the second stream; and determining a re-mapping strategy for the video enhancement of the decoded first frame using a region-based analysis where the first frame is remapped using a remapping strategy and at least one region of the second frame is remapped depending on the re-mapping strategy for corresponding regions of the first frame.

230. On information and belief, the Dell ‘073 Products use of sample adaptive offset is a region-based luma analysis that is applied to the decoded first frame (reference picture). “The SAO reduces sample distortion by first classifying the samples in the region into multiple categories with as selected classifier and adding a specific offset to each sample depending on its category. The classifier index and the offsets for each region are signaled in the bitstream.” Andrey Norkin, Chih-Ming Fu, Yu-Wen Huang, and Shawmin Lei, *In-Loop Filters In HEVC*, IN HIGH EFFICIENCY VIDEO CODING (HEVC) at 185 (September 2014) (emphasis added).

231. Further, the HEVC documentation requires that the application of a sample adaptive offset be region based (*e.g.*, applied to a coding block) (“This process is performed on a coding block basis after the completion for the deblocking filter process for the decoded picture”).

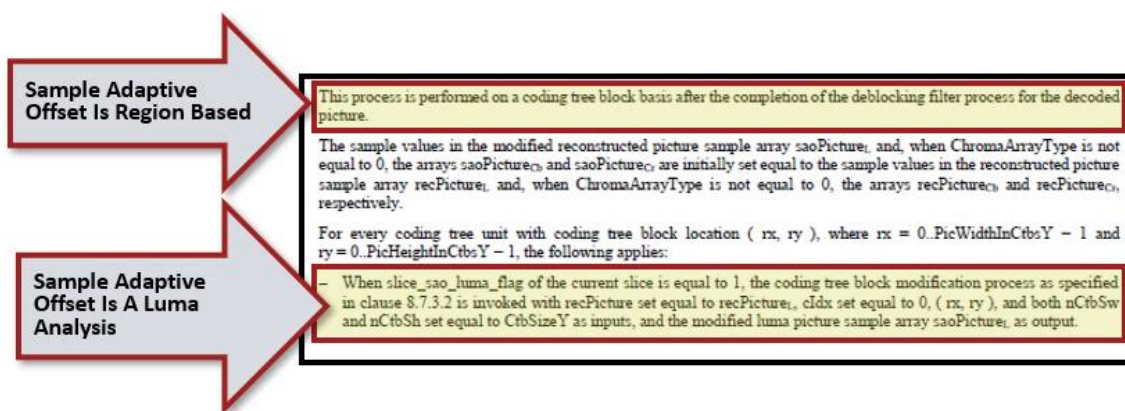

High Efficiency Video Coding, SERIES H: AUDIOVISUAL AND MULTIMEDIA SYSTEMS: INFRASTRUCTURE OF AUDIOVISUAL SERVICES – CODING OF MOVING VIDEO REC. ITU-T H.265 at § 8.7.3.1 (April 2015) (annotations added).

232. On information and belief, the Dell '073 Products contain functionality wherein a decoder applies sample adaptive offset to a decoded reference frame (first frame). Further, the Dell '073 Products apply the sample adaptive offset functions to remap a portion of the region based on luminance values (luma). "SAO can be applied to not only luma but also chroma." Chih-Ming Fu, *et al.*, *Sample Adaptive Offset in the HEVC Standard*, IEEE TRANSACTIONS ON CIRCUITS AND SYSTEMS FOR VIDEO TECHNOLOGY, VOL. 22, NO. 12 at 1765 (December 2012).

233. On information and belief, the Dell '073 Products apply the sample adaptive offset to a coding tree unit (region in the first frame), a luminance analysis is performed using two luminance analysis techniques: Edge Offset ("EO") and Band Offset ("BO"). Edge Offset "uses four 1-D directional patterns for sample classification: horizontal, vertical, 135° diagonal, and 45° diagonal." Chih-Ming Fu, *et al.*, *Sample Adaptive Offset in the HEVC Standard*, IEEE TRANSACTIONS ON CIRCUITS AND SYSTEMS FOR VIDEO TECHNOLOGY, VOL. 22, NO. 12 AT 1757 (December 2012). Band Offset "implies one offset is added to all samples of the same band. The sample value range is equally divided into 32 bands." *Id.* at 1757. The below diagram shows that the Dell '073 Products use different sample adaptive offsets in a region of the first frame in conducting a luminance analysis.

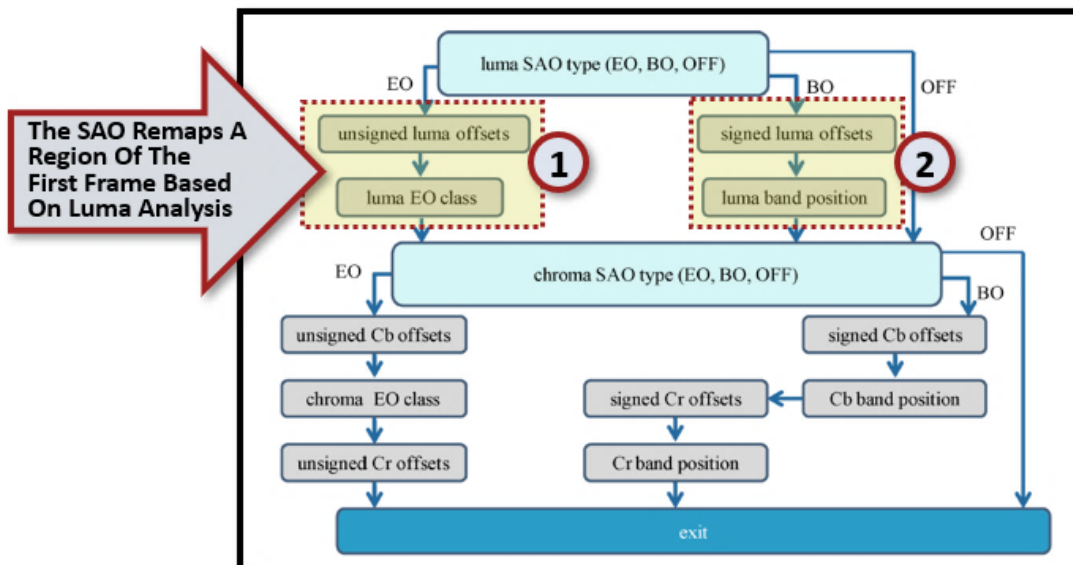

The SAO Remaps A Region Of The First Frame Based On Luma Analysis

Chih-Ming Fu, *et al.*, *Sample Adaptive Offset in the HEVC Standard*, IEEE TRANSACTIONS ON CIRCUITS AND SYSTEMS FOR VIDEO TECHNOLOGY, VOL. 22, NO. 12 AT 1759 (December 2012) (annotations added showing (1) edge offset and (2) band offset luma analysis).

234. Further, HEVC documentation makes clear that the application of the standard adaptive offset remapping policy is based on a luminance analysis. The below shows that slices of a region have a standard adaptive offset applied based on a “luma flag.”

<code>if (sample_adaptive_offset_enabled_flag) {</code>	
<code> slice_sao_luma_flag</code>	<code>u(1)</code>
<code> if (ChromaArrayType != 0)</code>	
<code> slice_sao_chroma_flag</code>	<code>u(1)</code>

High Efficiency Video Coding, SERIES H: AUDIOVISUAL AND MULTIMEDIA SYSTEMS: INFRASTRUCTURE OF AUDIOVISUAL SERVICES – CODING OF MOVING VIDEO REC. ITU-T H.265 at § F.7.3.6.1 (April 2015) (“sample_adaptive_offset_enabled_flag equal to 1 specifies that the sample adaptive offset process is applied to the reconstructed picture after the deblocking filter process.”).

235. Commentary on the use of sample adaptive offset functionality in decoding HEVC video further confirms that the use of Sample Adaptive Offset (such as that implemented by the Dell ‘073 Products) is region based and remaps pixel values in a region of a frame by modifying

pixels based on an offset value. “[A]fter the deblocking filter through a look-up table . . . [and applying] a certain offset value from a look-up-table is added to the sample.”⁹⁸

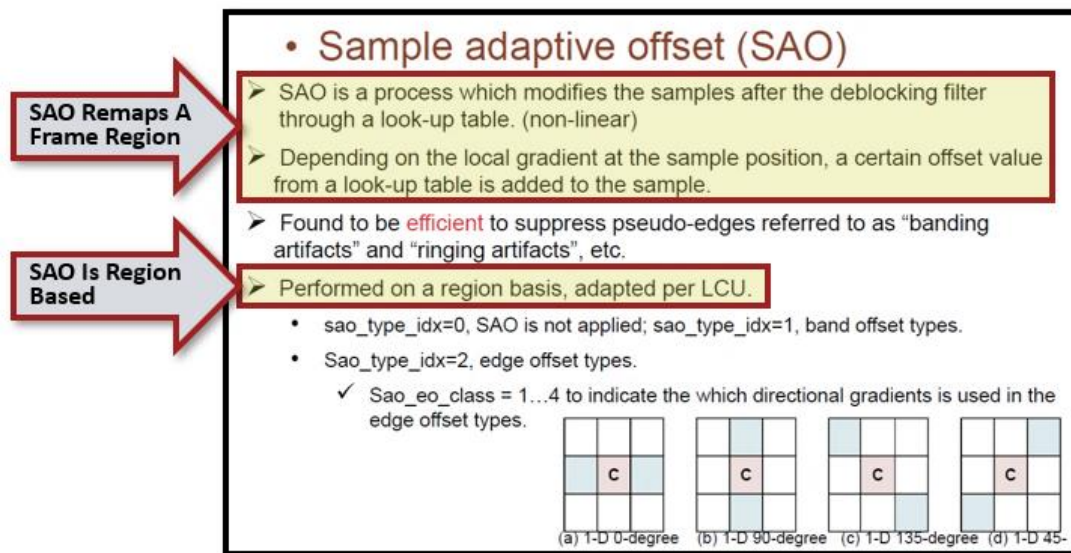

Oscar C. Au, HIGH EFFICIENCY VIDEO CODING (HEVC) PRESENTATION at 43 (October 2013) (annotations added).

236. On information and belief, when the Dell ‘073 Products decode a second frame, the application of the remapping policy (sample adaptive offset) will be determined based on the application of sample adaptive offset to the first frame (reference picture). Thus, the application of the remapping policy (sample adaptive offset) to the first frame has the effect of increasing the quality of the reference picture such that the second frame might no longer require the application of sample adaptive offset (remapping policy).⁹⁹

The second in-loop filter, SAO, is applied to the output of the deblocking filter and further improves the quality of the decoded picture by attenuating ringing artifacts and changes in sample intensity of some areas of a picture. The most important advantage of the in-loop filters is improved subjective quality of reconstructed

⁹⁸ Oscar C. Au, HIGH EFFICIENCY VIDEO CODING (HEVC) PRESENTATION at 43 (October 2013).

⁹⁹ Andrey Norikin, Chih-Ming Fu, Yu-Wen Huang, and Shawmin Lei, *In-Loop Filters In HEVC*, IN HIGH EFFICIENCY VIDEO CODING (HEVC) at 171 (September 2014) (“HEVC defines two in-loop filters, deblocking and sample adaptive offset (SAO), which significantly improve the subjective quality of decoded video sequences as well as compression efficiency by increasing the quality of the reconstructed/ reference pictures.”).

pictures. In addition, using the filters in the decoding loop also increases the quality of the reference pictures and hence also the compression efficiency.

Andrey Norikin, Chih-Ming Fu, Yu-Wen Huang, and Shawmin Lei, *In-Loop Filters In HEVC*, IN HIGH EFFICIENCY VIDEO CODING (HEVC) (Vivienne Sze, Madhukar Budagavi, and Gary J. Sullivan (Editors)) at 171 (September 2014) (annotations added).

237. Sample adaptive offset as implemented by the Dell ‘073 Products is a policy that remaps the values of pixels. If sample adaptive offset is applied to a reference frame, regions in a second frame might not require the application of the remapping policy as the reference frame that was used to generate the second frame was of a better quality.

SAO classifies each pixel into one of four bands or one of four edge types and adds an offset to it. For band offsets, the band of each pixel depends on its value and the position of the four bands. For edge offsets, the edge of each pixel depends on the whether its value is larger or smaller than two of its neighbors. The selection between band offsets and edge offsets, position of bands, choice of neighbors for edge offsets, and values of the offsets are signaled at the CTU level for luma and chroma separately.

Mehul Tikekar, *et al.*, *Decoder Hardware Architecture for HEVC*, HIGH EFFICIENCY VIDEO CODING (HEVC) at 335 (September 2014).

238. The following excerpt from a presentation describing HEVC decoding provides details on how the application of sample adaptive offset remaps pixel values by adding an offset to the pixel value based on a luma analysis.

SAO Remapping Policy Changes Pixel Values

Sample adaptive offset (SAO)

- For a specified EO type, decoder derives for each pixel which category it belongs to, and then add the received offset of the category to the pixel
 - 4 offsets are sent to decoder for categories 1~4
 - Offset value should be ≥ 0 for category 1 & 2, and ≤ 0 for category 3 & 4.

Category	Condition
1	$c < 2$ neighboring pixel values
2	$c < 1$ neighbor && $c == 1$ neighbor
3	$c > 1$ neighbor && $c == 1$ neighbor
4	$c > 2$ neighbors
0	None of the above

Oscar C. Au, HIGH EFFICIENCY VIDEO CODING (HEVC) PRESENTATION at 44 (October 2013) (annotation added).

239. The Dell '073 Products receive encoded video data wherein the second frame includes a region encoding a motion vector difference in position between the region corresponding to the second frame indicating the first frame, the motion vector defines a region between the frame and the second frame corresponding to the first region the correspondence relationship. Specifically, the encoded video data received by the Dell '073 Products use a translational motion model wherein the position of the block in a previously decoded picture is indicated by a motion vector: Δx ; Δy where Δx specifies the horizontal and Δy the vertical displacement relative to the position of the current block. The motion vectors: Δx and Δy are of fractional sample accuracy to more accurately capture the movement of the underlying object. Interpolation is applied on the reference pictures to derive the prediction signal when the corresponding motion vector has fractional sample accuracy. The previously decoded picture is referred to as the reference picture and indicated by a reference index Δt to a reference picture list. These translational motion model parameters, *i.e.*, motion vectors and reference indices, are further referred to as motion data.

240. On information and belief, one or more of the Dell '073 Products enable the provision of enhanced video pictures with minimal additional hardware costs for the components required to successfully process the video data.

241. On information and belief, one or more of the Dell '073 Products include an input for receiving a video stream containing encoded frame-based video information including an encoded first frame and an encoded second frame.

2.2 Parallel De-Blocking

HEVC has already adopted the frame-based filtering process proposed by Sony Corporation [14]. On this condition, the horizontal filtering is performed firstly to all the LCUs in the processing picture, and then the vertical filtering is performed to all the LCUs later, which is also called frame-based processing. In H.264/AVC, the

Ming-Ting Sun, *et al.*, *Advances in Multimedia Information Processing*, PCM 2012: 13TH PACIFIC-RIM CONFERENCE ON MULTIMEDIA PROCEEDINGS VOLUME 7674 at 274 (December 4-6, 2012) (“HEVC has already adopted the frame-based filtering process proposed by Sony Corporation.”).

242. On information and belief, one or more of the Dell ‘073 Products include a video decoder comprising an input for receiving video information wherein the encoding of the second frame depends on the encoding of the first frame, the encoding of the second frame includes motion vectors indicating differences in positions between regions of the second frame and corresponding regions of the first frame, the motion vectors define correspondence between regions of the second frame and corresponding regions of the first frame. The Overview of Design Characteristics in the HEVC Standard describes the use of “motion vectors for block-based inter prediction to exploit temporal statistical dependencies between frames.”

compression. Encoding algorithms (not specified in this Recommendation | International Standard) may select between inter and intra coding for block-shaped regions of each picture. Inter coding uses motion vectors for block-based inter prediction to exploit temporal statistical dependencies between different pictures. Intra coding uses various spatial prediction modes to exploit spatial statistical dependencies in the source signal for a single picture. Motion vectors and intra prediction modes may be specified for a variety of block sizes in the picture. The prediction residual may then be further compressed using a transform to remove spatial correlation inside the transform block before it is quantized, producing a possibly irreversible process that typically discards less important visual information while forming a close approximation to the source samples. Finally, the motion vectors or intra prediction modes may also be further compressed using a variety of prediction mechanisms, and, after prediction, are combined with the quantized transform coefficient information and encoded using arithmetic coding.

High Efficiency Video Coding, SERIES H: AUDIOVISUAL AND MULTIMEDIA SYSTEMS: INFRASTRUCTURE OF AUDIOVISUAL SERVICES – CODING OF MOVING VIDEO REC. ITU-T H.265 at § 0.7 (April 2015) (annotation added).

243. On information and belief, one or more of the Dell ‘073 Products include a video decoder comprising a decoding unit for decoding the frames, wherein the decoding unit recovers

the motion vectors for the second frame. Further, HEVC documentation shows that “motion vectors are used during the decoding process for prediction units in inter prediction mode.”

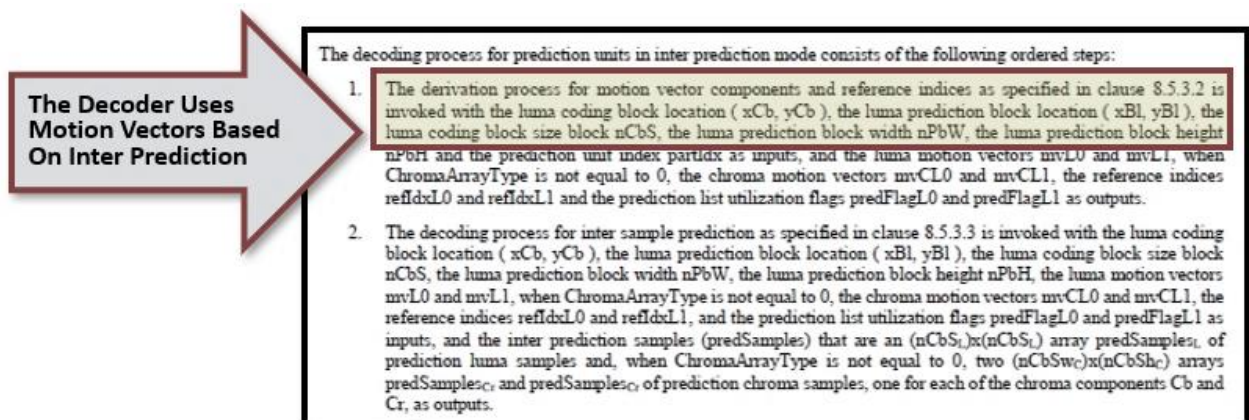

High Efficiency Video Coding, SERIES H: AUDIOVISUAL AND MULTIMEDIA SYSTEMS: INFRASTRUCTURE OF AUDIOVISUAL SERVICES – CODING OF MOVING VIDEO REC. ITU-T H.265 at § 8.5.3.1 (April 2015) (annotation added).

244. On information and belief, one or more of the Dell ‘073 Products include a video decoder comprising a processing component configured to determine a re-mapping strategy for video enhancement of the decoded first frame using a region-based analysis, re-map the first frame using the re-mapping strategy, and re-map one or more regions of the second frame depending on the re-mapping strategy for corresponding regions of the first frame.

245. On information and belief, one or more Dell subsidiaries and/or affiliates use the Dell ‘073 Products in regular business operations.

246. On information and belief, the Dell ‘073 Products are available to businesses and individuals throughout the United States.

247. On information and belief, the Dell ‘073 Products are provided to businesses and individuals located in the Southern District of New York.

248. By making, using, testing, offering for sale, and/or selling products and services for enhancing subsequent images of a video stream in which frames are encoded based on previous

frames using prediction and motion estimation, including but not limited to the Dell '073 Products, Dell has injured Dynamic Data and is liable to the Plaintiff for directly infringing one or more claims of the '073 patent, including at least claim 14 pursuant to 35 U.S.C. § 271(a).

249. On information and belief, Dell also indirectly infringes the '073 patent by actively inducing infringement under 35 U.S.C. § 271(b).

250. Dell has had knowledge of the '073 patent since at least service of the Original Complaint in this case or shortly thereafter, and on information and belief, Dell knew of the '073 patent and knew of its infringement, including by way of this lawsuit.

251. On information and belief, Dell intended to induce patent infringement by third-party customers and users of the Dell '073 Products and had knowledge that the inducing acts would cause infringement or was willfully blind to the possibility that its inducing acts would cause infringement. Dell specifically intended and was aware that the normal and customary use of the accused products would infringe the '073 patent. Dell performed the acts that constitute induced infringement, and would induce actual infringement, with knowledge of the '073 patent and with the knowledge that the induced acts would constitute infringement. For example, Dell provides the Dell '073 Products that have the capability of operating in a manner that infringe one or more of the claims of the '073 patent, including at least claim 14, and Dell further provides documentation and training materials that cause customers and end users of the Dell '073 Products to utilize the products in a manner that directly infringe one or more claims of the '073 patent.¹⁰⁰

By providing instruction and training to customers and end-users on how to use the Dell '073

¹⁰⁰ See, e.g., *Dell G7 15*, SETUP AND SPECIFICATIONS (2018); *Alienware Graphics Amplifier*, USER'S GUIDE (2014); *Alienware Aurora R8*, SETUP AND SPECIFICATIONS (2018); *Inspiron 15 7000 Gaming*, SERVICE MANUAL (2017-2018); *XPS 13*, SETUP AND SPECIFICATIONS (2017); *Dell Latitude 5420/E5420/E5420m*, OWNER'S MANUAL (2011); *Alienware M17x R4*, OWNER'S MANUAL (2012); *Dell Vostro 15-3558*, OWNER'S MANUAL (2015).

Products in a manner that directly infringes one or more claims of the '073 patent, including at least claim 14, Dell specifically intended to induce infringement of the '073 patent. On information and belief, Dell engaged in such inducement to promote the sales of the Dell '073 Products, e.g., through Dell user manuals, product support, marketing materials, and training materials to actively induce the users of the accused products to infringe the '073 patent. Accordingly, Dell has induced and continues to induce users of the accused products to use the accused products in their ordinary and customary way to infringe the '073 patent, knowing that such use constitutes infringement of the '073 patent.

252. The '073 patent is well-known within the industry as demonstrated by multiple citations to the '073 patent in published patents and patent applications assigned to technology companies and academic institutions. Dell is utilizing the technology claimed in the '073 patent without paying a reasonable royalty. Dell is infringing the '073 patent in a manner best described as willful, wanton, malicious, in bad faith, deliberate, consciously wrongful, flagrant, or characteristic of a pirate.

253. To the extent applicable, the requirements of 35 U.S.C. § 287(a) have been met with respect to the '073 patent.

254. As a result of Dell's infringement of the '073 patent, Dynamic Data has suffered monetary damages, and seeks recovery in an amount adequate to compensate for Dell's infringement, but in no event less than a reasonable royalty for the use made of the invention by Dell together with interest and costs as fixed by the Court.

COUNT IV
INFRINGEMENT OF U.S. PATENT NO. 8,073,054

255. Dynamic Data references and incorporates by reference the preceding paragraphs of this Complaint as if fully set forth herein.

256. Dell designs, makes, uses, sells, and/or offers for sale in the United States products and/or services for estimating a current motion vector for a group of pixels of an image.

257. Dell designs, makes, sells, offers to sell, imports, and/or uses Dell devices that contain H.265 video compression functionality, including but not limited to Dell desktops, laptops, and all-in-one devices including the following exemplary models: Dell G3 3579, Dell G3 3779, Dell G5 15 5587, Dell G7 15 7588, Dell Precision 5530, Inspiron 14 Gaming 7466, Inspiron 14 Gaming 7467, Inspiron 15 Gaming 7566, Inspiron 15 Gaming 7567, Inspiron 15 Gaming 7577, Inspiron 7472, Inspiron 7572, Inspiron G3 3579, Inspiron G3 3779, Latitude 3190, Latitude 3190 2-in-1, Latitude 5420, Latitude 5424, Latitude 5491, Latitude 5591, Latitude 7424, Optiplex 3060, Optiplex 5060, Optiplex 5260 AIO, Optiplex 7060, Optiplex 7460 AIO, Optiplex 7760 AIO, Optiplex XE3, Precision 3430, Precision 3430 XL Tower, Precision 3530, Precision 3630, Precision 3630 XL Tower, Precision 3930 Rack, Precision 3930 XL RACK, Precision 5510, Precision 5520, Precision 5530, Precision 7530, Precision 7730, Precision M3800, XPS 13 9360, XPS 13 9365 2-in-1, XPS 13 9370, XPS 15 9550, XPS 15 9560, XPS 15 9570, XPS 15 9575 2-in-1, XPS Notebook 9365, XPS Notebook 9530, XPS Notebook 9550, XPS Notebook 9560, and, XPS Notebook 9570, Alienware 15, Alienware 15 R2, Alienware 15 R3, Alienware 15 R4, Alienware 17, Alienware 17 R2, Alienware 17 R3, Alienware 17 R4, Alienware 17 R5, Alienware 18, Alienware Area 51, Alienware Area-51 ALX, Alienware Area-51 R2, Alienware Area-51 R4 and R5, Alienware Area-51 Threadripper Edition R3 and R6, Alienware Area-51 Threadripper Edition R7, Alienware Aurora, Alienware Aurora ALX, Alienware Aurora R2, Alienware Aurora

R3, Alienware Aurora R4, Alienware Aurora R5, Alienware Aurora R6, Alienware Aurora R7, Alienware Aurora R8, Alienware m15, Alienware M15x, Alienware M17x, Alienware M17x R2, Alienware M17x R3, Alienware M17x R4, Alienware M18x, Alienware M18x R2, Alienware X51, Alienware X51 R2, and Alienware X51 R3 (collectively, the “Dell ‘054 Product(s)”).

258. The Dell ‘054 Products perform video processing compliant with the HEVC standard. *See e.g., Dell Desktop Support, DELL SUPPORT WEBSITE, available at: https://www.dell.com/support/home/us/en/19/products/desktop; Dell Laptop Support, DELL SUPPORT WEBSITE, available at: https://www.dell.com/support/home/us/en/19/products/laptop*

259. The below table shows Dell ‘054 Products that contain the infringing HEVC compliant video processing technology.

Exemplar Dell Models	Graphics Processing Unit (GPU)	HEVC Decode/Encode ¹⁰¹
Dell G3 3579	NVIDIA GeForce GTX 1050 Ti ¹⁰²	Yes
Dell G3 3779	NVIDIA GeForce GTX 1060 w/ Max Q ¹⁰³	Yes
Dell G5 15 5587	NVIDIA GeForce GTX 1060 w/ Max Q ¹⁰⁴	Yes
Dell G7 15 7588	NVIDIA GeForce GTX 1060 w/ Max Q ¹⁰⁵	Yes
Inspiron 14 Gaming 7466	Intel HD Graphics 530 ¹⁰⁶	Yes
Inspiron 14 Gaming 7467	Intel HD Graphics 630 ¹⁰⁷	Yes

¹⁰¹ *NVIDIA Video Encode And Decode GPU Support Matrix*, NVIDIA DEVELOPER WEBSITE, available at: <https://developer.nvidia.com/video-encode-decode-gpu-support-matrix> (showing support for HEVC in NVIDIA Graphics cards); *Intel Product Matrix*, INTEL WEBSITE, available at: <https://www.intel.com/content/www/us/en/products> (showing HEVC Support); *Intel Graphics Product Specifications*, INTEL WEBSITE, available at: <https://www.intel.com/content/www/us/en/architecture-and-technology/visual-technology/graphics-overview.html>.

¹⁰² *Dell Model G3 3579*, DELL WEBSITE, available at: <https://www.dell.com/en-us/work/shop/dell-laptops-and-notebooks/dell-g3-15-gaming-laptop/spd/g-series-15-3579-laptop>

¹⁰³ *Dell Model G3 3779*, DELL WEBSITE, available at: <https://www.dell.com/en-us/shop/dell-laptops/dell-g3-17-gaming/spd/g-series-17-3779-laptop>

¹⁰⁴ *Dell Model G5 15 5587*, DELL WEBSITE, available at: <https://www.dell.com/en-us/shop/dell-laptops/dell-g5-15-gaming/spd/g-series-15-5587-laptop>

¹⁰⁵ *Dell Model G7 15 7588*, DELL WEBSITE, available at: <https://www.dell.com/en-us/shop/dell-laptops/dell-g7-15-gaming/spd/g-series-15-7588-laptop>

¹⁰⁶ *Dell Inspiron 14 Gaming Setup and Specifications*, DELL MANUAL MODEL NO. INSPIRON 14-7466 at 18 (2016).

¹⁰⁷ *Dell Inspiron 14 7000 Gaming Series Setup and Specifications*, DELL SPECIFICATIONS MODEL NO. INSPIRON 14-7467 at 18 (2016)

Inspiron 15 Gaming 7566	Intel HD Graphics 530 (Integrated) / NVIDIA GeForce GTX630M (Discrete) ¹⁰⁸	Yes
Inspiron 15 Gaming 7567	NVIDIA GeForce GTX 1050Ti with 4GB GDDR5 / NVIDIA GeForce GTX 1050 with 4GB GDDR5 ¹⁰⁹	Yes
Inspiron 15 Gaming 7577	Intel HD Graphics 630 (Integrated) / NVIDIA GeForce GTX 1050/ GTX 1050 Ti/ GTX 1060 Max-Q (Discrete) ¹¹⁰	Yes
Inspiron 5457	Intel HD Graphics 520 (integrated) / NVIDIA GeForce 930M (Discrete) ¹¹¹	Yes
Inspiron 5458	Intel HD Graphics 4400/4500 (integrated) / NVIDIA GeForce 920M (discrete) ¹¹²	Yes
Inspiron 5557	Intel HD Graphics 520 (integrated) / NVIDIA GeForce 930M (discrete) ¹¹³	Yes
Inspiron 5558	Intel HD Graphics 4400/4500 (integrated) / NVIDIA GeForce 920M (discrete) ¹¹⁴	Yes
Inspiron 5587	NVIDIA GeForce GTX 1060 Max-Q ¹¹⁵	Yes
Inspiron 5758	Intel HD Graphics 4400/4500 (integrated) / NVIDIA GeForce 920M (discrete) ¹¹⁶	Yes
Inspiron 7447	Intel Iris Pro Graphic 5200 (integrated) / NVIDIA GeForce GTX 850M (discrete) ¹¹⁷	Yes
Inspiron 7460	Intel HD Graphics 610/620/635 (integrated)/ NVIDIA GeForce 940M ¹¹⁸	Yes
Inspiron 7466	Intel HD Graphics 530 (integrated) / NVIDIA GeForce GTX 950M ¹¹⁹	Yes
Alienware Area 51	NVIDIA GeForce RTX 2080 Ti OC with 11GB GDDR6 ¹²⁰	Yes
Alienware Area-51 R2	NVIDIA® GeForce GTX ¹²¹	Yes

¹⁰⁸ *Dell Inspiron 15 Gaming Setup and Specifications*, DELL MANUAL MODEL NO. 15-7566 at 18 (2016)

¹⁰⁹ *Dell Inspiron Model 7567*, DELL WEBSITE, available at: <https://www.dell.com/us/dfh/p/inspiron-15-7567-laptop/pd>

¹¹⁰ *Dell Inspiron 15 7000 Gaming Setup and Specifications*, DELL MANUAL MODEL NO. INSPIRON 15-7577 at 23 (2018).

¹¹¹ *Dell Inspiron 14 5000 Series Specification*, DELL SPECIFICATIONS MODEL NO. INSPIRON 14-5457 at 12 (2015).

¹¹² *Dell Inspiron 14 5000 Series Specification*, DELL SPECIFICATIONS MODEL NO. INSPIRON 14-5458 at 12 (2015).

¹¹³ *Dell Inspiron 14 5000 Series Specification*, DELL SPECIFICATIONS MODEL NO. INSPIRON 14-5557 at 12 (2015).

¹¹⁴ *Dell Inspiron 14 5000 Series Specification*, DELL SPECIFICATIONS MODEL NO. INSPIRON 14-5558 at 12 (2015).

¹¹⁵ *Dell Inspiron Model 5587*, DELL WEBSITE, available at: <https://www.dell.com/en-us/shop/dell-laptops/dell-g5-15-gaming/spd/g-series-15-5587-laptop>

¹¹⁶ *Dell Inspiron 17 5000 Series Specification*, DELL SPECIFICATIONS MODEL NO. INSPIRON 17-5758 at 12 (2015).

¹¹⁷ *Dell Inspiron 14 7000 Series Specification*, DELL SPECIFICATIONS MODEL NO. INSPIRON 7447 at 12 (2014).

¹¹⁸ *Dell Inspiron 14 7000 Setup and Specification*, DELL MANUAL MODEL NO. INSPIRON 14-7460 at 18 (2018).

¹¹⁹ *Dell Inspiron 14 Gaming Setup and Specifications*, DELL MANUAL MODEL NO. INSPIRON 14-7466 at 18 (2016).

¹²⁰ *Dell Alienware Specifications*, DELL WEBSITE, available at: <https://www.dell.com/en-us/shop/dell-desktop-computers/alienware-area-51/spd/alienware-area51-r5>.

¹²¹ *Dell Alienware Specifications*, DELL WEBSITE, available at: <https://www.dell.com/en-us/shop/cty/pdp/spd/alienware-area51-r2>.

Alienware Area-51 R4/R5	NVIDIA® GeForce GTX ¹²²	Yes
Alienware Area-51 Threadripper R3/R6	NVIDIA GeForce GTX 1080 ¹²³	Yes
Alienware Area-51 Threadripper Edition R7	Dual NVIDIA® GeForce® RTX 2080 Ti OC ¹²⁴	Yes
Alienware Aurora	NVIDIA® GeForce® RTX 2080 Ti OC with 11GB GDDR6 ¹²⁵	Yes

260. Dell documentation states that the Dell ‘054 Products are compliant with the HEVC standard as shown in the following excerpts.

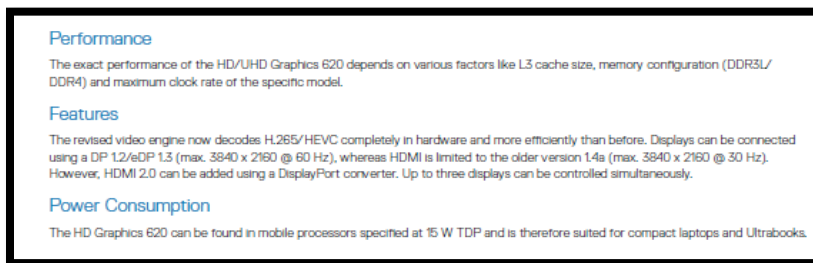

DELL LATITUDE 5420 RUGGED OWNER’S MANUAL at 44 (2015) (“The revised video engine now decodes H.265/HEVC completely in hardware and more efficiently than before.”).

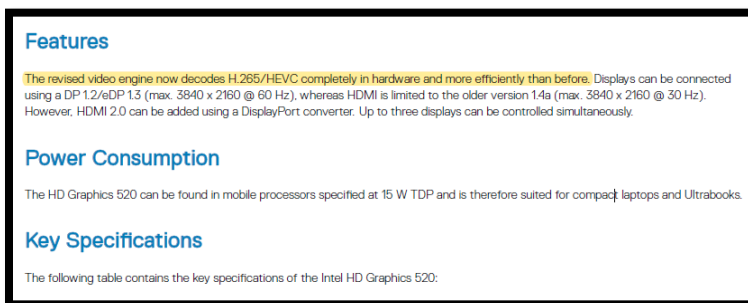

DELL VOSTRO 14-3468 OWNER’S MANUAL at 55 (2018) (annotation added) (“The revised video engine now decodes H.265/HEVC completely in hardware and more efficiently than before.”).

¹²² Dell Alienware Specifications, DELL WEBSITE, available at: <https://www.dell.com/en-us/shop/dell-desktop-computers/alienware-area-51-gaming-desktop/spd/alienware-area51-r4>.

¹²³ Dell Alienware Specifications, DELL WEBSITE, available at: <https://www.dell.com/en-us/shop/dell-desktop-computers/alienware-area-51-threadripper-edition/spd/alienware-area51-r6>.

¹²⁴ Dell Alienware Specifications, DELL WEBSITE, available at: <https://www.dell.com/en-us/shop/desktops/area-51-threadripper/spd/alienware-area51-r7>.

¹²⁵ Dell Alienware Specifications, DELL WEBSITE, available at: <https://www.dell.com/en-us/shop/dell-desktop-computers/alienware-aurora/spd/alienware-aurora-r7-desktop>.



DELL PRODUCT QUICK REFERENCE MATRIX Q4 2018 at 17 (2018) (“New HEVC 10-bit and VP9 decode”).

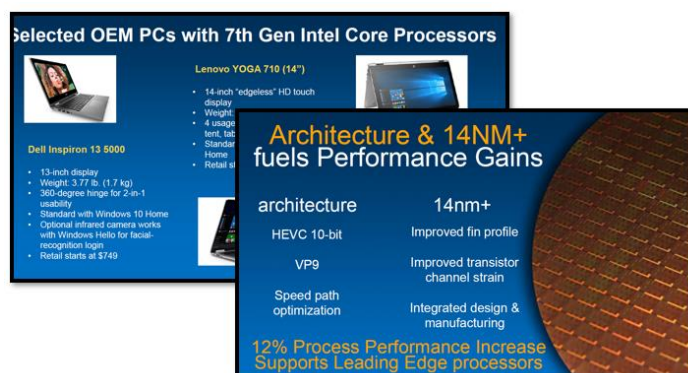

David Bradshaw, *7th Generation Intel Core Processor*, INTEL PRESENTATION at 3 & 12 (2016).

261. Documentation from Dell shows that the Dell ‘054 Products perform a motion vector estimation method. Dell ‘054 Products perform the method of encoding video content using High Efficiency Video Coding (“HEVC”).

262. On information and belief, the Dell ‘054 Products contain a processor for decoding the received encoded frame-based encoded video data. Further, the Dell Products apply a remapping policy to the first frame of decoded video data using a region-based luma analysis. As part of the decoding process performed by Dell Products, a reference picture (first frame) is decoded and two in-loop filters (deblocking and a sample adaptive offset) are applied to the reference picture.

263. On information and belief, the Dell ‘054 Products contain a video encoder that selects an image segment of a second video image corresponding to an image segment of a first video image. The image segment has an image segment center.

264. On information and belief, one or more of the Dell ‘054 Products include technology for estimating a current motion vector for a group of pixels of an image

265. On information and belief, Dell has directly infringed and continues to directly infringe the ‘054 patent by, among other things, making, using, offering for sale, and/or selling technology for estimating a current motion vector for a group of pixels of an image, including but not limited to the Dell ‘054 Products.

266. On information and belief, by complying with the HEVC standard, Dell’s devices – such as the Dell ‘054 Products – necessarily infringe the ‘054 patent. Mandatory sections of the HEVC standard require the elements required by certain claims of the ‘054 patent, including but not limited to claim 1. *High Efficiency Video Coding*, SERIES H: AUDIOVISUAL AND Multimedia SYSTEMS: INFRASTRUCTURE OF AUDIOVISUAL SERVICES – CODING OF MOVING VIDEO REC. ITU-T H.265 (February 2018) (The following sections of the HEVC Standard are relevant to Dell’s infringement of the ‘054 patent: “7.3.4 Scaling list data syntax;” 7.3.6.1 General slice segment header syntax;” “7.3.6.3 Weighted prediction parameters syntax;” “7.3.8.14 Delta QP syntax;” “7.4.4 Profile, tier and level semantics;” and “7.4.7.3 Weighted prediction parameters semantics.”

267. On information and belief, the Dell ‘054 Products comprise functionality for generating a set of candidate motion vectors for a grouping of pixels (prediction unit). The HEVC standard generates a set of candidate motion vectors for the group of pixels, with the candidate

motion vectors being extracted from a set of previously estimated motion vectors. After the candidate motion vectors are generated, only the best candidate index is transmitted.

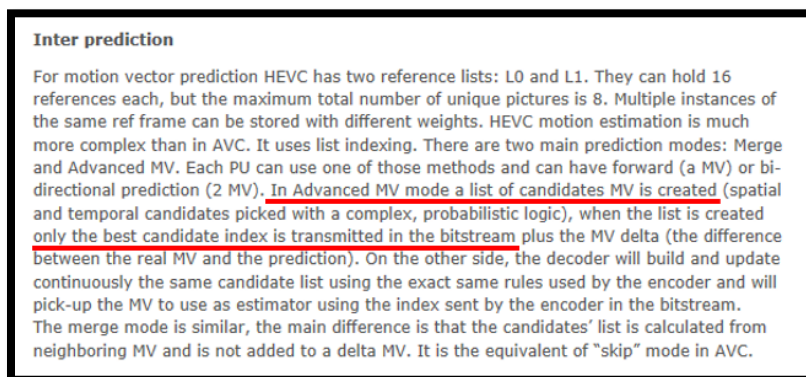

Fabio Sonnati, *H265 – Part I: Technical Overview*, VIDEO ENCODING & STREAMING TECHNOLOGIES WEBSITE (June 20, 2014) (emphasis added).

268. On information and belief, one or more of the Dell '054 Products enable motion estimation with a relatively fast convergence in finding the appropriate motion vectors of the motion vector fields by adding a further candidate motion vector to the set of candidate motion vectors.

HEVC introduces a so-called merge mode, which sets all motion parameters of an inter picture predicted block equal to the parameters of a merge candidate [6]. The merge mode and the motion vector prediction process optionally allow a picture to reuse motion vectors of prior pictures for motion vector coding,

Frank Bossen, *et al.*, *HEVC Complexity and Implementation Analysis*, IEEE TRANSACTIONS ON CIRCUITS AND SYSTEMS FOR VIDEO TECHNOLOGY VOL. 22 NO. 12 at 1686 (December (2012)).

269. On information and belief, the following block diagram illustrates the form of encoded video data received by the Dell '054 Products. Specifically, the encoded video data received by the Dell '054 Products is encoded using inter-picture prediction where the motion data of a block is correlated with neighboring blocks. To exploit this correlation, motion data is not directly coded in the bitstream, but predictively coded based on neighboring motion data. Further, the Dell '054 Products receive data that is encoded using advanced motion vector prediction where

the best predictor for each motion block is signaled to the decoder. In addition, inter-prediction block merging derives all motion data of a block from the neighboring blocks.

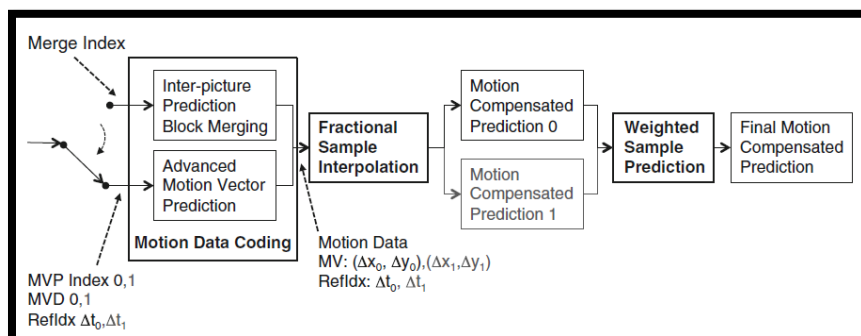

Benjamin Bross, *et al.*, *Inter-Picture Prediction in HEVC*, In HIGH EFFICIENCY VIDEO CODING (HEVC) at 115 (2014).

270. On information and belief, the Dell ‘054 products carry out a block-based motion vector estimation process that involves comparing a plurality of candidate vectors to determine block-based motion vectors. The Dell ‘054 Products generate two predictor candidate motion vectors (a spatial motion vector and temporal motion vector). The first predictor candidate motion vector is drawn from a list of spatial motion vector candidates.

three spatially neighboring MVs. HEVC improves the MV prediction by applying an MV prediction competition as initially proposed in [18]. In HEVC, this competition was further adapted to large block sizes with so-called *advanced motion vector prediction* (AMVP) in [19]. In the DIS Main profile, AMVP has two predictor candidates competing for the prediction. Two spatial motion vector predictor (MVP) candidates are considered and, when at least one of them is not available or they are redundant, a temporal motion vector prediction (TMVP) candidate is considered. The candidates

Philipp Helle, Simon Oudin, Benjamin Bross, Detlev Marpe, M. Oguz Bici, Kemal Ugur, Joel Jung, Gordon Clare, and Thomas Wiegand, *Block Merging for Quadtree-Based Partitioning in HEVC*, *IEEE TRANS. CIR. AND SYS. FOR VIDEO TECHNOLOGY*, Vol. 22 No. 12 (December 2012) (“AMVP has two predictor candidates competing for the prediction. Two spatial motion vector predictor (MVP) candidates are considered and, when at least one of them is not available or they are redundant, a temporal motion vector prediction (TMVP) candidate is considered.”).

271. On information and belief, one or more of the Dell '054 Products include a motion estimation unit comprising a generating unit for generating a set of candidate motion vectors for the group of pixels, with the candidate motion vectors being extracted from a set of previously estimated motion vectors.

272. On information and belief, the Dell '054 Products contain functionality for generating match errors of the respective candidate motion vectors. The HEVC standard calculates match errors of respective candidate motion vectors. The match errors are referred to as the MV delta. The MV delta is the difference between the real MV and the candidate prediction.

Inter prediction

For motion vector prediction HEVC has two reference lists: L0 and L1. They can hold 16 references each, but the maximum total number of unique pictures is 8. Multiple instances of the same ref frame can be stored with different weights. HEVC motion estimation is much more complex than in AVC. It uses list indexing. There are two main prediction modes: Merge and Advanced MV. Each PU can use one of those methods and can have forward (a MV) or bi-directional prediction (2 MV). In Advanced MV mode a list of candidates MV is created (spatial and temporal candidates picked with a complex, probabilistic logic), when the list is created only the best candidate index is transmitted in the bitstream plus the MV delta (the difference between the real MV and the prediction). On the other side, the decoder will build and update continuously the same candidate list using the exact same rules used by the encoder and will pick-up the MV to use as estimator using the index sent by the encoder in the bitstream. The merge mode is similar, the main difference is that the candidates' list is calculated from neighboring MV and is not added to a delta MV. It is the equivalent of "skip" mode in AVC.

Fabio Sonnati, *H265 – Part I: Technical Overview*, VIDEO ENCODING & STREAMING TECHNOLOGIES WEBSITE (June 20, 2014) (emphasis added).

273. On information and belief, any implementation of the HEVC standard would infringe the '054 patent as every implementation of the standard requires the elements in one or more claims of the '054 patent, including but not limited to claim 1, by way of example: a match error unit for calculating match errors of respective candidate motion vectors and calculating the further candidate motion vector by calculating a difference between the second motion vector and the first motion vector.

274. On information and belief, one or more of the Dell ‘054 Products include a motion estimation unit comprising a selector for selecting the current motion vector from the candidate motion vectors by comparing the match errors of the respective candidate motion vectors, characterized in that the motion estimation unit is arranged to add a further candidate motion vector to the set of candidate motion vectors by calculating the further candidate motion vector on the basis of a first motion vector and a second motion vector, both belonging to the set of previously estimated motion vectors.

275. On information and belief, the Dell ‘054 Products select the current motion vector from the candidate motion vectors by comparing the match errors of the respective candidate motion vectors, characterized in that the motion estimation unit is arranged to add a further candidate motion vector to the set of candidate motion vectors by calculating the further candidate motion vector on the basis of a first motion vector and a second motion vector, both belonging to the set of previously estimated motion vectors. The first motion vector is labeled ‘A’ and the second motion vector is labeled ‘B.’

Spatial Candidates

As already mentioned, two spatial MVP candidates A and B are derived from five spatially neighboring blocks which are shown in Fig. 5.4b. The locations of the spatial candidate blocks are the same for both AMVP and inter-prediction block merging that will be presented in Sect. 5.2.2.

Gary Sullivan, *et al.*, HIGH EFFICIENCY VIDEO CODING (HEVC) ALGORITHMS AND ARCHITECTURES at 117 (2014) (emphasis added).

276. Further, the Dell ‘054 Products perform motion vector “competition / weighted sample prediction” by comparing the match errors of the candidate motion vectors. The match errors generated by the Dell ‘054 Products comprise the difference value between the second motion vector and the first motion vector. Documentation of the encoding process states that the

encoder will “pick up the MV [motion vector] to use as an estimator using the index sent by the encoder in the bitstream.”

Inter prediction

For motion vector prediction HEVC has two reference lists: L0 and L1. They can hold 16 references each, but the maximum total number of unique pictures is 8. Multiple instances of the same ref frame can be stored with different weights. HEVC motion estimation is much more complex than in AVC. It uses list indexing. There are two main prediction modes: Merge and Advanced MV. Each PU can use one of those methods and can have forward (a MV) or bi-directional prediction (2 MV). In Advanced MV mode a list of candidates MV is created (spatial and temporal candidates picked with a complex, probabilistic logic), when the list is created only the best candidate index is transmitted in the bitstream plus the MV delta (the difference between the real MV and the prediction). On the other side, the decoder will build and update continuously the same candidate list using the exact same rules used by the encoder and will pick-up the MV to use as estimator using the index sent by the encoder in the bitstream. The merge mode is similar, the main difference is that the candidates' list is calculated from neighboring MV and is not added to a delta MV. It is the equivalent of "skip" mode in AVC.

Fabio Sonnati, *H.265 – Part I: Technical Overview*, VIDEO ENCODING & STREAMING TECHNOLOGIES WEBSITE (June 20, 2014) (emphasis added).

277. On information and belief, the Dell ‘054 Products calculate the square of the difference between two corresponding pixels of the spatial position of the candidate block where the motion vector is located and the spatial position where the reference motion vector is located. As a result, this value is used to assess the similarity, or the matching degree, of a candidate block. Thus, in order to obtain the best matching vector, the Dell ‘054 Products apply a penalty value to every candidate block with a different motion vector (MV_x , MV_y) within the search window defined by the search range in the reference frame. Finally, a candidate block with the minimum penalty value will be denoted as the best matching block and used to calculate the best motion vector from the candidate motion vectors. The below excerpt from an article discussing the selection of a best motion vector describes that the selection of a motion vector is based on the position of the motion vector.

The entire ME process is made up of three coarse-to-fine procedures, namely, MV prediction, integer-pixel ME and fractional-pixel ME. First, MV prediction predicts the start search position for the following motion search by utilizing the neighboring motion information. In HEVC, Advanced Motion Vector Prediction (AMVP), a new and effective technology that predicts the starting search position by referencing the motion vector (MV) information of spatial and temporal motion vector candidates, is adopted, which derives several most probable candidates based on data from adjacent PBs and the reference picture. The displacement between the starting search position and the current coding PU is called a predictive motion vector (PMV). HEVC also introduces a merge mode to derive the motion information from spatially or temporally neighboring blocks [1].

Yongfei Zhang, Chao Zhang, and Rui Fan, *Fast Motion Estimation in HEVC Inter Coding: An Overview of Recent Advances*, PROCEEDINGS, APSIPA ANNUAL SUMMIT AND CONFERENCE 2018 at 1 (November 2018) (emphasis added).

278. On information and belief, one or more of the Dell ‘054 Products include a motion estimation unit that calculates the further candidate motion vector on the basis of the first motion vector and the second motion vector, with the first motion vector belonging to a first forward motion vector field and the second motion vector belonging to a second forward motion vector field, with the first forward motion vector field and the second forward motion vector field being different. Specifically, the HEVC standard arranges to calculate the further candidate motion vector by calculating a difference between the second motion vector and the first motion vector. The further candidate motion vector is calculated at the end of the process (see the red box in the below diagram).

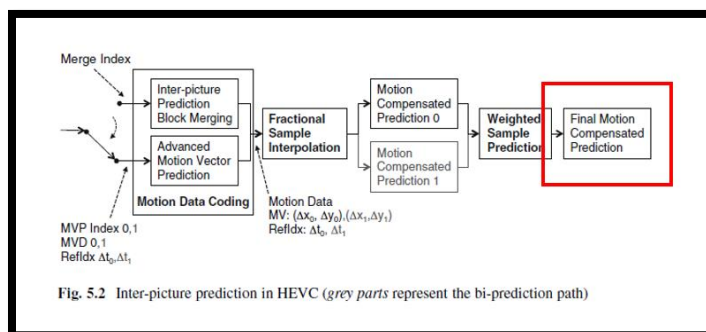

Gary J. Sullivan, *et al.*, HEVC, HIGH EFFICIENCY VIDEO CODING (HEVC) at 115 (September 2014) (emphasis added).

279. On information and belief, one or more of the Dell '054 Products include a motion estimation unit that arranges to calculate the further candidate motion vector by calculating a difference between the second motion vector and the first motion vector.

280. On information and belief, the Dell '054 Products are available to businesses and individuals throughout the United States.

281. On information and belief, the Dell '054 Products are provided to businesses and individuals located in the Southern District of New York.

282. By making, using, testing, offering for sale, and/or selling products and services for estimating a current motion vector for a group of pixels of an image, including but not limited to the Dell '054 Products, Dell has injured Dynamic Data and is liable to the Plaintiff for directly infringing one or more claims of the '054 patent, including at least claim 1 pursuant to 35 U.S.C. § 271(a).

283. On information and belief, Dell also indirectly infringes the '054 patent by actively inducing infringement under 35 U.S.C. § 271(b).

284. Dell has had knowledge of the '054 patent since at least service of the Original Complaint in this case or shortly thereafter, and on information and belief, Dell knew of the '054 patent and knew of its infringement, including by way of this lawsuit.

285. On information and belief, Dell intended to induce patent infringement by third-party customers and users of the Dell '054 Products and had knowledge that the inducing acts would cause infringement or was willfully blind to the possibility that its inducing acts would cause infringement. Dell specifically intended and was aware that the normal and customary use of the accused products would infringe the '054 patent. Dell performed the acts that constitute induced infringement, and would induce actual infringement, with knowledge of the '054 patent

and with the knowledge that the induced acts would constitute infringement. For example, Dell provides the Dell '054 Products that have the capability of operating in a manner that infringe one or more of the claims of the '054 patent, including at least claim 1, and Dell further provides documentation and training materials that cause customers and end users of the Dell '054 Products to utilize the products in a manner that directly infringe one or more claims of the '054 patent.¹²⁶ By providing instruction and training to customers and end-users on how to use the Dell '054 Products in a manner that directly infringes one or more claims of the '054 patent, including at least claim 1, Dell specifically intended to induce infringement of the '054 patent. On information and belief, Dell engaged in such inducement to promote the sales of the Dell '054 Products, e.g., through Dell user manuals, product support, marketing materials, and training materials to actively induce the users of the accused products to infringe the '054 patent. Accordingly, Dell has induced and continues to induce users of the accused products to use the accused products in their ordinary and customary way to infringe the '054 patent, knowing that such use constitutes infringement of the '054 patent.

286. The '054 patent is well-known within the industry as demonstrated by multiple citations to the '054 patent in published patents and patent applications assigned to technology companies and academic institutions. Dell is utilizing the technology claimed in the '054 patent without paying a reasonable royalty. Dell is infringing the '054 patent in a manner best described as willful, wanton, malicious, in bad faith, deliberate, consciously wrongful, flagrant, or characteristic of a pirate.

¹²⁶ See, e.g., *Dell G7 15, SETUP AND SPECIFICATIONS* (2018); *Alienware Graphics Amplifier, USER'S GUIDE* (2014); *Alienware Aurora R8, SETUP AND SPECIFICATIONS* (2018); *Inspiron 15 7000 Gaming, SERVICE MANUAL* (2017-2018); *XPS 13, SETUP AND SPECIFICATIONS* (2017); *Dell Latitude 5420/E5420/E5420m, OWNER'S MANUAL* (2011); *Alienware M17x R4, OWNER'S MANUAL* (2012).

287. To the extent applicable, the requirements of 35 U.S.C. § 287(a) have been met with respect to the '054 patent.

288. As a result of Dell's infringement of the '054 patent, Dynamic Data has suffered monetary damages, and seeks recovery in an amount adequate to compensate for Dell's infringement, but in no event less than a reasonable royalty for the use made of the invention by Dell together with interest and costs as fixed by the Court.

COUNT V
INFRINGEMENT OF U.S. PATENT NO. 6,774,918

289. Dynamic Data references and incorporates by reference the preceding paragraphs of this Complaint as if fully set forth herein.

290. Dell designs, makes, uses, sells, and/or offers for sale in the United States products and/or services for image processing.

291. Dell designs, makes, sells, offers to sell, imports, and/or uses Dell devices that contain H.265 decoding functionality, including but not limited to Dell desktops, laptops, projectors, and all-in-one devices, including the following exemplary models: Dell G3 3579, Dell G3 3779, Dell G5 15 5587, Dell G7 15 7588, Inspiron 14 Gaming 7466, Inspiron 14 Gaming 7467, Inspiron 15 Gaming 7566, Inspiron 15 Gaming 7567, Inspiron 15 Gaming 7577, Inspiron 5457, Inspiron 5458, Inspiron 5557, Inspiron 5558, Inspiron 5587, Inspiron 5758, Inspiron 7447, Inspiron 7460, Inspiron 7466, Inspiron 7472, Inspiron 7557, Inspiron 7559, Inspiron 7560, Inspiron 7566, Inspiron 7572, Inspiron 7588, Inspiron Desktop 3470, Inspiron Desktop 3670, Inspiron Desktop 5676, Inspiron Desktop 5680, Latitude 3190, Latitude 3190 2-in-1, Latitude 5420, Latitude 5424, Latitude 5491, Latitude 5591, Latitude 7424, Optiplex 3060, Optiplex 5060, Optiplex 5260 AIO, Optiplex 7060, Optiplex 7460 AIO, Optiplex 7760 AIO, Optiplex XE3,

Precision 3430, Precision 3430 XL Tower, Precision 3530, Precision 3630, Precision 3630 XL Tower, Precision 3930 Rack, Precision 3930 XL RACK, Precision 5510, Precision 5520, Precision 5530, Precision 7530, Precision 7730, Precision M3800, Vostro Desktop 3470, Vostro Desktop 3670, Vostro Notebook 3458, Vostro Notebook 3558, Vostro Notebook 5459, Vostro Notebook 5468, Vostro Notebook 5480, Vostro Notebook 5568, Vostro Notebook 7580, XPS 13 9360, XPS 13 9365 2-in-1, XPS 13 9370, XPS 15 9550, XPS 15 9560, XPS 15 9570, XPS 15 9575 2-in-1, XPS Desktop XPS 8930, XPS Notebook 9365, XPS Notebook 9530, XPS Notebook 9550, XPS Notebook 9560, XPS Notebook 9570, Dell Advanced Projector S718QL, Alienware 15, Alienware 15 R2-R4, Alienware 17, Alienware 17 R2-R5, Alienware 18, Alienware Area 51, Alienware Area-51 ALX, Alienware Area-51 R2-R5 & R7, Alienware Area-51 Threadripper Edition R3 & R6 & R7, Alienware Aurora, Alienware Aurora ALX, Alienware Aurora R2-R8, Alienware m15, Alienware M15x, Alienware M17x, Alienware M17x R2-R4, Alienware M18x, Alienware M18x R2, Alienware X51, and Alienware X51 R2 & R3 (collectively, the “Dell ‘918 Product(s)”).

292. The Dell ‘918 Products perform video processing compliant with the HEVC standard. *See e.g., Dell Desktop Support, DELL SUPPORT WEBSITE, available at: <https://www.dell.com/support/home/us/en/19/products/desktop>; Dell Laptop Support, DELL SUPPORT WEBSITE, available at: <https://www.dell.com/support/home/us/en/19/products/laptop>*

293. The below table shows Dell ‘918 Products that contain the infringing HEVC compliant video processing technology.

Exemplar Dell Models	Graphics Processing Unit (GPU)	HEVC Decode/Encode ¹²⁷
Dell G3 3579	NVIDIA GeForce GTX 1050 Ti ¹²⁸	Yes
Dell G3 3779	NVIDIA GeForce GTX 1060 w/ Max Q ¹²⁹	Yes
Dell G5 15 5587	NVIDIA GeForce GTX 1060 w/ Max Q ¹³⁰	Yes
Dell G7 15 7588	NVIDIA GeForce GTX 1060 w/ Max Q ¹³¹	Yes
Inspiron 14 Gaming 7466	Intel HD Graphics 530 ¹³²	Yes
Inspiron 14 Gaming 7467	Intel HD Graphics 630 ¹³³	Yes
Inspiron 15 Gaming 7566	Intel HD Graphics 530 (Integrated) / NVIDIA GeForce GTX630M (Discrete) ¹³⁴	Yes
Inspiron 15 Gaming 7567	NVIDIA GeForce GTX 1050Ti with 4GB GDDR5 / NVIDIA GeForce GTX 1050 with 4GB GDDR5 ¹³⁵	Yes
Inspiron 15 Gaming 7577	Intel HD Graphics 630 (Integrated) / NVIDIA GeForce GTX 1050/ GTX 1050 Ti/ GTX 1060 Max-Q (Discrete) ¹³⁶	Yes
Inspiron 5457	Intel HD Graphics 520 (integrated) / NVIDIA GeForce 930M (Discrete) ¹³⁷	Yes
Inspiron 5458	Intel HD Graphics 4400/4500 (integrated) / NVIDIA GeForce 920M (discrete) ¹³⁸	Yes
Inspiron 5557	Intel HD Graphics 520 (integrated) / NVIDIA GeForce 930M (discrete) ¹³⁹	Yes

¹²⁷ *NVIDIA Video Encode And Decode GPU Support Matrix*, NVIDIA DEVELOPER WEBSITE, available at: <https://developer.nvidia.com/video-encode-decode-gpu-support-matrix> (showing support for HEVC in NVIDIA Graphics cards); *Intel Product Matrix*, INTEL WEBSITE, available at: <https://www.intel.com/content/www/us/en/products> (showing HEVC Support); *Intel Graphics Product Specifications*, INTEL WEBSITE, available at: <https://www.intel.com/content/www/us/en/architecture-and-technology/visual-technology/graphics-overview.html>.

¹²⁸ *Dell Model G3 3579*, DELL WEBSITE, available at: <https://www.dell.com/en-us/work/shop/dell-laptops-and-notebooks/dell-g3-15-gaming-laptop/spd/g-series-15-3579-laptop>.

¹²⁹ *Dell Model G3 3779*, DELL WEBSITE, available at: <https://www.dell.com/en-us/shop/dell-laptops/dell-g3-17-gaming/spd/g-series-17-3779-laptop>.

¹³⁰ *Dell Model G5 15 5587*, DELL WEBSITE, available at: <https://www.dell.com/en-us/shop/dell-laptops/dell-g5-15-gaming/spd/g-series-15-5587-laptop>.

¹³¹ *Dell Model G7 15 7588*, DELL WEBSITE, available at: <https://www.dell.com/en-us/shop/dell-laptops/dell-g7-15-gaming/spd/g-series-15-7588-laptop>.

¹³² *Dell Inspiron 14 Gaming Setup and Specifications*, DELL MANUAL MODEL NO. INSPIRON 14-7466 at 18 (2016).

¹³³ *Dell Inspiron 14 7000 Gaming Series Setup and Specifications*, DELL SPECIFICATIONS MODEL NO. INSPIRON 14-7467 at 18 (2016).

¹³⁴ *Dell Inspiron 15 Gaming Setup and Specifications*, DELL MANUAL MODEL NO. 15-7566 at 18 (2016).

¹³⁵ *Dell Inspiron Model 7567*, DELL WEBSITE, available at: <https://www.dell.com/us/dfh/p/inspiron-15-7567-laptop/pd>.

¹³⁶ *Dell Inspiron 15 7000 Gaming Setup and Specifications*, DELL MANUAL MODEL NO. INSPIRON 15-7577 at 23 (2018).

¹³⁷ *Dell Inspiron 14 5000 Series Specification*, DELL SPECIFICATIONS MODEL NO. INSPIRON 14-5457 at 12 (2015).

¹³⁸ *Dell Inspiron 14 5000 Series Specification*, DELL SPECIFICATIONS MODEL NO. INSPIRON 14-5458 at 12 (2015).

¹³⁹ *Dell Inspiron 14 5000 Series Specification*, DELL SPECIFICATIONS MODEL NO. INSPIRON 14-5557 at 12 (2015).

Inspiron 5558	Intel HD Graphics 4400/4500 (integrated) / NVIDIA GeForce 920M (discrete) ¹⁴⁰	Yes
Inspiron 5587	NVIDIA GeForce GTX 1060 Max-Q ¹⁴¹	Yes
Inspiron 5758	Intel HD Graphics 4400/4500 (integrated) / NVIDIA GeForce 920M (discrete) ¹⁴²	Yes
Inspiron 7447	Intel Iris Pro Graphic 5200 (integrated) / NVIDIA GeForce GTX 850M (discrete) ¹⁴³	Yes
Inspiron 7460	Intel HD Graphics 610/620/635 (integrated)/ NVIDIA GeForce 940M ¹⁴⁴	Yes
Inspiron 7466	Intel HD Graphics 530 (integrated) / NVIDIA GeForce GTX 950M ¹⁴⁵	Yes
Alienware Area 51	NVIDIA GeForce RTX 2080 Ti OC with 11GB GDDR6 ¹⁴⁶	Yes
Alienware Area-51 R2	NVIDIA® GeForce GTX ¹⁴⁷	Yes
Alienware Area-51 R4/R5	NVIDIA® GeForce GTX ¹⁴⁸	Yes
Alienware Area-51 Threadripper R3/R6	NVIDIA GeForce GTX 1080 ¹⁴⁹	Yes
Alienware Area-51 Threadripper Edition R7	Dual NVIDIA® GeForce® RTX 2080 Ti OC ¹⁵⁰	Yes
Alienware Aurora	NVIDIA® GeForce® RTX 2080 Ti OC with 11GB GDDR6 ¹⁵¹	Yes

294. Dell documentation states that the Dell ‘918 Products are compliant with the HEVC standard as shown in the following excerpts.

¹⁴⁰ *Dell Inspiron 14 5000 Series Specification*, DELL SPECIFICATIONS MODEL NO. INSPIRON 14-5558 at 12 (2015).

¹⁴¹ *Dell Inspiron Model 5587*, DELL WEBSITE, available at: <https://www.dell.com/en-us/shop/dell-laptops/dell-g5-15-gaming/spd/g-series-15-5587-laptop>.

¹⁴² *Dell Inspiron 17 5000 Series Specification*, DELL SPECIFICATIONS MODEL NO. INSPIRON 17-5758 at 12 (2015).

¹⁴³ *Dell Inspiron 14 7000 Series Specification*, DELL SPECIFICATIONS MODEL NO. INSPIRON 7447 at 12 (2014).

¹⁴⁴ *Dell Inspiron 14 7000 Setup and Specification*, DELL MANUAL MODEL NO. INSPIRON 14-7460 at 18 (2018).

¹⁴⁵ *Dell Inspiron 14 Gaming Setup and Specifications*, DELL MANUAL MODEL NO. INSPIRON 14-7466 at 18 (2016).

¹⁴⁶ *Dell Alienware Specifications*, DELL WEBSITE, available at: <https://www.dell.com/en-us/shop/dell-desktop-computers/alienware-area-51/spd/alienware-area51-r5>.

¹⁴⁷ *Dell Alienware Specifications*, DELL WEBSITE, available at: <https://www.dell.com/en-us/shop/cty/pdp/spd/alienware-area51-r2>.

¹⁴⁸ *Dell Alienware Specifications*, DELL WEBSITE, available at: <https://www.dell.com/en-us/shop/dell-desktop-computers/alienware-area-51-gaming-desktop/spd/alienware-area51-r4>.

¹⁴⁹ *Dell Alienware Specifications*, DELL WEBSITE, available at: <https://www.dell.com/en-us/shop/dell-desktop-computers/alienware-area-51-threadripper-edition/spd/alienware-area51-r6>.

¹⁵⁰ *Dell Alienware Specifications*, DELL WEBSITE, available at: <https://www.dell.com/en-us/shop/desktops/area-51-threadripper/spd/alienware-area51-r7>.

¹⁵¹ *Dell Alienware Specifications*, DELL WEBSITE, available at: <https://www.dell.com/en-us/shop/dell-desktop-computers/alienware-aurora/spd/alienware-aurora-r7-desktop>.

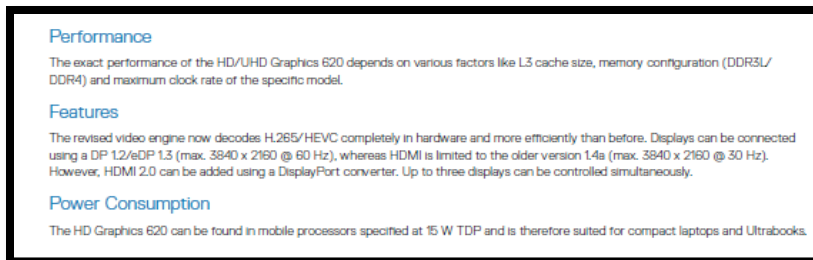

DELL LATITUDE 5420 RUGGED OWNER’S MANUAL at 44 (2015) (“The revised video engine now decodes H.265/HEVC completely in hardware and more efficiently than before.”).

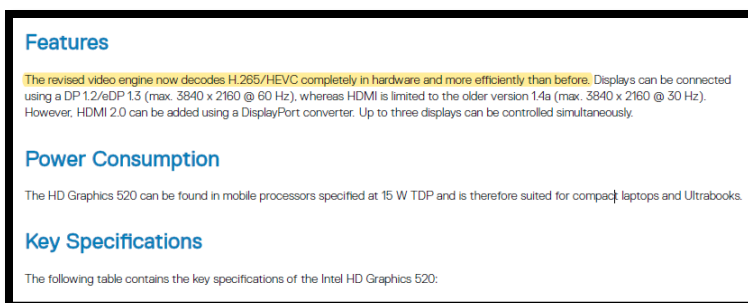

DELL VOSTRO 14-3468 OWNER’S MANUAL at 55 (2018) (annotation added) (“The revised video engine now decodes H.265/HEVC completely in hardware and more efficiently than before.”).



DELL PRODUCT QUICK REFERENCE MATRIX Q4 2018 at 17 (2018) (“New HEVC 10-bit and VP9 decode”).

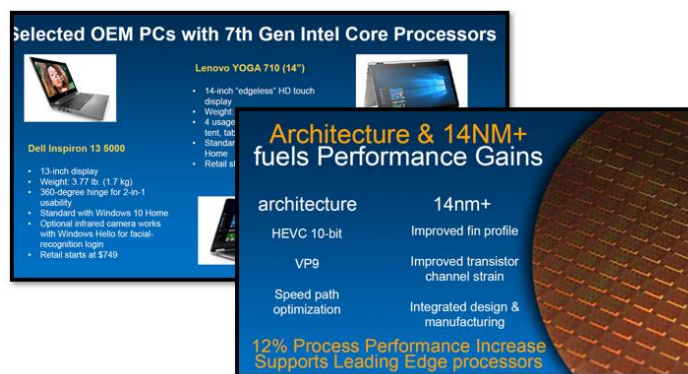

David Bradshaw, 7th Generation Intel Core Processor, INTEL PRESENTATION at 3 & 12 (2016).

295. On information and belief, the Dell ‘918 Products contain functionality for downloading on-screen display (OSD) data for generating an image on a display device. Specifically, the Dell Products have an input for receiving frame-based encoded video information. The Dell Products receive frame-based encoded video information in the form of video data that is encoded in the High Efficiency Video Coding (HEVC/H.265) format set by the ITU-T Video Coding Experts Group

296. On information and belief, by complying with the HEVC standard, the Dell devices – such as the Dell ‘918 Products – necessarily infringe the ‘918 patent. Mandatory sections of the HEVC standard require the elements required by certain claims of the ‘918 patent, including but not limited to claim 18. *High Efficiency Video Coding*, SERIES H: AUDIOVISUAL AND Multimedia SYSTEMS: INFRASTRUCTURE OF AUDIOVISUAL SERVICES – CODING OF MOVING VIDEO REC. ITU-T H.265 (February 2018). The following sections of the HEVC Standard are relevant to Dell’s infringement of the ‘918 patent: “5.3 Logical operators;” “5.10 Variables, syntax elements and tables;” “5.11 Text description of logical operations;” “7.2 Specification of syntax functions and descriptors;” “7.3.1 NAL unit syntax;” “7.3.2 Raw byte sequence payloads, trailing bits and byte alignment syntax;” “7.3.5 Supplemental enhancement information message syntax;” “7.4.2 NAL unit semantics;” and “7.4.6 Supplemental enhancement information message semantics.”

297. On information and belief, the Dell ‘918 Products receive a bitstream in which the data is segmented into Network Abstraction Layer (“NAL”) Units. NAL Units are segments of data that can include video data and overlay data (such as captions and overlay images). The Dell Products support the receipt of VCL and non-VCL NAL units. The VCL NAL units contain the data that represents the values of the samples in the video pictures, and the non-VCL NAL units contain any associated additional information such as parameter sets or overlay data.

HEVC uses a NAL unit based bitstream structure. A coded bitstream is partitioned into NAL units which, when conveyed over lossy packet networks, should be smaller than the maximum transfer unit (MTU) size. Each NAL unit consists of a NAL unit header followed by the NAL unit payload. There are two conceptual classes of NAL units. Video coding layer (VCL) NAL units containing coded sample data, e.g., coded slice NAL units, whereas non-VCL NAL units that contain metadata typically belonging to more than one coded picture, or where the association with a single coded picture would be meaningless, such as parameter set NAL units, or where the information is not needed by the decoding process, such as SEI NAL units.

Rickard Sjöberg et al, *Overview of HEVC High-Level Syntax and Reference Picture Management*, IEEE TRANSACTIONS ON CIRCUITS AND SYSTEMS FOR VIDEO TECHNOLOGY, Vol. 22, No. 12 at 1859 (December 2012) (emphasis added).

298. On information and belief, the VCL NAL Units contain segments of data which are used to generate an image (e.g., HEVC image) on a display device. Each VCL NAL Unit comprises a discrete number of bites which make up a segment. The following excerpt from the HEVC specification describes the NAL unit as being a segment with a “demarcation” setting forth where the segment ends and begins.

NumBytesInNalUnit specifies the size of the NAL unit in bytes. This value is required for decoding of the NAL unit. Some form of demarcation of NAL unit boundaries is necessary to enable inference of NumBytesInNalUnit. One such demarcation method is specified in Annex B for the byte stream format. Other methods of demarcation may be specified outside of this Specification.

High Efficiency Video Coding, Series H: Audiovisual And Multimedia Systems: Infrastructure Of Audiovisual Services – Coding Of Moving Video Rec. ITU-T H.265 at § 7.4.2.1 (February 2018) (emphasis added).

299. On information and belief, VCL NAL Units comprise discrete video data that ends. It is between the receipt of VCL NAL Units that the overlay data (Non-VCL NAL Unit) data is received by the Dell Products.

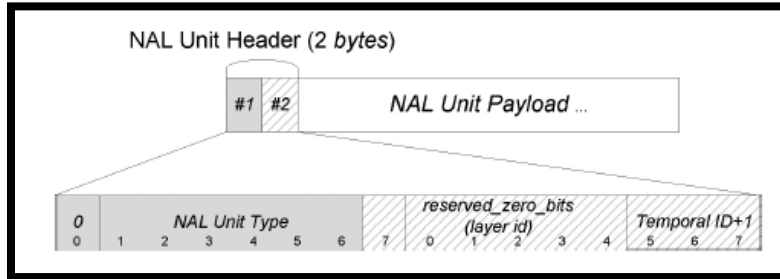

Thomas Schierl, Miska M. Hannuksela, Ye-Kui Wang, and Stephan Wenger, System Layer Integration of High Efficiency Video Coding, *IEEE TRANS. CIR. AND SYS. FOR VIDEO TECHNOLOGY*, VOL. 22, NO. 12 at 1875 (December 2012).

300. On information and belief, the HEVC bitstream structure is comprised of discreet data. In the gaps between the receipt by the Dell ‘918 Products of VCL NAL Units Non-VCL NAL Units are received by the Dell Products’ decoder.

An HEVC bitstream consists of a number of access units, each including coded data associated with a picture that has a distinct capturing or presentation time. Each access unit is divided into NAL units, including one or more VCL NAL units (i.e., coded slice NAL units) and zero or more non-VCL NAL units, e.g., parameter set NAL units or supplemental enhancement information (SEI) NAL units. Each NAL unit includes an NAL unit header and an NAL unit payload. Information in the NAL unit header can be (conveniently) accessed by media gateways, also known as media aware network elements (MANEs), for intelligent, media aware operations on the stream, such as stream adaptation.

Thomas Schierl, Miska M. Hannuksela, Ye-Kui Wang, and Stephan Wenger, System Layer Integration of High Efficiency Video Coding, *IEEE TRANS. CIR. AND SYS. FOR VIDEO TECHNOLOGY*, VOL. 22, NO. 12 at 1873 (December 2012).

301. On information and belief, Non-VCL NAL unit types include data such as supplemental enhancement information that is used to create overlays for display on the device.

Table 2.2 The 32 HEVC non-VCL NAL unit types

Non-VCL NAL unit types			
Parameter sets	32	VPS_NUT	Video parameter set
	33	SPS_NUT	Sequence parameter set
	34	PPS_NUT	Picture parameter set
Delimiters	35	AUD_NUT	Access unit delimiter
	36	EOS_NUT	End of sequence
	37	EOB_NUT	End of bitstream
Filler data	38	FD_NUT	Filler data
Supplemental enhancement information (SEI)	39	PREFIX_SEI_NUT	
	40	SUFFIX_SEI_NUT	
Reserved	41–47	RSV	
Unspecified	48–63	UNSPEC	

Gary J. Sullivan et al, HIGH EFFICIENCY VIDEO CODING (HEVC) at 29 (September 2014).

302. On information and belief, Non-VCL NAL Units include supplemental enhancement information (“SEI”) messages. The SEI data that is received contains overlay information that can be combined with the image data that has already been received.

sei_message() {	Descriptor
payloadType = 0	
while(next_bits(8) == 0xFF) {	
ff_byte /* equal to 0xFF */	f(8)
payloadType += 255	
}	
last_payload_type_byte	u(8)
payloadType += last_payload_type_byte	
payloadSize = 0	
while(next_bits(8) == 0xFF) {	
ff_byte /* equal to 0xFF */	f(8)
payloadSize += 255	
}	
last_payload_size_byte	u(8)
payloadSize += last_payload_size_byte	
sei_payload(payloadType, payloadSize)	
}	

High Efficiency Video Coding, Series H: Audiovisual And Multimedia Systems: Infrastructure Of Audiovisual Services – Coding Of Moving Video Rec. ITU-T H.265 at § 7.3.5 (February 2018).

303. On information and belief, the Dell ‘918 Products combine the VCL NAL Unit and Non-VCL NAL Unit information to create images that contain overlay information.

The NAL units are decoded by the decoder to produce the decoded pictures that are output from the decoder. Both the encoder and decoder store pictures in a decoded picture buffer (DPB). This buffer is mainly used for storing pictures so that previously coded pictures can be used to generate prediction signals to use when coding other pictures. These stored pictures are called reference pictures. . . . There are two classes of NAL units in HEVC—video coding layer (VCL) NAL units and non-VCL NAL units. Each VCL NAL unit carries one slice segment of coded picture data while the non-VCL NAL units contain control information that

typically relates to multiple coded pictures. One coded picture, together with the non-VCL NAL units that are associated with the coded picture, is called an HEVC access unit.

Gary J. Sullivan et al, HIGH EFFICIENCY VIDEO CODING (HEVC) at 14-15 (September 2014) (emphasis added).

304. On information and belief, one or more Dell subsidiaries and/or affiliates use the Dell '918 Products in regular business operations.

305. On information and belief, the Dell '918 Products are available to businesses and individuals throughout the United States.

306. On information and belief, the Dell '918 Products are provided to businesses and individuals located in the Southern District of New York.

307. By making, using, testing, offering for sale, and/or selling products and services, including but not limited to the Dell '918 Products, Dell has injured Dynamic Data and is liable for directly infringing one or more claims of the '918 patent, including at least claim 18, pursuant to 35 U.S.C. § 271(a).

308. On information and belief, Dell also indirectly infringes the '918 patent by actively inducing infringement under 35 U.S.C. § 271(b).

309. On information and belief, Dell has had knowledge of the '918 patent since at least service of the Original Complaint in this case or shortly thereafter, and on information and belief, Dell knew of the '918 patent and knew of its infringement, including by way of this lawsuit.

310. On information and belief, Dell intended to induce patent infringement by third-party customers and users of the Dell '918 Products and had knowledge that the inducing acts would cause infringement or was willfully blind to the possibility that its inducing acts would cause infringement. Dell specifically intended and was aware that the normal and customary use of the accused products would infringe the '918 patent. Dell performed the acts that constitute

induced infringement, and would induce actual infringement, with knowledge of the '918 patent and with the knowledge that the induced acts would constitute infringement. For example, Dell provides the Dell '918 Products that have the capability of operating in a manner that infringe one or more of the claims of the '918 patent, including at least claim 18, and Dell further provides documentation and training materials that cause customers and end users of the Dell '918 Products to utilize the products in a manner that directly infringe one or more claims of the '918 patent.¹⁵² By providing instruction and training to customers and end-users on how to use the Dell '918 Products in a manner that directly infringes one or more claims of the '918 patent, including at least claim 18, Dell specifically intended to induce infringement of the '918 patent. On information and belief, Dell engaged in such inducement to promote the sales of the Dell '918 Products, e.g., through Dell user manuals, product support, marketing materials, and training materials to actively induce the users of the accused products to infringe the '918 patent. Accordingly, Dell has induced and continues to induce users of the accused products to use the accused products in their ordinary and customary way to infringe the '918 patent, knowing that such use constitutes infringement of the '918 patent.

311. The '918 patent is well-known within the industry as demonstrated by multiple citations to the '918 patent in published patents and patent applications assigned to technology companies and academic institutions. Dell is utilizing the technology claimed in the '918 patent without paying a reasonable royalty. Dell is infringing the '918 patent in a manner best described

¹⁵² See, e.g., *Alienware Graphics Amplifier*, USER'S GUIDE (2014); *Inspiron 15 7000 Gaming*, SERVICE MANUAL (2017-2018); *XPS 15*, SERVICE MANUAL (2018); *Dell Optiplex 5060 Micro*, SETUP AND SPECIFICATIONS GUIDE (2018); *Dell Latitude E7470*, OWNER'S MANUAL (2016); *Dell G7 15*, SETUP AND SPECIFICATIONS (2018); *Alienware Graphics Amplifier*, USER'S GUIDE (2014); *XPS 13*, SETUP AND SPECIFICATIONS (2017); *Dell Precision Mobile Workstation M4800*, OWNER'S MANUAL (2015); *Dell Precision Tower 5810*, OWNER'S MANUAL (2017); *Dell Canvas 27*, USER'S GUIDE (2017).

as willful, wanton, malicious, in bad faith, deliberate, consciously wrongful, flagrant, or characteristic of a pirate.

312. To the extent applicable, the requirements of 35 U.S.C. § 287(a) have been met with respect to the '918 patent.

313. As a result of Dell's infringement of the '918 patent, Dynamic Data has suffered monetary damages, and seeks recovery in an amount adequate to compensate for Dell's infringement, but in no event less than a reasonable royalty for the use made of the invention by Dell together with interest and costs as fixed by the Court.

COUNT VI
INFRINGEMENT OF U.S. PATENT NO. 8,184,689

314. Dynamic Data references and incorporates by reference the preceding paragraphs of this Complaint as if fully set forth herein.

315. Dell designs, makes, uses, sells, and/or offers for sale in the United States products and/or services for encoding and decoding video data.

316. Dell designs, makes, sells, offers to sell, imports, and/or uses Dell desktops, laptops, and all-in-one devices, including but not limited to the following exemplary models: Dell G3 3579, Dell G3 3779, Dell G5 15 5587, XPS 15 9570, XPS 15 9575 2-in-1, XPS 15 9560, Inspiron 15 Gaming 7566, Inspiron 15 Gaming 7567, Inspiron 15 Gaming 7577, Inspiron 14 Gaming 7466, Inspiron 14 Gaming 7467, XPS 15 9550, Adamo 13, Adamo XPS, Alienware Alpha & Alienware Steam Machine, Alienware Alpha R2 & Alienware Steam Machine R2, Alienware Area 51, Alienware Area-51 ALX, Alienware Area-51 R2, Alienware Area-51 R4 and R5, Alienware Area-51 Threadripper Edition R3 and R6, Alienware Area-51 Threadripper Edition R7, Alienware Aurora, Alienware Aurora ALX, Alienware Aurora R2, Alienware Aurora R3, Alienware Aurora

R4, Alienware Aurora R5, Alienware Aurora R6, Alienware Aurora R7, Alienware Aurora R8, Alienware X51, Alienware X51 R2, Alienware X51 R3, Alienware 15 R4, Alienware M17x, Alienware 17, Alienware M17x R2, Alienware 17 R2, Alienware M17x R3, Alienware 17 R3, Alienware M17x R4, Alienware 15, Alienware 17 R4, Alienware M18x, Alienware 15 R2, Alienware 17 R5, Alienware m15, Alienware M18x R2, Alienware 15 R3, Alienware 18, Alienware M15x, Dell G7 15 7588, XPS 13 9370, XPS 13 9360, and XPS 13 9365 2-in-1 (collectively, the “Dell ‘689 Product(s)”).

317. The Dell ‘689 Products use Intel processors with integrated graphics processors including the following graphics processors: Intel UHD Graphics 630, Integrated GPU HD Cherry Trail, Integrated GPU HD 4200, Integrated GPU HD 4400, Integrated GPU HD 5000, Integrated GPU HD515, Integrated GPU HD520, Integrated GPU HD540, Integrated GPU HD 615, Integrated GPU HD 620, and Integrated GPU Iris Plus 640.

318. The Graphics Processing Units (“GPUs”) in the Dell ‘689 Products perform motion compensation as part of the video decoding process. Specifically, the following evidence establishes that the Dell ‘689 Products perform motion compensated image processing using the GPU.

Motion compensation is the term for an important stage of the decoding process for compressed digital video. Many graphic accelerator devices provide some type of acceleration capability for supporting compressed video decoding. Because the motion compensation process is the most frequently supported part of video decoding, the device driver interface that supports compressed video decoding is called the motion compensation DDI. In addition to motion compensation, some devices can perform IDCT (Inverse Discrete Cosine Transformation) and other hardware functions that a software video decoder can use to accelerate the decoding process. The motion compensation DDI is flexible enough to handle devices that provide these other capabilities as well.

Windows Hardware – Motion Compensation, MICROSOFT HARDWARE DOCUMENTATION (April 19, 2017), available at: <https://docs.microsoft.com/en-us/windows-hardware/drivers/display/motion-compensation>.

319. Further, documentation relating to the hardware in the Dell ‘689 Products describes block based “motion compensated prediction” as being “what gives the . . . H.25x family of codes the advantage over still-frame coding methods.” Further, “[i]n motion-compensated prediction, previously transmitted and decoded data serves as the prediction for current data.”

Block motion-compensated prediction (MCP) is the type of prediction implemented by DirectX VA. This prediction type is what gives the MPEG and H.26x family of codecs the advantage over pure still-frame coding methods, such as JPEG. Types of motion-compensated prediction other than block-based prediction are not implemented by DirectX VA.

In motion-compensated prediction, previously transmitted and decoded data serves as the prediction for current data. The difference between the prediction and the actual current data values is the prediction error. The coded prediction error is added to the prediction to obtain the final representation of the input data. After the coded prediction error is added to the MCP, the final decoded picture is used in the MCP to generate subsequent coded pictures.

Motion-Compensated Prediction, WINDOWS HARDWARE DEV CENTER DOCUMENTATION (April 19, 2017), available at: <https://docs.microsoft.com/en-us/windows-hardware/drivers/display/motion-compensated-prediction>.

320. The Dell ‘689 Products perform motion compensated image processing using the H.265/HEVC decoding which is incorporated into the graphics processing units of each product. Further, the infringing Dell ‘689 Products encompass an image processing component that enables the storing in memory of video frames including at least a first and second frame. For example, the Dell ‘689 Products contain storage for the first input image and second input image. The storage includes the L1 or L2 Cache. The below diagram shows that how the L2 Cache is a storage device connected to the graphic processing unit (Gen8-LP).

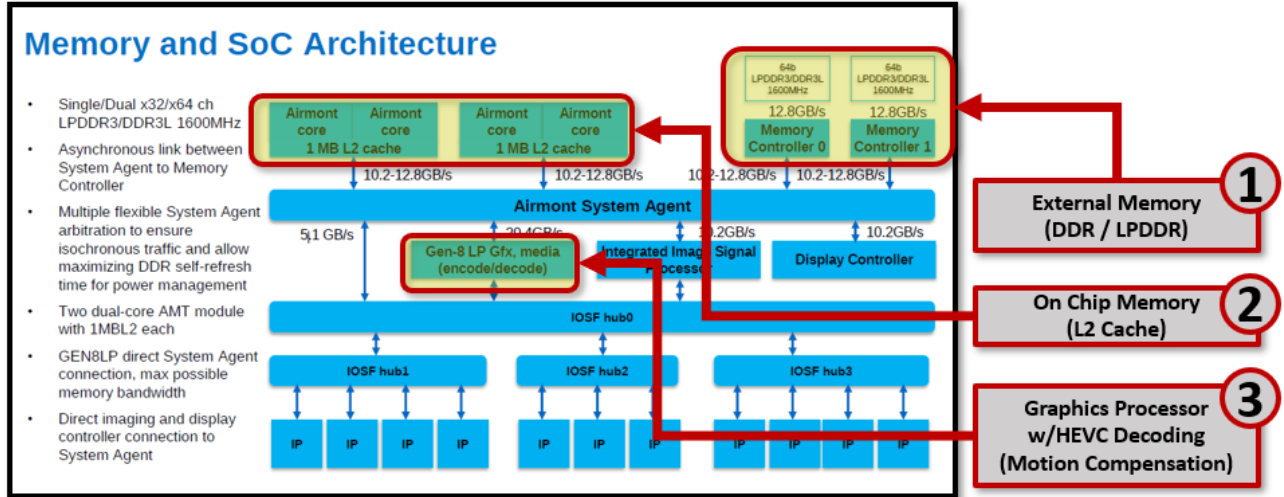

Steven Tu, Atom -x5/x7 Series Processor, Codenamed Cherry Trail, INTEL PRESENTATION at 6 (2015) (annotations added).

321. The Dell ‘689 Products contain functionality for motion compensation where two or more motion vectors can be applied. Further, one or two motion vectors can be applied to the image processing process. The application of the motion vectors leads to uni-predictive or bi-predictive coding, respectively, where bi-predictive coding uses an averaged result of two predictions to form the final prediction as shown in the below excerpt from the International Telecommunication Union (“ITU”) H.265 Standard.

Summary

Recommendation ITU-T H.265 | International Standard ISO/IEC 23008-2 represents an evolution of the existing video coding Recommendations (ITU-T H.261, ITU-T H.262, ITU-T H.263 and ITU-T H.264) and was developed in response to the growing need for higher compression of moving pictures for various applications such as Internet streaming, communication, videoconferencing, digital storage media and television broadcasting. It is also designed to enable the use of the coded video representation in a flexible manner for a wide variety of network environments. The use of this Recommendation | International Standard allows motion video to be manipulated as a form of computer data and to be stored on various storage media, transmitted and received over existing and future networks and distributed on existing and future broadcasting channels.

High Efficiency Video Coding, SERIES H: AUDIOVISUAL AND MULTIMEDIA SYSTEMS: INFRASTRUCTURE OF AUDIOVISUAL SERVICES – CODING OF MOVING VIDEO REC. ITU-T H.265 at § I (February 2018).

322. As shown below the Dell ‘689 Products perform motion compensated image processing using Intel’s 7.5, 8, and 9th Generation Graphics Processing Technology (collectively, “Intel Processor Graphics”). Intel Processor Graphics perform decoding using nearly identical functionality and technologies. For example, The Intel 7.5, 8, and 9th Generation Graphics Processors contain: (1) on processor memory for storing and retrieval of motion vectors (L1 Cache, L2 Cache, L3 Cache and Data Port); (2) a System-on-Chip Ring Interconnect that allows for the rapid retrieval and storage of motion vector data on memory structures that are external to the Graphics Processor (LLC Cache, DRAM, EDRAM).

323. The Dell ‘689 Products perform a method for encoding and decoding a video stream wherein the graphic processor is connected to a first and second memory. For example, during the decoding process the image processing unit stores vectors and reference frames on the image processor and stores and retrieves vectors and reference frames externally from the system DRAM. The image processor itself can read and write vectors to the L1 Cache, L2 Cache, or Data Port. The data port supports efficient read/write operations for a variety of general-purpose buffer accesses, flexible SIMD scatter/gather operations, as well as shared local memory access.

Within Intel processor graphics, the data port unit, the L3 data cache, and GTI have all been upgraded to support a new globally coherent memory type. Reads or writes originating from Intel processor graphics to memory typed as globally coherent drive Intel VT-d specified snooping protocols to ensure data integrity with any CPU core cached versions of that memory. Conversely, any reads or writes that originate from the CPU cores against globally coherent memory, will drive snooping protocols against gen8’s L3 cache.

THE COMPUTE ARCHITECTURE OF INTEL PROCESSOR GRAPHICS GEN8 at 9 (July 15, 2015) (emphasis added).

324. The below diagram shows a view of the SoC chip level memory hierarch that is in the Dell ‘689 Products. The annotations identify the location of the external memory where vectors

can be retrieved and stored (DRAM) as well as the on-chip location (motion estimation function) where vectors can be retrieved from by the motion compensation unit.

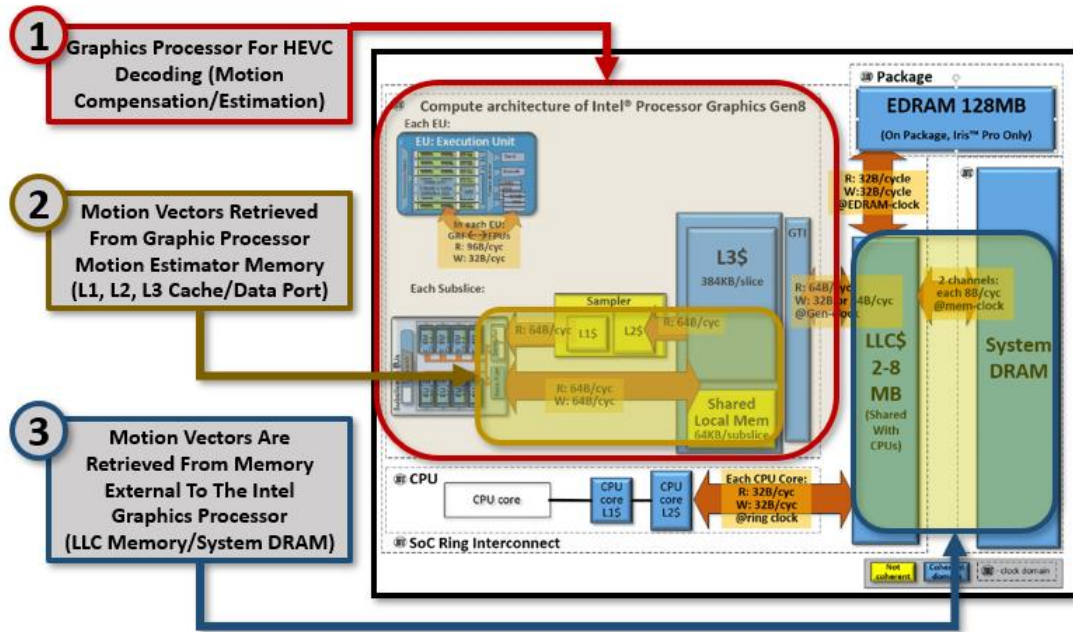

THE COMPUTE ARCHITECTURE OF INTEL PROCESSOR GRAPHICS GEN8 at 15 (July 15, 2015) (annotations added).

325. The Dell ‘689 Products perform the step of providing a subset of image data stored in the second memory in the first memory. For example, the Dell ‘689 products contain system on chip memory including an L1 Cache, L2 Cache and Data Port. The data port is a memory load/store unit that supports efficient read/write operations for a variety of general-purpose buffer accesses, “flexible SIMD scatter/gather operations, as well as shared local memory access. To maximize memory bandwidth, the unit also dynamically coalesces scattered memory operations into fewer operations over non-duplicated 64-byte cache line requests.” THE COMPUTE ARCHITECTURE OF INTEL® PROCESSOR GRAPHICS GEN7.5 at 8 (August 2014) (annotation added).

326. The Dell ‘689 Products contain several memory structures that are used as storage units for storing a first input and second input image as part of the image processing performed by the graphics processing unit.

2.3. Memory

Graphics resources that are allocated from system memory with write-back caching will utilize the full cache hierarchy: Level 1 (L1), Level 2 (L2), last-level cache (LLC), optional EDRAM, and finally DRAM. When accessed from the GPU, sharing can occur in LLC and further caches/memory. The Intel® Processor Graphics Gen9 GPU has numerous bandwidth improvements including increased LLC and ring bandwidth. Coupled with support for DDR4 RAM, these help hide latency.

Graphics API Performance Guide Version 2.5, INTEL DOCUMENTATION at 8 (November 29, 2017), available at: <https://software.intel.com/en-us/documentation/graphics-api-performance-guide-for-intel-processor-graphics-gen9>.

327. The Dell ‘689 products contain a GPU memory interface that places a first and second input image into a memory structure for storage. The below excerpt from Intel’s documentation describes that as part of the decoding process a HEVC Codec Pipeline (“HCP”) is used. The HCP is a fixed function hardware video codec responsible for decoding HEVC video streams. As part of the process of decoding two or more reference pictures are retrieved from a memory structure on the Dell ‘689 Product.

HCP Command Summary

The HCP is configured for decoding through a set of batch commands defined in the following sections. The software driver builds a frame level workload using these commands and stores these workloads in graphics memory where they are fetched by the Video Command Streamer (VCS) and presented to the HCP for processing. The commands are processed by the Workload Parser within the HCP and the hardware is configured by the Workload Parser prior to each frame level encode or decode. A workload is defined as a set of commands necessary to encode or decode one frame.

INTEL OPEN SOURCE HD GRAPHICS PROGRAMMERS’ REFERENCE MANUAL (PRM) VOL. 10: HIGH EFFICIENCY VIDEO CODING at 3 (June 2015).

328. The Dell ‘689 Products perform the step of simultaneously encoding and decoding of more than one image of a video stream by accessing a subset of the image data and sharing access to at least one image. For example, the first and second images that are used in the decoding process are stored on the Dell ‘689 Products and accessed via the GPU Memory interface. The memory interface controls where in memory motion vectors, video frames, and other data are

stored. “The Memory Interface function provides access to graphics memory (GM) clients. It accepts memory addresses of various types, performs a number of optional operations along *address paths*, and eventually performs reads and writes of graphics memory data using the resultant addresses.” INTEL OPEN SOURCE HD GRAPHICS PROGRAMMERS’ REFERENCE MANUAL (PRM) VOL. 5: MEMORY VIEWS at 4 (June 2015). Further, the Dell ‘689 Products enable the retrieval of a first and second stored image using the HCP_PIPE_BUF_ADDR_STATE media instruction command. This command and others identify the location of the stored image so that it can be retrieved by the graphics processing unit. The below excerpt from Intel documentation shows the memory address attributes associated with a stored image.

The Location In Memory Of An Image Stored On The Microsoft Surface Product In A Memory Structure

HCP_PIPE_BUF_ADDR_STATE			
34..35	63:0	Reserved	
		Format:	MBZ
36	31:0	Reserved	
		Project:	CHV, BSW
		Format:	MBZ
37..52	63:0	Reference Picture Base Address (RefAddr[0-7])	
		Format:	SplitBaseAddress:64ByteAligned[8]
		Base address of the reference picture buffer.	
		Programming Notes	
		Must be 4k byte aligned.	
53	31:0	Reference Picture Base Address Memory Address Attributes	
		Project:	CHV, BSW
		Format:	MemoryAddressAttributes [CHV, BSW]
54..59	31:0	Reserved	
60..61	63:0	Reserved	
		Project:	CHV, BSW
62	31:0	Reserved	

INTEL OPEN SOURCE HD GRAPHICS PROGRAMMER REFERENCE MANUAL (PRM) VOL. 2A: COMMAND REFERENCE INSTRUCTIONS (COMMAND OPCODES) at 427 (June 2015) (annotations added).

329. The following slide from an excerpt from an Intel presentation relating to the graphics processing unit that is including in the Dell ‘689 Products shows how the memory controller act as the interface between the graphics processor and memory structures including caches and off-chip memory.

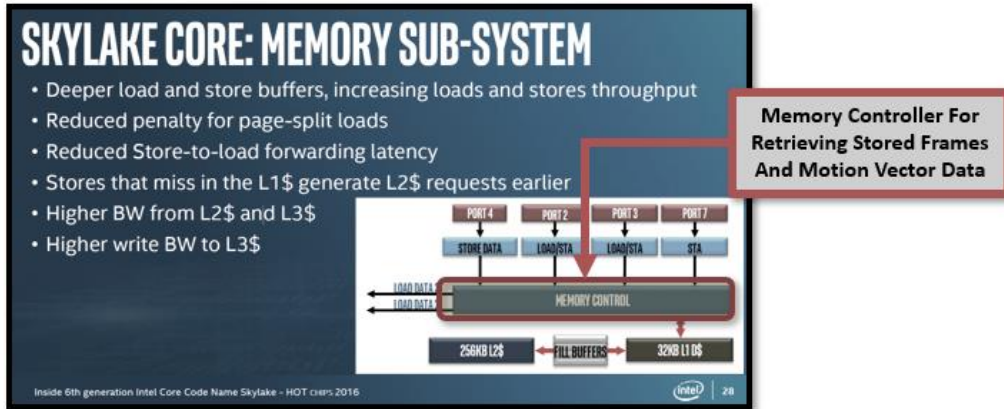

Jack Doweck, *Inside 6th Gen. Intel Core: New Microarchitecture Code Named Skylake*, INTEL PRESENTATION at 28 (2016) (annotation added).

330. The Dell ‘689 Products contain functionality as documented in the Intel graphic processing unit command reference instructions that shows that two reference pictures (e.g., a first and second input image) can be used by the motion compensation unit to generate an output image using a further motion vector field. For example, the documentation relating to the HCP_REF_IDX_STATE command shows that two reference pictures can be used to generate a further output image.

Microsoft Surface GPU Command Instructions Showing Using The First And Second Reference Picture To Generate A Motion Vector

10:8	list_entry_IX[i]: Reference Picture Frame ID (RefAddr[0-7]) Format: U3 Where X is the RefPicListNum and i is the list entry number 0 through 15. DW2 corresponds to i=0, DW17 corresponds to i=15. The reference picture frame ID identifies the reference picture associated with the base address defined in Reference Picture Address (RefAddr[0-7]) in the HCP_PIPE_BUF_ADDR_STATE command.
7:0	list_entry_IX[i]: Reference Picture tb Value Format: U8 Where X is the RefPicListNum and i is the list entry number 0 through 15. DW2 corresponds to i=0, DW17 corresponds to i=15. clip(-128,127, CurrentPOC - RefPOC), where RefPOC is the POC value of the reference picture. 8-bit signed. See the "Derivation process for temporal luma motion vector prediction" in the HEVC standard.

INTEL OPEN SOURCE HD GRAPHICS PROGRAMMER REFERENCE MANUAL (PRM) VOL. 2A: COMMAND REFERENCE INSTRUCTIONS (COMMAND OPCODES) at 440, 482 (June 2015) (annotations added) (“Unlike AVC, HEVC allows 16 reference idx entries in each of the L0 and L1 list for a progressive picture. Hence, a max total 32 reference idx in both lists together. The same when the picture is a field picture. Regardless the number of reference idx entries, there are

only max 8 reference pictures exist at any one time. Multiple reference idx can point to the same reference picture and can optionally pic a top or bottom field, or frame.”).

331. The Dell ‘689 Products contain functionality for retrieving a image data stored in a second memory (e.g., memory located off the graphics processing unit) for use in generating a further image/frame using motion compensation. Specifically, the infringing Dell ‘689 Products contain functionality wherein the calculation of a further frame in a video is generated from the stored first and second images and a motion vector retrieved from the motion estimation unit. The below excerpt from Intel documentation shows a command instruction from documentation relating to the Dell ‘689 Products’ GPUs where a motion vector can be retrieved for motion compensation image processing at the base address for the Collocated Motion Vector Temporal Buffer. The location of the vector can be on the LLC Cache, or DRAM).

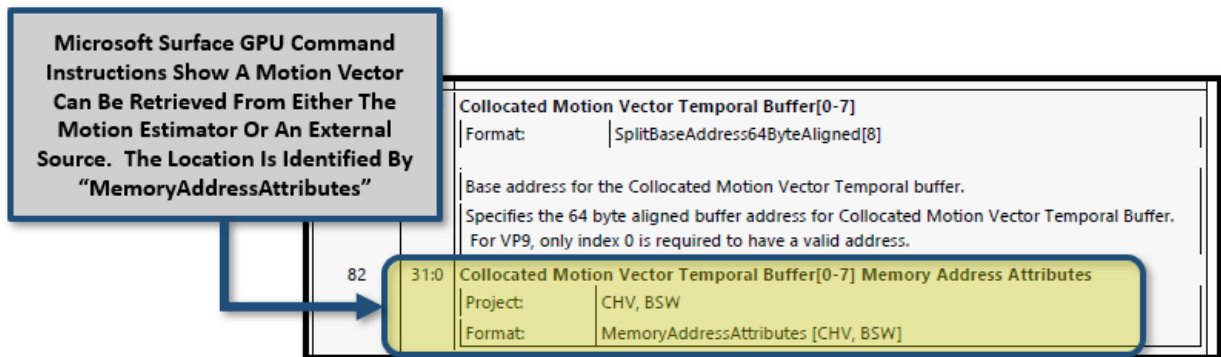

INTEL OPEN SOURCE HD GRAPHICS PROGRAMMER REFERENCE MANUAL (PRM) VOL. 2A: COMMAND REFERENCE INSTRUCTIONS (COMMAND OPCODES) at 471 (June 2015) (annotations added).

332. The following diagram from documentation of the Dell ‘689 Products graphic processing units shows the functionality contained on the processors that enable the retrieval of a subset of image data using access sharing during simultaneous encoding/decoding.

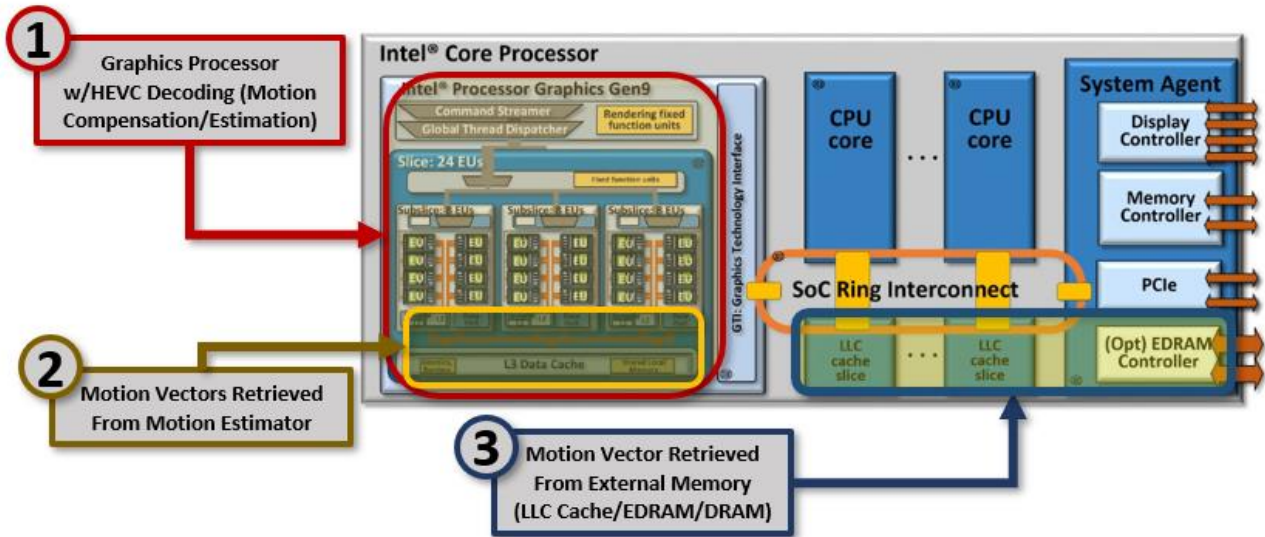

THE COMPUTE ARCHITECTURE OF INTEL PROCESSOR GRAPHICS GEN9 at 16 (August 2015) (annotations added).

333. On information and belief, one or more Dell subsidiaries and/or affiliates use the Dell ‘689 Products in regular business operations.

334. On information and belief, the Dell ‘689 Products are available to businesses and individuals throughout the United States.

335. On information and belief, the Dell ‘689 Products are provided to businesses and individuals located in the Southern District of New York.

336. By making, using, testing, offering for sale, and/or selling products and services for encoding and decoding video data, including but not limited to the Dell ‘689 Products, Dell has injured Dynamic Data and is liable to the Plaintiff for directly infringing one or more claims of the ‘689 patent, including at least claim 1 pursuant to 35 U.S.C. § 271(a).

337. On information and belief, Dell also indirectly infringes the ‘689 patent by actively inducing infringement under 35 U.S.C. § 271(b).

338. Dell has had knowledge of the '689 patent since at least service of the Original Complaint in this case or shortly thereafter, and on information and belief, Dell knew of the '689 patent and knew of its infringement, including by way of this lawsuit.

339. On information and belief, Dell intended to induce patent infringement by third-party customers and users of the Dell '689 Products and had knowledge that the inducing acts would cause infringement or was willfully blind to the possibility that its inducing acts would cause infringement. Dell specifically intended and was aware that the normal and customary use of the accused products would infringe the '689 patent. Dell performed the acts that constitute induced infringement, and would induce actual infringement, with knowledge of the '689 patent and with the knowledge that the induced acts would constitute infringement. For example, Dell provides the Dell '689 Products that have the capability of operating in a manner that infringe one or more of the claims of the '689 patent, including at least claim 1, and Dell further provides documentation and training materials that cause customers and end users of the Dell '689 Products to utilize the products in a manner that directly infringe one or more claims of the '689 patent.¹⁵³ By providing instruction and training to customers and end-users on how to use the Dell '689 Products in a manner that directly infringes one or more claims of the '689 patent, including at least claim 1, Dell specifically intended to induce infringement of the '689 patent. On information and belief, Dell engaged in such inducement to promote the sales of the Dell '689 Products, e.g., through Dell user manuals, product support, marketing materials, and training materials to actively induce the users of the accused products to infringe the '689 patent. Accordingly, Dell has induced

¹⁵³ See, e.g., *Dell G7 I5*, SETUP AND SPECIFICATIONS (2018); *Alienware Graphics Amplifier*, USER'S GUIDE (2014); *Alienware Alpha R2*, SETUP AND SPECIFICATIONS (2016); *Alienware Aurora R8*, SETUP AND SPECIFICATIONS (2018); *Inspiron 15 7000 Gaming*, SERVICE MANUAL (2017-2018); *XPS I3*, SETUP AND SPECIFICATIONS (2017); *Alienware M17x R4*, OWNER'S MANUAL (2012).

and continues to induce users of the accused products to use the accused products in their ordinary and customary way to infringe the '689 patent, knowing that such use constitutes infringement of the '689 patent.

340. The '689 patent is well-known within the industry as demonstrated by multiple citations to the '689 patent in published patents and patent applications assigned to technology companies and academic institutions. Dell is utilizing the technology claimed in the '689 patent without paying a reasonable royalty. Dell is infringing the '689 patent in a manner best described as willful, wanton, malicious, in bad faith, deliberate, consciously wrongful, flagrant, or characteristic of a pirate.

341. To the extent applicable, the requirements of 35 U.S.C. § 287(a) have been met with respect to the '689 patent.

342. As a result of Dell's infringement of the '689 patent, Dynamic Data has suffered monetary damages, and seeks recovery in an amount adequate to compensate for Dell's infringement, but in no event less than a reasonable royalty for the use made of the invention by Dell together with interest and costs as fixed by the Court.

COUNT VII
INFRINGEMENT OF U.S. PATENT NO. 6,996,177

343. Dynamic Data references and incorporates by reference the preceding paragraphs of this Complaint as if fully set forth herein.

344. Dell designs, makes, uses, sells, and/or offers for sale in the United States products and/or services for motion estimation.

345. Dell designs, makes, sells, offers to sell, imports, and/or uses Dell devices that contain H.265 video compression functionality, including but not limited to Dell desktops, laptops,

and all-in-one devices including the following exemplary models: Dell G3 3579, Dell G3 3779, Dell G5 15 5587, Dell G7 15 7588, Dell Precision 5530, Inspiron 14 Gaming 7466, Inspiron 14 Gaming 7467, Inspiron 15 Gaming 7566, Inspiron 15 Gaming 7567, Inspiron 15 Gaming 7577, Inspiron 7472, Inspiron 7572, Inspiron G3 3579, Inspiron G3 3779, Latitude 3190, Latitude 3190 2-in-1, Latitude 5420, Latitude 5424, Latitude 5491, Latitude 5591, Latitude 7424, Optiplex 3060, Optiplex 5060, Optiplex 5260 AIO, Optiplex 7060, Optiplex 7460 AIO, Optiplex 7760 AIO, Optiplex XE3, Precision 3430, Precision 3430 XL Tower, Precision 3530, Precision 3630, Precision 3630 XL Tower, Precision 3930 Rack, Precision 3930 XL RACK, Precision 5510, Precision 5520, Precision 5530, Precision 7530, Precision 7730, Precision M3800, XPS 13 9360, XPS 13 9365 2-in-1, XPS 13 9370, XPS 15 9550, XPS 15 9560, XPS 15 9570, XPS 15 9575 2-in-1, XPS Notebook 9365, XPS Notebook 9530, XPS Notebook 9550, XPS Notebook 9560, and, XPS Notebook 9570, Alienware 15, Alienware 15 R2, Alienware 15 R3, Alienware 15 R4, Alienware 17, Alienware 17 R2, Alienware 17 R3, Alienware 17 R4, Alienware 17 R5, Alienware 18, Alienware Area 51, Alienware Area-51 ALX, Alienware Area-51 R2, Alienware Area-51 R4 and R5, Alienware Area-51 Threadripper Edition R3 and R6, Alienware Area-51 Threadripper Edition R7, Alienware Aurora, Alienware Aurora ALX, Alienware Aurora R2, Alienware Aurora R3, Alienware Aurora R4, Alienware Aurora R5, Alienware Aurora R6, Alienware Aurora R7, Alienware Aurora R8, Alienware m15, Alienware M15x, Alienware M17x, Alienware M17x R2, Alienware M17x R3, Alienware M17x R4, Alienware M18x, Alienware M18x R2, Alienware X51, Alienware X51 R2, and Alienware X51 R3 (collectively, the “Dell ‘177 Product(s)”).

346. The Dell ‘177 Products perform video processing compliant with the HEVC standard. *See e.g., Dell Desktop Support, DELL SUPPORT WEBSITE, available at:*

<https://www.dell.com/support/home/us/en/19/products/desktop>; *Dell Laptop Support*, DELL SUPPORT WEBSITE, *available at*: <https://www.dell.com/support/home/us/en/19/products/laptop>

347. The below table shows Dell ‘177 Products that contain the infringing HEVC compliant video processing technology.

Exemplar Dell Models	Graphics Processing Unit (GPU)	HEVC Decode/Encode ¹⁵⁴
Dell G3 3579	NVIDIA GeForce GTX 1050 Ti ¹⁵⁵	Yes
Dell G3 3779	NVIDIA GeForce GTX 1060 w/ Max Q ¹⁵⁶	Yes
Dell G5 15 5587	NVIDIA GeForce GTX 1060 w/ Max Q ¹⁵⁷	Yes
Dell G7 15 7588	NVIDIA GeForce GTX 1060 w/ Max Q ¹⁵⁸	Yes
Inspiron 14 Gaming 7466	Intel HD Graphics 530 ¹⁵⁹	Yes
Inspiron 14 Gaming 7467	Intel HD Graphics 630 ¹⁶⁰	Yes
Inspiron 15 Gaming 7566	Intel HD Graphics 530 (Integrated) / NVIDIA GeForce GTX630M (Discrete) ¹⁶¹	Yes
Inspiron 15 Gaming 7567	NVIDIA GeForce GTX 1050Ti with 4GB GDDR5 / NVIDIA GeForce GTX 1050 with 4GB GDDR5 ¹⁶²	Yes
Inspiron 15 Gaming 7577	Intel HD Graphics 630 (Integrated) / NVIDIA GeForce GTX 1050/ GTX 1050 Ti/ GTX 1060 Max-Q (Discrete) ¹⁶³	Yes

¹⁵⁴ *NVIDIA Video Encode And Decode GPU Support Matrix*, NVIDIA DEVELOPER WEBSITE, *available at*: <https://developer.nvidia.com/video-encode-decode-gpu-support-matrix> (showing support for HEVC in NVIDIA Graphics cards); *Intel Product Matrix*, INTEL WEBSITE, *available at*: <https://www.intel.com/content/www/us/en/products> (showing HEVC Support); *Intel Graphics Product Specifications*, INTEL WEBSITE, *available at*: <https://www.intel.com/content/www/us/en/architecture-and-technology/visual-technology/graphics-overview.html>.

¹⁵⁵ *Dell Model G3 3579*, DELL WEBSITE, *available at*: <https://www.dell.com/en-us/work/shop/dell-laptops-and-notebooks/dell-g3-15-gaming-laptop/spd/g-series-15-3579-laptop>.

¹⁵⁶ *Dell Model G3 3779*, DELL WEBSITE, *available at*: <https://www.dell.com/en-us/shop/dell-laptops/dell-g3-17-gaming/spd/g-series-17-3779-laptop>.

¹⁵⁷ *Dell Model G5 15 5587*, DELL WEBSITE, *available at*: <https://www.dell.com/en-us/shop/dell-laptops/dell-g5-15-gaming/spd/g-series-15-5587-laptop>.

¹⁵⁸ *Dell Model G7 15 7588*, DELL WEBSITE, *available at*: <https://www.dell.com/en-us/shop/dell-laptops/dell-g7-15-gaming/spd/g-series-15-7588-laptop>.

¹⁵⁹ *Dell Inspiron 14 Gaming Setup and Specifications*, DELL MANUAL MODEL NO. INSPIRON 14-7466 at 18 (2016).

¹⁶⁰ *Dell Inspiron 14 7000 Gaming Series Setup and Specifications*, DELL SPECIFICATIONS MODEL NO. INSPIRON 14-7467 at 18 (2016).

¹⁶¹ *Dell Inspiron 15 Gaming Setup and Specifications*, DELL MANUAL MODEL NO. 15-7566 at 18 (2016)

¹⁶² *Dell Inspiron Model 7567*, DELL WEBSITE, *available at*: <https://www.dell.com/us/dfh/p/inspiron-15-7567-laptop/pd>.

¹⁶³ *Dell Inspiron 15 7000 Gaming Setup and Specifications*, DELL MANUAL MODEL NO. INSPIRON 15-7577 at 23 (2018).

Inspiron 5457	Intel HD Graphics 520 (integrated) / NVIDIA GeForce 930M (Discrete) ¹⁶⁴	Yes
Inspiron 5458	Intel HD Graphics 4400/4500 (integrated) / NVIDIA GeForce 920M (discrete) ¹⁶⁵	Yes
Inspiron 5557	Intel HD Graphics 520 (integrated) / NVIDIA GeForce 930M (discrete) ¹⁶⁶	Yes
Inspiron 5558	Intel HD Graphics 4400/4500 (integrated) / NVIDIA GeForce 920M (discrete) ¹⁶⁷	Yes
Inspiron 5587	NVIDIA GeForce GTX 1060 Max-Q ¹⁶⁸	Yes
Inspiron 5758	Intel HD Graphics 4400/4500 (integrated) / NVIDIA GeForce 920M (discrete) ¹⁶⁹	Yes
Inspiron 7447	Intel Iris Pro Graphic 5200 (integrated) / NVIDIA GeForce GTX 850M (discrete) ¹⁷⁰	Yes
Inspiron 7460	Intel HD Graphics 610/620/635 (integrated)/ NVIDIA GeForce 940M ¹⁷¹	Yes
Inspiron 7466	Intel HD Graphics 530 (integrated) / NVIDIA GeForce GTX 950M ¹⁷²	Yes
Alienware Area 51	NVIDIA GeForce RTX 2080 Ti OC with 11GB GDDR6 ¹⁷³	Yes
Alienware Area-51 R2	NVIDIA® GeForce GTX ¹⁷⁴	Yes
Alienware Area-51 R4/R5	NVIDIA® GeForce GTX ¹⁷⁵	Yes
Alienware Area-51 Threadripper R3/R6	NVIDIA GeForce GTX 1080 ¹⁷⁶	Yes
Alienware Area-51 Threadripper Edition R7	Dual NVIDIA® GeForce® RTX 2080 Ti OC ¹⁷⁷	Yes

¹⁶⁴ *Dell Inspiron 14 5000 Series Specification*, DELL SPECIFICATIONS MODEL NO. INSPIRON 14-5457 at 12 (2015).

¹⁶⁵ *Dell Inspiron 14 5000 Series Specification*, DELL SPECIFICATIONS MODEL NO. INSPIRON 14-5458 at 12 (2015).

¹⁶⁶ *Dell Inspiron 14 5000 Series Specification*, DELL SPECIFICATIONS MODEL NO. INSPIRON 14-5557 at 12 (2015).

¹⁶⁷ *Dell Inspiron 14 5000 Series Specification*, DELL SPECIFICATIONS MODEL NO. INSPIRON 14-5558 at 12 (2015).

¹⁶⁸ *Dell Inspiron Model 5587*, DELL WEBSITE, available at: <https://www.dell.com/en-us/shop/dell-laptops/dell-g5-15-gaming/spd/g-series-15-5587-laptop>.

¹⁶⁹ *Dell Inspiron 17 5000 Series Specification*, DELL SPECIFICATIONS MODEL NO. INSPIRON 17-5758 at 12 (2015).

¹⁷⁰ *Dell Inspiron 14 7000 Series Specification*, DELL SPECIFICATIONS MODEL NO. INSPIRON 7447 at 12 (2014).

¹⁷¹ *Dell Inspiron 14 7000 Setup and Specification*, DELL MANUAL MODEL NO. INSPIRON 14-7460 at 18 (2018)

¹⁷² *Dell Inspiron 14 Gaming Setup and Specifications*, DELL MANUAL MODEL NO. INSPIRON 14-7466 at 18 (2016).

¹⁷³ *Dell Alienware Specifications*, DELL WEBSITE, available at: <https://www.dell.com/en-us/shop/dell-desktop-computers/alienware-area-51/spd/alienware-area51-r5>.

¹⁷⁴ *Dell Alienware Specifications*, DELL WEBSITE, available at: <https://www.dell.com/en-us/shop/cty/pdp/spd/alienware-area51-r2>.

¹⁷⁵ *Dell Alienware Specifications*, DELL WEBSITE, available at: <https://www.dell.com/en-us/shop/dell-desktop-computers/alienware-area-51-gaming-desktop/spd/alienware-area51-r4>.

¹⁷⁶ *Dell Alienware Specifications*, DELL WEBSITE, available at: <https://www.dell.com/en-us/shop/dell-desktop-computers/alienware-area-51-threadripper-edition/spd/alienware-area51-r6>.

¹⁷⁷ *Dell Alienware Specifications*, DELL WEBSITE, available at: <https://www.dell.com/en-us/shop/desktops/area-51-threadripper/spd/alienware-area51-r7>.

Alienware Aurora	NVIDIA® GeForce® RTX 2080 Ti OC with 11GB GDDR6 ¹⁷⁸	Yes
------------------	--	-----

348. Dell documentation states that the Dell ‘177 Products are compliant with the HEVC standard as shown in the following excerpts.

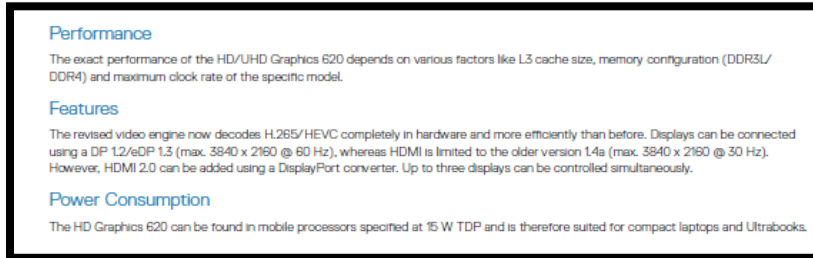

DELL LATITUDE 5420 RUGGED OWNER’S MANUAL at 44 (2015) (“The revised video engine now decodes H.265/HEVC completely in hardware and more efficiently than before.”).

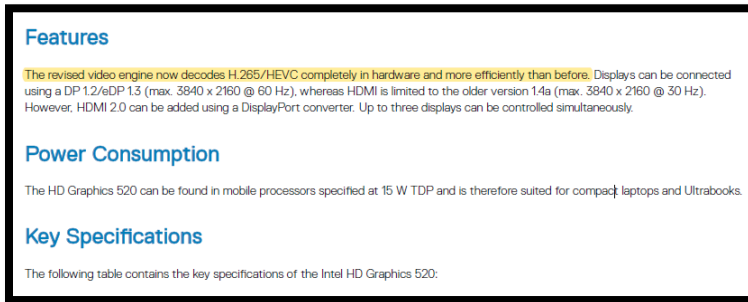

DELL VOSTRO 14-3468 OWNER’S MANUAL at 55 (2018) (annotation added) (“The revised video engine now decodes H.265/HEVC completely in hardware and more efficiently than before.”).



DELL PRODUCT QUICK REFERENCE MATRIX Q4 2018 at 17 (2018) (“New HEVC 10-bit and VP9 decode”).

¹⁷⁸ Dell Alienware Specifications, DELL WEBSITE, available at: <https://www.dell.com/en-us/shop/dell-desktop-computers/alienware-aurora/spd/alienware-aurora-r7-desktop>

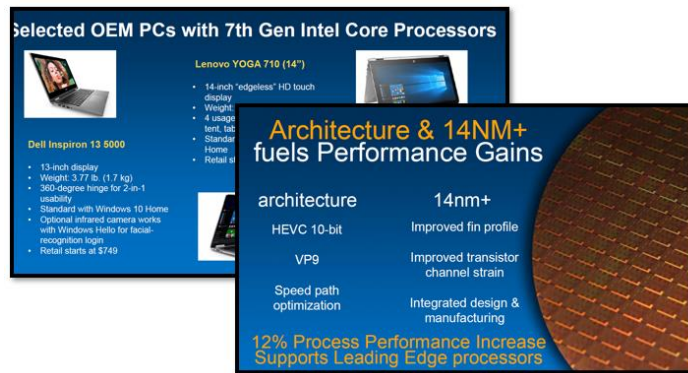

David Bradshaw, *7th Generation Intel Core Processor*, INTEL PRESENTATION at 3 & 12 (2016).

349. On information and belief, one or more Dell subsidiaries and/or affiliates use the Dell ‘177 Products in regular business operations.

350. On information and belief, one or more of the Dell ‘177 Products include technology for motion estimation and motion-compensated picture signal processing.

351. On information and belief, the Dell ‘177 Products use a block-based motion vector estimation process that compares a plurality of candidate vectors to the determine block-based motion vectors.

352. On information and belief, the Dell ‘177 Products contain a video encoder that selects an image segment of a second video image corresponding to an image segment of a first video image. The image segment has an image segment center.

353. On information and belief, documentation from Dell provides additional evidence that the Dell ‘177 products contain H.265 encoding.

354. On information and belief, the Dell ‘177 Products use a Prediction Unit matching method wherein the motion vector represents the displacement between the current Prediction Unit in the current frame and the matching Prediction Unit in the reference frame.

Motion estimation compares the current prediction unit (PU) with the spatially neighboring PUs in the reference frames, and chooses the one with the least difference

to the current PU. The displacement between the current PU and the matching PU in the reference frames is signaled using a motion vector.

Sung-Fang Tsai, *et al.*, *Encoder Hardware Architecture for HEVC*, HIGH EFFICIENCY VIDEO CODING (HEVC) at 347 (September 2014) (emphasis added).

355. On information and belief, by complying with the HEVC standard, the Dell devices – such as the Dell ‘177 Products – necessarily infringe the ‘177 patent. Mandatory sections of the HEVC standard require the elements required by certain claims of the ‘177 patent, including but not limited to claim 1. *High Efficiency Video Coding*, SERIES H: AUDIOVISUAL AND Multimedia SYSTEMS: INFRASTRUCTURE OF AUDIOVISUAL SERVICES – CODING OF MOVING VIDEO REC. ITU-T H.265 (February 2018). The following sections of the HEVC Standard are relevant to Dell’s infringement of the ‘177 patent: “7.3.4 Scaling list data syntax;” 7.3.6.1 General slice segment header syntax;” “7.3.6.3 Weighted prediction parameters syntax;” “7.3.8.14 Delta QP syntax;” “7.4.4 Profile, tier and level semantics;” and “7.4.7.3 Weighted prediction parameters semantics.”

356. On information and belief, one or more of the Dell ‘177 Products include technology for motion estimation and motion-compensated picture signal processing.

357. On information and belief, one or more of the Dell ‘177 Products include technology for estimating a current motion vector for a group of pixels of an image.

358. On information and belief, the Dell ‘177 Products carry out a block-based motion vector estimation process that involves comparing a plurality of candidate vectors to determine block-based motion vectors. The Dell ‘177 Products generate two predictor candidate motion vectors (a spatial motion vector and temporal motion vector). The first predictor candidate motion vector is drawn from a list of spatial motion vector candidates.

three spatially neighboring MVs. HEVC improves the MV prediction by applying an MV prediction competition as initially proposed in [18]. In HEVC, this competition was further adapted to large block sizes with so-called *advanced motion vector prediction* (AMVP) in [19]. In the *DIS Main profile*, AMVP has two predictor candidates competing for the prediction. Two spatial motion vector predictor (MVP) candidates are considered and, when at least one of them is not available or they are redundant, a temporal motion vector prediction (TMVP) candidate is considered. The candidates

Philipp Helle, Simon Oudin, Benjamin Bross, Detlev Marpe, M. Oguz Bici, Kemal Ugur, Joel Jung, Gordon Clare, and Thomas Wiegand, *Block Merging for Quadtree-Based Partitioning in HEVC*, IEEE TRANS. CIR. AND SYS. FOR VIDEO TECHNOLOGY, Vol. 22 No. 12 (December 2012) (“AMVP has two predictor candidates competing for the prediction. Two spatial motion vector predictor (MVP) candidates are considered and, when at least one of them is not available or they are redundant, a temporal motion vector prediction (TMVP) candidate is considered.”).

359. On information and belief, the Dell ‘177 Products utilize a motion vector selection process wherein the candidate motion vectors are constructed into an index and then the motion vectors are compared. “In AMVP, the motion vector selection process is composed by two steps in encoder implementation. The first step is the motion vector candidate set construction process and the second step is the best motion vector selection step. In the first step, the motion vector candidate set is organized by selecting the motion vectors spatially and temporally.” Gwo-Long Li, Chuen-Ching Wang, and Kuang-Hung Chiang, *An Efficient Motion Vector Prediction Method for Avoiding AMVP Data Dependency For HEVC*, 2014 IEEE INTERNATIONAL CONFERENCE ON ACOUSTIC, SPEECH AND SIGNAL PROCESSING (ICASSP) at 13 (2014).

360. On information and belief, one or more Dell subsidiaries and/or affiliates use the Dell ‘177 Products in regular business operations.

361. On information and belief, the Dell ‘177 Products are available to businesses and individuals throughout the United States.

362. On information and belief, the Dell ‘177 Products are provided to businesses and individuals located in the Southern District of New York.

363. The HEVC Standard provides details regarding what would be required for a compliant HEVC encoder—e.g., the standard uses terms such as “encoding,” “coding,” “compressing,” and other similar terms to describe the encoding process.

364. On information and belief, the Dell ‘177 Products use a block-based motion vector estimation process that compares a plurality of candidate vectors to determine block-based motion vectors. The Dell ‘177 Products contain a video encoder that selects an image segment of a second video image corresponding to an image segment of a first video image.

365. On information and belief, the Dell ‘177 Products determine at least a most frequently occurring block-based motion vector. The Dell ‘177 Products contain functionality wherein the motion vector prediction performed includes the ability to transmit in the bitstream the candidate index of motion vectors. Documentation of the encoding process states that the encoder will “pick up the MV [motion vector] to use as an estimator using the index sent by the encoder in the bitstream.”

Inter prediction

For motion vector prediction HEVC has two reference lists: L0 and L1. They can hold 16 references each, but the maximum total number of unique pictures is 8. Multiple instances of the same ref frame can be stored with different weights. HEVC motion estimation is much more complex than in AVC. It uses list indexing. There are two main prediction modes: Merge and Advanced MV. Each PU can use one of those methods and can have forward (a MV) or bi-directional prediction (2 MV). In Advanced MV mode a list of candidates MV is created (spatial and temporal candidates picked with a complex, probabilistic logic), when the list is created only the best candidate index is transmitted in the bitstream plus the MV delta (the difference between the real MV and the prediction). On the other side, the decoder will build and update continuously the same candidate list using the exact same rules used by the encoder and will pick-up the MV to use as estimator using the index sent by the encoder in the bitstream. The merge mode is similar, the main difference is that the candidates’ list is calculated from neighboring MV and is not added to a delta MV. It is the equivalent of “skip” mode in AVC.

Fabio Sonnati, *H265 – Part I: Technical Overview*, VIDEO ENCODING & STREAMING TECHNOLOGIES WEBSITE (June 20, 2014) (emphasis added).

366. On information and belief, any implementation of the HEVC standard would infringe the ‘177 patent as every possible implementation of the standard requires: compliant devices to carry out a global motion vector estimation process using the most frequently occurring

block-based motion vectors. This process of vector candidate selection allows the Dell ‘177 Products to obtain a global motion vector. Specifically, the HEVC standard generates a set of candidate motion vectors for the group of pixels, with the candidate motion vectors being extracted from a set of previously estimated motion vectors. After the candidate motion vectors are generated, if there are two spatial motion vectors that are identical, that is determined to be the most frequently occurring block-based motion vector and the frequently occurring spatial motion vector and temporal motion vector candidate are used to generate the global motion vector. “In HEVC, this competition was further adapted to large block sizes with so-called advanced motion vector prediction (AMVP). In the DIS Main profile, AMVP has two predictor candidates competing for the prediction. Two spatial motion vector predictor (MVP) candidates are considered and, when at least one of them is not available or they are redundant, a temporal motion vector prediction (TMVP) candidate is considered.” Kemal Ugur, Joel Jung, Gordon Clare, and Thomas Wiegand, *Block Merging for Quadtree-Based Partitioning in HEVC*, *IEEE TRANS. CIR. AND SYS. FOR VIDEO TECHNOLOGY*, Vol. 22 No. 12 (December 2012).

367. On information and belief, the Dell ‘177 Products apply a global motion vector as a candidate vector to the block-based motion vector estimation process. Specially, the Dell ‘177 Products calculate the global motion vector by calculating a difference between the second motion vector and the first motion vector. The further candidate motion vector is calculated at the end of the process diagram below (as shown in the below figure) and applied to the block-based motion vector estimation process.

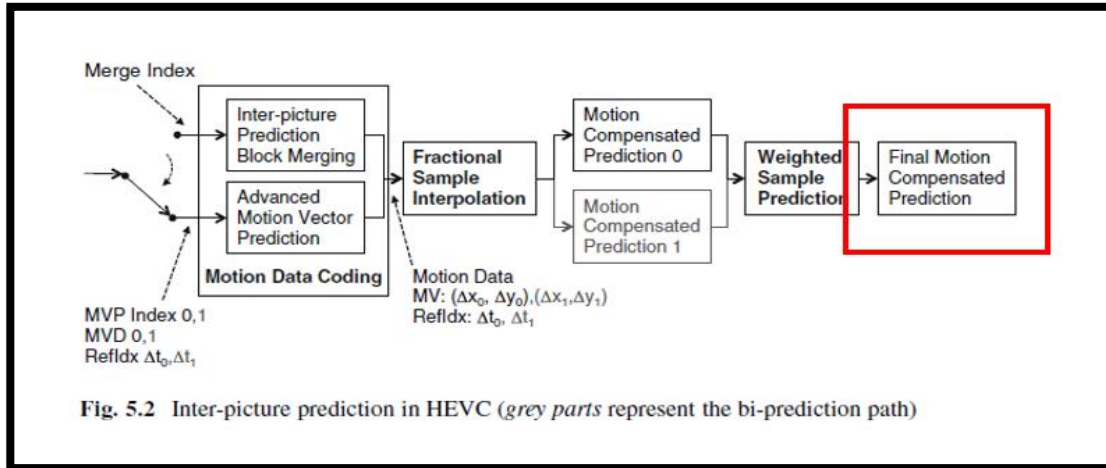

Gary J. Sullivan, *et al.*, HEVC, HIGH EFFICIENCY VIDEO CODING (HEVC) at 115 (September 2014) (emphasis added).

368. Further, the Dell ‘177 Products enable AMVP wherein several of the most probable candidate vectors based on data from adjacent prediction blocks are used to create a global estimation vector and that vector is applied to the block-based motion estimation functionality.

Motion vector signaling: Advanced motion vector prediction (AMVP) is used, including derivation of several most probable candidates based on data from adjacent PBs and the reference picture. A “merge” mode for MV coding can be also used, allowing the inheritance of MVs from neighboring PBs. Moreover, compared to H.264/MPEG-4 AVC, improved “skipped” and “direct” motion inference are also specified.

Gary J. Sullivan, *et al.*, *Overview of the High Efficiency Video Coding (HEVC) Standard*, PRE-PUBLICATION DRAFT, TO APPEAR IN IEEE TRANS. ON CIRCUITS AND SYSTEMS FOR VIDEO TECHNOLOGY at 3 (December 2012) (emphasis added).

369. On information and belief, Dell has directly infringed and continues to directly infringe the ‘177 patent by, among other things, making, using, offering for sale, and/or selling products and services for motion estimation and motion-compensated picture signal processing.

370. The Dell ‘177 Products comprise methods and devices for motion estimation and motion-compensated picture signal processing.

371. The Dell '177 Products incorporate a motion vector estimation method and device that carries out a block-based motion vector estimation process that involves comparing a plurality of candidate vectors to determine block-based motion vectors.

372. The Dell '177 Products determine at least a most frequently occurring block-based motion vector.

373. The Dell '177 Products carry out a global motion vector estimation process using at least the most frequently occurring block-based motion vector to obtain a global motion vector.

374. The Dell '177 Products applies the global motion vector as a candidate vector to the block-based motion vector estimation process.

375. By making, using, testing, offering for sale, and/or selling products and services, including but not limited to the Dell '177 Products, Dell has injured Dynamic Data and is liable for directly infringing one or more claims of the '177 patent, including at least claim 1, pursuant to 35 U.S.C. § 271(a).

376. On information and belief, Dell also indirectly infringes the '177 patent by actively inducing infringement under 35 U.S.C. § 271(b).

377. On information and belief, Dell has had knowledge of the '177 patent since at least service of the Original Complaint in this case or shortly thereafter, and on information and belief, Dell knew of the '177 patent and knew of its infringement, including by way of this lawsuit.

378. On information and belief, Dell intended to induce patent infringement by third-party customers and users of the Dell '177 Products and had knowledge that the inducing acts would cause infringement or was willfully blind to the possibility that its inducing acts would cause infringement. Dell specifically intended and was aware that the normal and customary use of the accused products would infringe the '177 patent. Dell performed the acts that constitute

induced infringement, and would induce actual infringement, with knowledge of the ‘177 patent and with the knowledge that the induced acts would constitute infringement. For example, Dell provides the Dell ‘177 Products that have the capability of operating in a manner that infringe one or more of the claims of the ‘177 patent, including at least claim 1, and Dell further provides documentation and training materials that cause customers and end users of the Dell ‘177 Products to utilize the products in a manner that directly infringe one or more claims of the ‘177 patent.¹⁷⁹ By providing instruction and training to customers and end-users on how to use the Dell ‘177 Products in a manner that directly infringes one or more claims of the ‘177 patent, including at least claim 1, Dell specifically intended to induce infringement of the ‘177 patent. On information and belief, Dell engaged in such inducement to promote the sales of the Dell ‘177 Products, e.g., through Dell user manuals, product support, marketing materials, and training materials to actively induce the users of the accused products to infringe the ‘177 patent. Accordingly, Dell has induced and continues to induce users of the accused products to use the accused products in their ordinary and customary way to infringe the ‘177 patent, knowing that such use constitutes infringement of the ‘177 patent.

379. The ‘177 patent is well-known within the industry as demonstrated by multiple citations to the ‘177 patent in published patents and patent applications assigned to technology companies and academic institutions. Dell is utilizing the technology claimed in the ‘177 patent without paying a reasonable royalty. Dell is infringing the ‘177 patent in a manner best described

¹⁷⁹ See, e.g., *Dell G7 15, SETUP AND SPECIFICATIONS* (2018); *Alienware Graphics Amplifier, USER’S GUIDE* (2014); *Alienware Aurora R8, SETUP AND SPECIFICATIONS* (2018); *Inspiron 15 7000 Gaming, SERVICE MANUAL* (2017-2018); *XPS 13, SETUP AND SPECIFICATIONS* (2017); *Dell Latitude 5420/E5420/E5420m, OWNER’S MANUAL* (2011); *Alienware M17x R4, OWNER’S MANUAL* (2012).

as willful, wanton, malicious, in bad faith, deliberate, consciously wrongful, flagrant, or characteristic of a pirate.

380. To the extent applicable, the requirements of 35 U.S.C. § 287(a) have been met with respect to the '177 patent.

381. As a result of Dell's infringement of the '177 patent, Dynamic Data has suffered monetary damages, and seeks recovery in an amount adequate to compensate for Dell's infringement, but in no event less than a reasonable royalty for the use made of the invention by Dell together with interest and costs as fixed by the Court.

COUNT VIII
INFRINGEMENT OF U.S. PATENT NO. 7,010,039

382. Dynamic Data references and incorporates by reference the preceding paragraphs of this Complaint as if fully set forth herein.

383. Dell designs, makes, uses, sells, and/or offers for sale in the United States products and/or services for detecting motion.

384. Dell designs, makes, sells, offers to sell, imports, and/or uses Dell devices that contain H.265 video compression functionality, including but not limited to Dell desktops, laptops, and all-in-one devices including the following exemplary models: Dell G3 3579, Dell G3 3779, Dell G5 15 5587, Dell G7 15 7588, Dell Precision 5530, Inspiron 14 Gaming 7466, Inspiron 14 Gaming 7467, Inspiron 15 Gaming 7566, Inspiron 15 Gaming 7567, Inspiron 15 Gaming 7577, Inspiron 7472, Inspiron 7572, Inspiron G3 3579, Inspiron G3 3779, Latitude 3190, Latitude 3190 2-in-1, Latitude 5420, Latitude 5424, Latitude 5491, Latitude 5591, Latitude 7424, Optiplex 3060, Optiplex 5060, Optiplex 5260 AIO, Optiplex 7060, Optiplex 7460 AIO, Optiplex 7760 AIO, Optiplex XE3, Precision 3430, Precision 3430 XL Tower, Precision 3530, Precision 3630,

Precision 3630 XL Tower, Precision 3930 Rack, Precision 3930 XL RACK, Precision 5510, Precision 5520, Precision 5530, Precision 7530, Precision 7730, Precision M3800, XPS 13 9360, XPS 13 9365 2-in-1, XPS 13 9370, XPS 15 9550, XPS 15 9560, XPS 15 9570, XPS 15 9575 2-in-1, XPS Notebook 9365, XPS Notebook 9530, XPS Notebook 9550, XPS Notebook 9560, and, XPS Notebook 9570, Alienware 15, Alienware 15 R2, Alienware 15 R3, Alienware 15 R4, Alienware 17, Alienware 17 R2, Alienware 17 R3, Alienware 17 R4, Alienware 17 R5, Alienware 18, Alienware Area 51, Alienware Area-51 ALX, Alienware Area-51 R2, Alienware Area-51 R4 and R5, Alienware Area-51 Threadripper Edition R3 and R6, Alienware Area-51 Threadripper Edition R7, Alienware Aurora, Alienware Aurora ALX, Alienware Aurora R2, Alienware Aurora R3, Alienware Aurora R4, Alienware Aurora R5, Alienware Aurora R6, Alienware Aurora R7, Alienware Aurora R8, Alienware m15, Alienware M15x, Alienware M17x, Alienware M17x R2, Alienware M17x R3, Alienware M17x R4, Alienware M18x, Alienware M18x R2, Alienware X51, Alienware X51 R2, and Alienware X51 R3 (collectively, the “Dell ‘039 Product(s)”).

385. The Dell ‘039 Products perform video processing compliant with the HEVC standard. *See e.g., Dell Desktop Support, DELL SUPPORT WEBSITE, available at: <https://www.dell.com/support/home/us/en/19/products/desktop>; Dell Laptop Support, DELL SUPPORT WEBSITE, available at: <https://www.dell.com/support/home/us/en/19/products/laptop>*

386. The below table shows Dell ‘039 Products that contain the infringing HEVC compliant video processing technology.

Exemplar Dell Models	Graphics Processing Unit (GPU)	HEVC Decode/Encode ¹⁸⁰
Dell G3 3579	NVIDIA GeForce GTX 1050 Ti ¹⁸¹	Yes
Dell G3 3779	NVIDIA GeForce GTX 1060 w/ Max Q ¹⁸²	Yes
Dell G5 15 5587	NVIDIA GeForce GTX 1060 w/ Max Q ¹⁸³	Yes
Dell G7 15 7588	NVIDIA GeForce GTX 1060 w/ Max Q ¹⁸⁴	Yes
Inspiron 14 Gaming 7466	Intel HD Graphics 530 ¹⁸⁵	Yes
Inspiron 14 Gaming 7467	Intel HD Graphics 630 ¹⁸⁶	Yes
Inspiron 15 Gaming 7566	Intel HD Graphics 530 (Integrated) / NVIDIA GeForce GTX630M (Discrete) ¹⁸⁷	Yes
Inspiron 15 Gaming 7567	NVIDIA GeForce GTX 1050Ti with 4GB GDDR5 / NVIDIA GeForce GTX 1050 with 4GB GDDR5 ¹⁸⁸	Yes
Inspiron 15 Gaming 7577	Intel HD Graphics 630 (Integrated) / NVIDIA GeForce GTX 1050/ GTX 1050 Ti/ GTX 1060 Max-Q (Discrete) ¹⁸⁹	Yes
Inspiron 5457	Intel HD Graphics 520 (integrated) / NVIDIA GeForce 930M (Discrete) ¹⁹⁰	Yes
Inspiron 5458	Intel HD Graphics 4400/4500 (integrated) / NVIDIA GeForce 920M (discrete) ¹⁹¹	Yes
Inspiron 5557	Intel HD Graphics 520 (integrated) / NVIDIA GeForce 930M (discrete) ¹⁹²	Yes

¹⁸⁰ *NVIDIA Video Encode And Decode GPU Support Matrix*, NVIDIA DEVELOPER WEBSITE, available at: <https://developer.nvidia.com/video-encode-decode-gpu-support-matrix> (showing support for HEVC in NVIDIA Graphics cards); *Intel Product Matrix*, INTEL WEBSITE, available at: <https://www.intel.com/content/www/us/en/products> (showing HEVC Support); *Intel Graphics Product Specifications*, INTEL WEBSITE, available at: <https://www.intel.com/content/www/us/en/architecture-and-technology/visual-technology/graphics-overview.html>.

¹⁸¹ *Dell Model G3 3579*, DELL WEBSITE, available at: <https://www.dell.com/en-us/work/shop/dell-laptops-and-notebooks/dell-g3-15-gaming-laptop/spd/g-series-15-3579-laptop>

¹⁸² *Dell Model G3 3779*, DELL WEBSITE, available at: <https://www.dell.com/en-us/shop/dell-laptops/dell-g3-17-gaming/spd/g-series-17-3779-laptop>.

¹⁸³ *Dell Model G5 15 5587*, DELL WEBSITE, available at: <https://www.dell.com/en-us/shop/dell-laptops/dell-g5-15-gaming/spd/g-series-15-5587-laptop>.

¹⁸⁴ *Dell Model G7 15 7588*, DELL WEBSITE, available at: <https://www.dell.com/en-us/shop/dell-laptops/dell-g7-15-gaming/spd/g-series-15-7588-laptop>.

¹⁸⁵ *Dell Inspiron 14 Gaming Setup and Specifications*, DELL MANUAL MODEL NO. INSPIRON 14-7466 at 18 (2016).

¹⁸⁶ *Dell Inspiron 14 7000 Gaming Series Setup and Specifications*, DELL SPECIFICATIONS MODEL NO. INSPIRON 14-7467 at 18 (2016).

¹⁸⁷ *Dell Inspiron 15 Gaming Setup and Specifications*, DELL MANUAL MODEL NO. 15-7566 at 18 (2016)

¹⁸⁸ *Dell Inspiron Model 7567*, DELL WEBSITE, available at: <https://www.dell.com/us/dfh/p/inspiron-15-7567-laptop/pd>.

¹⁸⁹ *Dell Inspiron 15 7000 Gaming Setup and Specifications*, DELL MANUAL MODEL NO. INSPIRON 15-7577 at 23 (2018).

¹⁹⁰ *Dell Inspiron 14 5000 Series Specification*, DELL SPECIFICATIONS MODEL NO. INSPIRON 14-5457 at 12 (2015).

¹⁹¹ *Dell Inspiron 14 5000 Series Specification*, DELL SPECIFICATIONS MODEL NO. INSPIRON 14-5458 at 12 (2015).

¹⁹² *Dell Inspiron 14 5000 Series Specification*, DELL SPECIFICATIONS MODEL NO. INSPIRON 14-5557 at 12 (2015).

Inspiron 5558	Intel HD Graphics 4400/4500 (integrated) / NVIDIA GeForce 920M (discrete) ¹⁹³	Yes
Inspiron 5587	NVIDIA GeForce GTX 1060 Max-Q ¹⁹⁴	Yes
Inspiron 5758	Intel HD Graphics 4400/4500 (integrated) / NVIDIA GeForce 920M (discrete) ¹⁹⁵	Yes
Inspiron 7447	Intel Iris Pro Graphic 5200 (integrated) / NVIDIA GeForce GTX 850M (discrete) ¹⁹⁶	Yes
Inspiron 7460	Intel HD Graphics 610/620/635 (integrated)/ NVIDIA GeForce 940M ¹⁹⁷	Yes
Inspiron 7466	Intel HD Graphics 530 (integrated) / NVIDIA GeForce GTX 950M ¹⁹⁸	Yes
Alienware Area 51	NVIDIA GeForce RTX 2080 Ti OC with 11GB GDDR6 ¹⁹⁹	Yes
Alienware Area-51 R2	NVIDIA® GeForce GTX ²⁰⁰	Yes
Alienware Area-51 R4/R5	NVIDIA® GeForce GTX ²⁰¹	Yes
Alienware Area-51 Threadripper R3/R6	NVIDIA GeForce GTX 1080 ²⁰²	Yes
Alienware Area-51 Threadripper Edition R7	Dual NVIDIA® GeForce® RTX 2080 Ti OC ²⁰³	Yes
Alienware Aurora	NVIDIA® GeForce® RTX 2080 Ti OC with 11GB GDDR6 ²⁰⁴	Yes

387. Dell documentation states that the Dell '039 Products are compliant with the HEVC standard as shown in the following excerpts.

¹⁹³ *Dell Inspiron 14 5000 Series Specification*, DELL SPECIFICATIONS MODEL NO. INSPIRON 14-5558 at 12 (2015).

¹⁹⁴ *Dell Inspiron Model 5587*, DELL WEBSITE, available at: <https://www.dell.com/en-us/shop/dell-laptops/dell-g5-15-gaming/spd/g-series-15-5587-laptop>

¹⁹⁵ *Dell Inspiron 17 5000 Series Specification*, DELL SPECIFICATIONS MODEL NO. INSPIRON 17-5758 at 12 (2015).

¹⁹⁶ *Dell Inspiron 14 7000 Series Specification*, DELL SPECIFICATIONS MODEL NO. INSPIRON 7447 at 12 (2014).

¹⁹⁷ *Dell Inspiron 14 7000 Setup and Specification*, DELL MANUAL MODEL NO. INSPIRON 14-7460 at 18 (2018).

¹⁹⁸ *Dell Inspiron 14 Gaming Setup and Specifications*, DELL MANUAL MODEL NO. INSPIRON 14-7466 at 18 (2016).

¹⁹⁹ *Dell Alienware Specifications*, DELL WEBSITE, available at: <https://www.dell.com/en-us/shop/dell-desktop-computers/alienware-area-51/spd/alienware-area51-r5>.

²⁰⁰ *Dell Alienware Specifications*, DELL WEBSITE, available at: <https://www.dell.com/en-us/shop/cty/pdp/spd/alienware-area51-r2>.

²⁰¹ *Dell Alienware Specifications*, DELL WEBSITE, available at: <https://www.dell.com/en-us/shop/dell-desktop-computers/alienware-area-51-gaming-desktop/spd/alienware-area51-r4>.

²⁰² *Dell Alienware Specifications*, DELL WEBSITE, available at: <https://www.dell.com/en-us/shop/dell-desktop-computers/alienware-area-51-threadripper-edition/spd/alienware-area51-r6>.

²⁰³ *Dell Alienware Specifications*, DELL WEBSITE, available at: <https://www.dell.com/en-us/shop/desktops/area-51-threadripper/spd/alienware-area51-r7>.

²⁰⁴ *Dell Alienware Specifications*, DELL WEBSITE, available at: <https://www.dell.com/en-us/shop/dell-desktop-computers/alienware-aurora/spd/alienware-aurora-r7-desktop>.

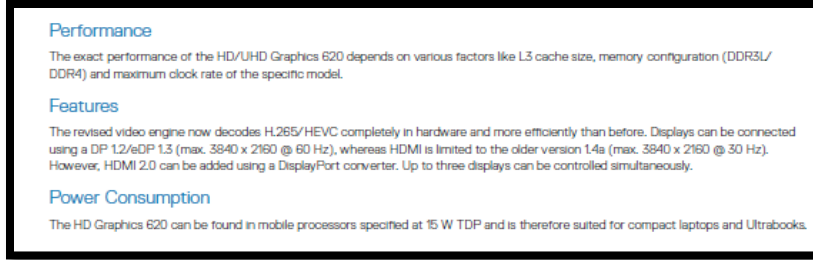

DELL LATITUDE 5420 RUGGED OWNER’S MANUAL at 44 (2015) (“The revised video engine now decodes H.265/HEVC completely in hardware and more efficiently than before.”).

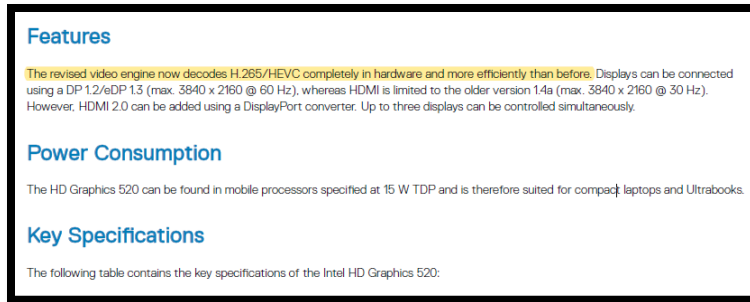

DELL VOSTRO 14-3468 OWNER’S MANUAL at 55 (2018) (annotation added) (“The revised video engine now decodes H.265/HEVC completely in hardware and more efficiently than before.”).



DELL PRODUCT QUICK REFERENCE MATRIX Q4 2018 at 17 (2018) (“New HEVC 10-bit and VP9 decode”).

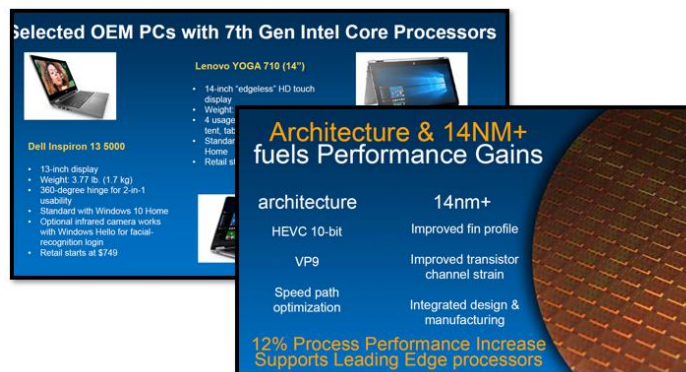

David Bradshaw, 7th Generation Intel Core Processor, INTEL PRESENTATION at 3 & 12 (2016).

388. On information and belief, the Dell '039 Products contain functionality wherein a criterion function for candidate vectors is optimized. The criterion function depends on data obtained from the previous and next images in the video data stream. The optimizing is carried out at a temporal intermediate position in non-covered and covered areas. The following excerpts explain how HEVC is a form of encoding video information using a temporal intermediate position between previous and next images.

One way of achieving high video compression is to predict pixel values for a frame based on prior and succeeding pictures in the video. Like its predecessors, H.265 features the ability to predict pixel values between pictures, and in particular, to specify in which order pictures are coded and which pictures are predicted from which. The coding order is specified for Groups Of Pictures (GOP), where a number of pictures are grouped together and predicted from each other in a specified order. The pictures available to predict from, called reference pictures, are specified for every individual picture.

Johan Bartelmess. *Compression Efficiency of Different Picture Coding Structures in High Efficiency Video Coding (HEVC)*, UPTEC STS 16006 at 4 (March 2016)

HEVC features both low- and high-level methods for dependency removal which can be used to leverage multi-core processors [13]. Only the three high-level mechanisms slices, tiles and WPP are of interest for this work. It is important to note that all of them subdivide individual video frames based on CTUs which are HEVC's basic processing unit. CTUs have a maximum size of 64×64 luma pixels and are recursively split into square-shaped Coding Units (CUs), which contain Prediction Units (PUs) and Transform Units (TUs) [14].

Stefan Radicke, *et al.*, *Many-Core HEVC Encoding Based on Wavefront Parallel Processing and GPU-accelerated Motion Estimation*, E-BUSINESS AND TELECOMMUNICATIONS: 11TH INTERNATIONAL JOINT CONFERENCE at 296 (2015) (“HEVC feature both low- and high-level methods for dependency removal which can be used to leverage multi-core processors. . . It is important to note that all of them subdivide individual video frames based on CTUs which are HEVC' basic processing unit.”).

389. On information and belief, the Dell '039 Products receive encoded video data that is encoded using inter-frame coding. The encoded video stream received by the Dell Products are coded using its predecessor frame and subsequent frame. Inter-prediction used in the encoded video data received by the Dell Products allows a transform block to span across multiple

prediction blocks for inter-picture predicted coding units to maximize the potential coding efficiency benefits of the quadtree-structured transform block partitioning.

The basic source-coding algorithm is a hybrid of interpicture prediction to exploit *temporal statistical dependences*, intrapicture prediction to exploit spatial statistical dependences, and transform coding of the prediction residual signals to further exploit spatial statistical dependences.

G. J. Sullivan, J.-R. Ohm, W.-J. Han, and T. Wiegand, *Overview of the High Efficiency Video Coding (HEVC) standard*, IEEE TRANS. CIRCUITS SYST. VIDEO TECHNOL., vol. 22, no. 12, p. 1654 (December 2012) (emphasis added).

390. The encoded video stream received by the Dell Products are encoded using inter-picture prediction that makes use of the temporal correlation between pictures to derive a motion-compensated prediction (MCP) for a block of image samples. For this block-based motion compensated prediction, a video picture is divided into rectangular blocks. Assuming homogeneous motion inside one block, and that moving objects are larger than one block, for each block, a corresponding block in a previously decoded picture can be found that serves as a predictor. The general concept of inter-frame-based encoding using motion-compensated prediction based on a translational motion model is illustrated below.

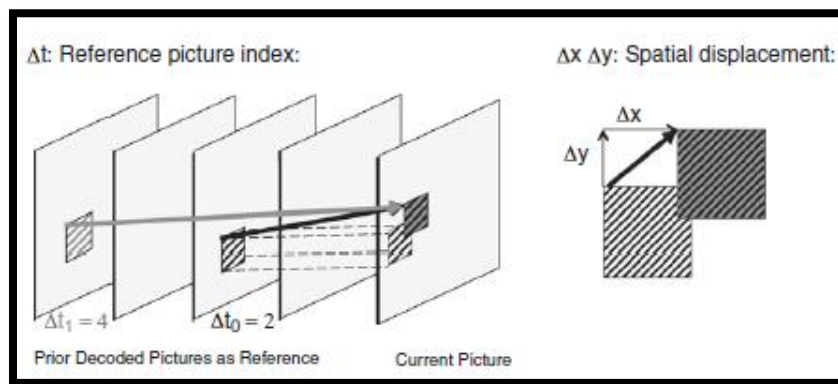

Benjamin Bross, *Inter-Picture Prediction In HEVC*, HIGH EFFICIENCY VIDEO CODING (HEVC) at 114 (September 2014).

391. On information and belief, the following excerpt from an article describing the architecture of the encoded video stream received by the Dell '039 Products describes the

functionality wherein the second encoded frame of the video data is dependent on the encoding of a first frame. “HEVC inter prediction uses motion vectors pointing to one reference frame . . . or two reference frames (bi-prediction) to predict a block of pixels.”

HEVC inter prediction uses motion vectors pointing to one reference frame (uni-prediction) or two reference frames (bi-prediction) to predict a block of pixels. The size of the predicted block, called Prediction Unit (PU), is determined by the Coding Unit (CU) size and its partitioning mode. For example, a 32×32 CU with $2N \times N$ partitioning is split into two PUs of size 32×16 , or a 16×16 CU with $nL \times 2N$ partitioning is split into 4×16 and 12×16 PUs.

Mehul Tikekar, *et al.*, *Decoder Hardware Architecture for HEVC*, HIGH EFFICIENCY VIDEO CODING (HEVC) (September 2014).

392. On information and belief, the following diagram shows how the Dell ‘039 Products receive video data encoded using inter-frame prediction. Specifically, interframe prediction generates a motion vector based on the motion estimation across frames.

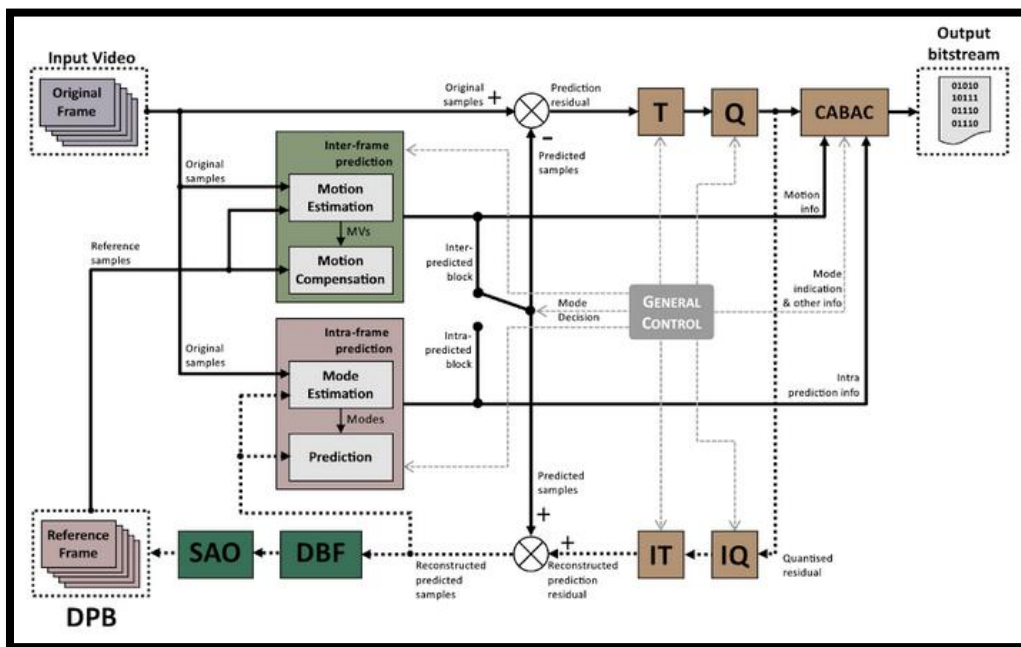

Guilherme Corrêa, *et al.*, *COMPLEXITY-AWARE HIGH EFFICIENCY VIDEO CODING at 16* (2015).

393. On information and belief, the Dell ‘039 Products receive encoded video data wherein the second frame includes a region encoding a motion vector difference in position

between the region corresponding to the second frame indicating the first frame, the motion vector defines a region between the frame and the second frame corresponding to the first region the correspondence relationship. Specifically, the encoded video data received by the Dell Products use a translational motion model wherein the position of the block in a previously decoded picture is indicated by a motion vector: Δx ; Δy where Δx specifies the horizontal and Δy the vertical displacement relative to the position of the current block. The motion vectors: Δx ; Δy are of fractional sample accuracy to more accurately capture the movement of the underlying object. Interpolation is applied on the reference pictures to derive the prediction signal when the corresponding motion vector has fractional sample accuracy. The previously decoded picture is referred to as the reference picture and indicated by a reference index Δt to a reference picture list. These translational motion model parameters, *i.e.*, motion vectors and reference indices, are further referred to as motion data.

394. The Dell '039 Products optimize the selection of candidate vectors by calculation a temporal position of the next image in covering areas and at the temporal position of the previous image in uncovering areas. Specifically, the encoding process for video data received by the Dell Products use inter-picture prediction wherein motion data comprises the selection of a reference frame and motion vectors to be applied in predicting the samples of each block.

395. On information and belief, the “Overview of Design Characteristics” in the HEVC specification describes the use of “motion vectors for block-based inter prediction to exploit temporal statistical dependencies between frames.”

compression. Encoding algorithms (not specified in this Recommendation | International Standard) may select between inter and intra coding for block-shaped regions of each picture. **Inter coding uses motion vectors for block-based inter prediction to exploit temporal statistical dependencies between different pictures.** Intra coding uses various spatial prediction modes to exploit spatial statistical dependencies in the source signal for a single picture. Motion vectors and intra prediction modes may be specified for a variety of block sizes in the picture. The prediction residual may then be further compressed using a transform to remove spatial correlation inside the transform block before it is quantized, producing a possibly irreversible process that typically discards less important visual information while forming a close approximation to the source samples. Finally, the motion vectors or intra prediction modes may also be further compressed using a variety of prediction mechanisms, and, after prediction, are combined with the quantized transform coefficient information and encoded using arithmetic coding.

High Efficiency Video Coding, Series H: Audiovisual And Multimedia Systems: Infrastructure Of Audiovisual Services – Coding Of Moving Video Rec. ITU-T H.265 at § 0.7 (April 2015) (annotation added).

396. On information and belief, by complying with the HEVC standard, the Dell devices – such as the Dell ‘039 Products – necessarily infringe the ‘039 patent. Mandatory sections of the HEVC standard require the elements required by certain claims of the ‘039 patent, including but not limited to claim 13. *High Efficiency Video Coding, SERIES H: AUDIOVISUAL AND Multimedia SYSTEMS: INFRASTRUCTURE OF AUDIOVISUAL SERVICES – CODING OF MOVING VIDEO REC. ITU-T H.265 (February 2018).* The following sections of the HEVC Standard are relevant to Dell’s infringement of the ‘039 patent: “5.3 Logical operators;” “5.10 Variables, syntax elements and tables;” “5.11 Text description of logical operations;” “7.2 Specification of syntax functions and descriptors;” “7.3.1 NAL unit syntax;” “7.3.2 Raw byte sequence payloads, trailing bits and byte alignment syntax;” “7.3.5 Supplemental enhancement information message syntax;” “7.4.2 NAL unit semantics;” and “7.4.6 Supplemental enhancement information message semantics.”

397. On information and belief, one or more Dell subsidiaries and/or affiliates use the Dell ‘039 Products in regular business operations.

398. On information and belief, one or more of the Dell ‘039 Products include technology for detecting motion.

399. On information and belief, the Dell ‘039 Products are available to businesses and individuals throughout the United States.

400. On information and belief, the Dell '039 Products are provided to businesses and individuals located in the Southern District of New York.

401. On information and belief, Dell has directly infringed and continues to directly infringe the '039 patent by, among other things, making, using, offering for sale, and/or selling technology for detecting motion, including but not limited to the Dell '039 Products.

402. On information and belief, the Dell '039 Products detect motion at a temporal intermediate position between previous and next images.

403. On information and belief, the Dell '039 Products carry out the optimization at the temporal position of the next image in covering areas and at the temporal position of the previous image in uncovering areas.

404. On information and belief, the Dell '039 Products detect motion at a temporal intermediate position between previous and next images.

405. On information and belief, the Dell '039 Products utilize a criterion function for candidate vectors that is optimized.

406. On information and belief, the Dell '039 Products utilize a criterion function that depends on data from both previous and next images and in which the optimizing is carried out at the temporal intermediate position in non-covering and non-uncovering areas, characterized in that the optimizing is carried out at the temporal position of the next image in covering areas and at the temporal position of the previous image in uncovering areas.

407. By making, using, testing, offering for sale, and/or selling products and services, including but not limited to the Dell '039 Products, Dell has injured Dynamic Data and is liable for directly infringing one or more claims of the '039 patent, including at least claim 13, pursuant to 35 U.S.C. § 271(a).

408. On information and belief, Dell also indirectly infringes the '039 patent by actively inducing infringement under 35 U.S.C. § 271(b).

409. On information and belief, Dell has had knowledge of the '039 patent since at least service of the Original Complaint in this matter or shortly thereafter, and on information and belief, Dell knew of the '039 patent and knew of its infringement, including by way of this lawsuit.

410. On information and belief, Dell intended to induce patent infringement by third-party customers and users of the Dell '039 Products and had knowledge that the inducing acts would cause infringement or was willfully blind to the possibility that its inducing acts would cause infringement. Dell specifically intended and was aware that the normal and customary use of the accused products would infringe the '039 patent. Dell performed the acts that constitute induced infringement, and would induce actual infringement, with knowledge of the '039 patent and with the knowledge that the induced acts would constitute infringement. For example, Dell provides the Dell '039 Products that have the capability of operating in a manner that infringe one or more of the claims of the '039 patent, including at least claim 13, and Dell further provides documentation and training materials that cause customers and end users of the Dell '039 Products to utilize the products in a manner that directly infringe one or more claims of the '039 patent.²⁰⁵ By providing instruction and training to customers and end-users on how to use the Dell '039 Products in a manner that directly infringes one or more claims of the '039 patent, including at least claim 13, Dell specifically intended to induce infringement of the '039 patent. On information and belief, Dell engaged in such inducement to promote the sales of the Dell '039

²⁰⁵ See, e.g., *Dell G7 15*, SETUP AND SPECIFICATIONS (2018); *Alienware Graphics Amplifier*, USER'S GUIDE (2014); *Alienware Aurora R8*, SETUP AND SPECIFICATIONS (2018); *Inspiron 15 7000 Gaming*, SERVICE MANUAL (2017-2018); *XPS 13*, SETUP AND SPECIFICATIONS (2017); *Dell Latitude 5420/E5420/E5420m*, OWNER'S MANUAL (2011); *Alienware M17x R4*, OWNER'S MANUAL (2012); *Dell Vostro 15-3558*, OWNER'S MANUAL (2015).

Products, e.g., through Dell user manuals, product support, marketing materials, and training materials to actively induce the users of the accused products to infringe the '039 patent. Accordingly, Dell has induced and continues to induce users of the accused products to use the accused products in their ordinary and customary way to infringe the '039 patent, knowing that such use constitutes infringement of the '039 patent.

411. To the extent applicable, the requirements of 35 U.S.C. § 287(a) have been met with respect to the '039 patent.

412. As a result of Dell's infringement of the '039 patent, Dynamic Data has suffered monetary damages, and seeks recovery in an amount adequate to compensate for Dell's infringement, but in no event less than a reasonable royalty for the use made of the invention by Dell together with interest and costs as fixed by the Court.

COUNT IX
INFRINGEMENT OF U.S. PATENT NO. 8,311,112

413. Dynamic Data references and incorporates by reference the preceding paragraphs of this Complaint as if fully set forth herein.

414. Dell designs, makes, uses, sells, and/or offers for sale in the United States products and/or services for video compression.

415. Dell designs, makes, sells, offers to sell, imports, and/or uses Dell devices that contain H.265 video compression functionality, including but not limited to Dell desktops, laptops, and all-in-one devices including the following exemplary models: Dell G3 3579, Dell G3 3779, Dell G5 15 5587, Dell G7 15 7588, Dell Precision 5530, Inspiron 14 Gaming 7466, Inspiron 14 Gaming 7467, Inspiron 15 Gaming 7566, Inspiron 15 Gaming 7567, Inspiron 15 Gaming 7577, Inspiron 7472, Inspiron 7572, Inspiron G3 3579, Inspiron G3 3779, Latitude 3190, Latitude 3190

2-in-1, Latitude 5420, Latitude 5424, Latitude 5491, Latitude 5591, Latitude 7424, Optiplex 3060, Optiplex 5060, Optiplex 5260 AIO, Optiplex 7060, Optiplex 7460 AIO, Optiplex 7760 AIO, Optiplex XE3, Precision 3430, Precision 3430 XL Tower, Precision 3530, Precision 3630, Precision 3630 XL Tower, Precision 3930 Rack, Precision 3930 XL RACK, Precision 5510, Precision 5520, Precision 5530, Precision 7530, Precision 7730, Precision M3800, XPS 13 9360, XPS 13 9365 2-in-1, XPS 13 9370, XPS 15 9550, XPS 15 9560, XPS 15 9570, XPS 15 9575 2-in-1, XPS Notebook 9365, XPS Notebook 9530, XPS Notebook 9550, XPS Notebook 9560, and, XPS Notebook 9570, Alienware 15, Alienware 15 R2, Alienware 15 R3, Alienware 15 R4, Alienware 17, Alienware 17 R2, Alienware 17 R3, Alienware 17 R4, Alienware 17 R5, Alienware 18, Alienware Area 51, Alienware Area-51 ALX, Alienware Area-51 R2, Alienware Area-51 R4 and R5, Alienware Area-51 Threadripper Edition R3 and R6, Alienware Area-51 Threadripper Edition R7, Alienware Aurora, Alienware Aurora ALX, Alienware Aurora R2, Alienware Aurora R3, Alienware Aurora R4, Alienware Aurora R5, Alienware Aurora R6, Alienware Aurora R7, Alienware Aurora R8, Alienware m15, Alienware M15x, Alienware M17x, Alienware M17x R2, Alienware M17x R3, Alienware M17x R4, Alienware M18x, Alienware M18x R2, Alienware X51, Alienware X51 R2, and Alienware X51 R3 (collectively, the “Dell ‘112 Product(s)”).

416. The Dell ‘112 Products perform video processing compliant with the HEVC standard. *See e.g., Dell Desktop Support, DELL SUPPORT WEBSITE, available at: <https://www.dell.com/support/home/us/en/19/products/desktop>; Dell Laptop Support, DELL SUPPORT WEBSITE, available at: <https://www.dell.com/support/home/us/en/19/products/laptop>*

417. The below table shows Dell ‘112 Products that contain the infringing HEVC compliant video processing technology.

Exemplar Dell Models	Graphics Processing Unit (GPU)	HEVC Decode/Encode ²⁰⁶
Dell G3 3579	NVIDIA GeForce GTX 1050 Ti ²⁰⁷	Yes
Dell G3 3779	NVIDIA GeForce GTX 1060 w/ Max Q ²⁰⁸	Yes
Dell G5 15 5587	NVIDIA GeForce GTX 1060 w/ Max Q ²⁰⁹	Yes
Dell G7 15 7588	NVIDIA GeForce GTX 1060 w/ Max Q ²¹⁰	Yes
Inspiron 14 Gaming 7466	Intel HD Graphics 530 ²¹¹	Yes
Inspiron 14 Gaming 7467	Intel HD Graphics 630 ²¹²	Yes
Inspiron 15 Gaming 7566	Intel HD Graphics 530 (Integrated) / NVIDIA GeForce GTX630M (Discrete) ²¹³	Yes
Inspiron 15 Gaming 7567	NVIDIA GeForce GTX 1050Ti with 4GB GDDR5 / NVIDIA GeForce GTX 1050 with 4GB GDDR5 ²¹⁴	Yes
Inspiron 15 Gaming 7577	Intel HD Graphics 630 (Integrated) / NVIDIA GeForce GTX 1050/ GTX 1050 Ti/ GTX 1060 Max-Q (Discrete) ²¹⁵	Yes
Inspiron 5457	Intel HD Graphics 520 (integrated) / NVIDIA GeForce 930M (Discrete) ²¹⁶	Yes
Inspiron 5458	Intel HD Graphics 4400/4500 (integrated) / NVIDIA GeForce 920M (discrete) ²¹⁷	Yes
Inspiron 5557	Intel HD Graphics 520 (integrated) / NVIDIA GeForce 930M (discrete) ²¹⁸	Yes

²⁰⁶ *NVIDIA Video Encode And Decode GPU Support Matrix*, NVIDIA DEVELOPER WEBSITE, available at: <https://developer.nvidia.com/video-encode-decode-gpu-support-matrix> (showing support for HEVC in NVIDIA Graphics cards); *Intel Product Matrix*, INTEL WEBSITE, available at: <https://www.intel.com/content/www/us/en/products> (showing HEVC Support); *Intel Graphics Product Specifications*, INTEL WEBSITE, available at: <https://www.intel.com/content/www/us/en/architecture-and-technology/visual-technology/graphics-overview.html>.

²⁰⁷ *Dell Model G3 3579*, DELL WEBSITE, available at: <https://www.dell.com/en-us/work/shop/dell-laptops-and-notebooks/dell-g3-15-gaming-laptop/spd/g-series-15-3579-laptop>

²⁰⁸ *Dell Model G3 3779*, DELL WEBSITE, available at: <https://www.dell.com/en-us/shop/dell-laptops/dell-g3-17-gaming/spd/g-series-17-3779-laptop>

²⁰⁹ *Dell Model G5 15 5587*, DELL WEBSITE, available at: <https://www.dell.com/en-us/shop/dell-laptops/dell-g5-15-gaming/spd/g-series-15-5587-laptop>

²¹⁰ *Dell Model G7 15 7588*, DELL WEBSITE, available at: <https://www.dell.com/en-us/shop/dell-laptops/dell-g7-15-gaming/spd/g-series-15-7588-laptop>

²¹¹ *Dell Inspiron 14 Gaming Setup and Specifications*, DELL MANUAL MODEL NO. INSPIRON 14-7466 at 18 (2016).

²¹² *Dell Inspiron 14 7000 Gaming Series Setup and Specifications*, DELL SPECIFICATIONS MODEL NO. INSPIRON 14-7467 at 18 (2016)

²¹³ *Dell Inspiron 15 Gaming Setup and Specifications*, DELL MANUAL MODEL NO. 15-7566 at 18 (2016)

²¹⁴ *Dell Inspiron Model 7567*, DELL WEBSITE, available at: <https://www.dell.com/us/dfh/p/inspiron-15-7567-laptop/pd>

²¹⁵ *Dell Inspiron 15 7000 Gaming Setup and Specifications*, DELL MANUAL MODEL NO. INSPIRON 15-7577 at 23 (2018).

²¹⁶ *Dell Inspiron 14 5000 Series Specification*, DELL SPECIFICATIONS MODEL NO. INSPIRON 14-5457 at 12 (2015).

²¹⁷ *Dell Inspiron 14 5000 Series Specification*, DELL SPECIFICATIONS MODEL NO. INSPIRON 14-5458 at 12 (2015).

²¹⁸ *Dell Inspiron 14 5000 Series Specification*, DELL SPECIFICATIONS MODEL NO. INSPIRON 14-5557 at 12 (2015).

Inspiron 5558	Intel HD Graphics 4400/4500 (integrated) / NVIDIA GeForce 920M (discrete) ²¹⁹	Yes
Inspiron 5587	NVIDIA GeForce GTX 1060 Max-Q ²²⁰	Yes
Inspiron 5758	Intel HD Graphics 4400/4500 (integrated) / NVIDIA GeForce 920M (discrete) ²²¹	Yes
Inspiron 7447	Intel Iris Pro Graphic 5200 (integrated) / NVIDIA GeForce GTX 850M (discrete) ²²²	Yes
Inspiron 7460	Intel HD Graphics 610/620/635 (integrated)/ NVIDIA GeForce 940M ²²³	Yes
Inspiron 7466	Intel HD Graphics 530 (integrated) / NVIDIA GeForce GTX 950M ²²⁴	Yes
Alienware Area 51	NVIDIA GeForce RTX 2080 Ti OC with 11GB GDDR6 ²²⁵	Yes
Alienware Area-51 R2	NVIDIA® GeForce GTX ²²⁶	Yes
Alienware Area-51 R4/R5	NVIDIA® GeForce GTX ²²⁷	Yes
Alienware Area-51 Threadripper R3/R6	NVIDIA GeForce GTX 1080 ²²⁸	Yes
Alienware Area-51 Threadripper Edition R7	Dual NVIDIA® GeForce® RTX 2080 Ti OC ²²⁹	Yes
Alienware Aurora	NVIDIA® GeForce® RTX 2080 Ti OC with 11GB GDDR6 ²³⁰	Yes

418. Dell documentation states that the Dell ‘112 Products are compliant with the HEVC standard as shown in the following excerpts.

²¹⁹ *Dell Inspiron 14 5000 Series Specification*, DELL SPECIFICATIONS MODEL NO. INSPIRON 14-5558 at 12 (2015).

²²⁰ *Dell Inspiron Model 5587*, DELL WEBSITE, available at: <https://www.dell.com/en-us/shop/dell-laptops/dell-g5-15-gaming/spd/g-series-15-5587-laptop>

²²¹ *Dell Inspiron 17 5000 Series Specification*, DELL SPECIFICATIONS MODEL NO. INSPIRON 17-5758 at 12 (2015).

²²² *Dell Inspiron 14 7000 Series Specification*, DELL SPECIFICATIONS MODEL NO. INSPIRON 7447 at 12 (2014).

²²³ *Dell Inspiron 14 7000 Setup and Specification*, DELL MANUAL MODEL NO. INSPIRON 14-7460 at 18 (2018)

²²⁴ *Dell Inspiron 14 Gaming Setup and Specifications*, DELL MANUAL MODEL NO. INSPIRON 14-7466 at 18 (2016).

²²⁵ *Dell Alienware Specifications*, DELL WEBSITE, available at: <https://www.dell.com/en-us/shop/dell-desktop-computers/alienware-area-51/spd/alienware-area51-r5>

²²⁶ *Dell Alienware Specifications*, DELL WEBSITE, available at: <https://www.dell.com/en-us/shop/cty/pdp/spd/alienware-area51-r2>

²²⁷ *Dell Alienware Specifications*, DELL WEBSITE, available at: <https://www.dell.com/en-us/shop/dell-desktop-computers/alienware-area-51-gaming-desktop/spd/alienware-area51-r4>

²²⁸ *Dell Alienware Specifications*, DELL WEBSITE, available at: <https://www.dell.com/en-us/shop/dell-desktop-computers/alienware-area-51-threadripper-edition/spd/alienware-area51-r6>

²²⁹ *Dell Alienware Specifications*, DELL WEBSITE, available at: <https://www.dell.com/en-us/shop/desktops/area-51-threadripper/spd/alienware-area51-r7>

²³⁰ *Dell Alienware Specifications*, DELL WEBSITE, available at: <https://www.dell.com/en-us/shop/dell-desktop-computers/alienware-aurora/spd/alienware-aurora-r7-desktop>

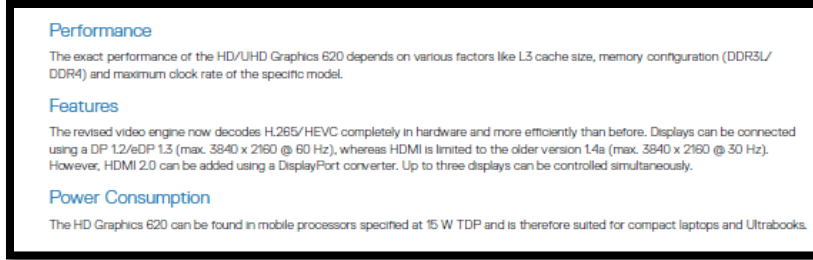

DELL LATITUDE 5420 RUGGED OWNER’S MANUAL at 44 (2015) (“The revised video engine now decodes H.265/HEVC completely in hardware and more efficiently than before.”).

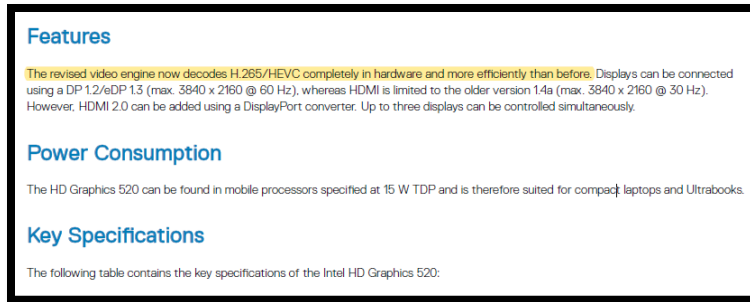

DELL VOSTRO 14-3468 OWNER’S MANUAL at 55 (2018) (annotation added) (“The revised video engine now decodes H.265/HEVC completely in hardware and more efficiently than before.”).



DELL PRODUCT QUICK REFERENCE MATRIX Q4 2018 at 17 (2018) (“New HEVC 10-bit and VP9 decode”).

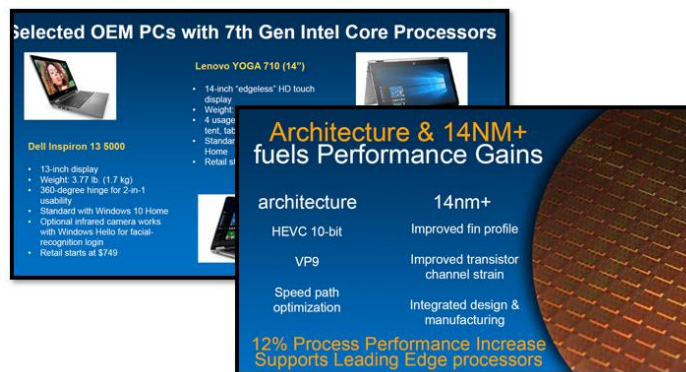

David Bradshaw, 7th Generation Intel Core Processor, INTEL PRESENTATION at 3 & 12 (2016).

419. On information and belief, the Dell ‘112 Products select the selected image selection area based on a range of possible motion vectors in the selected image search area. Further, the search area of the selected image segment has a center. Specifically, the Dell ‘112 Products contain functionality for selecting a coding unit. The coding unit comprises a selected image segment.

420. On information and belief, the H.265/HEVC encoding performed by the Dell ‘112 Products enables the selection of an image segment of a given image corresponding to an image segment of a first video image. The selected image segment has a center and a search area is defined around the image segment.

421. The Dell ‘112 Products contain an image processing unit that receives, at a minimum, two frames of a video from memory. These frames are then processed by the video compensation unit of the Dell Products. Further, the Dell Products contain an encoder for motion estimation. “[T]he encoder needs to perform motion estimation, which is one of the most computationally expensive operations in the encoder, and complexity is reduced by allowing less candidates.”²³¹

422. The Dell ‘112 Products perform encoding using motion compensation, specifically, inter-picture prediction wherein the Dell Product makes use of the temporal correlation between pictures in order to derive a motion-compensated prediction for a block of image samples. Each image is divided into blocks (prediction units) and the Dell ‘112 Product compares the prediction unit in a first image with the spatially neighboring prediction units in a second image (reference

²³¹ Gary J. Sullivan, *et al.*, *Overview of the High Efficiency Video Coding (HEVC) Standard*, PRE-PUBLICATION DRAFT, TO APPEAR IN IEEE TRANS. ON CIRCUITS AND SYSTEMS FOR VIDEO TECHNOLOGY at 13 (December 2012) (emphasis added).

image). The displacement between the current prediction unit and the matching prediction unit in the second image (reference image) is signaled using a motion vector.

423. The Dell ‘112 Products contain functionality wherein during the motion estimation process the block size used for prediction units can range from $4 \times 8/8 \times 4$ to 64×64 .

A block-wise prediction residual is computed from corresponding regions of previously decoded pictures (inter-picture motion compensated prediction) or neighboring previously decoded samples from the same picture (intra-picture spatial prediction). The residual is then processed by a block transform, and the transform coefficients are quantized and entropy coded. Side information data such as motion vectors and mode switching parameters are also encoded and transmitted.

Standardized Extensions of High Efficiency Video Coding (HEVC), IEEE JOURNAL OF SELECTED TOPICS IN SIGNAL PROCESSING, Vol. 7, No. 6 at 1002 (December 2013) (emphasis added).

424. The Dell ‘112 Products use intra-picture estimation between blocks (prediction units) within an image retrieved from memory. The frames are then processed using both motion compensation and motion estimation. The motion compensation functionality used by the Dell Products include quarter-sample precision for the motion vectors and 7-tap or 8-tap filters that are used for interpolation of fractional-sample positions.

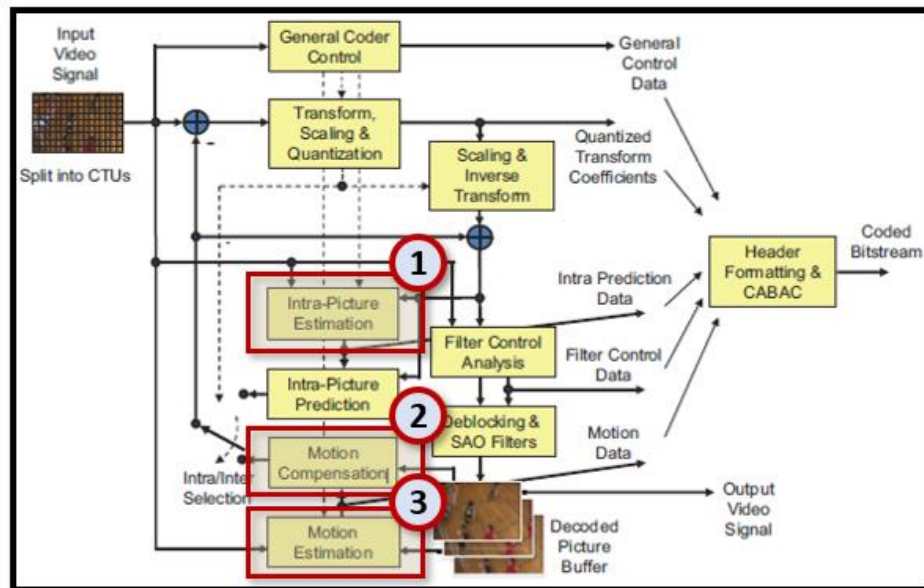

Standardized Extensions of High Efficiency Video Coding (HEVC), IEEE JOURNAL OF SELECTED TOPICS IN SIGNAL PROCESSING, VOL. 7, NO. 6 at 1002 (December 2013) (emphasis added) (the

annotations showing (1) intra-picture prediction, (2) motion compensation, and (3) motion estimation).

425. The Dell '112 Products contain functionality for motion compensation where two or more motion vectors can be applied. Further, one or two motion vectors can be applied to the image processing process. The application of the motion vectors leads to uni-predictive or bi-predictive coding, respectively, where bi-predictive coding uses an averaged result of two predictions to form the final prediction.

Summary

Recommendation ITU-T H.265 | International Standard ISO/IEC 23008-2 represents an evolution of the existing video coding Recommendations (ITU-T H.261, ITU-T H.262, ITU-T H.263 and ITU-T H.264) and was developed in response to the growing need for higher compression of moving pictures for various applications such as Internet streaming, communication, videoconferencing, digital storage media and television broadcasting. It is also designed to enable the use of the coded video representation in a flexible manner for a wide variety of network environments. The use of this Recommendation | International Standard allows motion video to be manipulated as a form of computer data and to be stored on various storage media, transmitted and received over existing and future networks and distributed on existing and future broadcasting channels.

Series H: Audiovisual and Multimedia Systems- Infrastructure of Audiovisual Services – Coding of Moving Video, INTERNATIONAL TELECOMMUNICATIONS UNIONS - TU-T H.265, V.5 at I (February 2018).

426. The Dell '112 Products comprise a system wherein an intra-frame coding unit is configured to perform predictive coding on a set of pixels of a macroblock of pixels. Further, the predictive coding functionality uses a first group of reference pixels and a macroblock of pixels from the video frame. Specifically, the Dell Products, when selecting a temporal candidate for HEVC intra-frame encoding, default to the right bottom position just outside of the collocated prediction unit.

It can be seen from Fig. 5.4b that only motion vectors from spatial neighboring blocks to the left and above the current block are considered as spatial MVP candidates. This can be explained by the fact that the blocks to the right and below the current block are not yet decoded and hence, their motion data is not available. Since the co-located picture is a reference picture which is already decoded, it is possible to also consider motion data from the block at the same position, from blocks to the right of the co-located block or from the blocks below. In HEVC, the block to the bottom right and at the center of the current block have been determined to be the most suitable to provide a good temporal motion vector predictor (TMVP).

Benjamin Bross, *et al.*, *Inter-picture prediction in HEVC*, in HIGH EFFICIENCY VIDEO CODING (HEVC) at 119 (2014) (emphasis added);

427. Descriptions of the HEVC encoding process, which are implemented by the Dell ‘112 Products, state “for the temporal candidate, the right bottom position just outside of the collocated PU of the reference picture is used if it is available. Otherwise, the center position is used instead.” Gary J. Sullivan, *et al.*, *Overview of the High Efficiency Video Coding (HEVC) Standard*, IEEE TRANS. ON CIRCUIT AND SYSTEMS FOR VIDEO TECHNOLOGY at 13 (December 2012).

428. The Dell video encoder in the Dell ‘112 Products selects an image segment of a second video image corresponding to an image segment of a first video image. The image segment further has an image segment center.

429. The Dell ‘112 Products encode video data such that a predetermined search area (S) center is offset from the center of the image segment. The predetermined search area is called a partition and there are eight different partition modes in the H.265 standard, these partition modes are shown in the figure below. The last four partition modes are asymmetric, meaning their center is offset from the overall CU center.

Prediction Units

We have introduced the new transform sizes just after the picture partitioning to exploit the analogy between CU and TU trees, but before transform and quantization there's the prediction phase (inter or intra).
 A CU can be predicted using one of eight partition modes (see picture below).

Even if a CU contains one, two or four prediction units (PUs), it can be predicted using exclusively inter-frame or intra-frame prediction technique, furthermore Intra-coded CUs can use only the square partitions 2Nx2N or NxN. Inter-coded CUs can use both square and asymmetric partitions. A number of other limitations are applied to simplify signaling. For example, no 4x4 prediction is allowed in inter-prediction and 4x8 and 8x4 are allowed only in forward prediction (so not in b-frames). Tendentially inter-prediction stops at 8x8 level.

Fabio Sonnati, *H265 – Part I: Technical Overview*, VIDEO ENCODING & STREAMING TECHNOLOGIES WEBSITE (June 20, 2014) (emphasis added).

430. The figure below shows the syntax as well as the instructions for enabling the asymmetric partitions within the H.265 standard which is used by the Dell ‘112 Products.

max_transform_hierarchy_depth_intra specifies the maximum hierarchy depth for transform units of coding units coded in intra prediction mode. The value of max_transform_hierarchy_depth_intra shall be in the range of 0 to CtbLog2SizeY – MinTbLog2SizeY, inclusive.

scaling_list_enabled_flag equal to 1 specifies that a scaling list is used for the scaling process for transform coefficients. scaling_list_enabled_flag equal to 0 specifies that scaling list is not used for the scaling process for transform coefficients.

sps_scaling_list_data_present_flag equal to 1 specifies that the scaling_list_data() syntax structure is present in the SPS. sps_scaling_list_data_present_flag equal to 0 specifies that the scaling_list_data() syntax structure is not present in the SPS. When not present, the value of sps_scaling_list_data_present_flag is inferred to be equal to 0.

amp_enabled_flag equal to 1 specifies that asymmetric motion partitions, i.e., PartMode equal to PART_2NxN_U, PART_2NxN_D, PART_nLx2N or PART_nRx2N, may be used in coding tree blocks. amp_enabled_flag equal to 0 specifies that asymmetric motion partitions cannot be used in coding tree blocks.

sample_adaptive_offset_enabled_flag equal to 1 specifies that the sample adaptive offset process is applied to the reconstructed picture after the deblocking filter process. sample_adaptive_offset_enabled_flag equal to 0 specifies that the sample adaptive offset process is not applied to the reconstructed picture after the deblocking filter process.

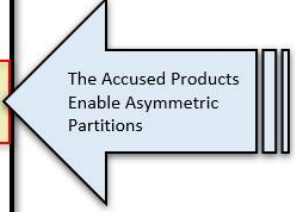

High Efficiency Video Coding, SERIES H: AUDIOVISUAL AND MULTIMEDIA SYSTEMS: INFRASTRUCTURE OF AUDIOVISUAL SERVICES – CODING OF MOVING VIDEO REC. ITU-T H.265 at 76 (April 2015) (annotation added).

431. The Dell ‘112 Products receive encoded video data that is encoded using intra-frame coding. Specifically, the encoded video stream received by the Dell ‘112 Products is coded using a reference group of pixels in the video frame. Intra-frame prediction used in the encoded video data received by the Dell ‘112 Products allows a transform block to span across multiple

prediction blocks for intra-frame-picture predicted coding units to maximize the potential coding efficiency benefits of the quadtree-structured transform block partitioning.

The basic source-coding algorithm is a hybrid of interpicture prediction to exploit temporal statistical dependences, intrapicture prediction to exploit spatial statistical dependences, and transform coding of the prediction residual signals to further exploit spatial statistical dependences.

G. J. Sullivan, J.-R. Ohm, W.-J. Han, and T. Wiegand, *Overview of the High Efficiency Video Coding (HEVC) standard*, IEEE TRANS. CIRCUITS SYST. VIDEO TECHNOL., vol. 22, no. 12, p. 1654 (December 2012) (emphasis added).

432. The Dell '112 Products comprise functionality for retrieving image motion data related to the search area. Specifically, the Dell '112 Products retrieve data relating to the motion search area. The data, which includes the motion vector index, is sent from the encoder and retrieved by the decoder.

Since inter-picture prediction typically compensates for the motion of real-world objects between pictures of a video sequence, it is also referred to as motion-compensated prediction. While intra-picture prediction exploits the spatial redundancy between neighboring blocks inside a picture, motion-compensated prediction utilizes the large amount of temporal redundancy between pictures. In either case, the resulting prediction error, which is formed by taking the difference between the original block and its prediction, is transmitted using transform coding, which exploits the spatial redundancy inside a block and consists of a decorrelating linear transform, scalar quantization of the transform coefficients and entropy coding of the resulting transform coefficient levels.

Heiko Schwarz, Thomas Schierl, Detlev Marpe, *Block Structures and Parallelism Features in HEVC*, in HEVC, HIGH EFFICIENCY VIDEO CODING (HEVC) at 49 (September 2014) (emphasis added).

433. Dell '112 Products comprise an inter-frame coding unit that is configured to perform predictive coding on the rest of the macroblock of pixels using a second group of reference pixels. The second group of reference pixels that are used to perform inter-frame coding are drawn from at least one other video frame. The image data processed by the Dell '112 Products is encoded using inter-picture prediction that makes use of the temporal correlation between pictures to derive a motion-compensated prediction (MCP) for a block of image samples. For this block-based motion compensated prediction, an image is divided into rectangular blocks. Assuming

homogeneous motion inside one block, and that moving objects are larger than one block, for each block, a corresponding block in a previously decoded picture can be found that serves as a predictor (a second image). Both the first and second images are retrieved by the Dell '112 Product from storage such as on chip memory. The general concept of inter-frame-based encoding using motion-compensated prediction based on a translational motion model is illustrated below.

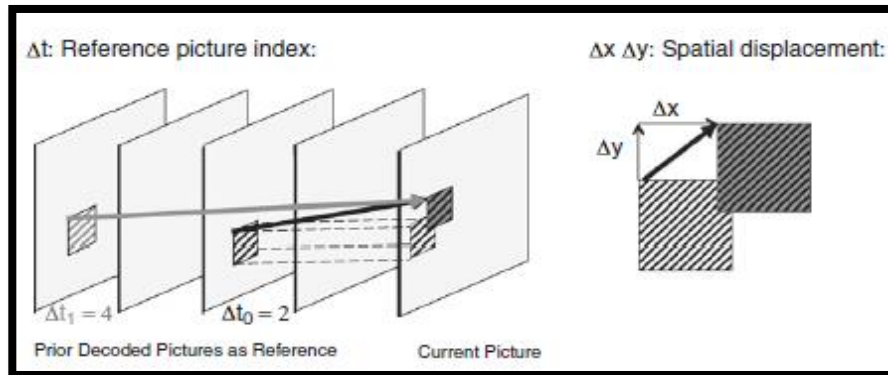

Benjamin Bross, *Inter-Picture Prediction In HEVC*, HIGH EFFICIENCY VIDEO CODING (HEVC) at 114 (September 2014).

434. On information and belief, by complying with the HEVC standard, the Dell devices – such as the Dell '112 Products – necessarily infringe the '112 patent. The mandatory sections of the HEVC standard require the elements required by certain claims of the '112 patent, including but not limited to claim 11 of the '112 patent. *High Efficiency Video Coding, SERIES H: AUDIOVISUAL AND Multimedia SYSTEMS: INFRASTRUCTURE OF AUDIOVISUAL SERVICES – CODING OF MOVING VIDEO REC. ITU-T H.265* (February 2018) (The following sections of the HEVC Standard are relevant to Dell's infringement of the '112 patent: “8.3.2 Decoding process for reference picture set;” “8.5.4 Decoding process for the residual signal of coding units coded in inter prediction mode;” “8.6 Scaling, transformation and array construction process prior to deblocking filter process;” “8.5.2 Inter prediction process;” “8.5.3 Decoding process for prediction

units in inter prediction mode;” and “8.7.2 Deblocking filter process;” “8.7.3 Sample adaptive offset process.”).

435. On information and belief, one or more Dell subsidiaries and/or affiliates use the Dell ‘112 Products in regular business operations.

436. On information and belief, one or more of the Dell ‘112 Products include technology for video compression.

437. On information and belief, Dell has directly infringed and continues to directly infringe the ‘112 patent by, among other things, making, using, offering for sale, and/or selling technology for video compression, including but not limited to the Dell ‘112 Products.

438. On information and belief, one or more of the Dell ‘112 Products perform predictive coding on a macroblock of a video frame such that a set of pixels of the macroblock is coded using some of the pixels from the same video frame as reference pixels and the rest of the macroblock is coded using reference pixels from at least one other video frame.

439. On information and belief, one or more of the Dell ‘112 Products include a system for video compression comprising an intra-frame coding unit configured to perform predictive coding on a set of pixels of a macroblock of pixels using a first group of reference pixels, the macroblock of pixels and the first group of reference pixels being from a video frame.

440. On information and belief, one or more of the Dell ‘112 Products include a system for video compression comprising an inter-frame coding unit configured to perform predictive coding on the rest of the macroblock of pixels using a second group of reference pixels, the second group of reference pixels being from at least one other video frame.

441. On information and belief, the Dell ‘112 Products are available to businesses and individuals throughout the United States.

442. On information and belief, the Dell ‘112 Products are provided to businesses and individuals located in the Southern District of New York.

443. By making, using, testing, offering for sale, and/or selling products and services for interpolating a pixel during the interlacing of a video signal, including but not limited to the Dell ‘112 Products, Dell has injured Dynamic Data and is liable to the Plaintiff for directly infringing one or more claims of the ‘112 patent, including at least claim 11 pursuant to 35 U.S.C. § 271(a).

444. On information and belief, Dell also indirectly infringes the ‘112 patent by actively inducing infringement under 35 U.S.C. § 271(b).

445. Dell has had knowledge of the ‘112 patent since at least service of the Original Complaint in this case or shortly thereafter, and on information and belief, Dell knew of the ‘112 patent and knew of its infringement, including by way of this lawsuit.

446. On information and belief, Dell intended to induce patent infringement by third-party customers and users of the Dell ‘112 Products and had knowledge that the inducing acts would cause infringement or was willfully blind to the possibility that its inducing acts would cause infringement. Dell specifically intended and was aware that the normal and customary use of the accused products would infringe the ‘112 patent. Dell performed the acts that constitute induced infringement, and would induce actual infringement, with knowledge of the ‘112 patent and with the knowledge that the induced acts would constitute infringement. For example, Dell provides the Dell ‘112 Products that have the capability of operating in a manner that infringe one or more of the claims of the ‘112 patent, including at least claim 11, and Dell further provides documentation and training materials that cause customers and end users of the Dell ‘112 Products to utilize the products in a manner that directly infringe one or more claims of the ‘112 patent.²³²

²³² See, e.g., *Dell G7 15*, SETUP AND SPECIFICATIONS (2018); *Alienware Graphics Amplifier*, USER’S GUIDE (2014); *Alienware Aurora R8*, SETUP AND SPECIFICATIONS (2018); *Inspiron 15*

By providing instruction and training to customers and end-users on how to use the Dell ‘112 Products in a manner that directly infringes one or more claims of the ‘112 patent, including at least claim 11, Dell specifically intended to induce infringement of the ‘112 patent. On information and belief, Dell engaged in such inducement to promote the sales of the Dell ‘112 Products, e.g., through Dell user manuals, product support, marketing materials, and training materials to actively induce the users of the accused products to infringe the ‘112 patent. Accordingly, Dell has induced and continues to induce users of the accused products to use the accused products in their ordinary and customary way to infringe the ‘112 patent, knowing that such use constitutes infringement of the ‘112 patent.

447. The ‘112 patent is well-known within the industry as demonstrated by multiple citations to the ‘112 patent in published patents and patent applications assigned to technology companies and academic institutions. Dell is utilizing the technology claimed in the ‘112 patent without paying a reasonable royalty. Dell is infringing the ‘112 patent in a manner best described as willful, wanton, malicious, in bad faith, deliberate, consciously wrongful, flagrant, or characteristic of a pirate.

448. To the extent applicable, the requirements of 35 U.S.C. § 287(a) have been met with respect to the ‘112 patent.

449. As a result of Dell’s infringement of the ‘112 patent, Dynamic Data has suffered monetary damages, and seeks recovery in an amount adequate to compensate for Dell’s infringement, but in no event less than a reasonable royalty for the use made of the invention by Dell together with interest and costs as fixed by the Court.

7000 Gaming, SERVICE MANUAL (2017-2018); XPS 13, SETUP AND SPECIFICATIONS (2017); Dell Latitude 5420/E5420/E5420m, OWNER’S MANUAL (2011); Alienware M17x R4, OWNER’S MANUAL (2012).

COUNT X
INFRINGEMENT OF U.S. PATENT NO. 7,894,529

450. Dynamic Data references and incorporates by reference the preceding paragraphs of this Complaint as if fully set forth herein.

451. Dell designs, makes, uses, sells, and/or offers for sale in the United States products and/or services for determining motion vectors that are each assigned to individual image regions.

452. Dell designs, makes, sells, offers to sell, imports, and/or uses Dell devices that contain H.265 video compression functionality, including but not limited to Dell desktops, laptops, and all-in-one devices including the following exemplary models: Dell G3 3579, Dell G3 3779, Dell G5 15 5587, Dell G7 15 7588, Dell Precision 5530, Inspiron 14 Gaming 7466, Inspiron 14 Gaming 7467, Inspiron 15 Gaming 7566, Inspiron 15 Gaming 7567, Inspiron 15 Gaming 7577, Inspiron 7472, Inspiron 7572, Inspiron G3 3579, Inspiron G3 3779, Latitude 3190, Latitude 3190 2-in-1, Latitude 5420, Latitude 5424, Latitude 5491, Latitude 5591, Latitude 7424, Optiplex 3060, Optiplex 5060, Optiplex 5260 AIO, Optiplex 7060, Optiplex 7460 AIO, Optiplex 7760 AIO, Optiplex XE3, Precision 3430, Precision 3430 XL Tower, Precision 3530, Precision 3630, Precision 3630 XL Tower, Precision 3930 Rack, Precision 3930 XL RACK, Precision 5510, Precision 5520, Precision 5530, Precision 7530, Precision 7730, Precision M3800, XPS 13 9360, XPS 13 9365 2-in-1, XPS 13 9370, XPS 15 9550, XPS 15 9560, XPS 15 9570, XPS 15 9575 2-in-1, XPS Notebook 9365, XPS Notebook 9530, XPS Notebook 9550, XPS Notebook 9560, and, XPS Notebook 9570, Alienware 15, Alienware 15 R2, Alienware 15 R3, Alienware 15 R4, Alienware 17, Alienware 17 R2, Alienware 17 R3, Alienware 17 R4, Alienware 17 R5, Alienware 18, Alienware Area 51, Alienware Area-51 ALX, Alienware Area-51 R2, Alienware Area-51 R4 and R5, Alienware Area-51 Threadripper Edition R3 and R6, Alienware Area-51 Threadripper Edition R7, Alienware Aurora, Alienware Aurora ALX, Alienware Aurora R2, Alienware Aurora

R3, Alienware Aurora R4, Alienware Aurora R5, Alienware Aurora R6, Alienware Aurora R7, Alienware Aurora R8, Alienware m15, Alienware M15x, Alienware M17x, Alienware M17x R2, Alienware M17x R3, Alienware M17x R4, Alienware M18x, Alienware M18x R2, Alienware X51, Alienware X51 R2, and Alienware X51 R3 (collectively, the “Dell ‘529 Product(s)”).

453. The Dell ‘529 Products perform video processing compliant with the HEVC standard. *See e.g., Dell Desktop Support, DELL SUPPORT WEBSITE, available at: <https://www.dell.com/support/home/us/en/19/products/desktop>; Dell Laptop Support, DELL SUPPORT WEBSITE, available at: <https://www.dell.com/support/home/us/en/19/products/laptop>*

454. The below table shows Dell ‘529 Products that contain the infringing HEVC compliant video processing technology.

Exemplar Dell Models	Graphics Processing Unit (GPU)	HEVC Decode/Encode ²³³
Dell G3 3579	NVIDIA GeForce GTX 1050 Ti ²³⁴	Yes
Dell G3 3779	NVIDIA GeForce GTX 1060 w/ Max Q ²³⁵	Yes
Dell G5 15 5587	NVIDIA GeForce GTX 1060 w/ Max Q ²³⁶	Yes
Dell G7 15 7588	NVIDIA GeForce GTX 1060 w/ Max Q ²³⁷	Yes
Inspiron 14 Gaming 7466	Intel HD Graphics 530 ²³⁸	Yes
Inspiron 14 Gaming 7467	Intel HD Graphics 630 ²³⁹	Yes

²³³ *NVIDIA Video Encode And Decode GPU Support Matrix*, NVIDIA DEVELOPER WEBSITE, available at: <https://developer.nvidia.com/video-encode-decode-gpu-support-matrix> (showing support for HEVC in NVIDIA Graphics cards); *Intel Product Matrix*, INTEL WEBSITE, available at: <https://www.intel.com/content/www/us/en/products> (showing HEVC Support); *Intel Graphics Product Specifications*, INTEL WEBSITE, available at: <https://www.intel.com/content/www/us/en/architecture-and-technology/visual-technology/graphics-overview.html>.

²³⁴ *Dell Model G3 3579*, DELL WEBSITE, available at: <https://www.dell.com/en-us/work/shop/dell-laptops-and-notebooks/dell-g3-15-gaming-laptop/spd/g-series-15-3579-laptop>

²³⁵ *Dell Model G3 3779*, DELL WEBSITE, available at: <https://www.dell.com/en-us/shop/dell-laptops/dell-g3-17-gaming/spd/g-series-17-3779-laptop>

²³⁶ *Dell Model G5 15 5587*, DELL WEBSITE, available at: <https://www.dell.com/en-us/shop/dell-laptops/dell-g5-15-gaming/spd/g-series-15-5587-laptop>

²³⁷ *Dell Model G7 15 7588*, DELL WEBSITE, available at: <https://www.dell.com/en-us/shop/dell-laptops/dell-g7-15-gaming/spd/g-series-15-7588-laptop>

²³⁸ *Dell Inspiron 14 Gaming Setup and Specifications*, DELL MANUAL MODEL NO. INSPIRON 14-7466 at 18 (2016).

²³⁹ *Dell Inspiron 14 7000 Gaming Series Setup and Specifications*, DELL SPECIFICATIONS MODEL NO. INSPIRON 14-7467 at 18 (2016)

Inspiron 15 Gaming 7566	Intel HD Graphics 530 (Integrated) / NVIDIA GeForce GTX630M (Discrete) ²⁴⁰	Yes
Inspiron 15 Gaming 7567	NVIDIA GeForce GTX 1050Ti with 4GB GDDR5 / NVIDIA GeForce GTX 1050 with 4GB GDDR5 ²⁴¹	Yes
Inspiron 15 Gaming 7577	Intel HD Graphics 630 (Integrated) / NVIDIA GeForce GTX 1050/ GTX 1050 Ti/ GTX 1060 Max-Q (Discrete) ²⁴²	Yes
Inspiron 5457	Intel HD Graphics 520 (integrated) / NVIDIA GeForce 930M (Discrete) ²⁴³	Yes
Inspiron 5458	Intel HD Graphics 4400/4500 (integrated) / NVIDIA GeForce 920M (discrete) ²⁴⁴	Yes
Inspiron 5557	Intel HD Graphics 520 (integrated) / NVIDIA GeForce 930M (discrete) ²⁴⁵	Yes
Inspiron 5558	Intel HD Graphics 4400/4500 (integrated) / NVIDIA GeForce 920M (discrete) ²⁴⁶	Yes
Inspiron 5587	NVIDIA GeForce GTX 1060 Max-Q ²⁴⁷	Yes
Inspiron 5758	Intel HD Graphics 4400/4500 (integrated) / NVIDIA GeForce 920M (discrete) ²⁴⁸	Yes
Inspiron 7447	Intel Iris Pro Graphic 5200 (integrated) / NVIDIA GeForce GTX 850M (discrete) ²⁴⁹	Yes
Inspiron 7460	Intel HD Graphics 610/620/635 (integrated)/ NVIDIA GeForce 940M ²⁵⁰	Yes
Inspiron 7466	Intel HD Graphics 530 (integrated) / NVIDIA GeForce GTX 950M ²⁵¹	Yes
Alienware Area 51	NVIDIA GeForce RTX 2080 Ti OC with 11GB GDDR6 ²⁵²	Yes
Alienware Area-51 R2	NVIDIA® GeForce GTX ²⁵³	Yes

²⁴⁰ *Dell Inspiron 15 Gaming Setup and Specifications*, DELL MANUAL MODEL NO. 15-7566 at 18 (2016)

²⁴¹ *Dell Inspiron Model 7567*, DELL WEBSITE, available at: <https://www.dell.com/us/dfh/p/inspiron-15-7567-laptop/pd>

²⁴² *Dell Inspiron 15 7000 Gaming Setup and Specifications*, DELL MANUAL MODEL NO. INSPIRON 15-7577 at 23 (2018).

²⁴³ *Dell Inspiron 14 5000 Series Specification*, DELL SPECIFICATIONS MODEL NO. INSPIRON 14-5457 at 12 (2015).

²⁴⁴ *Dell Inspiron 14 5000 Series Specification*, DELL SPECIFICATIONS MODEL NO. INSPIRON 14-5458 at 12 (2015).

²⁴⁵ *Dell Inspiron 14 5000 Series Specification*, DELL SPECIFICATIONS MODEL NO. INSPIRON 14-5557 at 12 (2015).

²⁴⁶ *Dell Inspiron 14 5000 Series Specification*, DELL SPECIFICATIONS MODEL NO. INSPIRON 14-5558 at 12 (2015).

²⁴⁷ *Dell Inspiron Model 5587*, DELL WEBSITE, available at: <https://www.dell.com/en-us/shop/dell-laptops/dell-g5-15-gaming/spd/g-series-15-5587-laptop>

²⁴⁸ *Dell Inspiron 17 5000 Series Specification*, DELL SPECIFICATIONS MODEL NO. INSPIRON 17-5758 at 12 (2015).

²⁴⁹ *Dell Inspiron 14 7000 Series Specification*, DELL SPECIFICATIONS MODEL NO. INSPIRON 7447 at 12 (2014).

²⁵⁰ *Dell Inspiron 14 7000 Setup and Specification*, DELL MANUAL MODEL NO. INSPIRON 14-7460 at 18 (2018)

²⁵¹ *Dell Inspiron 14 Gaming Setup and Specifications*, DELL MANUAL MODEL NO. INSPIRON 14-7466 at 18 (2016).

²⁵² *Dell Alienware Specifications*, DELL WEBSITE, available at: <https://www.dell.com/en-us/shop/dell-desktop-computers/alienware-area-51/spd/alienware-area51-r5>

²⁵³ *Dell Alienware Specifications*, DELL WEBSITE, available at: <https://www.dell.com/en-us/shop/cty/pdp/spd/alienware-area51-r2>

Alienware Area-51 R4/R5	NVIDIA® GeForce GTX ²⁵⁴	Yes
Alienware Area-51 Threadripper R3/R6	NVIDIA GeForce GTX 1080 ²⁵⁵	Yes
Alienware Area-51 Threadripper Edition R7	Dual NVIDIA® GeForce® RTX 2080 Ti OC ²⁵⁶	Yes
Alienware Aurora	NVIDIA® GeForce® RTX 2080 Ti OC with 11GB GDDR6 ²⁵⁷	Yes

455. Dell documentation states that the Dell ‘529 Products are compliant with the HEVC standard as shown in the following excerpts.

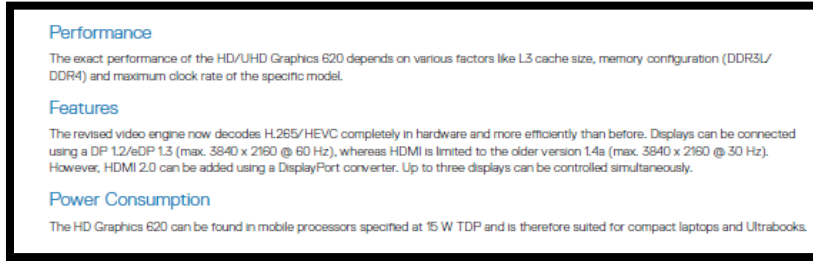

DELL LATITUDE 5420 RUGGED OWNER’S MANUAL at 44 (2015) (“The revised video engine now decodes H.265/HEVC completely in hardware and more efficiently than before.”).

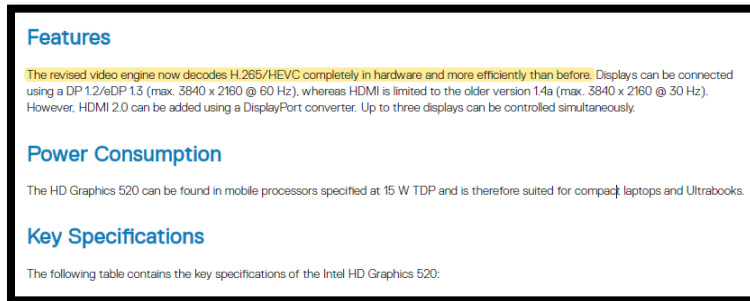

DELL VOSTRO 14-3468 OWNER’S MANUAL at 55 (2018) (annotation added) (“The revised video engine now decodes H.265/HEVC completely in hardware and more efficiently than before.”).

²⁵⁴ Dell Alienware Specifications, DELL WEBSITE, available at: <https://www.dell.com/en-us/shop/dell-desktop-computers/alienware-area-51-gaming-desktop/spd/alienware-area51-r4>

²⁵⁵ Dell Alienware Specifications, DELL WEBSITE, available at: <https://www.dell.com/en-us/shop/dell-desktop-computers/alienware-area-51-threadripper-edition/spd/alienware-area51-r6>

²⁵⁶ Dell Alienware Specifications, DELL WEBSITE, available at: <https://www.dell.com/en-us/shop/desktops/area-51-threadripper/spd/alienware-area51-r7>

²⁵⁷ Dell Alienware Specifications, DELL WEBSITE, available at: <https://www.dell.com/en-us/shop/dell-desktop-computers/alienware-aurora/spd/alienware-aurora-r7-desktop>



DELL PRODUCT QUICK REFERENCE MATRIX Q4 2018 at 17 (2018) (“New HEVC 10-bit and VP9 decode”).

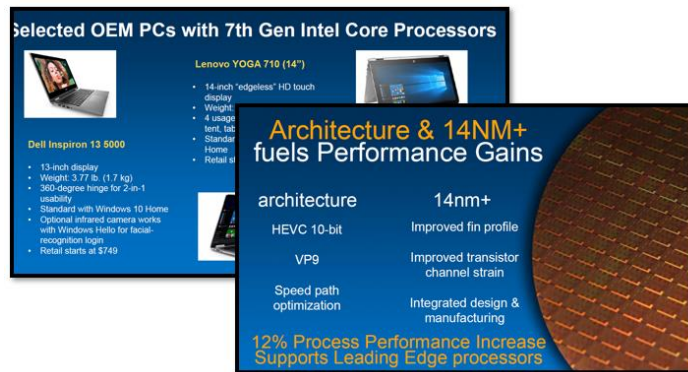

David Bradshaw, *7th Generation Intel Core Processor*, INTEL PRESENTATION at 3 & 12 (2016).

456. The circuitry of the Dell ‘529 Products contain multiple inputs for receiving frame-based encoded video information. Specifically, the Dell ‘529 Products include inputs for receiving and decoding HEVC video data.

457. The Dell ‘529 Products incorporate a decoding unit for decoding the frame of the received video data. The decoding utilizes a second frame recovery unit that is a decoding motion vector. Specifically, the encoding and decoding process for video data received by the Dell ‘529 Products use inter-picture prediction wherein motion data comprises the selection of a reference frame and motion vectors to be applied in predicting the samples of each block.

458. On information and belief, by complying with the HEVC standard, the Dell devices – such as the Dell ‘529 Products – necessarily infringe the ‘529 patent. Mandatory sections of the HEVC standard require the elements required by certain claims of the ‘529 patent, including but not limited to claim 1. *High Efficiency Video Coding*, SERIES H: AUDIOVISUAL AND Multimedia

SYSTEMS: INFRASTRUCTURE OF AUDIOVISUAL SERVICES – CODING OF MOVING VIDEO REC. ITU-T H.265 (February 2018). The following sections of the HEVC Standard are relevant to Dell’s infringement of the ‘529 patent: “3.110 Prediction Unit Definition;” “6.3.2 Block and quadtree structures;” “6.3.3 Spatial or component-wise partitioning;” “6.4.2 Derivation process for prediction block availability;” “7.3.8.5 Coding unit syntax;” “7.3.8.6 Prediction unit syntax;” “8.3.2 Decoding process for reference picture set;” “8.5.4 Decoding process for the residual signal of coding units coded in inter prediction mode;” “8.6 Scaling, transformation and array construction process prior to deblocking filter process;” “8.5.2 Inter prediction process;” “8.5.3 Decoding process for prediction units in inter prediction mode;” and “8.7.2 Deblocking filter process.”

459. On information and belief, the Dell ‘529 Products comply with the HEVC standard, which requires determining motion vectors assigned to individual image regions of an image.

The decoding process for prediction units in inter prediction mode consists of the following ordered steps:

1. The derivation process for motion vector components and reference indices as specified in clause 8.5.3.2 is invoked with the luma coding block location (x_{Cb} , y_{Cb}), the luma prediction block location (x_{B1} , y_{B1}), the luma coding block size block n_{CbS} , the luma prediction block width n_{PbW} , the luma prediction block height n_{PbH} and the prediction unit index $partIdx$ as inputs, and the luma motion vectors $mvL0$ and $mvL1$, when $ChromaArrayType$ is not equal to 0, the chroma motion vectors $mvCL0$ and $mvCL1$, the reference indices $refIdxL0$ and $refIdxL1$ and the prediction list utilization flags $predFlagL0$ and $predFlagL1$ as outputs.

High Efficiency Video Coding, Series H: Audiovisual And Multimedia Systems: Infrastructure Of Audiovisual Services – Coding Of Moving Video Rec. ITU-T H.265 at § 8.5.3.1 (February 2018).

460. On information and belief, Dell has directly infringed and continues to directly infringe the ‘529 patent by, among other things, making, using, offering for sale, and/or selling technology for implementing a motion estimation technique that assigns at least one motion vector to each of the image blocks and generating a modification motion vector for at least the first image block.

461. On information and belief, the encoded video stream received by the Dell ‘529 Products is encoded using inter-picture prediction that makes use of the temporal correlation between pictures to derive a motion-compensated prediction (MCP) for a block of image samples. For this block-based motion compensated prediction, a video picture is divided into rectangular blocks. Assuming homogeneous motion inside one block, and that moving objects are larger than one block, for each block, a corresponding block in a previously decoded picture can be found that serves as a predictor. The general concept of inter-frame-based encoding using motion-compensated prediction based on a translational motion model is illustrated below.

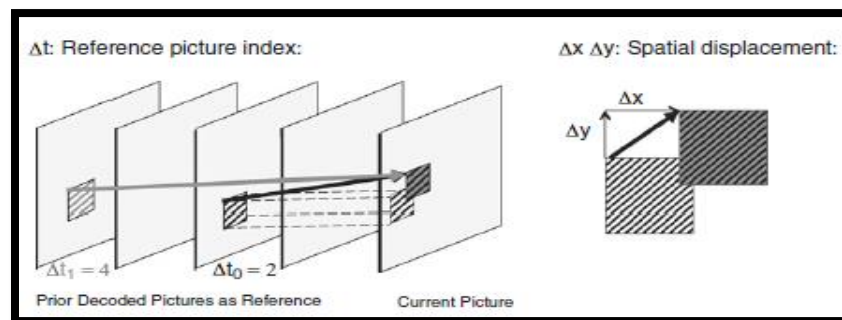

Benjamin Bross, *Inter-Picture Prediction In HEVC*, HIGH EFFICIENCY VIDEO CODING (HEVC) at 114 (September 2014).

462. On information and belief, the Dell ‘529 Products perform the step of selecting a second image block where the motion vector that is assigned to the first image block passes. Specifically, the Dell ‘529 Products, in the use of inter-picture prediction, look at two or more blocks in different frames wherein the vector passes through both the first and second image block. The following excerpts from documentation relating the video estimation technique used by the Dell ‘529 Products explains how HEVC uses motion estimation to determine a temporal intermediate position between two images wherein two image blocks are selected that have a motion vector passing in both the first and second image block.

One way of achieving high video compression is to predict pixel values for a frame based on prior and succeeding pictures in the video. Like its predecessors, H.265 features the ability to predict pixel values between pictures, and in particular, to specify in which order pictures are coded and which pictures are predicted from which. The coding order is specified for Groups Of Pictures (GOP), where a number of pictures are grouped together and predicted from each other in a specified order. The pictures available to predict from, called reference pictures, are specified for every individual picture.

Johan Bartelmeß, *Compression Efficiency of Different Picture Coding Structures in High Efficiency Video Coding (HEVC)*, UPTEC STS 16006 at 4 (March 2016) (emphasis added).

463. On information and belief, the Dell ‘529 Products receive encoded video data that is encoded using inter-frame coding. Specifically, the encoded video stream received by the Dell ‘529 Products is coded using its predecessor frame. Inter-prediction used in the encoded video data received by the Dell ‘529 Products allows a transform block to span across multiple prediction blocks for inter-picture predicted coding units to maximize the potential coding efficiency benefits of the quadtree-structured transform block partitioning.

The basic source-coding algorithm is a hybrid of interpicture prediction to exploit temporal statistical dependences, intrapicture prediction to exploit spatial statistical dependences, and transform coding of the prediction residual signals to further exploit spatial statistical dependences.

G. J. Sullivan, J.-R. Ohm, W.-J. Han, and T. Wiegand, *Overview of the High Efficiency Video Coding (HEVC) standard*, IEEE TRANS. CIRCUITS SYST. VIDEO TECHNOL., Vol. 22, No. 12, p. 1654 (December 2012) (emphasis added).

464. The following excerpt from an article describing the architecture of the video stream received by the Dell ‘529 Products describes the functionality wherein the second encoded frame of the video data is dependent on the encoding of a first frame. “HEVC inter prediction uses motion vectors pointing to one reference frame . . . to predict a block of pixels.”

HEVC inter prediction uses motion vectors pointing to one reference frame (uni-prediction) or two reference frames (bi-prediction) to predict a block of pixels. The size of the predicted block, called Prediction Unit (PU), is determined by the Coding Unit (CU) size and its partitioning mode. For example, a 32×32 CU with $2N \times N$ partitioning is split into two PUs of size 32×16 , or a 16×16 CU with $nL \times 2N$ partitioning is split into 4×16 and 12×16 PUs.

Mehul Tikekar, *et al.*, *Decoder Hardware Architecture for HEVC*, HIGH EFFICIENCY VIDEO CODING (HEVC) (September 2014).

465. On information and belief, any implementation of the HEVC standard infringes the ‘529 patent as every possible implementation of the standard requires: determining at least a second image block through which the motion vector assigned to the first image block at least partially passes; generating the modified motion vector as a function of a motion vector assigned to at least the second image block; and assigning the modified motion vector as the motion vector to the first image block. Further, the functionality of the motion estimation process in HEVC uses “motion vector[s]: A two-dimensional vector used for *inter prediction* that provides an offset from the coordinates in the decoded picture to the coordinates in a reference picture,” as defined in definition 3.83 of the *ITU-T H.265 Series H: Audiovisual and Multimedia Systems* (2018) (emphasis added); *see also, e.g.*, Gary J. Sullivan, Jens-Rainer Ohm, Woo-Jin Han, and Thomas Wiegand, *Overview of the High Efficiency Video Coding (HEVC) Standard*, published in IEEE TRANSACTIONS ON CIRCUITS AND SYSTEMS FOR VIDEO TECHNOLOGY, Vol. 22, No. 12 at 1650 (December 2012) (“The encoder and decoder generate identical inter picture prediction signals by applying motion compensation (MC) using the MV and mode decision data.”).

466. The motion estimation done by the Dell ‘529 Products is done through a PU matching method where the motion vector represents the displacement between the current PU in the current frame and the matching PU in the reference frame.

Motion estimation compares the current prediction unit (PU) with the spatially neighboring PUs in the reference frames, and chooses the one with the least difference

to the current PU. The displacement between the current PU and the matching PU in the reference frames is signaled using a motion vector.

Sung-Fang Tsai, *et al.*, *Encoder Hardware Architecture for HEVC*, HIGH EFFICIENCY VIDEO CODING (HEVC) at 347 (September 2014) (emphasis added).

467. On information and belief, the Dell ‘529 Products perform the step of assigning the modified motion vector as the motion vector to the first image block. Specifically, the Dell ‘529 Products, through the use of AMVP and Merge Mode, select the modified motion vector and assign it to a first block. The displacement between the current prediction unit and the matching prediction unit in the second image (reference image) is signaled using a motion vector. Further, the Dell ‘529 Products take the modified motion vector “computed from corresponding regions of previously decoded pictures” and transmit the residual.

A block-wise prediction residual is computed from corresponding regions of previously decoded pictures (inter-picture motion compensated prediction) or neighboring previously decoded samples from the same picture (intra-picture spatial prediction). The residual is then processed by a block transform, and the transform coefficients are quantized and entropy coded. Side information data such as motion vectors and mode switching parameters are also encoded and transmitted.

Standardized Extensions of High Efficiency Video Coding (HEVC), IEEE JOURNAL OF SELECTED TOPICS IN SIGNAL PROCESSING, Vol. 7, No. 6 at 1002 (December 2013) (emphasis added).

468. On information and belief, the Dell ‘529 Products transmit into the bitstream the candidate index of motion vectors. HEVC documentation states that the coding process will “pick up the MV [motion vector] to use as an estimator using the index sent by the encoder in the bitstream.”

Inter prediction

For motion vector prediction HEVC has two reference lists: L0 and L1. They can hold 16 references each, but the maximum total number of unique pictures is 8. Multiple instances of the same ref frame can be stored with different weights. HEVC motion estimation is much more complex than in AVC. It uses list indexing. There are two main prediction modes: Merge and Advanced MV. Each PU can use one of those methods and can have forward (a MV) or bi-directional prediction (2 MV). In Advanced MV mode a list of candidates MV is created (spatial and temporal candidates picked with a complex, probabilistic logic), when the list is created only the best candidate index is transmitted in the bitstream plus the MV delta (the difference between the real MV and the prediction). On the other side, the decoder will build and update continuously the same candidate list using the exact same rules used by the encoder and will pick-up the MV to use as estimator using the index sent by the encoder in the bitstream. The merge mode is similar, the main difference is that the candidates' list is calculated from neighboring MV and is not added to a delta MV. It is the equivalent of "skip" mode in AVC.

Fabio Sonnati, *H265 – Part I: Technical Overview*, VIDEO ENCODING & STREAMING TECHNOLOGIES WEBSITE (June 20, 2014) (emphasis added).

469. On information and belief, one or more Dell subsidiaries and/or affiliates use the Dell '529 Products in regular business operations.

470. On information and belief, Dell has directly infringed and continues to directly infringe the '529 Patent by, among other things, making, using, offering for sale, and/or selling technology for determining motion vectors that are each assigned to individual image regions, including but not limited to the Dell '529 Products.

471. On information and belief, one or more of the Dell '529 Products include technology for determining motion vectors that are each assigned to individual image regions.

472. On information and belief, one or more of the Dell '529 Products enable an increase in the resolution of video and image signals during the motion estimation process.

473. On information and belief, one or more of the Dell '529 Products perform a method for determining motion vectors which are assigned to individual image regions of an image.

474. On information and belief, one or more of the Dell '529 Products perform a method wherein an image is subdivided into a number of image blocks, and a motion estimation technique is implemented to assign at least one motion vector to each of the image blocks where a modified motion vector is generated for at least a first image block.

475. On information and belief, one or more of the Dell ‘529 Products perform a method that determines at least a second image block through which the motion vector assigned to the first image block at least partially passes.

476. On information and belief, one or more of the Dell ‘529 Products perform a method that generates the modified motion vector as a function of a motion vector assigned to at least the second image block.

477. On information and belief, one or more of the Dell ‘529 Products perform a method that assigns the modified motion vector as the motion vector to the first image block.

478. On information and belief, the Dell ‘529 Products are available to businesses and individuals throughout the United States.

479. On information and belief, the Dell ‘529 Products are provided to businesses and individuals located in the Southern District of New York.

480. By making, using, testing, offering for sale, and/or selling products and services for interpolating a pixel during the interlacing of a video signal, including but not limited to the Dell ‘529 Products, Dell has injured Dynamic Data and is liable to the Plaintiff for directly infringing one or more claims of the ‘529 patent, including at least claim 1 pursuant to 35 U.S.C. § 271(a).

481. On information and belief, Dell also indirectly infringes the ‘529 patent by actively inducing infringement under 35 U.S.C. § 271(b).

482. Dell has had knowledge of the ‘529 patent since at least service of the Original Complaint in this case or shortly thereafter, and on information and belief, Dell knew of the ‘529 patent and knew of its infringement, including by way of this lawsuit.

483. On information and belief, Dell intended to induce patent infringement by third-party customers and users of the Dell ‘529 Products and had knowledge that the inducing acts

would cause infringement or was willfully blind to the possibility that its inducing acts would cause infringement. Dell specifically intended and was aware that the normal and customary use of the accused products would infringe the '529 patent. Dell performed the acts that constitute induced infringement, and would induce actual infringement, with knowledge of the '529 patent and with the knowledge that the induced acts would constitute infringement. For example, Dell provides the Dell '529 Products that have the capability of operating in a manner that infringe one or more of the claims of the '529 patent, including at least claim 1, and Dell further provides documentation and training materials that cause customers and end users of the Dell '529 Products to utilize the products in a manner that directly infringe one or more claims of the '529 patent.²⁵⁸ By providing instruction and training to customers and end-users on how to use the Dell '529 Products in a manner that directly infringes one or more claims of the '529 patent, including at least claim 1, Dell specifically intended to induce infringement of the '529 patent. On information and belief, Dell engaged in such inducement to promote the sales of the Dell '529 Products, e.g., through Dell user manuals, product support, marketing materials, and training materials to actively induce the users of the accused products to infringe the '529 patent. Accordingly, Dell has induced and continues to induce users of the accused products to use the accused products in their ordinary and customary way to infringe the '529 patent, knowing that such use constitutes infringement of the '529 patent.

484. The '529 patent is well-known within the industry as demonstrated by multiple citations to the '529 patent in published patents and patent applications assigned to technology

²⁵⁸ See, e.g., *Dell G7 15, SETUP AND SPECIFICATIONS* (2018); *Alienware Graphics Amplifier, USER'S GUIDE* (2014); *Alienware Aurora R8, SETUP AND SPECIFICATIONS* (2018); *Inspiron 15 7000 Gaming, SERVICE MANUAL* (2017-2018); *XPS 13, SETUP AND SPECIFICATIONS* (2017); *Dell Latitude 5420/E5420/E5420m, OWNER'S MANUAL* (2011); *Alienware M17x R4, OWNER'S MANUAL* (2012).

companies and academic institutions. Dell is utilizing the technology claimed in the '529 patent without paying a reasonable royalty. Dell is infringing the '529 patent in a manner best described as willful, wanton, malicious, in bad faith, deliberate, consciously wrongful, flagrant, or characteristic of a pirate.

485. To the extent applicable, the requirements of 35 U.S.C. § 287(a) have been met with respect to the '529 patent.

486. As a result of Dell's infringement of the '529 patent, Dynamic Data has suffered monetary damages, and seeks recovery in an amount adequate to compensate for Dell's infringement, but in no event less than a reasonable royalty for the use made of the invention by Dell together with interest and costs as fixed by the Court.

COUNT XI
INFRINGEMENT OF U.S. PATENT NO. 7,519,230

487. Dynamic Data references and incorporates by reference the preceding paragraphs of this Complaint as if fully set forth herein.

488. Dell designs, makes, uses, sells, and/or offers for sale in the United States products and/or services for selecting a background motion vector for a pixel in an occlusion region of an image.

489. Dell designs, makes, sells, offers to sell, imports, and/or uses Dell products that contain VP9 encoding functionality, including but not limited to the following exemplary models: Chromebook 11, Chromebook 13 3380, Chromebook 5190 Education, Inspiron Chromebook 11 3181, Chromebook 11 3180, Chromebook 3120, Chromebook 7310, Inspiron Chromebook 11 3181 2-in-1, Chromebook 11 3189, Chromebook 5190 2-in-1, Inspiron Chromebook 7486, ChromeBox For Meetings, Dell Chromebox 3010, Inspiron Chromebook 7486, Inspiron

Chromebook 11 3181, and Inspiron Chromebook 11 3181 2-in-1 (collectively, the “Dell ‘230 Product(s)”).

490. The Dell ‘230 Products perform video processing compliant with the VP9 standard. The below documentation from Dell and Google states that the Dell ‘230 Products are compliant with the VP9 standard.

Power Options	65W AC adapter
Connectivity Options	Wireless 2x2 LAN Options: 802.11 ac/a/b/g/n + Bluetooth 4.0
Ports	1x USB 3.0 with BC1.2 charging / 1x USB 2.0 / HDMI 1.4
Slots & Chassis	SD/Multi Card Slot (push-Push type) / Kensington lock slot / Stereo headphone and microphone combo jack / 180 degree LCD hinge
Media	VP8/VP9 codec to support HD web streaming content up to 4K (with 4GB of memory)
Dimensions & Weight ¹	Width: 297.0mm, Depth: 217.7mm, Back Height: 21.0mm, Front Height: 20.1mm Width: 11.69", Depth: 8.57", Back Height: .83", Front Height: .79" Non-touch: 1245g (2.74lbs) / Touch: 1320g (2.91lbs)
Keyboard / Touchpad	Keyboard: Chrome OS layout with spill protection / Touchpad: 100mm x 56mm with spill protection
Durability	Mil-spec tested for drops, spills on the keyboard and track pad, vibration, heat, humidity, dust and dirt
Regulatory and Environmental Compliance	Pending Certification
Systems Management & Security ⁷	Dell KACE / Google Chrome Management Console [®]

DELL CHROMEBOOK 11 DATA SHEET at 2 (2015) (emphasis added) (“VP9/VP8 codec support HD web steaming content up to 4K”).

Ports	1x USB 3.0, 1x USB 2.0 / HDMI 1.4
Slots & Chassis	MicroSD / Noble lock slot / Stereo headphone and microphone combo jack
Media ⁵	VP8/VP9 codec to support HD web streaming content up to 4K (3840x2160 with 4GB+ of memory)
Dimensions & Weight ⁴	Width: 323.4mm, Depth: 225.8mm, Back Height: 16.7mm, Front Height: 12.8mm, Peak Height: 18.4mm (with rubber feet: Back Height: 21.2mm, Front Height: 19.4mm) Width: 12.93", Depth: 9.03", Back Height: 0.66", Front Height: 0.51" (with rubber feet: Back Height: 0.84", Front Height: 0.77") Non-touch: 1467.4g (3.23lbs) / Touch: 1616.4g (3.56lbs)
Keyboard / Touchpad	Backlit chiclet Keyboard: Chrome OS layout / Precision Touchpad, seamless glass integrated button: 105mm x 60mm
Regulatory and Environmental Compliance	Energy Star, EPEAT Gold
Systems Management & Security ⁸	Dell KACE / Google Chrome Management Console [®]

DELL CHROMEBOOK 13 DATA SHEET at 2 (2015) (emphasis added).

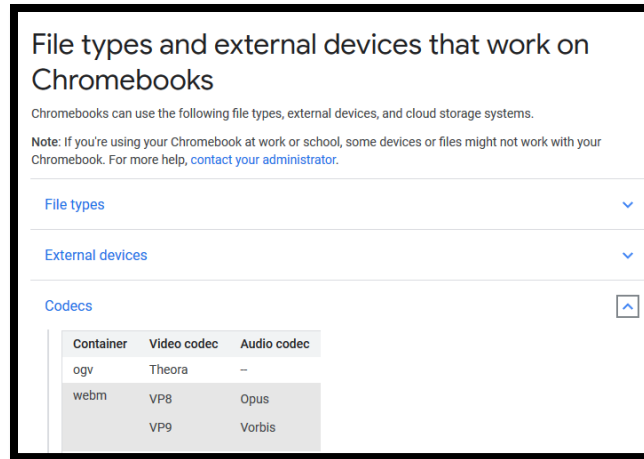

File Types And External Devices That Work On Chromebooks, GOOGLE SUPPORT WEBSITE, available at: <https://support.google.com/chromebook/answer/183093> (stating that Chromebooks can encode and decode to the VP9 standard).

491. On information and belief, one or more Dell subsidiaries and/or affiliates use the Dell ‘230 Products in regular business operations.

492. On information and belief, one or more of the Dell ‘230 Products include technology for selecting a background motion vector for a pixel in an occlusion region of an image.

493. On information and belief, one or more of the Dell ‘230 Products use a processor to compute a model-based motion vector for the pixel on the basis of a motion model being determined on the basis of a part of a motion vector field of an image.

494. On information and belief, one or more of the Dell ‘230 Products use a processor to compare the model-based motion vector with each of the motion vectors of the set of motion vectors.

495. On information and belief, one or more of the Dell ‘230 Products use a processor to select a particular motion vector of the set of motion vectors on the basis of the comparing and for assigning the particular motion vector as the background motion vector.

496. The Dell ‘230 Products enable the use of segmentation where it is used to “identify background and foreground areas in encoded video content.”

In the reference implementation, segmentation is currently used to identify background and foreground areas in encoded video content. The (static) background is then coded at a higher quality compared to the rest of the frame in certain reference frames (such as the alt-ref frame) that provides prediction that persists over a number of frames. In contrast, for the frames between these persistent reference frames, the background is given fewer bits by, for example, restricting the set of available reference buffers, using only the ZERO_MV coding mode, or skipping the residual coefficient block. The result is that more bits are available to code the foreground-portion of the scene, while still preserving very good perceptual quality on the static background. Other use cases involving spatial and temporal masking for perceptual quality improvement are conceivable.

A *VP9 Bitstream Overview*, NETWORK WORKING GROUP § 2.8 (February 18, 2013).

497. On information and belief, Dell has directly infringed and continues to directly infringe the ‘230 patent by, among other things, making, using, offering for sale, and/or selling technology for selecting a background motion vector for a pixel in an occlusion region of an image, including but not limited to the Dell ‘230 Products.

Coding Tools: Segmentation

- Segmentation feature significantly enhanced in VP9
 - Groups together blocks that share common characteristics into segments.
 - Indicate segmentation id at block level
 - Differentially encode segmentation map temporally
 - Encode control flags/features at segment level.
 - Q, loop filter strength, ref frame, skip mode
- Unlocking the true potential requires a smart encoder
 - Syntax provides a framework for encoding innovation
 - Various psychovisual optimizations possible

Static background

Moving foreground

Debargha Mukherjee, A TECHNICAL OVERVIEW OF VP9: THE LATEST ROYALTY FREE VIDEO CODEC FROM GOOGLE (2016)).

498. By making, using, testing, offering for sale, and/or selling products and services, including but not limited to the Dell ‘230 Products, Dell has injured Dynamic Data and is liable

for directly infringing one or more claims of the '230 patent, including at least claim 6, pursuant to 35 U.S.C. § 271(a).

499. On information and belief, one or more of the Dell '230 Products include technology for selecting a background motion vector for a pixel in an occlusion region of an image.

500. On information and belief, the Dell '230 Products are available to businesses and individuals throughout the United States.

501. On information and belief, the Dell '230 Products are provided to businesses and individuals located in the Southern District of New York.

502. On information and belief, Dell also indirectly infringes the '230 patent by actively inducing infringement under 35 U.S.C. § 271(b).

503. On information and belief, Dell has had knowledge of the '230 patent since at least service of the Original Complaint in this case or shortly thereafter, and on information and belief, Dell knew of the '230 patent and knew of its infringement, including by way of this lawsuit.

504. On information and belief, Dell intended to induce patent infringement by third-party customers and users of the Dell '230 Products and had knowledge that the inducing acts would cause infringement or was willfully blind to the possibility that its inducing acts would cause infringement. Dell specifically intended and was aware that the normal and customary use of the accused products would infringe the '230 patent. Dell performed the acts that constitute induced infringement, and would induce actual infringement, with knowledge of the '230 patent and with the knowledge that the induced acts would constitute infringement. For example, Dell provides the Dell '230 Products that have the capability of operating in a manner that infringe one or more of the claims of the '230 patent, including at least claim 6, and Dell further provides documentation and training materials that cause customers and end users of the Dell '230 Products

to utilize the products in a manner that directly infringe one or more claims of the ‘230 patent.²⁵⁹ By providing instruction and training to customers and end-users on how to use the Dell ‘230 Products in a manner that directly infringes one or more claims of the ‘230 patent, including at least claim 6, Dell specifically intended to induce infringement of the ‘230 patent. On information and belief, Dell engaged in such inducement to promote the sales of the Dell ‘230 Products, e.g., through Dell user manuals, product support, marketing materials, and training materials to actively induce the users of the accused products to infringe the ‘230 patent. Accordingly, Dell has induced and continues to induce users of the accused products to use the accused products in their ordinary and customary way to infringe the ‘230 patent, knowing that such use constitutes infringement of the ‘230 patent.

505. The ‘230 patent is well-known within the industry as demonstrated by multiple citations to the ‘230 patent in published patents and patent applications assigned to technology companies and academic institutions. Dell is utilizing the technology claimed in the ‘230 patent without paying a reasonable royalty. Dell is infringing the ‘230 patent in a manner best described as willful, wanton, malicious, in bad faith, deliberate, consciously wrongful, flagrant, or characteristic of a pirate.

506. To the extent applicable, the requirements of 35 U.S.C. § 287(a) have been met with respect to the ‘230 patent.

507. As a result of Dell’s infringement of the ‘230 patent, Dynamic Data has suffered monetary damages, and seeks recovery in an amount adequate to compensate for Dell’s infringement, but in no event less than a reasonable royalty for the use made of the invention by Dell together with interest and costs as fixed by the Court.

²⁵⁹ See, e.g., *Chromebook 13 3380*, QUICK START GUIDE (2017); *Dell Chromebox For Meetings 3010*, USER GUIDE (2014); *Inspiron 3181 2-in-1*, SETUP AND SPECIFICATIONS (2018).

COUNT XII
INFRINGEMENT OF U.S. PATENT NO. 7,542,041

508. Dynamic Data references and incorporates by reference the preceding paragraphs of this Complaint as if fully set forth herein.

509. Dell designs, makes, uses, sells, and/or offers for sale in the United States products and/or services for dynamically configuring a multi-pipe pipeline system.

510. Dell designs, makes, sells, offers to sell, imports, and/or uses Dell devices, including, Dell desktops, laptops, and all-in-one devices, including the following illustrative models: Dell G3 3579, Dell G3 3779, Dell G5 15 5587, XPS 15 9570, XPS 15 9575 2-in-1, XPS 15 9560, Inspiron 15 Gaming 7566, Inspiron 15 Gaming 7567, Inspiron 15 Gaming 7577, Inspiron 14 Gaming 7466, Inspiron 14 Gaming 7467, XPS 15 9550, Adamo 13, Adamo XPS, Alienware Alpha & Alienware Steam Machine, Alienware Alpha R2 & Alienware Steam Machine R2, Alienware Area 51, Alienware Area-51 ALX, Alienware Area-51 R2, Alienware Area-51 R4 and R5, Alienware Area-51 Threadripper Edition R3 and R6, Alienware Area-51 Threadripper Edition R7, Alienware Aurora, Alienware Aurora ALX, Alienware Aurora R2, Alienware Aurora R3, Alienware Aurora R4, Alienware Aurora R5, Alienware Aurora R6, Alienware Aurora R7, Alienware Aurora R8, Alienware X51, Alienware X51 R2, Alienware X51 R3, Alienware 15 R4, Alienware M17x, Alienware 17, Alienware M17x R2, Alienware 17 R2, Alienware M17x R3, Alienware 17 R3, Alienware M17x R4, Alienware 15, Alienware 17 R4, Alienware M18x, Alienware 15 R2, Alienware 17 R5, Alienware m15, Alienware M18x R2, Alienware 15 R3, Alienware 18, Alienware M15x, Dell G7 15 7588, XPS 13 9370, XPS 13 9360, and XPS 13 9365 2-in-1 (collectively, the “Dell ‘041 Product(s)”).

511. The Dell ‘041 Products contain discrete NVIDIA GPU processors (these are in addition to the integrated Intel graphic processing units).

1. On information and belief, one or more Dell subsidiaries and/or affiliates use the Dell ‘041 Products in regular business operations.
2. On information and belief, one or more of the Dell ‘041 Products include technology for dynamically configuring a multi-pipe pipeline system. Specifically, the Dell ‘041 Products comprise multiple vector pipelines that process data as it traverses the pipeline in the NVIDIA GPU.

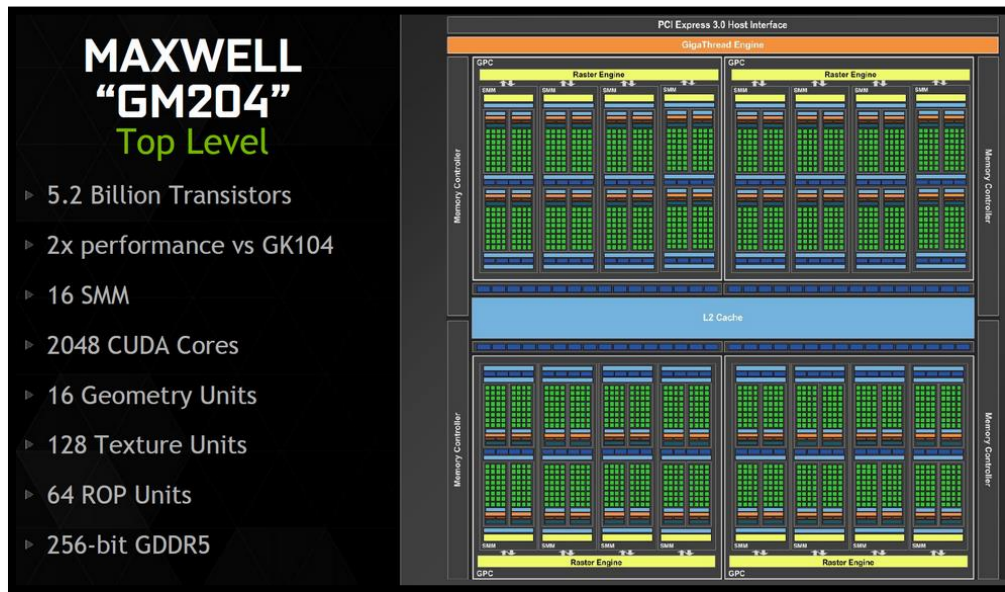

Chris Kubisch, *Life of a Triangle – NVIDIA’s Logical Pipeline*, NVIDIA DEVELOPER WEBSITE (March 16, 2015) (“The GPU is partitioned into multiple GPCs (Graphics Processing Cluster), each has multiple SMs (Streaming Multiprocessor) and one Raster Engine. There is lots of interconnects in this process, most notably a Crossbar that allows work migration across GPCs or other functional units like ROP (render output unit) subsystems.”).

3. On information and belief, Dell has directly infringed and continues to directly infringe the ‘041 patent by, among other things, making, using, offering for sale, and/or selling technology for dynamically configuring a multi-pipe pipeline system, including but not limited to the Dell ‘041 Products.
4. The Dell ‘041 Products are synchronized and process data (in the NVIDIA discrete GPU) in order such that correct triangle order is maintained.

Thread Level Preemption for compute operates similarly to Pixel Level Preemption for graphics. Compute workloads are composed of multiple grids of thread blocks, each grid containing many threads. When a preemption request is received, the threads that are currently running on the SMs are completed. Other units save their current position to be ready to pick up where they left off later, and then the GPU is ready to switch tasks. The entire process of switching tasks can complete in less than 100 μ s after the currently running threads finish.

NVIDIA GeForce GTX 1080, NVIDIA WHITEPAPER at 16 (2016).

5. On information and belief, one or more of the Dell ‘041 Products enable a multiple-pipeline system that is dynamically configurable to effect various combinations of functions for each pipeline.

6. The Dell ‘041 Products comprise a plurality of pipelines. Each pipeline contains multiple core pipeline elements that are configured to process data as it flows through the pipeline. The below excerpt from NVIDIA reference documentation describes that product uses multiple compute pipelines that sequentially process data.

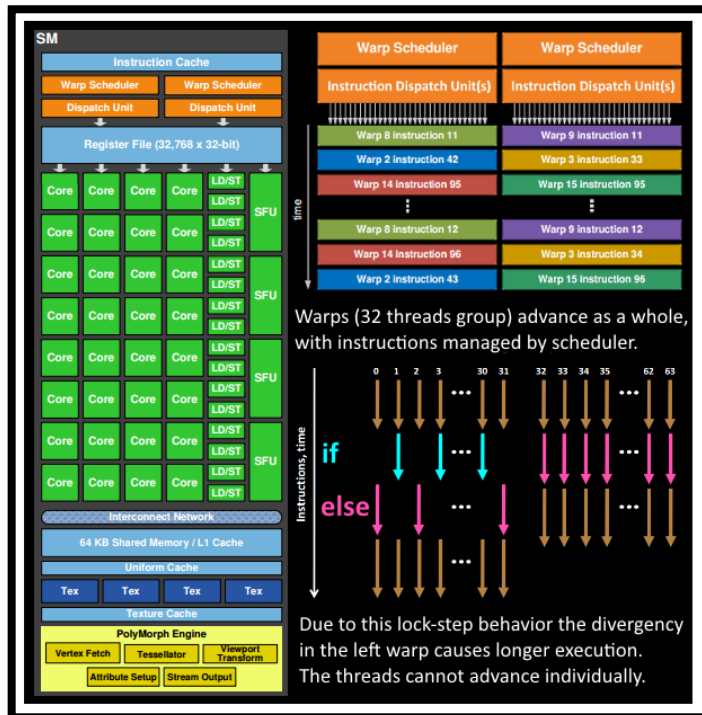

Chris Kubisch, *Life of a Triangle – NVIDIA’s Logical Pipeline*, NVIDIA DEVELOPER WEBSITE (March 16, 2015) (“The GPU is partitioned into multiple GPCs (Graphics Processing Cluster), each has multiple SMs (Streaming Multiprocessor) and one Raster Engine. There is lots of

interconnects in this process, most notably a **Crossbar** that allows work migration across GPCs or other functional units like ROP (render output unit) subsystems.”).

7. The Dell ‘041 Products contain a “Scheduler” that enables to data to be processed in a subsequent manner as it traverses the pipeline. The below excerpt from NVIDIA documentation (that is directly applicable to the Dell ‘041 Products which contain the NVIDIA GPUs) shows the scheduler.

To ensure that rendering results are predictable, the DX API has always specified “in order” processing rules for the raster pipeline, in particular the Color and Z units (“ROP”). Given two triangles sent to the GPU in order—first triangle “A,” then “B”—that touch the same XY screen location, the GPU hardware guarantees that triangle “A” will blend its color result before “B” blends it. Special interlock hardware in the ROP is responsible for enforcing this ordering requirement

NVIDIA GeForce GTX 980 Whitepaper, NVIDIA MAXWELL DOCUMENTATION at 24 (2014).

8. On information and belief, one or more of the Dell ‘041 Products include a multiple pipeline system that includes a pool of auxiliary function blocks that are provided as required to select pipelines.

9. On information and belief, one or more of the Dell ‘041 Products consist of a multiple-pipeline system wherein each pipeline is configured to include a homogenous set of core functions.

10. On information and belief, one or more of the Dell ‘041 Products include a pool of auxiliary functions is provided for selective insertion of auxiliary functions between core functions of select pipelines.

11. The Dell ‘041 Products comprise a plurality of pipelines for processing data. These pipelines are coupled to a plurality of auxiliary elements that control the function of the pipelines. Specifically, axillary elements can pass signals to multiple pipelines using crossbar fabrics.

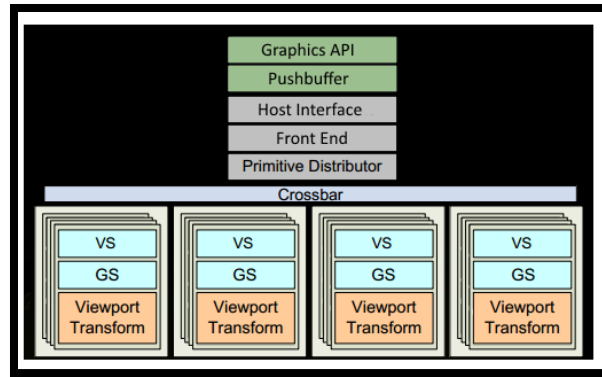

Chris Kubisch, *Life of a Triangle – NVIDIA’s Logical Pipeline*, NVIDIA DEVELOPER WEBSITE (March 16, 2015) (“Now it gets exciting, our triangle is about to be chopped up and potentially leaving the GPC it currently lives on. The bounding box of the triangle is used to decide which raster engines need to work on it, as each engine covers multiple tiles of the screen. It sends out the triangle to one or multiple GPCs via the Work Distribution Crossbar. We effectively split our triangle into lots of smaller jobs now.”).

12. On information and belief, one or more of the Dell ‘041 Products includes auxiliary functions wherein each auxiliary function includes a multiplexer that allows it to be selectively coupled within each pipeline.

13. On information and belief, one or more of the Dell ‘041 Products contain a processing system that includes a plurality of pipelines, with each pipeline of the plurality including a plurality of core pipeline elements that are configured to sequentially process data as it traverses the pipeline.

14. On information and belief, one or more of the Dell ‘041 Products contain a processing system that includes a plurality of auxiliary elements, each auxiliary element of the plurality of auxiliary elements being configured to be selectively coupled to multiple pipelines of the plurality of pipelines.

15. On information and belief, one or more of the Dell ‘041 Products contain a processing system wherein the auxiliary elements are responsive to external coupling-select signals.

16. On information and belief, one or more of the Dell '041 Products contain a processing system wherein a plurality of auxiliary elements are within a selected pipeline of the multiple pipelines, between a pair of core pipeline elements of the plurality of core pipeline elements to process the data as it traverses between the pair of core elements.

512. On information and belief, the Dell '041 Products are available to businesses and individuals throughout the United States.

513. On information and belief, the Dell '041 Products are provided to businesses and individuals located in the Southern District of New York.

514. By making, using, testing, offering for sale, and/or selling products and services for dynamically configuring a multi-pipe pipeline system, including but not limited to the Dell '041 Products, Dell has injured Dynamic Data and is liable to the Plaintiff for directly infringing one or more claims of the '041 patent, including at least claim 1 pursuant to 35 U.S.C. § 271(a).

515. On information and belief, Dell also indirectly infringes the '041 patent by actively inducing infringement under 35 U.S.C. § 271(b).

516. Dell has had knowledge of the '041 patent since at least service of the Original Complaint in this case or shortly thereafter, and on information and belief, Dell knew of the '041 patent and knew of its infringement, including by way of this lawsuit.

517. On information and belief, Dell intended to induce patent infringement by third-party customers and users of the Dell '041 Products and had knowledge that the inducing acts would cause infringement or was willfully blind to the possibility that its inducing acts would cause infringement. Dell specifically intended and was aware that the normal and customary use of the accused products would infringe the '041 patent. Dell performed the acts that constitute induced infringement, and would induce actual infringement, with knowledge of the '041 patent

and with the knowledge that the induced acts would constitute infringement. For example, Dell provides the Dell '041 Products that have the capability of operating in a manner that infringe one or more of the claims of the '041 patent, including at least claim 1, and Dell further provides documentation and training materials that cause customers and end users of the Dell '041 Products to utilize the products in a manner that directly infringe one or more claims of the '041 patent.²⁶⁰ By providing instruction and training to customers and end-users on how to use the Dell '041 Products in a manner that directly infringes one or more claims of the '041 patent, including at least claim 1, Dell specifically intended to induce infringement of the '041 patent. On information and belief, Dell engaged in such inducement to promote the sales of the Dell '041 Products, e.g., through Dell user manuals, product support, marketing materials, and training materials to actively induce the users of the accused products to infringe the '041 patent. Accordingly, Dell has induced and continues to induce users of the accused products to use the accused products in their ordinary and customary way to infringe the '041 patent, knowing that such use constitutes infringement of the '041 patent.

518. The '041 patent is well-known within the industry as demonstrated by multiple citations to the '041 patent in published patents and patent applications assigned to technology companies and academic institutions. Dell is utilizing the technology claimed in the '041 patent without paying a reasonable royalty. Dell is infringing the '041 patent in a manner best described as willful, wanton, malicious, in bad faith, deliberate, consciously wrongful, flagrant, or characteristic of a pirate.

²⁶⁰ See, e.g., *Dell G7 I5*, SETUP AND SPECIFICATIONS (2018); *Alienware Graphics Amplifier*, USER'S GUIDE (2014); *Alienware Alpha R2*, SETUP AND SPECIFICATIONS (2016); *Alienware Aurora R8*, SETUP AND SPECIFICATIONS (2018); *Inspiron 15 7000 Gaming*, SERVICE MANUAL (2017-2018); *XPS I3*, SETUP AND SPECIFICATIONS (2017); *Alienware M17x R4*, OWNER'S MANUAL (2012).

519. To the extent applicable, the requirements of 35 U.S.C. § 287(a) have been met with respect to the '041 patent.

520. As a result of Dell's infringement of the '041 patent, Dynamic Data has suffered monetary damages, and seeks recovery in an amount adequate to compensate for Dell's infringement, but in no event less than a reasonable royalty for the use made of the invention by Dell together with interest and costs as fixed by the Court.

COUNT XIII
INFRINGEMENT OF U.S. PATENT NO. 7,571,450

521. Dynamic Data references and incorporates by reference the preceding paragraphs of this Complaint as if fully set forth herein.

522. Dell designs, makes, uses, sells, and/or offers for sale in the United States products and/or services for displaying information.

523. Dell designs, makes, sells, offers to sell, imports, and/or uses Dell devices that contain H.265 decoding functionality, including but not limited to Dell desktops, laptops, projectors, and all-in-one devices, including the following exemplary models: Dell G3 3579, Dell G3 3779, Dell G5 15 5587, Dell G7 15 7588, Inspiron 14 Gaming 7466, Inspiron 14 Gaming 7467, Inspiron 15 Gaming 7566, Inspiron 15 Gaming 7567, Inspiron 15 Gaming 7577, Inspiron 5457, Inspiron 5458, Inspiron 5557, Inspiron 5558, Inspiron 5587, Inspiron 5758, Inspiron 7447, Inspiron 7460, Inspiron 7466, Inspiron 7472, Inspiron 7557, Inspiron 7559, Inspiron 7560, Inspiron 7566, Inspiron 7572, Inspiron 7588, Inspiron Desktop 3470, Inspiron Desktop 3670, Inspiron Desktop 5676, Inspiron Desktop 5680, Latitude 3190, Latitude 3190 2-in-1, Latitude 5420, Latitude 5424, Latitude 5491, Latitude 5591, Latitude 7424, Optiplex 3060, Optiplex 5060, Optiplex 5260 AIO, Optiplex 7060, Optiplex 7460 AIO, Optiplex 7760 AIO, Optiplex XE3,

Precision 3430, Precision 3430 XL Tower, Precision 3530, Precision 3630, Precision 3630 XL Tower, Precision 3930 Rack, Precision 3930 XL RACK, Precision 5510, Precision 5520, Precision 5530, Precision 7530, Precision 7730, Precision M3800, Vostro Desktop 3470, Vostro Desktop 3670, Vostro Notebook 3458, Vostro Notebook 3558, Vostro Notebook 5459, Vostro Notebook 5468, Vostro Notebook 5480, Vostro Notebook 5568, Vostro Notebook 7580, XPS 13 9360, XPS 13 9365 2-in-1, XPS 13 9370, XPS 15 9550, XPS 15 9560, XPS 15 9570, XPS 15 9575 2-in-1, XPS Desktop XPS 8930, XPS Notebook 9365, XPS Notebook 9530, XPS Notebook 9550, XPS Notebook 9560, XPS Notebook 9570, Dell Advanced Projector S718QL, Alienware 15, Alienware 15 R2-R4, Alienware 17, Alienware 17 R2-R5, Alienware 18, Alienware Area 51, Alienware Area-51 ALX, Alienware Area-51 R2-R5 & R7, Alienware Area-51 Threadripper Edition R3 & R6 & R7, Alienware Aurora, Alienware Aurora ALX, Alienware Aurora R2-R8, Alienware m15, Alienware M15x, Alienware M17x, Alienware M17x R2-R4, Alienware M18x, Alienware M18x R2, Alienware X51, and Alienware X51 R2 & R3 (collectively, the “Dell ‘450 Product(s)”).

524. The Dell ‘450 Products perform video processing compliant with the HEVC standard. *See e.g., Dell Desktop Support, DELL SUPPORT WEBSITE, available at: <https://www.dell.com/support/home/us/en/19/products/desktop>; Dell Laptop Support, DELL SUPPORT WEBSITE, available at: <https://www.dell.com/support/home/us/en/19/products/laptop>*

525. The below table shows Dell ‘450 Products that contain the infringing HEVC compliant video processing technology.

Exemplar Dell Models	Graphics Processing Unit (GPU)	HEVC Decode/Encode ²⁶¹
Dell G3 3579	NVIDIA GeForce GTX 1050 Ti ²⁶²	Yes
Dell G3 3779	NVIDIA GeForce GTX 1060 w/ Max Q ²⁶³	Yes
Dell G5 15 5587	NVIDIA GeForce GTX 1060 w/ Max Q ²⁶⁴	Yes
Dell G7 15 7588	NVIDIA GeForce GTX 1060 w/ Max Q ²⁶⁵	Yes
Inspiron 14 Gaming 7466	Intel HD Graphics 530 ²⁶⁶	Yes
Inspiron 14 Gaming 7467	Intel HD Graphics 630 ²⁶⁷	Yes
Inspiron 15 Gaming 7566	Intel HD Graphics 530 (Integrated) / NVIDIA GeForce GTX630M (Discrete) ²⁶⁸	Yes
Inspiron 15 Gaming 7567	NVIDIA GeForce GTX 1050Ti with 4GB GDDR5 / NVIDIA GeForce GTX 1050 with 4GB GDDR5 ²⁶⁹	Yes
Inspiron 15 Gaming 7577	Intel HD Graphics 630 (Integrated) / NVIDIA GeForce GTX 1050/ GTX 1050 Ti/ GTX 1060 Max-Q (Discrete) ²⁷⁰	Yes
Inspiron 5457	Intel HD Graphics 520 (integrated) / NVIDIA GeForce 930M (Discrete) ²⁷¹	Yes
Inspiron 5458	Intel HD Graphics 4400/4500 (integrated) / NVIDIA GeForce 920M (discrete) ²⁷²	Yes
Inspiron 5557	Intel HD Graphics 520 (integrated) / NVIDIA GeForce 930M (discrete) ²⁷³	Yes

²⁶¹ *NVIDIA Video Encode And Decode GPU Support Matrix*, NVIDIA DEVELOPER WEBSITE, available at: <https://developer.nvidia.com/video-encode-decode-gpu-support-matrix> (showing support for HEVC in NVIDIA Graphics cards); *Intel Product Matrix*, INTEL WEBSITE, available at: <https://www.intel.com/content/www/us/en/products> (showing HEVC Support); *Intel Graphics Product Specifications*, INTEL WEBSITE, available at: <https://www.intel.com/content/www/us/en/architecture-and-technology/visual-technology/graphics-overview.html>.

²⁶² *Dell Model G3 3579*, DELL WEBSITE, available at: <https://www.dell.com/en-us/work/shop/dell-laptops-and-notebooks/dell-g3-15-gaming-laptop/spd/g-series-15-3579-laptop>

²⁶³ *Dell Model G3 3779*, DELL WEBSITE, available at: <https://www.dell.com/en-us/shop/dell-laptops/dell-g3-17-gaming/spd/g-series-17-3779-laptop>

²⁶⁴ *Dell Model G5 15 5587*, DELL WEBSITE, available at: <https://www.dell.com/en-us/shop/dell-laptops/dell-g5-15-gaming/spd/g-series-15-5587-laptop>

²⁶⁵ *Dell Model G7 15 7588*, DELL WEBSITE, available at: <https://www.dell.com/en-us/shop/dell-laptops/dell-g7-15-gaming/spd/g-series-15-7588-laptop>

²⁶⁶ *Dell Inspiron 14 Gaming Setup and Specifications*, DELL MANUAL MODEL NO. INSPIRON 14-7466 at 18 (2016).

²⁶⁷ *Dell Inspiron 14 7000 Gaming Series Setup and Specifications*, DELL SPECIFICATIONS MODEL NO. INSPIRON 14-7467 at 18 (2016)

²⁶⁸ *Dell Inspiron 15 Gaming Setup and Specifications*, DELL MANUAL MODEL NO. 15-7566 at 18 (2016)

²⁶⁹ *Dell Inspiron Model 7567*, DELL WEBSITE, available at: <https://www.dell.com/us/dfh/p/inspiron-15-7567-laptop/pd>

²⁷⁰ *Dell Inspiron 15 7000 Gaming Setup and Specifications*, DELL MANUAL MODEL NO. INSPIRON 15-7577 at 23 (2018).

²⁷¹ *Dell Inspiron 14 5000 Series Specification*, DELL SPECIFICATIONS MODEL NO. INSPIRON 14-5457 at 12 (2015).

²⁷² *Dell Inspiron 14 5000 Series Specification*, DELL SPECIFICATIONS MODEL NO. INSPIRON 14-5458 at 12 (2015).

²⁷³ *Dell Inspiron 14 5000 Series Specification*, DELL SPECIFICATIONS MODEL NO. INSPIRON 14-5557 at 12 (2015).

Inspiron 5558	Intel HD Graphics 4400/4500 (integrated) / NVIDIA GeForce 920M (discrete) ²⁷⁴	Yes
Inspiron 5587	NVIDIA GeForce GTX 1060 Max-Q ²⁷⁵	Yes
Inspiron 5758	Intel HD Graphics 4400/4500 (integrated) / NVIDIA GeForce 920M (discrete) ²⁷⁶	Yes
Inspiron 7447	Intel Iris Pro Graphic 5200 (integrated) / NVIDIA GeForce GTX 850M (discrete) ²⁷⁷	Yes
Inspiron 7460	Intel HD Graphics 610/620/635 (integrated)/ NVIDIA GeForce 940M ²⁷⁸	Yes
Inspiron 7466	Intel HD Graphics 530 (integrated) / NVIDIA GeForce GTX 950M ²⁷⁹	Yes
Alienware Area 51	NVIDIA GeForce RTX 2080 Ti OC with 11GB GDDR6 ²⁸⁰	Yes
Alienware Area-51 R2	NVIDIA® GeForce GTX ²⁸¹	Yes
Alienware Area-51 R4/R5	NVIDIA® GeForce GTX ²⁸²	Yes
Alienware Area-51 Threadripper R3/R6	NVIDIA GeForce GTX 1080 ²⁸³	Yes
Alienware Area-51 Threadripper Edition R7	Dual NVIDIA® GeForce® RTX 2080 Ti OC ²⁸⁴	Yes
Alienware Aurora	NVIDIA® GeForce® RTX 2080 Ti OC with 11GB GDDR6 ²⁸⁵	Yes

526. Dell documentation states that the Dell ‘450 Products are compliant with the HEVC standard as shown in the following excerpts.

²⁷⁴ *Dell Inspiron 14 5000 Series Specification*, DELL SPECIFICATIONS MODEL NO. INSPIRON 14-5558 at 12 (2015).

²⁷⁵ *Dell Inspiron Model 5587*, DELL WEBSITE, available at: <https://www.dell.com/en-us/shop/dell-laptops/dell-g5-15-gaming/spd/g-series-15-5587-laptop>

²⁷⁶ *Dell Inspiron 17 5000 Series Specification*, DELL SPECIFICATIONS MODEL NO. INSPIRON 17-5758 at 12 (2015).

²⁷⁷ *Dell Inspiron 14 7000 Series Specification*, DELL SPECIFICATIONS MODEL NO. INSPIRON 7447 at 12 (2014).

²⁷⁸ *Dell Inspiron 14 7000 Setup and Specification*, DELL MANUAL MODEL NO. INSPIRON 14-7460 at 18 (2018)

²⁷⁹ *Dell Inspiron 14 Gaming Setup and Specifications*, DELL MANUAL MODEL NO. INSPIRON 14-7466 at 18 (2016).

²⁸⁰ *Dell Alienware Specifications*, DELL WEBSITE, available at: <https://www.dell.com/en-us/shop/dell-desktop-computers/alienware-area-51/spd/alienware-area51-r5>

²⁸¹ *Dell Alienware Specifications*, DELL WEBSITE, available at: <https://www.dell.com/en-us/shop/cty/pdp/spd/alienware-area51-r2>

²⁸² *Dell Alienware Specifications*, DELL WEBSITE, available at: <https://www.dell.com/en-us/shop/dell-desktop-computers/alienware-area-51-gaming-desktop/spd/alienware-area51-r4>

²⁸³ *Dell Alienware Specifications*, DELL WEBSITE, available at: <https://www.dell.com/en-us/shop/dell-desktop-computers/alienware-area-51-threadripper-edition/spd/alienware-area51-r6>

²⁸⁴ *Dell Alienware Specifications*, DELL WEBSITE, available at: <https://www.dell.com/en-us/shop/desktops/area-51-threadripper/spd/alienware-area51-r7>

²⁸⁵ *Dell Alienware Specifications*, DELL WEBSITE, available at: <https://www.dell.com/en-us/shop/dell-desktop-computers/alienware-aurora/spd/alienware-aurora-r7-desktop>

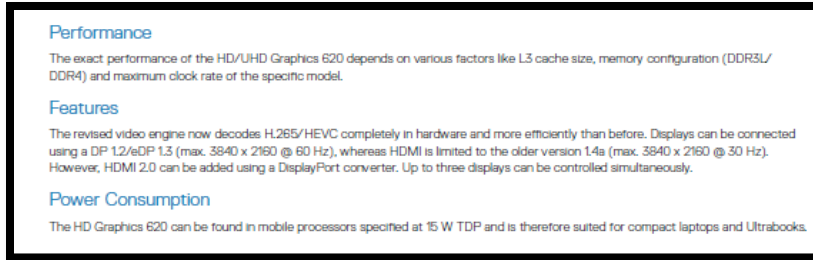

DELL LATITUDE 5420 RUGGED OWNER’S MANUAL at 44 (2015) (“The revised video engine now decodes H.265/HEVC completely in hardware and more efficiently than before.”).

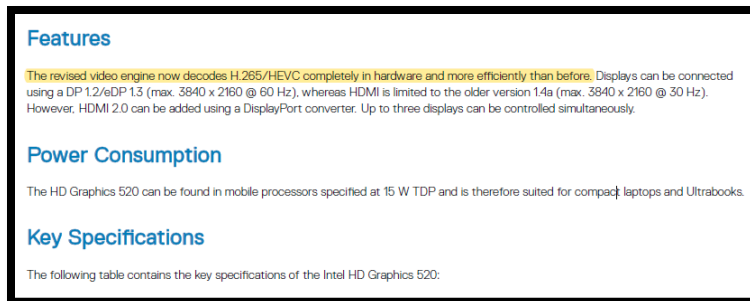

DELL VOSTRO 14-3468 OWNER’S MANUAL at 55 (2018) (annotation added) (“The revised video engine now decodes H.265/HEVC completely in hardware and more efficiently than before.”).



DELL PRODUCT QUICK REFERENCE MATRIX Q4 2018 at 17 (2018) (“New HEVC 10-bit and VP9 decode”).

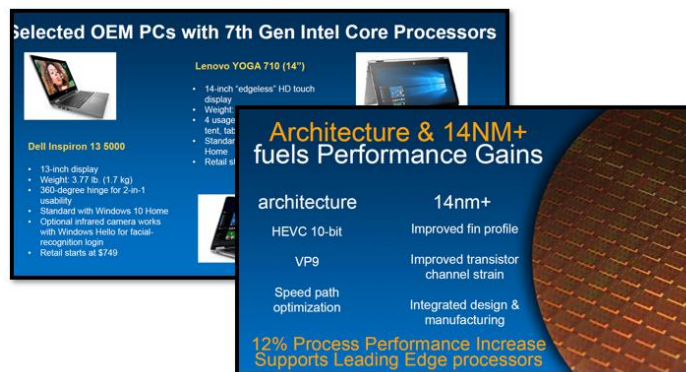

David Bradshaw, 7th Generation Intel Core Processor, INTEL PRESENTATION at 3 & 12 (2016).

527. On information and belief, by complying with the HEVC standard, the Dell devices – such as the Dell ‘450 Products – necessarily infringe the ‘450 patent. Mandatory sections of the HEVC standard require the elements required by certain claims of the ‘450 patent, including but not limited to claim 8. *High Efficiency Video Coding, SERIES H: AUDIOVISUAL AND Multimedia SYSTEMS: INFRASTRUCTURE OF AUDIOVISUAL SERVICES – CODING OF MOVING VIDEO REC. ITU-T H.265* (February 2018). The following sections of the HEVC Standard are relevant to Dell’s infringement of the ‘450 patent: “5.3 Logical operators;” “5.10 Variables, syntax elements and tables;” “5.11 Text description of logical operations;” “7.2 Specification of syntax functions and descriptors;” “7.3.1 NAL unit syntax;” “7.3.2 Raw byte sequence payloads, trailing bits and byte alignment syntax;” “7.3.5 Supplemental enhancement information message syntax;” “7.4.2 NAL unit semantics;” and “7.4.6 Supplemental enhancement information message semantics.”

528. On information and belief, the Dell ‘450 Products receive data that is segmented into Network Abstraction Layer (“NAL”) Units. NAL Units are segments of data that can include video data and overlay data (such as captions and overlay images). The Dell ‘450 Products support the receipt of VCL and non-VCL NAL units. The VCL NAL units contain the data that represents the values of the samples in the video pictures, and the non-VCL NAL units contain any associated additional information such as parameter sets or overlay data.

HEVC uses a NAL unit based bitstream structure. A coded bitstream is partitioned into NAL units which, when conveyed over lossy packet networks, should be smaller than the maximum transfer unit (MTU) size. Each NAL unit consists of a NAL unit header followed by the NAL unit payload. There are two conceptual classes of NAL units. Video coding layer (VCL) NAL units containing coded sample data, e.g., coded slice NAL units, whereas non-VCL NAL units that contain metadata typically belonging to more than one coded picture, or where the association with a single coded picture would be meaningless, such as parameter set NAL units, or where the information is not needed by the decoding process, such as SEI NAL units.

Rickard Sjöberg et al, *Overview of HEVC High-Level Syntax and Reference Picture Management*, IEEE TRANSACTIONS ON CIRCUITS AND SYSTEMS FOR VIDEO TECHNOLOGY, Vol. 22, No. 12 at 1859 (December 2012) (emphasis added).

529. The Dell ‘450 Products process data in the form of VCL NAL Units that contain segments of data which are used to generate an image (e.g., HEVC image) on a display device. Each VCL NAL Unit comprises a discrete number of bites which make up a segment. The following excerpt from the HEVC specification describes a NAL unit as being a segment with a “demarcation” setting forth where the segment ends and begins.

NumBytesInNalUnit specifies the size of the NAL unit in bytes. This value is required for decoding of the NAL unit. Some form of demarcation of NAL unit boundaries is necessary to enable inference of NumBytesInNalUnit. One such demarcation method is specified in Annex B for the byte stream format. Other methods of demarcation may be specified outside of this Specification.

High Efficiency Video Coding, SERIES H: AUDIOVISUAL AND MULTIMEDIA SYSTEMS: INFRASTRUCTURE OF AUDIOVISUAL SERVICES – CODING OF MOVING VIDEO REC. ITU-T H.265 at § 7.4.2.1 (February 2018) (emphasis added).

530. The Dell ‘450 Products receive VCL NAL units that contain the data that represents the values of the samples in the video pictures, and non-VCL NAL units that contain associated additional information such as parameter sets or overlay data.

HEVC uses a NAL unit based bitstream structure. A coded bitstream is partitioned into NAL units which, when conveyed over lossy packet networks, should be smaller than the maximum transfer unit (MTU) size. Each NAL unit consists of a NAL unit header followed by the NAL unit payload. There are two conceptual classes of NAL units. Video coding layer (VCL) NAL units containing coded sample data, e.g., coded slice NAL units, whereas non-VCL NAL units that contain metadata typically belonging to more than one coded picture, or where the association with a single coded picture would be meaningless, such as parameter set NAL units, or where the information is not needed by the decoding process, such as SEI NAL units.

Rickard Sjöberg et al, *Overview of HEVC High-Level Syntax and Reference Picture Management*, IEEE TRANSACTIONS ON CIRCUITS AND SYSTEMS FOR VIDEO TECHNOLOGY, Vol. 22, No. 12 at 1859 (December 2012) (emphasis added).

531. The Dell ‘450 Products perform filtering, wherein the filtering enables a user to select a data element based on the user’s selection. Specifically, a user can select the display of Non-VCL NAL Unit data which can include closed captions or other overlay information that is selected based on the user interaction. The data that is selected by the user is parsed by the system and filtered. The Non-VCL NAL Units include supplemental enhancement information (“SEI”)

messages. The SEI data that is received contains overlay information that can be combined with the image data that has already been received.

	Descriptor
sei_message() {	
payloadType = 0	
while(next_bits(8) == 0xFF) {	
ff_byte /* equal to 0xFF */	f(8)
payloadType += 255	
}	
last_payload_type_byte	u(8)
payloadType += last_payload_type_byte	
payloadSize = 0	
while(next_bits(8) == 0xFF) {	
ff_byte /* equal to 0xFF */	f(8)
payloadSize += 255	
}	
last_payload_size_byte	u(8)
payloadSize += last_payload_size_byte	
sei_payload(payloadType, payloadSize)	
}	

High Efficiency Video Coding, SERIES H: AUDIOVISUAL AND MULTIMEDIA SYSTEMS: INFRASTRUCTURE OF AUDIOVISUAL SERVICES – CODING OF MOVING VIDEO REC. ITU-T H.265 at § 7.3.5 (February 2018).

532. The Dell ‘450 Products perform rendering of an output image to be displayed on a display device on the basis of the first data-element selected by the filter. The overlay data is used to render overlays of the display data. The amount of overlay data that is downloaded in the form of Non-VCL data comprises a portion of the overlay that is displayed.

533. On information and belief, Dell has directly infringed and continues to directly infringe the ‘450 Patent by, among other things, making, using, offering for sale, and/or selling technology for displaying information, including but not limited to the Dell ‘450 Products.

534. On information and belief, one or more of the Dell ‘450 Products enable methods and systems wherein a user does not need to make a new selection after being switched from one service to a second service.

535. On information and belief, one or more of the Dell '450 Products perform a method of displaying information on a display device wherein receiving a transport stream comprises services, with the services having elementary streams of video and of data elements.

536. On information and belief, one or more of the Dell '450 Products perform a method of displaying information on a display device wherein user actions of making a user selection of a type of information to be displayed on the device are received.

537. On information and belief, one or more of the Dell '450 Products perform a method of displaying information on a display device wherein filtering to select a data element of a first one of the services on the basis of the user selection is performed.

538. On information and belief, one or more of the Dell '450 Products perform a method of displaying information on a display device wherein rendering to calculate an output image to be displayed on the display device, on the basis of the first data element selected by the filer is performed.

539. On information and belief, one or more of the Dell '450 Products perform a method of displaying information on a display device wherein switching from the first one of the services to a second one of the services, characterized in comprising a second step of filtering to select a second data-element of the second one of the services, on the basis of the user selection is performed.

540. On information and belief, one or more of the Dell '450 Products perform a method of displaying information on a display device wherein being switched from the first one of the services to the second one of the services, with the data-element and the second data-element being mutually semantically related and a second step of rendering to calculate the output image to be

displayed on the display device, on the basis of the second data-element selected by the filter is performed.

541. On information and belief, the Dell '450 Products are available to businesses and individuals throughout the United States.

542. On information and belief, the Dell '450 Products are provided to businesses and individuals located in the Southern District of New York.

543. By making, using, testing, offering for sale, and/or selling products and services for displaying information, including but not limited to the Dell '450 Products, Dell has injured Dynamic Data and is liable to the Plaintiff for directly infringing one or more claims of the '450 patent, including at least claim 8 pursuant to 35 U.S.C. § 271(a).

544. On information and belief, Dell also indirectly infringes the '450 patent by actively inducing infringement under 35 U.S.C. § 271(b).

545. Dell has had knowledge of the '450 patent since at least service of the Original Complaint in this case or shortly thereafter, and on information and belief, Dell knew of the '450 patent and knew of its infringement, including by way of this lawsuit.

546. On information and belief, Dell intended to induce patent infringement by third-party customers and users of the Dell '450 Products and had knowledge that the inducing acts would cause infringement or was willfully blind to the possibility that its inducing acts would cause infringement. Dell specifically intended and was aware that the normal and customary use of the accused products would infringe the '450 patent. Dell performed the acts that constitute induced infringement, and would induce actual infringement, with knowledge of the '450 patent and with the knowledge that the induced acts would constitute infringement. For example, Dell provides the Dell '450 Products that have the capability of operating in a manner that infringe one

or more of the claims of the ‘450 patent, including at least claim 8, and Dell further provides documentation and training materials that cause customers and end users of the Dell ‘450 Products to utilize the products in a manner that directly infringe one or more claims of the ‘450 patent.²⁸⁶ By providing instruction and training to customers and end-users on how to use the Dell ‘450 Products in a manner that directly infringes one or more claims of the ‘450 patent, including at least claim 8, Dell specifically intended to induce infringement of the ‘450 patent. On information and belief, Dell engaged in such inducement to promote the sales of the Dell ‘450 Products, e.g., through Dell user manuals, product support, marketing materials, and training materials to actively induce the users of the accused products to infringe the ‘450 patent. Accordingly, Dell has induced and continues to induce users of the accused products to use the accused products in their ordinary and customary way to infringe the ‘450 patent, knowing that such use constitutes infringement of the ‘450 patent.

547. The ‘450 patent is well-known within the industry as demonstrated by multiple citations to the ‘450 patent in published patents and patent applications assigned to technology companies and academic institutions. Dell is utilizing the technology claimed in the ‘450 patent without paying a reasonable royalty. Dell is infringing the ‘450 patent in a manner best described as willful, wanton, malicious, in bad faith, deliberate, consciously wrongful, flagrant, or characteristic of a pirate.

²⁸⁶ See, e.g., *Alienware Graphics Amplifier*, USER’S GUIDE (2014); *Alienware Alpha R2*, SETUP AND SPECIFICATIONS (2016); *Inspiron 15 7000 Gaming*, SERVICE MANUAL (2017-2018); *Dell Vostro 15-3558*, OWNER’S MANUAL (2015); *XPS 15*, SERVICE MANUAL (2018); *Dell Optiplex 5060 Micro*, SETUP AND SPECIFICATIONS GUIDE (2018); *Dell Latitude E7470*, OWNER’S MANUAL (2016); *Dell G7 15*, SETUP AND SPECIFICATIONS (2018); *XPS 13*, SETUP AND SPECIFICATIONS (2017); *Dell Precision Mobile Workstation M4800*, OWNER’S MANUAL (2015); *Dell Precision Tower 5810*, OWNER’S MANUAL (2017); *Dell Canvas 27*, USER’S GUIDE (2017).

548. To the extent applicable, the requirements of 35 U.S.C. § 287(a) have been met with respect to the '450 patent.

549. As a result of Dell's infringement of the '450 patent, Dynamic Data has suffered monetary damages, and seeks recovery in an amount adequate to compensate for Dell's infringement, but in no event less than a reasonable royalty for the use made of the invention by Dell together with interest and costs as fixed by the Court.

COUNT XIV
INFRINGEMENT OF U.S. PATENT NO. 7,750,979

550. Dynamic Data references and incorporates by reference the preceding paragraphs of this Complaint as if fully set forth herein.

551. Dell designs, makes, uses, sells, and/or offers for sale in the United States products and/or services for motion compensation in video signal processing.

552. Dell designs, makes, sells, offers to sell, imports, and/or uses Dell desktops, laptops, and all-in-one devices, including but not limited to the following exemplary models: Dell G3 3579, Dell G3 3779, Dell G5 15 5587, XPS 15 9570, XPS 15 9575 2-in-1, XPS 15 9560, Inspiron 15 Gaming 7566, Inspiron 15 Gaming 7567, Inspiron 15 Gaming 7577, Inspiron 14 Gaming 7466, Inspiron 14 Gaming 7467, XPS 15 9550, Adamo 13, Adamo XPS, Alienware Alpha & Alienware Steam Machine, Alienware Alpha R2 & Alienware Steam Machine R2, Alienware Area 51, Alienware Area-51 ALX, Alienware Area-51 R2, Alienware Area-51 R4 and R5, Alienware Area-51 Threadripper Edition R3 and R6, Alienware Area-51 Threadripper Edition R7, Alienware Aurora, Alienware Aurora ALX, Alienware Aurora R2, Alienware Aurora R3, Alienware Aurora R4, Alienware Aurora R5, Alienware Aurora R6, Alienware Aurora R7, Alienware Aurora R8, Alienware X51, Alienware X51 R2, Alienware X51 R3, Alienware 15 R4, Alienware M17x,

Alienware 17, Alienware M17x R2, Alienware 17 R2, Alienware M17x R3, Alienware 17 R3, Alienware M17x R4, Alienware 15, Alienware 17 R4, Alienware M18x, Alienware 15 R2, Alienware 17 R5, Alienware m15, Alienware M18x R2, Alienware 15 R3, Alienware 18, Alienware M15x, Dell G7 15 7588, XPS 13 9370, XPS 13 9360, and XPS 13 9365 2-in-1 (collectively, the “Dell ‘979 Product(s)”).

553. The Dell ‘979 Products use Intel processors with integrated graphics processors including the following graphics processors: Intel UHD Graphics 630, Integrated GPU HD Cherry Trail, Integrated GPU HD 4200, Integrated GPU HD 4400, Integrated GPU HD 5000, Integrated GPU HD515, Integrated GPU HD520, Integrated GPU HD540, Integrated GPU HD 615, Integrated GPU HD 620, and Integrated GPU Iris Plus 640.

554. The Graphics Processing Units (“GPUs”) in the Dell ‘979 Products establish a window size and a sampling-window size, such that the window size is a multiple of the sampling-window size and the sampling-window size defines the fixed number of pixels; and

555. On information and belief, one or more Dell subsidiaries and/or affiliates use the Dell ‘979 Products in regular business operations.

556. On information and belief, one or more of the Dell ‘979 Products include technology for motion compensation in video signal processing.

557. On information and belief, Dell has directly infringed and continues to directly infringe the ‘979 patent by, among other things, making, using, offering for sale, and/or selling technology for motion compensation in video signal processing, including but not limited to the Dell ‘979 Products.

558. On information and belief, one or more of the Dell ‘979 Products use line buffers that are decoupled and that can deliver a fixed number of pixels, as may be required by a video

processing stage, using a sampling pattern that is defined as one among several selectable sampling windows.

559. On information and belief, one or more of the Dell ‘979 Products have a variable window size for sampling subsets of the array as a two-dimensional window that spans the pixels in the array.

Every on-die CPU core is regarded as a unique agent. Similarly, Intel processor graphics is treated as a unique agent on the interconnect ring. A system agent is also connected to the ring, which bundles the DRAM memory management unit, display controller, and other off chip I/O controllers such as PCI Express*. Importantly, all off-chip system memory transactions to/from CPU cores and to/from Intel processor graphics are facilitated by this interconnect, through the system agent, and the unified DRAM memory controller.

THE COMPUTE ARCHITECTURE OF INTEL PROCESSOR GRAPHICS GEN9 at 5 (August 14, 2015) (emphasis added).

560. On information and belief, one or more of the Dell ‘979 Products have a video processing stage that inputs pixels using a fixed number of pixels.

561. On information and belief, one or more of the Dell ‘979 Products performs a method for delivering the input stream of pixels to the video processing stage.

562. The following slide from an excerpt from an Intel presentation relating to the graphics processing unit that is including in the Dell ‘979 Products shows how the memory controller act as the interface between the graphics processor and memory structures include caches and off-chip memory.

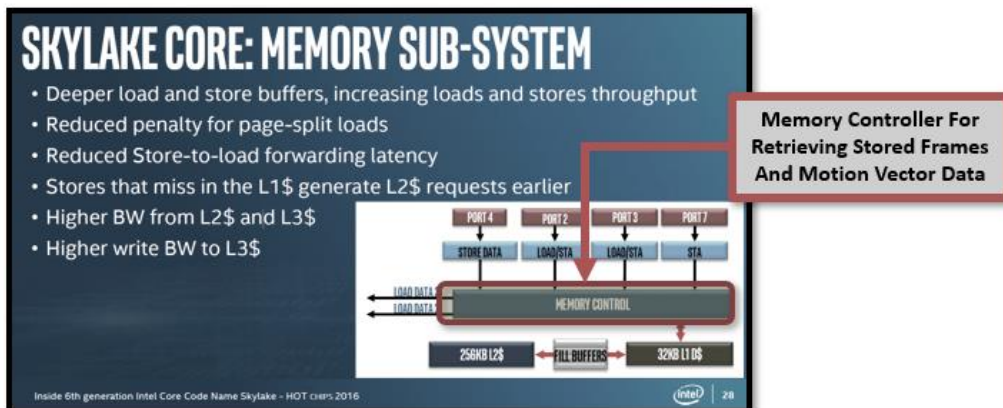

Jack Doweck, *Inside 6th Gen. Intel Core: New Microarchitecture Code Named Skylake*, INTEL PRESENTATION at 28 (2016) (annotation added).

563. On information and belief, one or more of the Dell ‘979 Products performs a method comprising establishing a window size and a sampling-window size, such that the window size is a multiple of the sampling-window size and the sampling-window size defines the fixed number of pixels.

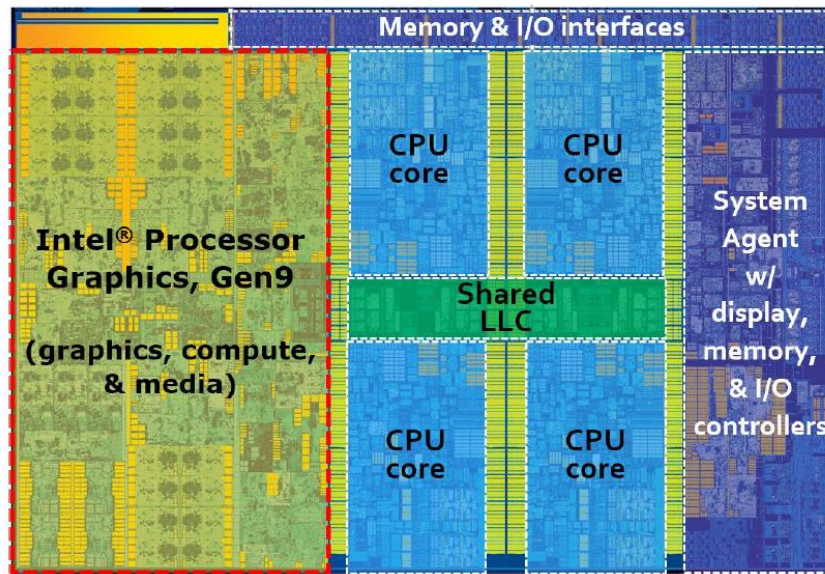

THE COMPUTE ARCHITECTURE OF INTEL PROCESSOR GRAPHICS GEN9 at 4 (August 14, 2015) (showing on the far right the display, memory and I/O controllers).

564. On information and belief, one or more of the Dell ‘979 Products performs a method comprising storing pixels from the input stream into a first set of line buffers, the pixels stored in the first set of line buffers including pixels for the established window size. Specifically, the Dell ‘979 Products contain an integrated Intel graphics processor in which pixels prior to display are stored in a line or frame buffer which is set to an established window size.

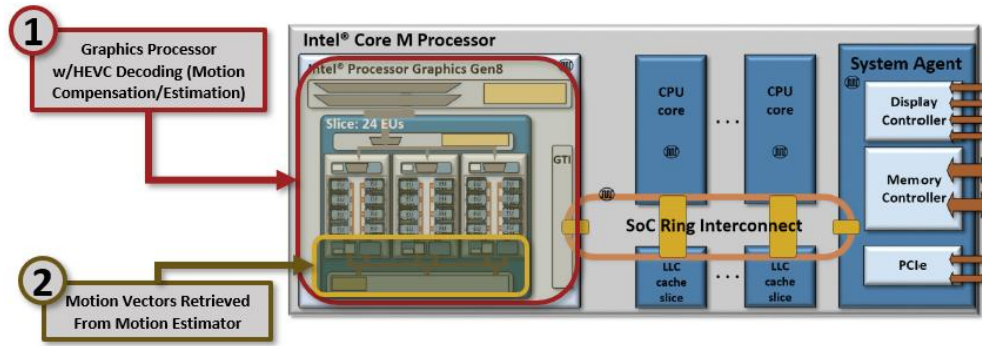

THE COMPUTE ARCHITECTURE OF INTEL PROCESSOR GRAPHICS GEN8 at 15 (July 15, 2015) (annotations added).

565. On information and belief, one or more of the Dell ‘979 Products performs a method comprising prefetching the stored pixels from the first set of line buffers into a second set of line buffers, the second set of line buffers being sufficiently long to store at least the pixels corresponding to the established sampling-window size.

566. On information and belief, one or more of the Dell ‘979 Products performs a method comprising fetching the fixed number of pixels from the second set of line buffers for the video processing stage.

567. On information and belief, one or more of the Dell ‘979 Products performs a method wherein storing pixels from the input stream into a first set of line buffers, the pixels stored in the first set of line buffers including pixels for the established window size, prefetching the stored pixels from the first set of line buffers into a second set of line buffers, and fetching the fixed number of pixels from the second set of line buffers for the video processing stage are performed concurrently.

568. On information and belief, the Dell ‘979 Products are available to businesses and individuals throughout the United States.

569. On information and belief, the Dell ‘979 Products are provided to businesses and individuals located in the Southern District of New York.

570. By making, using, testing, offering for sale, and/or selling products and services for motion compensation in video signal processing, including but not limited to the Dell ‘979 Products, Dell has injured Dynamic Data and is liable to the Plaintiff for directly infringing one or more claims of the ‘979 patent, including at least claim 1 pursuant to 35 U.S.C. § 271(a).

571. On information and belief, Dell also indirectly infringes the ‘979 patent by actively inducing infringement under 35 U.S.C. § 271(b).

572. Dell has had knowledge of the ‘979 patent since at least service of the Original Complaint in this case or shortly thereafter, and on information and belief, Dell knew of the ‘979 patent and knew of its infringement, including by way of this lawsuit.

573. On information and belief, Dell intended to induce patent infringement by third-party customers and users of the Dell ‘979 Products and had knowledge that the inducing acts would cause infringement or was willfully blind to the possibility that its inducing acts would cause infringement. Dell specifically intended and was aware that the normal and customary use of the accused products would infringe the ‘979 patent. Dell performed the acts that constitute induced infringement, and would induce actual infringement, with knowledge of the ‘979 patent and with the knowledge that the induced acts would constitute infringement. For example, Dell provides the Dell ‘979 Products that have the capability of operating in a manner that infringe one or more of the claims of the ‘979 patent, including at least claim 1, and Dell further provides documentation and training materials that cause customers and end users of the Dell ‘979 Products to utilize the products in a manner that directly infringe one or more claims of the ‘979 patent.²⁸⁷

²⁸⁷ See, e.g., *Dell G7 15*, SETUP AND SPECIFICATIONS (2018); *Alienware Graphics Amplifier*, USER’S GUIDE (2014); *Alienware Aurora R8*, SETUP AND SPECIFICATIONS (2018); *Alienware Alpha R2*, SETUP AND SPECIFICATIONS (2016); *Inspiron 15 7000 Gaming*, SERVICE MANUAL (2017-2018); *XPS 13*, SETUP AND SPECIFICATIONS (2017); *Alienware M17x R4*, OWNER’S MANUAL (2012).

By providing instruction and training to customers and end-users on how to use the Dell ‘979 Products in a manner that directly infringes one or more claims of the ‘979 patent, including at least claim 1, Dell specifically intended to induce infringement of the ‘979 patent. On information and belief, Dell engaged in such inducement to promote the sales of the Dell ‘979 Products, e.g., through Dell user manuals, product support, marketing materials, and training materials to actively induce the users of the accused products to infringe the ‘979 patent. Accordingly, Dell has induced and continues to induce users of the accused products to use the accused products in their ordinary and customary way to infringe the ‘979 patent, knowing that such use constitutes infringement of the ‘979 patent.

574. To the extent applicable, the requirements of 35 U.S.C. § 287(a) have been met with respect to the ‘979 patent.

575. As a result of Dell’s infringement of the ‘979 patent, Dynamic Data has suffered monetary damages, and seeks recovery in an amount adequate to compensate for Dell’s infringement, but in no event less than a reasonable royalty for the use made of the invention by Dell together with interest and costs as fixed by the Court.

PRAYER FOR RELIEF

WHEREFORE, Dynamic Data respectfully requests that this Court enter:

- A. A judgment in favor of Dynamic Data that Dell has infringed, either literally and/or under the doctrine of equivalents, the ‘105, ‘609, ‘073, ‘054, ‘918, ‘689, ‘177, ‘039, ‘112, ‘529, ‘230, ‘041, ‘450, and ‘979 patents;
- B. An award of damages resulting from Dell’s acts of infringement in accordance with 35 U.S.C. § 284;

- C. A judgment and order finding that Dell's infringement was willful, wanton, malicious, bad-faith, deliberate, consciously wrongful, flagrant, or characteristic of a pirate within the meaning of 35 U.S.C. § 284 and awarding to Dynamic Data enhanced damages.
- D. A judgment and order finding that this is an exceptional case within the meaning of 35 U.S.C. § 285 and awarding to Dynamic Data its reasonable attorneys' fees against Dell.
- E. Any and all other relief to which Dynamic Data may show themselves to be entitled.

JURY TRIAL DEMANDED

Pursuant to Rule 38 of the Federal Rules of Civil Procedure, Dynamic Data Technologies, LLC requests a trial by jury of any issues so triable by right.

Dated: February 4, 2019

Respectfully submitted,

/s/ Daniel P. Hipskind

Dorian S. Berger (*pro hac vice*)

Daniel P. Hipskind (*pro hac vice*)

Eric B. Hanson (*pro hac vice* to be filed)

BERGER & HIPSKIND LLP

9538 Brighton Way, Ste. 320

Beverly Hills, CA 90210

Telephone: 323-886-3430

Facsimile: 323-978-5508

E-mail: dsb@bergerhipskind.com

E-mail: dph@bergerhipskind.com

E-mail: ebh@bergerhipskind.com

Attorneys for Dynamic Data

Technologies, LLC

CERTIFICATE OF SERVICE

I hereby certify that counsel of record who are deemed to have consented to electronic service are being served this 4th of February, 2019 with a copy of this document via the Court's CM/ECF System.

/s/ Daniel P. Hipskind

Daniel P. Hipskind