

IN THE UNITED STATES DISTRICT COURT  
FOR THE WESTERN DISTRICT OF TEXAS  
WACO DIVISION

SLINGSHOT PRINTING LLC,

Plaintiff,

v.

HP INC.,

Defendant.

C.A. No. 6:19-cv-00549

**Jury Trial Demanded**

**COMPLAINT FOR PATENT INFRINGEMENT**

Plaintiff Slingshot Printing LLC (“Slingshot”) files this Complaint against Defendant HP Inc. (“HP”) for patent infringement of United States Patent Nos. 6,213,587; 6,575,563; 6,676,246; 6,786,575; 7,018,012; 7,195,341; 7,290,864; 7,410,246; 7,484,823 and 7,559,629 (the “patents-in-suit”) (Exhibits 1-10) and alleges as follows:

**NATURE OF THE ACTION**

1. This is an action for patent infringement arising under the patent laws of the United States, 35 U.S.C. §§ 1 *et seq.*

**THE PARTIES**

2. Plaintiff Slingshot Printing LLC is a Delaware limited liability company with its principal place of business at 8455 Colesville Road, Suite 830, Silver Spring, MD 20910.

3. On information and belief, HP Inc. is a Delaware corporation with a place of business at 1501 Page Mill Road, Palo Alto, CA 94304. On information and belief,

since May 1998, HP has been registered to do business in the State of Texas under Texas SOS file Number 0012093906. On information and belief, since at least 2016, HP has had a place of business at 3800 Quick Hill Rd #100, Austin, TX 78728.

### JURISDICTION AND VENUE

4. This Court has jurisdiction over the subject matter of this action pursuant to 28 U.S.C. §§ 1331 and 1338(a) because the action arises under the patents laws of the United States, 35 U.S.C. §§ 1 *et seq.*

5. Venue is proper in this judicial district pursuant to 28 U.S.C. §§ 1391(b), (c), (d) and/or 1400(b).

6. HP is subject to this Court's personal jurisdiction, in accordance with due process and/or the Texas Long Arm Statute because HP "[r]ecruits Texas residents, directly or through an intermediary located in this state, for employment inside or outside this state." *See* Tex. Civ. Prac. & Rem. Code § 17.042.

7. This Court has personal jurisdiction over HP because, on information and belief, HP and its authorized resellers (or those acting on their behalf) and HP's customers committed and continue to commit acts of patent infringement in this judicial district. On information and belief, HP and its authorized resellers (or those acting on their behalf) make, use, sell, offer to sell and/or import HP inkjet products (including, without limitation, infringing inkjet printers, inkjet printheads, ink cartridges and associated accessories) in this judicial district and provide associated services in this judicial district. On information and belief, HP customers use HP inkjet

products (including, without limitation, infringing inkjet printers, inkjet printheads, ink cartridges and associated accessories) in this judicial district.

8. This Court has personal jurisdiction over HP because, *inter alia*, HP, on information and belief: (1) has committed acts of patent infringement in this judicial district, (2) has substantial, continuous, and systematic business contacts in this judicial district; (3) owns, manages and operates facilities in this judicial district; (4) enjoys substantial income from its operations, sales and services in this judicial district, (5) employs Texas residents in this judicial district and (5) solicits business and markets products and services in this judicial district including infringing products. As such, HP has purposefully availed itself of the privileges of conducting business within this judicial district; has established sufficient minimum contacts with this judicial district such that it should reasonably and fairly anticipate being hauled into court in this judicial district; has purposefully directed activities at residents of this judicial district; and at least a portion of the patent infringement claims alleged in this Complaint arise out of or are related to one or more of the foregoing activities.

9. On information and belief, HP maintains a significant physical presence in this judicial district. Specifically, HP has a corporate office at 3800 Quick Hill Rd #100, Austin, TX 78728 (“Austin Office”). On information and belief, HP has data centers located in Austin, Texas.



Image capture: Apr 2019 Images may be subject to copyright.

Source: Google Streetview of 3800 Quick Hill Road (attached as Exhibit 11)

(<https://www.google.com/maps/place/HP+Inc./@30.4703733,-97.6859262,3a,75y,90t/data=!3m8!1e2!3m6!1sAF1QipNp5EYyUhJS0qXzzgDwzf8UoOVahLIBmo2QpSjR!2e10!3e12!6shttps:%2F%2Fh5.googleusercontent.com%2Fp%2FAF1QipNp5EYyUhJS0qXzzgDwzf8UoOVahLIBmo2QpSjR%3Dw213-h120-k-no!7i4000!8i2250!4m13!1m7!3m6!1s0x8644ce11dbcc242d:0x5804b8f52b061c45!2s3800+Quick+Hill+Rd,+Austin,+TX+78728!3b1!8m2!3d30.4708993!4d-97.6876364!3m4!1s0x8644ce11dbcc242d:0xeceb1885722ffa93!8m2!3d30.4703733!4d-97.6859262>).

10. On information and belief, HP uses the Austin Office as a regular and established place of business. A number of key HP employees work in the Austin Office including, but not limited, to a Director of IT, a Director of Governmental Affairs as well as software and hardware engineers.

11. HP's website lists fifty-one H-1B labor condition applications for people employed in Austin, Texas. *See* Exhibit 12 (<http://www.hp.com/hpinfo/>). Employees holding an H-1B visa are employed in a specialty occupation that requires "theoretical and practical application of a body of highly specialized knowledge . . . and attainment of a bachelor's or higher degree in the specific specialty. . . ." *See generally* 8 U.S.C. §

1184. As such, HP employees in Austin, Texas are highly specialized and important to the operation of HP.

12. HP lists job opening on its website for positions in Austin, Texas. See Exhibit 13 (<https://h30631.www3.hp.com/search-jobs/Austin?orgIds=3544&alp=6252001-4736286-4671654&alt=4>) (as of 9/18/19).

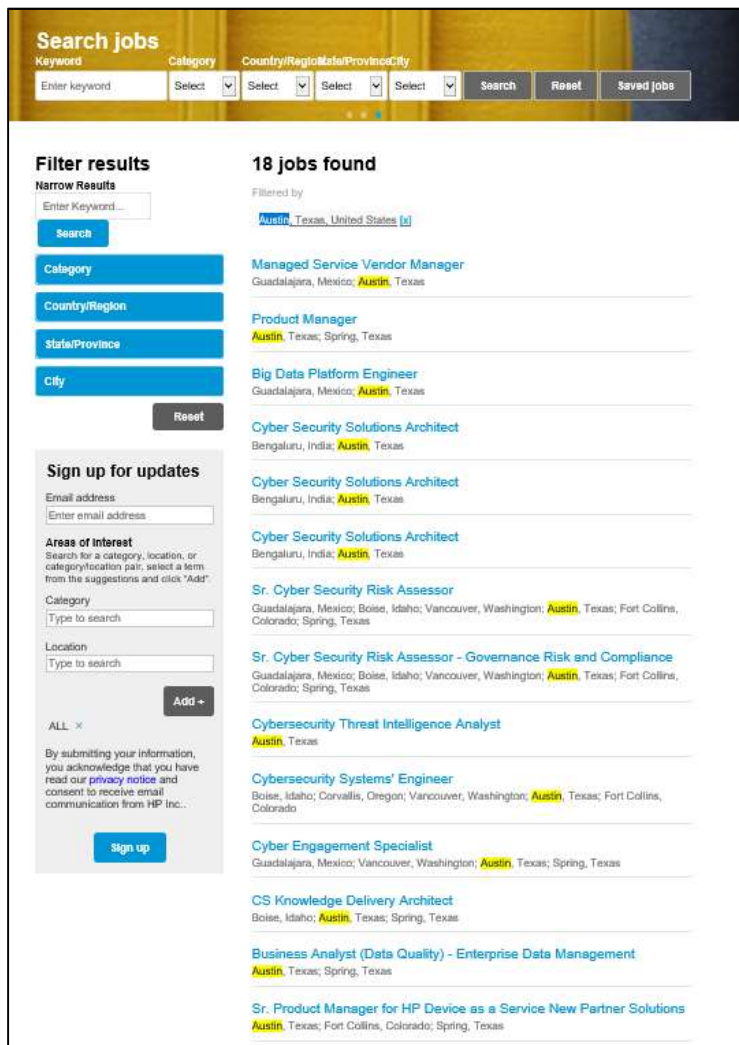

13. On information and belief, HP owns real estate in the Austin, Texas including properties at (a) 7501 N. Capital of Texas Highway, Austin, TX 78731, (b) 3301

Hibbets Rd, Austin, TX 78721, (c) 14231 Tandem Blvd, Austin, TX 78728 and (d) 14219 Tandem Blvd, Austin, TX 78728.

14. HP operates the HP Partners First Program throughout the United States including in this judicial district. *See generally*, Exhibit 14 (HP Partners First Program Brochure). This program is a partnership agreement between HP and retailers throughout the area that “is focused on being first in sales, speed and solutions, offering a comprehensive framework that encompasses a broad range of partner motions.”

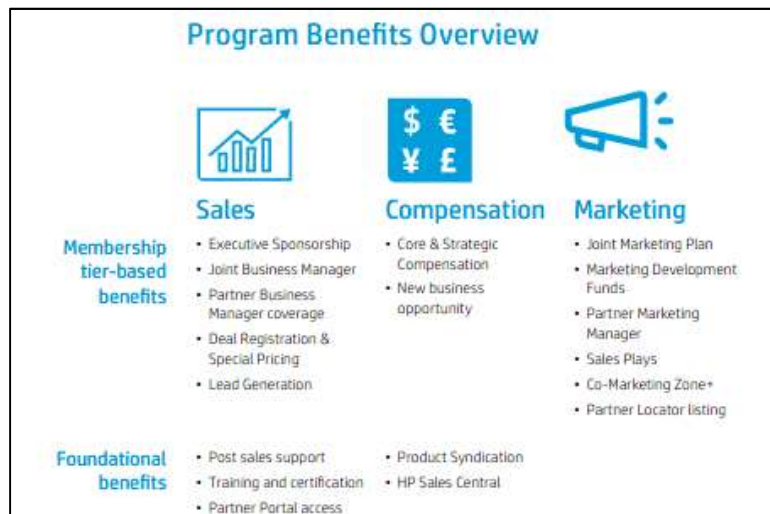

*See* Exhibit 14 at page 10.

15. The HP Partners First Program includes three tiers of partnership: Silver, Gold, and Platinum. At every level, the partners are required to enter into a formal Partner agreement with HP and provide sales certified printing, computing and supplies. *Id.* at 11. HP provides market development funds to Platinum members. *Id.* at 15. According to HP, “HP places great value in partnership with reseller partners contributing significantly towards HP’s business revenue. Visibility of partner’s

business are critical component towards fine-tuning of collaborative sales effort.” *Id* at 44.

16. Through the HP Partners First Program, HP has hundreds of partners physically located throughout this judicial district including, but not limited to, HP partners in Waco, Austin, and San Antonio. HP’s website provides existing and potential customers with the ability to search for resellers based on cities or zip codes in this judicial district. A search on HP’s website for Waco, Austin, and San Antonio provides the names and locations of numerous HP resellers:

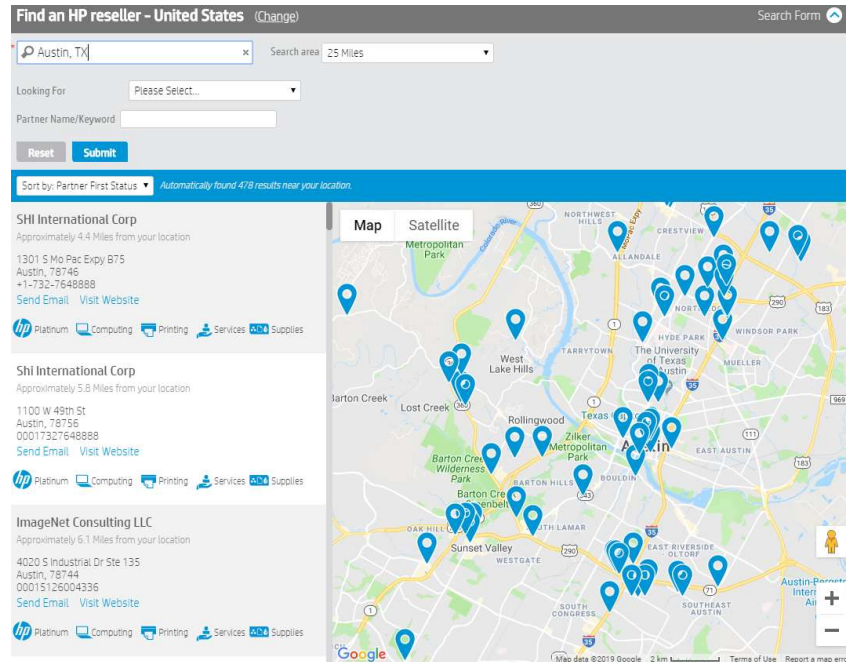

Austin, Texas

**Find an HP reseller - United States** (Change) Search Form

Waco, TX Search area: 25 Miles

Looking For: Please Select...

Partner Name/Keyword:

Reset Submit

Sort by: Partner First Status Automatically found 536 results near your location.

**SHI International Corp**  
 Approximately 148.1 Miles from your location  
 1100 W 49th St  
 Austin, 78756  
 00017327648888  
[Send Email](#) [Visit Website](#)

HP Platinum Computing Printing Services Supplies

**En Pointe Technologies Sales Llc**  
 Approximately 155.1 Miles from your location  
 1120 S CAPITAL OF TEXAS HWY  
 WEST LAKE HILLS, 78746  
 00013103376151  
[Send Email](#) [Visit Website](#)

HP Platinum Computing Printing Supplies

**SHI International Corp**  
 Approximately 155.8 Miles from your location  
 1301 S Mo Pac Expy B75  
 Austin, 78746  
 +1-732-7648888  
[Send Email](#) [Visit Website](#)

HP Platinum Computing Printing Services Supplies

Map Satellite

Map data ©2019 Google 10 km

Waco, Texas

**Find an HP reseller - United States** (Change) Search Form

San Antonio, TX Search area: 25 Miles

Looking For: Please Select...

Partner Name/Keyword:

Reset Submit

Sort by: Partner First Status Automatically found 520 results near your location.

**ARC Document Solutions LLC**  
 Approximately 1.2 Miles from your location  
 600 BRdway  
 SAN ANTONIO, 78215  
 +1-210-2277181  
[Send Email](#) [Visit Website](#)

HP Platinum Computing Printing Services Supplies

**The Stewart Organization Inc**  
 Approximately 14.2 Miles from your location  
 11905 STARCREST DR  
 SAN ANTONIO, 78247  
 2107456600  
[Send Email](#) [Visit Website](#)

HP Platinum Printing Supplies

**Intech Southwest Services LLC**  
 Approximately 15.2 Miles from your location  
 4778 RESEARCH DR  
 SAN ANTONIO, 78240  
 2106900000  
[Send Email](#) [Visit Website](#)

HP Platinum Computing Printing Services Supplies

Map Satellite

Map data ©2019 Google 5 km

San Antonio, Texas

17. A search of the Austin, Texas area returns results for at least fifty-nine partners participating in the HP Partners First Program. Fifteen of those partners are



platinum partners who offer HP computing, printing, services and supplies to consumers in the Austin area. A search of the Waco, Texas area returns results for at least seven partners participating in the HP Partners First Program. All of those partners are Silver partners of the HP Partners First Program, and at least one of those silver members offers HP computing, printing and supplies to consumers in the Waco area. A search of the San Antonio, Texas area returns results for at least fifty-five partners participating in the HP Partners First Program. Seventeen of those partners are platinum partners who offer HP computing, printing, services and supplies to consumers in the San Antonio area.

18. ImageNet Consulting LLC is listed as a Platinum Partner selling printing services in Austin:



According to ImageNet Consulting LLC's website, the company offers several printers for sale including the HP PageWide Pro MFP P57750 and HP PageWide Managed E55650dn. See Exhibit 15 (<http://www.imagenetconsulting.com/products/copiers-printers-scanners/workteam-printers/>).

19. Texepro LLC is listed as a Silver Partner selling printing services in Waco:

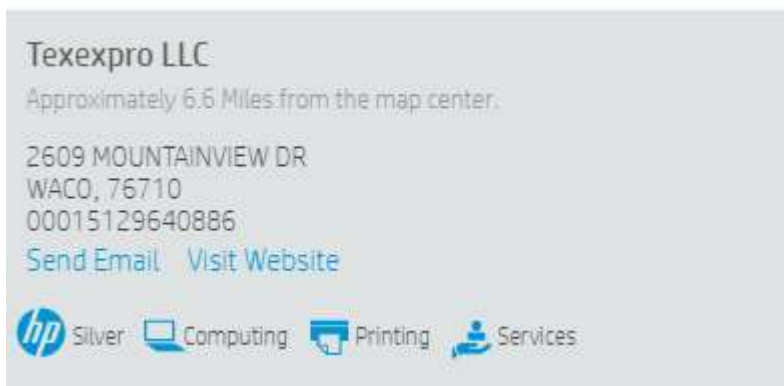

According to Texepro LLC's website, the company offers several printers for sale including the HP OfficeJet 4650. See Exhibit 16 (<https://www.texepro.com/copy-of-products>).

20. ARC Document Solutions LLC is listed as a Platinum Partner selling printing services in San Antonio:

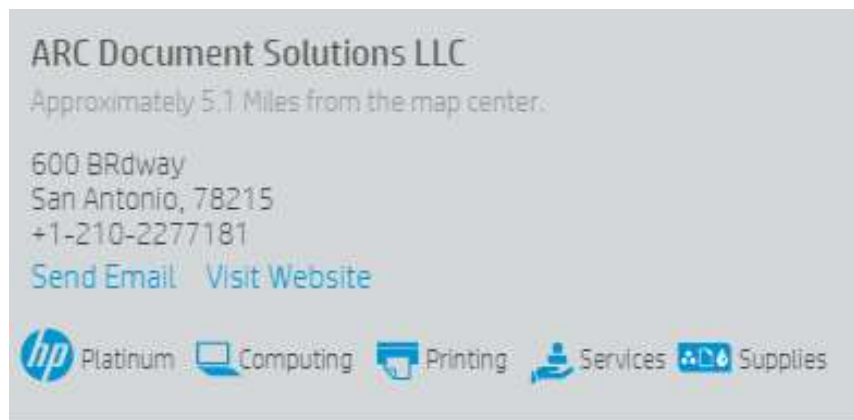

According to Arc Document Solutions LLC's website, the company offers several printers for sale including the HP PageWide Enterprise Color 556dn Color Printer, HP PageWide Pro 750dw Color Printer, and the HP PageWide Pro 452dw Color Printer. See Exhibit 17 (<http://shop.arcsupplies.com/store/c-527-ink-printers.aspx>).

21. Consumers in this judicial district are also able to purchase infringing inkjet printers, inkjet printheads and ink cartridges directly from HP through its online website and have products delivered in this judicial district.

<https://store.hp.com/us/en>.

22. HP sells its products including, without limitation, infringing inkjet printers, inkjet printheads and ink cartridges through stores located in this judicial district such as Best Buy, S.P. Richards Co., Staples Inc. and Fry's Electronics.

23. On information and belief, HP has previously litigated patent infringement cases before this Court without contesting jurisdiction and venue. *See Neodron, Ltd. v. HP Inc.*, Case No. 1:19-cv-00873-ADA and *Iron Oak Technologies, LLC v. HP Inc.*, Case No. 17-cv-1068, W.D. Texas.

## **BACKGROUND**

### **The Patents-in-Suit**

24. The patents-in-suit are the result of Lexmark International, Inc.'s ("Lexmark") many years of researching, designing and developing innovative and proprietary inkjet printing technologies.

25. Lexmark was formed in 1991 when IBM divested a number of its hardware manufacturing operations. Lexmark became a leading developer, manufacturer and supplier of inkjet printers, ink cartridges and their associated supplies and services.

26. Lexmark's research and development activity focused on, *inter alia*, inkjet printers, ink cartridges and printer supplies. Lexmark spent billions of dollars on

research and development – \$375 million in 2009, \$423 million in 2008, \$401 million in 2007, \$371 million in 2006, \$336 million in 2005, \$312 million in 2004, \$266 million in 2003, \$247 million in 2002, \$246 million in 2001, \$217 million in 2000, and \$184 million in 1999.

27. By April 2013, Lexmark held approximately 1,500 inkjet patents worldwide. Indeed, Lexmark’s intellectual property was one of its major assets. Recognizing the tremendous value of Lexmark’s intellectual property, in 2013, Funai Electric Co., Ltd. (“Funai”) acquired Lexmark’s inkjet printing technology and assets, including the patents-in-suit, for approximately \$100 million.

28. Funai subsequently assigned Slingshot all rights, title and interest in the patents-in-suit.

### **Inkjet Printer Technology**

29. The patents-in-suit relate to inkjet printer technology.

30. Inkjet printers have one or more printheads and multiple ink cartridges. The ink cartridges store different colors of ink (e.g., black, magenta, yellow, cyan) and provide the ink to the printhead(s) during printing.

31. Each printhead has hundreds of tiny nozzles through which tiny ink droplets are deposited onto a substrate (e.g., paper) during printing. In particular, the printhead is located on a carriage that moves back and forth across the substrate and deposits ink on the substrate as the substrate advances through the printer. For certain printers, the printhead is located on the ink cartridges themselves. For other printers, the printhead(s) are separate from the ink cartridges.

**United States Patent No. 6,213,587**

32. On April 10, 2001, the United States Patent and Trademark Office (“USPTO”) duly and legally issued United States Patent No. 6,213,587 (“the ‘587 patent”) entitled “Ink jet printhead having improved reliability” to inventor Charles S. Whitman. A true and correct copy of the ‘587 patent is attached as Exhibit 1.

33. The ‘587 patent relates to, among other things, an inkjet printhead, inkjet printer and a method for increasing the life of an inkjet printhead.

34. The ‘587 patent is presumed valid under 35 U.S.C. § 282.

35. Slingshot owns all rights, title, and interest in the ‘587 patent.

**United States Patent No. 6,575,563**

36. On June 10, 2003, the USPTO duly and legally issued United States Patent No. 6,575,563 (“the ‘563 patent”) entitled “Power/volume regime for ink jet printers” to inventor Robert W. Cornell. A true and correct copy of the ‘563 patent is attached as Exhibit 2.

37. The ‘563 patent relates to, among other things, an inkjet printer for forming printed images by ejecting droplets of ink at a stable velocity onto a print medium and method thereof.

38. The ‘563 patent is presumed valid under 35 U.S.C. § 282.

39. Slingshot owns all rights, title, and interest in the ‘563 patent.

**United States Patent No. 6,676,246**

40. On January 13, 2004, the USPTO duly and legally issued United States Patent No. 6,676,246 (“the ‘246A patent”) entitled “Heater construction for minimum

pulse time” to inventors Frank E. Anderson and Robert W. Cornell. A true and correct copy of the ‘246A patent is attached as Exhibit 3.

41. The ‘246A patent relates to, among other things, an inkjet printer for forming printed images by ejecting droplets of ink onto a print medium and a method for printing with an inkjet printer.

42. The ‘246A patent is presumed valid under 35 U.S.C. § 282.

43. Slingshot owns all rights, title, and interest in the ‘246A patent.

**United States Patent No. 6,786,575**

44. On September 7, 2004, the USPTO duly and legally issued United States Patent No. 6,786,575 (“the ‘575 patent”) entitled “Ink jet heater chip and method therefor” to inventors Frank E. Anderson and George K. Parish. A true and correct copy of the ‘575 patent is attached as Exhibit 4.

45. The ‘575 patent relates to, among other things, an inkjet heater chip having improved thermal efficiency.

46. The ‘575 patent is presumed valid under 35 U.S.C. § 282.

47. Slingshot owns all rights, title, and interest in the ‘575 patent.

**United States Patent No. 7,018,012**

48. On March 28, 2006, the USPTO duly and legally issued United States Patent No. 7,018,012 (“the ‘012 patent”) entitled “Microfluid ejection device having efficient logic and driver circuitry” to inventors J. Glenn Edelen, George K. Parish and Kristi M. Rowe. A true and correct copy of the ‘012 patent is attached as Exhibit 5.

49. The '012 patent relates to, among other things, a semiconductor substrate for a microfluid ejection head/inkjet printhead and a microfluid ejection cartridge.

50. The '012 patent is presumed valid under 35 U.S.C. § 282.

51. Slingshot owns all rights, title, and interest in the '012 patent.

**United States Patent No. 7,195,341**

52. On March 27, 2007, the USPTO duly and legally issued United States Patent No. 7,195,341 ("the '341 patent") entitled "Power and ground buss layout for reduced substrate size" to inventors David G. King and Kristi M. Rowe. A true and correct copy of the '341 patent is attached as Exhibit 6.

53. The '341 patent relates to, among other things, a semiconductor substrate for a micro-fluid ejection device.

54. The '341 patent is presumed valid under 35 U.S.C. § 282.

55. Slingshot owns all rights, title, and interest in the '341 patent.

**United States Patent No. 7,290,864**

56. On November 6, 2007, the USPTO duly and legally issued United States Patent No. 7,290,864 ("the '864 patent") entitled "Heater chips with a reduced number of bondpads" to inventor David G. King. A true and correct copy of the '864 patent is attached as Exhibit 7.

57. The '864 patent relates to, among other things, a heater chip for use in a printing device.

58. The '864 patent is presumed valid under 35 U.S.C. § 282.

59. Slingshot owns all rights, title, and interest in the '864 patent.

**United States Patent No. 7,410,246**

60. On August 12, 2008, the USPTO duly and legally issued United States Patent No. 7,410,246 (“the ‘246B patent”) entitled “Heater chip configuration for an inkjet printhead and printer” to inventors Byron V. Bell, Robert W. Cornell and Yimin Guan. A true and correct copy of the ‘246B patent is attached as Exhibit 8.

61. The ‘246B patent relates to, among other things, a heater chip for an inkjet printhead, an inkjet printhead and an inkjet printer.

62. The ‘246B patent is presumed valid under 35 U.S.C. § 282.

63. Slingshot owns all rights, title, and interest in the ‘246B patent.

**United States Patent No. 7,484,823**

64. On February 3, 2009, the USPTO duly and legally issued United States Patent No. 7,484,823 (“the ‘823 patent”) entitled “Methods and apparatuses for regulating the temperature of multi-via heater chips” to inventors Lucas D. Barkley, Bruce D. Gibson, Eric S. Hall, David G. King and George K. Parish. A true and correct copy of the ‘823 patent is attached as Exhibit 9.

65. The ‘823 patent relates to, among other things, a chip for use with a printing device and a method of fabricating chips for use with a printing device.

66. The ‘823 patent is presumed valid under 35 U.S.C. § 282.

67. Slingshot owns all rights, title, and interest in the ‘823 patent.

**United States Patent No. 7,559,629**

68. On July 14, 2009, the USPTO duly and legally issued United States Patent No. 7,559,629 (“the ‘629 patent”) entitled “Methods and apparatuses for implementing



multi-via heater chips” to inventor David G. King. A true and correct copy of the ‘629 patent is attached as Exhibit 10.

69. The ‘629 patent relates to, among other things, a chip for use in a printing device and an integrated multi-via heater chip.

70. The ‘629 patent is presumed valid under 35 U.S.C. § 282.

71. Slingshot owns all rights, title, and interest in the ‘629 patent.

### **CLAIMS FOR RELIEF**

#### **Count I - Infringement of United States Patent No. 6,213,587**

72. The allegations set forth above are re-alleged and incorporated by reference as if they were set forth fully here.

73. HP makes, uses, sells, offers to sell and/or imports inkjet printers and inkjet printheads in the United States that infringe (literally and/or under the doctrine of equivalents) at least claims 1-3, 7, 11 and 29-34 of the ‘587 patent. HP commits acts of patent infringement through the manufacture, use, sale, offer for sale and/or importation of at least the following products:

**Inkjet printers** including, without limitation, HP Latex 115, 315, 335 Print and Cut;

HP Latex 115, 310, 315, 330, 335, 360, 365, 560, 570.

**Inkjet printheads** including, without limitation, HP 831.

74. On information and belief, inkjet printers listed above are sold with inkjet printheads and ink cartridges. The inkjet printheads and ink cartridges can also be purchased separately from the inkjet printer. The inkjet printheads and ink cartridges are necessary for the operation of the inkjet printers and vice versa.

75. Infringement of the '587 patent by the inkjet printers and inkjet printheads is demonstrated below using the HP 831 printhead as an example.

76. HP makes, uses, sells, offers to sell and/or imports an inkjet printhead (e.g., HP 831 printhead ("HP 831")).



77. The HP 831 has a transducer (resistive heater transducer), at least a portion of which is arranged within a chamber (firing chamber).

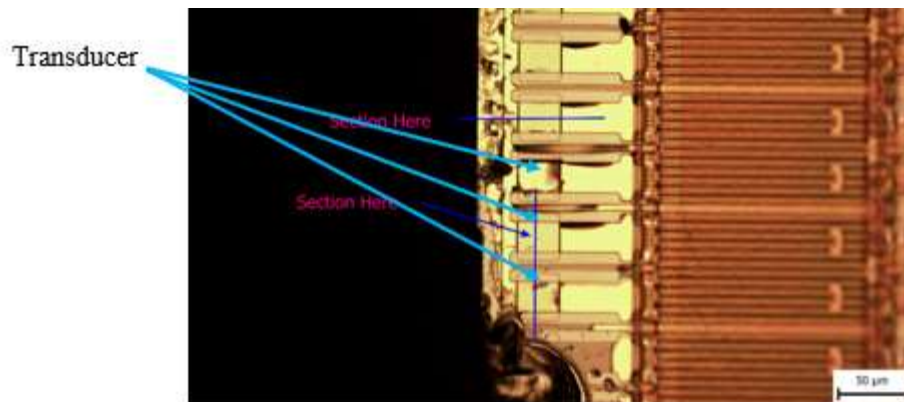

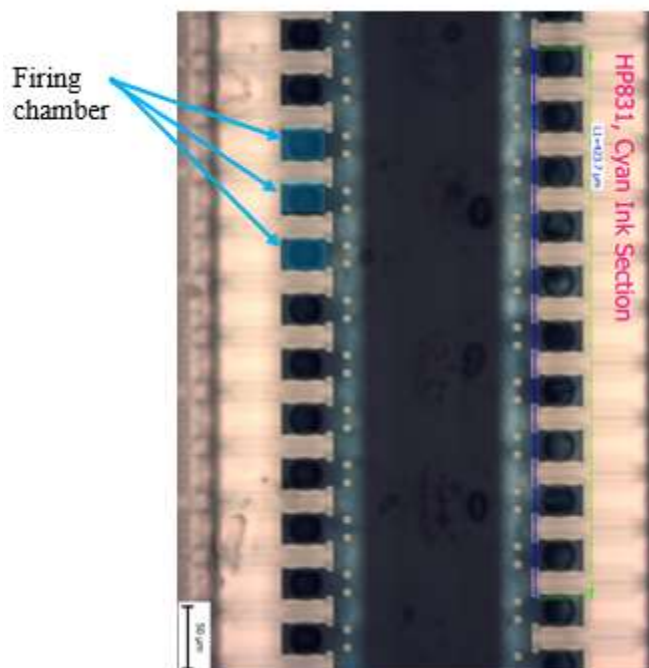

78. The HP 831 has a plate (nozzle plate) having apertures (nozzles) capable of cooperating with the chamber to allow ink to be ejected from the chamber.

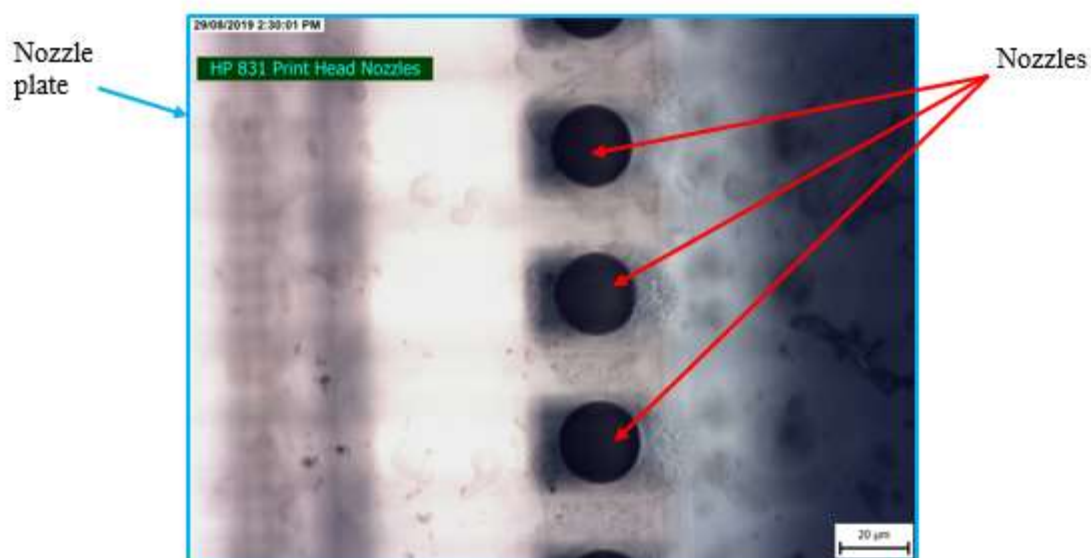

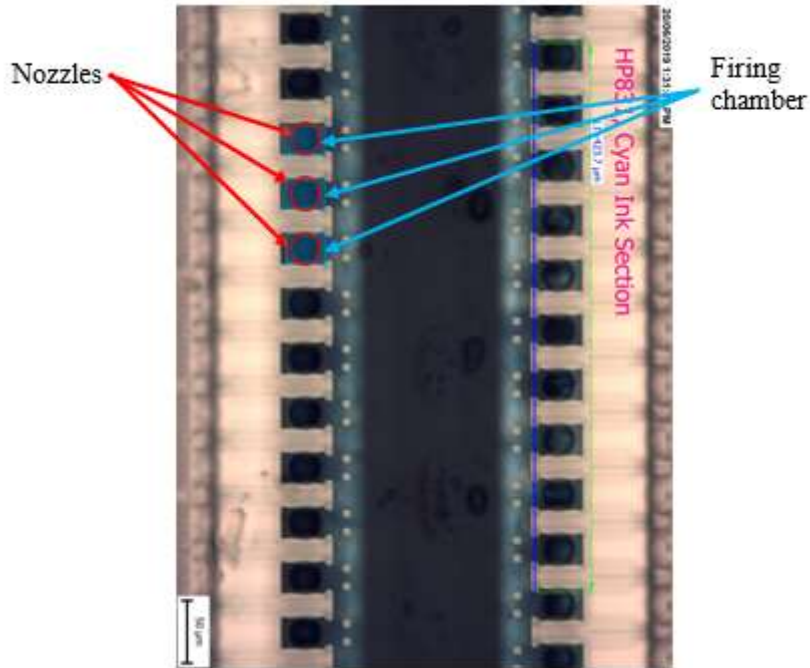

79. The nozzle plate has a thickness of about 13.4  $\mu\text{m}$  (microns) which is less than 62 microns.

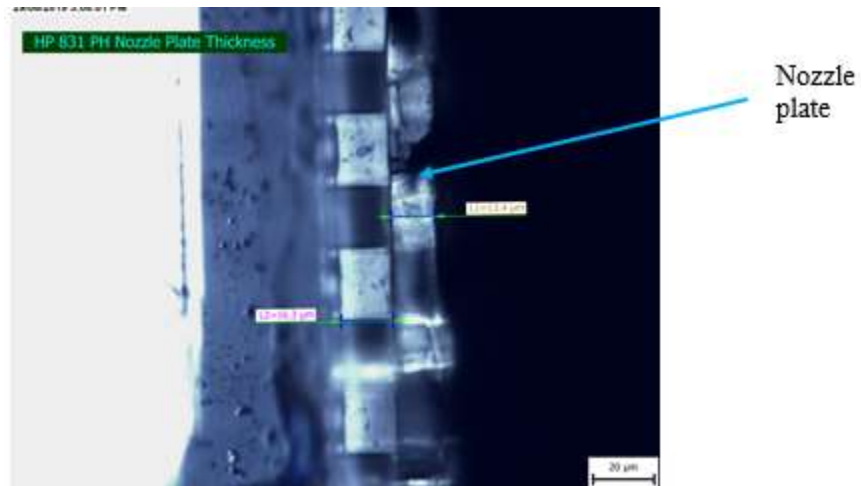

80. On information and belief, based on the heater material, heater area and firing pulse widths, the transducer of the HP 831 is capable of being selectively energized with a power density less than 2.159  $\text{GW}/\text{m}^2$  (and less than about 2  $\text{GW}/\text{m}^2$ ) to cause droplets of ink to be ejected from the chamber.

81. The heater resistor of the HP 831 has an area of approximately  $622 \mu\text{m}^2$  ( $29.6 \mu\text{m} \times 21.0 \mu\text{m}$ ).

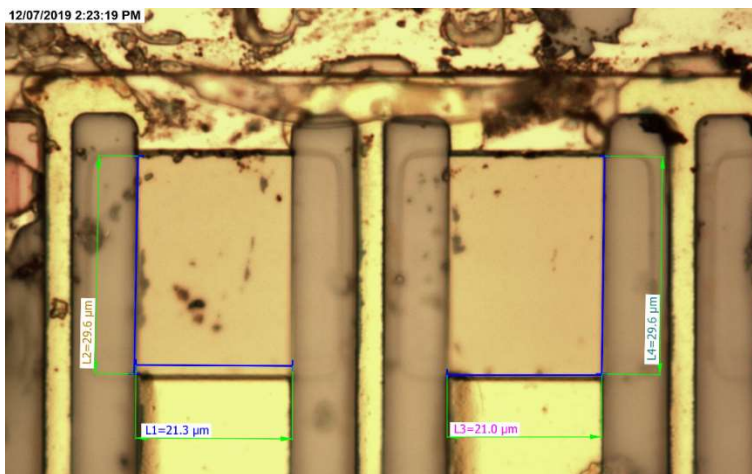

82. The HP 831 has a heater resistor (shown in cross section, below left) made of WSiN (Tungsten-Silicon-Nitride).

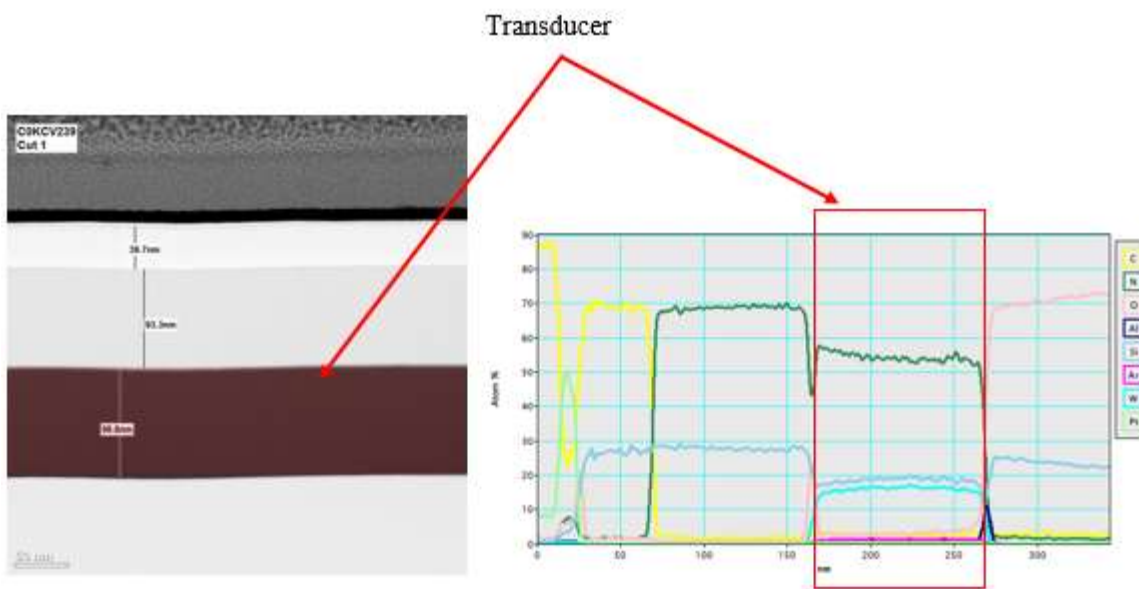

83. The nozzle plate of the HP 831 is separated from the transducer by about  $16.3 \mu\text{m}$  (microns) - a distance of less than 28 microns and between about 8 to about 27 microns.

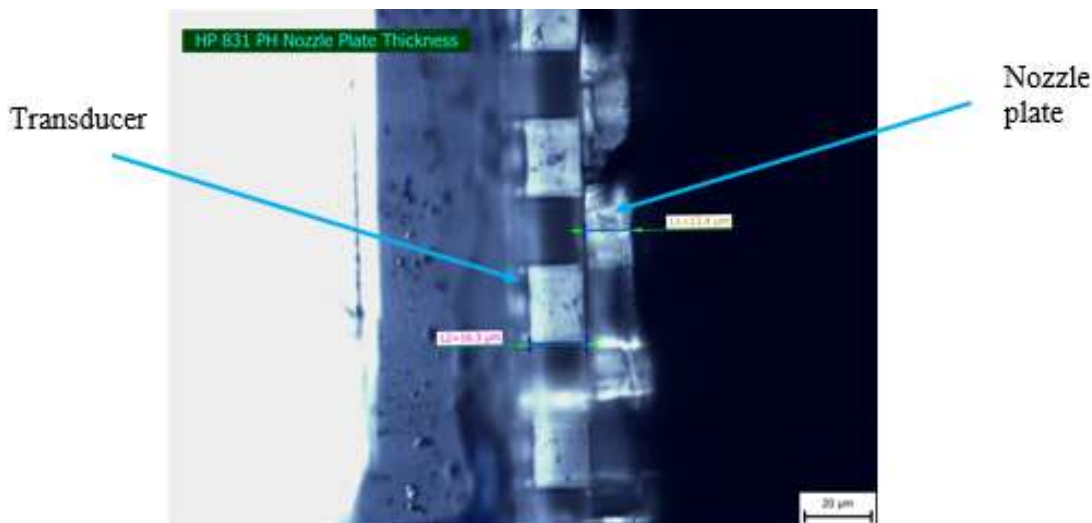

84. The nozzle plate has a thickness of 13.4  $\mu\text{m}$  (microns) which is less than about 60 microns.

85. The inkjet printers identified above comprise the printhead described above and a power source (e.g., main controller board) capable of selectively energizing the transducer with a power density less than 2.159  $\text{GW}/\text{m}^2$  to cause droplets of the ink to be ejected from the chamber.

86. On information and belief, HP (or those on its behalf) performs a method for increasing the life of an inkjet printhead (e.g., HP 831) which includes a transducer to heat an ink droplet.

87. On information and belief, HP (or those on its behalf) arranges at least a portion of the transducers of the HP 831 within a chamber (firing chamber).

88. On information and belief, HP (or those on its behalf) provides a plate (nozzle plate) having apertures (nozzles) capable of cooperating with the chamber to

allow ink to be ejected from the chamber where the plate has a thickness of less than 62 microns.

89. On information and belief, software installed by HP (or those on its behalf) in the HP printers listed above cause the printers to selectively energize the transducer of the HP 831 with a power density less than 2.159 GW/m<sup>2</sup> to cause droplets of ink to be ejected from the chamber.

90. On information and belief, HP (or those on its behalf) separates the nozzle plate of the HP 831 from the transducer by 16.3 μm (microns) – a distance of less than 28 microns.

91. On information and belief, HP has been on notice of the '587 patent at least as early as the filing and service of the Complaint in *Slingshot Printing LLC v. HP Inc.*, C.A. No. 6:19-cv-00363 (W.D. Tex. June 11, 2019).

92. On information and belief, at least since its post-filing knowledge of the '587 patent, HP knowingly encourages, and continues to encourage, customers and resellers to directly infringe one or more claims of the '587 patent, including by HP's actions that include, without limitation, instructing and encouraging customers to use (and resellers to use, sell and offer to sell) HP inkjet printers and inkjet printheads through HP's user guides/manuals, advertisement, promotional materials and instructions.

93. On information and belief, at least since its post-filing knowledge of the '587 patent, HP knows that the acts HP induced customers and resellers to take

constitute patent infringement and HP's encouraging acts result in direct infringement by customers and resellers.

94. On information and belief, HP instructs and continues to instruct customers and resellers to setup, use and troubleshoot HP inkjet printers and inkjet printheads including, without limitation, on HP's website which provides support on setting up and/or using these products.

95. On information and belief, HP's customers directly infringe at least claims 1-3, 7, 11 and 29-32 of the '587 patent through their setup and use of HP inkjet printers and inkjet printheads.

96. On information and belief, HP's resellers directly infringe at least claims 1-3, 7, 11 and 29-32 of the '587 patent through their setup, use, sale and offer for sale of HP inkjet printers and inkjet printheads.

97. On information and belief, HP is in violation of 35 U.S.C. § 271(b) and has been, at least since its post-filing knowledge of the '587 patent, indirectly infringing and continues to indirectly infringe at least claims 1-3, 7, 11 and 29-32 of the '587 patent by knowingly and specifically intending to induce infringement by others (including, without limitation, HP's customers and resellers) and possessing specific intent to encourage infringement by HP's customers and resellers. HP inkjet printheads are specifically configured according to the claims of the '587 patent, are material parts of the invention and do not have substantial non-infringing uses.



98. Slingshot has been damaged by the direct and/or indirect infringement of HP and is suffering and will continue to suffer irreparable harm and damages as a result of this infringement.

**Count II - Infringement of United States Patent No. 6,575,563**

99. The allegations set forth above are re-alleged and incorporated by reference as if they were set forth fully here.

100. HP makes, uses, sells, offers to sell and/or imports inkjet printers and inkjet printheads in the United States that infringe (literally and/or under the doctrine of equivalents) at least claims 1, 2, 5, 7, 8 and 11 of the '563 patent. HP commits acts of patent infringement through the manufacture, use, sale, offer for sale and/or importation of at least the following products:

**Inkjet printers** including, without limitation, HP Latex 115, 315, 335 Print and Cut; HP Latex 115, 310, 315, 330, 335, 360, 365, 560, 570.

**Inkjet printheads** including, without limitation, HP 831.

101. On information and belief, inkjet printers listed above are sold with inkjet printheads and ink cartridges. The inkjet printheads and ink cartridges can also be purchased separately from the inkjet printer. The inkjet printheads and ink cartridges are necessary for the operation of the inkjet printers and vice versa.

102. Infringement of the '563 patent by the inkjet printers and inkjet printheads is demonstrated below using the HP Latex 115 printer/HP 831 printhead as an example.

103. HP makes, uses, sells, offers to sell and/or imports inkjet printers (e.g., HP Latex 115 (“HP Latex Printer”)).



104. The HP Latex Printer forms printed images by ejecting droplets of ink at a stable velocity onto a print medium (e.g., paper).

105. The HP Latex Printer has an ink jet printhead – HP 831 printhead (“HP 831”).

106. The HP 831 has a plurality of nozzles through which droplets of ink are ejected.

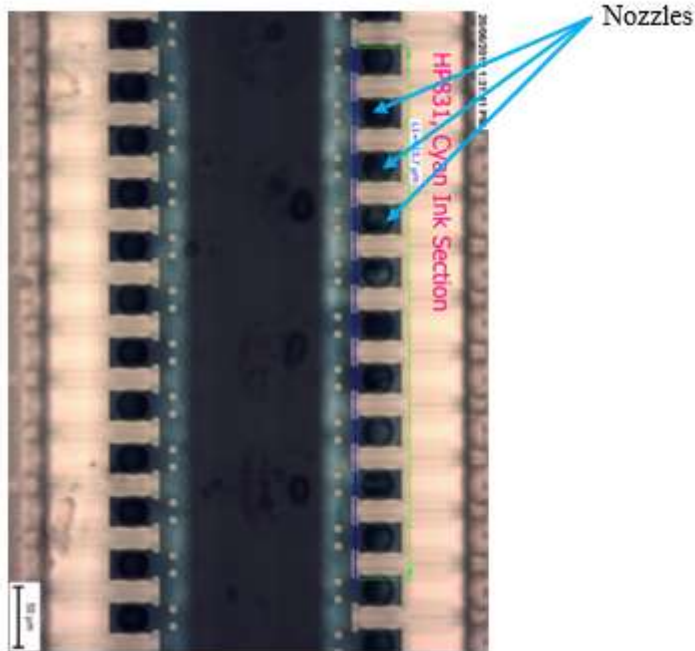

107. The HP 831 has a heater chip that has a plurality of heating elements. Each heating element is associated with a nozzle.

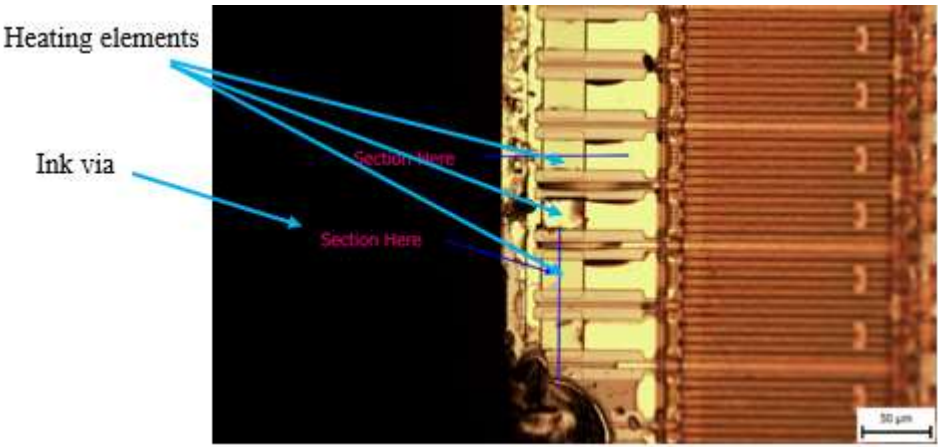

108. Each heating element of the HP 831 transfers heat into adjacent ink (e.g., ink that flows over the heating element from the ink via) at a rate of heat transfer (e.g., watts/unit area necessary to boil ink on the surface of heating element) which is predetermined (e.g., determined based on parameters set in the software of the HP

Latex Printer). The predetermined rate of heat transfer is sufficient to maintain the stable velocity of the droplets of ink under a range of conditions during printing.

109. When a predetermined minimum power level (e.g., voltage over time) is applied to the heating element of the HP 831, the predetermined rate of heat transfer is accomplished. In particular, circuitry of the HP 831 provides a voltage to the heating element for a period of time (a firing pulse width). The voltage and period of time are predetermined in that they are based on parameters set in the software of the HP Latex Printer. Using a predetermined voltage and period of time results in a predetermined rate of heat transfer.

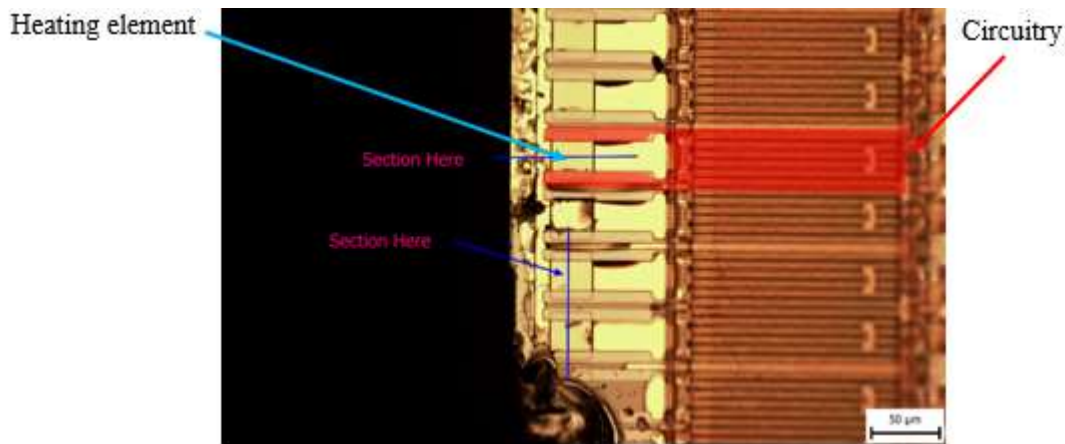

110. The HP 831 has a heater resistor (shown in cross section, below left) made of WSiN (Tungsten-Silicon-Nitride). As a resistive material, WSiN has a thermal capacitance value.

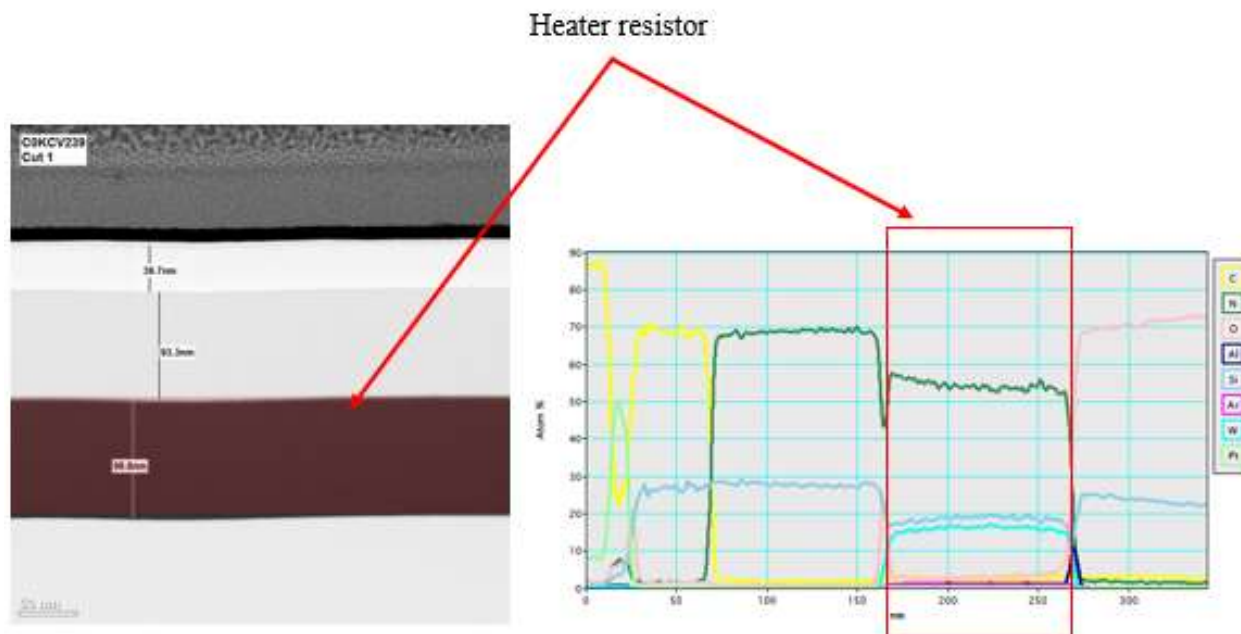

111. The heater resistor of the HP 831 has an area of approximately  $622 \mu\text{m}^2$  ( $29.6 \mu\text{m} \times 21.0 \mu\text{m}$ ).

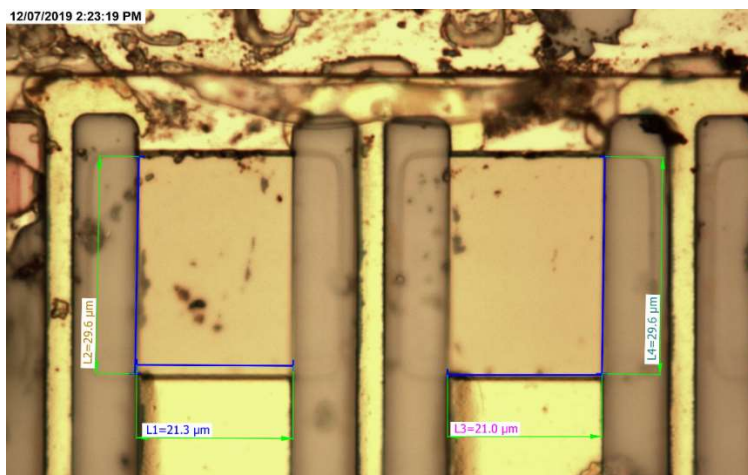

112. The heater resistor of the HP 831 has a thickness of 98.8 nm.

113. On information and belief, when the predetermined minimum power level is applied to the heater resistor of the HP 831, the heater resistor is operable to provide a predetermined minimum power density per unit area.

114. The HP 831 has a protective layer (shown in cross section, below left) adjacent the heater resistor. The protective layer is made of SiN (Silicon-Nitride) with a thickness of 93.3 nm and SiC (Silicon-Carbide) with a thickness of 39.7 nm. As resistive materials, SiN and SiC have thermal capacitance values.

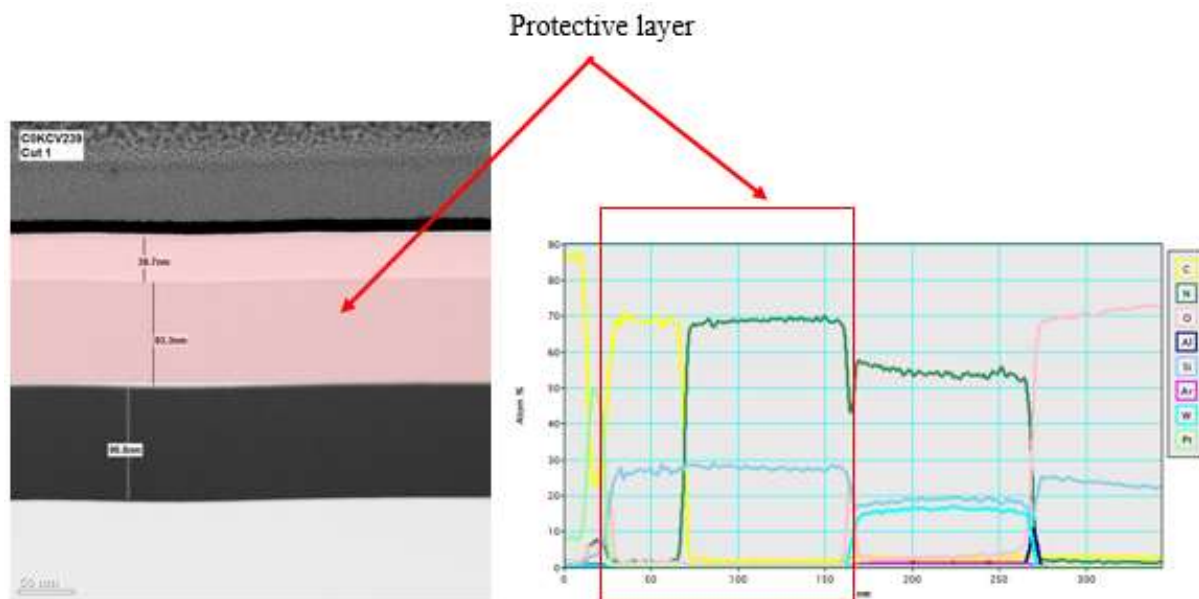

115. The heater resistor area of the HP 831 ( $622 \mu\text{m}^2$ ) multiplied by a sum of the heater resistor thickness and the protective layer thickness ( $98.8 \text{ nm} + 93.3 \text{ nm} + 39.7 \text{ nm} = 231.8 \text{ nm}$  or  $0.2318 \mu\text{m}$ ) represents a heating element volume.

116. On information and belief, when the predetermined minimum power level (e.g., voltage over time) is applied to a heater resistor of the HP 831, the heating element is operable to provide a predetermined minimum power density per unit volume within the heating element volume. The predetermined minimum power density per unit volume is determined by dividing the predetermined minimum power

density per unit area by the sum of the heater resistor thickness and the protective layer thickness.

117. The HP 831 has a power supply (e.g., main controller board) coupled to the plurality of heater resistors for providing the predetermined minimum power level to the heater resistors.

118. On information and belief, based on the HP 831 heater material, area and thickness and across a range of firing pulse widths, the power supply of the HP 831 provides the predetermined minimum power level sufficient to generate the predetermined minimum power density per unit volume greater than about  $1.5 \times 10^{15}$  watts per cubic meter.

119. The heater resistor area of the HP 831 is  $622 \mu\text{m}^2$  and the heater resistor thickness is  $98.8 \text{ nm}$  ( $988 \text{ \AA}$ ) which is about  $900 \text{ \AA}$ .

120. The protective layer of the HP 831 comprises multiple layers of material – SiN layer and SiC layer.

121. HP performs a method of printing with an inkjet printer by ejecting droplets of ink at a stable velocity onto a print medium by (a) providing a thermal ink jet print head having a plurality of nozzles through which the droplets of ink are ejected, and having a heater chip which includes a plurality of heating elements, each heating element associated with a corresponding one of the plurality of nozzles, each heating element comprising a heater resistor having a heater resistor area and a heater resistor thickness, and a protective layer adjacent the heater resistor having a protective layer thickness, where the heater resistor area multiplied by a sum of the heater resistor

thickness and the protective layer thickness represents a heating element volume; and  
(b) providing a power density per unit volume within the heating element volume of at least about  $1.5 \times 10^{15}$  watts per cubic meter.

122. On information and belief, HP has been on notice of the '563 patent at least as early as the filing and service of the Complaint in this action.

123. On information and belief, at least since its post-filing knowledge of the '563 patent, HP knowingly encourages, and continues to encourage, customers and resellers to directly infringe one or more claims of the '563 patent, including by HP's actions that include, without limitation, instructing and encouraging customers to use (and resellers to use, sell and offer to sell) HP inkjet printers and inkjet printheads through HP's user guides/manuals, advertisement, promotional materials and instructions.

124. On information and belief, at least since its post-filing knowledge of the '563 patent, HP knows that the acts HP induced customers and resellers to take constitute patent infringement and HP's encouraging acts result in direct infringement by customers and resellers.

125. On information and belief, HP instructs and continues to instruct customers and resellers to setup, use and troubleshoot HP inkjet printers and inkjet printheads including, without limitation, on HP's website which provides support on setting up and/or using these products.



126. On information and belief, HP's customers directly infringe at least claims 1, 2, 5, 7, 8 and 11 of the '563 patent through their setup and use of HP inkjet printers and inkjet printheads.

127. On information and belief, HP's resellers directly infringe at least claims 1, 2, 5, 7, 8 and 11 of the '563 patent through their setup, use, sale and offer for sale of HP inkjet printers and inkjet printheads.

128. On information and belief, HP is in violation of 35 U.S.C. § 271(b) and has been, at least since its post-filing knowledge of the '563 patent, indirectly infringing and continues to indirectly infringe at least claims 1, 2, 5, 7, 8 and 11 of the '563 patent by knowingly and specifically intending to induce infringement by others (including, without limitation, HP's customers and resellers) and possessing specific intent to encourage infringement by HP's customers and resellers. HP inkjet printheads are specifically configured according to the claims of the '563 patent, are material parts of the invention and do not have substantial non-infringing uses.

129. Slingshot has been damaged by the direct and/or indirect infringement of HP and is suffering and will continue to suffer irreparable harm and damages as a result of this infringement.

**Count III - Infringement of United States Patent No. 6,676,246**

130. The allegations set forth above are re-alleged and incorporated by reference as if they were set forth fully here.

131. HP makes, uses, sells, offers to sell and/or imports inkjet printers and inkjet printheads in the United States that infringe (literally and/or under the doctrine

of equivalents) at least claims 1, 4, 5, 6, 8 and 11 of the '246A patent. HP commits acts of patent infringement through the manufacture, use, sale, offer for sale and/or importation of at least the following products:

**Inkjet printers** including, without limitation, HP Latex 115, 315, 335 Print and Cut; HP Latex 115, 310, 315, 330, 335, 360, 365, 560, 570.

**Inkjet printheads** including, without limitation, HP 831.

132. On information and belief, inkjet printers listed above are sold with inkjet printheads and ink cartridges. The inkjet printheads and ink cartridges can also be purchased separately from the inkjet printer. The inkjet printheads and ink cartridges are necessary for the operation of the inkjet printers and vice versa.

133. Infringement of the '246A patent by the inkjet printers and inkjet printheads is demonstrated below using the HP Latex 115 printer/HP 831 printhead as an example.

134. HP makes, uses, sells, offers to sell and/or imports inkjet printers (e.g., HP Latex 115 ("HP Latex Printer")).



135. The HP Latex Printer forms printed images by ejecting droplets of ink onto a print medium (e.g., paper).

136. The HP Latex Printer has a power supply (e.g., main controller board).

137. The HP Latex Printer has an ink jet printhead - HP 831 printhead ("HP 831"). The HP 831 is powered by the power supply and in communication with an ink supply (e.g., the ink supply in HP 831 and/or HP 831 ink cartridges).



138. The HP 831 has a plurality of nozzles through which the droplets of ink are ejected.

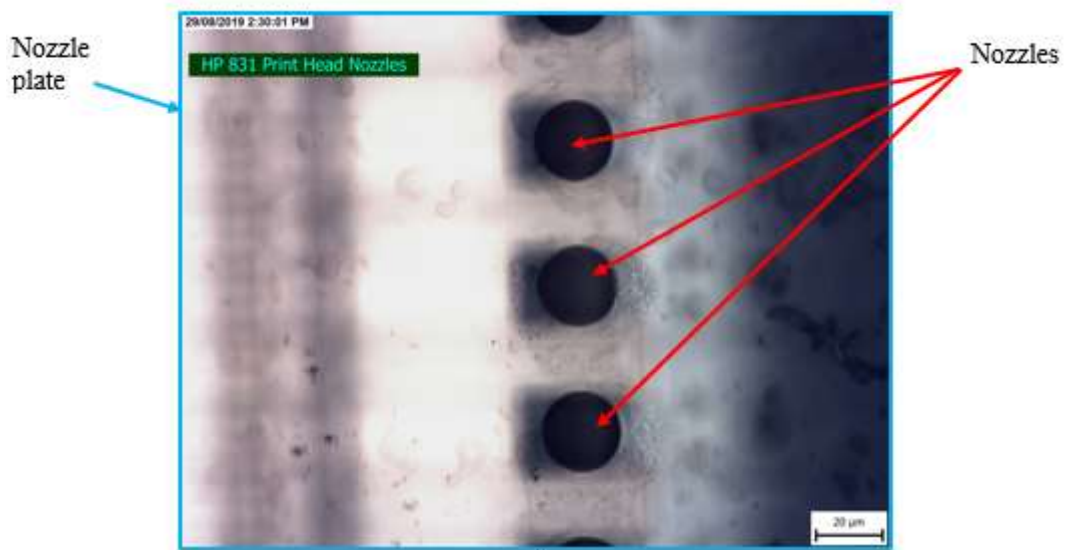

139. The HP 831 has a heater chip having a plurality of heating elements. Each heating element has a heating resistor.

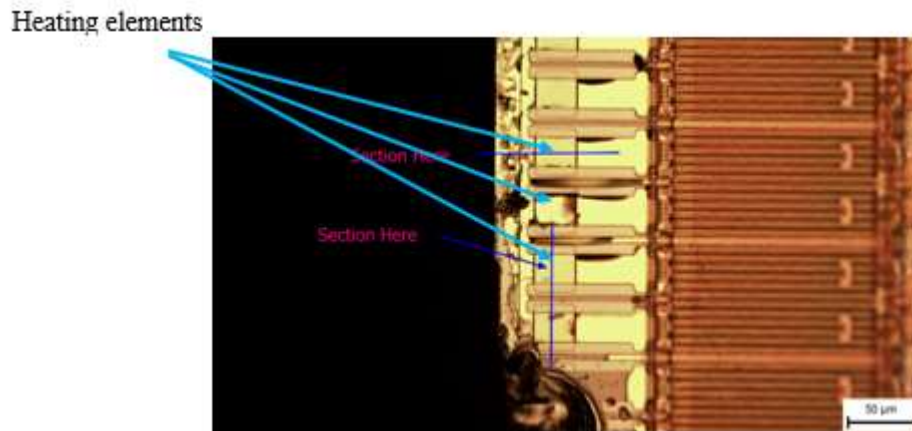

140. The HP 831 has a heating resistor (shown in cross section, below left) in electrical communication with the power supply. The heating resistor is made of WSiN (Tungsten-Silicon-Nitride).

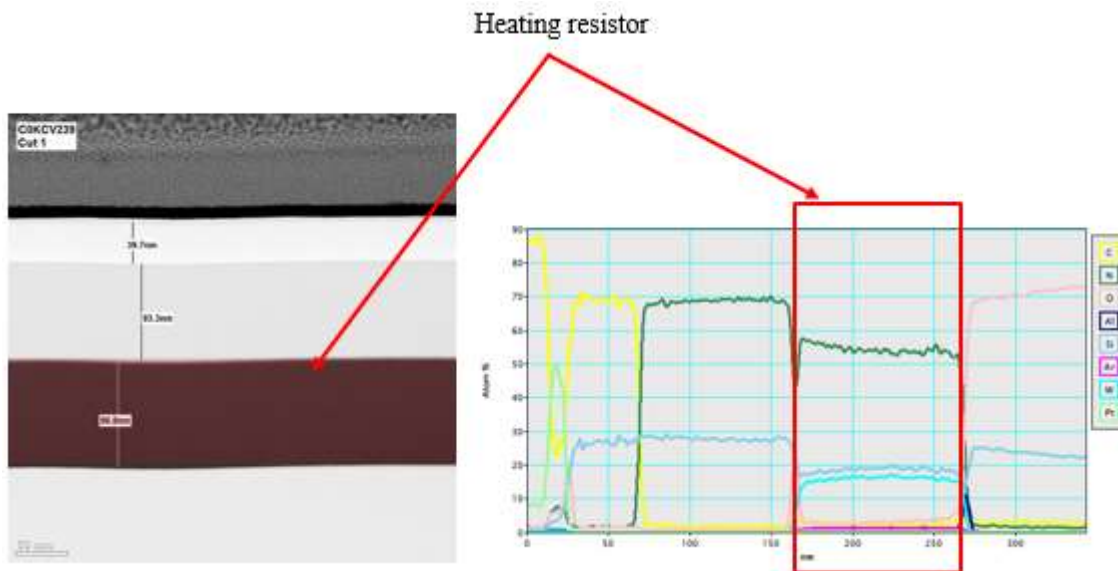

141. The heating resistor of the HP 831 has an area of approximately  $622 \mu\text{m}^2$  ( $29.6 \mu\text{m} \times 21.0 \mu\text{m}$ ).

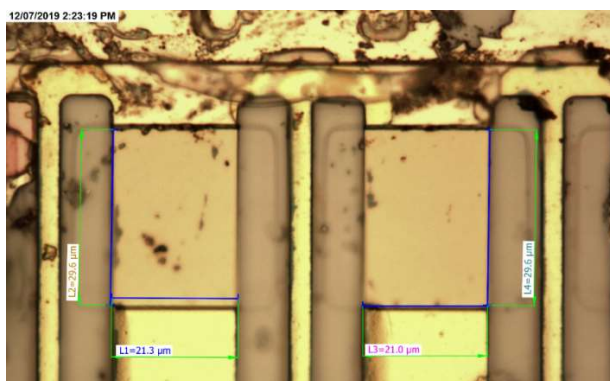

142. The heater resistor of the HP 831 has a thickness of 98.8 nm.

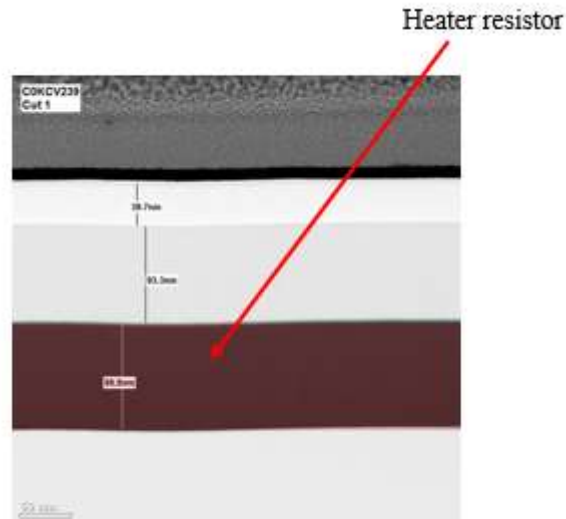

143. The HP 831 has a protective layer (shown in cross section, below left) having a thickness of less than about 7200 Angstroms (within a range of about 1000 to about 7200 Angstroms) overlying the heating resistor. The protective layer is made of SiN (Silicon-Nitride) with a thickness of 93.3 nm and SiC (Silicon-Carbide) with a thickness of 39.7 nm. The protective layer has a thickness of 1330 Angstroms (133 nm).

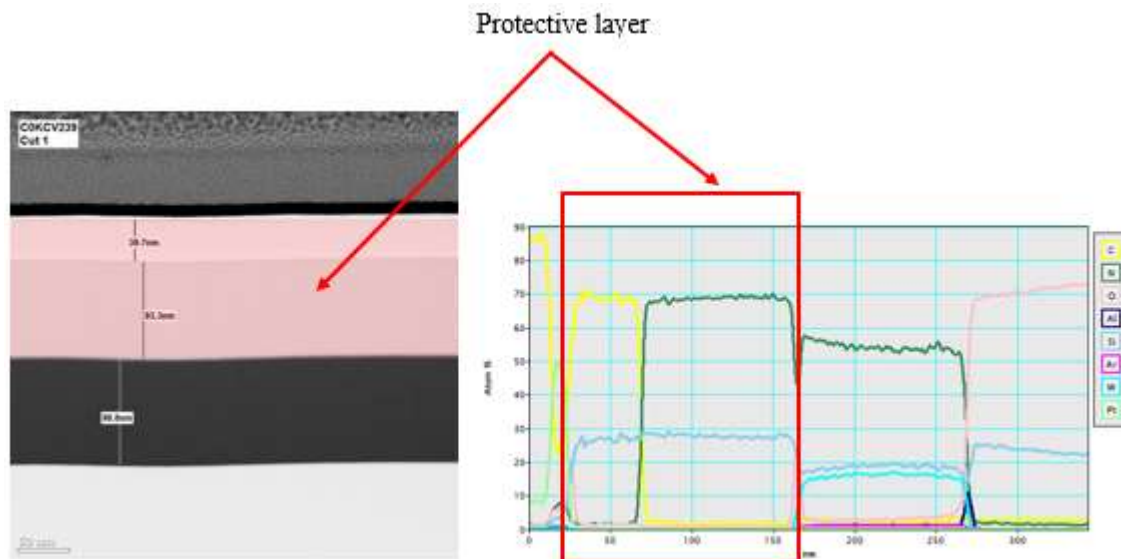

144. Each each heating element of the HP 831 has a volume (area multiplied by a thickness) and is associated with a corresponding one of the plurality of nozzles for

transferring heat into adjacent ink for a period of time corresponding to a pulse time of less than about 0.73 microseconds to achieve ejection of the ink through the nozzle in response to energy being supplied to the heater resistor by the power supply. On information and belief, based on the dimensions of a heating element and materials making up the heating element, the HP 831 will produce a stable ink droplet with a pulse time (firing pulse width) of less than about 0.73 microseconds.

145. On information and belief, the energy supplied to each of the heater resistor ranges from about  $2.9 \text{ GJ/m}^3$  to about  $4.0 \text{ GJ/m}^3$  based on the volume of the heating element.

146. The volume of the heating element of the HP 831 is determined by multiplying the area of the heater resistor ( $622 \text{ } \mu\text{m}^2$ ) by the sum of the thickness of the heater resistor and the thickness of the protective layer ( $98.8 \text{ nm} + 93.3 \text{ nm} + 39.7 \text{ nm} = 231.8 \text{ nm}$  or  $0.2318 \text{ } \mu\text{m}$ ).

147. The HP 831 has a heater chip structure having heating elements that, on information and believe, are operable at an energy per unit volume of from about  $2.9 \text{ GJ/m}^3$  to about  $4.0 \text{ GJ/m}^3$ , a pulse time of less than about 0.73 microseconds and one or more protective layers having a total thickness of less than about 7200 angstroms.

148. On information and belief, HP has been on notice of the '246A patent at least as early as the filing and service of the Complaint in this action.

149. On information and belief, at least since its post-filing knowledge of the '246A patent, HP knowingly encourages, and continues to encourage, customers and resellers to directly infringe one or more claims of the '246A patent, including by HP's

actions that include, without limitation, instructing and encouraging customers to use (and resellers to use, sell and offer to sell) HP inkjet printers and inkjet printheads through HP's user guides/manuals, advertisement, promotional materials and instructions.

150. On information and belief, at least since its post-filing knowledge of the '246A patent, HP knows that the acts HP induced customers and resellers to take constitute patent infringement and HP's encouraging acts result in direct infringement by customers and resellers.

151. On information and belief, HP instructs and continues to instruct customers and resellers to setup, use and troubleshoot HP inkjet printers and inkjet printheads including, without limitation, on HP's website which provides support on setting up and/or using these products.

152. On information and belief, HP's customers directly infringe at least claims 1, 4, 5, 6, 8 and 11 of the '246A patent through their setup and use of HP inkjet printers and inkjet printheads.

153. On information and belief, HP's resellers directly infringe at least claims 1, 4, 5, 6, 8 and 11 of the '246A patent through their setup, use, sale and offer for sale of HP inkjet printers and inkjet printheads.

154. On information and belief, HP is in violation of 35 U.S.C. § 271(b) and has been, at least since its post-filing knowledge of the '246A patent, indirectly infringing and continues to indirectly infringe at least claims 1, 4, 5, 6, 8 and 11 of the '246A patent by knowingly and specifically intending to induce infringement by others (including,



without limitation, HP's customers and resellers) and possessing specific intent to encourage infringement by HP's customers and resellers. HP inkjet printheads are specifically configured according to the claims of the '246A patent, are material parts of the invention and do not have substantial non-infringing uses.

155. Slingshot has been damaged by the direct and/or indirect infringement of HP and is suffering and will continue to suffer irreparable harm and damages as a result of this infringement.

**Count IV - Infringement of United States Patent No. 6,786,575**

156. The allegations set forth above are re-alleged and incorporated by reference as if they were set forth fully here.

157. HP makes, uses, sells, offers to sell and/or imports inkjet printers and ink cartridges in the United States that infringe (literally and/or under the doctrine of equivalents) at least claims 1, 4 and 6 of the '575 patent. HP commits acts of patent infringement through the manufacture, use, sale, offer for sale and/or importation of at least the following products:

**Inkjet printers** including, without limitation, HP DeskJet D4260, D4263, D4268, D4360, D4363, D4368; HP OfficeJet J5725, J5730, J5735, J5738, J5740, J5750, J5780, J5783, J5785, J5788, J5790, J6410, J6415 All-in-One, J6424.

**Ink cartridges/printheads** including, without limitation, HP 75XL tricolor.

158. On information and belief, inkjet printers listed above are sold with ink cartridges. The ink cartridges include an inkjet printhead. The ink cartridges can also

be purchased separately from the inkjet printer. The ink cartridges are necessary for the operation of the inkjet printers and vice versa.

159. Infringement of the '575 patent by the ink cartridges and associated inkjet printers is demonstrated below using the HP 75XL tri-color as an example.

160. HP makes, uses, sells, offers to sell and/or imports the HP 75XL tri-color ("HP 75XL"). The HP 75XL includes an ink jet heater chip having improved thermal efficiency.



161. The HP 75XL has a semiconductor substrate, a first metal resistive layer on the substrate and a second metal conductive layer on a first portion of the resistive layer and on a second portion of the resistive layer. The second metal conductive layer defines a heater resistor element between the first and second portions of the resistive layer.

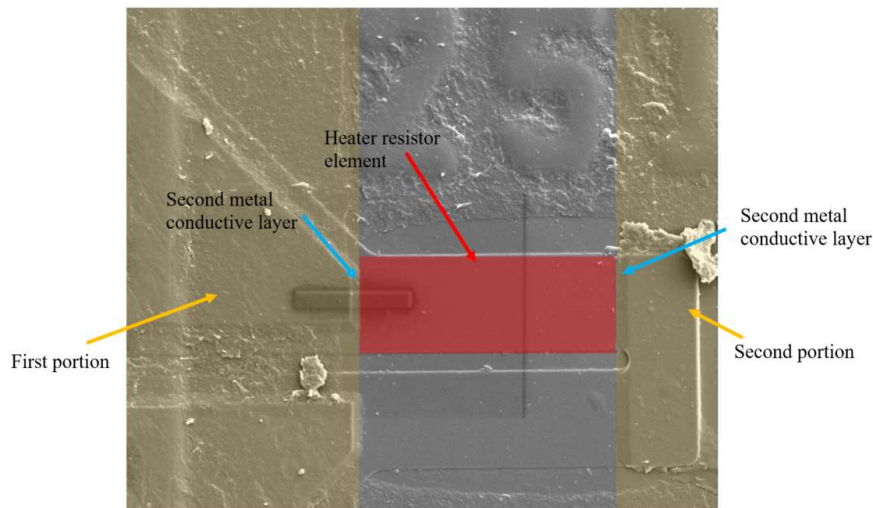
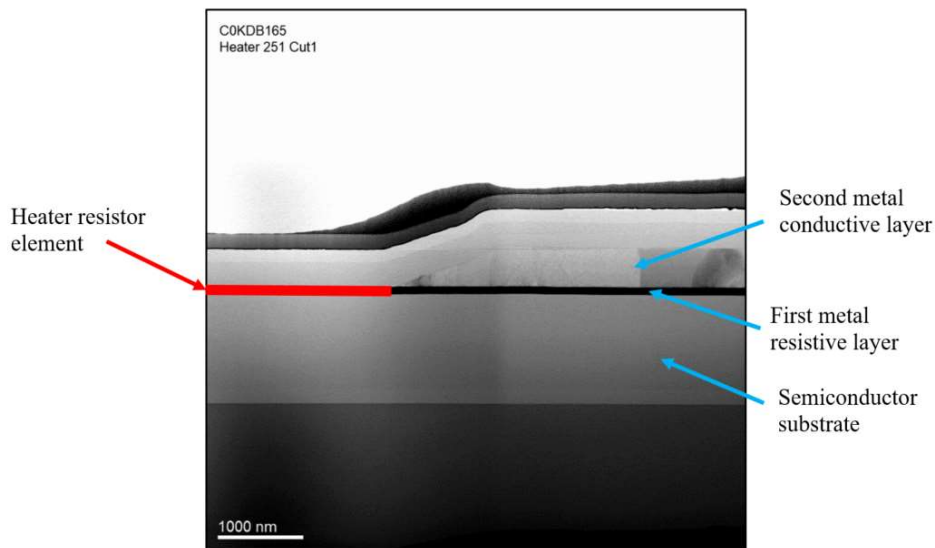

162. The HP 75XL has a passivation layer having a first thickness. On information and belief, the passivation layer is deposited and etched on the second metal conductive layer and heater resistor element and the first thickness is defined by a deposition process alone. The HP 75XL has a cavitation layer adjacent the passivation layer overlying the heater resistor element. On information and belief, the cavitation layer is deposited and etched.

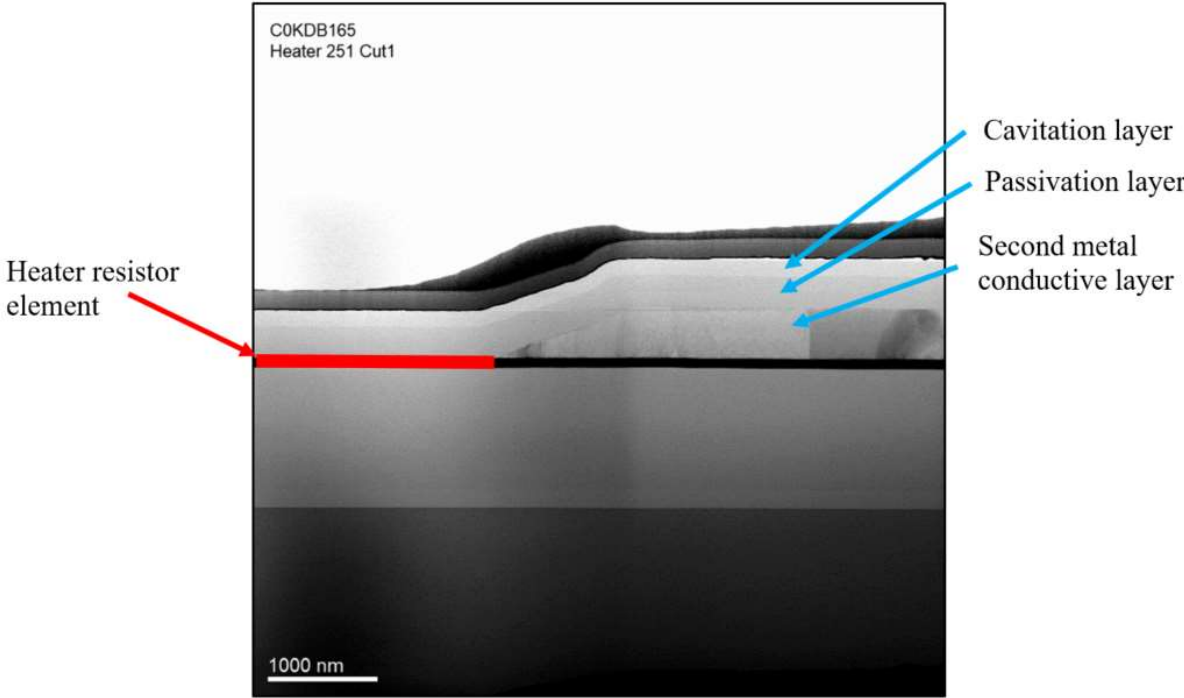

163. On information and belief, the second metal conductive layer overlying the first portion of the resistive layer is substantially devoid of the passivation layer and cavitation layer. In particular, on information and belief, moving towards the left (on diagram below) of the heater resistor, the passivation and cavitation layers terminate.

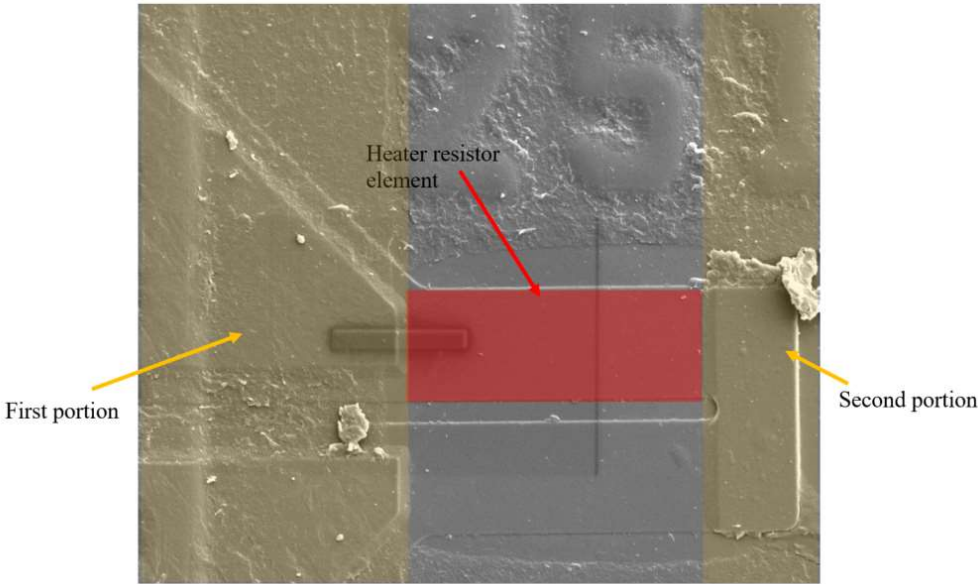

164. The HP 75XL has a dielectric layer overlying the first portion of the resistive layer. The dielectric layer has a second thickness. On information and belief, the dielectric layer is deposited and etched.

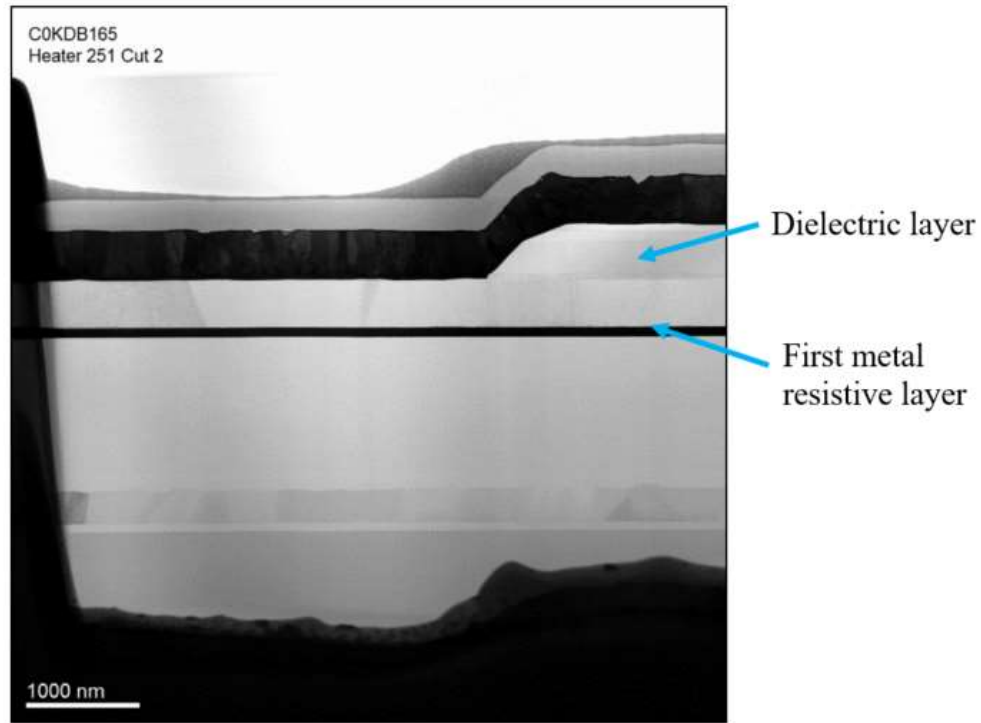

165. The HP 75XL has an electrical conduit via etched in the dielectric layer.

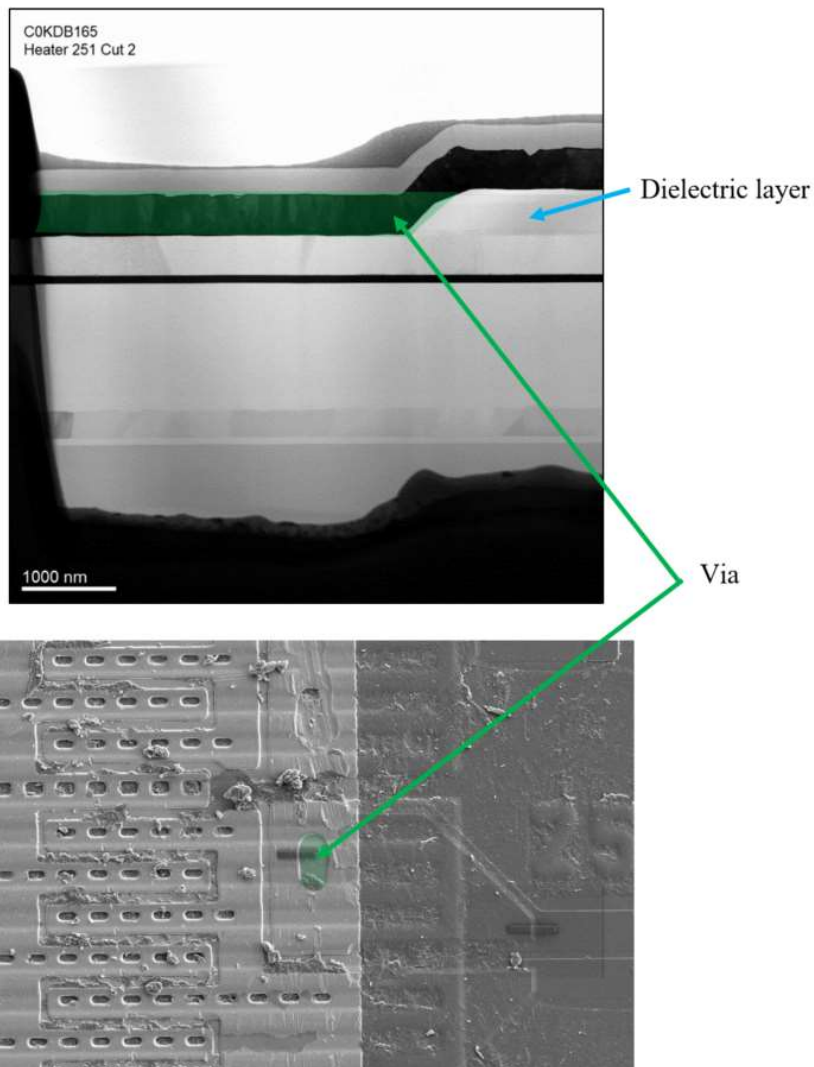

166. The HP 75XL has a third metal conductive layer deposited on the dielectric layer and in the via for electrical contact with the second metal conductive layer. On information and belief, the third metal conductive layer is deposited and etched.

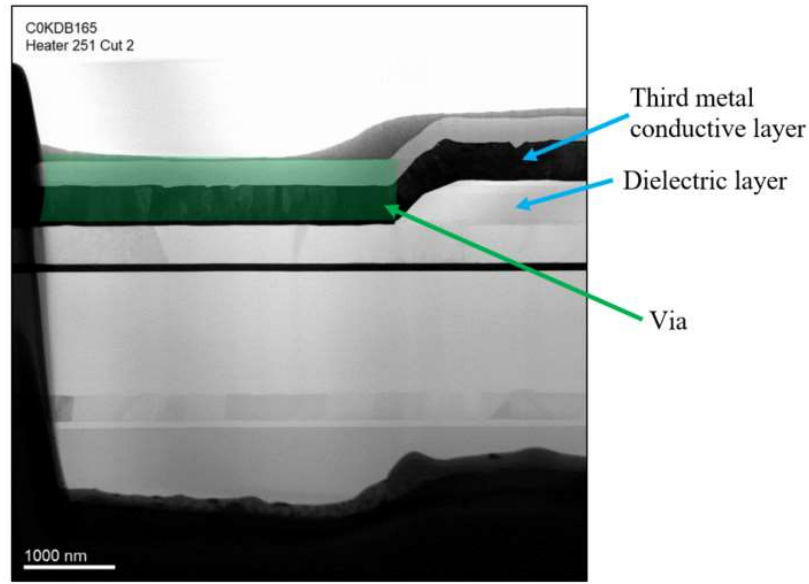

167. On information and belief, the semiconductor substrate of the HP 75XL comprises NMOS transistors.

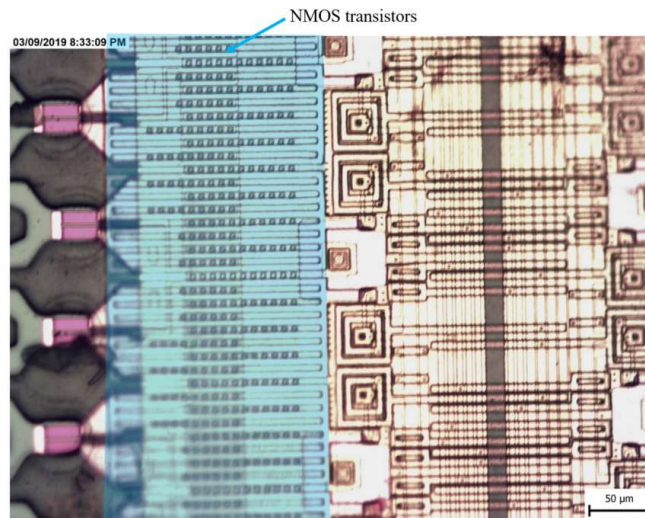

168. The HP 75XL has an inkjet printhead that includes the heater chip of claim 1.

169. On information and belief, HP has been on notice of the '575 Patent at least as early as the filing and service of the Complaint in this action.

170. On information and belief, at least since its post-filing knowledge of the '575 patent, HP knowingly encourages, and continues to encourage, customers and resellers to directly infringe one or more claims of the '575 patent, including by HP's actions that include, without limitation, instructing and encouraging customers to use (and resellers to use, sell and offer to sell) HP inkjet printers and ink cartridges through HP's user guides/manuals, advertisement, promotional materials and instructions.

171. On information and belief, at least since its post-filing knowledge of the '575 patent, HP knows that the acts HP induced customers and resellers to take constitute patent infringement and HP's encouraging acts result in direct infringement by customers and resellers.

172. On information and belief, HP instructs and continues to instruct customers and resellers to setup, use and troubleshoot HP inkjet printers and ink cartridges including, without limitation, on HP's website which provides support on setting up and/or using these products.

173. On information and belief, HP's customers directly infringe at least claims 1, 4 and 6 of the '575 patent through their setup and use of HP inkjet printers and ink cartridges.

174. On information and belief, HP's resellers directly infringe at least claims 1, 4 and 6 of the '575 patent through their setup, use, sale and offer for sale of HP inkjet printers and ink cartridges.

175. On information and belief, HP is in violation of 35 U.S.C. § 271(b) and has been, at least since its post-filing knowledge of the '575 patent, indirectly infringing and



continues to indirectly infringe at least claims 1, 4 and 6 of the '575 patent by knowingly and specifically intending to induce infringement by others (including, without limitation, HP's customers and resellers) and possessing specific intent to encourage infringement by HP's customers and resellers. The heater chip of HP ink cartridges is specifically configured according to the claims of the '575 patent, is a material part of the invention and does not have substantial non-infringing uses.

176. Slingshot has been damaged by the direct and/or indirect infringement of HP and is suffering and will continue to suffer irreparable harm and damages as a result of this infringement.

**Count V - Infringement of United States Patent No. 7,018,012**

177. The allegations set forth above are re-alleged and incorporated by reference as if they were set forth fully here.

178. HP makes, uses, sells, offers to sell and/or imports inkjet printers and ink cartridges in the United States that infringe (literally and/or under the doctrine of equivalents) at least claims 1, 2, 5, 6 and 11 of the '012 patent. HP commits acts of patent infringement through the manufacture, use, sale, offer for sale and/or importation of at least the following products:

**Inkjet printers** including, without limitation, HP ENVY 5540, 5541, 5542, 5543, 5544, 5545, 5547, 5548, 5549, 5640, 5642, 5643, 5644, 5660, 5661, 5663, 5664, 5665, 7640, 7643, 7644, 7645; HP OfficeJet 200, 250, 258, 5740, 5741, 5742, 5743, 5744, 5745, 5746, 8040; ENVY Photo 6220, 6222, 6230, 6232, 6234, 6252, 6255, 7120, 7130, 7134, 7155, 7164, 7820, 7822, 7830, 7855, 7858, 7864; HP DeskJet D4260, D4263,

D4268, D4360, D4363, D4368; HP OfficeJet J5725, J5730, J5735, J5738, J5740, J5750, J5780, J5783, J5785, J5788, J5790, J6410, J6415 All-in-One, J6424.

**Ink cartridges/printheads** including, without limitation, HP 62XL tricolor, HP 64 tricolor, HP 64XL tricolor, HP 75XL tricolor (setup and non-setup/replacement cartridges).

179. On information and belief, inkjet printers listed above are sold with setup ink cartridges that have a limited supply of ink. On information and belief, setup ink cartridges are used for initial configuration/calibration and/or proper operation of the printer. On information and belief, for inkjet printers that come with setup ink cartridges, a user must use a setup ink cartridge the first time that the printer is turned on/initialized. Setup ink cartridges are marked with the word "Setup" and, in some cases, identify non-setup/replacement ink cartridge(s) that should be used with an inkjet printer once the ink in the setup ink cartridge has been depleted. Exemplary setup ink cartridges are shown below.



180. Setup ink cartridges are structurally similar to non-setup/replacement ink cartridges. On information and belief, once a setup ink cartridge has been used to configure/calibrate a printer, another setup ink cartridge cannot subsequently be used

in the printer. After the ink in the setup ink cartridge is depleted, customers must buy and use non-setup/replacement cartridges to continue to use the printer.

181. The ink cartridges include an inkjet printhead. The ink cartridges can be purchased separately from the inkjet printer. The ink cartridges are necessary for the operation of the inkjet printers and vice versa.

182. On information and belief, with regard to the claim elements of the '012 patent, the HP 62XL tri-color, HP 64 tri-color and HP 64XL tri-color are structurally similar to each other. Infringement of the '012 patent by the ink cartridges and associated inkjet printers is demonstrated below using the HP 64XL tri-color as an example.

183. HP makes, uses, sells, offers to sell and/or imports a semiconductor substrate for a microfluid ejection head (e.g., HP 64XL tri-color ("HP 64XL")).



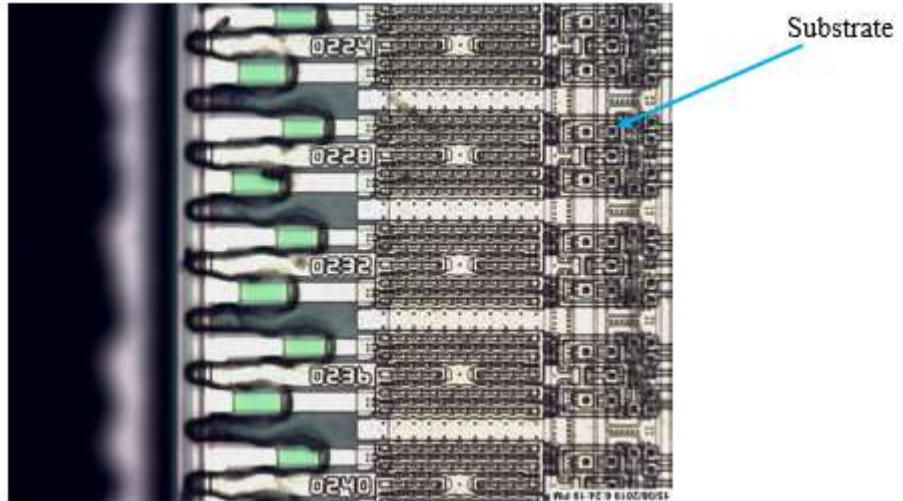

184. The substrate of the HP 64XL has a plurality of fluid ejection actuators disposed on the substrate. The substrate of the HP 64XL has a plurality of driver transistors disposed on the substrate for driving the plurality of fluid ejection actuators.

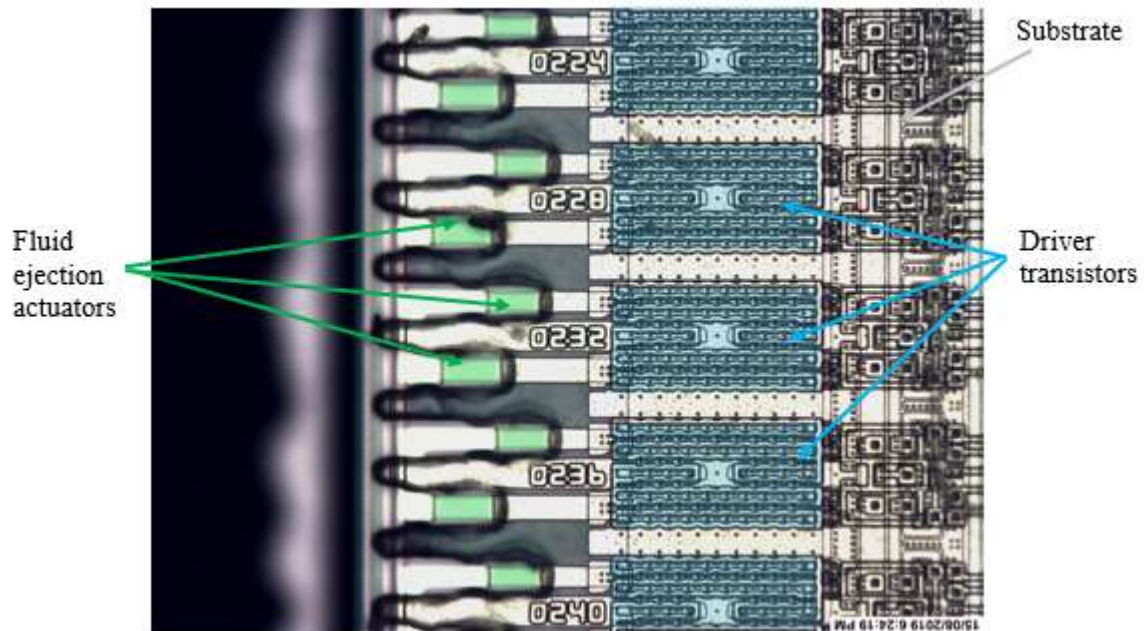

185. Each of the driver transistors having an active area of approximately  $4107 \mu\text{m}^2$  - from about 1000 to less than about  $15,000 \mu\text{m}^2$

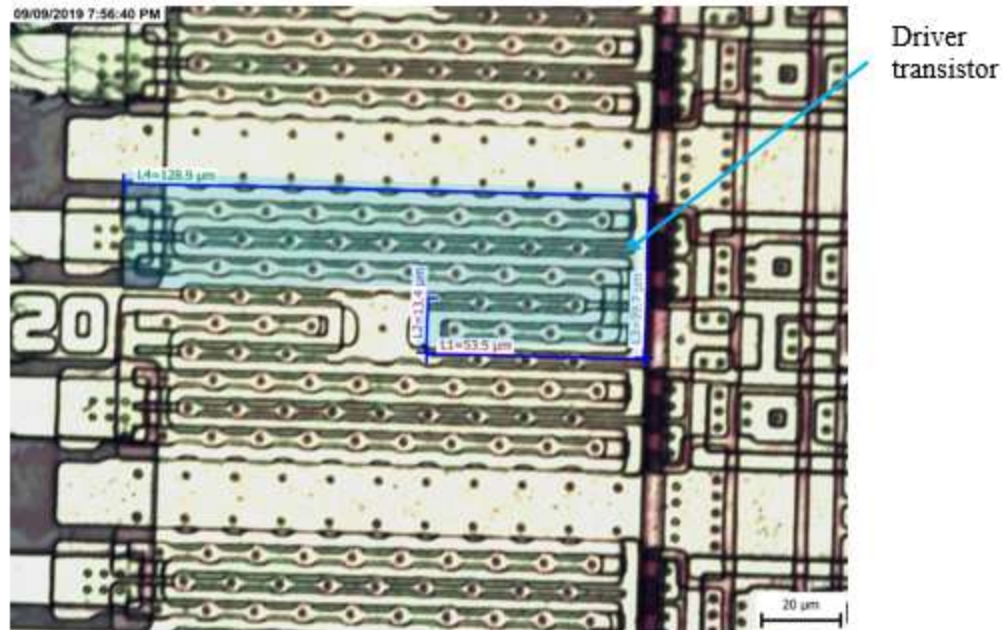

186. The substrate of the HP 64XL has a plurality of logic circuits including at least one logic transistor. The logic circuits are coupled to the driver transistors.

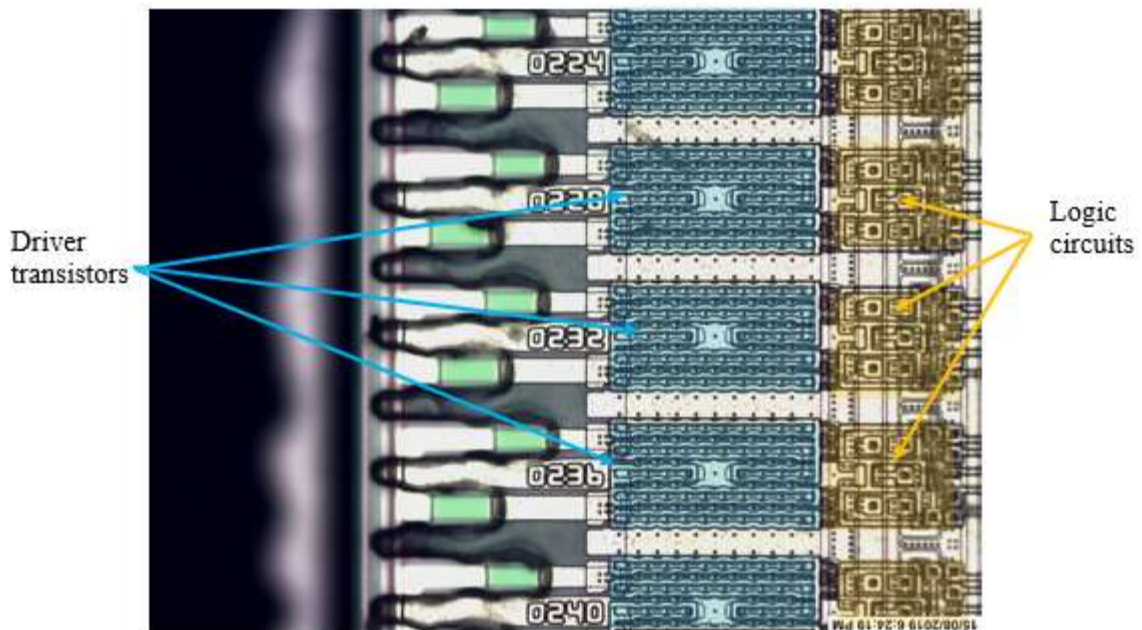

187. On information and belief, each of the driver and logic transistors include a high density array of MOS transistors. On information and belief, at least the logic

transistors have a gate length of from about 0.1 to less than about 3 microns because MOS logic is made with gates of this length.

188. The fluid ejection actuators of the HP 64XL have heater resistors.

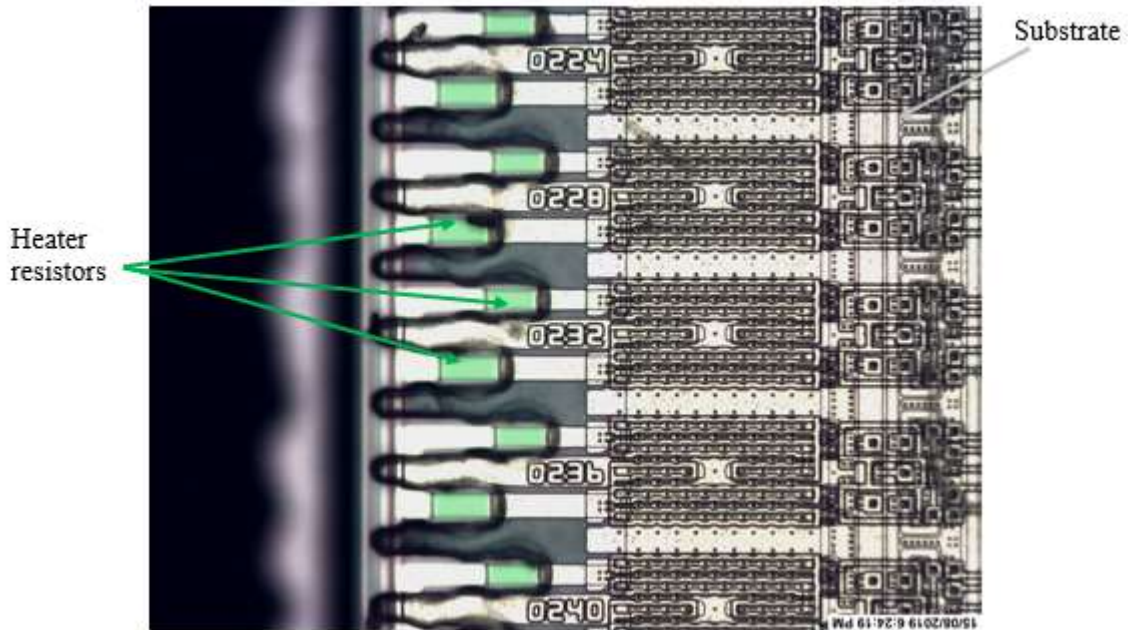

189. The driver transistors of the HP 64XL have an active area width of 128.9 microns - i.e., from about 100 to less than about 400 microns.

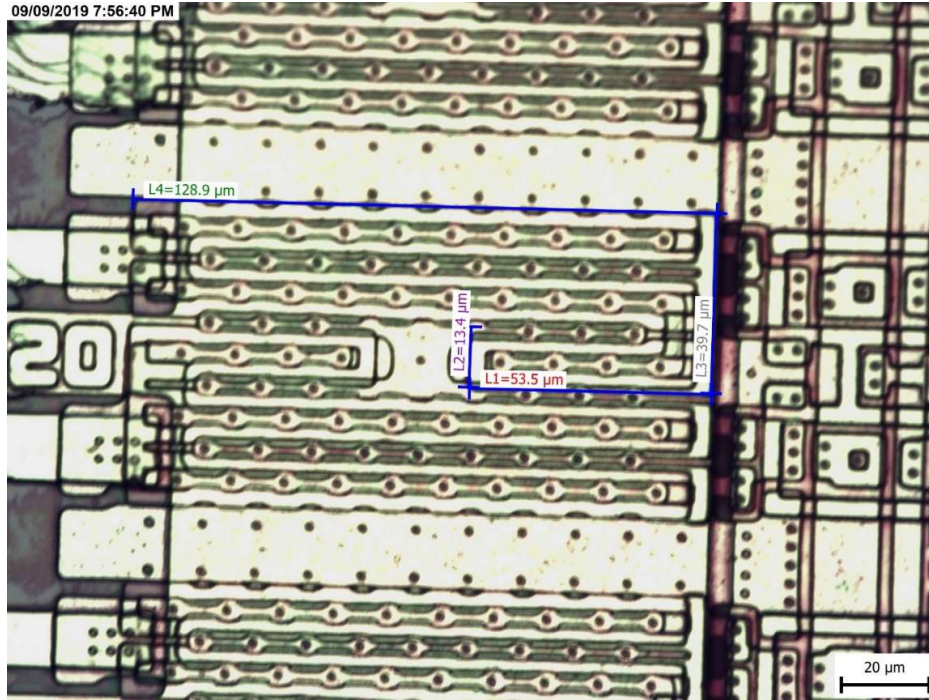

190. The logic circuits of the HP 64XL are configured to select a gate of the driver transistors for driving the ejection actuators.

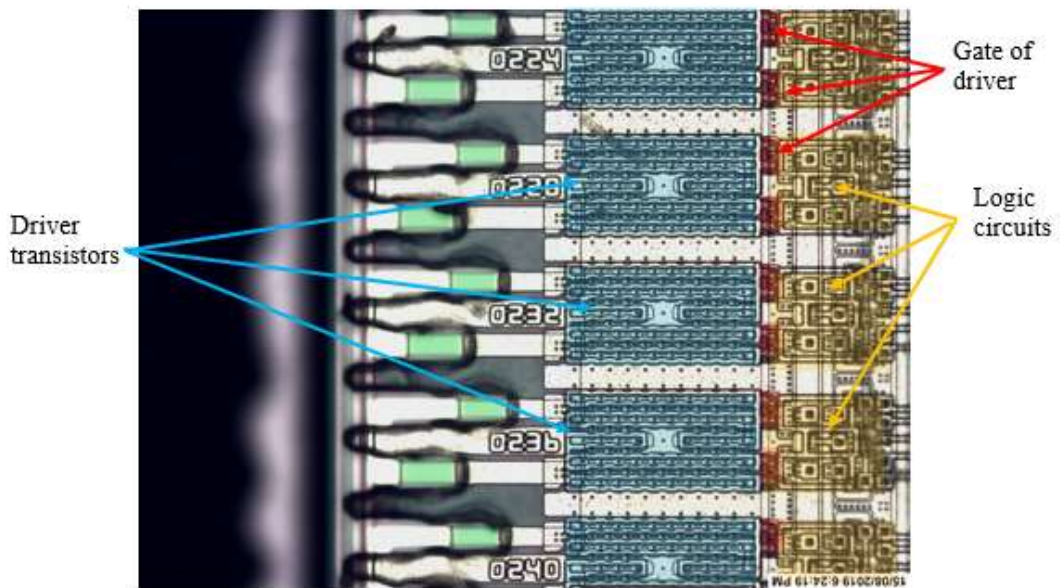

191. The HP 64XL has a printhead containing the semiconductor substrate of claim 1. The HP 64XL is used in an inkjet printer.

192. On information and belief, HP has been on notice of the '012 patent at least as early as the filing and service of the Complaint in this action.

193. On information and belief, at least since its post-filing knowledge of the '012 patent, HP knowingly encourages, and continues to encourage, customers and resellers to directly infringe one or more claims of the '012 patent, including by HP's actions that include, without limitation, instructing and encouraging customers to use (and resellers to use, sell and offer to sell) HP inkjet printers and ink cartridges through HP's user guides/manuals, advertisement, promotional materials and instructions.

194. On information and belief, at least since its post-filing knowledge of the '012 patent, HP knows that the acts HP induced customers and resellers to take constitute patent infringement and HP's encouraging acts result in direct infringement by customers and resellers.

195. On information and belief, HP instructs and continues to instruct customers and resellers to setup, use and troubleshoot HP inkjet printers and ink cartridges including, without limitation, on HP's website which provides support on setting up and/or using these products.

196. On information and belief, HP's customers directly infringe at least claims 1, 2, 5, 6 and 11 of the '012 patent through their setup and use of HP inkjet printers and ink cartridges.

197. On information and belief, HP's resellers directly infringe at least claims 1, 2, 5, 6 and 11 of the '012 patent through their setup, use, sale and offer for sale of HP inkjet printers and ink cartridges.



198. On information and belief, HP is in violation of 35 U.S.C. § 271(b) and has been, at least since its post-filing knowledge of the '012 patent, indirectly infringing and continues to indirectly infringe at least claims 1, 2, 5, 6 and 11 of the '012 patent by knowingly and specifically intending to induce infringement by others (including, without limitation, HP's customers and resellers) and possessing specific intent to encourage infringement by HP's customers and resellers. The semiconductor substrate of HP ink cartridges is specifically configured according to the claims of the '012 patent, is a material part of the invention and does not have substantial non-infringing uses.

199. Slingshot has been damaged by the direct and/or indirect infringement of HP and is suffering and will continue to suffer irreparable harm and damages as a result of this infringement.

**Count VI - Infringement of United States Patent No. 7,195,341**

200. The allegations set forth above are re-alleged and incorporated by reference as if they were set forth fully here.

201. HP makes, uses, sells, offers to sell and/or imports inkjet printers and ink cartridges in the United States that infringe (literally and/or under the doctrine of equivalents) at least claims 1, 2, 3 and 8 of the '341 patent. HP commits acts of patent infringement through the manufacture, use, sale, offer for sale and/or importation of at least the following products:

**Inkjet printers** including, without limitation, HP ENVY 6220, 6222, 6230, 6232, 6234, 6252, 6255, 7120, 7130, 7134, 7155, 7064, 7820, 7822, 7830, 7855, 7858, 7864.

**Ink cartridges/printheads** including, without limitation, HP 64XL tricolor.

202. On information and belief, inkjet printers listed above are sold with setup ink cartridges that have a limited supply of ink. On information and belief, setup ink cartridges are used for initial configuration/calibration and/or proper operation of the printer. On information and belief, for inkjet printers that come with setup ink cartridges, a user must use a setup ink cartridge the first time that the printer is turned on/initialized. Setup ink cartridges are marked with the word "Setup" and, in some cases, identify non-setup/replacement ink cartridge(s) that should be used with an inkjet printer once the ink in the setup ink cartridge has been depleted. An exemplary setup ink cartridge is shown below.



203. Setup ink cartridges are structurally similar to non-setup/replacement ink cartridges. On information and belief, once a setup ink cartridge has been used to configure/calibrate a printer, another setup ink cartridge cannot subsequently be used in the printer. After the ink in the setup ink cartridge is depleted, customers must buy and use non-setup/replacement cartridges to continue to use the printer.

204. The ink cartridges include an inkjet printhead. The ink cartridges can be purchased separately from the inkjet printer. The ink cartridges are necessary for the operation of the inkjet printers and vice versa.

205. Infringement of the '341 patent by the ink cartridges and associated inkjet printers is demonstrated below using the HP 64XL tri-color as an example.

206. HP makes, uses, sells, offers to sell and/or imports a semiconductor substrate for a micro-fluid ejection device (e.g., HP 64XL tri-color ("HP 64XL")).

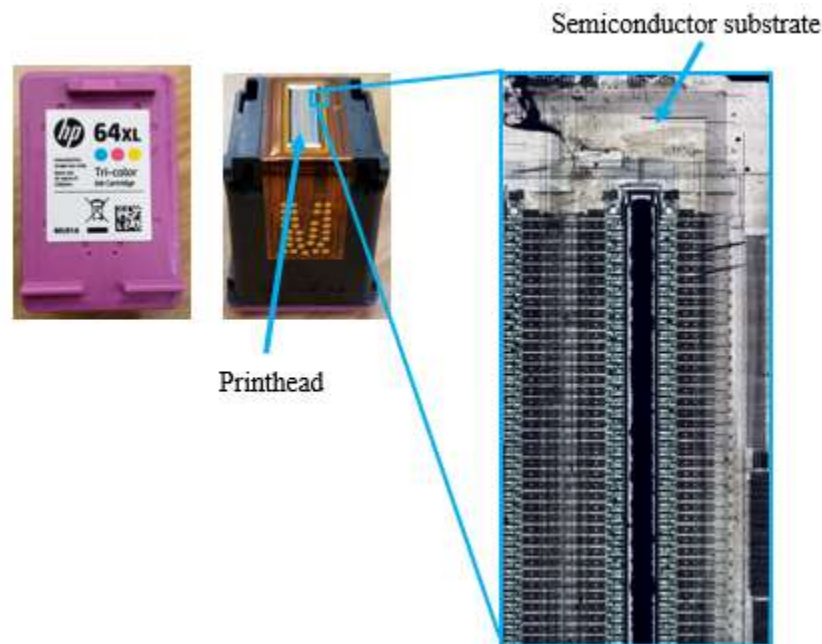

207. The substrate of the HP 64XL has a plurality of micro-fluid ejection actuators (heaters) disposed in a columnar array adjacent a fluid supply slot (via) in the semiconductor substrate.

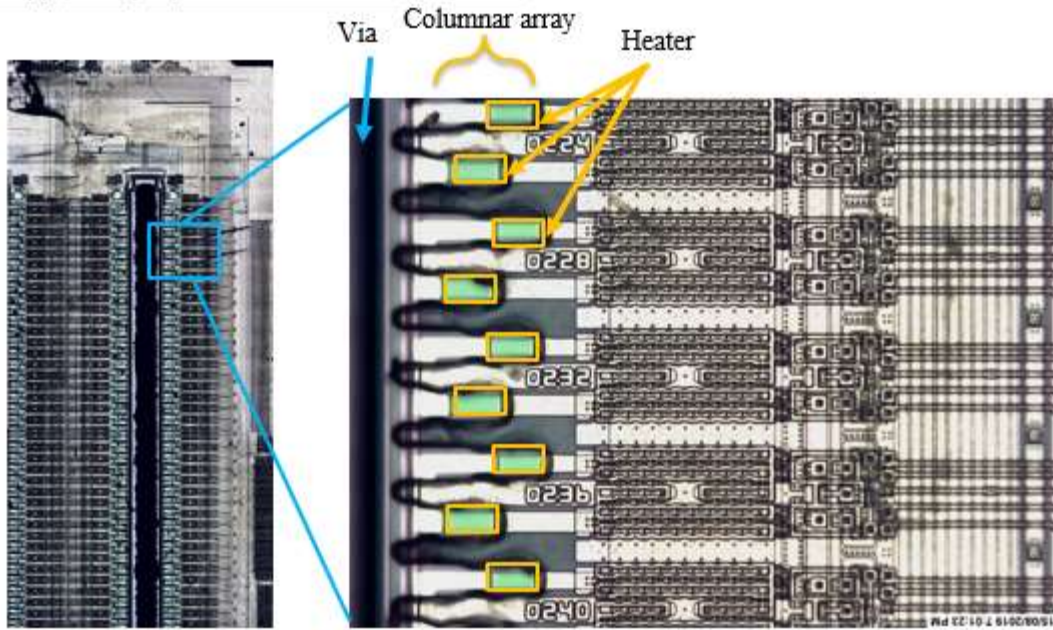

208. The substrate of the HP 64XL has a plurality of power transistors disposed in a columnar array adjacent the ejection actuators and connected through a first metal conductor layer to the ejection actuators. The columnar array of power transistors occupying a power transistor active area of the substrate.

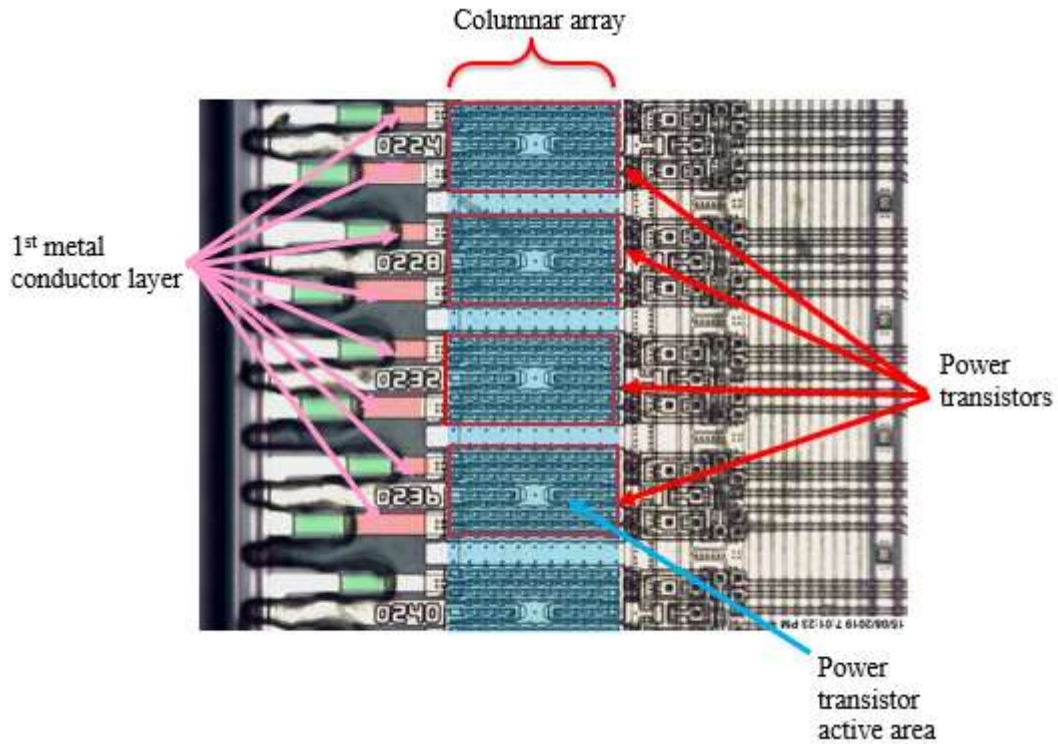

209. The substrate of the HP 64XL has a columnar array of logic circuits disposed adjacent the columnar array of power transistors and connected through a polysilicon conductor layer to the power transistors. The columnar array of logic circuits occupying a logic circuit area of the substrate.

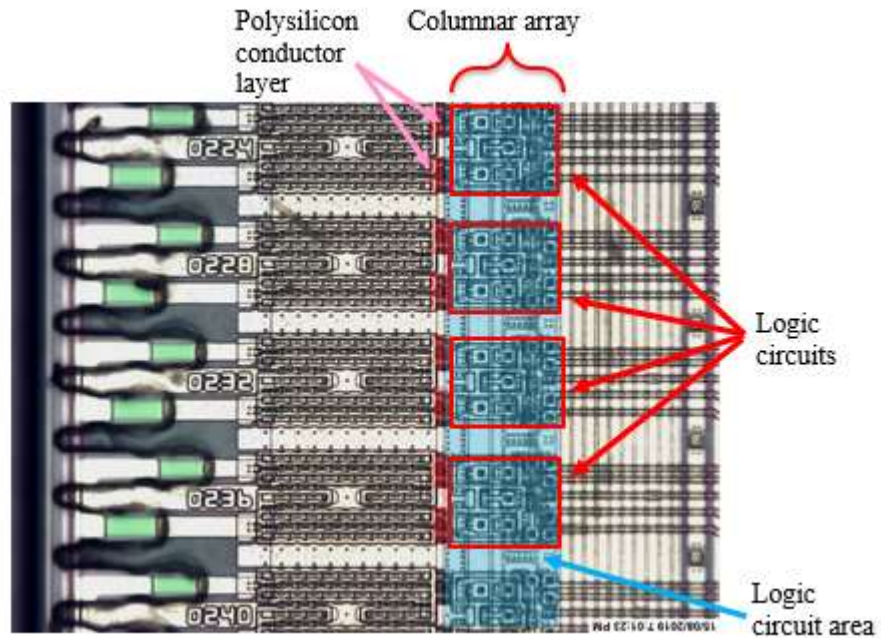

210. The substrate of the HP 64XL has a power conductor for the ejection actuators routed in a second metal conductor layer disposed in overlapping relationship with at least a portion of the power transistor active area of the substrate.

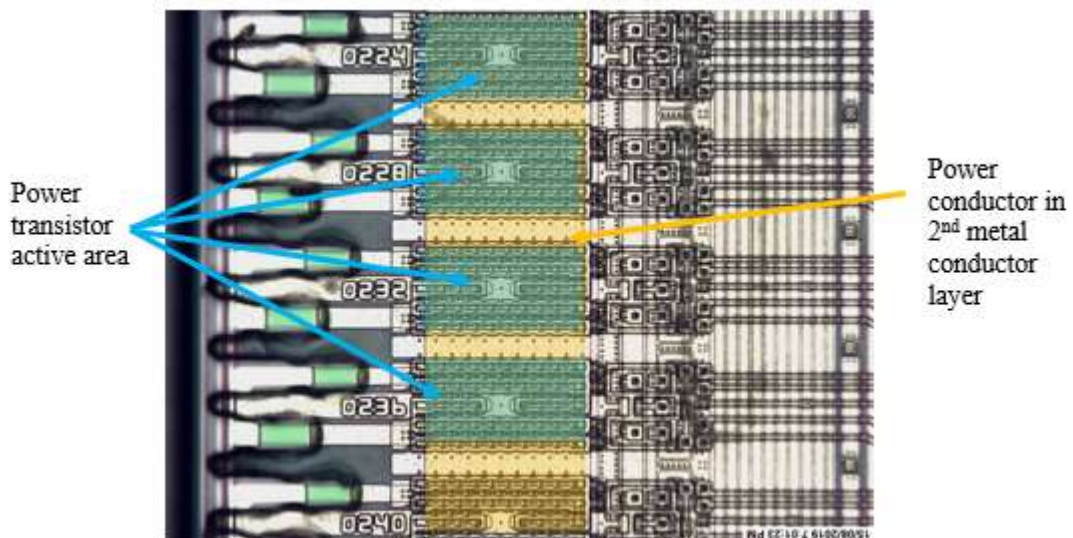

211. The substrate of the HP 64XL has a ground conductor for the ejection actuators routed in the second metal conductor layer disposed in overlapping relationship with at least a portion of the logic circuit area of the substrate.

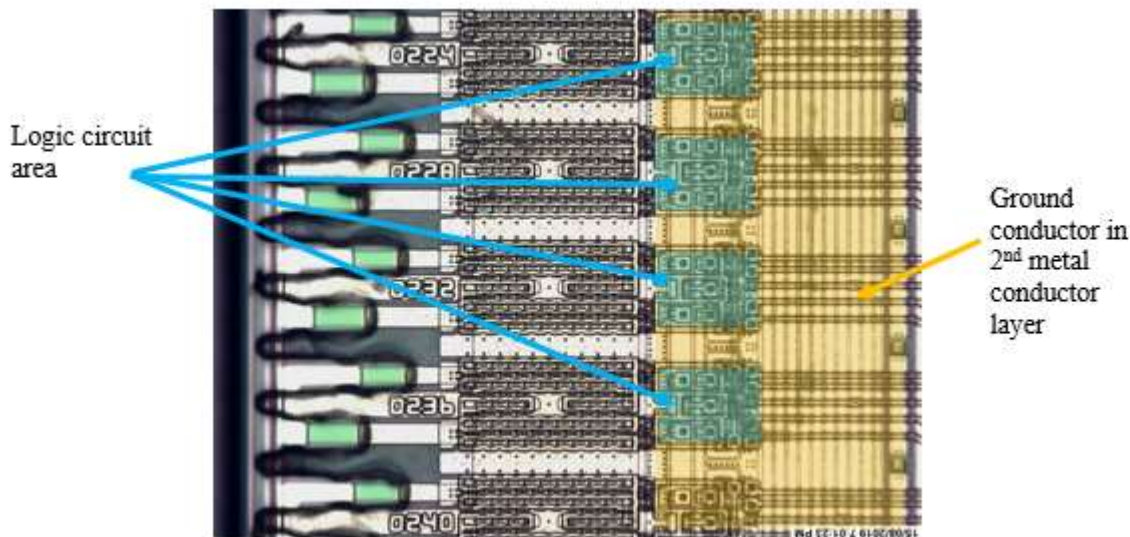

212. The fluid ejection actuators in the HP 64XL comprise heater resistors. The HP 64XL is used, for example, with the HP ENVY Photo 6255 All-in-One printer which is a “Thermal Inkjet.”

HP ENVY Photo 6255 All-in-One Printer Specifications Table			
Functions / Multitasking Supported	Print, Scan, Copy, Web, Photo/ Yes	What's in the box	K7G18A HP ENVY Photo 6255 All-in-One Printer; HP 64 Setup Black Instant Ink Ready Cartridges (~185 pages); HP 64 Setup Tri-color Instant Ink Ready Cartridges (~120 pages); No CD Flyer; Ink Caution Flyer; Power Cord; Setup card; Getting started guide; Instant Ink Flyer; Media Pack.
Print Speed <sup>4</sup>	Black (ISO): Up to 12 ppm; Color (ISO): Up to 8 ppm First Page Out Black: As fast as 17 sec; First Page Out Color: As fast as 20 sec	Replacement Cartridges <sup>2</sup>	HP 64 Black Ink Cartridge (~200 pages); HP 64 Tri-color Ink Cartridge (~165 pages); HP 64XL Black Ink Cartridge (~600 pages); HP 64XL Tri-color Ink Cartridge (~415 pages). Average based on ISO/IEC 24711 or HP testing methodology and continuous printing. Actual yield varies considerably based on content of printed pages and other factors. For details see <a href="http://www.hp.com/go/learnaboutsupplies">http://www.hp.com/go/learnaboutsupplies</a>
Print Resolution	Black (best): Up to 1200 x 1200 rendered dpi (when printing from a computer); Color (best): Up to 4800 x 1200 optimized dpi color (when printing from a computer on selected HP photo papers and Print in Max dpi)	Instant Ink eligible	Instant Ink Ready* / Save up to 50% on ink. For more information visit <a href="http://hpinstantink.com">hpinstantink.com</a>
Print Technology	HP Thermal Inkjet		
Print Cartridges Number	2: 1 black, 1 Tri-color (cyan, magenta, yellow)		
Borderless Printing	Yes (up to 8.5 x 11 in, 216 x 297 mm)		

HP ENVY Photo 6255 All-in-One Printer Datasheet (Apr. 2019)

213. The semiconductor substrate of the HP 64XL contains three fluid supply slots (vias) and associated ejection actuators, power transistors, logic circuits and conductors.

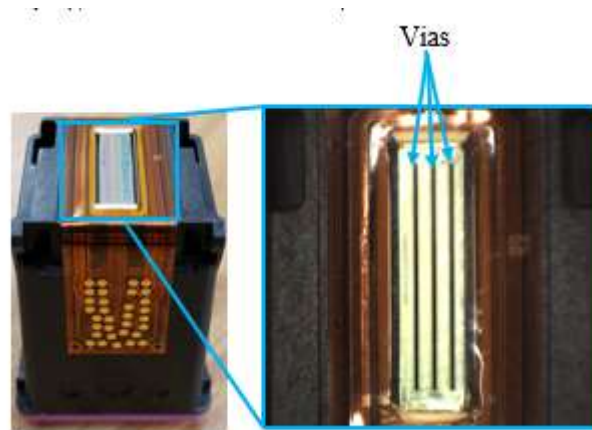

214. The micro-fluid ejection head (printhead) of the HP 64XL includes the semiconductor substrate of claim 1.

215. On information and belief, HP has been on notice of the '341 patent at least as early as the filing and service of the Complaint in this action.

216. On information and belief, at least since its post-filing knowledge of the '341 patent, HP knowingly encourages, and continues to encourage, customers and resellers to directly infringe one or more claims of the '341 patent, including by HP's actions that include, without limitation, instructing and encouraging customers to use (and resellers to use, sell and offer to sell) HP inkjet printers and ink cartridges through HP's user guides/manuals, advertisement, promotional materials and instructions.

217. On information and belief, at least since its post-filing knowledge of the '341 patent, HP knows that the acts HP induced customers and resellers to take constitute patent infringement and HP's encouraging acts result in direct infringement by customers and resellers.

218. On information and belief, HP instructs and continues to instruct customers and resellers to setup, use and troubleshoot HP inkjet printers and ink



cartridges including, without limitation, on HP's website which provides support on setting up and/or using these products.

219. On information and belief, HP's customers directly infringe at least claims 1, 2, 3 and 8 of the '341 patent through their setup and use of HP inkjet printers and ink cartridges.

220. On information and belief, HP's resellers directly infringe at least claims 1, 2, 3 and 8 of the '341 patent through their setup, use, sale and offer for sale of HP inkjet printers and ink cartridges.

221. On information and belief, HP is in violation of 35 U.S.C. § 271(b) and has been, at least since its post-filing knowledge of the '341 patent, indirectly infringing and continues to indirectly infringe at least claims 1, 2, 3 and 8 of the '341 patent by knowingly and specifically intending to induce infringement by others (including, without limitation, HP's customers and resellers) and possessing specific intent to encourage infringement by HP's customers and resellers. The semiconductor substrate of HP ink cartridges is specifically configured according to the claims of the '341 patent, is a material part of the invention and does not have substantial non-infringing uses.

222. Slingshot has been damaged by the direct and/or indirect infringement of HP and is suffering and will continue to suffer irreparable harm and damages as a result of this infringement.

**Count VII - Infringement of United States Patent No. 7,290,864**

223. The allegations set forth above are re-alleged and incorporated by reference as if they were set forth fully here.

224. HP makes, uses, sells, offers to sell and/or imports inkjet printers and ink cartridges in the United States that infringe (literally and/or under the doctrine of equivalents) at least claims 1, 3, 5 and 6 of the '864 patent. HP commits acts of patent infringement through the manufacture, use, sale, offer for sale and/or importation of at least the following products:

**Inkjet printers** including, without limitation, HP ENVY 6220, 6222, 6230, 6232, 6234, 6252, 6255, 7120, 7130, 7134, 7155, 7064, 7820, 7822, 7830, 7855, 7858, 7864; HP DeskJet D4260, D4263, D4360, D4363, D4368; HP OfficeJet J5725, J5730, J5735, J5738, J5740, J5750, J5780, J5783, J5785, J5788, J5790, J6410, J6415 All-in-One, J6424.  
**Ink cartridges/printheads** including, without limitation, HP 64 tricolor, HP 64XL tricolor, HP 75XL tricolor (setup and non-setup/replacement cartridges).

225. On information and belief, inkjet printers listed above are sold with setup ink cartridges that have a limited supply of ink. On information and belief, setup ink cartridges are used for initial configuration/calibration and/or proper operation of the printer. On information and belief, for inkjet printers that come with setup ink cartridges, a user must use a setup ink cartridge the first time that the printer is turned on/initialized. Setup ink cartridges are marked with the word "Setup" and, in some cases, identify non-setup/replacement ink cartridge(s) that should be used with an inkjet printer once the ink in the setup ink cartridge has been depleted. An exemplary setup ink cartridge is shown below.



226. Setup ink cartridges are structurally similar to non-setup/replacement ink cartridges. On information and belief, once a setup ink cartridge has been used to configure/calibrate a printer, another setup ink cartridge cannot subsequently be used in the printer. After the ink in the setup ink cartridge is depleted, customers must buy and use non-setup/replacement cartridges to continue to use the printer.

227. The ink cartridges include an inkjet printhead. The ink cartridges can be purchased separately from the inkjet printer. The ink cartridges are necessary for the operation of the inkjet printers and vice versa.

228. On information and belief, with regard to the claim elements of the '864 patent, the HP 64 tricolor, HP 64XL tricolor and HP 75XL tricolor are structurally similar to each other. Infringement of the '864 patent by the ink cartridges and associated inkjet printers is demonstrated below using the HP 64XL tricolor as an example.

229. HP makes, uses, sells, offers to sell and/or imports ink cartridges (e.g., HP 64XL tricolor (“HP 64XL”)) which include a heater chip for use in a printing device (e.g., inkjet printer).



230. The HP 64XL has an ink via.



231. The HP 64XL has a first heater array adjacent at least a portion of one side of the ink via.



232. The HP 64XL has a second heater array adjacent at least a portion of another side of the ink via.

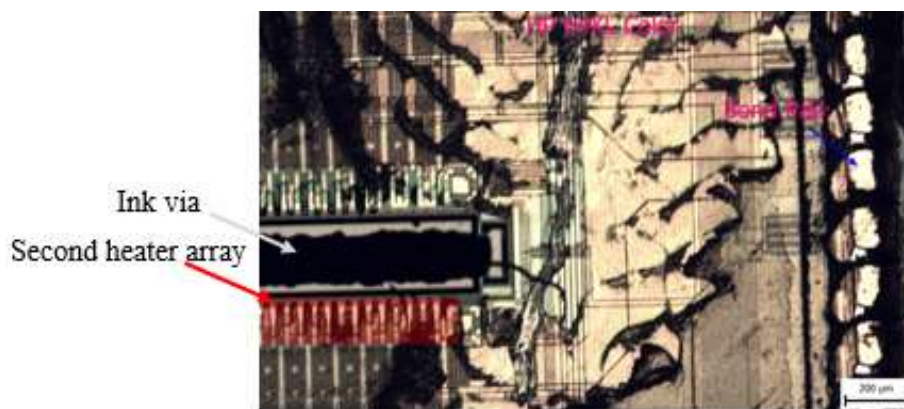

233. The HP 64XL has a bondpad that supplies power to at least a portion of the first heater array and to at least a portion of the second heater array. In particular, a trace (shown in green below) provides power from the bondpad to the first and second heater array.

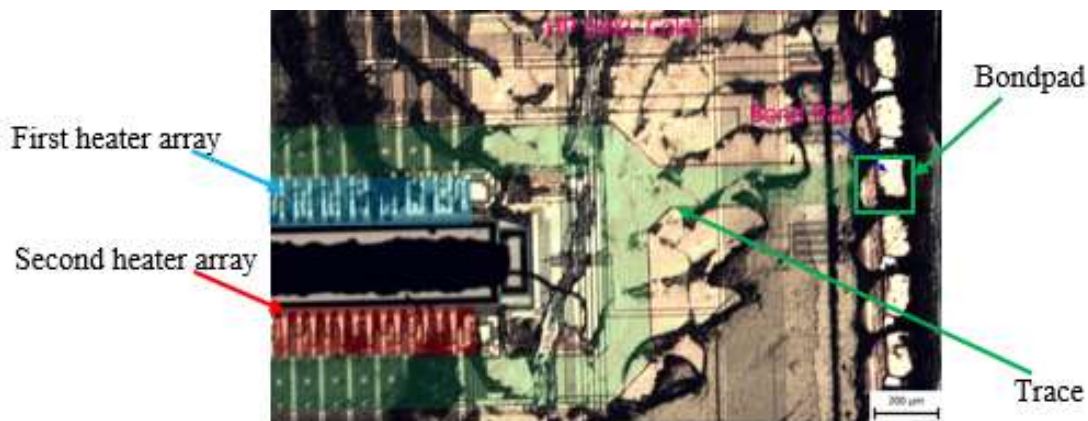

234. The bondpad of the HP 64XL supplies power to the first heater array and the second heater array portions by power traces physically separated proximal to the bondpad.



235. The bondpad of the HP 64XL supplies power to the first heater array and the second heater array by at least one power trace. The first heater array and the second heater array of the HP 64XL each include a plurality of thin film resistors.

236. On information and belief, HP has been on notice of the '864 patent at least as early as the filing and service of the Complaint in this action.

237. On information and belief, at least since its post-filing knowledge of the '864 patent, HP knowingly encourages, and continues to encourage, customers and resellers to directly infringe one or more claims of the '864 patent, including by HP's actions that include, without limitation, instructing and encouraging customers to use (and resellers to use, sell and offer to sell) HP inkjet printers and ink cartridges through HP's user guides/manuals, advertisement, promotional materials and instructions.

238. On information and belief, at least since its post-filing knowledge of the '864 patent, HP knows that the acts HP induced customers and resellers to take constitute patent infringement and HP's encouraging acts result in direct infringement by customers and resellers.

239. On information and belief, HP instructs and continues to instruct customers and resellers to setup, use and troubleshoot HP inkjet printers and ink cartridges including, without limitation, on HP's website which provides support on setting up and/or using these products.

240. On information and belief, HP's customers directly infringe at least claims 1, 3, 5 and 6 of the '864 patent through their setup and use of HP inkjet printers and ink cartridges.

241. On information and belief, HP's resellers directly infringe at least claims 1, 3, 5 and 6 of the '864 patent through their setup, use, sale and offer for sale of HP inkjet printers and ink cartridges.

242. On information and belief, HP is in violation of 35 U.S.C. § 271(b) and has been, at least since its post-filing knowledge of the '864 patent, indirectly infringing and

continues to indirectly infringe at least claims 1, 3, 5 and 6 of the '864 patent by knowingly and specifically intending to induce infringement by others (including, without limitation, HP's customers and resellers) and possessing specific intent to encourage infringement by HP's customers and resellers. The heater chip of HP ink cartridges is specifically configured according to the claims of the '864 patent, is a material part of the invention and does not have substantial non-infringing uses.

243. Slingshot has been damaged by the direct and/or indirect infringement of HP and is suffering and will continue to suffer irreparable harm and damages as a result of this infringement.

**Count VIII - Infringement of United States Patent No. 7,410,246**

244. The allegations set forth above are re-alleged and incorporated by reference as if they were set forth fully here.

245. HP makes, uses, sells, offers to sell and/or imports inkjet printers and ink cartridges in the United States that infringe (literally and/or under the doctrine of equivalents) at least claim 24 of the '246B patent. HP commits acts of patent infringement through the manufacture, use, sale, offer for sale and/or importation of at least the following products:

**Inkjet printers** including, without limitation, HP ENVY 6220, 6222, 6230, 6232, 6234, 6252, 6255, 7120, 7130, 7134, 7155, 7064, 7820, 7822, 7830, 7855, 7858, 7864.

**Ink cartridges/printheads** including, without limitation, HP 64XL tricolor.

246. On information and belief, inkjet printers listed above are sold with setup ink cartridges that have a limited supply of ink. On information and belief, setup ink



cartridges are used for initial configuration/calibration and/or proper operation of the printer. On information and belief, for inkjet printers that come with setup ink cartridges, a user must use a setup ink cartridge the first time that the printer is turned on/initialized. Setup ink cartridges are marked with the word "Setup" and, in some cases, identify non-setup/replacement ink cartridge(s) that should be used with an inkjet printer once the ink in the setup ink cartridge has been depleted. An exemplary setup ink cartridge is shown below.



247. Setup ink cartridges are structurally similar to non-setup/replacement ink cartridges. On information and belief, once a setup ink cartridge has been used to configure/calibrate a printer, another setup ink cartridge cannot subsequently be used in the printer. After the ink in the setup ink cartridge is depleted, customers must buy and use non-setup/replacement cartridges to continue to use the printer.

248. The ink cartridges include an inkjet printhead. The ink cartridges can be purchased separately from the inkjet printer. The ink cartridges are necessary for the operation of the inkjet printers and vice versa.

249. Infringement of the '246B patent by the ink cartridges and associated inkjet printers is demonstrated below using the HP 64XL tricolor as an example.

250. HP makes, uses, sells, offers to sell and/or imports a heater chip for an inkjet printhead (printhead of the HP 64XL tricolor (“HP 64XL”)).

251. The heater chip of the HP 64XL has a silicon substrate.

252. The HP 64XL was sectioned using FIB / STEM techniques on the transition between the metal layer and the small heater (shown by the dashed red line).

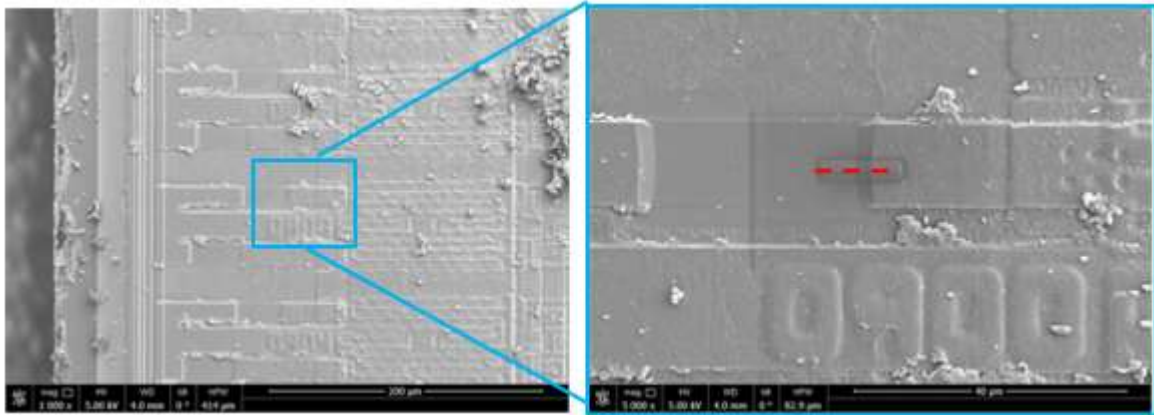

253. The layers from the section are shown below.

254. The heater chip of the HP 64XL has a thermal barrier layer on the substrate. The thermal barrier layer has multiple layers - layer 1 (silicon oxide), layer 2 (silicon nitride) and layer 3 (silicon oxide).

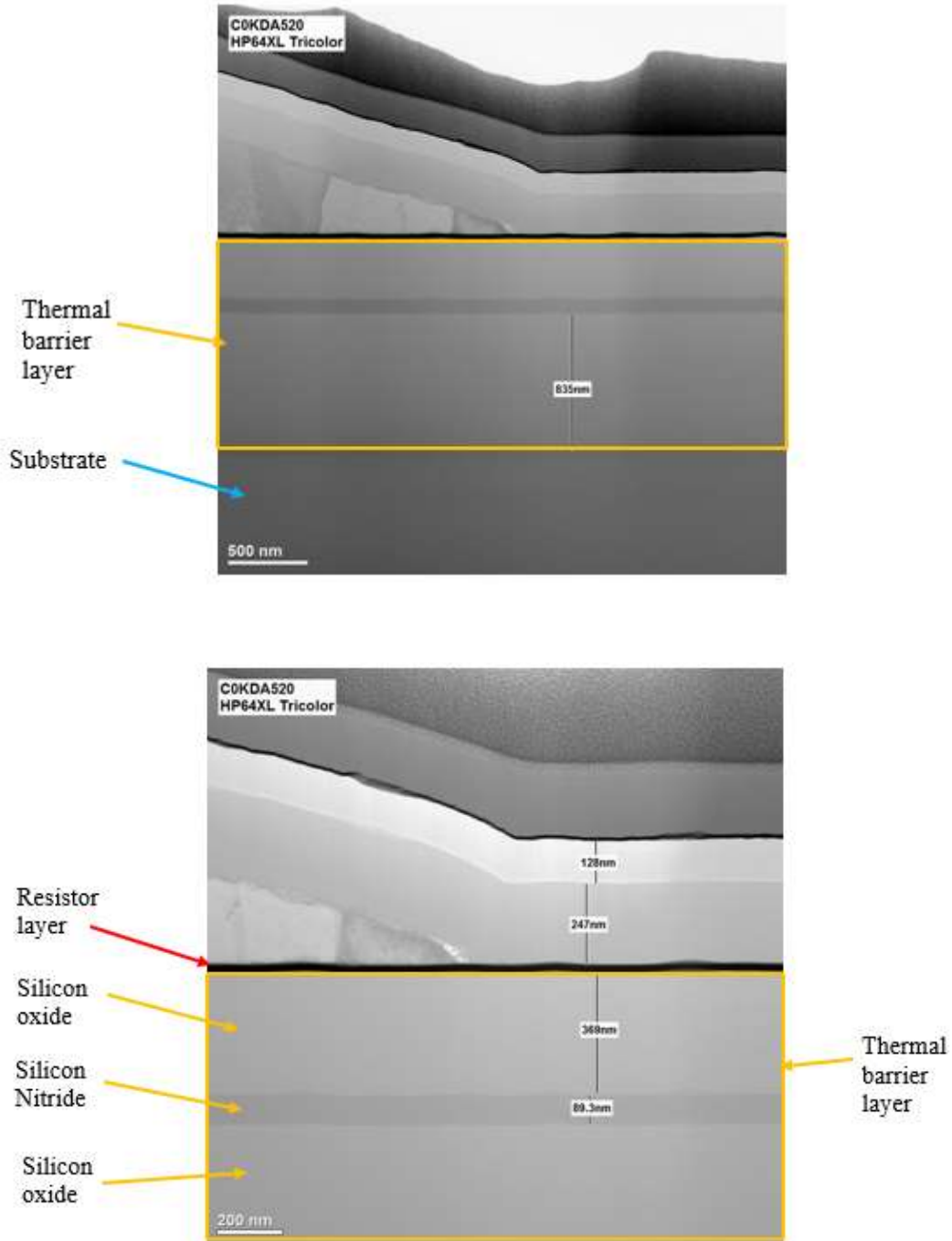

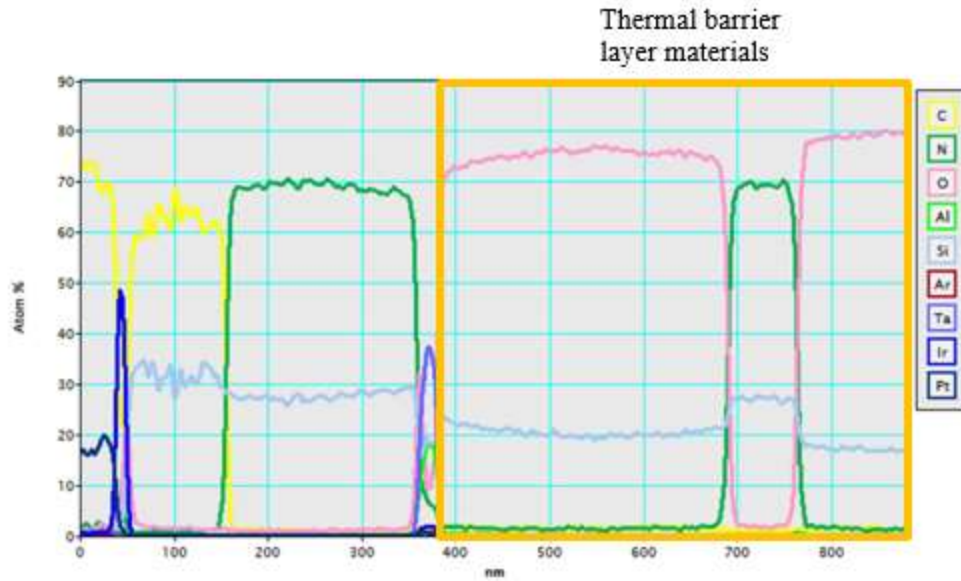

255. The HP 64XL has a resistor layer. The resistor layer has a resistor thickness and a resistor width on the thermal barrier layer. The resistor width defines a heater width.

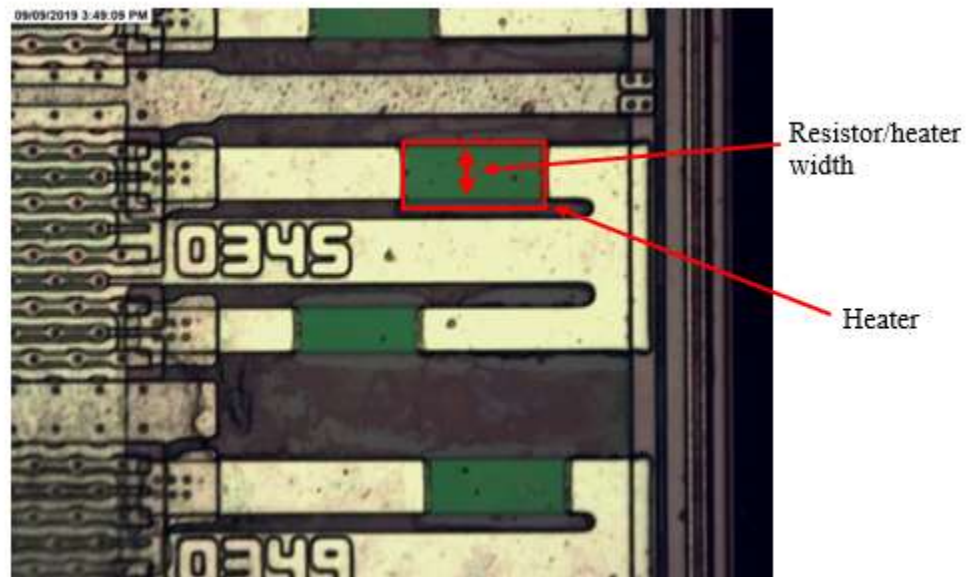

256. The heater chip of the HP 64XL has a conductor layer on the resistor layer defining a heater length. In particular, the slopes of the conductor layer define the heater length.

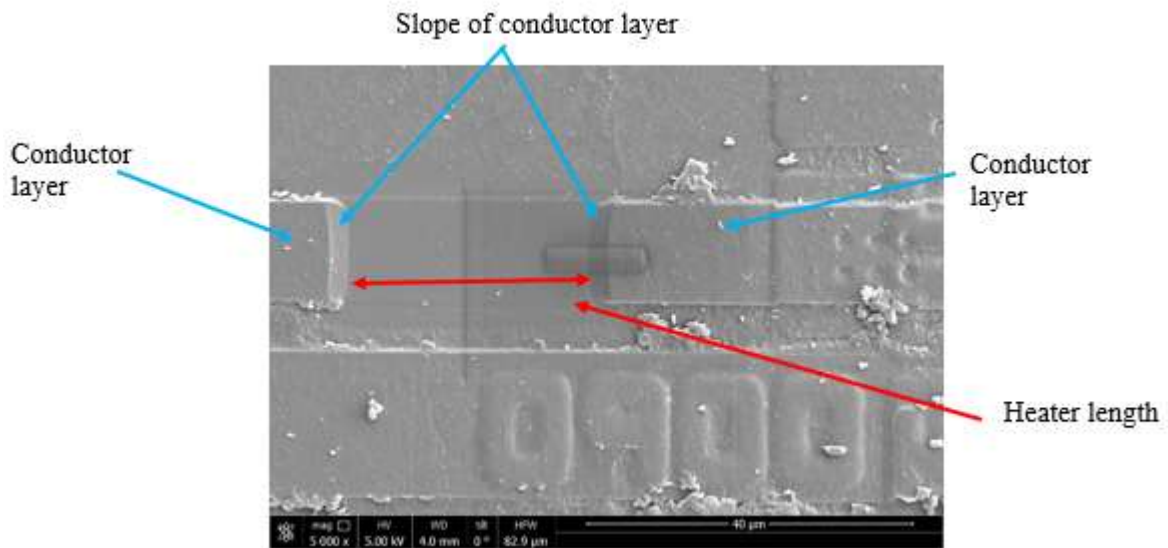
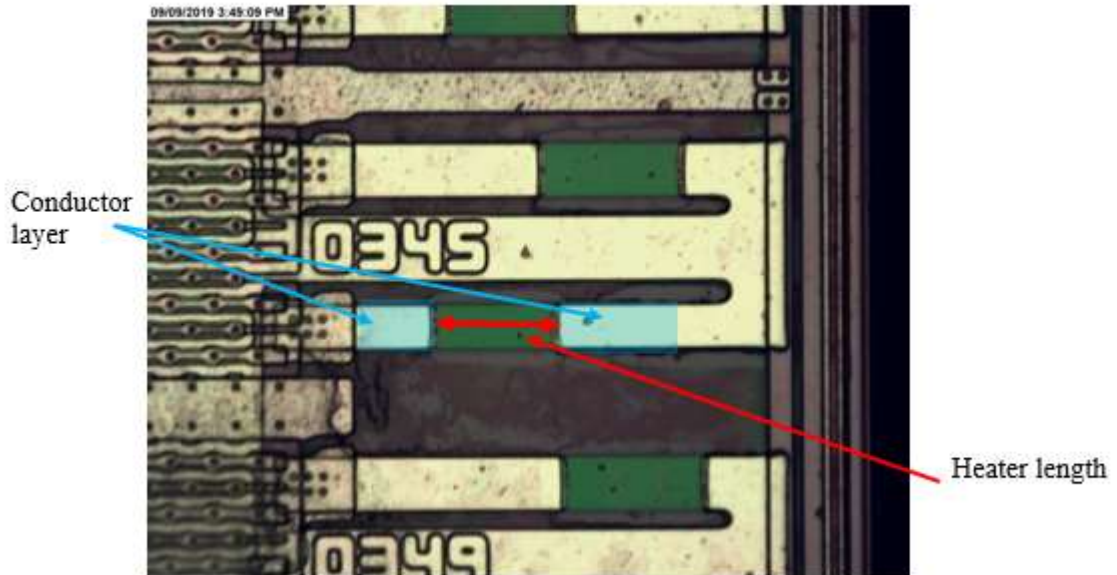

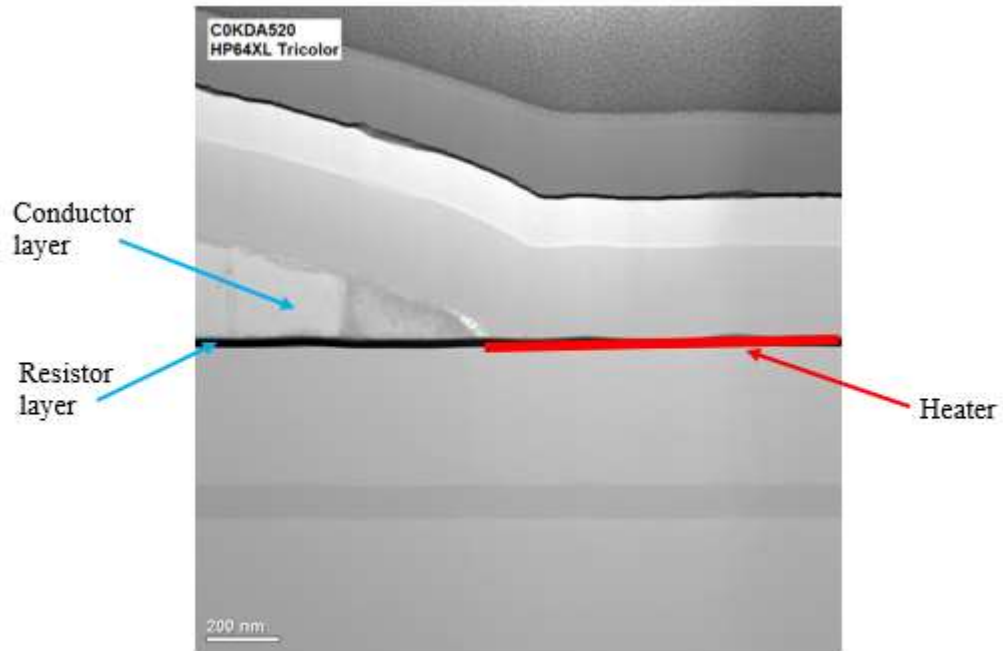

257. The heater chip of the HP 64XL has an overcoat layer having an overcoat thickness on the resistor layer.

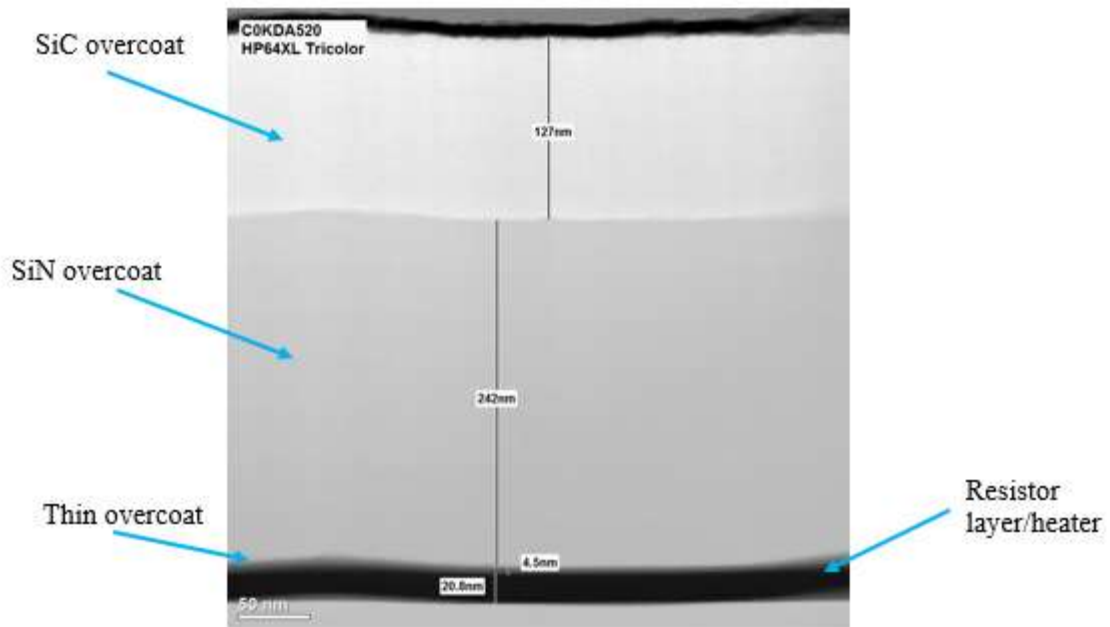

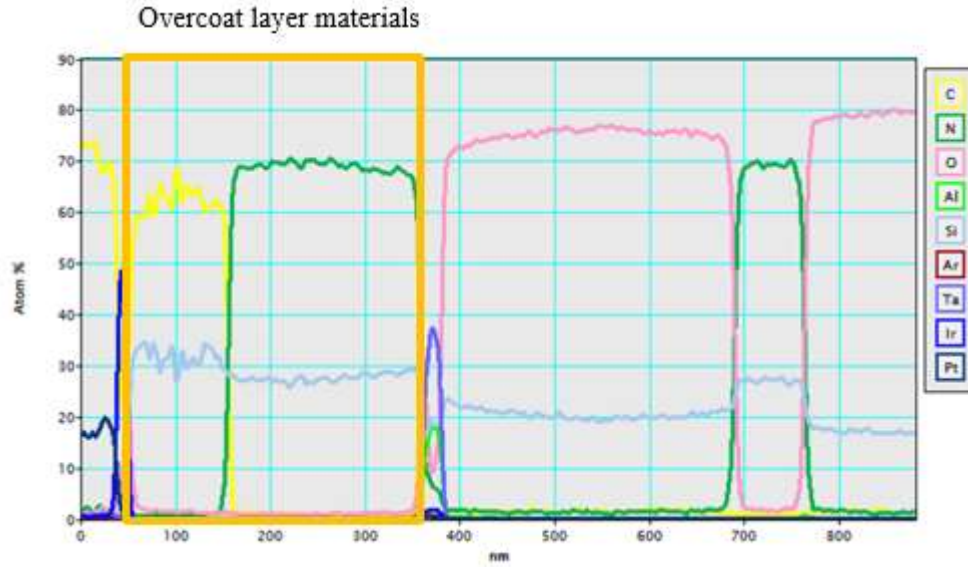

258. The overcoat thickness and the resistor thickness defining a heater thickness. The heater length ( $30.9 \mu\text{m}$  multiplied by the heater width ( $11.6 \mu\text{m}$ ) is  $358.9$  micrometers squared – i.e., less than  $400$  micrometers squared.

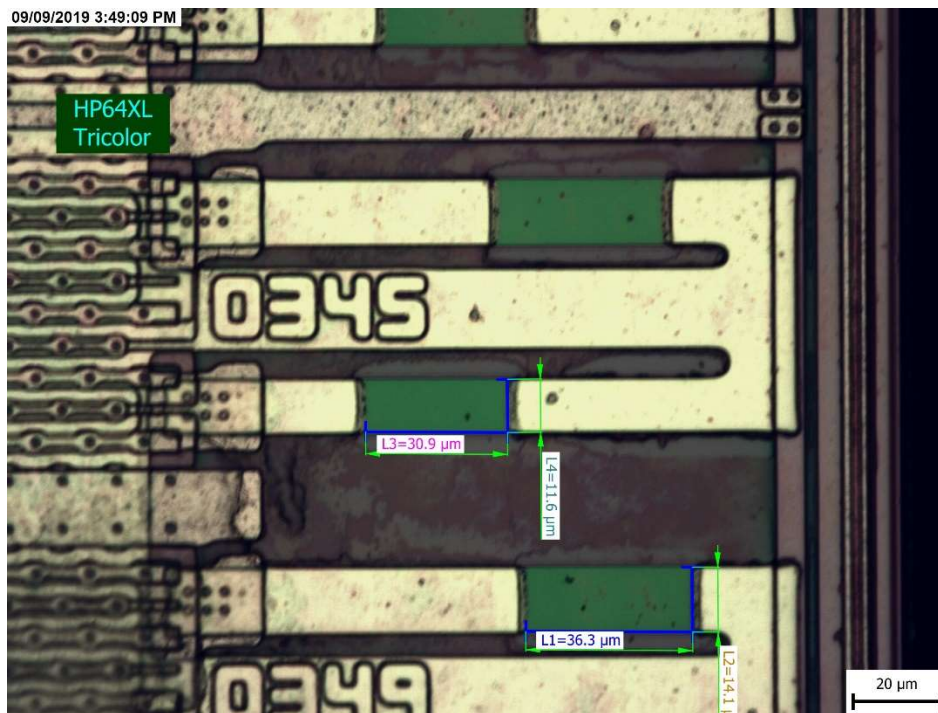

259. The heater thickness is about  $3943$  Angstroms ( $394.3 \text{ nm}$ ) which is between about  $500$  to about  $6000$  Angstroms.

260. On information and belief, HP has been on notice of the '246B patent at least as early as the filing and service of the Complaint in this action.

261. On information and belief, at least since its post-filing knowledge of the '246B patent, HP knowingly encourages, and continues to encourage, customers and resellers to directly infringe one or more claims of the '246B patent, including by HP's actions that include, without limitation, instructing and encouraging customers to use (and resellers to use, sell and offer to sell) HP inkjet printers and ink cartridges through HP's user guides/manuals, advertisement, promotional materials and instructions.

262. On information and belief, at least since its post-filing knowledge of the '246B patent, HP knows that the acts HP induced customers and resellers to take constitute patent infringement and HP's encouraging acts result in direct infringement by customers and resellers.

263. On information and belief, HP instructs and continues to instruct customers and resellers to setup, use and troubleshoot HP inkjet printers and ink cartridges including, without limitation, on HP's website which provides support on setting up and/or using these products.

264. On information and belief, HP's customers directly infringe at least claim 24 of the '246B patent through their setup and use of HP inkjet printers and ink cartridges.

265. On information and belief, HP's resellers directly infringe at least claim 24 of the '246B patent through their setup, use, sale and offer for sale of HP inkjet printers and ink cartridges.



266. On information and belief, HP is in violation of 35 U.S.C. § 271(b) and has been, at least since its post-filing knowledge of the '246B patent, indirectly infringing and continues to indirectly infringe at least claim 24 of the '246B patent by knowingly and specifically intending to induce infringement by others (including, without limitation, HP's customers and resellers) and possessing specific intent to encourage infringement by HP's customers and resellers. The heater chip of HP ink cartridges is specifically configured according to the claims of the '246B patent, is a material part of the invention and does not have substantial non-infringing uses.

267. Slingshot has been damaged by the direct and/or indirect infringement of HP and is suffering and will continue to suffer irreparable harm and damages as a result of this infringement.

**Count IX – Infringement of United States Patent No. 7,484,823**

268. The allegations set forth above are re-alleged and incorporated by reference as if they were set forth fully here.

269. HP makes, uses, sells, offers to sell and/or imports inkjet printers in the United States that infringe (literally and/or under the doctrine of equivalents) at least claims 1, 2, 5-9, 11, 12 and 15-17 of the '823 patent. HP commits acts of patent infringement through the manufacture, use, sale, offer for sale and/or importation of at least the following products:

**Inkjet printers** including, without limitation, HP OfficeJet Pro 6978.

270. On information and belief, the inkjet printer listed above is sold with ink cartridges. The ink cartridges can also be purchased separately from the inkjet printer. The ink cartridges are necessary for the operation of the inkjet printers and vice versa.

271. Infringement of the '823 patent by inkjet printers is demonstrated below using the HP OfficeJet Pro 6978 as an example.

272. HP makes, uses, sells, offers to sell and/or imports a chip (tricolor heater chip) for use with a printing device (e.g., HP OfficeJet Pro 6978 ("HP 6978")).



273. The tricolor heater chip of the HP 6978 has a first heater array positioned substantially adjacent a first via.



274. The tricolor heater chip of the HP 6978 has a second heater array positioned substantially adjacent a second via.

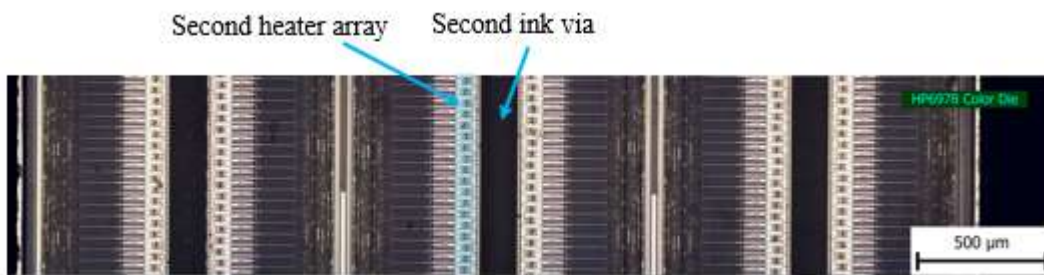

275. The tricolor heater chip of the HP 6978 has a region, positioned between the first heater array and the second heater array, and also positioned substantially adjacent to the first heater array and the second heater array.

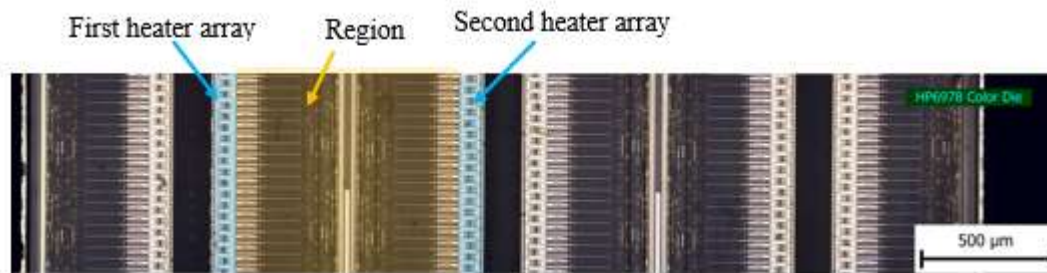

276. The tricolor heater chip of the HP 6978 has a temperature sensing element operable to sense a temperature of the region. The temperature being representative of the region. The temperature sensing element is substantially centrally disposed with respect to the region and substantially adjacent to both the first heater array and second

heater array. The temperature sensing element extends substantially the length of the first heater array and second heater array.

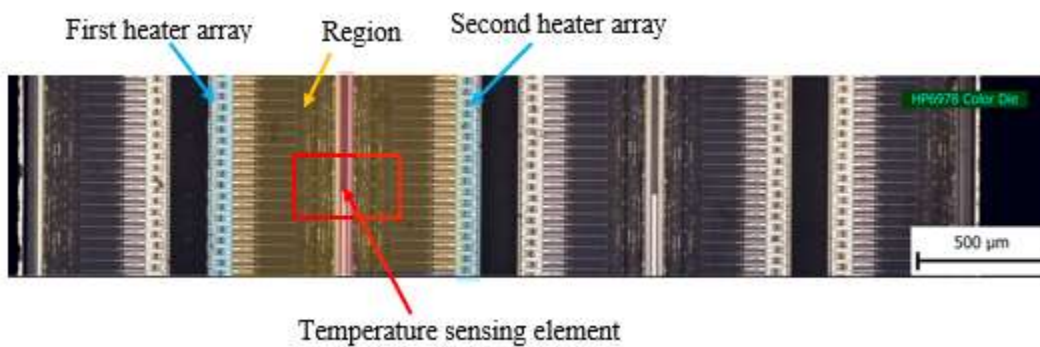

Temperature sensing element



Temperature sensing element –  
First end of heater array

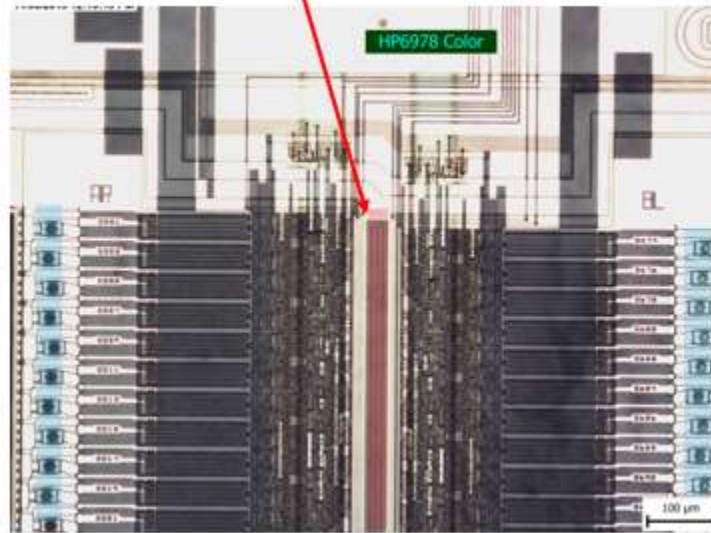

Temperature sensing element –  
Second end of heater array

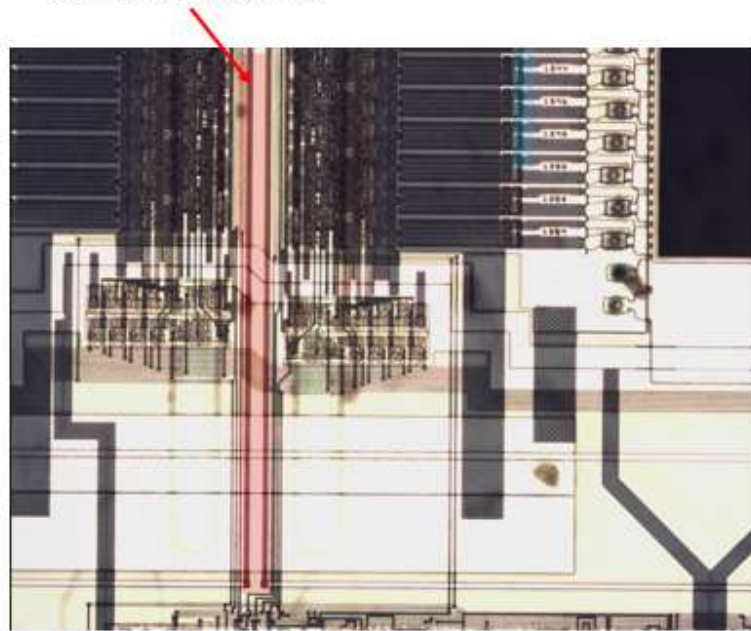

277. The first heater array and the second heater array of the tricolor heater chip of the HP 6978 are operable to receive heating responsive to the temperature of the

region sensed by the temperature sensing element. The received heating regulates the temperature of the region.

278. The tricolor heater chip of the HP 6978 has a third heater array positioned substantially adjacent the second via.

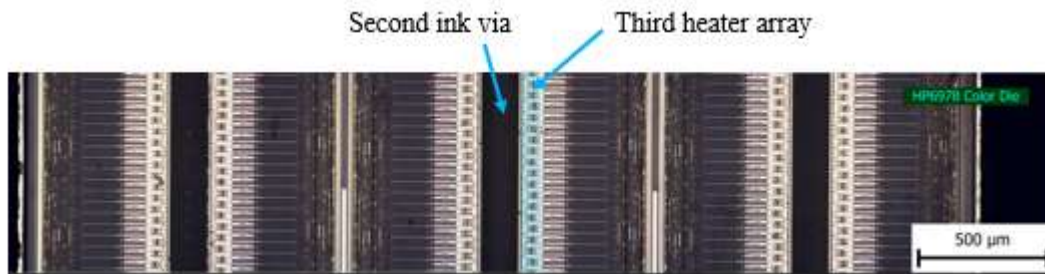

279. The tricolor heater chip of the HP 6978 has a fourth heater array positioned substantially adjacent a third via.



280. The tricolor heater chip of the HP 6978 has a second region, positioned between the third heater array and the fourth heater array, and also positioned substantially immediately adjacent to the third heater array and the fourth heater array.

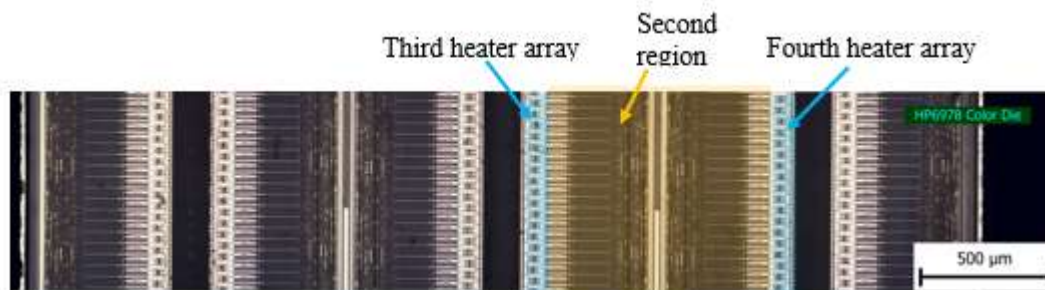

281. The tricolor heater chip of the HP 6978 has a second temperature sensing element operable to sense the temperature of the second region. The temperature sensing element is substantially centrally disposed with respect to the second region and substantially adjacent to both the third heater array and fourth heater array.

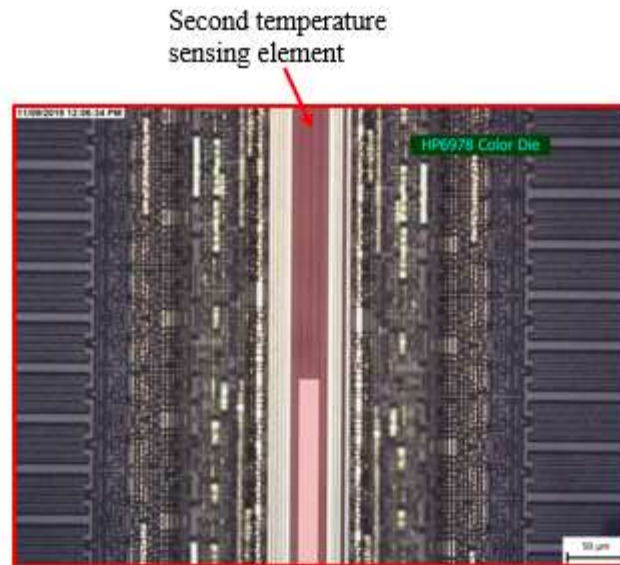
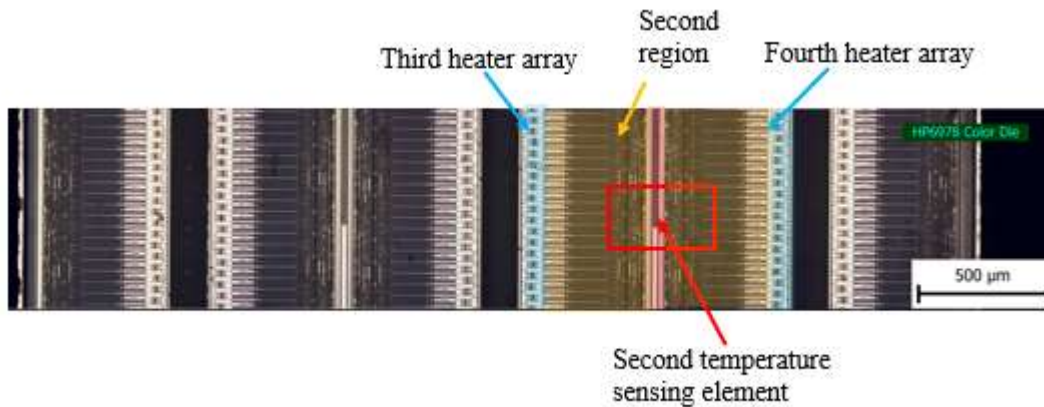

282. The third heater array and the fourth heater array of the tricolor heater chip of the HP 6978 are operable to receive heating responsive to the temperature of the

second region sensed by the temperature sensing element. The received heating regulates the temperature of the region.

283. The temperature sensing element of the tricolor heater chip of the HP 6978 comprises a temperature sensing resistor (metal traces).

284. The temperature sensing element of the tricolor heater chip of the HP 6978 is positioned at least 300 microns from each of the first heater array and the second heater array.

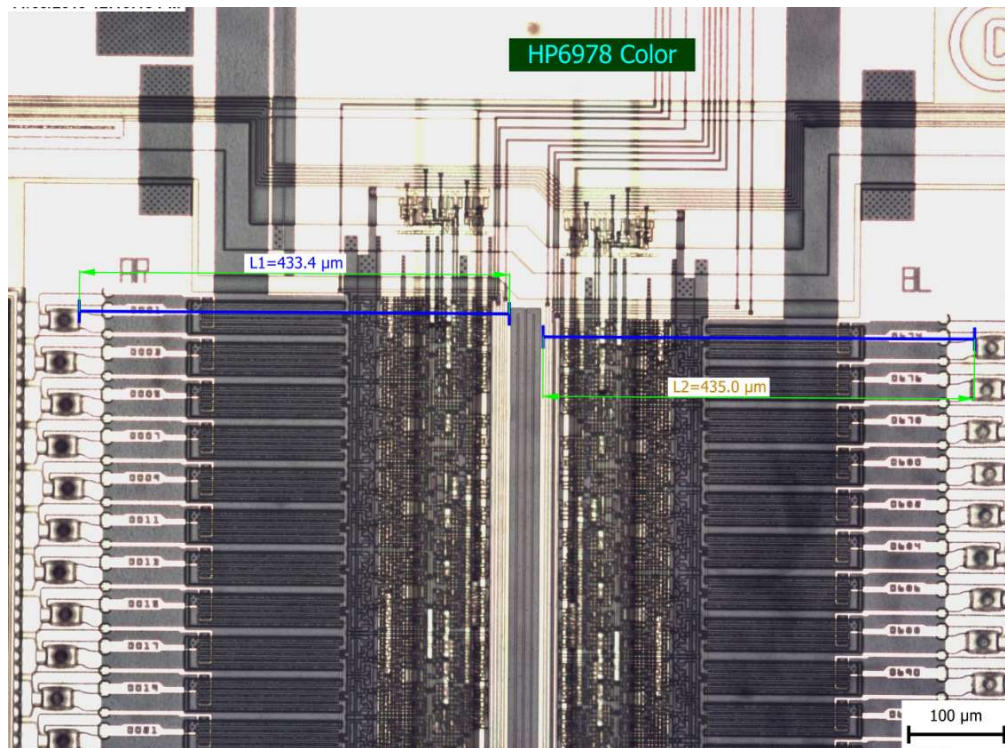

285. The temperature sensing element of the tricolor heater chip of the HP 6978 is positioned substantially planar to each of the first heater array and the second heater array.

286. The tricolor heater chip of the HP 6978 has at least one control element (e.g., main controller board) operable to receive a temperature measured by the



temperature sensing element and to heat the first heater array and the second heater array.

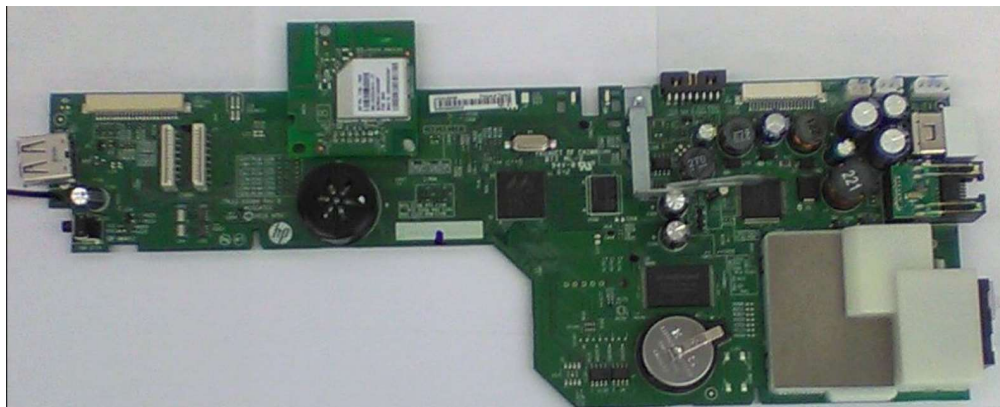

287. The temperature sensing element of the tricolor heater chip of the HP 6978 positioned between the first heater array and the second heater array is different than the second temperature sensing element positioned between the third heater array and the fourth heater array.

288. The first heater array and the second heater array of the tricolor heater chip of the HP 6978 are operable to receive non-nucleating heating (e.g., heating that does not reach a high enough temperature to make a steam bubble) responsive to the temperature of the region sensed by the temperature sensing element.

289. HP (or those acting on their behalf) performs the method of at least claims 11, 12 and 15-17 of the '823 patent when fabricating chips (as described above) for use with a printing device (e.g., HP 6978).

290. On information and belief, HP has been on notice of the '823 patent at least as early as the filing and service of the Complaint in this action.

291. On information and belief, at least since its post-filing knowledge of the '823 patent, HP knowingly encourages, and continues to encourage, customers and resellers to directly infringe one or more claims of the '823 patent, including by HP's actions that include, without limitation, instructing and encouraging customers to use (and resellers to use, sell and offer to sell) HP inkjet printers through HP's user guides/manuals, advertisement, promotional materials and instructions.

292. On information and belief, at least since its post-filing knowledge of the '823 patent, HP knows that the acts HP induced customers and resellers to take constitute patent infringement and HP's encouraging acts result in direct infringement by customers and resellers.

293. On information and belief, HP instructs and continues to instruct customers and resellers to setup, use and troubleshoot HP inkjet printers including, without limitation, on HP's website which provides support on setting up and/or using these products.

294. On information and belief, HP's customers directly infringe at least claims 1, 2 and 5-9 of the '823 patent through their setup and use of HP inkjet printers.

295. On information and belief, HP's resellers directly infringe at least claims 1, 2 and 5-9 of the '823 patent through their setup, use, sale and offer for sale of HP inkjet printers.

296. On information and belief, HP is in violation of 35 U.S.C. § 271(b) and has been, at least since its post-filing knowledge of the '823 patent, indirectly infringing and continues to indirectly infringe at least claims 1, 2 and 5-9 of the '823 patent by

knowingly and specifically intending to induce infringement by others (including, without limitation, HP's customers and resellers) and possessing specific intent to encourage infringement by HP's customers and resellers. The heater chip of HP inkjet printers is specifically configured according to the claims of the '823 patent, is a material part of the invention and does not have substantial non-infringing uses.

297. Slingshot has been damaged by the direct and/or indirect infringement of HP and is suffering and will continue to suffer irreparable harm and damages as a result of this infringement.

**Count X - Infringement of United States Patent No. 7,559,629**

298. The allegations set forth above are re-alleged and incorporated by reference as if they were set forth fully here.

299. HP makes, uses, sells, offers to sell and/or imports inkjet printers in the United States that infringe (literally and/or under the doctrine of equivalents) at least claims 1-4, 8, 9 and 14 of the '629 patent. HP commits acts of patent infringement through the manufacture, use, sale, offer for sale and/or importation of at least the following products:

**Inkjet printers** including, without limitation, HP OfficeJet Pro 6978.

300. On information and belief, the inkjet printer listed above is sold with ink cartridges. The ink cartridges can also be purchased separately from the inkjet printer. The ink cartridges are necessary for the operation of the inkjet printers and vice versa.

301. Infringement of the '629 patent by inkjet printers is demonstrated below using the HP OfficeJet Pro 6978 as an example.

302. HP makes, uses, sells, offers to sell and/or imports a chip/integrated multi-via heater chip for use in a printing device (e.g., HP OfficeJet Pro 6978 (“HP 6978”)).



303. The tricolor heater chip of the HP 6978 has (a) a first heater array with a left side and a right side, (b) a first ink via placed on the left side of the first heater array, (c) a second heater array with a left side and a right side, the right side of the first heater

array facing the left side of the second heater array (the first heater array and the second heater array are positioned opposite one another so that the right side of the first heater array is facing the left side of the second heater array), (d) a second ink via placed on the right side of the second heater array and (e) at least one logic array including a first and a second set of logic cells arranged in a non-contiguous hybrid arrangement, the at least one logic array is disposed substantially between the first heater array and the second heater array.

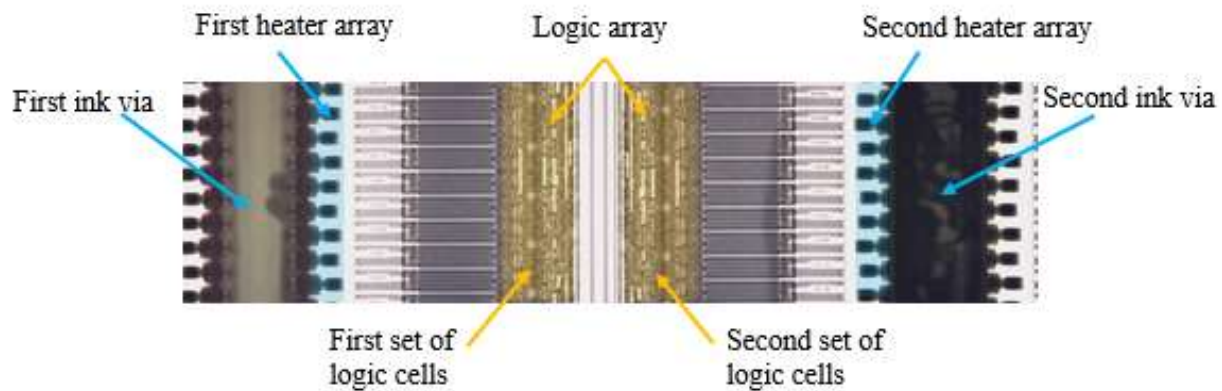

304. The first set of logic cells addresses and controls the first heater array and the second set of logic cells addresses and controls the second heater array, which allows the first ink via and second ink via to be simultaneously controlled by the at least one logic array. The at least one logic array of the tricolor heater chip of the HP 6978 is substantially parallel with the first heater array and second heater array. At least a portion of the first set of logic cells and at least a portion of the second set of logic cells are substantially aligned.

305. The tricolor heater chip of the HP 6978 has a third heater array and a fourth heater array. The third heater array and first heater array sandwich the first ink via and the fourth heater array and the second heater array sandwich the second ink via.



306. The first and second ink via of the tricolor heater chip of the HP 6978 is one of a cyan ink via, a magenta ink via and a yellow ink via.

307. The first heater array of the tricolor heater chip of the HP 6978 has a plurality of blocks of heaters and the second heater array has a plurality of blocks of heaters. Each block of heaters in the first heater array is addressed by at least a portion of the first logic cells. Each block of heaters in the second heater array is addressed by at least a portion of the second logic cells.

308. The at least one logic array of the tricolor heater chip of the HP 6978 includes a first logic array for addressing the first heater array and a second logic array for addressing the second heater array. The first logic array is substantially parallel to the second logic array.

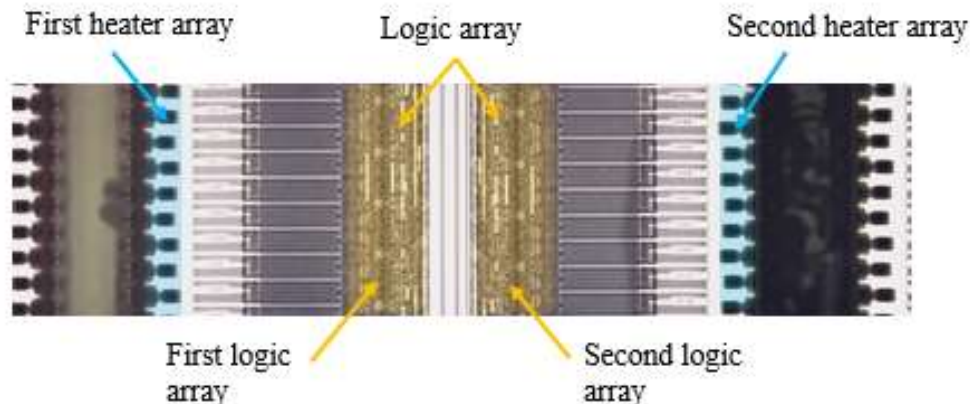

309. On information and belief, HP has been on notice of the '629 patent at least as early as the filing and service of the Complaint in this action.

310. On information and belief, at least since its post-filing knowledge of the '629 patent, HP knowingly encourages, and continues to encourage, customers and resellers to directly infringe one or more claims of the '629 patent, including by HP's actions that include, without limitation, instructing and encouraging customers to use (and resellers to use, sell and offer to sell) HP inkjet printers through HP's user guides/manuals, advertisement, promotional materials and instructions.

311. On information and belief, at least since its post-filing knowledge of the '629 patent, HP knows that the acts HP induced customers and resellers to take constitute patent infringement and HP's encouraging acts result in direct infringement by customers and resellers.

312. On information and belief, HP instructs and continues to instruct customers and resellers to setup, use and troubleshoot HP inkjet printers including, without limitation, on HP's website which provides support on setting up and/or using these products.

313. On information and belief, HP's customers directly infringe at least claims 1-4, 8, 9 and 14 of the '629 patent through their setup and use of HP inkjet printers.

314. On information and belief, HP's resellers directly infringe at least claims 1-4, 8, 9 and 14 of the '629 patent through their setup, use, sale and offer for sale of HP inkjet printers.

315. On information and belief, HP is in violation of 35 U.S.C. § 271(b) and has been, at least since its post-filing knowledge of the '629 patent, indirectly infringing and continues to indirectly infringe at least claims 1-4, 8, 9 and 14 of the '629 patent by knowingly and specifically intending to induce infringement by others (including, without limitation, HP's customers and resellers) and possessing specific intent to encourage infringement by HP's customers and resellers. The heater chip of HP inkjet printers is specifically configured according to the claims of the '629 patent, is a material part of the invention and does not have substantial non-infringing uses.

316. Slingshot has been damaged by the direct and/or indirect infringement of HP and is suffering and will continue to suffer irreparable harm and damages as a result of this infringement.

**JURY DEMANDED**

Pursuant to Rule 38(b) of the Federal Rules of Civil Procedure, Slingshot hereby requests a trial by jury on all issues so triable.

**PRAYER FOR RELIEF**

WHEREFORE, Slingshot respectfully requests that the Court enter judgment in its favor and against HP as follows:



- a. finding that HP has infringed one or more claims of the '587 patent;
- b. finding that HP has infringed one or more claims of the '563 patent;
- c. finding that HP has infringed one or more claims of the '246A patent;
- d. finding that HP has infringed one or more claims of the '575 patent;
- e. finding that HP has infringed one or more claims of the '012 patent;
- f. finding that HP has infringed one or more claims of the '341 patent;
- g. finding that HP has infringed one or more claims of the '864 patent;
- h. finding that HP has infringed one or more claims of the '246B patent;
- i. finding that HP has infringed one or more claims of the '823 patent;
- j. finding that HP has infringed one or more claims of the '629 patent;
- k. awarding Slingshot damages under 35 U.S.C. § 284, or otherwise permitted by law, including supplemental damages for any continued post-verdict infringement;
- l. awarding Slingshot pre-judgment and post-judgment interest on the damages award and costs;
- m. awarding cost of this action (including all disbursements) and attorney fees pursuant to 35 U.S.C. § 285, or as otherwise permitted by the law; and
- n. awarding such other costs and further relief that the Court determines to be just and equitable.

Dated: September 20, 2019

Respectfully submitted,

/s/ Raymond W. Mort, III

Raymond W. Mort, III

Texas State Bar No. 00791308

[raymort@austinlaw.com](mailto:raymort@austinlaw.com)

THE MORT LAW FIRM, PLLC  
100 Congress Avenue, Suite 2000  
Austin, Texas 78701  
Tel/Fax: 512-865-7950

*Of Counsel:*

Ronald M. Daignault (*pro hac vice* to be filed)

Chandran B. Iyer (*pro hac vice* to be filed)

Michael A. Siem (*pro hac vice* to be filed)

Jason S. Charkow (*pro hac vice* to be filed)

[rdaignault@goldbergsegalla.com](mailto:rdaignault@goldbergsegalla.com)

[ciyer@goldbergsegalla.com](mailto:ciyer@goldbergsegalla.com)

[msiem@goldbergsegalla.com](mailto:msiem@goldbergsegalla.com)

[jcharkow@goldbergsegalla.com](mailto:jcharkow@goldbergsegalla.com)

GOLDBERG SEGALLA LLP  
711 Third Avenue, Suite 1900  
New York, New York 10017  
Telephone: (646) 292-8700

Richard Juang (*pro hac vice* to be filed)

[rjuang@goldbergsegalla.com](mailto:rjuang@goldbergsegalla.com)

GOLDBERG SEGALLA LLP  
8000 Maryland Avenue, Suite 640  
St. Louis, Missouri 63105  
Telephone: (314) 446-3367

Attorneys for Slingshot Printing LLC