

**IN THE UNITED STATES DISTRICT COURT
FOR THE DISTRICT OF DELAWARE**

SENTIENT SENSORS, LLC,

Plaintiff,

v.

CYPRESS SEMICONDUCTOR
CORPORATION,

Defendant.

Civil Action No. 1:19-cv-01868-MN

JURY TRIAL DEMANDED

**FIRST AMENDED COMPLAINT FOR PATENT
INFRINGEMENT**

This is an action for patent infringement in which Plaintiff Sentient Sensors, LLC (“Sentient” or “Plaintiff”) by and for its First Amended¹ Complaint against Defendant Cypress Semiconductor Corporation (“Cypress” or “Defendant”) hereby makes the following allegations:

THE PARTIES

1. Sentient Sensors, LLC is a New Mexico Limited Liability Corporation, with its principal place of business at 6022 Constitution Ave. NE, Albuquerque, New Mexico.
2. SS was founded by inventor and entrepreneur Kenneth Blemel. Mr. Blemel has been operating in Albuquerque, New Mexico for over 30 years. Mr. Blemel, an engineer by training and vocation, has developed numerous technologies in the areas of programmable logic devices, instrumentation and embedded systems over his long career. Mr. Blemel has

¹ A redline version of the First Amended Complaint indicating the changes from the original complaint is attached as Exhibit “X.”

successfully guided multiple research and development programs in several electronic hardware sub-disciplines, including the program culminating in the issuance of the patent described herein.

3. Cypress Semiconductor Corporation is a Delaware corporation with its principal place of business at 198 Champion Court, San Jose, California 95134. Cypress may be served through its registered agent Corporation Service Company, 251 Little Falls Drive, Wilmington, Delaware 19808.

4. Cypress is registered to do business in the State of Delaware and has been since at least September 26, 1986.

JURISDICTION AND VENUE

5. This is an action for patent infringement arising under 35 U.S.C. §100, et seq., §§ 271-81, and §§ 284-85, among others. This Court has subject matter over this action pursuant to 28 U.S.C. §§ 1331 and 1338(a).

6. Venue is proper in this judicial district pursuant to 28 U.S.C. §1400(b). Upon information and belief, Cypress maintains a regular and established place of business within this district and has committed acts of infringement within this judicial district by selling the accused instrumentalities here. According to public records, Cypress is a corporation organized under the laws of the State of Delaware, and therefore resides in this judicial district

7. More specifically, personal jurisdiction is proper because, Cypress resides in this judicial district and transacts business from this district, including infringing activities, and also targets customers within this district for its infringing products, such that the Court's exercise of personal jurisdiction would not offend traditional notions of fair play and substantial justice.

BACKGROUND

6. This lawsuit asserts causes of action for infringement of United States Patent No. 6,938,177 (the '177 Patent). A true and correct copy of the '177 patent is attached hereto as

Exhibit A.

7. The technology described and claimed in the '177 Patent was invented by Kenneth G. Blemel.

8. The '177 Patent was properly assigned to Sentient Sensors, LLC; and Sentient Sensors, LLC has all rights, title and interest in and to the '177 Patent and to any and all other future inventions that disclose and claim improvements over the subject matter disclosed, including the right to sue for and recover or otherwise collect damages in respect of past acts of infringement thereof.

9. The inventions described and claimed in the '177 Patent have been used to provide instrumentation for monitoring and control of systems and components of instruments, aircraft, ships, homes and machinery. A few examples include:

- Monitoring signals on UH-60 helicopters
- Instrumentation for prognostic health monitoring of aircraft propulsion systems
- Instrumentation interface to paired flight data recorders
- Instrumentation monitoring health signatures of aircraft propulsion systems
- Instrumentation for monitoring and control of diesel generator sets
- Instrumentation for monitoring health of ballistic missiles
- Instrumentation of hybrid micro-grids
- Edge node flight data collection and analysis for B-52 and other military aircraft

10. The teachings of the '177 Patent enable the rapid prototyping and deployment of complex hardware and software platforms, providing enhanced flexibility for various real-world applications. As just one example, the '177 Patent describes and claims an instrument controller containing a microprocessor for controlling inputs and outputs, a separate field programmable gate array ("FPGA") which can be used as a freely re-configurable parallel processor, and a real-time quartz controlled clock for time-stamping of data before it is stored in non-volatile memory, all of which contribute to the creation of a development platform that allows for a wide range of

hardware controller solutions.

11. At the time of the filing of the patent application that resulted in the '177 Patent, the technology provided for a novel and innovative in-field control and monitoring system with time-stamped selectable collection and digitizing of multiple analog and digital data streams at variable bit depths. The technology enabled, *inter alia*, real-time concurrent processing of data to measure and control stresses on components and generating alerts for anomalous conditions. The use of FPGA-based instrumentation is now widespread in diverse applications including machinery control, field programmable automation of process lines, telecommunications, and diagnostic and prognostic health monitoring of equipment.

12. The research and development program that led to the innovations described and claimed in the '177 Patent was funded in part by the U.S. Air Force and conducted at Kirtland Air Force base in Albuquerque, New Mexico. These advancements were initially directed toward use in the Strategic Defense Initiative program initiated in the 1980s, colloquially known at the time as "Star Wars." As a result of a collaborative research and development agreement ("CRADA") with the U.S. government, the Air Force secured a license to practice the inventions of the '177 Patent. Hardware purveyors such as Cypress have adapted the inventions of the '177 Patent for their own commercial exploitation, for example, as automotive control devices, and are used for controllers of wide array of electronic devices ranging from electric tooth brushes to touch screen and set top box controllers.

COUNT I
Direct Infringement of the '177 Patent

13. Sentient incorporates by reference the allegations set forth in the preceding paragraphs.

14. On August 30, 2005, the '177 Patent, entitled "Multi-Chip Module Smart Controller," was duly and legally issued by the United States Patent and Trademark Office to

Kenneth Blemel as the sole named inventor.

15. Sentient is the assignee and the owner of the '177 Patent, holding all rights, title and interest in and to the '177 Patent, and Sentient has the right to sue and recover damages for infringement thereof.

16. The '177 Patent and its underlying patent application have been cited by 23 United States patents and patent applications as relevant prior art. Specifically, patents issued to the following companies have cited the '177 Patent and its underlying patent application as relevant prior art:

- Intel Corp.
- Advanced Micro Devices (AMD)
- STM Microelectronics S.r.L.
- Trend Micro Corp.
- Benq Inc.
- Emerson Electric GmbH
- SPM Instrumentation AB
- RMT, Inc.
- NXP B.V.
- Verily Life Sciences, LLC

17. Cypress is not licensed under the '177 Patent, yet Cypress actively practices the '177 Patent for its own profit and financial benefit.

18. Upon information and belief, Cypress has directly infringed, and is now directly infringing, at least Claim 1 of the '177 Patent by making, using, importing, providing, supplying, distributing, selling, and offering to sell infringing products and systems, and is thus liable to Sentient for Cypress's infringement pursuant to 35 U.S.C. § 271. Cypress's infringing products and systems include at least the Programmable System on a Chip ("PSoC®") lines of system-on-

a- chip (SoC) products including the PSoC 3, PSoC 4, PSoC 5, and PSoC 6 product lines. Cypress is therefore liable for direct infringement of the '177 Patent pursuant to 35 U.S.C. § 271(a). Collectively referred to herein as the "177 PSoC Products."

19. Upon information and belief, Cypress has willfully infringed, and continues to willfully infringe, at least Claim 1 of the '177 Patent by making, using, importing, providing, supplying, distributing, selling, and offering to sell infringing products and systems, and is thus liable to Sentient for Cypress's infringement pursuant to 35 U.S.C. § 271. Cypress's willfully infringing products and systems include at least the Programmable System on a Chip ("PSoC®") lines of system-on-a- chip (SoC) products including the PSoC 3, PSoC 4, PSoC 5, and PSoC 6 product lines. Cypress has done so and continues to do so despite an objectively high likelihood that such actions constitute infringement and despite being on notice that such actions constitute infringement at least as of the date of service of Sentient's original Complaint, Exhibit "B."

20. On information and belief, one or more Cypress subsidiaries and/or affiliates use the Cypress '177 Products in regular business operations.

21. For example, Cypress's '177 PSoC products meets all limitations of at least Claim 1 of the '177 Patent.

22. One or more of the Cypress '177 Products include technology for an instrument controller such as a Developer Kit.

CY8CKIT-001 PSoC® Development Kit

Last Updated:

Nov 01, 2018

The CY8CKIT-001 PSoC® Development Kit (DVK) provides a common development platform where you can prototype and evaluate different solutions using any one of the PSoC 1, PSoC 3, PSoC 4, or PSoC 5 architectures.

The PSoC DVK gives you a practical understanding of PSoC technology. In addition, the kit includes several example projects with step-by-step instructions to enable you to easily get

started developing PSoC solutions. This kit includes PSoC 1, PSoC 3, PSoC 4 and PSoC 5LP Family Processor Modules.



Kit Contents:

- PSoC Development Board
- PSoC 1 CY8C28 Family Processor Module
- PSoC 3 CY8C38 Family Processor Module
- [PSoC 4 CY8C42 Family Processor Module \(Sold Separately\)](#)
- PSoC 5 CY8C58LP Family Processor Module
 - MiniProg3 Program/Debug Device
 - Program/Debug Ribbon Cable
 - USB Cable
 - 12V AC Power Adapter
 - Quick Start Guide
- Kit CDs, which includes: PSoC Creator™, PSoC Designer™, PSoC Programmer, Projects, and Documentation

<https://www.cypress.com/documentation/development-kitsboards/cy8ckit-001-psoc-development-kit>

23. Cypress documentation describes one or more of the Cypress '177 Products as including SRAM.



5.6 External Memory Interface

CY8C56LP provides an External Memory Interface (EMIF) for connecting to external memory devices. The connection allows read and write accesses to external memories. The EMIF operates in conjunction with UDBs, I/O ports, and other hardware to generate external memory address and control signals. At 33 MHz, each memory access cycle takes four bus clock cycles. Figure 5-1 is the EMIF block diagram. The EMIF supports synchronous and asynchronous memories. The CY8C56LP only supports one type of external memory device at a time.

External memory is located in the Cortex-M3 external RAM space; it can use up to 24 address bits. See Table 5-4 on page 22 Memory Map on page 22. The memory can be 8 or 16 bits wide.

Cortex-M3 instructions can be fetched from external memory if it is 16-bit. Other limitations apply; for details, see application note AN89610, PSoc[®] 4 and PSoc 5LP Arm Cortex Code Optimization. There is no provision for code security in external memory. If code must be kept secure, then it should be placed in internal flash. See Flash Security on page 19 and Device Security on page 64.

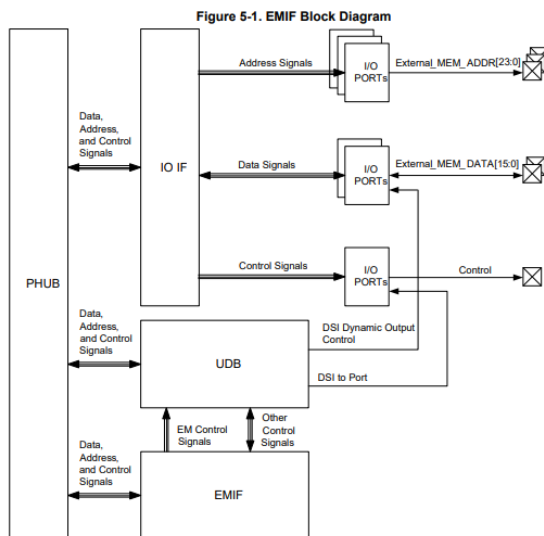

24. Cypress documentation describes one or more of the Cypress '177 Products as including an ARM Cortex processing core which interfaces with both volatile and non-volatile memory.

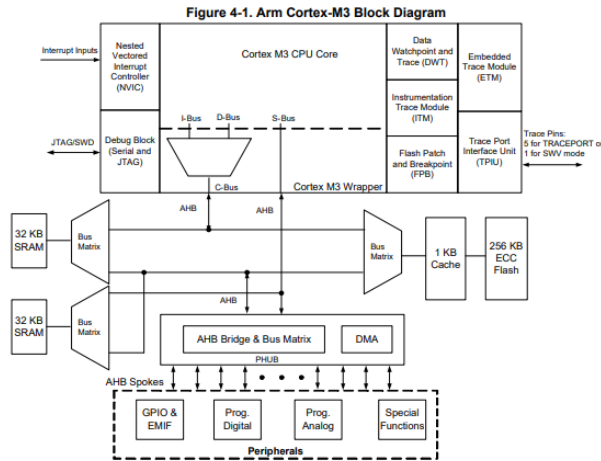

The Cortex-M3 CPU subsystem includes these features:

- Arm Cortex-M3 CPU
- Programmable Nested Vectored Interrupt Controller (NVIC), tightly integrated with the CPU core
- Full featured debug and trace modules, tightly integrated with the CPU core
- Up to 256 KB of flash memory, 2 KB of EEPROM, and 64 KB of SRAM
- Cache controller
- Peripheral HUB (PHUB)
- DMA controller
- External Memory Interface (EMIF)

4.1.1 Cortex-M3 Features

The Cortex-M3 CPU features include:

- 4 GB address space. Predefined address regions for code, data, and peripherals. Multiple buses for efficient and simultaneous accesses of instructions, data, and peripherals.
- The Thumb[®]-2 instruction set, which offers Arm-level performance at Thumb-level code density. This includes 16-bit and 32-bit instructions. Advanced instructions include:
 - Bit-field control
 - Hardware multiply and divide
 - Saturation
 - If-Then
 - Wait for events and interrupts
 - Exclusive access and barrier
 - Special register access
- The Cortex-M3 does not support Arm instructions.
- Bit-band support for the SRAM region. Atomic bit-level write and read operations for SRAM addresses.
- Unaligned data storage and access. Contiguous storage of data of different byte lengths.
- Operation at two privilege levels (privileged and user) and in two modes (thread and handler). Some instructions can only be executed at the privileged level. There are also two stack pointers: Main (MSP) and Process (PSP). These features support a multitasking operating system running one or more user-level processes.
- Extensive interrupt and system exception support.

25. Cypress documentation describes one or more of the Cypress '177 Products as including an ARM Cortex processing core which is capable of both high and low frequency operations.

- Programmable clocking
 - 3- to 74-MHz internal oscillator, 1% accuracy at 3 MHz
 - 4- to 25-MHz external crystal oscillator
 - Internal PLL clock generation up to 80 MHz
 - Low-power internal oscillator at 1, 33, and 100 kHz
 - 32.768-kHz external watch crystal oscillator
 - 12 clock dividers routable to any peripheral or I/O

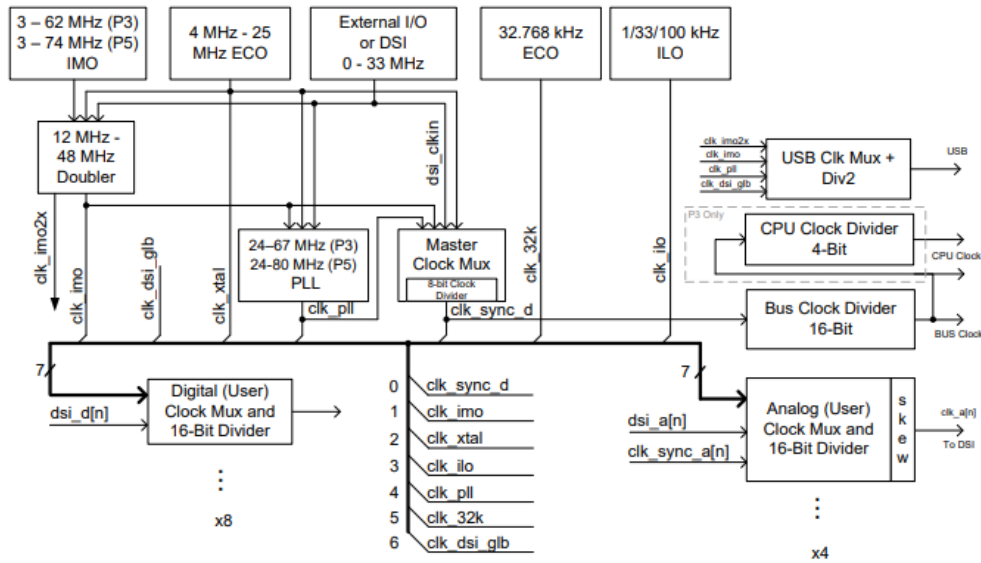

26. Cypress documentation describes one or more of the Cypress '177 Products as including having an SRAM memory and the ARM processing core can boot independently without first retrieving a program stored in non-volatile memory.

■ **Memories**

- Up to 256 KB program flash, with cache and security features
- Up to 32 KB additional flash for error correcting code (ECC)
- Up to 64 KB RAM
- 2 KB EEPROM

27. Cypress documentation describes one or more of the Cypress '177 Products as including several general-purpose clock sources for low frequency and high frequency operation.

■ **Programmable clocking**

- 3- to 74-MHz internal oscillator, 1% accuracy at 3 MHz
- 4- to 25-MHz external crystal oscillator
- Internal PLL clock generation up to 80 MHz
- Low-power internal oscillator at 1, 33, and 100 kHz
- 32.768-kHz external watch crystal oscillator
- 12 clock dividers routable to any peripheral or I/O

28. Cypress documentation describes one or more of the Cypress '177 Products as including multiple programmable logic devices based on universal digital blocks that can be configured to run independent processes in parallel with the ARM processing core.

- 20 to 24 universal digital blocks (UDB), programmable to create any number of functions:
 - 8-, 16-, 24-, and 32-bit timers, counters, and PWMs
 - I²C, UART, SPI, I2S, LIN 2.0 interfaces
 - Cyclic redundancy check (CRC)
 - Pseudo random sequence (PRS) generators
 - Quadrature decoders
 - Gate-level logic functions

7.3 UDB Array Description

Figure 7-7 shows an example of a 16 UDB array. In addition to the array core, there are a DSI routing interfaces at the top and bottom of the array. Other interfaces that are not explicitly shown include the system interfaces for bus and clock distribution. The UDB array includes multiple horizontal and vertical routing channels each comprised of 96 wires. The wire connections to UDBs, at horizontal/vertical intersection and at the DSI interface are highly permutable providing efficient automatic routing in PSoC Creator. Additionally the routing allows wire by wire segmentation along the vertical and horizontal routing to further increase routing flexibility and capability.

Figure 7-7. Digital System Interface Structure

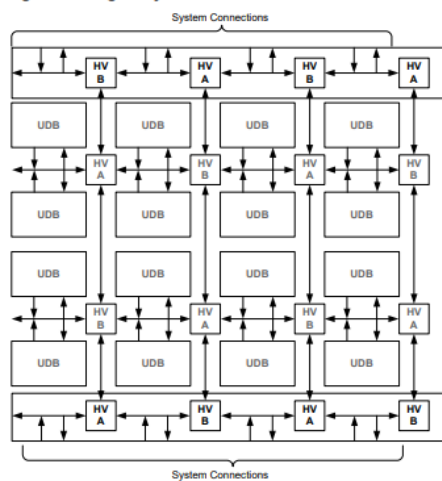

7.3.1 UDB Array Programmable Resources

Figure 7-8 shows an example of how functions are mapped into a bank of 16 UDBs. The primary programmable resources of the UDB are two PLDs, one datapath and one status/control register. These resources are allocated independently, because they have independently selectable clocks, and therefore unused blocks are allocated to other unrelated functions.

An example of this is the 8-bit Timer in the upper left corner of the array. This function only requires one datapath in the UDB, and therefore the PLD resources may be allocated to another function. A function such as a Quadrature Decoder may require more PLD logic than one UDB can supply and in this case can

utilize the unused PLD blocks in the 8-bit Timer UDB. Programmable resources in the UDB array are generally homogeneous so functions can be mapped to arbitrary boundaries in the array.

Figure 7-8. Function Mapping Example in a Bank of UDBs

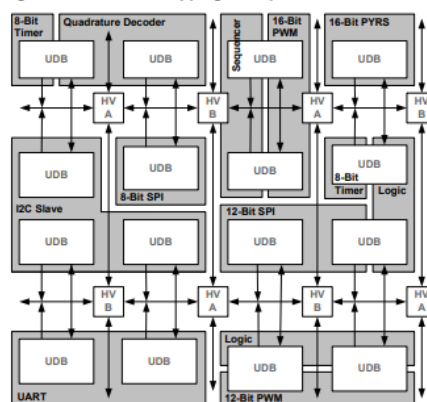

7.4 DSI Routing Interface Description

The DSI routing interface is a continuation of the horizontal and vertical routing channels at the top and bottom of the UDB array core. It provides general purpose programmable routing between device peripherals, including UDBs, I/Os, analog peripherals, interrupts, DMA and fixed function peripherals.

Figure 7-9 illustrates the concept of the digital system interconnect, which connects the UDB array routing matrix with other device peripherals. Any digital core or fixed function peripheral that needs programmable routing is connected to this interface.

Signals in this category include:

- Interrupt requests from all digital peripherals in the system.
- DMA requests from all digital peripherals in the system.
- Digital peripheral data signals that need flexible routing to I/Os.
- Digital peripheral data signals that need connections to UDBs.
- Connections to the interrupt and DMA controllers.
- Connection to I/O pins.
- Connection to analog system digital signals.

29. Cypress documentation describes one or more of the Cypress '177 Products as including a delta sigma ADC that may be programmed to multiple bit depths.

- Analog peripherals
 - Configurable 8- to 12-bit delta-sigma ADC
 - Up to two 12-bit SAR ADCs

30. Cypress documentation describes one or more of the Cypress '177 Products as including programmable logic for signal processing applications.

- 20 to 24 universal digital blocks (UDB), programmable to create any number of functions:
 - 8-, 16-, 24-, and 32-bit timers, counters, and PWMs
 - I²C, UART, SPI, I2S, LIN 2.0 interfaces
 - Cyclic redundancy check (CRC)
 - Pseudo random sequence (PRS) generators
 - Quadrature decoders
 - Gate-level logic functions

31. Cypress documentation describes one or more of the Cypress '177 Products as including a flexible and configurable routing architecture for internal signal distribution and routing.

Figure 7-9. Digital System Interconnect

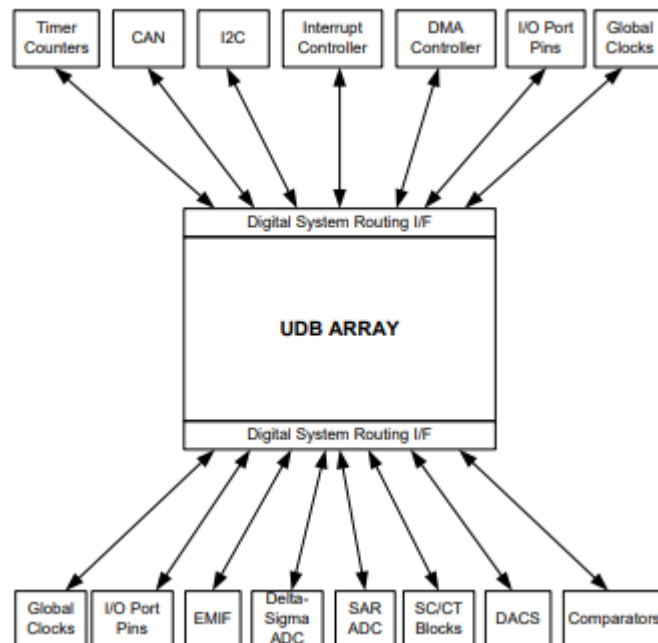

32. Cypress's other accused PSoC products infringe in a similar way.

COUNT II
Inducement of Infringement of the '177 Patent

33. Sentient incorporates by reference the allegations set forth in the preceding paragraphs.

34. Upon information and belief, Cypress also has indirectly infringed and is currently indirectly infringing the '177 Patent under 35 U.S.C. § 271(b) by inducing others, including its customers, to make, use, import, provide, supply, distribute, sell and offer to sell products and systems that it is aware infringe one or more claims of the '177 Patent in the United States generally, and in Texas and within this judicial district in particular.

35. On information and belief, Cypress has intentionally induced infringement, or at least has been willfully blind to infringement of the '177 Patent, by its customers since at least the service date of this complaint.

36. Cypress has proceeded in this manner despite its actual knowledge of the '177 Patent and that the specific actions it actively induced on the part of its customers and other third parties constitute infringement of the '177 Patent, at least as of the date of filing of Sentient's original Complaint. At the very least, because Cypress has been and remains on notice of the '177 Patent and the accused infringement, it has been and remains willfully blind regarding the infringement it has induced and continues to induce.

37. By way of example, Cypress provides use instructions and product literature to its customers that induce infringement of the '177 Patent.

38. On information and belief, Cypress intended to induce patent infringement by third-party customers and users of the Cypress '177 Products and had knowledge that the inducing acts

would cause infringement or was willfully blind to the possibility that its inducing acts would cause infringement, for example in its Development Kit. Cypress was aware that the normal and customary use of the accused products would infringe the '177 Patent. Cypress performed the acts that constitute induced infringement, and would induce actual infringement, with knowledge of the '177 Patent and with the knowledge that the induced acts would constitute infringement. For example, Cypress provides the Cypress '177 Products which have the capability of operating in a manner that infringe one or more of the claims of the '177 Patent, including at least claim 1, and Cypress further provides documentation and training materials that cause customers and end users of the Cypress '177 Products to utilize the products in a manner that directly infringe one or more claims of the '177 Patent. By providing instructions and training to customers and end-users on how to use the Cypress '177 Products in a manner that directly infringes one or more claims of the '177 Patent, including at least claim 1, Cypress specifically intended to induce infringement of the '177 Patent. On information and belief, Cypress engaged in such inducement to promote the sales of the Cypress '177 Products, *e.g.*, through Cypress's for example in its Development Kit and related materials, user manuals, product support, marketing materials, and training materials to actively induce the users of the accused products to infringe the '177 Patent. Accordingly, Cypress has induced and continues to induce users of the accused products to use the accused products in their ordinary and customary way to infringe the '177 Patent, knowing that such use constitutes infringement of the '177 Patent.

39. The '177 Patent is well-known within the industry as demonstrated by multiple citations to the '177 Patent in published patents and patent applications assigned to technology companies and academic institutions as well as previous infringement litigations in Eastern District of Texas against other well-known semiconductor companies. Cypress is utilizing the

technology claimed in the '177 Patent without paying a reasonable royalty. Cypress is infringing the '177 Patent in a manner best described as willful, wanton, malicious, in bad faith, deliberate, consciously wrongful, or flagrant.

40. To the extent applicable, the requirements of 35 U.S.C. § 287(a) have been met with respect to the '177 Patent.

41. As a result of Cypress's infringement of the '177 Patent, Sentient has suffered monetary damages, and seeks recovery in an amount adequate to compensate for Cypress's infringement, but in no event less than a reasonable royalty for the use made of the invention by Cypress together with interest and costs as fixed by the Court.

COUNT III
Contributory Infringement of the '177 Patent

42. Sentient incorporates by reference the allegations set forth in the preceding paragraphs.

43. Upon information and belief, Cypress also has indirectly infringed and is currently indirectly infringing the '177 Patent under 35 U.S.C. §271(c) by contributing to the infringement of others, including its customers, by making, using, importing, providing, supplying, distributing, selling, and offering to sell at least the '177 Cypress products and systems that infringe one or more claims of the '177 Patent in the United States generally, and in Delaware and in this judicial district in particular.

44. Cypress has proceeded in this manner despite its actual knowledge of the '177 Patent and that the specific actions it takes and has taken contributes to the infringement of others, including its customers and other third parties, constitute infringement of the '177 Patent, at least as of the date of filing of Sentient's original Complaint. At the very least, because

Cypress has been and remains on notice of the '177 Patent and the accused infringement, it has been and remains willfully blind regarding the infringement it has contributed to and continues to contribute to.

45. On information and belief, end users have used, and continue to use, the '177 Cypress products in an infringing manner. More specifically, Cypress sells and offers to sell infringing products to its customers that are not staple articles of commerce and that have no substantial uses outside of those that infringe the '177 Patent.

46. The acts of infringement by Cypress have caused and will continue to cause damage to Sentient in its capacity as assignee of the '177 Patent, and Sentient is entitled to recover damages from Cypress in an amount no less than a reasonable royalty pursuant to 35 U.S.C. §284. The full measure of damages sustained as a result of Cypress's wrongful acts will be proven at trial.

47. The infringement of Sentient's exclusive rights under the '177 Patent by Cypress has damaged Sentient, and unless enjoined will continue to damage Sentient, causing irreparable harm, for which there is no adequate remedy at law.

48. Upon information and belief, Cypress has infringed and continues to infringe the '177 Patent despite having knowledge of the '177 Patent and its applicability to Cypress's PSoC products.

49. Upon information and belief, Cypress's infringement of the '177 Patent has been, and continues to be, willful.

50. At least as early as the service date of this complaint, Cypress had knowledge of the '177 Patent, which is entitled to a statutory presumption of validity under 35 U.S.C. §282. Sentient intends to seek discovery on the issue of willfulness and reserves the right to seek a

willfulness finding and treble damages under 35 U.S.C. § 284, as well as its attorneys' fees and costs incurred in prosecuting this action under 35 U.S.C. § 285.

JURY DEMAND

51. Pursuant to Fed. R. Civ. P. 38, Plaintiff Sentient demands a trial by jury of any and all issues properly triable to a jury.

PRAYER FOR RELIEF

Wherefore, Sentient prays for judgment and requests that the Court find in its favor and against Cypress, and that the Court grant Sentient the following relief:

a. Judgment that one or more claims of the '177 Patent have been or are infringed, either literally or under the doctrine of equivalents, by Cypress and by others whose infringement has been induced by Cypress and to whose infringement Cypress has contributed;

b. Judgment that the '177 Patent is not invalid and is not unenforceable;

c. Preliminary and permanent injunctive relief enjoining Cypress and its officers, directors, agents, servants, affiliates, employees, divisions, branches, subsidiaries, parents, and all others acting in concert therewith from infringing, inducing infringement or, or contributing to infringement of the '177 Patent;

d. Judgment that Cypress account for and pay to Sentient all damages and costs incurred by Sentient as a result of Cypress's infringing activities under 35 U.S.C. 284, such that Sentient is adequately compensated for Cypress's infringement of the '177 Patent, but in no event less than a reasonable royalty for the use made by Cypress of the inventions claimed in the '177 Patent, including supplemental damages for any continuing post-verdict infringement up until entry of final judgment, with an accounting, as needed, and enhanced damages as provided by 35 U.S.C. 284;

- e. Pre-judgment and post-judgment interest on the damages caused by Cypress's infringing activities and other conduct complained of herein or otherwise;
- f. An award of treble damages for Cypress's willful infringement of the '177 Patent.
- g. A declaration that this is an exceptional case and an award of SS's reasonable attorneys' fees and costs in accordance with 35 U.S.C. 285 or as otherwise permitted by law;
- h. All costs of suit; and,
- i. Such other and further relief as the Court may deem just and proper under the circumstances.

Respectfully submitted,

ECKERT SEAMANS CHERIN & MELLOTT LLC

/s/ Francis G.X. Pileggi

Francis G.X. Pileggi (Bar No. 2624)
222 Delaware Avenue, 7th Floor
Wilmington, DE 19801
Telephone: 302-655-3667
Facsimile: 302-574-7401
fpileggi@eckertseamans.com

OF COUNSEL:

Michael Shanahan
Scott H. Kaliko
Kaliko & Associates, LLC
633 Wyckoff Avenue
Wyckoff, NJ 07481
Telephone: 201-739-5555
Facsimile: 201-603-1142
skaliko@kalikolaw.com

Robert W. Morris
Eckert Seamans Cherin & Mellott LLC
10 Bank Street, Suite 700
White Plains, NY 10606
Telephone: 914-286-6440
Facsimile: 914-949-5424
rwmorris@eckertseamans.com

*Attorneys for Plaintiff
Sentient Sensors, LLC*

Dated: October 31, 2019