

**IN THE UNITED STATES DISTRICT COURT
FOR THE EASTERN DISTRICT OF TEXAS
SHERMAN DIVISION**

FAR NORTH PATENTS, LLC,

Plaintiff,

v.

NEC CORPORATION,

Defendant.

CIVIL ACTION NO. 4:19-cv-943

ORIGINAL COMPLAINT FOR
PATENT INFRINGEMENT

JURY TRIAL DEMANDED

ORIGINAL COMPLAINT FOR PATENT INFRINGEMENT

Plaintiff Far North Patents, LLC (“Far North Patents” or “Plaintiff”) files this original complaint against Defendant NEC Corporation (“NEC” or “Defendant”), alleging, based on its own knowledge as to itself and its own actions and based on information and belief as to all other matters, as follows:

PARTIES

1. Far North Patents is a limited liability company formed under the laws of the State of Texas, with its principal place of business at 18383 Preston Rd Suite 250, Dallas, Texas, 75252.

2. Defendant NEC Corporation is a corporation organized and existing under the laws of Japan, with a place of business at 7-1, Shiba 5-chrome, Minato-ku, Tokyo 108-8001, Japan.

JURISDICTION AND VENUE

3. This is an action for infringement of United States patents arising under 35 U.S.C. §§ 271, 281, and 284–85, among others. This Court has subject matter jurisdiction of the action under 28 U.S.C. § 1331 and § 1338(a).

4. This Court has personal jurisdiction over NEC pursuant to due process and/or the Texas Long Arm Statute because, *inter alia*, (i) NEC has done and continues to do business in Texas; and (ii) NEC has committed and continues to commit acts of patent infringement in the State of Texas, including making, using, offering to sell, and/or selling accused products in Texas, and/or importing accused products into Texas, including by Internet sales and sales via retail and wholesale stores, inducing others to commit acts of patent infringement in Texas, and/or committing a least a portion of any other infringements alleged herein. In addition, or in the alternative, this Court has personal jurisdiction over NEC pursuant to Fed. R. Civ. P. 4(k)(2).

5. Venue is proper as to Defendant NEC Corporation, which is organized under the laws of Japan. 28 U.S.C. § 1391(c)(3) provides that “a defendant not resident in the United States may be sued in any judicial district, and the joinder of such a defendant shall be disregarded in determining where the action may be brought with respect to other defendants.”

BACKGROUND

6. The patents-in-suit generally pertain to communications networks and other technology used in the provision of wireless services, Voice over Internet Protocol (“VoIP”) phone systems, high speed networking, and other advanced communication services. The technology disclosed by the patents was developed by personnel at MCI WorldCom (“WorldCom”), Path1 Network Technologies Inc. (“Path1 Network Technologies”), Robelight LLC (“Robelight”), and BellSouth Corporation (“BellSouth”).

7. WorldCom was a leading telecommunications service provider in the late 1990s and early 2000s. Verizon acquired WorldCom in 2005. The patents developed at WorldCom (“the Hardy patents”) are related to Quality of Service (“QoS”) evaluation in telecommunications systems.

8. The inventor of the Hardy patents, former principal analyst for quality measurement and analyses at WorldCom Dr. William C. Hardy, was at the forefront of QoS in telecommunications systems. Dr. Hardy developed, disclosed, and patented a solution for efficiently and consistently evaluating QoS. In fact, Dr. Hardy literally wrote the book on QoS in telecommunications systems. *See Hardy, William C., QoS Measurement and Evaluation of Telecommunications Quality of Service (Wiley 2001).*

9. Dr. Hardy has received considerable praise for his work in QoS. Luis Sousa Cardoso, Quality of Service Development Group Chairman, left little doubt regarding the esteem with which he holds Dr. Hardy: “William C. ‘Chris’ Hardy is unquestionably among the leading lights in the field of QoS[.]” Dr. Hardy’s book was reviewed in *IEEE Communications Magazine*, Vol. 40, No. 2, Feb. 2002, which stated that the book “provides a straightforward and very accessible approach to measurement and evaluation of QoS in telecommunications networks...strongly recommended for all people, either experiences professionals or graduates, involved in the area of networking[.]” He is even an honorary member of the Russian Academy of Science.

10. The Hardy patents (or the applications leading to them) have been cited during patent prosecution hundreds of times, by numerous leading companies in the computer networking and telecommunications industries industry, including Adtran, Alcatel-Lucent, Arris, AT&T, Avaya, Cisco, Deutsche Telekom (T-Mobile), Dolby Laboratories Licensing Corporation, Empirix, Ericsson, Genband, General Electric, IBM, Juniper, Microsoft, Motorola, NEC, Oracle, Panasonic, Ringcentral, Sharp, Siemens, Sprint, USAA, and Verizon.

11. Path1 Network Technologies is a provider of video over IP services and solutions. The patents developed at Path1 Network Technologies (“the Fellman patents”) relate to

providing service guarantees for time sensitive signals in computer networks. The inventors of these patents include Dr. Ronald D. Fellman and Dr. Rene L. Cruz. Drs. Fellman and Cruz, both former professors of electrical and computer engineering at the University of California at San Diego, were pioneers in network technology. Dr. Fellman was an IEEE Senior Member, and his work was published in several IEEE Transactions journals, including IEEE Transactions on Networking, IEEE Transactions on Parallel and Distributed Systems, IEEE Transactions on Systems, Man, and Cybernetics, IEEE Transactions on Signal Processing, IEEE Transactions on Very Large Scale Integration (VLSI) Systems, IEEE Transactions on Acoustics, Speech and Signal Processing. He was also a co-founder of Path1 Network Technologies and of Qvidium Technologies. Dr. Cruz, a distinguished scholar in the field of communication networks, was said to have established the field of Network Calculus. In Dr. Cruz's election to be a Fellow of the IEEE in 2003, he was "cited for his expertise in the area of Quality-of-Service guarantees in packet-switched networks."

http://jacobsschool.ucsd.edu/news/news_releases/release.sfe?id=1385.

12. The Fellman patents (or the applications leading to them) have been cited during patent prosecution hundreds of times, by numerous leading companies in the computer networking and telecommunications industries, including ABB Research, AMD, Amazon, AT&T, Atheros Communications, Avaya, Bose, Broadcom, Canon, Centurylink, Chi Mei Optoelectronics, Ciena, Cox Communications, Dell, F5 Networks, Fujitsu, Hitachi, Honeywell, Intel, IBM, Lucent, Lutron, Microsoft, National Instruments, National Semiconductor, NEC, Nortel Networks, Oceaneering, Phillips, Qualcomm, Robert Bosch, Samsung, Siemens, Sonos, Sony, Symantec, Texas Instruments, Toshiba, Ubiquiti Networks, Verizon, and Viasat.

13. The patents developed at Robelight (“the Light patents”) relate to obtaining presence information over a network. Inventors Elliot D. Light and Jon L. Roberts are named inventors on over 30 patents combined. The Light patents (or the applications leading to them) have been cited during patent prosecution over a hundred times, by numerous leading companies in the computer networking and telecommunications industries, including Alcatel-Lucent, Apple, AT&T, Avaya, Google, LG Electronics, Nortel Networks, Qualcomm, Rockstar Consortium, SAP, Shoretel, Vonage, and ZTE.

14. BellSouth, founded in 1983 as one of the seven original Regional Bell Operating Companies after the breakup of AT&T, was a giant in the telecommunications industry. BellSouth was active in both broadband and wireless, operating in the southern United States as well as in Argentina, Australia, Chile, Colombia, Ecuador, Guatemala, New Zealand, Nicaragua, Panama, Peru, Uruguay, and Venezuela. BellSouth was acquired by AT&T in 2006 for approximately \$86 billion.

15. The patents developed at BellSouth (“the Easley patents”) relate to providing a calling name service for mobile phones. Larry Scott Easley, the inventor of the Easley patents, was a prolific inventor for BellSouth—he was a named inventor on ten United States Patents. The Easley patents (or the applications leading to them) have been cited during patent prosecution over a hundred times, by numerous leading companies in the computer networking and telecommunications industries, including Alcatel-Lucent, AT&T, Ericsson, Genesys, Lucent, Nortel Networks, Siemens, Sprint, and Sybase 365.

COUNT I

DIRECT INFRINGEMENT OF U.S. PATENT NO. 8,689,105

16. On April 1, 2014, United States Patent No. 8,689,105 (“the ‘105 Patent”) was duly and legally issued by the United States Patent and Trademark Office for an invention entitled “Real-Time Monitoring of Perceived Quality of Packet Voice Transmission.”

17. Far North Patents is the owner of the ‘105 Patent, with all substantive rights in and to that patent, including the sole and exclusive right to prosecute this action and enforce the ‘105 Patent against infringers, and to collect damages for all relevant times.

18. NEC made, had made, used, imported, provided, supplied, distributed, sold, and/or offered for sale products and/or systems including, for example, its NEC Integrated network management system MS5000 family of products that include advanced quality monitoring capabilities (collectively, “accused products”).

Integrated Network Management System(MS5000)

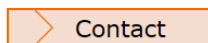

The MS5000 integrated network management system unifies and manages NEC transport nodes (optical, radio, and IP) in your networks. MS5000 enables seamless management of all NEC optical transport products including a submarine cable transmission product to provide a single NEC transport solution.

 Contact

(Source : <https://www.nec.com/en/global/solutions/nsp/oam/index.html>)

NEC's Integrated network management system MS5000 provides end-to-end seamless view of entire network through managing the State management and the configuration management, enabling a full range of fault and performance management functions.

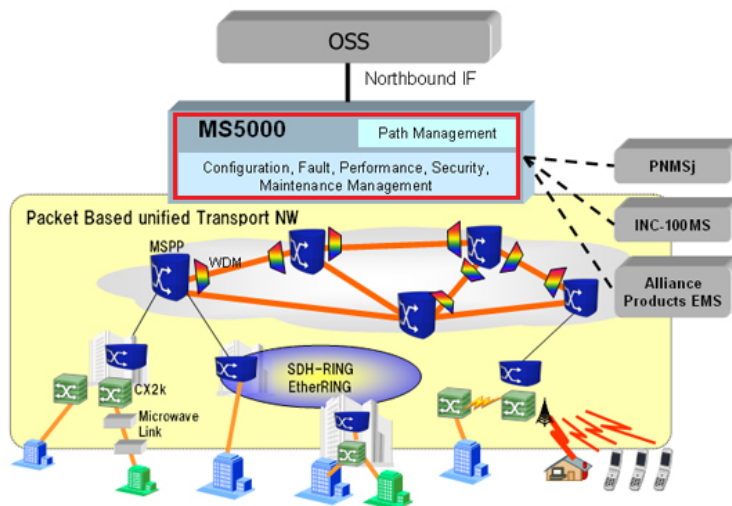

(Source : <https://www.nec.com/en/global/solutions/nsp/nms/index.html>)

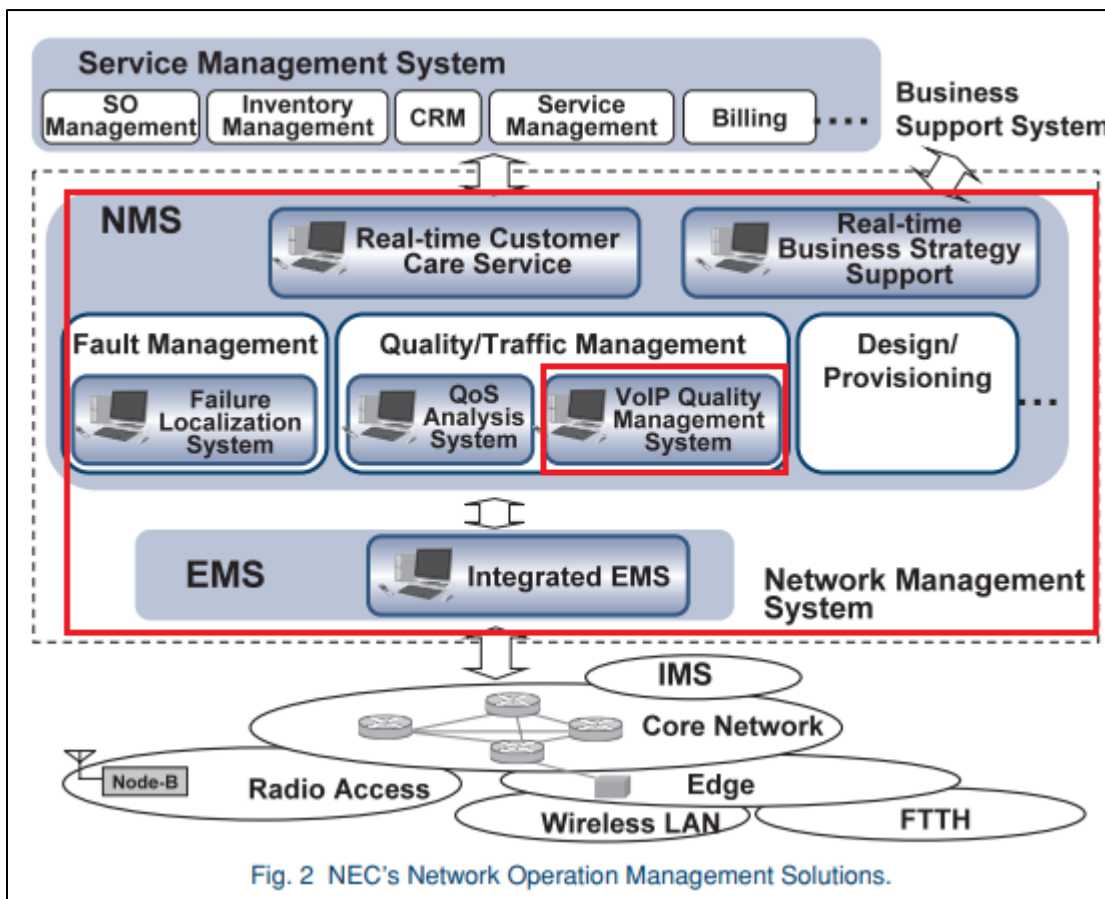

Fig. 2 NEC's Network Operation Management Solutions.

(Source : <https://www.nec.com/en/global/techrep/journal/g06/n02/pdf/t060211.pdf>)

(2) VoIP Quality Measurement System

This system uses an active measurement method which exchanges pseudo RTP calls between probes in order measure the voice quality (R Factor, etc.) of the VoIP services based on the e-model as defined in ITU-T-G.107. These measurements are performed periodically and the collected quality data is stored in the server to enable management of the voice quality status of the network.

(Source : <https://www.nec.com/en/global/techrep/journal/g06/n02/pdf/t060211.pdf>)

19. By doing so, NEC has directly infringed (literally and/or under the doctrine of equivalents) at least Claims 1 and 23 of the ‘105 Patent. NEC’s infringement in this regard is ongoing.

20. NEC has infringed the ‘105 Patent by using the accused products and thereby practicing a method that includes obtaining, by a network device, a reference matrix based on estimates of perceived audio quality of at least portions of one or more first packetized audio messages, the reference matrix modeling values of a plurality of characteristics associated with a particular quality level. For example, the accused products are used by NEC to implement the ITU-T G.107 Recommendation. The quality of audio in VoIP networks (packet switched networks) are calculated using MOS (Mean Opinion score) values according to ITU-T G.107 Recommendation E-model. The E-model computes a transmission rating value R, which is a combinational effect of all the transmission parameters in an audio conversation. The E-model uses a reference table (“reference matrix”) based on the estimates of perceived audio conversational/audio quality. The reference table includes modelling values like MOS-CQE (Mean Opinion Score – Estimated Conversational Quality), each associated with a quality level.

7 Target services

This Recommendation gives guidelines for QoE assessment of various telecommunication services mainly utilizing audio and visual media.

7.1 Audio

- Conversational voice and voice messaging

Speech communication services such as mobile telephony and voice over Internet protocol (VoIP), as well as conventional public switched telephone network (PSTN) and integrated services digital network (ISDN) services, are important targets of this Recommendation. The speech bandwidth can be either narrowband (NB) (300-3400 Hz) or wideband (WB) (100-7000 Hz).

(Source: https://www.itu.int/rec/dologin_pub.asp?lang=e&id=T-REC-G.1011-201506-S!!PDF-E&type=items)

8.5 Planning models

The input for planning models (Figure 8-5) includes the quality planning parameters of networks or terminals. It usually requires prior knowledge about the system under test. Such models can be applied to network planning and terminal/application design.

G.1011(10)_FB-5

Figure 8-5 – Planning model

Standard examples of such models are [ITU-T G.107] for speech and [ITU-T G.1070] for videophone.

(Source: https://www.itu.int/rec/dologin_pub.asp?lang=e&id=T-REC-G.1011-201506-S!!PDF-E&type=items)

Recommendation ITU-T G.107

The E-model: a computational model for use in transmission planning

1 Scope

This Recommendation describes a computational model, known as the E-model, that has proven useful as a transmission planning tool for assessing the combined effects of variations in several transmission parameters that affect conversational¹ quality of 3.1 kHz handset telephony. This computational model can be used, for example, by transmission planners to help ensure that users will be satisfied with end-to-end transmission performance whilst avoiding over-engineering of networks. It must be emphasized that the primary output from the model is the "rating factor" R but this can be transformed to give estimates of customer opinion. Such estimates are only made for transmission planning purposes and not for actual customer opinion prediction (for which there is no agreed-upon model recommended by the ITU-T).

(Source: https://www.itu.int/rec/dologin_pub.asp?lang=s&id=T-REC-G.107-201402-S!!PDF-E&type=items)

7 Structure and basic algorithms of the E-model

The E-model is based on the equipment impairment factor method, following previous transmission rating models. It was developed by an ETSI ad hoc group called "Voice Transmission Quality from Mouth to Ear".

The reference connection, as shown in Figure 1, is split into a send side and a receive side. The model estimates the conversational quality from mouth to ear as perceived by the user at the receive side, both as listener and talker.

(Source: https://www.itu.int/rec/dologin_pub.asp?lang=s&id=T-REC-G.107-201402-S!!PDF-E&type=items)

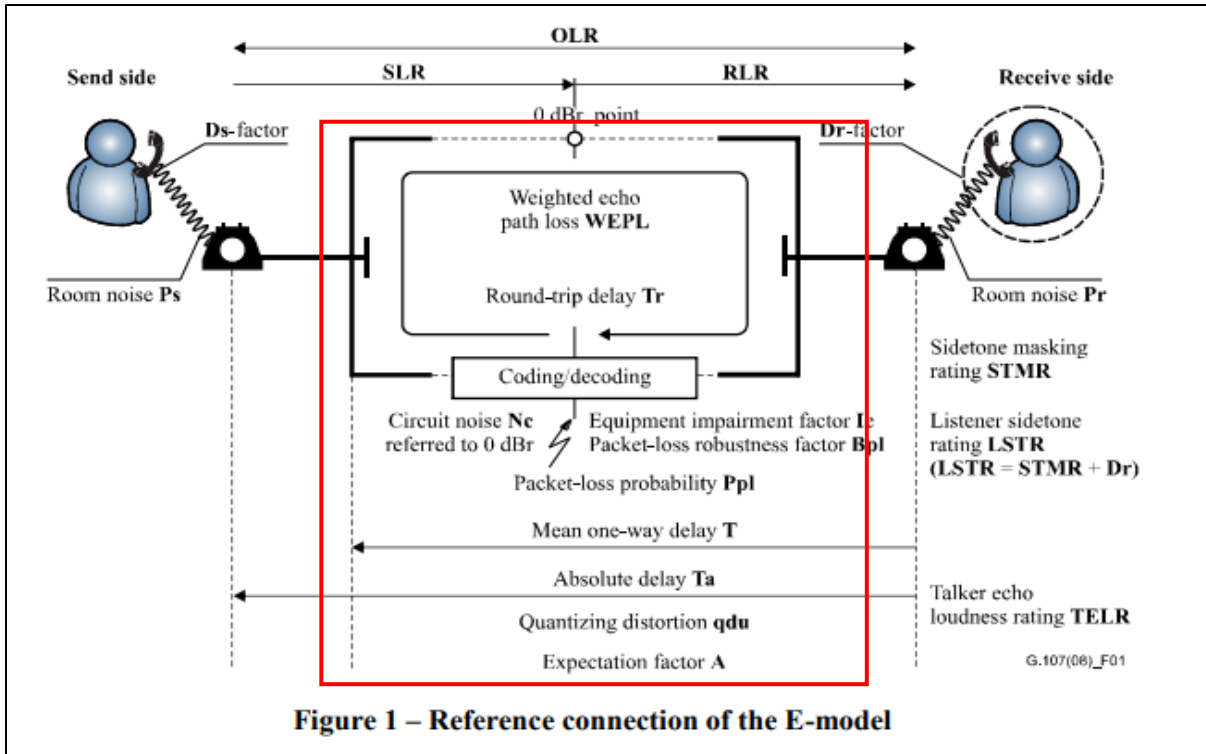

Figure 1 – Reference connection of the E-model

(Source: https://www.itu.int/rec/dologin_pub.asp?lang=s&id=T-REC-G.107-201402-S!!PDF-E&type=items)

7.1 Calculation of the transmission rating factor, R

According to the equipment impairment factor method, the fundamental principle of the E-model is based on a concept given in the description of the OPINE model (see [b-ITU-T P-Sup.3]).

Psychological factors on the psychological scale are additive.

The result of any calculation with the E-model in a first step is a transmission rating factor R , which combines all transmission parameters relevant for the considered connection. This rating factor R is composed of:

$$R = R_o - I_s - I_d - I_{e-eff} + A \quad (7-1)$$

R_o represents in principle the basic signal-to-noise ratio, including noise sources such as circuit noise and room noise. Factor I_s is a combination of all impairments which occur more or less simultaneously with the voice signal. Factor I_d represents the impairments caused by delay and the effective equipment impairment factor I_{e-eff} represents impairments caused by low bit-rate codecs. It also includes impairment due to randomly distributed packet losses. The advantage factor A allows for compensation of impairment factors when the user benefits from other types of access to the user. The term R_o and the I_s and I_d values are subdivided into further specific impairment values. The following clauses give the equations used in the E-model.

(Source: https://www.itu.int/rec/dologin_pub.asp?lang=s&id=T-REC-G.107-201402-S!!PDF-E&type=items)

An estimated mean opinion score (MOS_{CQE}) for the conversational situation in the scale 1-5 can be obtained from the R -factor using the equations:

$$\text{For } R < 0: \quad MOS_{CQE} = 1$$

$$\text{For } 0 < R < 100: \quad MOS_{CQE} = 1 + 0.035R + R(R - 60)(100 - R)7 \cdot 10^{-6} \quad (\text{B-4})$$

$$\text{For } R > 100: \quad MOS_{CQE} = 4.5$$

(Source: https://www.itu.int/rec/dologin_pub.asp?lang=s&id=T-REC-G.107-201402-S!!PDF-E&type=items)

In some cases, transmission planners may not be familiar with the use of quality measures such as the R rating factor obtained from planning calculations, and thus provisional guidance for interpreting calculated R factors for planning purposes is given in Table B.1³. This table also contains equivalent transformed values of R into estimated conversational MOS_{CQE} , GoB and PoW.

Table B.1 – Provisional guide for the relation between R -value and user satisfaction

R -value (lower limit)	MOS_{CQE} (lower limit)	GoB (%) (lower limit)	PoW (%) (upper limit)	User satisfaction
90	4.34	97	~0	Very satisfied
80	4.03	89	~0	Satisfied
70	3.60	73	6	Some users dissatisfied
60	3.10	50	17	Many users dissatisfied
50	2.58	27	38	Nearly all users dissatisfied

(Source: https://www.itu.int/rec/dologin_pub.asp?lang=s&id=T-REC-G.107-201402-S!!PDF-E&type=items)

7.2.3 MOS-CQE

The score is calculated by a network planning model which aims at predicting the quality in a conversational application situation. Estimates of conversational quality carried out according to [ITU-T G.107], when transformed to mean opinion score, give results in terms of MOS-CQE.

(Source: https://www.itu.int/rec/dologin_pub.asp?lang=e&id=T-REC-P.800.1-201607-1!!PDF-E&type=items)

21. The methods practiced by NEC's use of the accused products include receiving, by the network device, one or more second packetized audio messages and evaluating, by the network device, at least portions of one or more of the one or more second packetized audio

messages to obtain measurements associated with the plurality of characteristics. For example, the accused products are used by NEC to implement the ITU-T G.107 Recommendation. The E-model is applied to a real-time voice call (“second packetized audio messages”) for measuring its voice quality by calculating the R value. The R value can be converted into a MOS value. The R value represents the combinational effect of all transmission parameters in an audio conversation. The E-Model estimates the MOS-CQE/audio quality of the speech signals.

7.1 Calculation of the transmission rating factor, R

According to the equipment impairment factor method, the fundamental principle of the E-model is based on a concept given in the description of the OPINE model (see [b-ITU-T P-Sup.3]).

Psychological factors on the psychological scale are additive.

The result of any calculation with the E-model in a first step is a transmission rating factor R , which combines all transmission parameters relevant for the considered connection. This rating factor R is composed of:

$$R = R_o - I_s - I_d - I_{e-eff} + A \quad (7-1)$$

R_o represents in principle the basic signal-to-noise ratio, including noise sources such as circuit noise and room noise. Factor I_s is a combination of all impairments which occur more or less simultaneously with the voice signal. Factor I_d represents the impairments caused by delay and the effective equipment impairment factor I_{e-eff} represents impairments caused by low bit-rate codecs. It also includes impairment due to randomly distributed packet losses. The advantage factor A allows for compensation of impairment factors when the user benefits from other types of access to the user. The term R_o and the I_s and I_d values are subdivided into further specific impairment values. The following clauses give the equations used in the E-model.

(Source: https://www.itu.int/rec/dologin_pub.asp?lang=s&id=T-REC-G.107-201402-S!!PDF-E&type=items)

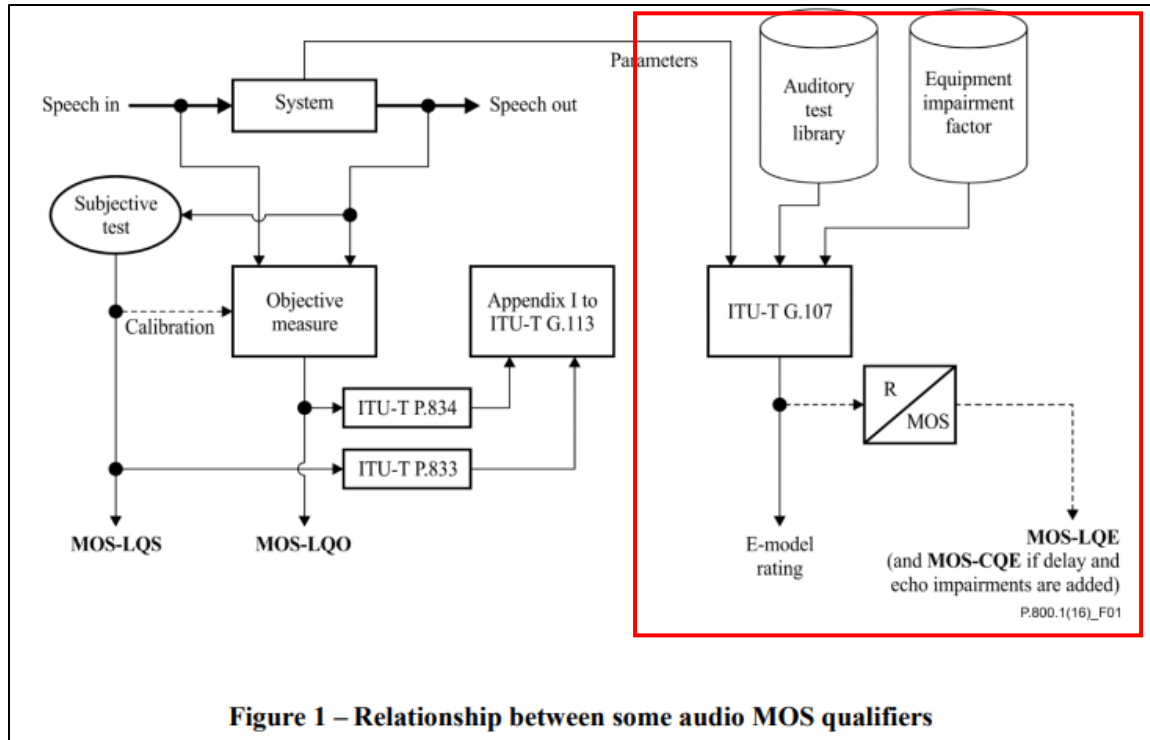

(Source: https://www.itu.int/rec/dologin_pub.asp?lang=e&id=T-REC-P.800.1-201607-I!!PDF-E&type=items)

22. The methods practiced by NEC's use of the accused products include creating, by the network device, a test matrix using the obtained measurements and comparing, by the network device, the test matrix and the reference matrix to predict a quality level associated with the one or more second packetized audio messages. For example, the accused products are used by NEC to implement the ITU-T G.107 Recommendation. ITU-T G.107 E-Model estimates MOS-CQE/audio quality of the speech signals. The test speech signal parameters are input to the G.107 E-Model for calculating the R and MOS values. The calculated R/MOS value ("test matrix") is then compared with the reference table ("reference matrix") for determining the perceived audio quality. For example, a comparison is performed between estimated MOS value and existing reference values to determine the perceived audio quality of the test speech. For instance, a MOS value of 4.5 and a R value of 95 is compared with each row of the reference

table and a perceived voice quality is determined accordingly, which is Best/Very satisfied in this case.

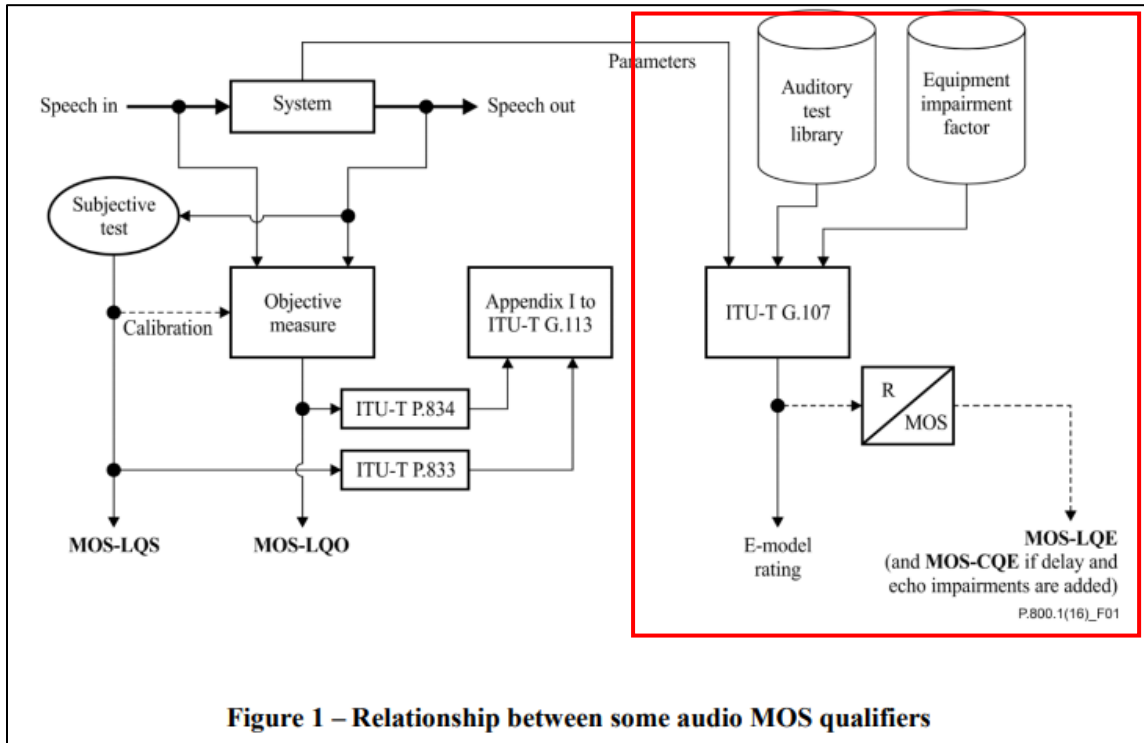

Figure 1 – Relationship between some audio MOS qualifiers

(Source: https://www.itu.int/rec/dologin_pub.asp?lang=e&id=T-REC-P.800.1-201607-I!!PDF-E&type=items)

7.1 Calculation of the transmission rating factor, R

According to the equipment impairment factor method, the fundamental principle of the E-model is based on a concept given in the description of the OPINE model (see [b-ITU-T P-Sup.3]).

Psychological factors on the psychological scale are additive.

The result of any calculation with the E-model in a first step is a transmission rating factor *R*, which combines all transmission parameters relevant for the considered connection. This rating factor *R* is composed of:

$$R = R_o - I_s - I_d - I_{e-eff} + A \quad (7-1)$$

R_o represents in principle the basic signal-to-noise ratio, including noise sources such as circuit noise and room noise. Factor *I_s* is a combination of all impairments which occur more or less simultaneously with the voice signal. Factor *I_d* represents the impairments caused by delay and the effective equipment impairment factor *I_{e-eff}* represents impairments caused by low bit-rate codecs. It also includes impairment due to randomly distributed packet losses. The advantage factor *A* allows for compensation of impairment factors when the user benefits from other types of access to the user. The term *R_o* and the *I_s* and *I_d* values are subdivided into further specific impairment values. The following clauses give the equations used in the E-model.

(Source: https://www.itu.int/rec/dologin_pub.asp?lang=s&id=T-REC-G.107-201402-S!!PDF-E&type=items)

In some cases, transmission planners may not be familiar with the use of quality measures such as the *R* rating factor obtained from planning calculations, and thus provisional guidance for interpreting calculated *R* factors for planning purposes is given in Table B.1³. This table also contains equivalent transformed values of *R* into estimated conversational MOS_{CQE}, GoB and PoW.

Table B.1 – Provisional guide for the relation between *R*-value and user satisfaction

<i>R</i> -value (lower limit)	MOS _{CQE} (lower limit)	GoB (%) (lower limit)	PoW (%) (upper limit)	User satisfaction
90	4.34	97	~0	Very satisfied
80	4.03	89	~0	Satisfied
70	3.60	73	6	Some users dissatisfied
60	3.10	50	17	Many users dissatisfied
50	2.58	27	38	Nearly all users dissatisfied

(Source: https://www.itu.int/rec/dologin_pub.asp?lang=s&id=T-REC-G.107-201402-S!!PDF-E&type=items)

Table 1 - Definition of categories of speech transmission quality

Range of E-model Rating <i>R</i>	Speech transmission quality category	User satisfaction
90 ≤ <i>R</i> < 100	Best	Very satisfied
80 ≤ <i>R</i> < 90	High	Satisfied
70 ≤ <i>R</i> < 80	Medium	Some users dissatisfied
60 ≤ <i>R</i> < 70	Low	Many users dissatisfied
50 ≤ <i>R</i> < 60	Poor	Nearly all users dissatisfied

NOTE 1 – Connections with E-model Ratings *R* below 50 are not recommended.
 NOTE 2 – Although the trend in transmission planning is to use E-model Ratings *R*, equations to convert E-model Ratings *R* into other metrics, e.g. %MOS, %GoB, PoW can be found in **ITU-T Rec. G.107 Annex B [1]**.

(Source: <https://www.itu.int/ITU-T/studygroups/com12/emodelv1/tut.htm>)

23. NEC has infringed the ‘105 Patent by making, having made, using, importing, providing, supplying, distributing, selling or offering for sale products including the claimed non-transitory computer-readable medium having instructions stored thereon configured to cause a computing device to perform operations, and those operations including obtaining a reference matrix based on estimates of perceived audio quality of at least portions of one or more first packetized audio messages, the reference matrix modeling values of a plurality of characteristics associated with a particular quality level. For example, the accused products are configured to

be used to implement the ITU-T G.107 Recommendation. The quality of audio in VoIP networks (packet switched networks) is calculated using MOS (Mean Opinion score) values according to ITU-T G.107 Recommendation E-model. The E-model computes a transmission rating value R, which is a combinational effect of all the transmission parameters in an audio conversation. The E-model uses a reference table (“reference matrix”) based on the estimates of perceived audio conversational/audio quality. The reference table includes modelling values like MOS-CQE (Mean Opinion Score – Estimated Conversational Quality), each associated with a quality level.

7 Target services

This Recommendation gives guidelines for QoE assessment of various telecommunication services mainly utilizing audio and visual media.

7.1 Audio

– Conversational voice and voice messaging

Speech communication services such as mobile telephony and voice over Internet protocol (VoIP), as well as conventional public switched telephone network (PSTN) and integrated services digital network (ISDN) services, are important targets of this Recommendation. The speech bandwidth can be either narrowband (NB) (300-3400 Hz) or wideband (WB) (100-7000 Hz).

(Source: https://www.itu.int/rec/dologin_pub.asp?lang=e&id=T-REC-G.1011-201506-S!!PDF-E&type=items)

8.5 Planning models

The input for planning models (Figure 8-5) includes the quality planning parameters of networks or terminals. It usually requires prior knowledge about the system under test. Such models can be applied to network planning and terminal/application design.

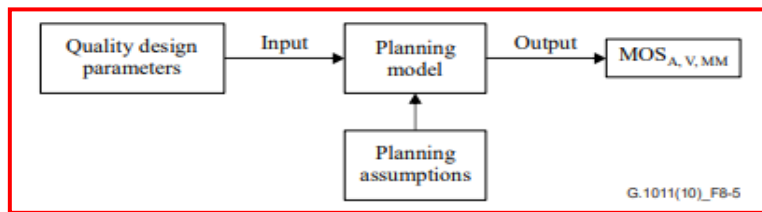

Figure 8-5 – Planning model

Standard examples of such models are [ITU-T G.107] for speech and [ITU-T G.1070] for videophone.

(Source: https://www.itu.int/rec/dologin_pub.asp?lang=e&id=T-REC-G.1011-201506-S!!PDF-E&type=items)

Recommendation ITU-T G.107

The E-model: a computational model for use in transmission planning

1 Scope

This Recommendation describes a computational model, known as the E-model, that has proven useful as a transmission planning tool for assessing the combined effects of variations in several transmission parameters that affect conversational¹ quality of 3.1 kHz handset telephony. This computational model can be used, for example, by transmission planners to help ensure that users will be satisfied with end-to-end transmission performance whilst avoiding over-engineering of networks. It must be emphasized that the primary output from the model is the "rating factor" *R* but this can be transformed to give estimates of customer opinion. Such estimates are only made for transmission planning purposes and not for actual customer opinion prediction (for which there is no agreed-upon model recommended by the ITU-T).

(Source: https://www.itu.int/rec/dologin_pub.asp?lang=s&id=T-REC-G.107-201402-S!!PDF-E&type=items)

7 Structure and basic algorithms of the E-model

The E-model is based on the equipment impairment factor method, following previous transmission rating models. It was developed by an ETSI ad hoc group called "Voice Transmission Quality from Mouth to Ear".

The reference connection, as shown in Figure 1, is split into a send side and a receive side. The model estimates the conversational quality from mouth to ear as perceived by the user at the receive side, both as listener and talker.

(Source: https://www.itu.int/rec/dologin_pub.asp?lang=s&id=T-REC-G.107-201402-S!!PDF-E&type=items)

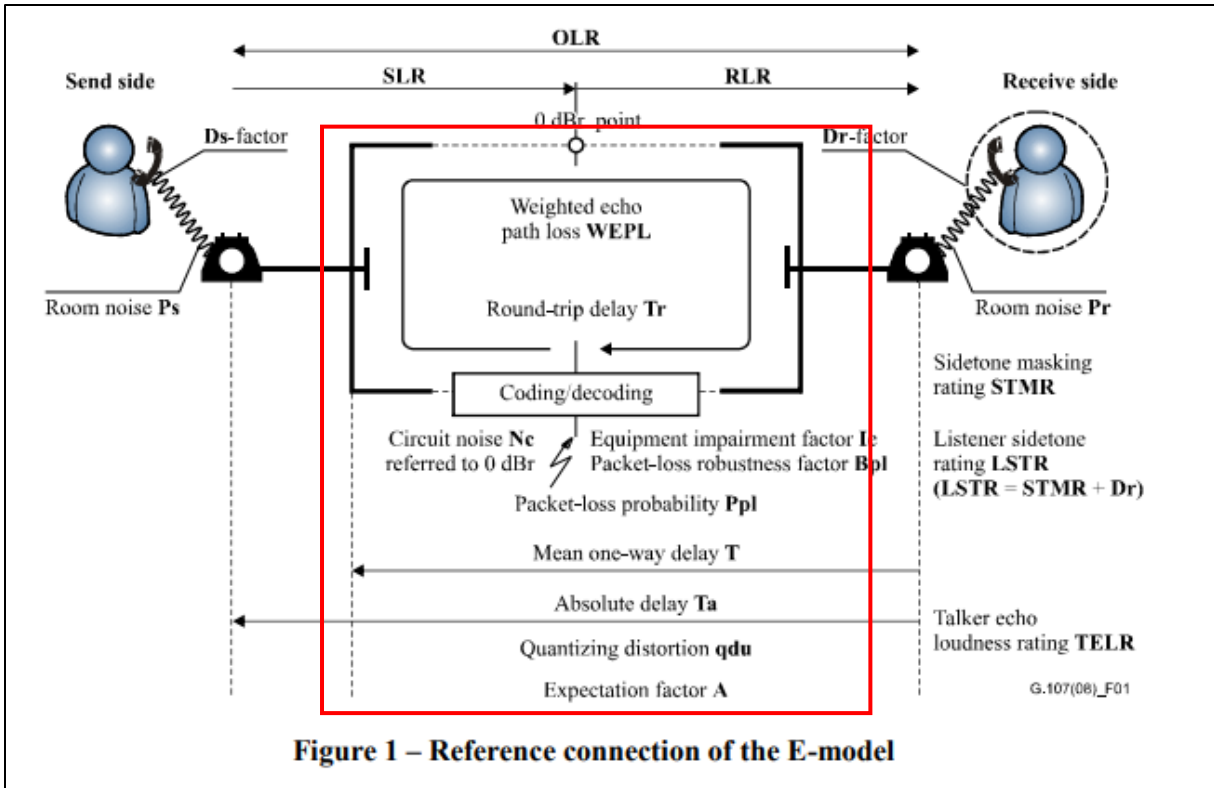

Figure 1 – Reference connection of the E-model

(Source: https://www.itu.int/rec/dologin_pub.asp?lang=s&id=T-REC-G.107-201402-S!!PDF-E&type=items)

7.1 Calculation of the transmission rating factor, R

According to the equipment impairment factor method, the fundamental principle of the E-model is based on a concept given in the description of the OPINE model (see [b-ITU-T P-Sup.3]).

Psychological factors on the psychological scale are additive.

The result of any calculation with the E-model in a first step is a transmission rating factor R , which combines all transmission parameters relevant for the considered connection. This rating factor R is composed of:

$$R = R_o - I_s - I_d - I_{e-eff} + A \quad (7-1)$$

R_o represents in principle the basic signal-to-noise ratio, including noise sources such as circuit noise and room noise. Factor I_s is a combination of all impairments which occur more or less simultaneously with the voice signal. Factor I_d represents the impairments caused by delay and the effective equipment impairment factor I_{e-eff} represents impairments caused by low bit-rate codecs. It also includes impairment due to randomly distributed packet losses. The advantage factor A allows for compensation of impairment factors when the user benefits from other types of access to the user. The term R_o and the I_s and I_d values are subdivided into further specific impairment values. The following clauses give the equations used in the E-model.

(Source: https://www.itu.int/rec/dologin_pub.asp?lang=s&id=T-REC-G.107-201402-S!!PDF-E&type=items)

An estimated mean opinion score (MOS_{CQE}) for the conversational situation in the scale 1-5 can be obtained from the R -factor using the equations:

$$\text{For } R < 0: \quad MOS_{CQE} = 1$$

$$\text{For } 0 < R < 100: \quad MOS_{CQE} = 1 + 0.035R + R(R - 60)(100 - R)7 \cdot 10^{-6} \quad (\text{B-4})$$

$$\text{For } R > 100: \quad MOS_{CQE} = 4.5$$

(Source: https://www.itu.int/rec/dologin_pub.asp?lang=s&id=T-REC-G.107-201402-S!!PDF-E&type=items)

In some cases, transmission planners may not be familiar with the use of quality measures such as the R rating factor obtained from planning calculations, and thus provisional guidance for interpreting calculated R factors for planning purposes is given in Table B.1³. This table also contains equivalent transformed values of R into estimated conversational MOS_{CQE} , GoB and PoW.

Table B.1 – Provisional guide for the relation between R -value and user satisfaction

R -value (lower limit)	MOS_{CQE} (lower limit)	GoB (%) (lower limit)	PoW (%) (upper limit)	User satisfaction
90	4.34	97	~0	Very satisfied
80	4.03	89	~0	Satisfied
70	3.60	73	6	Some users dissatisfied
60	3.10	50	17	Many users dissatisfied
50	2.58	27	38	Nearly all users dissatisfied

(Source: https://www.itu.int/rec/dologin_pub.asp?lang=s&id=T-REC-G.107-201402-S!!PDF-E&type=items)

7.2.3 MOS-CQE

The score is calculated by a network planning model which aims at predicting the quality in a conversational application situation. Estimates of conversational quality carried out according to [ITU-T G.107], when transformed to mean opinion score, give results in terms of MOS-CQE.

(Source: https://www.itu.int/rec/dologin_pub.asp?lang=e&id=T-REC-P.800.1-201607-I!!PDF-E&type=items)

24. The operations performed by the accused products include creating a test matrix using measurements of at least portions of one or more second packetized audio messages associated with the plurality of characteristics and predicting a quality level associated with the

at least portions of one or more second packetized audio messages by comparing the test matrix to the reference matrix. For example, the accused products are configured to be used to implement the ITU-T G.107 Recommendation. The E-model is applied to a real-time voice call (“second packetized audio messages”) for measuring its voice quality by calculating the R value. The R value can be converted into a MOS value. The R value represents the combinational effect of all transmission parameters in an audio conversation. ITU-T G.107 E-Model estimates MOS-CQE/audio quality of the speech signals. The test speech signal parameters are input to the G.107 E model for calculating the R and MOS values. The calculated R/MOS value (“test matrix”) is then compared with the reference table (“reference matrix”) for determining the perceived audio quality. For example, a comparison is performed between estimated MOS value and existing reference values to determine the perceived audio quality of the test speech. For instance, a MOS value of 4.5 and a R value of 95 would be compared with each row of the reference table and a perceived voice quality is determined accordingly, which is Best/Very satisfied in this case.

7.1 Calculation of the transmission rating factor, R

According to the equipment impairment factor method, the fundamental principle of the E-model is based on a concept given in the description of the OPINE model (see [b-ITU-T P-Sup.3]).

Psychological factors on the psychological scale are additive.

The result of any calculation with the E-model in a first step is a transmission rating factor R , which combines all transmission parameters relevant for the considered connection. This rating factor R is composed of:

$$R = R_o - I_s - I_d - I_{e-eff} + A \quad (7-1)$$

R_o represents in principle the basic signal-to-noise ratio, including noise sources such as circuit noise and room noise. Factor I_s is a combination of all impairments which occur more or less simultaneously with the voice signal. Factor I_d represents the impairments caused by delay and the effective equipment impairment factor I_{e-eff} represents impairments caused by low bit-rate codecs. It also includes impairment due to randomly distributed packet losses. The advantage factor A allows for compensation of impairment factors when the user benefits from other types of access to the user. The term R_o and the I_s and I_d values are subdivided into further specific impairment values. The following clauses give the equations used in the E-model.

(Source: https://www.itu.int/rec/dologin_pub.asp?lang=s&id=T-REC-G.107-201402-S!!PDF-E&type=items)

An estimated mean opinion score (MOS_{CQE}) for the conversational situation in the scale 1-5 can be obtained from the R -factor using the equations:

For $R < 0$: $MOS_{CQE} = 1$

For $0 < R < 100$: $MOS_{CQE} = 1 + 0.035R + R(R - 60)(100 - R)7 \cdot 10^{-6}$ (B-4)

For $R > 100$: $MOS_{CQE} = 4.5$

(Source: https://www.itu.int/rec/dologin_pub.asp?lang=s&id=T-REC-G.107-201402-S!!PDF-E&type=items)

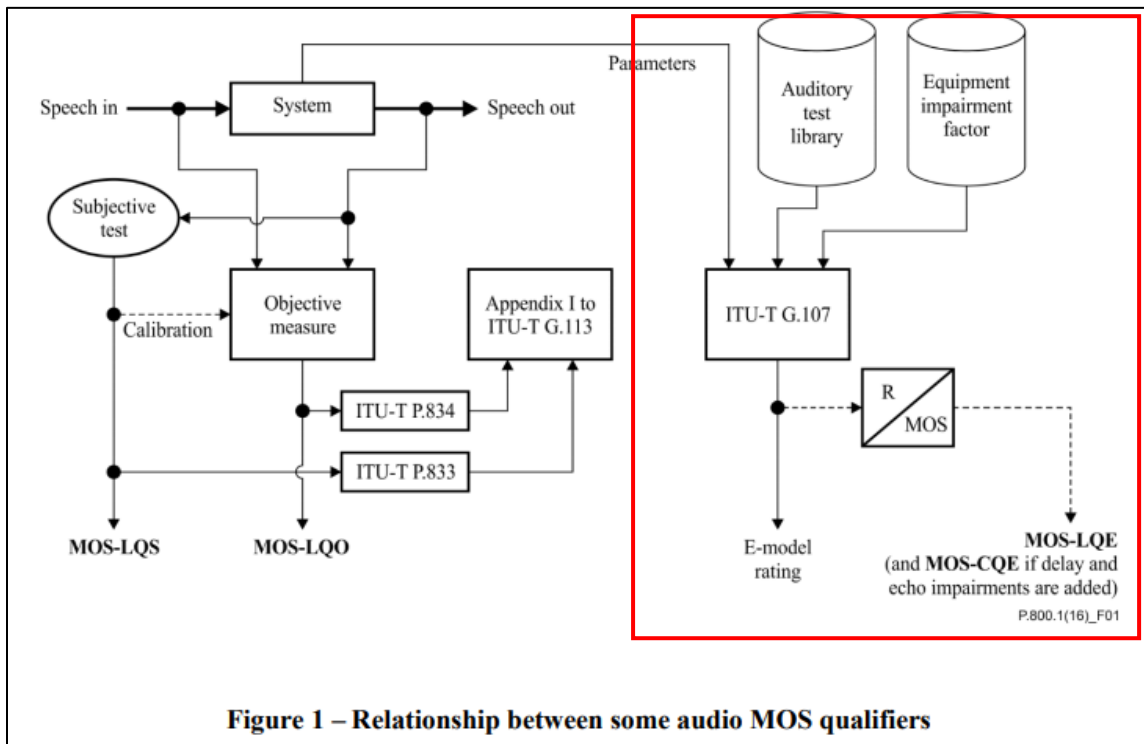

(Source: https://www.itu.int/rec/dologin_pub.asp?lang=e&id=T-REC-P.800.1-201607-I!!PDF-E&type=items)

In some cases, transmission planners may not be familiar with the use of quality measures such as the *R* rating factor obtained from planning calculations, and thus provisional guidance for interpreting calculated *R* factors for planning purposes is given in Table B.1³. This table also contains equivalent transformed values of *R* into estimated conversational MOS_{CQE}, GoB and PoW.

Table B.1 – Provisional guide for the relation between *R*-value and user satisfaction

<i>R</i> -value (lower limit)	MOS _{CQE} (lower limit)	GoB (%) (lower limit)	PoW (%) (upper limit)	User satisfaction
90	4.34	97	~0	Very satisfied
80	4.03	89	~0	Satisfied
70	3.60	73	6	Some users dissatisfied
60	3.10	50	17	Many users dissatisfied
50	2.58	27	38	Nearly all users dissatisfied

(Source: https://www.itu.int/rec/dologin_pub.asp?lang=s&id=T-REC-G.107-201402-S!!PDF-E&type=items)

Table 1 - Definition of categories of speech transmission quality

Range of E-model Rating <i>R</i>	Speech transmission quality category	User satisfaction
90 ≤ <i>R</i> < 100	Best	Very satisfied
80 ≤ <i>R</i> < 90	High	Satisfied
70 ≤ <i>R</i> < 80	Medium	Some users dissatisfied
60 ≤ <i>R</i> < 70	Low	Many users dissatisfied
50 ≤ <i>R</i> < 60	Poor	Nearly all users dissatisfied

NOTE 1 – Connections with E-model Ratings *R* below 50 are not recommended.
NOTE 2 – Although the trend in transmission planning is to use E-model Ratings *R*, equations to convert E-model Ratings *R* into other metrics, e.g. %MOS, %GoB, PoW can be found in **ITU-T Rec. G.107 Annex B [1]**.

(Source: <https://www.itu.int/ITU-T/studygroups/com12/emodelv1/tut.htm>)

25. NEC has had knowledge of the ‘105 Patent at least as of the date when it was notified of the filing of this action.

26. Far North Patents has been damaged as a result of the infringing conduct by NEC alleged above. Thus, NEC is liable to Far North Patents in an amount that adequately compensates it for such infringements, which, by law, cannot be less than a reasonable royalty, together with interest and costs as fixed by this Court under 35 U.S.C. § 284.

27. Far North Patents and/or its predecessors-in-interest have satisfied all statutory obligations required to collect pre-filing damages for the full period allowed by law for infringement of the ‘105 Patent.

COUNT II

DIRECT INFRINGEMENT OF U.S. PATENT NO. 8,068,437

28. On November 29, 2011, United States Patent No. 8,068,437 (“the ‘437 Patent”) was duly and legally issued by the United States Patent and Trademark Office for an invention entitled “Determining the Effects of New Types of Impairments on Perceived Quality of a Voice Service.”

29. Far North Patents is the owner of the ‘437 Patent, with all substantive rights in and to that patent, including the sole and exclusive right to prosecute this action and enforce the ‘437 Patent against infringers, and to collect damages for all relevant times.

30. NEC made, had made, used, imported, provided, supplied, distributed, sold, and/or offered for sale products and/or systems including, for example, its NEC Integrated network management system MS5000 family of products that include advanced quality monitoring capabilities (collectively, “accused products”).

Integrated Network Management System(MS5000)

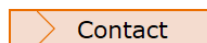

The MS5000 integrated network management system unifies and manages NEC transport nodes (optical, radio, and IP) in your networks. MS5000 enables seamless management of all NEC optical transport products including a submarine cable transmission product to provide a single NEC transport solution.

 Contact

(Source : <https://www.nec.com/en/global/solutions/nsp/oam/index.html>)

NEC's Integrated network management system MS5000 provides end-to-end seamless view of entire network through managing the State management and the configuration management, enabling a full range of fault and performance management functions.

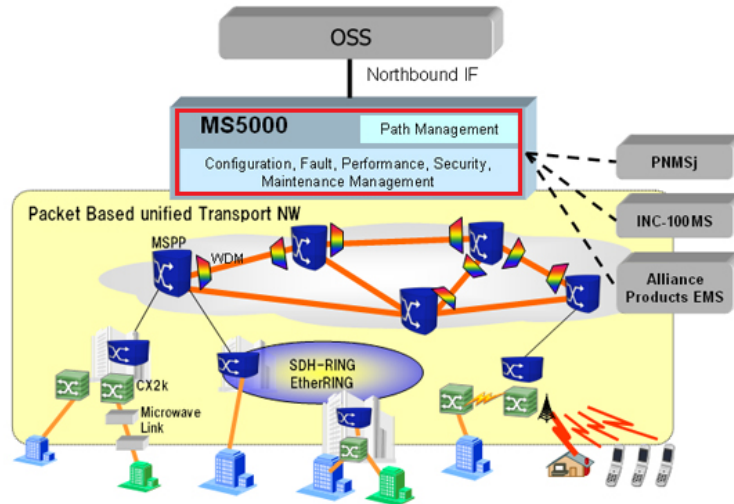

(Source : <https://www.nec.com/en/global/solutions/nsp/nms/index.html>)

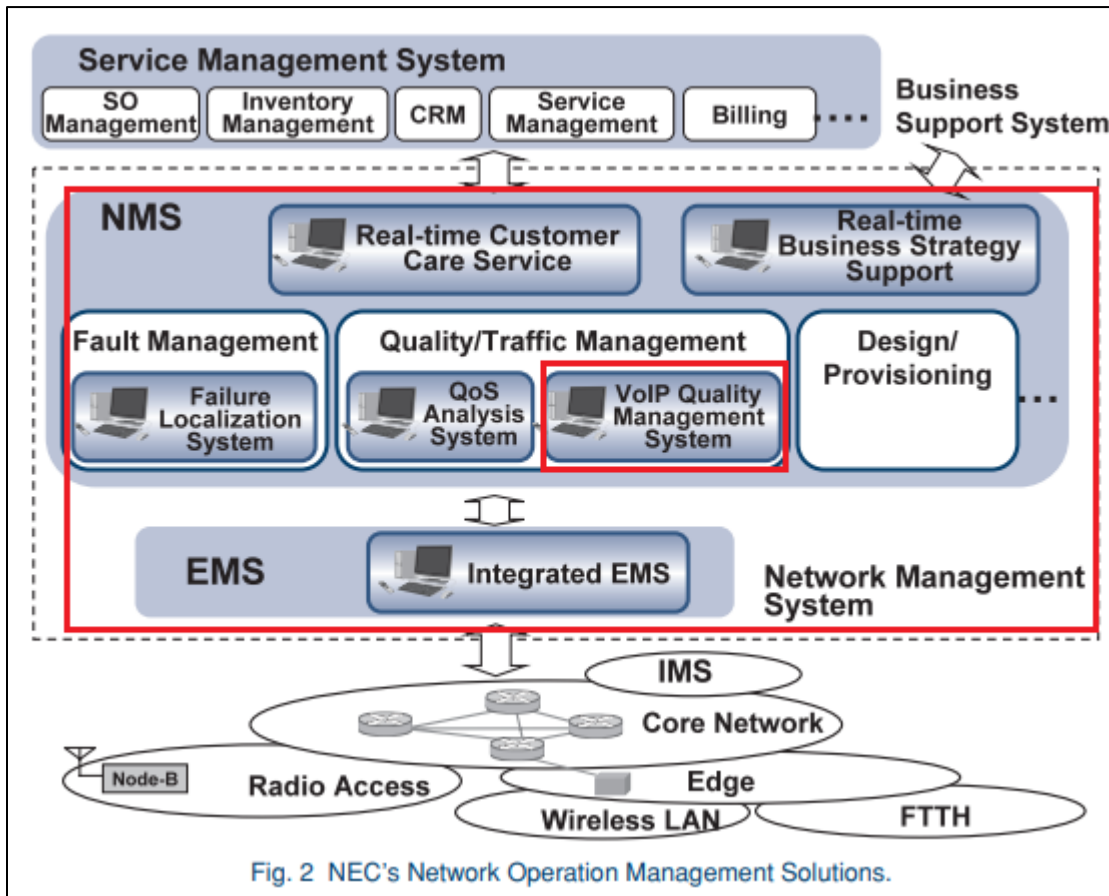

Fig. 2 NEC's Network Operation Management Solutions.

(Source : <https://www.nec.com/en/global/techrep/journal/g06/n02/pdf/t060211.pdf>)

(2) VoIP Quality Measurement System

This system uses an active measurement method which exchanges pseudo RTP calls between probes in order to measure the voice quality (R Factor, etc.) of the VoIP services based on the e-model as defined in ITU-T-G.107. These measurements are performed periodically and the collected quality data is stored in the server to enable management of the voice quality status of the network.

(Source : <https://www.nec.com/en/global/techrep/journal/g06/n02/pdf/t060211.pdf>)

31. By doing so, NEC has directly infringed (literally and/or under the doctrine of equivalents) at least Claim 9 of the '437 Patent. NEC's infringement in this regard is ongoing.

32. NEC has infringed the '437 Patent by using the accused products and thereby practicing a method performed by a computer system that includes generating, by a processor of the computer system, an assumed model for a second communication service, where the assumed model is used to transform data regarding a first performance characteristic in the second communication service to reflect effects from a second performance characteristic in the second communication service. For example, the accused products are used by NEC to implement the ITU-T G.107 Recommendation. The ITU-T G.107 Recommendation includes an E-model for calculating voice quality as perceived by a typical telephone user. The E-model outputs a transmission rating factor i.e., R, which can be transformed into Mean Opinion Score i.e., MOS value that represents the voice quality. The R value combines the effects of all relevant transmission parameters, and comprises of an effective Equipment impairment factor, $I_{e\text{-eff}}$. The E-model is applied to a real-time voice call ("second communication service") for measuring its voice quality. The effective Equipment impairment factor is calculated using a mathematical algorithm ("assumed model"). The mathematical algorithm includes an addition of two values.

The first value is an equipment impairment factor (“first performance characteristic”) at zero packet loss, or I_e . The I_e values are based on subjective MOS test results and are predefined for different codecs in ITU-T G.113 recommendation. The second value is a computation of different packet-loss-based parameters (“second performance characteristic”) namely, a packet loss robustness factor (Bpl), packet loss probability (Ppl) and a burst ratio. Thus, the computed $I_{e\text{-eff}}$ value reflects the effects of packet loss in the voice quality.

The E-model: a computational model for use in transmission planning

1 Scope

This Recommendation describes a computational model, known as the E-model, that has proven useful as a transmission planning tool for assessing the combined effects of variations in several transmission parameters that affect the conversational¹ quality of 3.1 kHz handset telephony. This computational model can be used, for example, by transmission planners to help ensure that users will be satisfied with end-to-end transmission performance whilst avoiding over-engineering of networks. It must be emphasized that the primary output from the model is the "rating factor" R but this can be transformed to give estimates of customer opinion. Such estimates are only made for transmission planning purposes and not for actual customer opinion prediction (for which there is no agreed-upon model recommended by the ITU-T).

(Source: https://www.itu.int/rec/dologin_pub.asp?lang=s&id=T-REC-G.107-201402-S!!PDF-E&type=items)

An estimated mean opinion score (MOS_{CQE}) for the conversational situation in the scale 1-5 can be obtained from the R -factor using the equations:

$$\text{For } R < 0: \quad MOS_{CQE} = 1$$

$$\text{For } 0 < R < 100: \quad MOS_{CQE} = 1 + 0.035R + R(R - 60)(100 - R)7 \cdot 10^{-6} \quad (\text{B-4})$$

$$\text{For } R > 100: \quad MOS_{CQE} = 4.5$$

(Source: https://www.itu.int/rec/dologin_pub.asp?lang=s&id=T-REC-G.107-201402-S!!PDF-E&type=items)

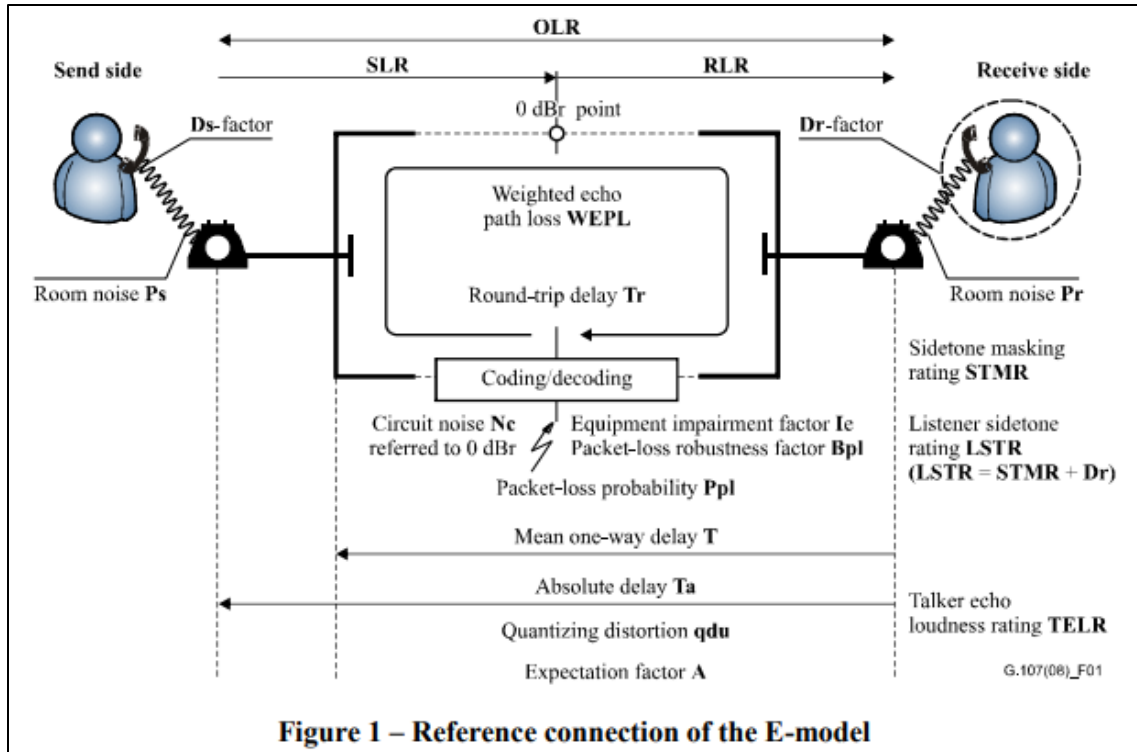

Figure 1 – Reference connection of the E-model

(Source: https://www.itu.int/rec/dologin_pub.asp?lang=s&id=T-REC-G.107-201402-S!!PDF-E&type=items)

7.1 Calculation of the transmission rating factor, R

According to the equipment impairment factor method, the fundamental principle of the E-model is based on a concept given in the description of the OPINE model, see [b-ITU-T P-Sup.3].

Psychological factors on the psychological scale are additive.

The result of any calculation with the E-model in a first step is a transmission rating factor *R*, which combines all transmission parameters relevant for the considered connection. This rating factor *R* is composed of:

$$R = R_o - I_s - I_d - I_{e-eff} + A \quad (7-1)$$

R_o represents in principle the basic signal-to-noise ratio, including noise sources such as circuit noise and room noise. Factor *I_s* is a combination of all impairments which occur more or less simultaneously with the voice signal. Factor *I_d* represents the impairments caused by delay and the effective equipment impairment factor *I_{e-eff}* represents impairments caused by low bit-rate codecs. It also includes impairment due to randomly distributed packet losses. The advantage factor *A* allows for compensation of impairment factors when the user benefits from other types of access to the user. The term *R_o* and the *I_s* and *I_d* values are subdivided into further specific impairment values. The following clauses give the equations used in the E-model.

(Source: https://www.itu.int/rec/dologin_pub.asp?lang=s&id=T-REC-G.107-201402-S!!PDF-E&type=items)

7.5 Equipment impairment factor, I_e

The values for the equipment impairment factor I_e of elements using low bit-rate codecs are not related to other input parameters. They depend on subjective mean opinion score (MOS) test results as well as on network experience. Refer to Appendix I of [ITU-T G.113] for the currently recommended values of I_e .

Specific impairment factor values for codec operation under random² packet-loss have formerly been treated using tabulated, packet-loss dependent I_e -values. Now, the packet-loss robustness factor B_{pl} is defined as a codec-specific value. The packet-loss dependent effective equipment impairment factor I_{e-eff} is derived using the codec-specific value for the equipment impairment factor at zero packet-loss I_e and the packet-loss robustness factor B_{pl} , both listed in Appendix I of [ITU-T G.113] for several codecs. With the packet-loss probability P_{pl} , I_{e-eff} is calculated using the equation:

$$I_{e-eff} = I_e + (95 - I_e) \cdot \frac{P_{pl}}{\frac{P_{pl}}{BurstR} + B_{pl}} \tag{7-29}$$

(Source: https://www.itu.int/rec/dologin_pub.asp?lang=s&id=T-REC-G.107-201402-S!!PDF-E&type=items)

This appendix provides up-to-date information on available values of the equipment impairment factor, I_e , and packet-loss robustness factor, B_{pl} , for codecs or codec families. It is intended to be updated regularly.

Table I.1 provides provisional planning values for the equipment impairment factor, I_e . These I_e values refer to non-error conditions without propagation errors, frame-erasures or packet loss. Subsequent tables deal with error and various loss conditions.

Table I.1 – Provisional planning values for the equipment impairment factor, I_e

Codec type	Reference	Operating rate [kbit/s]	I_e value
PCM (see Note)	G.711	64	0
ADPCM	G.726, G.727	40	2
	G.721, G.726, G.727	32	7
	G.726, G.727	24	25
	G.726, G.727	16	50

(Source: https://www.itu.int/rec/dologin_pub.asp?lang=e&id=T-REC-G.113-200711-I!!PDF-E&type=items)

33. The methods practiced by NEC’s use of the accused products include establishing, by the processor, a communication session via the second communication service

and obtaining, by the processor, subjective ratings of the first performance characteristic in the second communication service using the established communication session. For example, the accused products are used by NEC to implement the ITU-T G.107 Recommendation. The E-model is applied to a real-time voice call session over a system including the accused products (“second communication service”) for measuring the call’s voice quality by calculating the R value. The R value comprises of an effective Equipment impairment factor, I_{e-eff} which is calculated using various parameters like an equipment impairment factor at zero packet loss I_e (“first performance characteristic”), and other packet loss based parameters. The I_e values (“subjective ratings”) are derived from the results of subjective listening-only tests and are used as an input to the E-Model. They can be obtained from predefined values based on the implemented codec.

7.1 Calculation of the transmission rating factor, R

According to the equipment impairment factor method, the fundamental principle of the E-model is based on a concept given in the description of the OPINE model, see [b-ITU-T P-Sup.3].

Psychological factors on the psychological scale are additive.

The result of any calculation with the E-model in a first step is a transmission rating factor R , which combines all transmission parameters relevant for the considered connection. This rating factor R is composed of:

$$R = R_o - I_s - I_d - I_{e-eff} + A \quad (7-1)$$

R_o represents in principle the basic signal-to-noise ratio, including noise sources such as circuit noise and room noise. Factor I_s is a combination of all impairments which occur more or less simultaneously with the voice signal. Factor I_d represents the impairments caused by delay and the effective equipment impairment factor I_{e-eff} represents impairments caused by low bit-rate codecs. It also includes impairment due to randomly distributed packet losses. The advantage factor A allows for compensation of impairment factors when the user benefits from other types of access to the user. The term R_o and the I_s and I_d values are subdivided into further specific impairment values. The following clauses give the equations used in the E-model.

(Source: https://www.itu.int/rec/dologin_pub.asp?lang=s&id=T-REC-G.107-201402-S!!PDF-E&type=items)

7.5 Equipment impairment factor, I_e

The values for the equipment impairment factor I_e of elements using low bit-rate codecs are not related to other input parameters. They depend on subjective mean opinion score (MOS) test results as well as on network experience. Refer to Appendix I of [ITU-T G.113] for the currently recommended values of I_e .

Specific impairment factor values for codec operation under random² packet-loss have formerly been treated using tabulated, packet-loss dependent I_e -values. Now, the packet-loss robustness factor B_{pl} is defined as a codec-specific value. The packet-loss dependent effective equipment impairment factor I_{e-eff} is derived using the codec-specific value for the equipment impairment factor at zero packet-loss I_e and the packet-loss robustness factor B_{pl} , both listed in Appendix I of [ITU-T G.113] for several codecs. With the packet-loss probability P_{pl} , I_{e-eff} is calculated using the equation:

$$I_{e-eff} = I_e + (95 - I_e) \cdot \frac{P_{pl}}{\frac{P_{pl}}{BurstR} + B_{pl}} \quad (7-29)$$

(Source: https://www.itu.int/rec/dologin_pub.asp?lang=s&id=T-REC-G.107-201402-S!!PDF-E&type=items)

This appendix provides up-to-date information on available values of the equipment impairment factor, I_e , and packet-loss robustness factor, B_{pl} , for codecs or codec families. It is intended to be updated regularly.

Table I.1 provides provisional planning values for the equipment impairment factor, I_e . These I_e values refer to non-error conditions without propagation errors, frame-erasures or packet loss. Subsequent tables deal with error and various loss conditions.

Table I.1 – Provisional planning values for the equipment impairment factor, I_e

Codec type	Reference	Operating rate [kbit/s]	I_e value
PCM (see Note)	G.711	64	0
ADPCM	G.726, G.727	40	2
	G.721, G.726, G.727	32	7
	G.726, G.727	24	25
	G.726, G.727	16	50

(Source: https://www.itu.int/rec/dologin_pub.asp?lang=e&id=T-REC-G.113-200711-I!!PDF-E&type=items)

34. The methods practiced by NEC's use of the accused products include generating, by the processor, altered subjective ratings using the assumed model to reflect effects of the

second performance characteristic on the subjective ratings. For example, the accused products are used by NEC to implement the ITU-T G.107 Recommendation. The effective equipment impairment factor I_{e-eff} is calculated using a mathematical algorithm (“assumed model”). The mathematical algorithm includes an addition of two values. The first value is an equipment impairment factor (“first performance characteristic”) at zero packet loss i.e., I_e . The I_e values are based on subjective MOS test results and are predefined for different codecs in ITU-T G.113 recommendation. The second value is a computation of different packet loss (“second performance characteristic”) based parameters namely, a packet loss robustness factor (B_{pl}), packet loss probability (P_{pl}) and a burst ratio. Thus, the computed I_{e-eff} value reflects the effects of packet loss on the equipment impairment factor at zero packet loss.

7.1 Calculation of the transmission rating factor, R

According to the equipment impairment factor method, the fundamental principle of the E-model is based on a concept given in the description of the OPINE model, see [b-ITU-T P-Sup.3].

Psychological factors on the psychological scale are additive.

The result of any calculation with the E-model in a first step is a transmission rating factor R , which combines all transmission parameters relevant for the considered connection. This rating factor R is composed of:

$$R = R_o - I_s - I_d - I_{e-eff} + A \quad (7-1)$$

R_o represents in principle the basic signal-to-noise ratio, including noise sources such as circuit noise and room noise. Factor I_s is a combination of all impairments which occur more or less simultaneously with the voice signal. Factor I_d represents the impairments caused by delay and the effective equipment impairment factor I_{e-eff} represents impairments caused by low bit-rate codecs. It also includes impairment due to randomly distributed packet losses. The advantage factor A allows for compensation of impairment factors when the user benefits from other types of access to the user. The term R_o and the I_s and I_d values are subdivided into further specific impairment values. The following clauses give the equations used in the E-model.

(Source: https://www.itu.int/rec/dologin_pub.asp?lang=s&id=T-REC-G.107-201402-S!!PDF-E&type=items)

7.5 Equipment impairment factor, I_e

The values for the equipment impairment factor I_e of elements using low bit-rate codecs are not related to other input parameters. They depend on subjective mean opinion score (MOS) test results as well as on network experience. Refer to Appendix I of [ITU-T G.113] for the currently recommended values of I_e .

Specific impairment factor values for codec operation under random² packet-loss have formerly been treated using tabulated, packet-loss dependent I_e -values. Now, the packet-loss robustness factor B_{pl} is defined as a codec-specific value. The packet-loss dependent effective equipment impairment factor I_{e-eff} is derived using the codec-specific value for the equipment impairment factor at zero packet-loss I_e and the packet-loss robustness factor B_{pl} , both listed in Appendix I of [ITU-T G.113] for several codecs. With the packet-loss probability P_{pl} , I_{e-eff} is calculated using the equation:

$$I_{e-eff} = I_e + (95 - I_e) \cdot \frac{P_{pl}}{\frac{P_{pl}}{BurstR} + B_{pl}} \quad (7-29)$$

(Source: https://www.itu.int/rec/dologin_pub.asp?lang=s&id=T-REC-G.107-201402-S!!PDF-E&type=items)

This appendix provides up-to-date information on available values of the equipment impairment factor, I_e , and packet-loss robustness factor, B_{pl} , for codecs or codec families. It is intended to be updated regularly.

Table I.1 provides provisional planning values for the equipment impairment factor, I_e . These I_e values refer to non-error conditions without propagation errors, frame-erasures or packet loss. Subsequent tables deal with error and various loss conditions.

Table I.1 – Provisional planning values for the equipment impairment factor, I_e

Codec type	Reference	Operating rate [kbit/s]	I_e value
PCM (see Note)	G.711	64	0
ADPCM	G.726, G.727	40	2
	G.721, G.726, G.727	32	7
	G.726, G.727	24	25
	G.726, G.727	16	50

(Source: https://www.itu.int/rec/dologin_pub.asp?lang=e&id=T-REC-G.113-200711-I!!PDF-E&type=items)

35. The methods practiced by NEC's use of the accused products include generating, by the processor, quality index values from the altered subjective ratings. For example, the

accused products are used by NEC to implement the ITU-T G.107 Recommendation. The MOS_{CQE} values are calculated using the R values. The R value is calculated using various parameters which includes the effective equipment impairment factor I_{e-eff} (“altered subjective rating”).

7.1 Calculation of the transmission rating factor, R

According to the equipment impairment factor method, the fundamental principle of the E-model is based on a concept given in the description of the OPINE model, see [b-ITU-T P-Sup.3].

Psychological factors on the psychological scale are additive.

The result of any calculation with the E-model in a first step is a transmission rating factor R , which combines all transmission parameters relevant for the considered connection. This rating factor R is composed of:

$$R = R_o - I_s - I_d - I_{e-eff} + A \quad (7-1)$$

R_o represents in principle the basic signal-to-noise ratio, including noise sources such as circuit noise and room noise. Factor I_s is a combination of all impairments which occur more or less simultaneously with the voice signal. Factor I_d represents the impairments caused by delay and the effective equipment impairment factor I_{e-eff} represents impairments caused by low bit-rate codecs. It also includes impairment due to randomly distributed packet losses. The advantage factor A allows for compensation of impairment factors when the user benefits from other types of access to the user. The term R_o and the I_s and I_d values are subdivided into further specific impairment values. The following clauses give the equations used in the E-model.

(Source: https://www.itu.int/rec/dologin_pub.asp?lang=s&id=T-REC-G.107-201402-S!!PDF-E&type=items)

An estimated mean opinion score (MOS_{CQE}) for the conversational situation in the scale 1-5 can be obtained from the R -factor using the equations:

For $R < 0$: $MOS_{CQE} = 1$

For $0 < R < 100$: $MOS_{CQE} = 1 + 0.035R + R(R - 60)(100 - R)7 \cdot 10^{-6}$ (B-4)

For $R > 100$: $MOS_{CQE} = 4.5$

(Source: https://www.itu.int/rec/dologin_pub.asp?lang=s&id=T-REC-G.107-201402-S!!PDF-E&type=items)

36. The methods practiced by NEC’s use of the accused products include comparing, by the processor, the generated quality index values to quality index values of a first

communication service and determining, by the processor, whether the quality of the second communication service is comparable to a quality of the first communication service based on the comparison. For example, the accused products are used by NEC to implement the ITU-T G.107 Recommendation. The E-model is based on modeling the results from multiple subjective tests performed on a wide range of transmission parameters. It also includes a reference table with different R value and MOS value thresholds, and corresponding perceived voice quality. The MOS values (quality index) in the reference table are obtained using an aggregate of multiple test calls' ("first communication service") data. The computed MOS value is then compared with the reference table. Based on the comparison, it is determined whether the computed MOS value is comparable to the reference MOS value—e.g., whether the second communication service is expected to fall into the same user satisfaction category as the first communication service.

The E-model (**ITU-T Rec. G.107** [1]) is a transmission planning tool that provides a prediction of the expected voice quality, as perceived by a typical telephone user, for a complete end-to-end (i.e. mouth-to-ear) telephone connection under conversational conditions. The E-model takes into account a wide range of telephony-band impairments, in particular the impairment due to low bit-rate coding devices and one-way delay, as well as the "classical" telephony impairments of loss, noise and echo. It can be applied to assess the voice quality of wireline and wireless scenarios, based on circuit-switched and packet-switched technology.

The E-model is based on modeling the results from a large number of subjective tests done in the past on a wide range of transmission parameters. The primary output of the E-model calculations is a scalar quality rating value known as the "Transmission Rating Factor, R". R can be transformed into other quality measures such as Mean Opinion Score (MOS-CQE [2]), Percentage Good or Better ((GoB) or Percentage Poor or Worse ((PoW). However, caution should be exercised when comparing these transformed measures with values of MOS, %GoB or %PoW from other sources, which may not have been obtained under comparable conditions.

(Source: <https://www.itu.int/ITU-T/studygroups/com12/emodelv1/tut.htm>)

R-value (lower limit)	MOS_{CQE} (lower limit)	GoB (%) (lower limit)	PoW (%) (upper limit)	User satisfaction
90	4.34	97	~0	Very satisfied
80	4.03	89	~0	Satisfied
70	3.60	73	6	Some users dissatisfied
60	3.10	50	17	Many users dissatisfied
50	2.58	27	38	Nearly all users dissatisfied

(Source: https://www.itu.int/rec/dologin_pub.asp?lang=s&id=T-REC-G.107-201402-S!!PDF-E&type=items)

An estimated mean opinion score (MOS_{CQE}) for the conversational situation in the scale 1-5 can be obtained from the R -factor using the equations:

For $R < 0$: $MOS_{CQE} = 1$

For $0 < R < 100$: $MOS_{CQE} = 1 + 0.035R + R(R - 60)(100 - R)7 \cdot 10^{-6}$ (B-4)

For $R > 100$: $MOS_{CQE} = 4.5$

(Source: https://www.itu.int/rec/dologin_pub.asp?lang=s&id=T-REC-G.107-201402-S!!PDF-E&type=items)

Range of E-model Rating R	Speech transmission quality category	User satisfaction
$90 \leq R < 100$	Best	Very satisfied
$80 \leq R < 90$	High	Satisfied
$70 \leq R < 80$	Medium	Some users dissatisfied
$60 \leq R < 70$	Low	Many users dissatisfied
$50 \leq R < 60$	Poor	Nearly all users dissatisfied

NOTE 1 - Connections with E-model Ratings R below 50 are not recommended.
 NOTE 2 - Although the trend in transmission planning is to use E-model Ratings R, equations to convert E-model Ratings R into other metrics, e.g. %MOS, %GoB, PoW can be found in **ITU-T Rec. G.107 Annex B** [1].

(Source: <https://www.itu.int/ITU-T/studygroups/com12/emodelv1/tut.htm>)

37. Far North Patents only asserts method claims from the ‘437 Patent.

38. NEC has had knowledge of the ‘437 Patent at least as of the date when it was notified of the filing of this action.

39. Far North Patents has been damaged as a result of the infringing conduct by NEC alleged above. Thus, NEC is liable to Far North Patents in an amount that adequately compensates it for such infringements, which, by law, cannot be less than a reasonable royalty, together with interest and costs as fixed by this Court under 35 U.S.C. § 284.

40. Far North Patents and/or its predecessors-in-interest have satisfied all statutory obligations required to collect pre-filing damages for the full period allowed by law for infringement of the ‘437 Patent.

COUNT III

DIRECT INFRINGEMENT OF U.S. PATENT NO. 7,085,230

41. On August 1, 2006, United States Patent No. 7,085,230 (“the ‘230 Patent”) was duly and legally issued by the United States Patent and Trademark Office for an invention entitled “Method and System for Evaluating the Quality of Packet-Switched Voice Signals.”

42. Far North Patents is the owner of the ‘230 Patent, with all substantive rights in and to that patent, including the sole and exclusive right to prosecute this action and enforce the ‘230 Patent against infringers, and to collect damages for all relevant times.

43. NEC made, had made, used, imported, provided, supplied, distributed, sold, and/or offered for sale products and/or systems including, for example, its NEC Integrated network management system MS5000 family of products that include advanced quality monitoring capabilities (collectively, “accused products”).

Integrated Network Management System(MS5000)



The MS5000 integrated network management system unifies and manages NEC transport nodes (optical, radio, and IP) in your networks. MS5000 enables seamless management of all NEC optical transport products including a submarine cable transmission product to provide a single NEC transport solution.

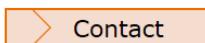

(Source : <https://www.nec.com/en/global/solutions/nsp/oam/index.html>)

NEC's Integrated network management system MS5000 provides end-to-end seamless view of entire network through managing the State management and the configuration management, enabling a full range of fault and performance management functions.

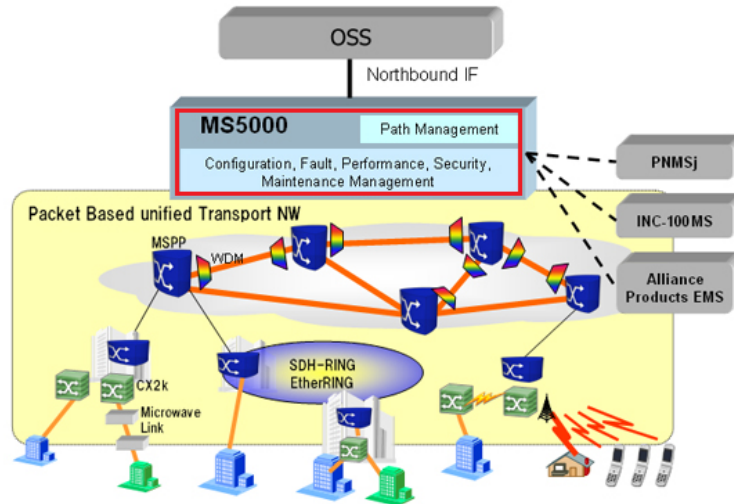

(Source : <https://www.nec.com/en/global/solutions/nsp/nms/index.html>)

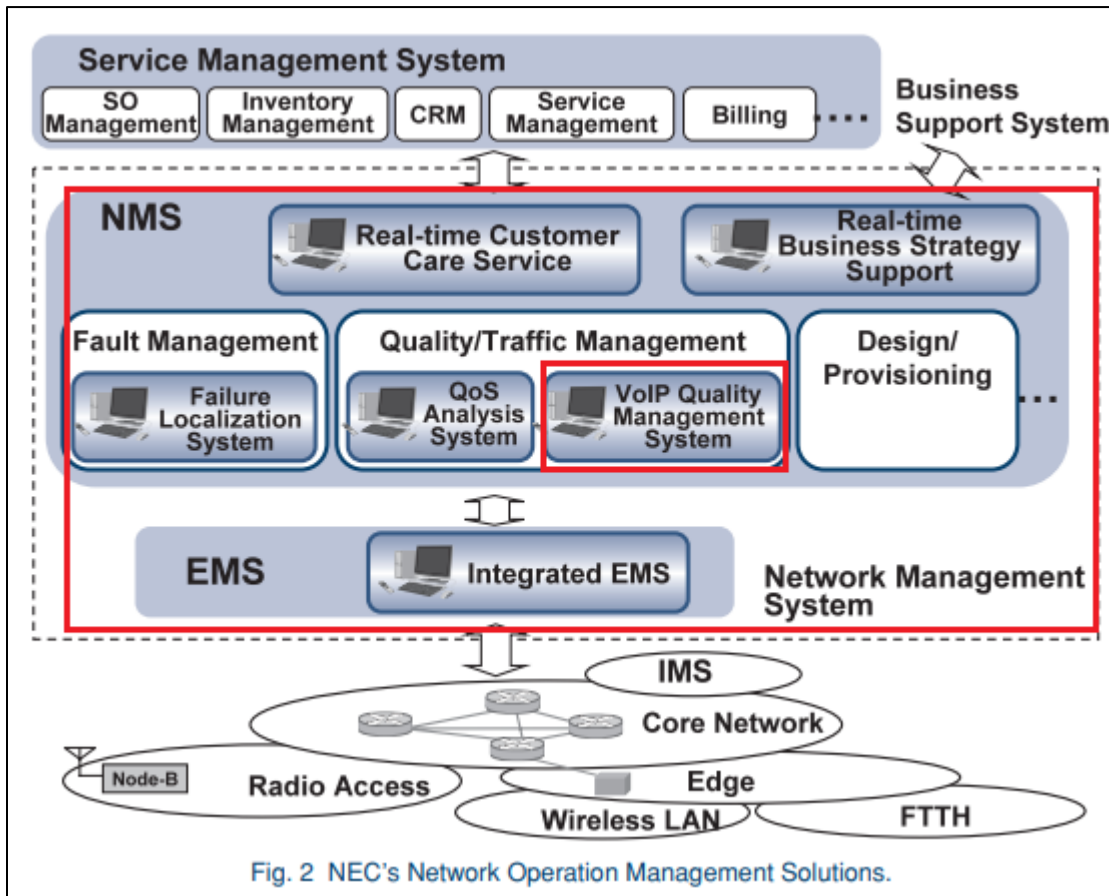

Fig. 2 NEC's Network Operation Management Solutions.

(Source : <https://www.nec.com/en/global/techrep/journal/g06/n02/pdf/t060211.pdf>)

(2) VoIP Quality Measurement System

This system uses an active measurement method which exchanges pseudo RTP calls between probes in order measure the voice quality (R Factor, etc.) of the VoIP services based on the e-model as defined in ITU-T-G.107. These measurements are performed periodically and the collected quality data is stored in the server to enable management of the voice quality status of the network.

(Source : <https://www.nec.com/en/global/techrep/journal/g06/n02/pdf/t060211.pdf>)

44. By doing so, NEC has directly infringed (literally and/or under the doctrine of equivalents) at least Claim 1 of the ‘230 Patent. NEC’s infringement in this regard is ongoing.

45. NEC has infringed the ‘230 Patent by using the accused products and thereby practicing a method for determining acceptability of quality of a second communications service, in comparison to a first communications service which is deemed to exhibit acceptable quality. For example, the accused products are used by NEC to implement the ITU-T G.107 Recommendation. The ITU-T G.107 Recommendation includes an E-model for calculating voice quality as perceived by a typical telephone user. The E-model outputs a transmission rating factor i.e., R, which can be transformed into Mean Opinion Score—i.e., MOS value—that represents the voice quality. This E-model is applied to a real-time voice call (“second communication service”) for measuring its voice quality. The E-model is based on modeling the results from multiple subjective tests performed on a wide range of transmission parameters. It also includes a reference table with different R value and MOS value thresholds, and corresponding perceived voice quality. The MOS values (quality index) in the reference table are obtained using an aggregate of data from multiple test calls using a first communication service.

A MOS value of 4.34 and above, or an R value of 90 and above is considered to be very satisfied (“acceptable quality”).

The E-model: a computational model for use in transmission planning

1 Scope

This Recommendation describes a computational model, known as the E-model, that has proven useful as a transmission planning tool for assessing the combined effects of variations in several transmission parameters that affect the conversational¹ quality of 3.1 kHz handset telephony. This computational model can be used, for example, by transmission planners to help ensure that users will be satisfied with end-to-end transmission performance whilst avoiding over-engineering of networks. It must be emphasized that the primary output from the model is the "rating factor" *R* but this can be transformed to give estimates of customer opinion. Such estimates are only made for transmission planning purposes and not for actual customer opinion prediction (for which there is no agreed-upon model recommended by the ITU-T).

(Source: https://www.itu.int/rec/dologin_pub.asp?lang=s&id=T-REC-G.107-201402-S!!PDF-E&type=items)

An estimated mean opinion score (MOS_{CQE}) for the conversational situation in the scale 1-5 can be obtained from the *R*-factor using the equations:

$$\begin{aligned} \text{For } R < 0: & \quad MOS_{CQE} = 1 \\ \text{For } 0 < R < 100: & \quad MOS_{CQE} = 1 + 0.035R + R(R - 60)(100 - R)7 \cdot 10^{-6} \\ \text{For } R > 100: & \quad MOS_{CQE} = 4.5 \end{aligned} \quad (B-4)$$

(Source: https://www.itu.int/rec/dologin_pub.asp?lang=s&id=T-REC-G.107-201402-S!!PDF-E&type=items)

The E-model (**ITU-T Rec. G.107** [1]) is a transmission planning tool that provides a prediction of the expected voice quality, as perceived by a typical telephone user, for a complete end-to-end (i.e. mouth-to-ear) telephone connection under conversational conditions. The E-model takes into account a wide range of telephony-band impairments, in particular the impairment due to low bit-rate coding devices and one-way delay, as well as the "classical" telephony impairments of loss, noise and echo. It can be applied to assess the voice quality of wireline and wireless scenarios, based on circuit-switched and packet-switched technology.

The E-model is based on modeling the results from a large number of subjective tests done in the past on a wide range of transmission parameters. The primary output of the E-model calculations is a scalar quality rating value known as the "Transmission Rating Factor, *R*". *R* can be transformed into other quality measures such as Mean Opinion Score (MOS_{CQE} [2]), Percentage Good or Better ((GoB) or Percentage Poor or Worse ((PoW)). However, caution should be exercised when comparing these transformed measures with values of MOS, %GoB or %PoW from other sources, which may not have been obtained under comparable conditions.

(Source: <https://www.itu.int/ITU-T/studygroups/com12/emodelv1/tut.htm>)

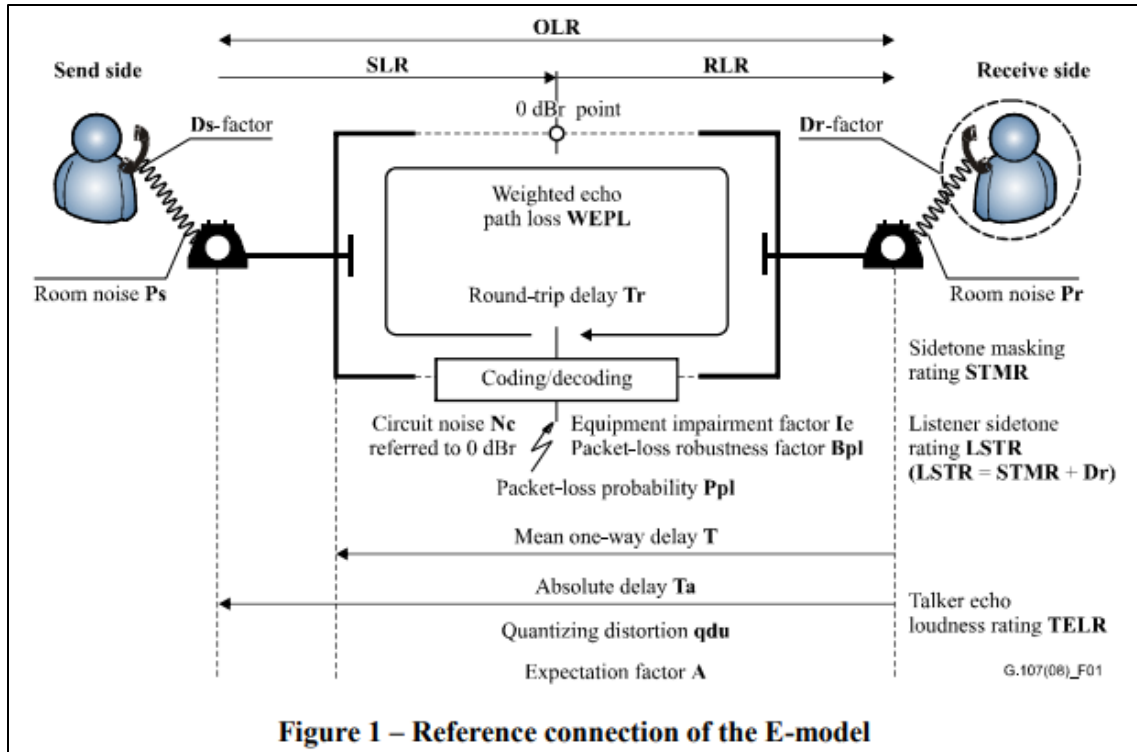

Figure 1 – Reference connection of the E-model

(Source: https://www.itu.int/rec/dologin_pub.asp?lang=s&id=T-REC-G.107-201402-S!!PDF-E&type=items)

7.1 Calculation of the transmission rating factor, R

According to the equipment impairment factor method, the fundamental principle of the E-model is based on a concept given in the description of the OPINE model, see [b-ITU-T P-Sup.3].

Psychological factors on the psychological scale are additive.

The result of any calculation with the E-model in a first step is a transmission rating factor R , which combines all transmission parameters relevant for the considered connection. This rating factor R is composed of:

$$R = R_o - I_s - I_d - I_{e-eff} + A \quad (7-1)$$

R_o represents in principle the basic signal-to-noise ratio, including noise sources such as circuit noise and room noise. Factor I_s is a combination of all impairments which occur more or less simultaneously with the voice signal. Factor I_d represents the impairments caused by delay and the effective equipment impairment factor I_{e-eff} represents impairments caused by low bit-rate codecs. It also includes impairment due to randomly distributed packet losses. The advantage factor A allows for compensation of impairment factors when the user benefits from other types of access to the user. The term R_o and the I_s and I_d values are subdivided into further specific impairment values. The following clauses give the equations used in the E-model.

(Source: https://www.itu.int/rec/dologin_pub.asp?lang=s&id=T-REC-G.107-201402-S!!PDF-E&type=items)

Table B.1 – Provisional guide for the relation between *R*-value and user satisfaction

<i>R</i>-value (lower limit)	MOS_{CQE} (lower limit)	GoB (%) (lower limit)	PoW (%) (upper limit)	User satisfaction
90	4.34	97	~0	Very satisfied
80	4.03	89	~0	Satisfied
70	3.60	73	6	Some users dissatisfied
60	3.10	50	17	Many users dissatisfied
50	2.58	27	38	Nearly all users dissatisfied

(Source: https://www.itu.int/rec/dologin_pub.asp?lang=s&id=T-REC-G.107-201402-S!!PDF-E&type=items)

46. The methods practiced by NEC's use of the accused products include obtaining a first quality index pertaining to the first communications service. For example, the accused products are used by NEC to implement the ITU-T G.107 Recommendation. The E-model includes a reference table with different *R* value and MOS value thresholds, and corresponding perceived voice quality. Further, the E-model is modelled using large number of subjective tests. Thus, the thresholds of MOS value are based on an aggregate of multiple subjective calls' data. For instance, a MOS value ("first quality index") threshold of 4.34 for best quality is based on an aggregate of data for multiple high quality voice calls using a first communication service.

The E-model (**ITU-T Rec. G.107** [1]) is a transmission planning tool that provides a prediction of the expected voice quality, as perceived by a typical telephone user, for a complete end-to-end (i.e. mouth-to-ear) telephone connection under conversational conditions. The E-model takes into account a wide range of telephony-band impairments, in particular the impairment due to low bit-rate coding devices and one-way delay, as well as the "classical" telephony impairments of loss, noise and echo. It can be applied to assess the voice quality of wireline and wireless scenarios, based on circuit-switched and packet-switched technology.

The E-model is based on modeling the results from a large number of subjective tests done in the past on a wide range of transmission parameters. The primary output of the E-model calculations is a scalar quality rating value known as the "Transmission Rating Factor, *R*". *R* can be transformed into other quality measures such as Mean Opinion Score (MOS-CQE [2]), Percentage Good or Better ((GoB) or Percentage Poor or Worse ((PoW). However, caution should be exercised when comparing these transformed measures with values of MOS, %GoB or %PoW from other sources, which may not have been obtained under comparable conditions.

(Source: <https://www.itu.int/ITU-T/studygroups/com12/emodelv1/tut.htm>)

An estimated mean opinion score (MOS_{CQE}) for the conversational situation in the scale 1-5 can be obtained from the R -factor using the equations:

For $R < 0$: $MOS_{CQE} = 1$

For $0 < R < 100$: $MOS_{CQE} = 1 + 0.035R + R(R - 60)(100 - R)7 \cdot 10^{-6}$ (B-4)

For $R > 100$: $MOS_{CQE} = 4.5$

(Source: https://www.itu.int/rec/dologin_pub.asp?lang=s&id=T-REC-G.107-201402-S!!PDF-E&type=items)

Table B.1 – Provisional guide for the relation between R -value and user satisfaction

R-value (lower limit)	MOS_{CQE} (lower limit)	GoB (%) (lower limit)	PoW (%) (upper limit)	User satisfaction
90	4.34	97	~0	Very satisfied
80	4.03	89	~0	Satisfied
70	3.60	73	6	Some users dissatisfied
60	3.10	50	17	Many users dissatisfied
50	2.58	27	38	Nearly all users dissatisfied

(Source: https://www.itu.int/rec/dologin_pub.asp?lang=s&id=T-REC-G.107-201402-S!!PDF-E&type=items)

Table 1 - Definition of categories of speech transmission quality

Range of E-model Rating R	Speech transmission quality category	User satisfaction
$90 \leq R < 100$	Best	Very satisfied
$80 \leq R < 90$	High	Satisfied
$70 \leq R < 80$	Medium	Some users dissatisfied
$60 \leq R < 70$	Low	Many users dissatisfied
$50 \leq R < 60$	Poor	Nearly all users dissatisfied

NOTE 1 – Connections with E-model Ratings R below 50 are not recommended.
 NOTE 2 – Although the trend in transmission planning is to use E-model Ratings R , equations to convert E-model Ratings R into other metrics, e.g. %MOS, %GoB, PoW can be found in **ITU-T Rec. G.107 Annex B [1]**.

(Source: <https://www.itu.int/ITU-T/studygroups/com12/emodelv1/tut.htm>)

47. The methods practiced by NEC’s use of the accused products include obtaining a second quality index pertaining to the second communications service. For example, the accused products are used by NEC to implement the ITU-T G.107 Recommendation. The E-model is

applied to a real-time voice call made using a system including an accused product (“second communication service”) for measuring its voice quality by calculating the R value and its corresponding MOS value (“second quality index”).

7.1 Calculation of the transmission rating factor, R

According to the equipment impairment factor method, the fundamental principle of the E-model is based on a concept given in the description of the OPINE model, see [b-ITU-T P-Sup.3].

Psychological factors on the psychological scale are additive.

The result of any calculation with the E-model in a first step is a transmission rating factor R , which combines all transmission parameters relevant for the considered connection. This rating factor R is composed of:

$$R = R_o - I_s - I_d - I_{e-eff} + A \quad (7-1)$$

R_o represents in principle the basic signal-to-noise ratio, including noise sources such as circuit noise and room noise. Factor I_s is a combination of all impairments which occur more or less simultaneously with the voice signal. Factor I_d represents the impairments caused by delay and the effective equipment impairment factor I_{e-eff} represents impairments caused by low bit-rate codecs. It also includes impairment due to randomly distributed packet losses. The advantage factor A allows for compensation of impairment factors when the user benefits from other types of access to the user. The term R_o and the I_s and I_d values are subdivided into further specific impairment values. The following clauses give the equations used in the E-model.

(Source: https://www.itu.int/rec/dologin_pub.asp?lang=s&id=T-REC-G.107-201402-S!!PDF-E&type=items)

An estimated mean opinion score (MOS_{CQE}) for the conversational situation in the scale 1-5 can be obtained from the R -factor using the equations:

$$\text{For } R < 0: \quad MOS_{CQE} = 1$$

$$\text{For } 0 < R < 100: \quad MOS_{CQE} = 1 + 0.035R + R(R - 60)(100 - R)7 \cdot 10^{-6} \quad (B-4)$$

$$\text{For } R > 100: \quad MOS_{CQE} = 4.5$$

(Source: https://www.itu.int/rec/dologin_pub.asp?lang=s&id=T-REC-G.107-201402-S!!PDF-E&type=items)

48. The methods practiced by NEC’s use of the accused products include determining that the second communication service is of unacceptable quality if the second quality index differs from the first quality index service by more than a selected amount. For example, the

accused products are used by NEC to implement the ITU-T G.107 Recommendation. The calculated MOS value is then compared with the reference table to determine the perceived voice quality. If the R value differs from a R value of 90 by more than 40, then the call is considered to be of unacceptable quality. Similarly, if the calculated MOS value (“second quality index”) differs from a MOS value of 4.34 (“first quality index”) by more than 1.76, then the call is considered to be of unacceptable quality.

Table B.1 – Provisional guide for the relation between *R*-value and user satisfaction

<i>R</i>-value (lower limit)	MOS_{CQE} (lower limit)	GoB (%) (lower limit)	PoW (%) (upper limit)	User satisfaction
90	4.34	97	~0	Very satisfied
80	4.03	89	~0	Satisfied
70	3.60	73	6	Some users dissatisfied
60	3.10	50	17	Many users dissatisfied
50	2.58	27	38	Nearly all users dissatisfied

(Source: https://www.itu.int/rec/dologin_pub.asp?lang=s&id=T-REC-G.107-201402-S!!PDF-E&type=items)

Table 1 - Definition of categories of speech transmission quality

Range of E-model Rating R	Speech transmission quality category	User satisfaction
90 ≤ R < 100	Best	Very satisfied
80 ≤ R < 90	High	Satisfied
70 ≤ R < 80	Medium	Some users dissatisfied
60 ≤ R < 70	Low	Many users dissatisfied
50 ≤ R < 60	Poor	Nearly all users dissatisfied

NOTE 1 – Connections with E-model Ratings R below 50 are not recommended.
 NOTE 2 – Although the trend in transmission planning is to use E-model Ratings R, equations to convert E-model Ratings R into other metrics, e.g. %MOS, %GoB, PoW can be found in **ITU-T Rec. G.107 Annex B [1]**.

(Source: <https://www.itu.int/ITU-T/studygroups/com12/emodelv1/tut.htm>)

49. Far North Patents only asserts method claims from the ‘230 Patent.

50. NEC has had knowledge of the ‘230 Patent at least as of the date when it was notified of the filing of this action.

51. Far North Patents has been damaged as a result of the infringing conduct by NEC alleged above. Thus, NEC is liable to Far North Patents in an amount that adequately compensates it for such infringements, which, by law, cannot be less than a reasonable royalty, together with interest and costs as fixed by this Court under 35 U.S.C. § 284.

52. Far North Patents and/or its predecessors-in-interest have satisfied all statutory obligations required to collect pre-filing damages for the full period allowed by law for infringement of the '230 Patent.

COUNT IV

DIRECT INFRINGEMENT OF U.S. PATENT NO. 8,306,053

53. On November 6, 2012, United States Patent No. 8,306,053 (“the ‘053 Patent”) was duly and legally issued by the United States Patent and Trademark Office for an invention entitled “Methods and Apparatus for Providing Quality-of-Service Guarantees in Computer Networks.”

54. Far North Patents is the owner of the ‘053 Patent, with all substantive rights in and to that patent, including the sole and exclusive right to prosecute this action and enforce the ‘053 Patent against infringers, and to collect damages for all relevant times.

55. NEC made, had made, used, imported, provided, supplied, distributed, sold, and/or offered for sale products and/or systems including, for example, its NEC QX-S1000, QX-S4100, and QX-S5200 Series PoE+ Gigabit Ethernet Switch families of products that include advanced quality of service capabilities (collectively, “accused products”).



(Source : <https://www.nec-enterprise.com/documents?id=1231&hash=ee65e0bee7d7c9fdc17193aecbcca809e2a295fa56a3f88ae7b654c497b1afa1>)

Specifications

Features		S1008GT-2G-PW	S1016GT-4G-PW	S1024GT-4G-PW
Performance	Switching capacity [bps]	20.0G	40.0G	56.0G
	Transfer rate [pps]	14.8M	29.7M	41.6M
	Switching method			S&F
	MAC address table			8K
	Routing table (IPv4/IPv6)			-
Interface	ARP table			32
	1Gbe	8	16	24
	10/100-1000BASE-T			
	SFP slot	2	4	4
PoE+	Console Port	√	√	√
	Number of power feedable interfaces	8	16	24
	Power feeding standard			IEEE802.3af/at
	Maximum power supply amount per port			30.0W
IRF	Maximum power supply amount per device	65.0W	124.0W	180.0W
	IRF stack version			-
	Maximum number of IRF stacks			-
VLAN	MAD/ISSU			-
	IEEE802.1Q			√
	Port VLAN			√
	Protocol VLAN			-
	Voice VLAN			√
	Max. number of VLAN			4094
	VLAN mapping			-
QinQ			-	

(Source : <https://www.nec-enterprise.com/documents?id=1231&hash=ee65e0bee7d7c9fdc17193aecbcca809e2a295fa56a3f88ae7b654c497b1afa1>)

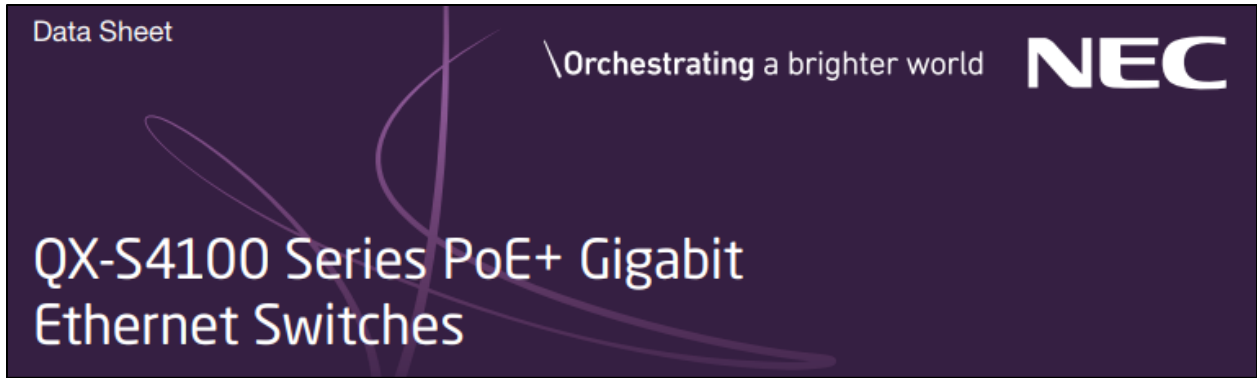

(Source : <https://www.necam.com/docs/?id=d424b393-56d0-44b0-92e1-59e10359ed91>)

Specifications		S4108GT-2G-PW	S4116GT-4G-PW	S4124GT-4G-PW	S4148GT-4G-PW	
Performance	Switching capacity [bps]	20.0G	40.0G	56.0G	104.0G	
	Transfer rate [pps]	14.8M	29.7M	41.6M	77.3M	
	Switching method	S&F				
	MAC address table	16K				
	Routing table (IPv4/IPv6)	64/64				
	ARP table	256				
Interface	1Gbe	10/100-1000BASE-T	8	16	28	48
		SFP slot	2	4	4c	4
	Console Port		√	√	√	√
PoE+	Number of power feedable interfaces	8	16	24	48	
	Power feeding standard	IEEE802.3at				
	Maximum power supply amount per port	30.0W				
	Maximum power supply amount per device	125.0W	170.0W		370.0W	
IRF	IRF stack version	IRFv2				
	Maximum number of IRF stacks	4				
	MAD/ISSU	√ / -				
VLAN	IEEE802.1Q	√				
	Port VLAN	√				
	Protocol VLAN	√				
	Voice VLAN	√				
	Maximum number of VLAN [number of settable IP addresses]	4094[32]				
	VLAN mapping	√				

(Source : <https://www.necam.com/docs/?id=d424b393-56d0-44b0-92e1-59e10359ed91>)

S-0301
October 24, 2019

QX-S1000 Ethernet Switch Family

NEC Corporation of America (NEC) offers a diverse range of **commercial-grade** switches:

- QX-S1000 and QX-S4100 product lines for SMB applications
- QX-S5200 product line of access switches for larger, Enterprise applications
- QX-S6600 product line for aggregation in Enterprise networking.

These product lines include non-PoE switches for data applications as well as PoE+ switches that can supply power to SL2100 IP phones, access points and other IoT devices). QX switches can be managed by the SDN Controller, WebGUI management console, or Command Line Interface (CLI).

We are happy to announce that the entire QX family of switches is now available through our Distributor network.

(Source : <http://ntsdirect.com/wp-content/uploads/2019/12/QX-S1000-Ethernet-Switch-Family-1.pdf>)

Data Sheet

\Orchestrating a brighter world **NEC**

QX-S5200 Series PoE+ Gigabit Ethernet Switches

(Source : https://s3.eu-central-1.amazonaws.com/z3r2zxopa4uuqpw5a4ju/sdnospace/files/pdf/datasheet-NEC-Qx%20S5200%20PoE%2010G%20Switch_eng%202018-v01.pdf)

Specifications			S5224GT-4X-PW	S5248GT-4X-PW
Performance	Switching capacity [bps]		128.0G	176.0G
	Transfer rate [pps]		95.2M	130.9M
	Switching method			S&F
	MAC address table			16K
	Routing table (IPv4/IPv6)			512/256
Interface	ARP table			1K
	10Gbe	SFP slot	-	-
		SFP+ slot	4	4
	40Gbe	QSFP+ slot	-	-
		Console Port	√	√
PoE+	Number of power feedable interfaces		24	48
	Power feeding standard			IEEE802.3at
	Maximum power supply amount per port			30.0W
	Maximum power supply amount per device			370.0W
IRF	IRF stack version			IRFv2
	Maximum number of IRF stacks			6
	MAD/ISSU			√/ -
VLAN	IEEE802.1Q			√
	Port VLAN			√
	Protocol VLAN			√
	Voice VLAN			√
	Max. number of VLAN [number of settable IP addresses]			4094[32]
	VLAN mapping			√
	QinQ			√
	Auto Negotiation/fixed speed and duplex (full/half)			√/√
	Auto MDI • MDIX/ fixed MDIX			√/√
	Flow control (IEEE802.3X)			√
EAP transmitted/BPDU transmitted			√/√	
Port isolate			√	
Packet transfer suppression			B/M/U	

(Source : https://s3.eu-central-1.amazonaws.com/z3r2zxopa4uuqpw5a4ju/sdn-space/files/pdf/datasheet-NEC-Qx%20S5200%20PoE%2010G%20Switch_eng%202018-v01.pdf)

56. By doing so, NEC has directly infringed (literally and/or under the doctrine of equivalents) at least Claims 1 and 14 of the ‘053 Patent. NEC’s infringement in this regard is ongoing.

57. NEC has infringed the ‘053 Patent by making, having made, using, importing, providing, supplying, distributing, selling or offering for sale products including a device adapter comprising a transmission unit configured to transmit data from a real time device via a network

according to a time frame, wherein the time frame is substantially synchronized in the device adapter and at least one other device adapter, the time frame repeating periodically and including a plurality of assigned time phases and a free access phase. For example, the accused products are configured to be used to implement the IEEE 802.1Q standard. IEEE standard 802.1Q implements a method in which a time aware bridged LAN transmits data from one end point i.e, Precision Time Protocol (“PTP”) instance to another. The endpoints transmit data that is a mix of time-critical traffic and other traffic, (i.e, real time data and non-real time data) via PTP instances such as bridges (device adapters). The end point can be either a real time device or a non-real time device. The bridged network uses 802.1AS base time to synchronize all the clocks of ports associated with bridges (device adapters). Using the Best Master Clock Algorithm, the synchronization time signal is transmitted from a grandmaster to other ports. IEEE Std. 802.1AS™-2011 is normative and essential to implement an IEEE Std. 802.1Q Compliant System. IEEE Std. 802.1Q-2018 defines parameters, such as AdminBaseTime and OpenBaseTime, which are used to synchronize the clocks across the network. The bridges containing ports schedule the transmission of traffic based on the synchronized time. Each port associated with a specific set of transmission queues includes a plurality of transmission gates. A transmission gate can be in a closed state or open state. The functionality of assigned time phases is achieved using open gates transmitting data packets during transmission time. The functionality of a free access phase is achieved when the gates are opened for transmission during any time. IEEE Std. 802.1Q-2018 supports cyclic queuing and forwarding structures to create synchronized frames and gates which repeat periodically (Annex T).

1.1 Project Number: P802.1Qbv
1.2 Type of Document: Standard
1.3 Life Cycle: Full Use

2.1 Title: Standard for Local and metropolitan area networks--Media Access Control (MAC) Bridges and Virtual Bridged Local Area Networks Amendment: Enhancements for Scheduled Traffic

5.2.b. Scope of the project: This amendment specifies time-aware queue-drawing procedures, managed objects and extensions to existing protocols that enable bridges and end stations to schedule the transmission of frames based on a synchronized time. Virtual Local Area Network (VLAN) tag encoded priority values are allocated allowing simultaneous support of scheduled traffic, credit-based shaper traffic and other bridged traffic over Local Area Networks (LANs).

(Source: <http://www.ieee802.org/1/files/public/docs2014/bv-p802-1Qbv-par-modification-1114.pdf>)

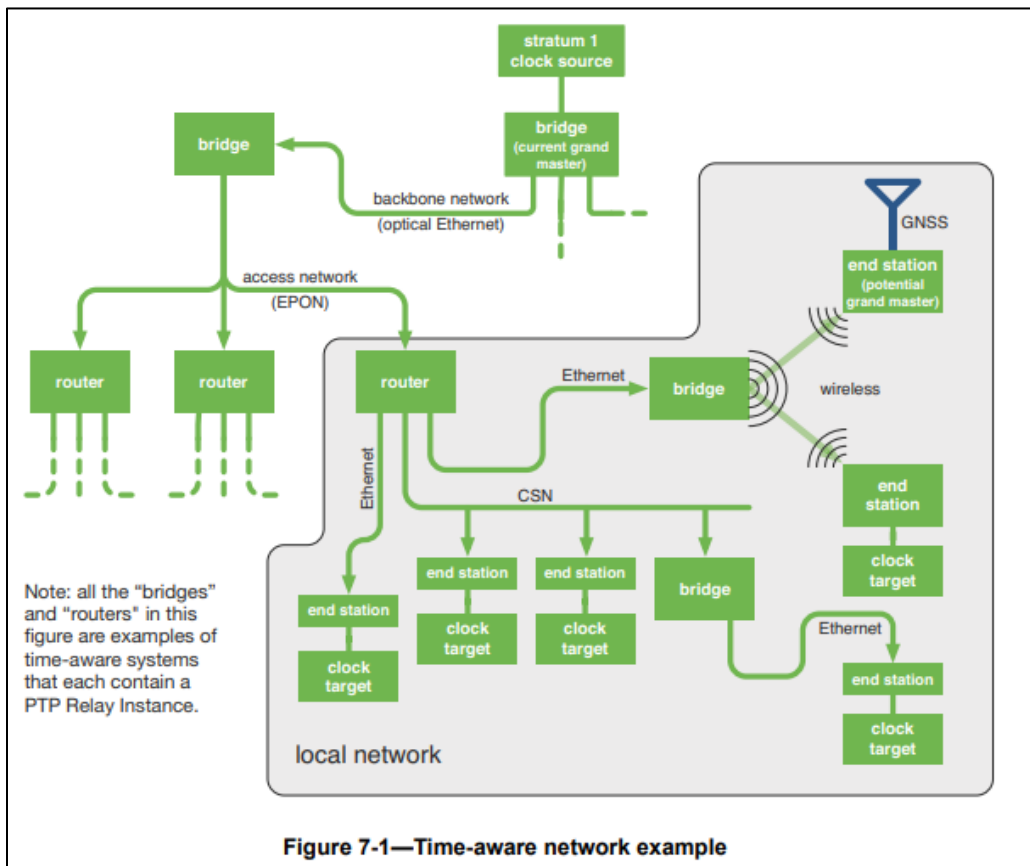

(Source: <https://1.ieee802.org/wp-content/uploads/2019/03/802-1AS-rev-d8-0.pdf>)

7.2 Architecture of a time-aware network

7.2.1 General

A time-aware network consists of a number of interconnected time-aware systems that support the gPTP defined within this standard. These time-aware systems can be any networking device, including, for example, bridges, routers, and end stations. A set of time-aware systems that are interconnected by gPTP-capable network elements is called a gPTP network. Each instance of gPTP that the time-aware systems support is in one *gPTP domain*, and the instances of gPTP are said to be part of that gPTP domain. A time-aware system can support, and therefore be part of, more than one gPTP domain. The entity of a single time-aware system that executes gPTP in one gPTP domain is called a PTP Instance. A time-aware system can contain multiple PTP Instances, which are each associated with a different gPTP domain. There are two

(Source: <https://1.ieee802.org/wp-content/uploads/2019/03/802-1AS-rev-d8-0.pdf>)

3.16 PTP End Instance: A PTP Instance that is capable of acting as the source of synchronized time on the network, or destination of synchronized time using the IEEE 802.1AS protocol, or both.

3.17 PTP Instance: A PTP Relay Instance or a PTP End Instance. A PTP Instance implements those portions of this standard indicated as applicable to a PTP Relay Instance or a PTP End Instance. Each PTP Instance operates in exactly one domain.

3.18 PTP Link: Within a domain, a network segment between two PTP Ports using the peer-to-peer delay mechanism of this standard. The peer-to-peer delay mechanism is designed to measure the propagation time over such a link.

NOTE—A PTP Link between PTP Ports of PTP Instances is also a gPTP Communication Path (see 3.9).

3.19 PTP Relay Instance: A PTP Instance that is capable of communicating synchronized time received on one port to other ports, using the IEEE 802.1AS protocol.

NOTE—A PTP Relay Instance could, for example, be contained in a bridge, a router, or a multi-port end station.

(Source: <https://1.ieee802.org/wp-content/uploads/2019/03/802-1AS-rev-d8-0.pdf>)

Traffic scheduling

This annex provides some background to the mechanisms provided in this standard for traffic scheduling, with the intent of providing some insight into the motivation for the provision of mechanisms for traffic scheduling and some of the ways that the mechanisms might be used.

Q.1 Motivation

Some applications have a need for frame delivery that is highly predictable in terms of the time at which frame transmission will occur, and the overall latency and jitter that will be experienced as the frame is propagated to its destination. Examples include industrial and automotive control applications, where data transmitted over the network is used to feed the parameters of control loops that are critical to the operation of the plant or machinery involved, and where frames carrying control data are transmitted on a repeating time schedule: late delivery of such frames can result in instability, inaccuracy, or failure of the operation of the control loops concerned. In some implementations, this need has been met by the provision of dedicated, highly engineered networks that are used solely for the transmission of time-critical control traffic; however, as the bandwidth occupied by such traffic is often low, and the cost of providing a dedicated control network can be high, it can be desirable to mix time-critical traffic with other classes of traffic in the same network, as long as such mixing can be achieved while still meeting the timing requirements of the time-critical traffic.

(Source: IEEE Standard for Local and metropolitan area networks— Bridges and Bridged Networks Amendment 25: Enhancements for Scheduled Traffic (IEEE 802.1Qbv-2015))

- b) gPTP specifies a media-independent sublayer that simplifies the integration within a single timing domain of multiple different networking technologies with radically different media access protocols. gPTP specifies a media-dependent sublayer for each medium. The information exchanged between PTP Instances has been generalized to support different packet formats and management schemes appropriate to the particular networking technology. IEEE Std 1588-2019, on the other

(Source: <https://1.ieee802.org/wp-content/uploads/2019/03/802-1AS-rev-d8-0.pdf>)

7.2.2 Time-aware network consisting of a single gPTP domain

Figure 7-1 illustrates an example time-aware network consisting of a single gPTP domain, using all the above network technologies (i.e., (c) - (f) of 7.2.1), where end stations on several local networks are connected to a grandmaster on a backbone network via an EPON access network.

Any PTP Instance with clock sourcing capabilities can be a potential grandmaster, so there is a selection method (the best master clock algorithm, or BMCA) that ensures that all of the PTP Instances in a gPTP domain use the same grandmaster.¹² The BMCA is largely identical to that used in IEEE Std 1588-2019,

(Source: <https://1.ieee802.org/wp-content/uploads/2019/03/802-1AS-rev-d8-0.pdf>)

10.3.1.1 Best master clock algorithm overview

In the BMCA (i.e., method (a) of 10.3.1), best master selection information is exchanged between PTP Instances of time-aware systems via Announce messages (see 10.5 and 10.6). Each Announce message contains time-synchronization spanning tree vector information that identifies one PTP Instance as the root of the time-synchronization spanning tree and, if the PTP Instance is grandmaster-capable, the grandmaster. Each PTP Instance in turn uses the information contained in the Announce messages it receives, along with its knowledge of itself, to compute which of the PTP Instances that it has knowledge of ought to be the root of the spanning tree and, if grandmaster-capable, the grandmaster. As part of constructing the time-synchronization spanning tree, each port of each PTP Instance is assigned a port state from Table 10-2 by state machines associated with the ports and with the PTP Instance as a whole.

(Source: <https://1.ieee802.org/wp-content/uploads/2019/03/802-1AS-rev-d8-0.pdf>)

c) In gPTP there are only two types of PTP Instances: PTP End Instances and PTP Relay Instances, while IEEE 1588 has ordinary clocks, boundary clocks, end-to-end transparent clocks, and P2P transparent clocks. A PTP End Instance corresponds to an IEEE 1588 ordinary clock, and a PTP Relay Instance is a type of IEEE 1588 boundary clock where its operation is very tightly defined, so much so that a PTP Relay Instance with Ethernet ports can be shown to be mathematically equivalent to a P2P transparent clock in terms of how synchronization is performed, as shown in

(Source: <https://1.ieee802.org/wp-content/uploads/2019/03/802-1AS-rev-d8-0.pdf>)

• Grand Master selection

- GM-capable stations advertise themselves via ANNOUNCE messages
- If a station hears from station with “better” clock, it does not send ANNOUNCE
 - Configurable “Priority” field can override clock quality
 - MAC address is tie breaker
- Time relays drop all inferior ANNOUNCE messages
 - Forward only the best
- Last one standing is Grand Master for the domain
 - GM is the root of the 802.1AS timing tree
 - GM periodically sends the current time

(Source: <https://avnu.org/wp-content/uploads/2014/05/as-kbstanton-8021AS-tutorial-0714-v01.pdf>)

IEEE Std 802.1Q-2018
IEEE Standard for Local and Metropolitan Area Networks—Bridges and Bridged Networks

2. Normative references

The following referenced documents are indispensable for the application of this document (i.e., they must be understood and used, so each referenced document is cited in the text and its relationship to this document is explained). For dated references, only the edition cited applies. For undated references, the latest edition of the referenced document (including any amendments or corrigenda) applies.

ANSI X3.159, American National Standards for Information Systems—Programming Language—C.⁵

IEEE Std 802[®], IEEE Standard for Local and metropolitan area networks: Overview and Architecture.^{6,7}

IEEE Std 802.1AB[™], IEEE Standard for Local and metropolitan area networks—Station and Media Access Control Connectivity Discovery.

IEEE Std 802.1AC[™], IEEE Standard for Local and metropolitan area networks—Media Access Control (MAC) Service Definition.

IEEE Std 802.1AE[™], IEEE Standard for Local and metropolitan area networks—Media Access Control (MAC) Security.

IEEE Std 802.1AS[™], IEEE Standard for Local and metropolitan area networks—Timing and Synchronization for Time-Sensitive Applications in Bridged Local Area Networks.

(Source: IEEE Standard for Local and Metropolitan Area Networks—Bridges and Bridged Networks- IEEE Std 802.1Q[™]-2018)

8.6.9.4.1 AdminBaseTime

The administrative value of base time, expressed as an IEEE 1588 precision time protocol (PTP) [B24] timescale (see 8.2 of IEEE Std 802.1AS[™]-2011 [B11]). This value can be changed by management, and is used by the List Config state machine (8.6.9.3) to set the value of OperBaseTime (8.6.9.4.18).

NOTE—Time is expressed in the PTP timescale as the number of seconds, nanoseconds, and fractional nanoseconds that have elapsed since 1 January 1970 00:00:00 TAI.

NOTE 2—If AdminBaseTime is set to the same time in the past in all bridges and end stations, OperBaseTime is always in the past, and all cycles start synchronized. Using AdminBaseTime in the past is appropriate when you can start schedules prior to starting the application that uses the schedules. Use of AdminBaseTime in the future is intended to change a currently running schedule in all bridges and end stations to a new schedule at a future time. Using AdminBaseTime in the future is appropriate when schedules must be changed without stopping the application.

(Source: IEEE Standard for Local and Metropolitan Area Networks—Bridges and Bridged Networks- IEEE Std 802.1Q[™]-2018)

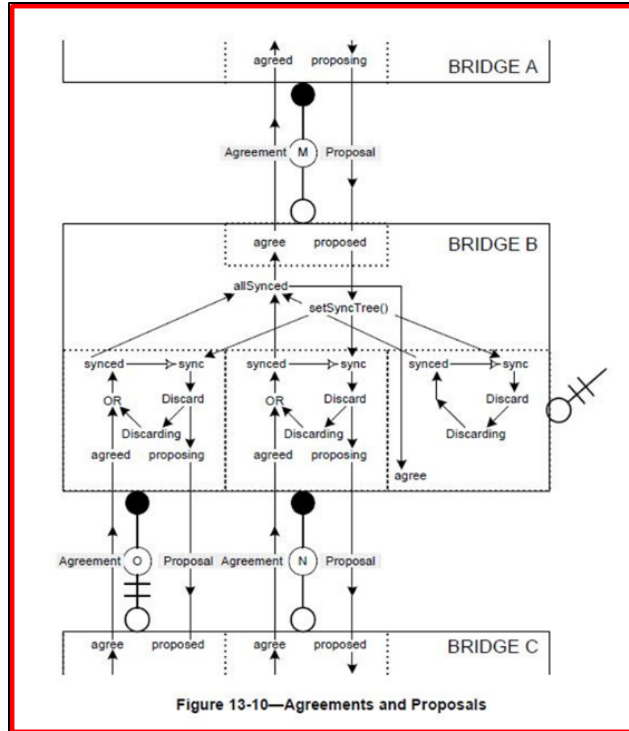

(Source: IEEE Standard for Local and Metropolitan Area Networks—Bridges and Bridged Networks- IEEE Std 802.1Q™-2018)

NOTE 2—Agreements can be generated without prior receipt of a Proposal as soon as the necessary conditions are met. Subsequent receipt of a Proposal serves to elicit a further Agreement. If all other ports have already been synchronized (allSynced in Figure 13-10) and the Proposal’s priority vector does not convey worse information, synchronization is maintained and there is no need to transition Designated Ports to Discarding once more, or to transmit further Proposals.

(Source: IEEE Standard for Local and Metropolitan Area Networks—Bridges and Bridged Networks- IEEE Std 802.1Q™-2018)

8.6.8.4 Enhancements for scheduled traffic

A Bridge or an end station may support enhancements that allow transmission from each queue to be scheduled relative to a known timescale. In order to achieve this, a transmission gate is associated with each queue; the state of the transmission gate determines whether or not queued frames can be selected for transmission (see Figure 8-12). For a given queue, the transmission gate can be in one of two states:

- a) Open: Queued frames are selected for transmission, in accordance with the definition of the transmission selection algorithm associated with the queue.
- b) Closed: Queued frames are not selected for transmission.

(Source: IEEE Standard for Local and metropolitan area networks— Bridges and Bridged Networks Amendment 25: Enhancements for Scheduled Traffic (IEEE 802.1Qbv-2015))

8.6.8 Transmission selection

For each Port, frames are selected for transmission on the basis of the traffic classes that the Port supports and the operation of the transmission selection algorithms supported by the corresponding queues on that Port. For a given Port and traffic class, frames are selected from the corresponding queue for transmission if and only if

- a) The operation of the transmission selection algorithm supported by that queue determines that there is a frame available for transmission; and
- b) For each queue corresponding to a numerically higher value of traffic class supported by the Port, the operation of the transmission selection algorithm supported by that queue determines that there is no frame available for transmission.

(Source: IEEE Standard for Local and Metropolitan Area Networks—Bridges and Bridged Networks- IEEE Std 802.1Q™-2018)

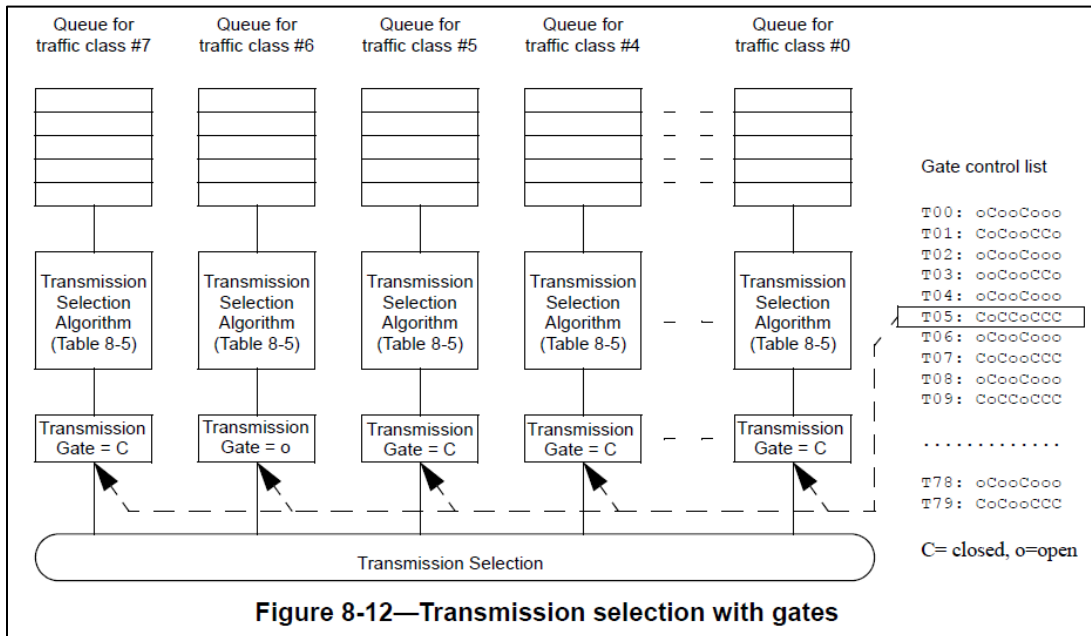

Figure 8-12—Transmission selection with gates

(Source: IEEE Standard for Local and metropolitan area networks— Bridges and Bridged Networks Amendment 25: Enhancements for Scheduled Traffic (IEEE 802.1Qbv-2015))

A gate control list associated with each Port contains an ordered list of gate operations. Each gate operation changes the transmission gate state for the gate associated with each of the Port's traffic class queues. In an implementation that does not support enhancements for scheduled traffic, all gates are assumed to be permanently in the open state. Table 8-6 identifies the gate operation types, their parameters, and the actions that result from their execution. The state machines that control the execution of the gate control list, along with their variables and procedures, are specified in 8.6.9.

(Source: IEEE Standard for Local and metropolitan area networks— Bridges and Bridged Networks Amendment 25: Enhancements for Scheduled Traffic (IEEE 802.1Qbv-2015)).

3.3 gating cycle: The period of time over which the sequence of operations in a gate control list repeats.

3.4 transmission gate: A gate that connects or disconnects the transmission selection function of the forwarding process from the queue, allowing or preventing it from selecting frames from that queue. The gate has two states, Open and Closed.

(Source: IEEE Standard for Local and metropolitan area networks— Bridges and Bridged Networks Amendment 25: Enhancements for Scheduled Traffic (IEEE 802.1Qbv-2015))

Cyclic queuing and forwarding⁵³

T.1 Overview of CQF

Cyclic queuing and forwarding (CQF) is a method of traffic shaping that can deliver deterministic, and easily calculated, latency for time-sensitive traffic streams. As the name implies, the principle underlying CQF is that stream traffic is transmitted and queued for transmission along a network path in a cyclic manner. Time is divided into numbered time intervals $i, i+1, i+2, \dots, i+N$, each of duration d . Frames transmitted by a Bridge, *Alice*, during time interval i are received by a downstream Bridge, *Bob*, during time interval i and are transmitted onwards by *Bob* towards Bridge *Charlie* during time interval $i+1$, and so on. A starting assumption is that, for a given traffic class, all Bridges and all end stations connected to a given bridge have a common understanding (to a known accuracy) of the start time of cycle i , and the cycle duration, d .

Frames transmitted by *Alice* during interval i are transmitted by *Bob* in interval $i+1$; the maximum possible delay experienced by a given frame is from the beginning of i to the end of $i+1$, or twice d . Similarly, the minimum possible delay experienced is from the end of i to the beginning of $i+1$, which is zero. More generally, the maximum delay experienced by a given frame is

$$(h+1) \times d$$

and the minimum delay experienced by a given frame is

$$(h-1) \times d$$

where h is the number of hops.

(Source: IEEE Standard for Local and Metropolitan Area Networks—Bridges and Bridged Networks- IEEE Std 802.1Q™-2018)

58. The accused products include a device adapter that is configured to transmit data during at least one of an assigned time phase associated with the device adapter prior to transmission of data from the real-time device by the device adapter, and included in the plurality of assigned time phases, or the free access phase, to refrain from transmitting data during time phases of the plurality of assigned time phases that are not associated with the device adapter, and to be able to determine whether to defer transmission of data during the assigned time phase associated with the device adapter and the free access phase to allow a non-real time device to transmit data. For example, the accused products are configured to be used to implement the IEEE 802.1Q standard. IEEE standard 802.1Q shows that scheduling of ports' transmission gates (configured) for transmission of data starts prior to the transmission of real-time data. The functionality of assigned time phases is achieved using open gates transmitting data packets during scheduled transmission time. Per Clause 8.6.8 of the IEEE Std. 802.1Q, each time phase is assigned to a specific device adapter prior to transmission of real-time data by the specific device adapter. Furthermore, IEEE 802.1Q performs traffic shaping through Per-Stream Filtering and Policing (PSTP). IEEE standard 802.1Q implements a method in which open gates transmit data packets during transmission time and closed gates refrain data packets from transmission. The functionality of assigned time phases is achieved using open gates transmitting data packets during transmission time. The functionality of free access phase is achieved by the gates that are opened for transmission during any time. IEEE Std. 802.1Q supports Forwarding and Queuing Enhancements for Time Sensitive Streams. Thus, one of the plurality of device adaptors is configured to transmit data during at least one of a respective assigned time phase or

free access phase, to refrain from transmitting data during time phases not assigned to the respective one of the plurality of device adapters. IEEE Std. 802.1Q provides traffic shaping for various classes of data transmission and determining whether to defer transmission of data during at least one of the assigned time phase or the free access phase to allow a non-real time device to transmit data.

NOTE 2—If AdminBaseTime is set to the same time in the past in all bridges and end stations, OperBaseTime is always in the past, and all cycles start synchronized. Using AdminBaseTime in the past is appropriate when you can start schedules prior to starting the application that uses the schedules. Use of AdminBaseTime in the future is intended to

(Source: IEEE Standard for Local and metropolitan area networks— Bridges and Bridged Networks Amendment 25: Enhancements for Scheduled Traffic (IEEE 802.1Qbv-2015))

1.1 Project Number: P802.1Qbv
1.2 Type of Document: Standard
1.3 Life Cycle: Full Use

5.5 Need for the Project: The credit-based shaper works well in arbitrary networks (i.e., non-engineered). Networks employing scheduled transmissions are able to control real-time processes. This amendment enables those two kinds of networks to be consolidated into a single network, with a significant cost reduction to the user.

(Source: <http://www.ieee802.org/1/files/public/docs2014/bv-p802-1Qbv-par-modification-1114.pdf>)

8.6.8 Transmission selection

For each Port, frames are selected for transmission on the basis of the traffic classes that the Port supports and the operation of the transmission selection algorithms supported by the corresponding queues on that Port. For a given Port and traffic class, frames are selected from the corresponding queue for transmission if and only if

- a) The operation of the transmission selection algorithm supported by that queue determines that there is a frame available for transmission; and
- b) For each queue corresponding to a numerically higher value of traffic class supported by the Port, the operation of the transmission selection algorithm supported by that queue determines that there is no frame available for transmission.

(Source: IEEE Standard for Local and Metropolitan Area Networks—Bridges and Bridged Networks- IEEE Std 802.1Q™-2018)

5.4.1.9 Cyclic queuing and forwarding (CQF) requirements

A VLAN Bridge component implementation that conforms to the provisions of this standard for CQF (see Annex T) shall

- a) Support the enhancements for scheduled traffic as specified in 8.6.8.4.
- b) Support the state machines for scheduled traffic as specified in 8.6.9.
- c) Support the state machines for stream gate control as specified in 8.6.10.
- d) Support the management entities for scheduled traffic as specified in 12.29.
- e) Support the requirements for per-stream filtering and policing (PSFP) as stated in 5.4.1.8.
- f) Support the management entities for PSFP as specified in 12.31.

(Source: IEEE Standard for Local and Metropolitan Area Networks—Bridges and Bridged Networks- IEEE Std 802.1Q™-2018)

5.4.1.5 Forwarding and Queuing Enhancements for time-sensitive streams (FQTSS)—requirements

A VLAN Bridge component implementation that conforms to the provisions of this standard for FQTSS shall

- a) Support a minimum of two traffic classes on all Ports, of which
 - 1) A minimum of one traffic class supports the strict priority algorithm for transmission selection (8.6.8.1), and
 - 2) One traffic class is a stream reservation (SR) class.
- b) Support the operation of the credit-based shaper algorithm (8.6.8.2) on all Ports as the transmission selection algorithm used for the SR class.
- c) Support SRP domain boundary port priority regeneration override as defined in 6.9.4, and the default priority regeneration override value defined in Table 6-5, for SR class “B.”
- d) Support the tables and procedures for mapping priorities to traffic classes as defined in 34.5.

SR: Stream Reservation, SRP: Stream Reservation Protocol

(Source: IEEE Standard for Local and Metropolitan Area Networks—Bridges and Bridged Networks- IEEE Std 802.1Q™-2018)

8.6.8.4 Enhancements for scheduled traffic

A Bridge or an end station may support enhancements that allow transmission from each queue to be scheduled relative to a known timescale. In order to achieve this, a transmission gate is associated with each queue; the state of the transmission gate determines whether or not queued frames can be selected for transmission (see Figure 8-12). For a given queue, the transmission gate can be in one of two states:

- a) Open: Queued frames are selected for transmission, in accordance with the definition of the transmission selection algorithm associated with the queue.
- b) Closed: Queued frames are not selected for transmission.

(Source: IEEE Standard for Local and metropolitan area networks— Bridges and Bridged Networks Amendment 25: Enhancements for Scheduled Traffic (IEEE 802.1Qbv-2015))

A gate control list associated with each Port contains an ordered list of gate operations. Each gate operation changes the transmission gate state for the gate associated with each of the Port's traffic class queues. In an implementation that does not support enhancements for scheduled traffic, all gates are assumed to be permanently in the open state. Table 8-6 identifies the gate operation types, their parameters, and the actions that result from their execution. The state machines that control the execution of the gate control list, along with their variables and procedures, are specified in 8.6.9.

(Source: IEEE Standard for Local and metropolitan area networks— Bridges and Bridged Networks Amendment 25: Enhancements for Scheduled Traffic (IEEE 802.1Qbv-2015))

5.4.1.5 Forwarding and Queuing Enhancements for time-sensitive streams (FQTSS)— requirements

A VLAN Bridge component implementation that conforms to the provisions of this standard for FQTSS shall

- a) Support a minimum of two traffic classes on all Ports, of which
 - 1) A minimum of one traffic class supports the strict priority algorithm for transmission selection (8.6.8.1), and
 - 2) One traffic class is a stream reservation (SR) class.
- b) Support the operation of the credit-based shaper algorithm (8.6.8.2) on all Ports as the transmission selection algorithm used for the SR class.
- c) Support SRP domain boundary port priority regeneration override as defined in 6.9.4, and the default priority regeneration override value defined in Table 6-5, for SR class "B."
- d) Support the tables and procedures for mapping priorities to traffic classes as defined in 34.5.

SR: Stream Reservation, SRP: Stream Reservation Protocol

(Source: IEEE Standard for Local and Metropolitan Area Networks—Bridges and Bridged Networks- IEEE Std 802.1Q™-2018)

5.4.1.6 ETS Bridge requirements

A device supporting ETS shall

- a) Support at least 3 traffic classes (37.3).

NOTE—A minimum of 3 traffic classes allows a minimum configuration such that one traffic class contains priorities with PFC enabled, one traffic class contains priorities with PFC disabled, and one traffic class using strict priority.

- b) Support bandwidth configuration with a granularity of 1% or finer (37.3).
- c) Support bandwidth allocation with a precision of 10% (37.3).
- d) Support a transmission selection policy such that if one of the traffic classes does not consume its allocated bandwidth, then any unused bandwidth is available to other traffic classes (37.3).
- e) Support DCBX (Clause 38).

(Source: IEEE Standard for Local and Metropolitan Area Networks—Bridges and Bridged Networks- IEEE Std 802.1Q™-2018)

59. NEC has infringed the '053 Patent by using the accused products and thereby practicing a method that includes transmitting a synchronization signal at regular intervals to synchronize local clocks of each of a plurality of device adapters. For example, the accused products are used by NEC to implement the IEEE 802.1Q standard. IEEE standard 802.1Q implements a method in which a time aware bridged LAN use 802.1AS base time to synchronize all the clocks of ports associated with bridges (device adapters) by periodically (regular intervals) sending the Announce messages. Using Best Master Clock Algorithm, the synchronization time signal is transmitted from a grandmaster to other ports via periodic Announce messages. IEEE Std. 802.1AS™-2011 is normative and essential to implement an IEEE Std. 802.1Q Compliant System. IEEE Std. 802.1Q-2018 defines parameters, such as AdminBaseTime and OpenBaseTime, which are used to synchronize the clocks across the network.

<p>1.1 Project Number: P802.1Qbv 1.2 Type of Document: Standard 1.3 Life Cycle: Full Use</p> <hr/> <p>2.1 Title: Standard for Local and metropolitan area networks--Media Access Control (MAC) Bridges and Virtual Bridged Local Area Networks Amendment: Enhancements for Scheduled Traffic</p> <p>5.2.b. Scope of the project: This amendment specifies time-aware queue-draining procedures, managed objects and extensions to existing protocols that enable bridges and end stations to schedule the transmission of frames based on a synchronized time. Virtual Local Area Network (VLAN) tag encoded priority values are allocated allowing simultaneous support of scheduled traffic, credit-based shaper traffic and other bridged traffic over Local Area Networks (LANs).</p>
--

(Source: <http://www.ieee802.org/1/files/public/docs2014/bv-p802-1Qbv-par-modification-1114.pdf>)

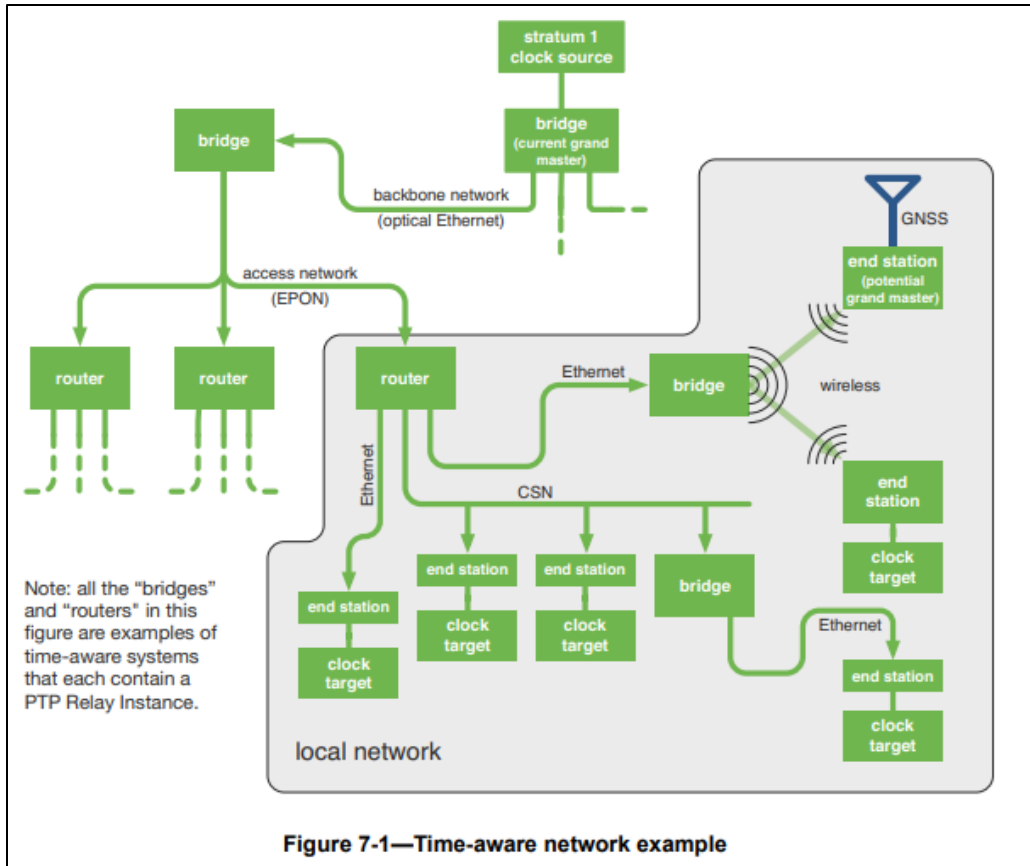

(Source: <https://1.ieee802.org/wp-content/uploads/2019/03/802-1AS-rev-d8-0.pdf>)

7.2 Architecture of a time-aware network

7.2.1 General

A time-aware network consists of a number of interconnected time-aware systems that support the gPTP defined within this standard. These time-aware systems can be any networking device, including, for example, bridges, routers, and end stations. A set of time-aware systems that are interconnected by gPTP-capable network elements is called a gPTP network. Each instance of gPTP that the time-aware systems support is in one gPTP domain, and the instances of gPTP are said to be part of that gPTP domain. A time-aware system can support, and therefore be part of, more than one gPTP domain. The entity of a single time-aware system that executes gPTP in one gPTP domain is called a PTP Instance. A time-aware system can contain multiple PTP Instances, which are each associated with a different gPTP domain. There are two

(Source: <https://1.ieee802.org/wp-content/uploads/2019/03/802-1AS-rev-d8-0.pdf>)

3.16 PTP End Instance: A PTP Instance that is capable of acting as the source of synchronized time on the network, or destination of synchronized time using the IEEE 802.1AS protocol, or both.

3.17 PTP Instance: A PTP Relay Instance or a PTP End Instance. A PTP Instance implements those portions of this standard indicated as applicable to a PTP Relay Instance or a PTP End Instance. Each PTP Instance operates in exactly one domain.

3.18 PTP Link: Within a domain, a network segment between two PTP Ports using the peer-to-peer delay mechanism of this standard. The peer-to-peer delay mechanism is designed to measure the propagation time over such a link.

NOTE—A PTP Link between PTP Ports of PTP Instances is also a gPTP Communication Path (see 3.9).

3.19 PTP Relay Instance: A PTP Instance that is capable of communicating synchronized time received on one port to other ports, using the IEEE 802.1AS protocol.

NOTE—A PTP Relay Instance could, for example, be contained in a bridge, a router, or a multi-port end station.

(Source: <https://1.ieee802.org/wp-content/uploads/2019/03/802-1AS-rev-d8-0.pdf>)

7.2.2 Time-aware network consisting of a single gPTP domain

Figure 7-1 illustrates an example time-aware network consisting of a single gPTP domain, using all the above network technologies (i.e., (c) - (f) of 7.2.1), where end stations on several local networks are connected to a grandmaster on a backbone network via an EPON access network.

Any PTP Instance with clock sourcing capabilities can be a potential grandmaster, so there is a selection method (the *best master clock algorithm*, or BMCA) that ensures that all of the PTP Instances in a gPTP domain use the same grandmaster.¹² The BMCA is largely identical to that used in IEEE Std 1588-2019,

(Source: <https://1.ieee802.org/wp-content/uploads/2019/03/802-1AS-rev-d8-0.pdf>)

10.3.1.1 Best master clock algorithm overview

In the BMCA (i.e., method (a) of 10.3.1), best master selection information is exchanged between PTP Instances of time-aware systems via Announce messages (see 10.5 and 10.6). Each Announce message contains time-synchronization spanning tree vector information that identifies one PTP Instance as the root of the time-synchronization spanning tree and, if the PTP Instance is grandmaster-capable, the grandmaster. Each PTP Instance in turn uses the information contained in the Announce messages it receives, along with its knowledge of itself, to compute which of the PTP Instances that it has knowledge of ought to be the root of the spanning tree and, if grandmaster-capable, the grandmaster. As part of constructing the time-synchronization spanning tree, each port of each PTP Instance is assigned a port state from Table 10-2 by state machines associated with the ports and with the PTP Instance as a whole.

(Source: <https://1.ieee802.org/wp-content/uploads/2019/03/802-1AS-rev-d8-0.pdf>)

c) In gPTP there are only two types of PTP Instances: PTP End Instances and PTP Relay Instances, while IEEE 1588 has ordinary clocks, boundary clocks, end-to-end transparent clocks, and P2P transparent clocks. A PTP End Instance corresponds to an IEEE 1588 ordinary clock, and a PTP Relay Instance is a type of IEEE 1588 boundary clock where its operation is very tightly defined, so much so that a PTP Relay Instance with Ethernet ports can be shown to be mathematically equivalent to a P2P transparent clock in terms of how synchronization is performed, as shown in

(Source: <https://1.ieee802.org/wp-content/uploads/2019/03/802-1AS-rev-d8-0.pdf>)

- **Grand Master selection**
 - GM-capable stations advertise themselves via ANNOUNCE messages
 - If a station hears from station with “better” clock, it does not send ANNOUNCE
 - Configurable “Priority” field can override clock quality
 - MAC address is tie breaker
 - Time relays drop all inferior ANNOUNCE messages
 - Forward only the best
 - Last one standing is Grand Master for the domain
 - GM is the root of the 802.1AS timing tree
 - GM periodically sends the current time

(Source: <https://avnu.org/wp-content/uploads/2014/05/as-kbstanton-8021AS-tutorial-0714-v01.pdf>)

IEEE Std 802.1Q-2018
IEEE Standard for Local and Metropolitan Area Networks—Bridges and Bridged Networks

2. Normative references

The following referenced documents are indispensable for the application of this document (i.e., they must be understood and used, so each referenced document is cited in the text and its relationship to this document is explained). For dated references, only the edition cited applies. For undated references, the latest edition of the referenced document (including any amendments or corrigenda) applies.

ANSI X3.159, American National Standards for Information Systems—Programming Language—C.⁵

IEEE Std 802[®], IEEE Standard for Local and metropolitan area networks: Overview and Architecture.^{6,7}

IEEE Std 802.1AB[™], IEEE Standard for Local and metropolitan area networks—Station and Media Access Control Connectivity Discovery.

IEEE Std 802.1AC[™], IEEE Standard for Local and metropolitan area networks—Media Access Control (MAC) Service Definition.

IEEE Std 802.1AE[™], IEEE Standard for Local and metropolitan area networks—Media Access Control (MAC) Security.

IEEE Std 802.1AS[™], IEEE Standard for Local and metropolitan area networks—Timing and Synchronization for Time-Sensitive Applications in Bridged Local Area Networks.

(Source: IEEE Standard for Local and metropolitan area networks— Bridges and Bridged Networks Amendment 25: Enhancements for Scheduled Traffic (IEEE 802.1Qbv-2015))

8.6.9.4.1 AdminBaseTime

The administrative value of base time, expressed as an IEEE 1588 precision time protocol (PTP) [B24] timescale (see 8.2 of IEEE Std 802.1AS[™]-2011 [B11]). This value can be changed by management, and is used by the List Config state machine (8.6.9.3) to set the value of OperBaseTime (8.6.9.4.18).

NOTE—Time is expressed in the PTP timescale as the number of seconds, nanoseconds, and fractional nanoseconds that have elapsed since 1 January 1970 00:00:00 TAI.

NOTE 2—If AdminBaseTime is set to the same time in the past in all bridges and end stations, OperBaseTime is always in the past, and all cycles start synchronized. Using AdminBaseTime in the past is appropriate when you can start schedules prior to starting the application that uses the schedules. Use of AdminBaseTime in the future is intended to change a currently running schedule in all bridges and end stations to a new schedule at a future time. Using AdminBaseTime in the future is appropriate when schedules must be changed without stopping the application.

(Source: IEEE Standard for Local and metropolitan area networks— Bridges and Bridged Networks Amendment 25: Enhancements for Scheduled Traffic (IEEE 802.1Qbv-2015))

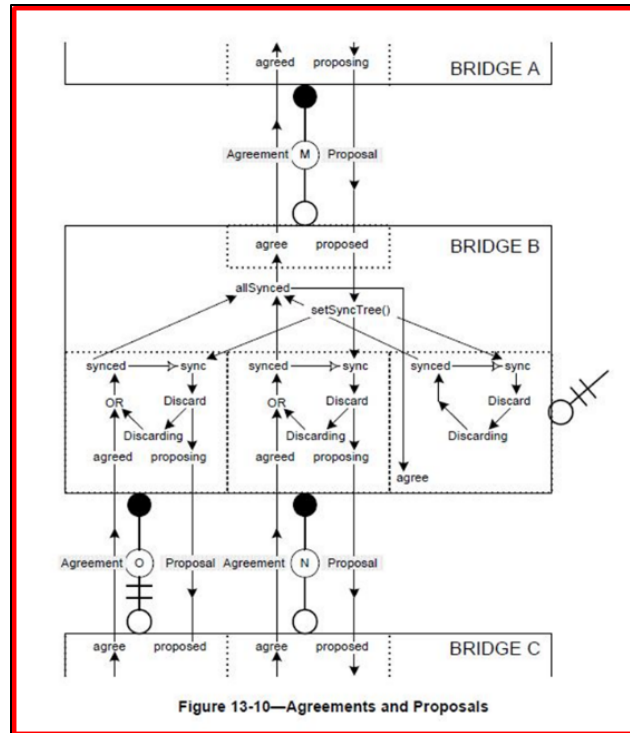

(Source: IEEE Standard for Local and Metropolitan Area Networks—Bridges and Bridged Networks- IEEE Std 802.1Q™-2018)

NOTE 2—Agreements can be generated without prior receipt of a Proposal as soon as the necessary conditions are met. Subsequent receipt of a Proposal serves to elicit a further Agreement. If all other ports have already been synchronized (allSynced in Figure 13-10) and the Proposal's priority vector does not convey worse information, synchronization is maintained and there is no need to transition Designated Ports to Discarding once more, or to transmit further Proposals.

(Source: IEEE Standard for Local and Metropolitan Area Networks—Bridges and Bridged Networks- IEEE Std 802.1Q™-2018)

60. The methods practiced by NEC's use of the accused products include maintaining a substantially synchronized time frame among the plurality of device adapters interconnected by a network, the time frame repeating periodically and including a plurality of assigned time

phases and a free access phase. For example, the accused products are used by NEC to implement the IEEE 802.1Q standard. The time aware bridged LAN uses 802.1AS base time to maintain synchronized time for all the ports in the bridges (device adapters). The bridges containing ports schedule the transmission of traffic based on the synchronized time. Each port associated with a specific set of transmission queues includes a plurality of transmission gates. A transmission gate can be in a closed state or open state. The functionality of assigned time phases is achieved using open gates transmitting data packets during transmission time. The functionality of free access phase is achieved when the gates are opened for transmission during any time. IEEE Std. 802.1Q-2018 supports cyclic queuing and forwarding structures to create synchronized frames and gates which repeat periodically (Annex T).

1.1 Project Number: P802.1Qbv

1.2 Type of Document: Standard

1.3 Life Cycle: Full Use

2.1 Title: Standard for Local and metropolitan area networks--Media Access Control (MAC) Bridges and Virtual Bridged Local Area Networks Amendment: Enhancements for Scheduled Traffic

5.2.b. Scope of the project: This amendment specifies time-aware queue-draining procedures, managed objects and extensions to existing protocols that enable bridges and end stations to schedule the transmission of frames based on a synchronized time. Virtual Local Area Network (VLAN) tag encoded priority values are allocated allowing simultaneous support of scheduled traffic, credit-based shaper traffic and other bridged traffic over Local Area Networks (LANs).

(Source: <http://www.ieee802.org/1/files/public/docs2014/bv-p802-1Qbv-par-modification-1114.pdf>)

- **Grand Master selection**
 - GM-capable stations advertise themselves via ANNOUNCE messages
 - If a station hears from station with “better” clock, it does not send ANNOUNCE
 - Configurable “Priority” field can override clock quality
 - MAC address is tie breaker
 - Time relays drop all inferior ANNOUNCE messages
 - Forward only the best
 - Last one standing is Grand Master for the domain
 - GM is the root of the 802.1AS timing tree
 - GM periodically sends the current time

(Source: <https://avnu.org/wp-content/uploads/2014/05/as-kbstanton-8021AS-tutorial-0714-v01.pdf>)

3.16 PTP End Instance: A PTP Instance that is capable of acting as the source of synchronized time on the network, or destination of synchronized time using the IEEE 802.1AS protocol, or both.

3.17 PTP Instance: A PTP Relay Instance or a PTP End Instance. A PTP Instance implements those portions of this standard indicated as applicable to a PTP Relay Instance or a PTP End Instance. Each PTP Instance operates in exactly one domain.

3.18 PTP Link: Within a domain, a network segment between two PTP Ports using the peer-to-peer delay mechanism of this standard. The peer-to-peer delay mechanism is designed to measure the propagation time over such a link.

NOTE—A PTP Link between PTP Ports of PTP Instances is also a gPTP Communication Path (see 3.9).

3.19 PTP Relay Instance: A PTP Instance that is capable of communicating synchronized time received on one port to other ports, using the IEEE 802.1AS protocol.

NOTE—A PTP Relay Instance could, for example, be contained in a bridge, a router, or a multi-port end station.

(Source: <https://1.ieee802.org/wp-content/uploads/2019/03/802-1AS-rev-d8-0.pdf>)

8.6.8.4 Enhancements for scheduled traffic

A Bridge or an end station may support enhancements that allow transmission from each queue to be scheduled relative to a known timescale. In order to achieve this, a transmission gate is associated with each queue; the state of the transmission gate determines whether or not queued frames can be selected for transmission (see Figure 8-12). For a given queue, the transmission gate can be in one of two states:

- a) Open: Queued frames are selected for transmission, in accordance with the definition of the transmission selection algorithm associated with the queue.
- b) Closed: Queued frames are not selected for transmission.

(Source: IEEE Standard for Local and metropolitan area networks— Bridges and Bridged Networks Amendment 25: Enhancements for Scheduled Traffic (IEEE 802.1Qbv-2015))

8.6.8 Transmission selection

For each Port, frames are selected for transmission on the basis of the traffic classes that the Port supports and the operation of the transmission selection algorithms supported by the corresponding queues on that Port. For a given Port and traffic class, frames are selected from the corresponding queue for transmission if and only if

- a) The operation of the transmission selection algorithm supported by that queue determines that there is a frame available for transmission; and
- b) For each queue corresponding to a numerically higher value of traffic class supported by the Port, the operation of the transmission selection algorithm supported by that queue determines that there is no frame available for transmission.

(Source: IEEE Standard for Local and Metropolitan Area Networks—Bridges and Bridged Networks- IEEE Std 802.1Q™-2018)

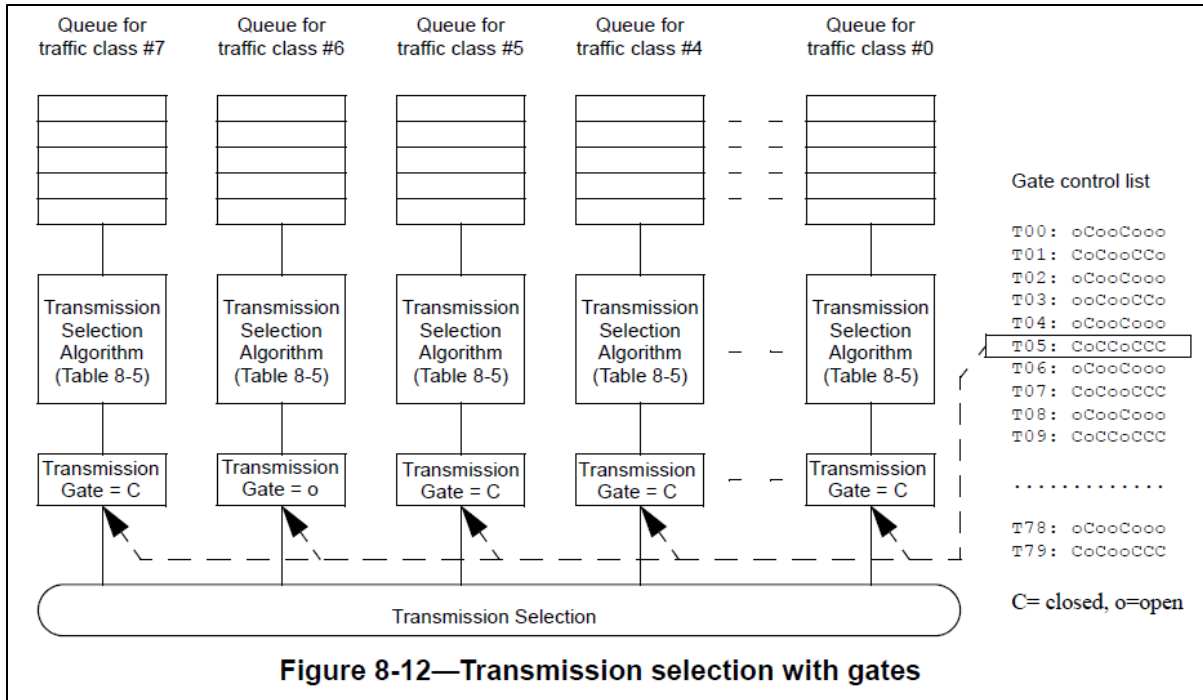

(Source: IEEE Standard for Local and metropolitan area networks— Bridges and Bridged Networks Amendment 25: Enhancements for Scheduled Traffic (IEEE 802.1Qbv-2015))

A gate control list associated with each Port contains an ordered list of gate operations. Each gate operation changes the transmission gate state for the gate associated with each of the Port’s traffic class queues. In an implementation that does not support enhancements for scheduled traffic, all gates are assumed to be permanently in the open state. Table 8-6 identifies the gate operation types, their parameters, and the actions that result from their execution. The state machines that control the execution of the gate control list, along with their variables and procedures, are specified in 8.6.9.

(Source: IEEE Standard for Local and metropolitan area networks— Bridges and Bridged Networks Amendment 25: Enhancements for Scheduled Traffic (IEEE 802.1Qbv-2015))

3.3 gating cycle: The period of time over which the sequence of operations in a gate control list repeats.

3.4 transmission gate: A gate that connects or disconnects the transmission selection function of the forwarding process from the queue, allowing or preventing it from selecting frames from that queue. The gate has two states, Open and Closed.

(Source: IEEE Standard for Local and metropolitan area networks— Bridges and Bridged Networks Amendment 25: Enhancements for Scheduled Traffic (IEEE 802.1Qbv-2015))

Cyclic queuing and forwarding⁵³

T.1 Overview of CQF

Cyclic queuing and forwarding (CQF) is a method of traffic shaping that can deliver deterministic, and easily calculated, latency for time-sensitive traffic streams. As the name implies, the principle underlying CQF is that stream traffic is transmitted and queued for transmission along a network path in a cyclic manner. Time is divided into numbered time intervals $i, i+1, i+2, \dots, i+N$, each of duration d . Frames transmitted by a Bridge, *Alice*, during time interval i are received by a downstream Bridge, *Bob*, during time interval i and are transmitted onwards by *Bob* towards Bridge *Charlie* during time interval $i+1$, and so on. A starting assumption is that, for a given traffic class, all Bridges and all end stations connected to a given bridge have a common understanding (to a known accuracy) of the start time of cycle i , and the cycle duration, d .

Frames transmitted by *Alice* during interval i are transmitted by *Bob* in interval $i+1$; the maximum possible delay experienced by a given frame is from the beginning of i to the end of $i+1$, or twice d . Similarly, the minimum possible delay experienced is from the end of i to the beginning of $i+1$, which is zero. More generally, the maximum delay experienced by a given frame is

$$(h+1) \times d$$

and the minimum delay experienced by a given frame is

$$(h-1) \times d$$

where h is the number of hops.

(Source: IEEE Standard for Local and Metropolitan Area Networks—Bridges and Bridged Networks- IEEE Std 802.1Q™-2018)

61. The methods practiced by NEC's use of the accused products include assigning each time phase to a specific device adapter prior to transmission of real-time data by the specific device adapter. For example, the accused products are used by NEC to implement the IEEE 802.1Q standard. IEEE standard 802.1Q shows that scheduling (assigning) of transmission gates starts prior to the transmission of real-time data. Per clause 8.6.8 of the IEEE Std. 802.1Q, each time phase is assigned to a specific device adapter prior to transmission of real-time data by the specific device adapter. IEEE 802.1Q performs traffic shaping through Per-Stream Filtering and Policing (PSTP).

NOTE 2—If AdminBaseTime is set to the same time in the past in all bridges and end stations. OperBaseTime is always in the past, and all cycles start synchronized. Using AdminBaseTime in the past is appropriate when you can start schedules prior to starting the application that uses the schedules. Use of AdminBaseTime in the future is intended to

(Source: IEEE Standard for Local and metropolitan area networks— Bridges and Bridged Networks Amendment 25: Enhancements for Scheduled Traffic (IEEE 802.1Qbv-2015))

<p>1.1 Project Number: P802.1Qbv 1.2 Type of Document: Standard 1.3 Life Cycle: Full Use</p> <p>5.5 Need for the Project: The credit-based shaper works well in arbitrary networks (i.e., non-engineered). <u>Networks employing scheduled transmissions are able to control real-time processes.</u> This amendment enables those two kinds of networks to be consolidated into a single network, with a significant cost reduction to the user.</p>

(Source: <http://www.ieee802.org/1/files/public/docs2014/bv-p802-1Qbv-par-modification-1114.pdf>)

<p>8.6.8 Transmission selection</p> <p>For each Port, <u>frames are selected for transmission on the basis of the traffic classes that the Port supports</u> and the operation of the transmission selection algorithms supported by the corresponding queues on that Port. For a given Port and traffic class, <u>frames are selected from the corresponding queue for transmission if and only if</u></p> <ol style="list-style-type: none">The operation of the transmission selection algorithm supported by that queue determines that there is a frame available for transmission; andFor each queue corresponding to a numerically higher value of traffic class supported by the Port, the operation of the transmission selection algorithm supported by that queue determines that there is no frame available for transmission.
--

(Source: IEEE Standard for Local and Metropolitan Area Networks—Bridges and Bridged Networks- IEEE Std 802.1Q™-2018)

<p>5.4.1.9 Cyclic queuing and forwarding (CQF) requirements</p> <p>A VLAN Bridge component implementation that conforms to the provisions of this standard for CQF (see Annex T) shall</p> <ol style="list-style-type: none">Support the enhancements for scheduled traffic as specified in 8.6.8.4.Support the state machines for scheduled traffic as specified in 8.6.9.Support the state machines for stream gate control as specified in 8.6.10.Support the management entities for scheduled traffic as specified in 12.29.Support the <u>requirements for per-stream filtering and policing (PSFP) as stated in 5.4.1.8.</u>Support the management entities for PSFP as specified in 12.31.
--

(Source: IEEE Standard for Local and Metropolitan Area Networks—Bridges and Bridged Networks- IEEE Std 802.1Q™-2018)

5.4.1.5 Forwarding and Queuing Enhancements for time-sensitive streams (FQTSS)—requirements

A VLAN Bridge component implementation that conforms to the provisions of this standard for FQTSS shall

- a) Support a minimum of two traffic classes on all Ports, of which
 - 1) A minimum of one traffic class supports the strict priority algorithm for transmission selection (8.6.8.1), and
 - 2) One traffic class is a stream reservation (SR) class.
- b) Support the operation of the credit-based shaper algorithm (8.6.8.2) on all Ports as the transmission selection algorithm used for the SR class.
- c) Support SRP domain boundary port priority regeneration override as defined in 6.9.4, and the default priority regeneration override value defined in Table 6-5, for SR class “B.”
- d) Support the tables and procedures for mapping priorities to traffic classes as defined in 34.5.

SR: Stream Reservation, SRP: Stream Reservation Protocol

(Source: IEEE Standard for Local and Metropolitan Area Networks—Bridges and Bridged Networks- IEEE Std 802.1Q™-2018)

62. The plurality of device adaptors recited above in connection with NEC’s use of the accused products includes a respective one of the plurality of device adaptors that is configured to transmit data during at least one of a respective assigned time phase or the free access phase, to refrain from transmitting data during time phases not assigned to the respective one of the plurality of device adaptors, and to determine whether to defer transmission of data during at least one of the assigned time phase or the free access phase to allow a non-real time device to transmit data. For example, the accused products are used by NEC to implement the IEEE 802.1Q standard. IEEE standard 802.1Q implements a method in which open gates transmit data packets during transmission time and closed gates refrain data packets from transmission. The functionality of assigned time phases is achieved using open gates transmitting data packets during transmission time. The functionality of free access phase is achieved by the gates that are opened for transmission during any time. IEEE Std. 802.1Q supports Forwarding and Queuing Enhancements for Time Sensitive Streams. Thus, one of the plurality of device adaptors is configured to transmit data during at least one of a respective assigned time phase or

free access phase, to refrain from transmitting data during time phases not assigned to the respective one of the plurality of device adapters. IEEE Std. 802.1Q provides traffic shaping for various classes of data transmission and determining whether to defer transmission of data during at least one of the assigned time phase or the free access phase to allow a non-real time device to transmit data.

8.6.8.4 Enhancements for scheduled traffic

A Bridge or an end station may support enhancements that allow transmission from each queue to be scheduled relative to a known timescale. In order to achieve this, a transmission gate is associated with each queue; the state of the transmission gate determines whether or not queued frames can be selected for transmission (see Figure 8-12). For a given queue, the transmission gate can be in one of two states:

- a) *Open*: Queued frames are selected for transmission, in accordance with the definition of the transmission selection algorithm associated with the queue.
- b) *Closed*: Queued frames are not selected for transmission.

(Source: IEEE Standard for Local and metropolitan area networks— Bridges and Bridged Networks Amendment 25: Enhancements for Scheduled Traffic (IEEE 802.1Qbv-2015))

A *gate control list* associated with each Port contains an ordered list of gate operations. Each gate operation changes the transmission gate state for the gate associated with each of the Port's traffic class queues. In an implementation that does not support enhancements for scheduled traffic, all gates are assumed to be permanently in the *open* state. Table 8-6 identifies the gate operation types, their parameters, and the actions that result from their execution. The state machines that control the execution of the gate control list, along with their variables and procedures, are specified in 8.6.9.

(Source: IEEE Standard for Local and metropolitan area networks— Bridges and Bridged Networks Amendment 25: Enhancements for Scheduled Traffic (IEEE 802.1Qbv-2015))

5.4.1.5 Forwarding and Queuing Enhancements for time-sensitive streams (FQTSS)—requirements

A VLAN Bridge component implementation that conforms to the provisions of this standard for FQTSS shall

- a) Support a minimum of two traffic classes on all Ports, of which
 - 1) A minimum of one traffic class supports the strict priority algorithm for transmission selection (8.6.8.1), and
 - 2) One traffic class is a stream reservation (SR) class.
- b) Support the operation of the credit-based shaper algorithm (8.6.8.2) on all Ports as the transmission selection algorithm used for the SR class.
- c) Support SRP domain boundary port priority regeneration override as defined in 6.9.4, and the default priority regeneration override value defined in Table 6-5, for SR class “B.”
- d) Support the tables and procedures for mapping priorities to traffic classes as defined in 34.5.

SR: Stream Reservation, SRP: Stream Reservation Protocol

(Source: IEEE Standard for Local and Metropolitan Area Networks—Bridges and Bridged Networks- IEEE Std 802.1Q™-2018)

5.4.1.6 ETS Bridge requirements

A device supporting ETS shall

- a) Support at least 3 traffic classes (37.3).

NOTE—A minimum of 3 traffic classes allows a minimum configuration such that one traffic class contains priorities with PFC enabled, one traffic class contains priorities with PFC disabled, and one traffic class using strict priority.

- b) Support bandwidth configuration with a granularity of 1% or finer (37.3).
- c) Support bandwidth allocation with a precision of 10% (37.3).
- d) Support a transmission selection policy such that if one of the traffic classes does not consume its allocated bandwidth, then any unused bandwidth is available to other traffic classes (37.3).
- e) Support DCBX (Clause 38).

(Source: IEEE Standard for Local and Metropolitan Area Networks—Bridges and Bridged Networks- IEEE Std 802.1Q™-2018)

63. NEC has had knowledge of the ‘053 Patent at least as of the date when it was notified of the filing of this action.

64. Far North Patents has been damaged as a result of the infringing conduct by NEC alleged above. Thus, NEC is liable to Far North Patents in an amount that adequately compensates it for such infringements, which, by law, cannot be less than a reasonable royalty, together with interest and costs as fixed by this Court under 35 U.S.C. § 284.

65. Far North Patents and/or its predecessors-in-interest have satisfied all statutory obligations required to collect pre-filing damages for the full period allowed by law for infringement of the '053 Patent.

COUNT V

DIRECT INFRINGEMENT OF U.S. PATENT NO. 6,246,702

66. On June 12, 2001, United States Patent No. 6,246,702 (“the ‘702 Patent”) was duly and legally issued by the United States Patent and Trademark Office for an invention entitled “Methods and Apparatus for Providing Quality-of-Service Guarantees in Computer Networks.”

67. Far North Patents is the owner of the ‘702 Patent, with all substantive rights in and to that patent, including the sole and exclusive right to prosecute this action and enforce the ‘702 Patent against infringers, and to collect damages for all relevant times.

68. NEC made, had made, used, imported, provided, supplied, distributed, sold, and/or offered for sale products and/or systems including, for example, its NEC QX-S1000, QX-S4100, and QX-S5200 Series PoE+ Gigabit Ethernet Switch families of products that include advanced quality of service capabilities (collectively, “accused products”).



(Source : <https://www.nec-enterprise.com/documents?id=1231&hash=ee65e0bee7d7c9fdc17193aebcca809e2a295fa56a3f8eae7b654c497b1afa1>)

Specifications

Features		S1008GT-2G-PW	S1016GT-4G-PW	S1024GT-4G-PW	
Performance	Switching capacity [bps]	20.0G	40.0G	56.0G	
	Transfer rate [pps]	14.8M	29.7M	41.6M	
	Switching method	S&F			
	MAC address table	8K			
	Routing table (IPv4/IPv6)	-			
	ARP table	32			
Interface	1Gbe	10/100-1000BASE-T	8	16	24
		SFP slot	2	4	4
	Console Port		√	√	√
PoE+	Number of power feedable interfaces	8	16	24	
	Power feeding standard	IEEE802.3af/at			
	Maximum power supply amount per port	30.0W			
	Maximum power supply amount per device	65.0W	124.0W	180.0W	
IRF	IRF stack version	-			
	Maximum number of IRF stacks	-			
	MAD/ISSU	-			
VLAN	IEEE802.1Q	√			
	Port VLAN	√			
	Protocol VLAN	-			
	Voice VLAN	√			
	Max. number of VLAN	4094			
	VLAN mapping	-			
	QinQ	-			

(Source : <https://www.nec-enterprise.com/documents?id=1231&hash=ee65e0bee7d7c9fdc17193aebcca809e2a295fa56a3f8eae7b654c497b1afa1>)

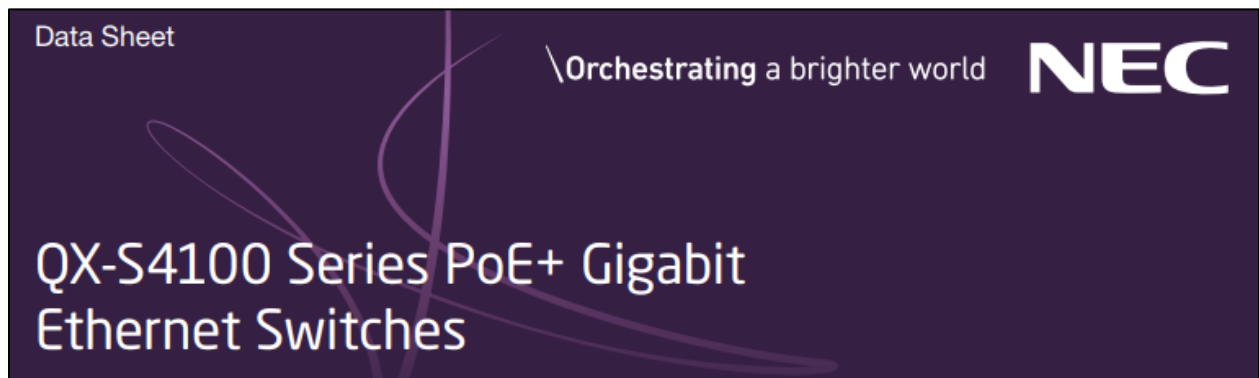

(Source : <https://www.necam.com/docs/?id=d424b393-56d0-44b0-92e1-59e10359ed91>)

Specifications		S4108GT-2G-PW	S4116GT-4G-PW	S4124GT-4G-PW	S4148GT-4G-PW	
Performance	Switching capacity [bps]	20.0G	40.0G	56.0G	104.0G	
	Transfer rate [pps]	14.8M	29.7M	41.6M	77.3M	
	Switching method	S&F				
	MAC address table	16K				
	Routing table (IPv4/IPv6)	64/64				
	ARP table	256				
Interface	1Gbe	10/100-1000BASE-T	8	16	28	48
		SFP slot	2	4	4c	4
	Console Port	✓	✓	✓	✓	
PoE+	Number of power feedable interfaces	8	16	24	48	
	Power feeding standard	IEEE802.3at				
	Maximum power supply amount per port	30.0W				
	Maximum power supply amount per device	125.0W	170.0W	370.0W		
IRF	IRF stack version	IRFv2				
	Maximum number of IRF stacks	4				
	MAD/ISSU	✓ / -				
VLAN	IEEE802.1Q	✓				
	Port VLAN	✓				
	Protocol VLAN	✓				
	Voice VLAN	✓				
	Maximum number of VLAN [number of settable IP addresses]	4094[32]				
	VLAN mapping	✓				

(Source : <https://www.necam.com/docs/?id=d424b393-56d0-44b0-92e1-59e10359ed91>)

S-0301
October 24, 2019

QX-S1000 Ethernet Switch Family

NEC Corporation of America (NEC) offers a diverse range of **commercial-grade** switches:

- QX-S1000 and QX-S4100 product lines for SMB applications
- QX-S5200 product line of access switches for larger, Enterprise applications
- QX-S6600 product line for aggregation in Enterprise networking.

These product lines include non-PoE switches for data applications as well as PoE+ switches that can supply power to SL2100 IP phones, access points and other IoT devices). QX switches can be managed by the SDN Controller, WebGUI management console, or Command Line Interface (CLI).

We are happy to announce that the entire QX family of switches is now available through our Distributor network.

(Source : <http://ntsdirect.com/wp-content/uploads/2019/12/QX-S1000-Ethernet-Switch-Family-1.pdf>)



(Source : https://s3.eu-central-1.amazonaws.com/z3r2zxopa4uuqpw5a4ju/sdnospace/files/pdf/datasheet-NEC-Qx%20S5200%20PoE%2010G%20Switch_eng%202018-v01.pdf)

Specifications			S5224GT-4X-PW	S5248GT-4X-PW
Performance	Switching capacity [bps]		128.0G	176.0G
	Transfer rate [pps]		95.2M	130.9M
	Switching method			S&F
	MAC address table			16K
	Routing table (IPv4/IPv6)			512/256
Interface	ARP table			1K
	10Gbe	SFP slot	-	-
		SFP+ slot	4	4
	40Gbe	QSFP+ slot	-	-
		Console Port	√	√
PoE+	Number of power feedable interfaces		24	48
	Power feeding standard			IEEE802.3at
	Maximum power supply amount per port			30.0W
	Maximum power supply amount per device			370.0W
IRF	IRF stack version			IRFv2
	Maximum number of IRF stacks			6
	MAD/ISSU			√/ -
VLAN	IEEE802.1Q			√
	Port VLAN			√
	Protocol VLAN			√
	Voice VLAN			√
	Max. number of VLAN [number of settable IP addresses]			4094[32]
	VLAN mapping			√
	QinQ			√
	Auto Negotiation/fixed speed and duplex (full/half)			√/√
	Auto MDI • MDIX/ fixed MDIX			√/√
	Flow control (IEEE802.3X)			√
EAP transmitted/BPDU transmitted			√/√	
Port isolate			√	
Packet transfer suppression			B/M/U	

(Source : https://s3.eu-central-1.amazonaws.com/z3r2zxopa4uuqpw5a4ju/sdnospace/files/pdf/datasheet-NEC-Qx%20S5200%20PoE%2010G%20Switch_eng%202018-v01.pdf)

69. By doing so, NEC has directly infringed (literally and/or under the doctrine of equivalents) at least Claim 27 of the '702 Patent. NEC's infringement in this regard is ongoing.

70. NEC has infringed the '702 Patent by using the accused products and thereby practicing a method for regulating traffic in an Ethernet network including real-time devices, non-real-time devices, a network medium, and a plurality of device adapters connected between the devices and the network medium, each of the device adapters including a clock. For example, the accused products are used by NEC to implement the IEEE 802.1Q standard. IEEE standard 802.1Q (Qbv) implements a method for scheduling traffic in time aware Local Area Network (Ethernet network). The time aware network includes multiple end points (devices) and bridges that includes ports (device adapters). The endpoint and bridges are connected via interconnects (network medium). Also, each time aware bridge including port is a boundary clock. The endpoints transmit data that is a mix of time-critical traffic and other traffic, i.e, real time data and non-real time data. The end point is either a real time device or a non-real time device. IEEE Std. 802.1AS™ is normative and essential to implement an IEEE Std. 802.1Q Compliant System.

1.1 Project Number: P802.1Qbv
1.2 Type of Document: Standard
1.3 Life Cycle: Full Use

2.1 Title: Standard for Local and metropolitan area networks--Media Access Control (MAC) Bridges and Virtual Bridged Local Area Networks Amendment: Enhancements for Scheduled Traffic

5.2.b. Scope of the project: This amendment specifies time-aware queue-draining procedures, managed objects and extensions to existing protocols that enable bridges and end stations to schedule the transmission of frames based on a synchronized time. Virtual Local Area Network (VLAN) tag encoded priority values are allocated allowing simultaneous support of scheduled traffic, credit-based shaper traffic and other bridged traffic over Local Area Networks (LANs).

(Source: <http://www.ieee802.org/1/files/public/docs2014/bv-p802-1Qbv-par-modification-1114.pdf>)

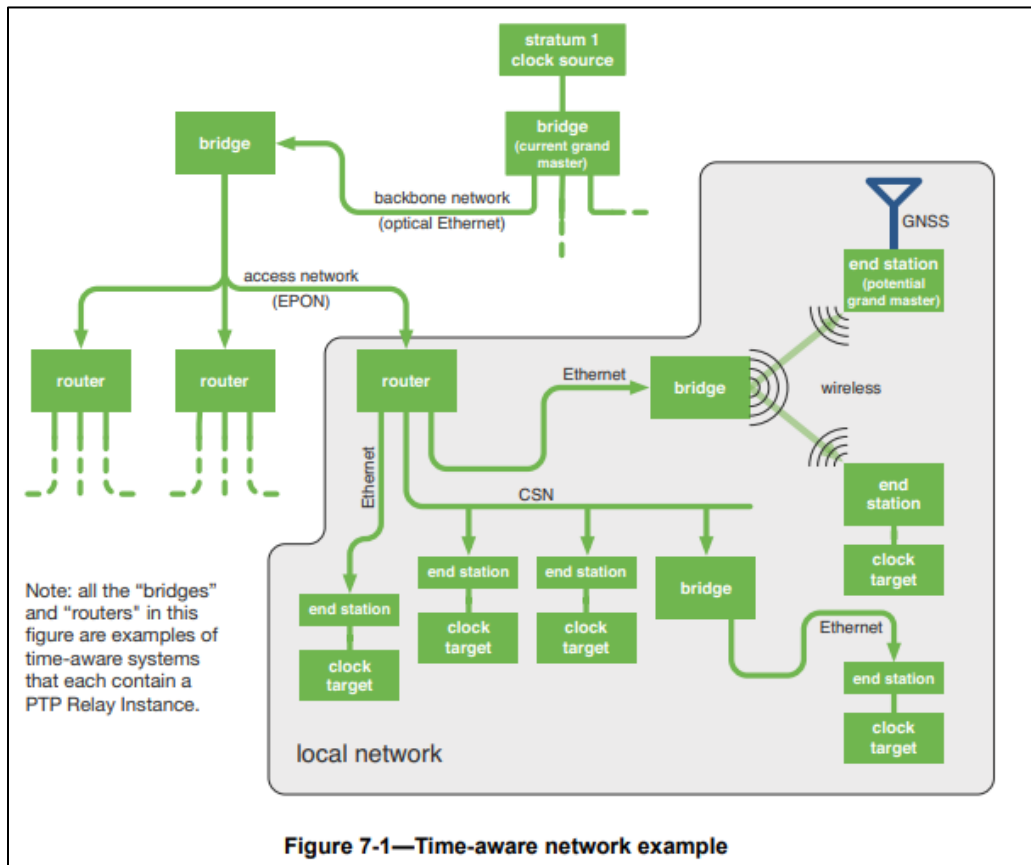

(Source: <https://1.ieee802.org/wp-content/uploads/2019/03/802-1AS-rev-d8-0.pdf>)

7.2 Architecture of a time-aware network

7.2.1 General

A time-aware network consists of a number of interconnected time-aware systems that support the gPTP defined within this standard. These time-aware systems can be any networking device, including, for example, bridges, routers, and end stations. A set of time-aware systems that are interconnected by gPTP-capable network elements is called a gPTP network. Each instance of gPTP that the time-aware systems support is in one gPTP domain, and the instances of gPTP are said to be part of that gPTP domain. A time-aware system can support, and therefore be part of, more than one gPTP domain. The entity of a single time-aware system that executes gPTP in one gPTP domain is called a PTP Instance. A time-aware system can contain multiple PTP Instances, which are each associated with a different gPTP domain. There are two

(Source: <https://1.ieee802.org/wp-content/uploads/2019/03/802-1AS-rev-d8-0.pdf>)

- c) In gPTP there are only two types of PTP Instances: PTP End Instances and PTP Relay Instances, while IEEE 1588 has ordinary clocks, boundary clocks, end-to-end transparent clocks, and P2P transparent clocks. A PTP End Instance corresponds to an IEEE 1588 ordinary clock, and a PTP Relay Instance is a type of IEEE 1588 boundary clock where its operation is very tightly defined, so much so that a PTP Relay Instance with Ethernet ports can be shown to be mathematically equivalent to a P2P transparent clock in terms of how synchronization is performed, as shown in

(Source: <https://1.ieee802.org/wp-content/uploads/2019/03/802-1AS-rev-d8-0.pdf>)

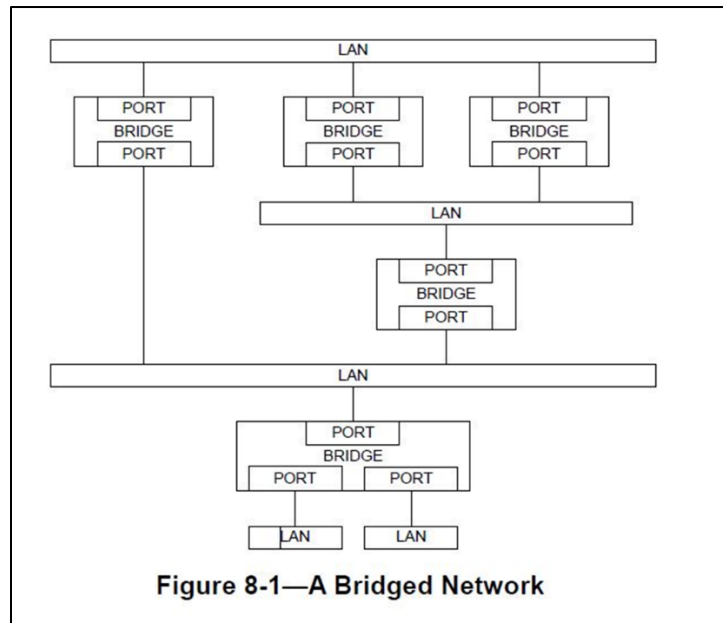

(Source: IEEE Standard for Local and Metropolitan Area Networks—Bridges and Bridged Networks- IEEE Std 802.1Q™-2018)

Traffic scheduling

This annex provides some background to the mechanisms provided in this standard for traffic scheduling, with the intent of providing some insight into the motivation for the provision of mechanisms for traffic scheduling and some of the ways that the mechanisms might be used.

Q.1 Motivation

Some applications have a need for frame delivery that is highly predictable in terms of the time at which frame transmission will occur, and the overall latency and jitter that will be experienced as the frame is propagated to its destination. Examples include industrial and automotive control applications, where data transmitted over the network is used to feed the parameters of control loops that are critical to the operation of the plant or machinery involved, and where frames carrying control data are transmitted on a repeating time schedule; late delivery of such frames can result in instability, inaccuracy, or failure of the operation of the control loops concerned. In some implementations, this need has been met by the provision of dedicated, highly engineered networks that are used solely for the transmission of time-critical control traffic; however, as the bandwidth occupied by such traffic is often low, and the cost of providing a dedicated control network can be high, it can be desirable to mix time-critical traffic with other classes of traffic in the same network, as long as such mixing can be achieved while still meeting the timing requirements of the time-critical traffic.

(Source: IEEE Standard for Local and metropolitan area networks— Bridges and Bridged Networks Amendment 25: Enhancements for Scheduled Traffic (IEEE 802.1Qbv-2015))

IEEE Std 802.1Q-2018 IEEE Standard for Local and Metropolitan Area Networks—Bridges and Bridged Networks
<h2><u>2. Normative references</u></h2> <p>The following referenced documents are indispensable for the application of this document (i.e., they must be understood and used, so each referenced document is cited in the text and its relationship to this document is explained). For dated references, only the edition cited applies. For undated references, the latest edition of the referenced document (including any amendments or corrigenda) applies.</p> <p>ANSI X3.159, American National Standards for Information Systems—Programming Language—C.⁵</p> <p>IEEE Std 802[®], IEEE Standard for Local and metropolitan area networks: Overview and Architecture.^{6,7}</p> <p>IEEE Std 802.1AB[™], IEEE Standard for Local and metropolitan area networks—Station and Media Access Control Connectivity Discovery.</p> <p>IEEE Std 802.1AC[™], IEEE Standard for Local and metropolitan area networks—Media Access Control (MAC) Service Definition.</p> <p>IEEE Std 802.1AE[™], IEEE Standard for Local and metropolitan area networks—Media Access Control (MAC) Security.</p> <p><u>IEEE Std 802.1AS[™], IEEE Standard for Local and metropolitan area networks—Timing and Synchronization for Time-Sensitive Applications in Bridged Local Area Networks.</u></p>

(Source: IEEE Standard for Local and Metropolitan Area Networks—Bridges and Bridged Networks- IEEE Std 802.1Q™-2018)

71. The methods practiced by NEC's use of the accused products include defining a common time reference for the device adapters, said common time reference including a frame of time having a plurality of time phases, each of device adapters being uniquely assigned to one of said plurality of time phases, said plurality of time phases including a free-access phase. For example, the accused products are used by NEC to implement the IEEE 802.1Q standard. The time aware bridged LAN use 802.1AS base time to maintain synchronized time (common time reference) for all the ports in the bridges (device adapters). The bridges containing ports schedule the transmission of traffic based on the synchronized time. Each port associated with a specific set of transmission queues includes a plurality of transmission gates. A transmission gate can be in a closed state or open state. The functionality of assigned time phases is achieved using open gates transmitting data packets during transmission time. The functionality of free access phase is achieved when the gates are opened for transmission during any time.

1.1 Project Number: P802.1Qbv

1.2 Type of Document: Standard

1.3 Life Cycle: Full Use

2.1 Title: Standard for Local and metropolitan area networks--Media Access Control (MAC) Bridges and Virtual Bridged Local Area Networks Amendment: Enhancements for Scheduled Traffic

5.2.b. Scope of the project: This amendment specifies time-aware queue-draining procedures, managed objects and extensions to existing protocols that enable bridges and end stations to schedule the transmission of frames based on a synchronized time. Virtual Local Area Network (VLAN) tag encoded priority values are allocated allowing simultaneous support of scheduled traffic, credit-based shaper traffic and other bridged traffic over Local Area Networks (LANs).

(Source: <http://www.ieee802.org/1/files/public/docs2014/bv-p802-1Qbv-par-modification-1114.pdf>)

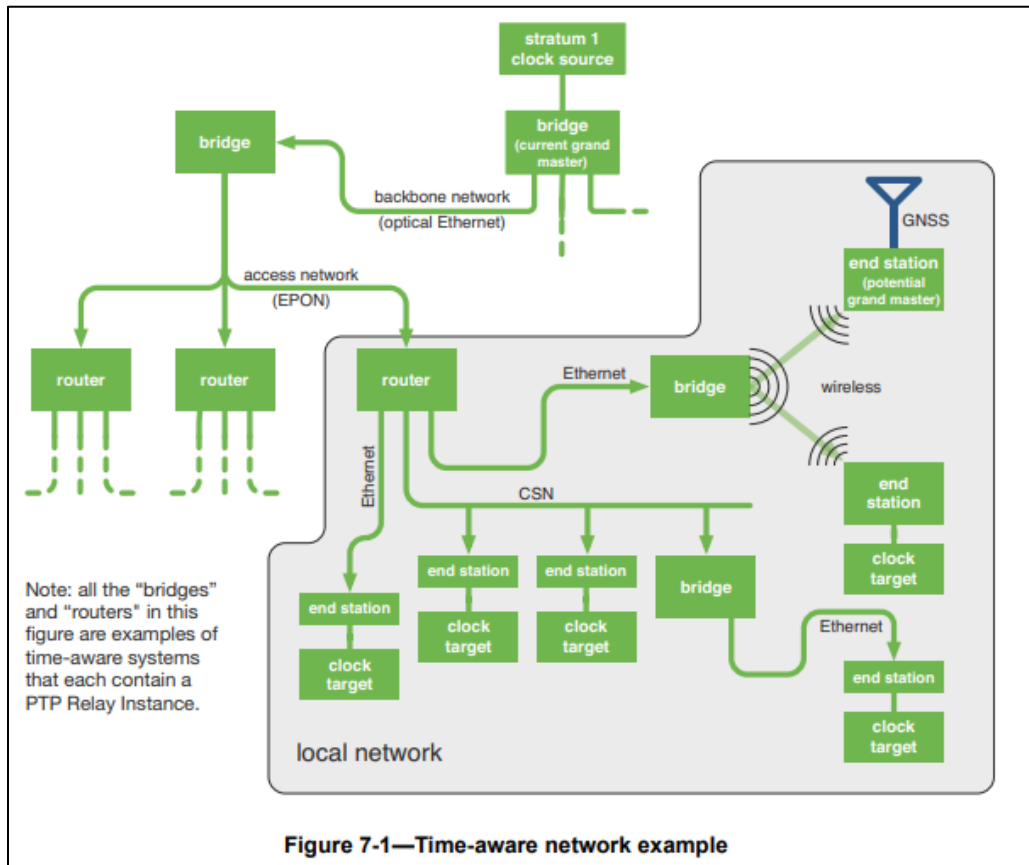

(Source: <https://1.ieee802.org/wp-content/uploads/2019/03/802-1AS-rev-d8-0.pdf>)

3.16 PTP End Instance: A PTP Instance that is capable of acting as the source of synchronized time on the network, or destination of synchronized time using the IEEE 802.1AS protocol, or both.

3.17 PTP Instance: A PTP Relay Instance or a PTP End Instance. A PTP Instance implements those portions of this standard indicated as applicable to a PTP Relay Instance or a PTP End Instance. Each PTP Instance operates in exactly one domain.

3.18 PTP Link: Within a domain, a network segment between two PTP Ports using the peer-to-peer delay mechanism of this standard. The peer-to-peer delay mechanism is designed to measure the propagation time over such a link.

NOTE—A PTP Link between PTP Ports of PTP Instances is also a gPTP Communication Path (see 3.9).

3.19 PTP Relay Instance: A PTP Instance that is capable of communicating synchronized time received on one port to other ports, using the IEEE 802.1AS protocol.

NOTE—A PTP Relay Instance could, for example, be contained in a bridge, a router, or a multi-port end station.

(Source: <https://1.ieee802.org/wp-content/uploads/2019/03/802-1AS-rev-d8-0.pdf>)

8.6.8.4 Enhancements for scheduled traffic

A Bridge or an end station may support enhancements that allow transmission from each queue to be scheduled relative to a known timescale. In order to achieve this, a transmission gate is associated with each queue; the state of the transmission gate determines whether or not queued frames can be selected for transmission (see Figure 8-12). For a given queue, the transmission gate can be in one of two states:

- a) Open: Queued frames are selected for transmission, in accordance with the definition of the transmission selection algorithm associated with the queue.
- b) Closed: Queued frames are not selected for transmission.

(Source: IEEE Standard for Local and metropolitan area networks— Bridges and Bridged Networks Amendment 25: Enhancements for Scheduled Traffic (IEEE 802.1Qbv-2015))

8.6.8 Transmission selection

For each Port, frames are selected for transmission on the basis of the traffic classes that the Port supports and the operation of the transmission selection algorithms supported by the corresponding queues on that Port. For a given Port and traffic class, frames are selected from the corresponding queue for transmission if and only if

- a) The operation of the transmission selection algorithm supported by that queue determines that there is a frame available for transmission; and
- b) For each queue corresponding to a numerically higher value of traffic class supported by the Port, the operation of the transmission selection algorithm supported by that queue determines that there is no frame available for transmission.

(Source: IEEE Standard for Local and Metropolitan Area Networks—Bridges and Bridged Networks- IEEE Std 802.1Q™-2018)

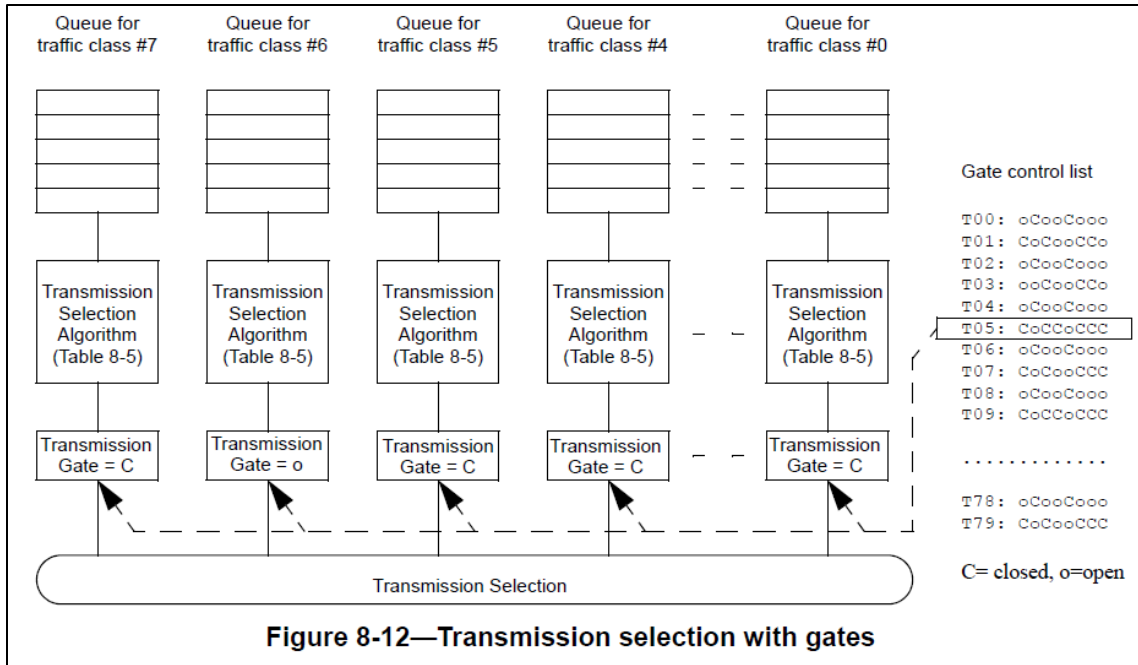

(Source: IEEE Standard for Local and metropolitan area networks— Bridges and Bridged Networks Amendment 25: Enhancements for Scheduled Traffic (IEEE 802.1Qbv-2015))

A gate control list associated with each Port contains an ordered list of gate operations. Each gate operation changes the transmission gate state for the gate associated with each of the Port’s traffic class queues. In an implementation that does not support enhancements for scheduled traffic, all gates are assumed to be permanently in the open state. Table 8-6 identifies the gate operation types, their parameters, and the actions that result from their execution. The state machines that control the execution of the gate control list, along with their variables and procedures, are specified in 8.6.9.

(Source: IEEE Standard for Local and metropolitan area networks— Bridges and Bridged Networks Amendment 25: Enhancements for Scheduled Traffic (IEEE 802.1Qbv-2015))

72. The methods practiced by NEC’s use of the accused products include allowing a device adapter to transmit packets during said time phase uniquely assigned thereto and during said free-access phase. For example, the accused products are used by NEC to implement the IEEE 802.1Q standard. The open gates assigned to the transmission queue of a port (device adapter) transmit the data packets during the transmission time. The transmission selection algorithm determines the transmission time. If the gates are in permanent open state, the data packets are transmitted from the gates during any time. The functionality of assigned time phases

is achieved using open gates transmitting data packets during transmission time. The functionality of free access phase is achieved when the gates are permanently opened for transmission during any time.

8.6.8.4 Enhancements for scheduled traffic

A Bridge or an end station may support enhancements that allow transmission from each queue to be scheduled relative to a known timescale. In order to achieve this, a transmission gate is associated with each queue; the state of the transmission gate determines whether or not queued frames can be selected for transmission (see Figure 8-12). For a given queue, the transmission gate can be in one of two states:

- a) Open: Queued frames are selected for transmission, in accordance with the definition of the transmission selection algorithm associated with the queue.
- b) Closed: Queued frames are not selected for transmission.

(Source: IEEE Standard for Local and metropolitan area networks— Bridges and Bridged Networks Amendment 25: Enhancements for Scheduled Traffic (IEEE 802.1Qbv-2015))

3.4 transmission gate: A gate that connects or disconnects the transmission selection function of the forwarding process from the queue, allowing or preventing it from selecting frames from that queue. The gate has two states, Open and Closed.

(Source: IEEE Standard for Local and metropolitan area networks— Bridges and Bridged Networks Amendment 25: Enhancements for Scheduled Traffic (IEEE 802.1Qbv-2015))

A gate control list associated with each Port contains an ordered list of gate operations. Each gate operation changes the transmission gate state for the gate associated with each of the Port's traffic class queues. In an implementation that does not support enhancements for scheduled traffic, all gates are assumed to be permanently in the open state. Table 8-6 identifies the gate operation types, their parameters, and the actions that result from their execution. The state machines that control the execution of the gate control list, along with their variables and procedures, are specified in 8.6.9.

(Source: IEEE Standard for Local and metropolitan area networks— Bridges and Bridged Networks Amendment 25: Enhancements for Scheduled Traffic (IEEE 802.1Qbv-2015))

73. The methods practiced by NEC's use of the accused products include designating one of said device adapters as a master timing device. For example, the accused products are used by NEC to implement the IEEE 802.1Q standard. The ports of the time aware bridge

(device adapter) uses best master clock algorithm (BMCA) to determine a potential grandmaster port (master timing device).

7.2.2 Time-aware network consisting of a single gPTP domain

Figure 7-1 illustrates an example time-aware network consisting of a single gPTP domain, using all the above network technologies (i.e., (c) - (f) of 7.2.1), where end stations on several local networks are connected to a grandmaster on a backbone network via an EPON access network.

Any PTP Instance with clock sourcing capabilities can be a potential grandmaster, so there is a selection method (the *best master clock algorithm*, or BMCA) that ensures that all of the PTP Instances in a gPTP domain use the same grandmaster.¹² The BMCA is largely identical to that used in IEEE Std 1588-2019,

(Source: <https://1.ieee802.org/wp-content/uploads/2019/03/802-1AS-rev-d8-0.pdf>)

10.3.1.1 Best master clock algorithm overview

In the BMCA (i.e., method (a) of 10.3.1), best master selection information is exchanged between PTP Instances of time-aware systems via Announce messages (see 10.5 and 10.6). Each Announce message contains time-synchronization spanning tree vector information that identifies one PTP Instance as the root of the time-synchronization spanning tree and, if the PTP Instance is grandmaster-capable, the grandmaster. Each PTP Instance in turn uses the information contained in the Announce messages it receives, along with its knowledge of itself, to compute which of the PTP Instances that it has knowledge of ought to be the root of the spanning tree and, if grandmaster-capable, the grandmaster. As part of constructing the time-synchronization spanning tree, each port of each PTP Instance is assigned a port state from Table 10-2 by state machines associated with the ports and with the PTP Instance as a whole.

(Source: <https://1.ieee802.org/wp-content/uploads/2019/03/802-1AS-rev-d8-0.pdf>)

11.1.3 Transport of time-synchronization information

The transport of time-synchronization information by a PTP Instance, using Sync and Follow_Up (or just Sync) messages, is illustrated in Figure 11-2. The mechanism is mathematically equivalent to the mechanism described in IEEE Std 1588-2019 for a peer-to-peer transparent clock that is synchronized (see 11.4.5.1, 11.5.1, and 11.5.2.2 of IEEE Std 1588-2019). However, as will be seen shortly, the processes of transporting synchronization by a peer-to-peer transparent clock that is synchronized and by a boundary clock are mathematically and functionally equivalent. The main functional difference between the two types of clocks is that the boundary clock participates in best master selection and invokes the BMCA, while the peer-to-peer transparent clock does not participate in best master selection and does not invoke the BMCA (and implementations of the two types of clocks can be different).

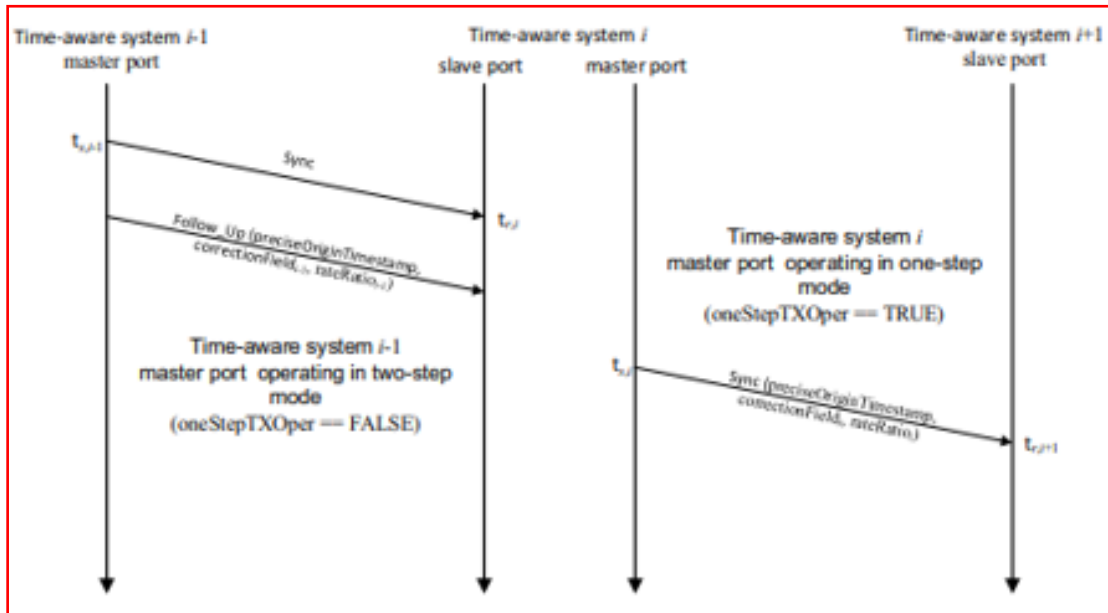

Figure 11-2—Transport of time-synchronization information

(Source: <https://1.ieee802.org/wp-content/uploads/2019/03/802-1AS-rev-d8-0.pdf>)

- c) In gPTP there are only two types of PTP Instances: PTP End Instances and PTP Relay Instances, while IEEE 1588 has ordinary clocks, boundary clocks, end-to-end transparent clocks, and P2P transparent clocks. A PTP End Instance corresponds to an IEEE 1588 ordinary clock, and a PTP Relay Instance is a type of IEEE 1588 boundary clock where its operation is very tightly defined, so much so that a PTP Relay Instance with Ethernet ports can be shown to be mathematically equivalent to a P2P transparent clock in terms of how synchronization is performed, as shown in

(Source: <https://1.ieee802.org/wp-content/uploads/2019/03/802-1AS-rev-d8-0.pdf>)

74. The methods practiced by NEC's use of the accused products include synchronizing the clocks of the remaining device adapters with said master timing device. For

example, the accused products are used by NEC to implement the IEEE 802.1Q standard. The boundary clocks of the slave ports in the time aware bridges (remaining device adapters) are synchronized with the grandmaster boundary clock (master timing device).

c) In gPTP there are only two types of PTP Instances: PTP End Instances and PTP Relay Instances, while IEEE 1588 has ordinary clocks, boundary clocks, end-to-end transparent clocks, and P2P transparent clocks. A PTP End Instance corresponds to an IEEE 1588 ordinary clock, and a PTP Relay Instance is a type of IEEE 1588 boundary clock where its operation is very tightly defined, so much so that a PTP Relay Instance with Ethernet ports can be shown to be mathematically equivalent to a P2P transparent clock in terms of how synchronization is performed, as shown in

(Source: <https://1.ieee802.org/wp-content/uploads/2019/03/802-1AS-rev-d8-0.pdf>)

3.16 PTP End Instance: A PTP Instance that is capable of acting as the source of synchronized time on the network, or destination of synchronized time using the IEEE 802.1AS protocol, or both.

3.17 PTP Instance: A PTP Relay Instance or a PTP End Instance. A PTP Instance implements those portions of this standard indicated as applicable to a PTP Relay Instance or a PTP End Instance. Each PTP Instance operates in exactly one domain.

3.18 PTP Link: Within a domain, a network segment between two PTP Ports using the peer-to-peer delay mechanism of this standard. The peer-to-peer delay mechanism is designed to measure the propagation time over such a link.

NOTE—A PTP Link between PTP Ports of PTP Instances is also a gPTP Communication Path (see 3.9).

3.19 PTP Relay Instance: A PTP Instance that is capable of communicating synchronized time received on one port to other ports, using the IEEE 802.1AS protocol.

NOTE—A PTP Relay Instance could, for example, be contained in a bridge, a router, or a multi-port end station.

(Source: <https://1.ieee802.org/wp-content/uploads/2019/03/802-1AS-rev-d8-0.pdf>)

11.1.3 Transport of time-synchronization information

The transport of time-synchronization information by a PTP Instance, using Sync and Follow_Up (or just Sync) messages, is illustrated in Figure 11-2. The mechanism is mathematically equivalent to the mechanism described in IEEE Std 1588-2019 for a peer-to-peer transparent clock that is synchronized (see 11.4.5.1, 11.5.1, and 11.5.2.2 of IEEE Std 1588-2019). However, as will be seen shortly, the processes of transporting synchronization by a peer-to-peer transparent clock that is synchronized and by a boundary clock are mathematically and functionally equivalent. The main functional difference between the two types of clocks is that the boundary clock participates in best master selection and invokes the BMCA, while the peer-to-peer transparent clock does not participate in best master selection and does not invoke the BMCA (and implementations of the two types of clocks can be different).

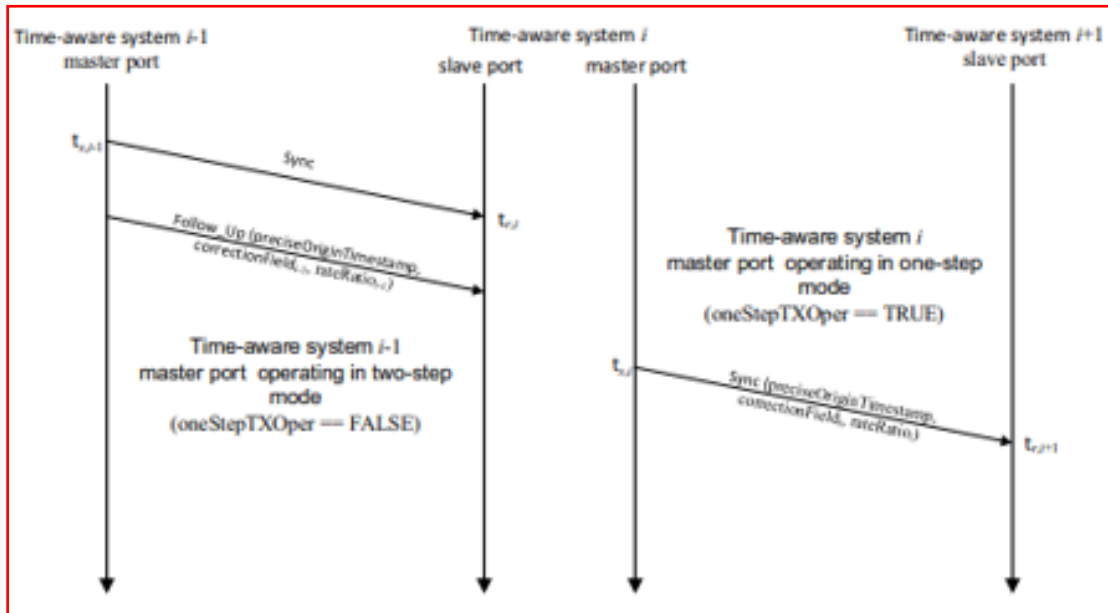

Figure 11-2—Transport of time-synchronization information

(Source: <https://1.ieee802.org/wp-content/uploads/2019/03/802-1AS-rev-d8-0.pdf>)

75. NEC has had knowledge of the ‘702 Patent at least as of March 9, 2007, when the ‘702 Patent was cited by the examiner during the prosecution of U.S. Patent No. 7,391,745, entitled “Multiple access communication system and data transceiver” and assigned to NEC Corporation. The examiner rejected all pending claims in that application as anticipated by the ‘702 Patent. In a June 5, 2007 Amendment and Response, the applicant attempted to distinguish the ‘702 Patent. In an August 3, 2007 Office Action, the examiner maintained his rejection of

the previous claims as anticipated by the '702 Patent and also rejected certain new claims as anticipated by the '702 Patent. The applicant's November 30, 2007 Response describes the '702 Patent as disclosing, among other things, "a specialized Ethernet hub 3a (master station), and a plurality of device adapters 1000 (slave stations)." NEC employee Yukinori Sua, who is listed as inventor on U.S. Patent No. 7,391,745, and others involved in the prosecution of the patent, including at least Donald J. Lecher and Sean M. McGinn, have had knowledge of the '702 Patent at least as of March 9, 2007.

76. Far North Patents has been damaged as a result of the infringing conduct by NEC alleged above. Thus, NEC is liable to Far North Patents in an amount that adequately compensates it for such infringements, which, by law, cannot be less than a reasonable royalty, together with interest and costs as fixed by this Court under 35 U.S.C. § 284.

77. Far North Patents and/or its predecessors-in-interest have satisfied all statutory obligations required to collect pre-filing damages for the full period allowed by law for infringement of the '702 Patent.

COUNT VI

DIRECT INFRINGEMENT OF U.S. PATENT NO. 6,215,797

78. On April 10, 2001, United States Patent No. 6,215,797 ("the '797 Patent") was duly and legally issued by the United States Patent and Trademark Office for an invention entitled "Methods and Apparatus for Providing Quality of Service Guarantees in Computer Networks."

79. Far North Patents is the owner of the '797 Patent, with all substantive rights in and to that patent, including the sole and exclusive right to prosecute this action and enforce the '797 Patent against infringers, and to collect damages for all relevant times.

80. NEC made, had made, used, imported, provided, supplied, distributed, sold, and/or offered for sale products and/or systems including, for example, its NEC QX-S1000, QX-S4100, and QX-S5200 Series PoE+ Gigabit Ethernet Switch families of products that include advanced quality of service capabilities (collectively, “accused products”).



(Source : <https://www.nec-enterprise.com/documents?id=1231&hash=ee65e0bee7d7c9fdc17193aebcca809e2a295fa56a3f8eae7b654c497b1afa1>)

Specifications

Features		S1008GT-2G-PW	S1016GT-4G-PW	S1024GT-4G-PW	
Performance	Switching capacity [bps]	20.0G	40.0G	56.0G	
	Transfer rate [pps]	14.8M	29.7M	41.6M	
	Switching method			S&F	
	MAC address table			8K	
	Routing table (IPv4/IPv6)			-	
	ARP table			32	
Interface	1Gbe	10/100-1000BASE-T	8	16	24
		SFP slot	2	4	4
	Console Port		√	√	√
PoE+	Number of power feedable interfaces	8	16	24	
	Power feeding standard			IEEE802.3af/at	
	Maximum power supply amount per port			30.0W	
	Maximum power supply amount per device	65.0W	124.0W	180.0W	
IRF	IRF stack version			-	
	Maximum number of IRF stacks			-	
	MAD/ISSU			-	
VLAN	IEEE802.1Q			√	
	Port VLAN			√	
	Protocol VLAN			-	
	Voice VLAN			√	
	Max. number of VLAN			4094	
	VLAN mapping			-	
	QinQ			-	

(Source : <https://www.nec-enterprise.com/documents?id=1231&hash=ee65e0bee7d7c9fdc17193aebcca809e2a295fa56a3f8eae7b654c497b1afa1>)

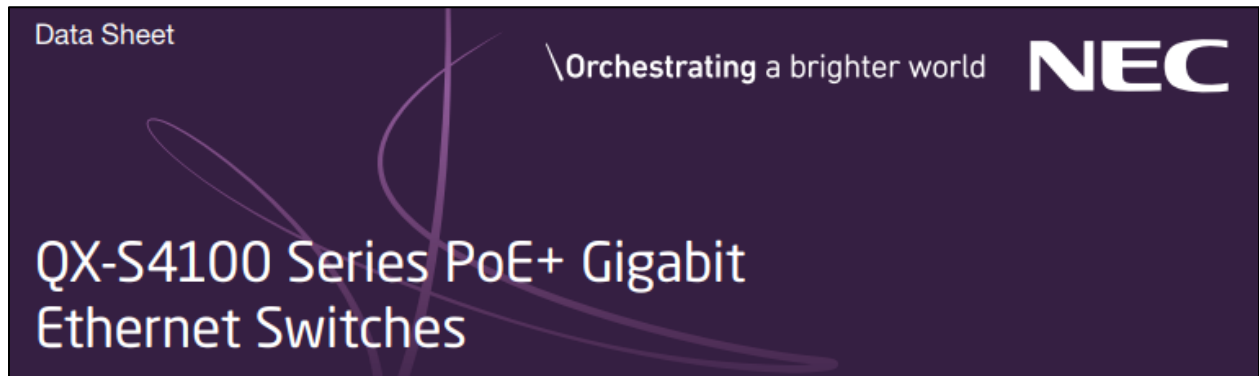

(Source : <https://www.necam.com/docs/?id=d424b393-56d0-44b0-92e1-59e10359ed91>)

Specifications		S4108GT-2G-PW	S4116GT-4G-PW	S4124GT-4G-PW	S4148GT-4G-PW	
Performance	Switching capacity [bps]	20.0G	40.0G	56.0G	104.0G	
	Transfer rate [pps]	14.8M	29.7M	41.6M	77.3M	
	Switching method	S&F				
	MAC address table	16K				
	Routing table (IPv4/IPv6)	64/64				
	ARP table	256				
Interface	1Gbe	10/100-1000BASE-T	8	16	28	48
		SFP slot	2	4	4c	4
	Console Port	✓	✓	✓	✓	
PoE+	Number of power feedable interfaces	8	16	24	48	
	Power feeding standard	IEEE802.3at				
	Maximum power supply amount per port	30.0W				
	Maximum power supply amount per device	125.0W	170.0W	370.0W		
IRF	IRF stack version	IRFv2				
	Maximum number of IRF stacks	4				
	MAD/ISSU	✓ / -				
VLAN	IEEE802.1Q	✓				
	Port VLAN	✓				
	Protocol VLAN	✓				
	Voice VLAN	✓				
	Maximum number of VLAN [number of settable IP addresses]	4094[32]				
	VLAN mapping	✓				

(Source : <https://www.necam.com/docs/?id=d424b393-56d0-44b0-92e1-59e10359ed91>)

S-0301
October 24, 2019

QX-S1000 Ethernet Switch Family

NEC Corporation of America (NEC) offers a diverse range of **commercial-grade** switches:

- QX-S1000 and QX-S4100 product lines for SMB applications
- QX-S5200 product line of access switches for larger, Enterprise applications
- QX-S6600 product line for aggregation in Enterprise networking.

These product lines include non-PoE switches for data applications as well as PoE+ switches that can supply power to SL2100 IP phones, access points and other IoT devices). QX switches can be managed by the SDN Controller, WebGUI management console, or Command Line Interface (CLI).

We are happy to announce that the entire QX family of switches is now available through our Distributor network.

(Source : <http://ntsdirect.com/wp-content/uploads/2019/12/QX-S1000-Ethernet-Switch-Family-1.pdf>)



(Source : https://s3.eu-central-1.amazonaws.com/z3r2zxopa4uuqpw5a4ju/sdnospace/files/pdf/datasheet-NEC-Qx%20S5200%20PoE%2010G%20Switch_eng%202018-v01.pdf)

Specifications			S5224GT-4X-PW	S5248GT-4X-PW
Performance	Switching capacity [bps]		128.0G	176.0G
	Transfer rate [pps]		95.2M	130.9M
	Switching method			S&F
	MAC address table			16K
	Routing table (IPv4/IPv6)			512/256
Interface	ARP table			1K
	10Gbe	SFP slot	-	-
		SFP+ slot	4	4
	40Gbe	QSFP+ slot	-	-
		Console Port	√	√
PoE+	Number of power feedable interfaces		24	48
	Power feeding standard			IEEE802.3at
	Maximum power supply amount per port			30.0W
	Maximum power supply amount per device			370.0W
IRF	IRF stack version			IRFv2
	Maximum number of IRF stacks			6
	MAD/ISSU			√/ -
VLAN	IEEE802.1Q			√
	Port VLAN			√
	Protocol VLAN			√
	Voice VLAN			√
	Max. number of VLAN [number of settable IP addresses]			4094[32]
	VLAN mapping			√
	QinQ			√
	Auto Negotiation/fixed speed and duplex (full/half)			√/√
	Auto MDI • MDIX/ fixed MDIX			√/√
	Flow control (IEEE802.3X)			√
EAP transmitted/BPDU transmitted			√/√	
Port isolate			√	
Packet transfer suppression			B/M/U	

(Source : https://s3.eu-central-1.amazonaws.com/z3r2zxopa4uuqpw5a4ju/sdnospace/files/pdf/datasheet-NEC-Qx%20S5200%20PoE%2010G%20Switch_eng%202018-v01.pdf)

81. By doing so, NEC has directly infringed (literally and/or under the doctrine of equivalents) at least Claim 30 of the '797 Patent. NEC's infringement in this regard is ongoing.

82. NEC has infringed the '797 Patent by using the accused products and thereby practicing a method for regulating traffic in a network including devices for generating packets of data, a network medium for carrying the packets, and a plurality of device adapters connected between the devices and the network medium. For example, the accused products are used by NEC to implement the IEEE 802.1Q standard. IEEE standard 802.1Q (Qbv) implements a method for scheduling traffic in time aware Local Area Network. The time aware network includes multiple end points that transmit data packets and bridges that includes ports (device adapters). The interconnects (network medium) carry the transmitted data packets. The endpoints and bridges are connected via interconnects.

<p>1.1 Project Number: P802.1Qbv 1.2 Type of Document: Standard 1.3 Life Cycle: Full Use</p> <hr/> <p>2.1 Title: Standard for Local and metropolitan area networks--Media Access Control (MAC) Bridges and Virtual Bridged Local Area Networks Amendment: Enhancements for Scheduled Traffic</p> <p>5.2.b. Scope of the project: This amendment specifies time-aware queue-draining procedures, managed objects and extensions to existing protocols that enable bridges and end stations to schedule the transmission of frames based on a synchronized time. Virtual Local Area Network (VLAN) tag encoded priority values are allocated allowing simultaneous support of scheduled traffic, credit-based shaper traffic and other bridged traffic over Local Area Networks (LANs).</p>
--

(Source: <http://www.ieee802.org/1/files/public/docs2014/bv-p802-1Qbv-par-modification-1114.pdf>)

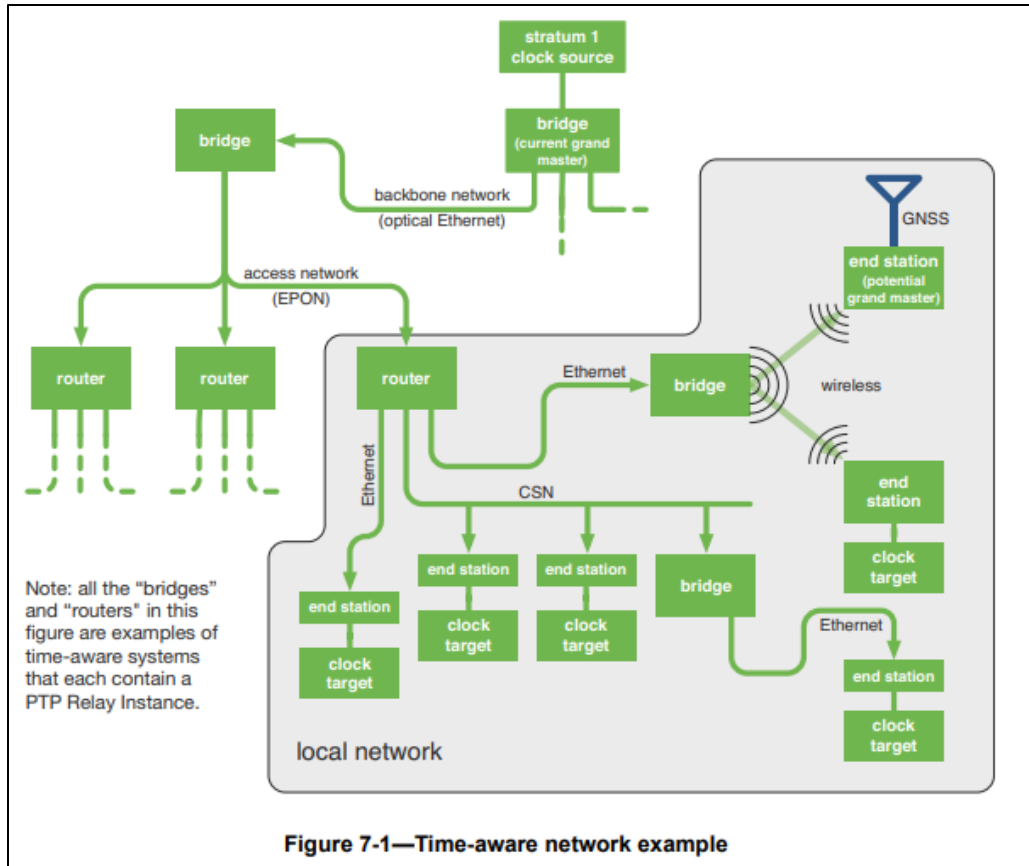

(Source: <https://1.ieee802.org/wp-content/uploads/2019/03/802-1AS-rev-d8-0.pdf>)

7.2 Architecture of a time-aware network

7.2.1 General

A time-aware network consists of a number of interconnected time-aware systems that support the gPTP defined within this standard. These time-aware systems can be any networking device, including, for example, bridges, routers, and end stations. A set of time-aware systems that are interconnected by gPTP-capable network elements is called a gPTP network. Each instance of gPTP that the time-aware systems support is in one gPTP domain, and the instances of gPTP are said to be part of that gPTP domain. A time-aware system can support, and therefore be part of, more than one gPTP domain. The entity of a single time-aware system that executes gPTP in one gPTP domain is called a PTP Instance. A time-aware system can contain multiple PTP Instances, which are each associated with a different gPTP domain. There are two

(Source: <https://1.ieee802.org/wp-content/uploads/2019/03/802-1AS-rev-d8-0.pdf>)

Traffic scheduling

This annex provides some background to the mechanisms provided in this standard for traffic scheduling, with the intent of providing some insight into the motivation for the provision of mechanisms for traffic scheduling and some of the ways that the mechanisms might be used.

Q.1 Motivation

Some applications have a need for frame delivery that is highly predictable in terms of the time at which frame transmission will occur, and the overall latency and jitter that will be experienced as the frame is propagated to its destination. Examples include industrial and automotive control applications, where data transmitted over the network is used to feed the parameters of control loops that are critical to the operation of the plant or machinery involved, and where frames carrying control data are transmitted on a repeating time schedule; late delivery of such frames can result in instability, inaccuracy, or failure of the operation of the control loops concerned. In some implementations, this need has been met by the provision of dedicated, highly engineered networks that are used solely for the transmission of time-critical control traffic; however, as the bandwidth occupied by such traffic is often low, and the cost of providing a dedicated control network can be high, it can be desirable to mix time-critical traffic with other classes of traffic in the same network, as long as such mixing can be achieved while still meeting the timing requirements of the time-critical traffic.

(Source: IEEE Standard for Local and metropolitan area networks— Bridges and Bridged Networks Amendment 25: Enhancements for Scheduled Traffic (IEEE 802.1Qbv-2015))

b) gPTP specifies a media-independent sublayer that simplifies the integration within a single timing domain of multiple different networking technologies with radically different media access protocols. gPTP specifies a media-dependent sublayer for each medium. The information exchanged between PTP Instances has been generalized to support different packet formats and management schemes appropriate to the particular networking technology. IEEE Std 1588-2019, on the other

(Source: <https://1.ieee802.org/wp-content/uploads/2019/03/802-1AS-rev-d8-0.pdf>)

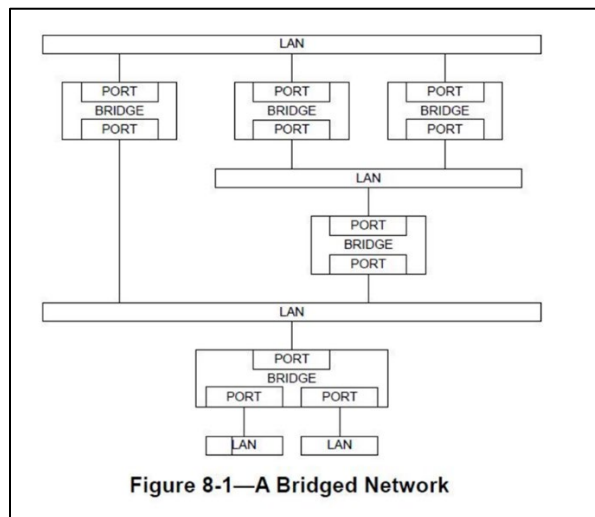

(Source: IEEE Standard for Local and Metropolitan Area Networks—Bridges and Bridged Networks- IEEE Std 802.1Q™-2018)

83. The methods practiced by NEC's use of the accused products include defining a common time reference for the device adapters, said common time reference including a frame of time having a plurality of time phases, each device adapter being uniquely assigned to one of said plurality of time phases, said plurality of time phases including a free-access phase. For example, the accused products are used by NEC to implement the IEEE 802.1Q standard. The time aware bridged LAN uses 802.1AS base time to maintain synchronized time (common time reference) for all the ports in the bridges (device adapters). The bridges containing ports are scheduled for transmission of traffic based on the synchronized time. Each port associated with a specific set of transmission queues includes a plurality of transmission gates. A transmission gate can be in a closed state or open state. The functionality of assigned time phases is achieved using open gates transmitting data packets during transmission time. The functionality of free access phase is achieved when the gates are opened for transmission during any time. IEEE Std. 802.1AS™-2011 is normative and essential to implement an IEEE Std. 802.1Q Compliant System.

1.1 Project Number: P802.1Qbv

1.2 Type of Document: Standard

1.3 Life Cycle: Full Use

2.1 Title: Standard for Local and metropolitan area networks--Media Access Control (MAC) Bridges and Virtual Bridged Local Area Networks Amendment: Enhancements for Scheduled Traffic

5.2.b. Scope of the project: This amendment specifies time-aware queue-draining procedures, managed objects and extensions to existing protocols that enable bridges and end stations to schedule the transmission of frames based on a synchronized time. Virtual Local Area Network (VLAN) tag encoded priority values are allocated allowing simultaneous support of scheduled traffic, credit-based shaper traffic and other bridged traffic over Local Area Networks (LANs).

(Source: <http://www.ieee802.org/1/files/public/docs2014/bv-p802-1Qbv-par-modification-1114.pdf>)

IEEE Std 802.1Q-2018
IEEE Standard for Local and Metropolitan Area Networks—Bridges and Bridged Networks

2. Normative references

The following referenced documents are indispensable for the application of this document (i.e., they must be understood and used, so each referenced document is cited in the text and its relationship to this document is explained). For dated references, only the edition cited applies. For undated references, the latest edition of the referenced document (including any amendments or corrigenda) applies.

ANSI X3.159, American National Standards for Information Systems—Programming Language—C.⁵

IEEE Std 802[®], IEEE Standard for Local and metropolitan area networks: Overview and Architecture.^{6,7}

IEEE Std 802.1AB™, IEEE Standard for Local and metropolitan area networks—Station and Media Access Control Connectivity Discovery.

IEEE Std 802.1AC™, IEEE Standard for Local and metropolitan area networks—Media Access Control (MAC) Service Definition.

IEEE Std 802.1AE™, IEEE Standard for Local and metropolitan area networks—Media Access Control (MAC) Security.

IEEE Std 802.1AS™, IEEE Standard for Local and metropolitan area networks—Timing and Synchronization for Time-Sensitive Applications in Bridged Local Area Networks.

(Source: IEEE Standard for Local and Metropolitan Area Networks—Bridges and Bridged Networks- IEEE Std 802.1Q™-2018)

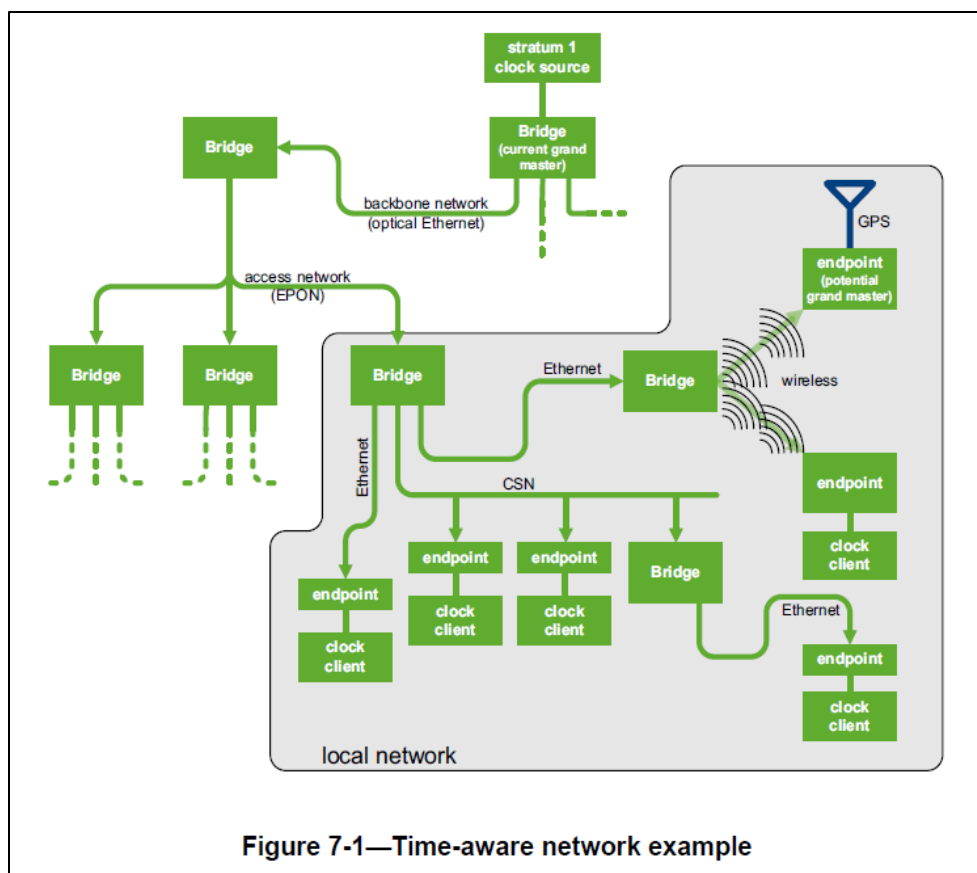

(Source: IEEE Standard for Local and metropolitan area networks - Timing and Synchronization for Time - Sensitive Applications in Bridged Local Area Networks - IEEE Std 802.1AS™-2011)

3.16 PTP End Instance: A PTP Instance that is capable of acting as the source of synchronized time on the network, or destination of synchronized time using the IEEE 802.1AS protocol, or both.

3.17 PTP Instance: A PTP Relay Instance or a PTP End Instance. A PTP Instance implements those portions of this standard indicated as applicable to a PTP Relay Instance or a PTP End Instance. Each PTP Instance operates in exactly one domain.

3.18 PTP Link: Within a domain, a network segment between two PTP Ports using the peer-to-peer delay mechanism of this standard. The peer-to-peer delay mechanism is designed to measure the propagation time over such a link.

NOTE—A PTP Link between PTP Ports of PTP Instances is also a gPTP Communication Path (see 3.9).

3.19 PTP Relay Instance: A PTP Instance that is capable of communicating synchronized time received on one port to other ports, using the IEEE 802.1AS protocol.

NOTE—A PTP Relay Instance could, for example, be contained in a bridge, a router, or a multi-port end station.

(Source: <https://1.ieee802.org/wp-content/uploads/2019/03/802-1AS-rev-d8-0.pdf>)

8.6.8.4 Enhancements for scheduled traffic

A Bridge or an end station may support enhancements that allow transmission from each queue to be scheduled relative to a known timescale. In order to achieve this, a transmission gate is associated with each queue; the state of the transmission gate determines whether or not queued frames can be selected for transmission (see Figure 8-12). For a given queue, the transmission gate can be in one of two states:

- a) Open: Queued frames are selected for transmission, in accordance with the definition of the transmission selection algorithm associated with the queue.
- b) Closed: Queued frames are not selected for transmission.

(Source: IEEE Standard for Local and metropolitan area networks— Bridges and Bridged Networks Amendment 25: Enhancements for Scheduled Traffic (IEEE 802.1Qbv-2015))

8.6.8 Transmission selection

For each Port, frames are selected for transmission on the basis of the traffic classes that the Port supports and the operation of the transmission selection algorithms supported by the corresponding queues on that Port. For a given Port and traffic class, frames are selected from the corresponding queue for transmission if and only if

- a) The operation of the transmission selection algorithm supported by that queue determines that there is a frame available for transmission; and
- b) For each queue corresponding to a numerically higher value of traffic class supported by the Port, the operation of the transmission selection algorithm supported by that queue determines that there is no frame available for transmission.

(Source: IEEE Standard for Local and Metropolitan Area Networks—Bridges and Bridged Networks- IEEE Std 802.1Q™-2018)

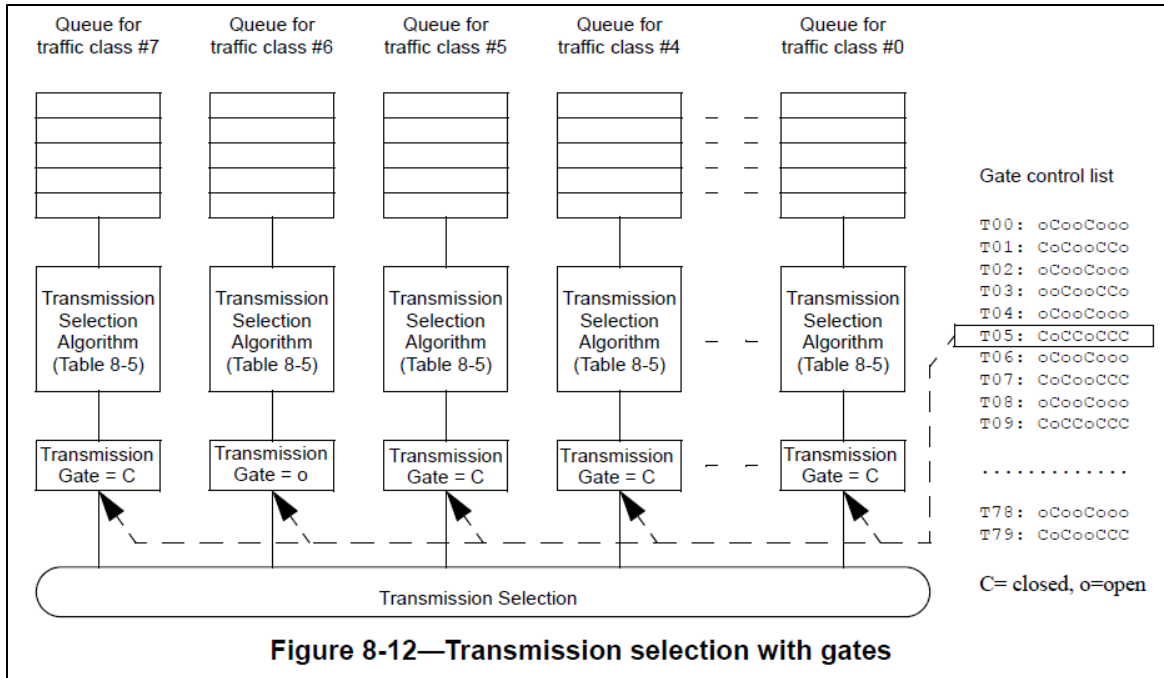

(Source: IEEE Standard for Local and metropolitan area networks— Bridges and Bridged Networks Amendment 25: Enhancements for Scheduled Traffic (IEEE 802.1Qbv-2015))

A gate control list associated with each Port contains an ordered list of gate operations. Each gate operation changes the transmission gate state for the gate associated with each of the Port’s traffic class queues. In an implementation that does not support enhancements for scheduled traffic, all gates are assumed to be permanently in the open state. Table 8-6 identifies the gate operation types, their parameters, and the actions that result from their execution. The state machines that control the execution of the gate control list, along with their variables and procedures, are specified in 8.6.9.

(Source: IEEE Standard for Local and metropolitan area networks— Bridges and Bridged Networks Amendment 25: Enhancements for Scheduled Traffic (IEEE 802.1Qbv-2015))

84. The methods practiced by NEC’s use of the accused products include allowing a device adapter to transmit packets during said time phase uniquely assigned thereto and during said free-access phase. For example, the accused products are used by NEC to implement the IEEE 802.1Q standard. The open gates assigned to the transmission queue of a port (device adapter) transmit the data packets during the transmission time. The transmission selection algorithm determines the transmission time. If the gates are in permanent open state, the data packets are transmitted from the gates during any time. The functionality of assigned time phases

is achieved using open gates transmitting data packets during transmission time. The functionality of free access phase is achieved when the gates are permanently opened for transmission during any time.

8.6.8.4 Enhancements for scheduled traffic

A Bridge or an end station may support enhancements that allow transmission from each queue to be scheduled relative to a known timescale. In order to achieve this, a transmission gate is associated with each queue; the state of the transmission gate determines whether or not queued frames can be selected for transmission (see Figure 8-12). For a given queue, the transmission gate can be in one of two states:

- a) Open: Queued frames are selected for transmission, in accordance with the definition of the transmission selection algorithm associated with the queue.
- b) Closed: Queued frames are not selected for transmission.

(Source: IEEE Standard for Local and metropolitan area networks— Bridges and Bridged Networks Amendment 25: Enhancements for Scheduled Traffic (IEEE 802.1Qbv-2015))

3.4 transmission gate: A gate that connects or disconnects the transmission selection function of the forwarding process from the queue, allowing or preventing it from selecting frames from that queue. The gate has two states, Open and Closed.

(Source: IEEE Standard for Local and metropolitan area networks— Bridges and Bridged Networks Amendment 25: Enhancements for Scheduled Traffic (IEEE 802.1Qbv-2015))

11.1.3 Transport of time-synchronization information

The transport of time-synchronization information by a PTP Instance, using Sync and Follow_Up (or just Sync) messages, is illustrated in Figure 11-2. The mechanism is mathematically equivalent to the mechanism described in IEEE Std 1588-2019 for a peer-to-peer transparent clock that is synchronized (see 11.4.5.1, 11.5.1, and 11.5.2.2 of IEEE Std 1588-2019). However, as will be seen shortly, the processes of transporting synchronization by a peer-to-peer transparent clock that is synchronized and by a boundary clock are mathematically and functionally equivalent. The main functional difference between the two types of clocks is that the boundary clock participates in best master selection and invokes the BMCA, while the peer-to-peer transparent clock does not participate in best master selection and does not invoke the BMCA (and implementations of the two types of clocks can be different).

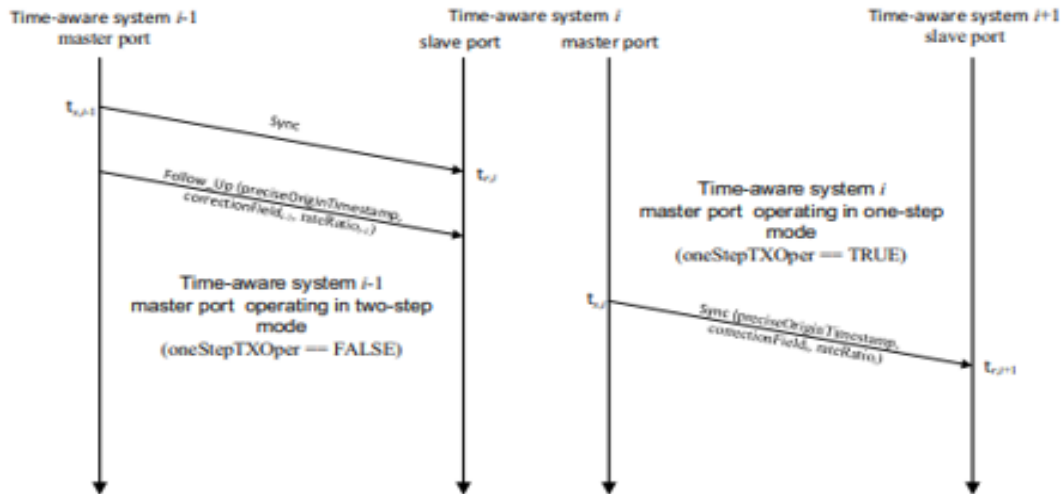

Figure 11-2—Transport of time-synchronization information

(Source: IEEE Standard for Local and metropolitan area networks— Bridges and Bridged Networks Amendment 25: Enhancements for Scheduled Traffic (IEEE 802.1Qbv-2015))

A gate control list associated with each Port contains an ordered list of gate operations. Each gate operation changes the transmission gate state for the gate associated with each of the Port's traffic class queues. In an implementation that does not support enhancements for scheduled traffic, all gates are assumed to be permanently in the open state. Table 8-6 identifies the gate operation types, their parameters, and the actions that result from their execution. The state machines that control the execution of the gate control list, along with their variables and procedures, are specified in 8.6.9.

(Source: IEEE Standard for Local and metropolitan area networks— Bridges and Bridged Networks Amendment 25: Enhancements for Scheduled Traffic (IEEE 802.1Qbv-2015))

85. The methods practiced by NEC's use of the accused products include cyclically repeating said frame. For example, the accused products are used by NEC to implement the

IEEE 802.1Q standard. IEEE Std. 802.1Q-2018 supports cyclic queuing and forwarding structures to create synchronized frames and gates that are repeated periodically (Annex T).

Cyclic queuing and forwarding⁵³

T.1 Overview of CQF

Cyclic queuing and forwarding (CQF) is a method of traffic shaping that can deliver deterministic, and easily calculated, latency for time-sensitive traffic streams. As the name implies, the principle underlying CQF is that stream traffic is transmitted and queued for transmission along a network path in a cyclic manner. Time is divided into numbered time intervals $i, i+1, i+2, \dots, i+N$, each of duration d . Frames transmitted by a Bridge, *Alice*, during time interval i are received by a downstream Bridge, *Bob*, during time interval i and are transmitted onwards by *Bob* towards Bridge *Charlie* during time interval $i+1$, and so on. A starting assumption is that, for a given traffic class, all Bridges and all end stations connected to a given bridge have a common understanding (to a known accuracy) of the start time of cycle i , and the cycle duration, d .

Frames transmitted by *Alice* during interval i are transmitted by *Bob* in interval $i+1$; the maximum possible delay experienced by a given frame is from the beginning of i to the end of $i+1$, or twice d . Similarly, the minimum possible delay experienced is from the end of i to the beginning of $i+1$, which is zero. More generally, the maximum delay experienced by a given frame is

$$(h+1) \times d$$

and the minimum delay experienced by a given frame is

$$(h-1) \times d$$

where h is the number of hops.

(Source: IEEE Standard for Local and Metropolitan Area Networks—Bridges and Bridged Networks- IEEE Std 802.1Q™-2018)

Traffic scheduling

This annex provides some background to the mechanisms provided in this standard for traffic scheduling, with the intent of providing some insight into the motivation for the provision of mechanisms for traffic scheduling and some of the ways that the mechanisms might be used.

Q.1 Motivation

Some applications have a need for frame delivery that is highly predictable in terms of the time at which frame transmission will occur, and the overall latency and jitter that will be experienced as the frame is propagated to its destination. Examples include industrial and automotive control applications, where data transmitted over the network is used to feed the parameters of control loops that are critical to the operation of the plant or machinery involved, and where frames carrying control data are transmitted on a repeating time schedule; late delivery of such frames can result in instability, inaccuracy, or failure of the operation of the control loops concerned. In some implementations, this need has been met by the provision of dedicated, highly engineered networks that are used solely for the transmission of time-critical control traffic; however, as the bandwidth occupied by such traffic is often low, and the cost of providing a dedicated control network can be high, it can be desirable to mix time-critical traffic with other classes of traffic in the same network, as long as such mixing can be achieved while still meeting the timing requirements of the time-critical traffic.

(Source: IEEE Standard for Local and metropolitan area networks— Bridges and Bridged

Networks Amendment 25: Enhancements for Scheduled Traffic (IEEE 802.1Qbv-2015))

86. NEC has had knowledge of the ‘797 Patent at least as of the date when it was notified of the filing of this action.

87. Far North Patents has been damaged as a result of the infringing conduct by NEC alleged above. Thus, NEC is liable to Far North Patents in an amount that adequately compensates it for such infringements, which, by law, cannot be less than a reasonable royalty, together with interest and costs as fixed by this Court under 35 U.S.C. § 284.

88. Far North Patents and/or its predecessors-in-interest have satisfied all statutory obligations required to collect pre-filing damages for the full period allowed by law for infringement of the ‘797 Patent.

COUNT VII

DIRECT INFRINGEMENT OF U.S. PATENT NO. 7,986,770

89. On July 26, 2011, United States Patent No. 7,986,770 (“the ‘770 Patent”) was duly and legally issued by the United States Patent and Trademark Office for an invention entitled “Method and Apparatus for Obtaining Telephone Status Over a Network.”

90. Far North Patents is the owner of the ‘770 Patent, with all substantive rights in and to that patent, including the sole and exclusive right to prosecute this action and enforce the ‘770 Patent against infringers, and to collect damages for all relevant times.

91. NEC made, had made, used, imported, provided, supplied, distributed, sold, and/or offered for sale products and/or systems including, for example, its NEC UNIVERGE SV8100, NEC UNIVERGE SV9100, and NEC SL2100 families of products that include advanced presence information capabilities (collectively, “accused products”).

UNIVERGE SV8100



IP Telephony For Your Business

The UNIVERGE SV8100 Communications Server is the ideal system for Small and Medium Businesses (SMBs) requiring a versatile, feature-rich role-based Unified Communications (UC) solution that is completely scalable to grow together your company to meet the communications needs both now and in the future.

(Source : https://my.nec.com/en_MY/products/iptelephony/univerge/sv8100.html)

UNIVERGE® SV8100

The ultimate in Unified Communications

The UNIVERGE® SV8100 is a unique communication solution for up to 500 extensions. It improves business performance significantly by making an entire workforce more reachable wherever they are based.

Part of the UNIVERGE®360 portfolio, the SV8100 creates '360-degree communication' encompassing fixed, mobile and converged communication such as e-mail, Presence and instant messaging. Executives have real-time access to a full circle view of their business; managers easily communicate with team members and supervisors; sales people have immediate access to the data and resources they need to do their jobs anywhere they are.

In short, it makes Unified Communications a reality.

(Source : https://es.nec.com/es_ES/en/documents/10-076-02_NEC_BR_ENG_Univerge_SV8100.pdf)



(Source : <https://www.nec-enterprise.com/documents?id=184&hash=4989c54687f461d54abc78924731d802254ef35934ce2f644990fd5afea9bac9>)



SMART COLLABORATION
WITHOUT THE COST



The SV9100's InUC utilises WebRTC (Real-Time Communications) providing highly cost-effective video and collaboration working seamlessly within your IT environment.
SV9100 users are able to quickly set up audio and video conferences between two or more PCs or Android devices from anywhere with an internet and VPN or LAN for secure connectivity.

- > **Video conferencing, document & screen sharing** for up to 32 (4x8) SV9100 users
- > **4 Free video conferencing channels** included
- > **Presence** - see the status of your colleagues
- > **Deskphone control** - for slicker call control, speed dials & more
- > **Browser phone** - use your PC's audio rather than a telephone

(Source : <https://www.nec-enterprise.com/documents?id=183&hash=a2d504430887bc170b66f5df8d59fe598f3db0a08521578236f9514715d4309b>)

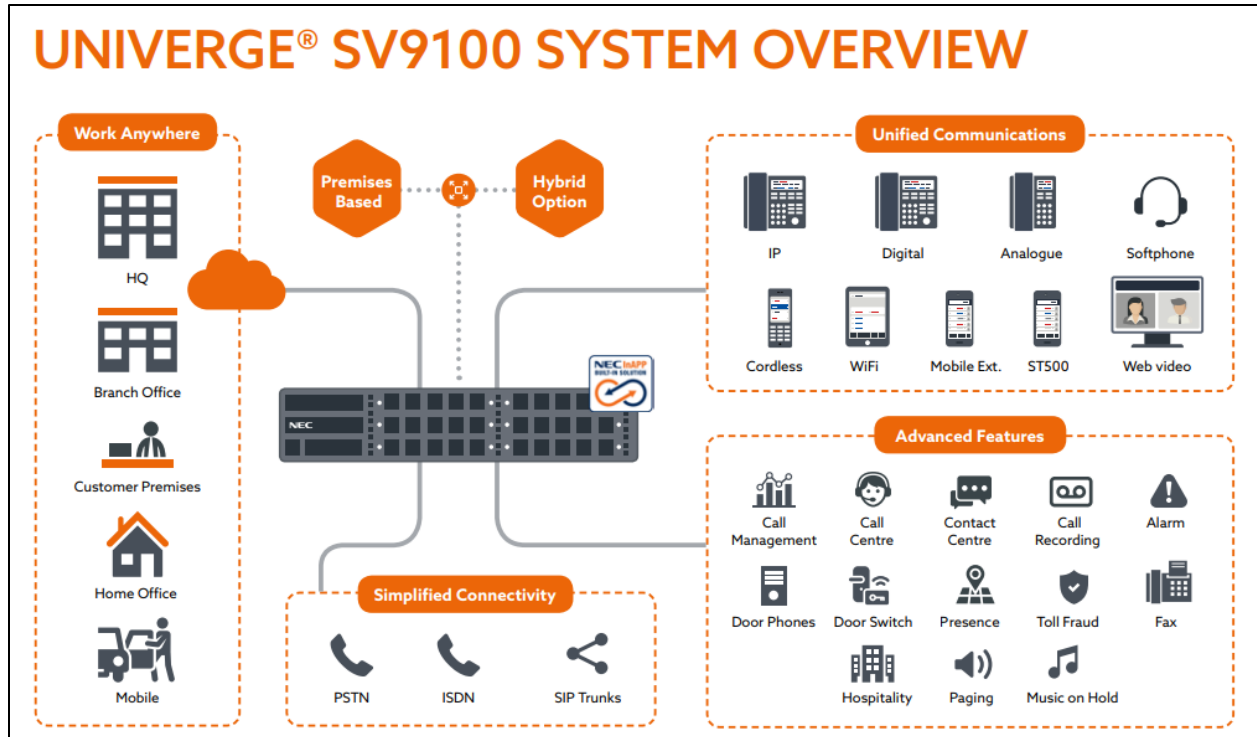

(Source : <https://www.nec-enterprise.com/documents?id=183&hash=a2d504430887bc170b66f5df8d59fe598f3db0a08521578236f9514715d4309b>)

Information sheet

Orchestrating a brighter world **NEC**

Smart communications for
Small Businesses, SoHo and more

SL2100 Communication System

(Source : <https://www.nec-enterprise.com/documents?id=1293&hash=abbed09d1528bc3940f5e6b93fd529e4b03d9f97e8abfb785ca4854be7eb3758>)

With NEC's SL2100, you can ensure that your team stays connected through its wide-range of communication tools that accommodate flexible workspaces and allow free roaming wherever they are.

Work Smarter - Applications to increase efficiency

NEC's SL2100's InUC delivers to you an integrated unified communications (UC) solution that enhances your organization's productivity and collaboration. This productivity-boosting solution offers you key functions that deliver excellent business benefits.

With InUC's intuitive web-based client, it enables full call control from your PC screen. It offers a quick and easy way to manage calls and look up contacts. It also provides video conferencing, collaboration, document sharing, presence and instant messaging which allows you to stay connected and productive from any location.

(Source : https://s3.eu-central-1.amazonaws.com/z3r2zxopa4uuqpw5a4ju/necsl2100/files/us/HW17011_SL2100_Brochure.pdf)

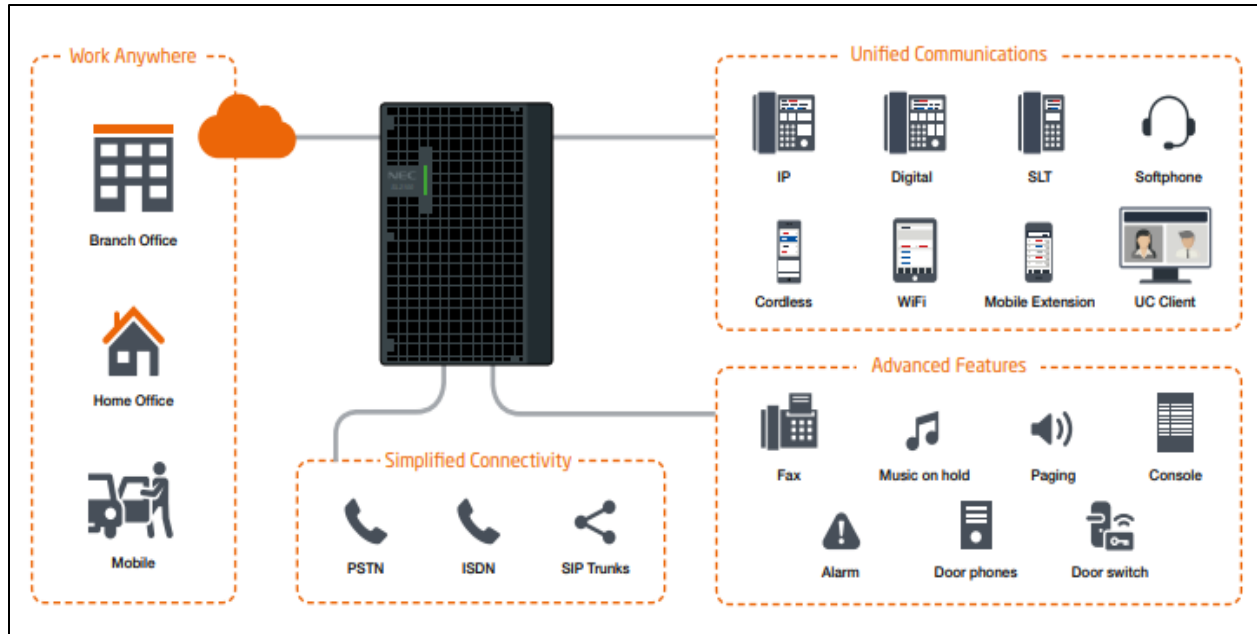

(Source :

https://www.nec.com/en/global/solutions/univerge/support_downloads/pdf/SL2100_Brochure_NEC_UNIVERGE_eng.pdf)

92. By doing so, NEC has directly infringed (literally and/or under the doctrine of equivalents) at least Claim 1 of the ‘770 Patent. NEC’s infringement in this regard is ongoing.

93. NEC has infringed the ‘770 Patent by using the accused products and thereby practicing a method that includes monitoring, by a telephone status monitoring device, a status of a telephone via a first network, wherein the status includes an indication of whether the telephone is engaged in an active telephone call. For example, the accused products provide features like Desktop Suite and DTPlusWare for efficient communication in enterprises. Desktop Suite provides a presence feature in desktops, laptops, mobiles that are associated with softphones. Similarly, DTPlusWare provides a presence feature in desk phones. A cloud-based presence server (telephone status monitoring device) monitors the presence status of all the UC terminals (telephones). A UC terminal is a smart phone associated to internet or a desk phone

associated to intranet. In such instances, the cloud-based presence server monitors the presence status of smartphones, laptops associated with softphone via internet (first network). The presence feature of Desktop Suite and DTPlusWare enables a user to view the presence status of other users. The presence feature of Desktop Suite enables a user to view the presence status of other users. The Desktop Suite provides presence status of a user engaged in an active call through BLF (Busy Lamp Field) field icon. Similarly, DTPlusWare provides the presence status of a user using icons and text (for example: Available).

The image is a screenshot of a promotional document for UNIVERGE® SV8100. It features a white background with blue text. The title "UNIVERGE® SV8100" is in a large, bold, blue font at the top. Below it, the subtitle "The ultimate in Unified Communications" is in a smaller, grey font. The main body of text is in a grey font and describes the product's capabilities, with several lines underlined in red. The text reads: "The UNIVERGE® SV8100 is a unique communication solution for up to 500 extensions. It improves business performance significantly by making an entire workforce more reachable wherever they are based." Below this, another paragraph states: "Part of the UNIVERGE®360 portfolio, the SV8100 creates '360-degree communication' encompassing fixed, mobile and converged communication such as e-mail, Presence and instant messaging. Executives have real-time access to a full circle view of their business; managers easily communicate with team members and supervisors; sales people have immediate access to the data and resources they need to do their jobs anywhere they are." The final line of text in the box says: "In short, it makes Unified Communications a reality."

(Source: https://es.nec.com/es_ES/en/documents/10-076-02_NEC_BR_ENG_Univerge_SV8100.pdf)

<u>UNIVERGE SV8100 Feature Name</u>
Directed Call Pickup
Directory Dialing
Distinctive Ringing, Tones and Flash Patterns
Do Not Disturb
Door Box
Drop Key
<i>D^{term}</i> Cordless II Terminal
<i>D^{term}</i> Cordless Lite II Terminal
<u>DTPlusWare</u>
SV8100/SV8300 Terminals

(Source: [https://www.ttmol.com/downloads/nec-cheat-sheets/SV8100/SV8100%20Features%20and%20Specifications%20Manual%20\(14.6%20MB\).pdf](https://www.ttmol.com/downloads/nec-cheat-sheets/SV8100/SV8100%20Features%20and%20Specifications%20Manual%20(14.6%20MB).pdf))

<u>UNIVERGE SV8100 Feature Name</u>
Handsfree Answerback/Forced Intercom Ringing
Headset Operation
Hold
Hot Key-Pad
Hotel/Motel
Hotline
Howler Tone Service
Intercom
SV8100 PoE Gigabit Switch
<i>Not Supported</i>
IP Multiline Station (SIP)
IP Multiline Station (SIP)
IP Multiline Station (SIP) – ML440 Cordless
IP Single Line Telephone (SIP)
IP Trunk – (SIP) Session Initiation Protocol
IP Trunk – H.323
IP Trunk – (SIP) Session Initiation Protocol
<u>SV8100 UC Desktop Suite Applications</u>
SV8100 UC Desktop Suite Applications

(Source: [https://www.ttmol.com/downloads/nec-cheat-sheets/SV8100/SV8100%20Features%20and%20Specifications%20Manual%20\(14.6%20MB\).pdf](https://www.ttmol.com/downloads/nec-cheat-sheets/SV8100/SV8100%20Features%20and%20Specifications%20Manual%20(14.6%20MB).pdf))

With the UC Desktop Suite, your employees become more mobile and productive. It offers advanced UC applications such as presence, desktop client, softphone, quick messaging, instant messaging (IM), white boarding, and application sharing that enable your workers to collaborate and provide customers the attention they deserve in today's increasingly mobile world. It also seamlessly integrates with both NEC's UNIVERGE SV8100 Automatic Call Distribution

(Source: https://cdn2.hubspot.net/hub/219364/file-302961996-pdf/documents/Brochures/UC_Desktop_Suite.pdf)

UC Desktop Suite Mobile Presence and UC Web Client – Offers you two ways to stay connected and productive from any location. Mobile Presence enables you, through your mobile phone or laptop web-browser, to access and change your status, search for contacts by name and view their presence status or simply click to place a call. UC Web Client can be launched from any web-browser and provides you with access to most all of the features within UC Desktop Suite.

(Source: <https://content.consta.link/wp-content/uploads/SV8100Brochure.pdf>)

Enhanced Presence for Real-Time Status and Availability of Colleagues

DTPlusWare enables users to determine the real-time status and availability of their colleagues instantly. With just a quick glance of your contacts, you can determine if someone is available or if they are away from their desk or out of the office. By eliminating phone tag and call-backs, presence improves employee collaboration which results in increased productivity and efficiency.

You can easily set and/or change your status by simply touching the presence icon on the main menu screen – the presence status screen appears and you just choose the appropriate status from the list.

(Source: <https://www.necam.com/docs/?id=0c154583-ea5d-4add-b92f-432a195455bf>)

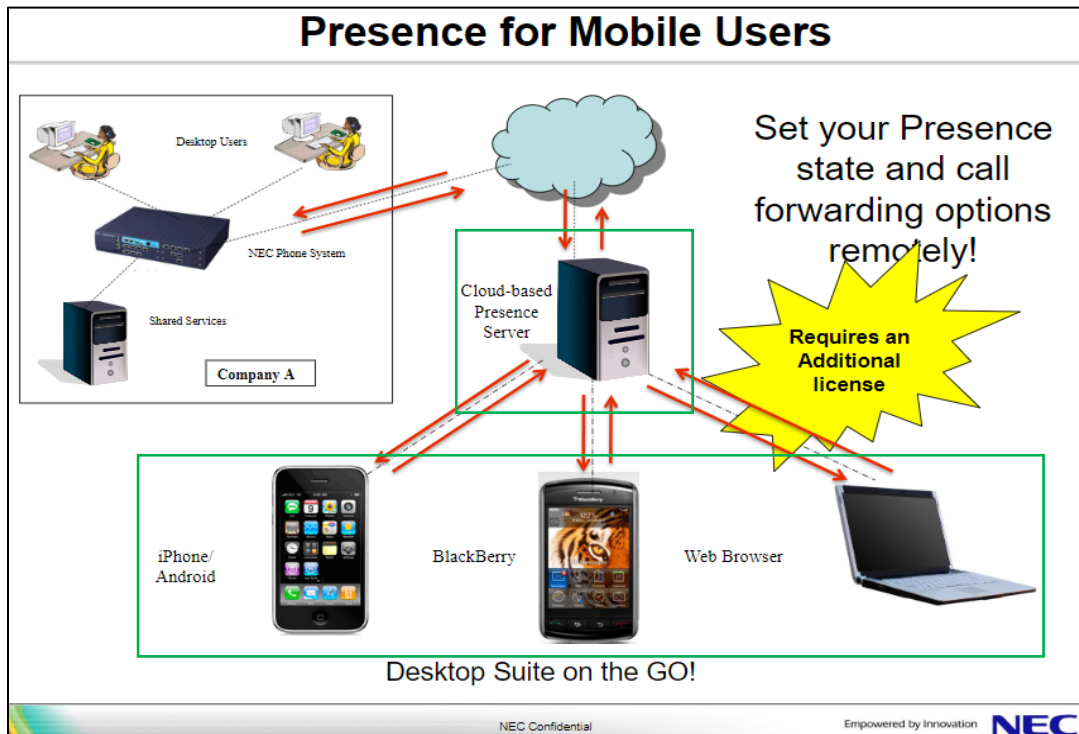

(Source: <https://studylib.net/doc/5423603/nec-sv8100-desktop-suite---phone-systems-plus--inc>)

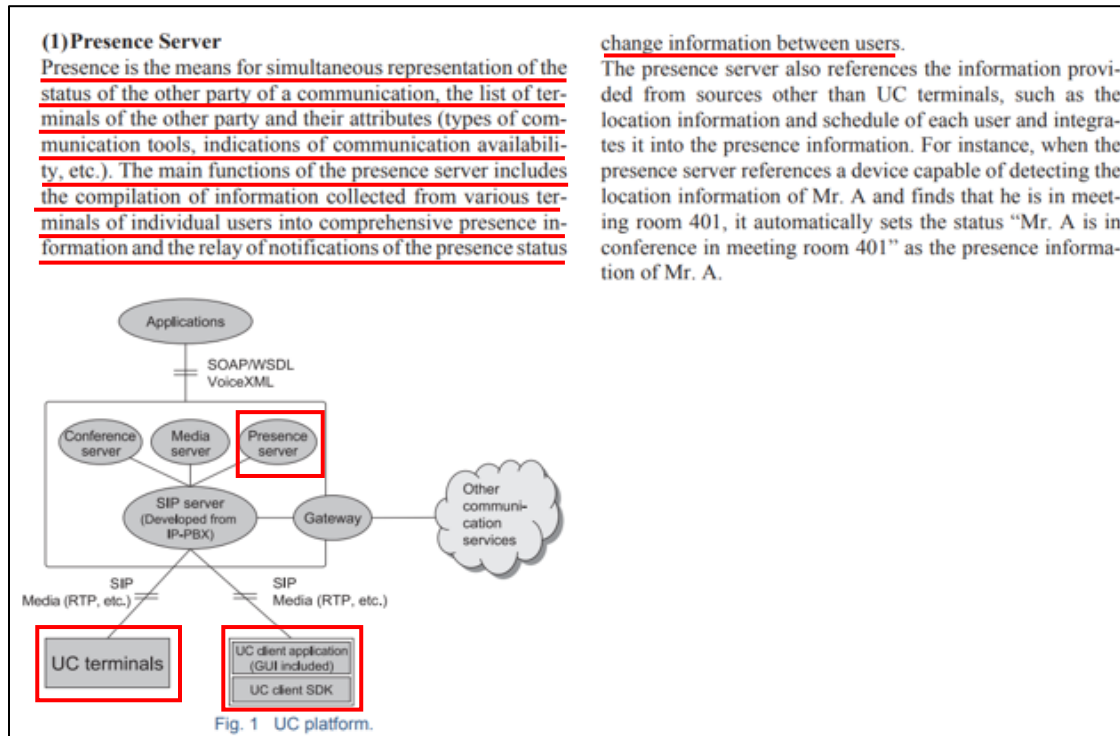

(Source: <https://www.nec.com/en/global/techrep/journal/g08/n03/pdf/080310.pdf>)

Enhanced Presence for Real-Time Status and Availability of Colleagues

UC Desktop Client enables users to determine the real-time status and availability of their colleagues instantly. By eliminating phone tag and call-backs, presence improves employee collaboration which results in increased productivity and efficiency.

You can easily set and/or change your status by simply clicking on the presence icon in the toolbar – the drop-down menu appears and you just click on the appropriate status. With UC Desktop Client's integration with Microsoft Office Outlook, presence status changes can be scheduled to occur automatically by following the Outlook calendar schedule, resulting in automated and synchronized status changes.

Another useful feature is the View Presence Events option on the presence drop-down menu. When this option is elected, a table appears that lists all of the future scheduled presence events.

Enhanced Presence and icons for real-time status and availability of colleagues

(Source: https://cdn2.hubspot.net/hub/219364/file-302961996-pdf/documents/Brochures/UC_Desktop_Suite.pdf)

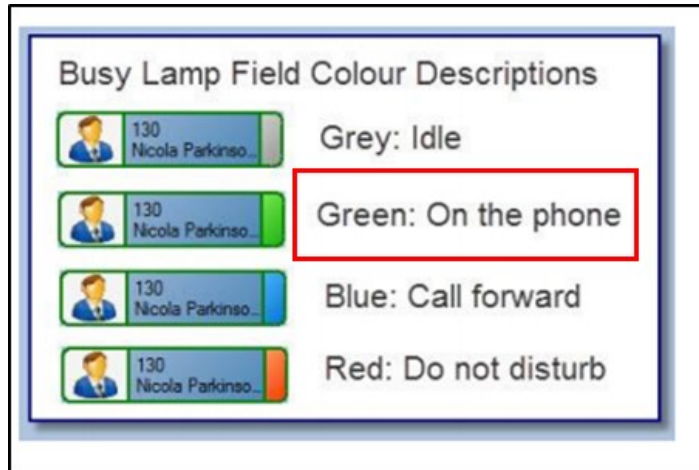

(Source: https://cdn2.hubspot.net/hub/219364/file-302961996-pdf/documents/Brochures/UC_Desktop_Suite.pdf)

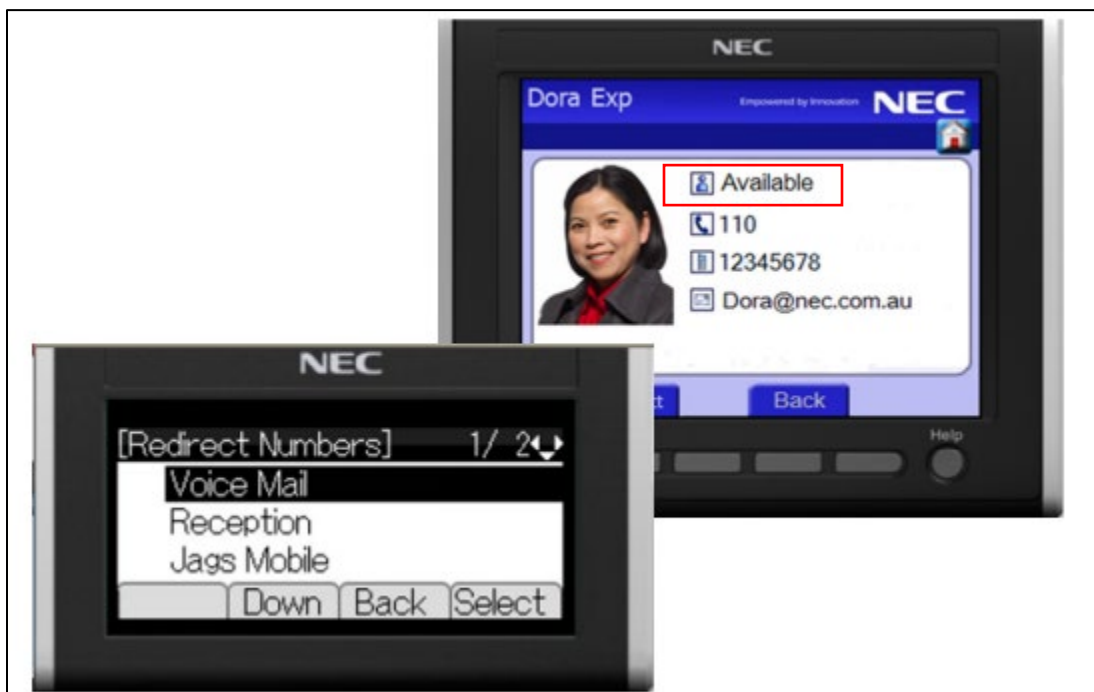

(Source: <https://www.necam.com/docs/?id=0c154583-ea5d-4add-b92f-432a195455bf>)

94. The methods practiced by NEC's use of the accused products include transmitting, by the telephone status monitoring device, the status of the telephone to another device via a second network, wherein the transmitting is in response to the another device attempting to place a call to the telephone, and wherein the first and the second networks are

different networks. For example, a cloud-based presence server (telephone status monitoring device) monitors the presence status of all the terminals (telephones). A terminal can be a smart phone associated to the internet or a desk phone associated to an intranet. Devices like smartphones and laptops are working on an internet network (first network) whereas other devices like desk phones which are present in a company premises are working on an intranet (second network). The presence feature of DTPlusWare enables a user to view the presence status of other users before attempting to place a call. For example, the user of a desk phone (another device) is provided with a presence option and can view the status of called party before placing the call (transmission in response to call attempt from another device).

UC Desktop Suite Mobile Presence and UC Web Client – Offers you two ways to stay connected and productive from any location. Mobile Presence enables you, through your mobile phone or laptop web-browser, to access and change your status, search for contacts by name and view their presence status or simply click to place a call. UC Web Client can be launched from any web-browser and provides you with access to most all of the features within UC Desktop Suite.

(Source: <https://content.consta.link/wp-content/uploads/SV8100Brochure.pdf>)

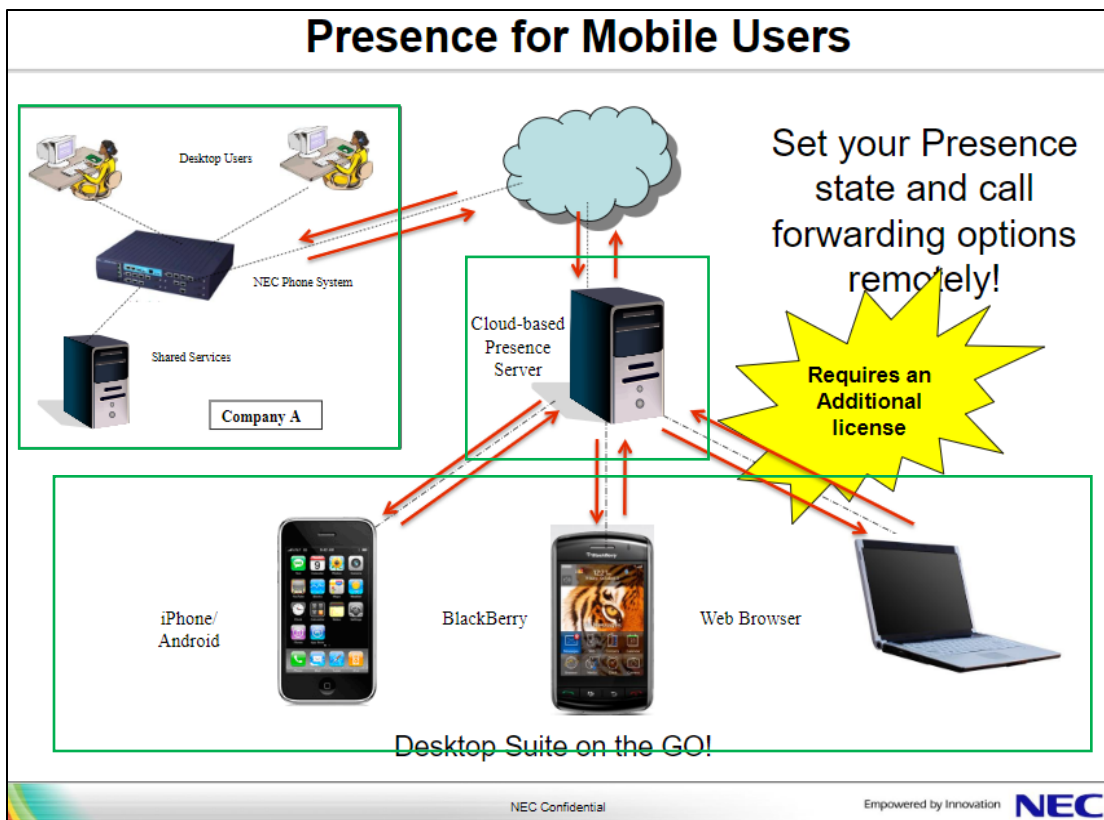

(Source: <https://studylib.net/doc/5423603/nec-sv8100-desktop-suite---phone-systems-plus--inc>)

(1) Presence Server

Presence is the means for simultaneous representation of the status of the other party of a communication, the list of terminals of the other party and their attributes (types of communication tools, indications of communication availability, etc.). The main functions of the presence server includes the compilation of information collected from various terminals of individual users into comprehensive presence information and the relay of notifications of the presence status

change information between users.

The presence server also references the information provided from sources other than UC terminals, such as the location information and schedule of each user and integrates it into the presence information. For instance, when the presence server references a device capable of detecting the location information of Mr. A and finds that he is in meeting room 401, it automatically sets the status "Mr. A is in conference in meeting room 401" as the presence information of Mr. A.

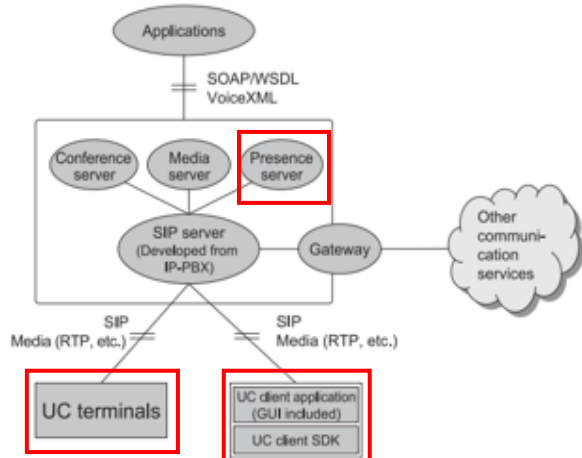



Fig. 1 UC platform.

(Source: <https://www.nec.com/en/global/techrep/journal/g08/n03/pdf/080310.pdf>)



Charlie's Calling →



- ❖ Open contact records based on Caller ID
- ❖ Open forms based on number dialed
- ❖ Display:
 - ❖ Phone status of others
 - ❖ Others Presence
 - ❖ Call Center Information

NEC Confidential
Empowered by Innovation **NEC**

(Source: <https://studylib.net/doc/5423603/nec-sv8100-desktop-suite---phone-systems-plus--inc>)



(Source: <https://www.necam.com/docs/?id=0c154583-ea5d-4add-b92f-432a195455bf>)

95. Far North Patents only asserts method claims from the '770 Patent.

96. NEC has had knowledge of the '770 Patent at least as of the date when it was notified of the filing of this action.

97. Far North Patents has been damaged as a result of the infringing conduct by NEC alleged above. Thus, NEC is liable to Far North Patents in an amount that adequately compensates it for such infringements, which, by law, cannot be less than a reasonable royalty, together with interest and costs as fixed by this Court under 35 U.S.C. § 284.

98. Far North Patents and/or its predecessors-in-interest have satisfied all statutory obligations required to collect pre-filing damages for the full period allowed by law for infringement of the '770 Patent.

COUNT VIII

DIRECT INFRINGEMENT OF U.S. PATENT NO. 7,088,802

99. On August 8, 2006, United States Patent No. 7,088,802 (“the ‘802 Patent”) was duly and legally issued by the United States Patent and Trademark Office for an invention entitled “Method and Apparatus for Obtaining Telephone Status Over a Network.”

100. Far North Patents is the owner of the ‘802 Patent, with all substantive rights in and to that patent, including the sole and exclusive right to prosecute this action and enforce the ‘802 Patent against infringers, and to collect damages for all relevant times.

101. NEC made, had made, used, imported, provided, supplied, distributed, sold, and/or offered for sale products and/or systems including, for example, its NEC UNIVERGE SV8100, NEC UNIVERGE SV9100, and NEC SL2100 families of products that include advanced presence information capabilities (collectively, “accused products”):

UNIVERGE SV8100



IP Telephony For Your Business

The UNIVERGE SV8100 Communications Server is the ideal system for Small and Medium Businesses (SMBs) requiring a versatile, feature-rich role-based Unified Communications (UC) solution that is completely scalable to grow together your company to meet the communications needs both now and in the future.

(Source : https://my.nec.com/en_MY/products/iptelephony/univerge/sv8100.html)

UNIVERGE® SV8100

The ultimate in Unified Communications

The UNIVERGE® SV8100 is a unique communication solution for up to 500 extensions. It improves business performance significantly by making an entire workforce more reachable wherever they are based.

Part of the UNIVERGE®360 portfolio, the SV8100 creates '360-degree communication' encompassing fixed, mobile and converged communication such as e-mail, Presence and instant messaging. Executives have real-time access to a full circle view of their business; managers easily communicate with team members and supervisors; sales people have immediate access to the data and resources they need to do their jobs anywhere they are.

In short, it makes Unified Communications a reality.

(Source : https://es.nec.com/es_ES/en/documents/10-076-02_NEC_BR_ENG_Univerge_SV8100.pdf)



(Source : <https://www.nec-enterprise.com/documents?id=184&hash=4989c54687f461d54abc78924731d802254ef35934ce2f644990fd5afea9bac9>)



SMART COLLABORATION
WITHOUT THE COST



The SV9100's InUC utilises WebRTC (Real-Time Communications) providing highly cost-effective video and collaboration working seamlessly within your IT environment.
SV9100 users are able to quickly set up audio and video conferences between two or more PCs or Android devices from anywhere with an internet and VPN or LAN for secure connectivity.

- > **Video conferencing, document & screen sharing** for up to 32 (4x8) SV9100 users
- > **4 Free video conferencing channels** included
- > **Presence** - see the status of your colleagues
- > **Deskphone control** - for slicker call control, speed dials & more
- > **Browser phone** - use your PC's audio rather than a telephone

(Source : <https://www.nec-enterprise.com/documents?id=183&hash=a2d504430887bc170b66f5df8d59fe598f3db0a08521578236f9514715d4309b>)

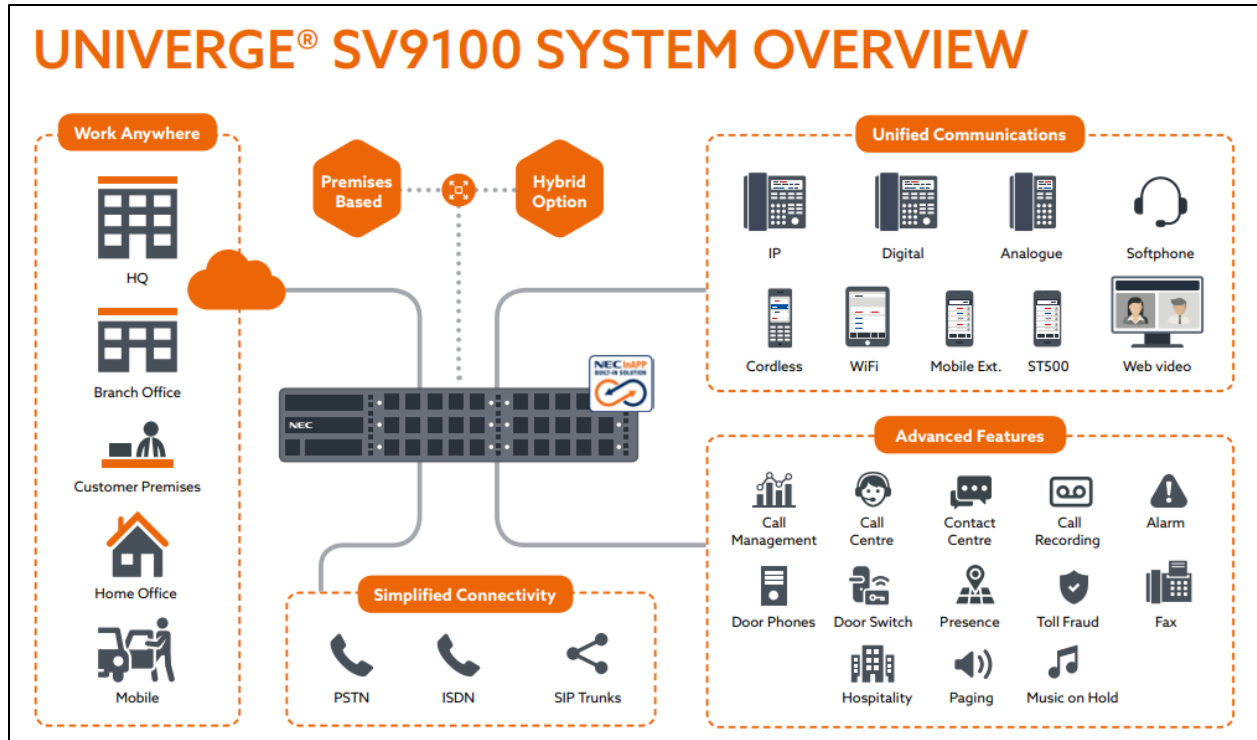

(Source : <https://www.nec-enterprise.com/documents?id=183&hash=a2d504430887bc170b66f5df8d59fe598f3db0a08521578236f9514715d4309b>)

Information sheet

Orchestrating a brighter world **NEC**

Smart communications for
Small Businesses, SoHo and more

SL2100 Communication System

(Source : <https://www.nec-enterprise.com/documents?id=1293&hash=abbed09d1528bc3940f5e6b93fd529e4b03d9f97e8abfb785ca4854be7eb3758>)

With NEC's SL2100, you can ensure that your team stays connected through its wide-range of communication tools that accommodate flexible workspaces and allow free roaming wherever they are.

Work Smarter - Applications to increase efficiency

NEC's SL2100's InUC delivers to you an integrated unified communications (UC) solution that enhances your organization's productivity and collaboration. This productivity-boosting solution offers you key functions that deliver excellent business benefits.

With InUC's intuitive web-based client, it enables full call control from your PC screen. It offers a quick and easy way to manage calls and look up contacts. It also provides video conferencing, collaboration, document sharing, presence and instant messaging which allows you to stay connected and productive from any location.

(Source : https://s3.eu-central-1.amazonaws.com/z3r2zxopa4uuqpw5a4ju/necsl2100/files/us/HW17011_SL2100_Brochure.pdf)

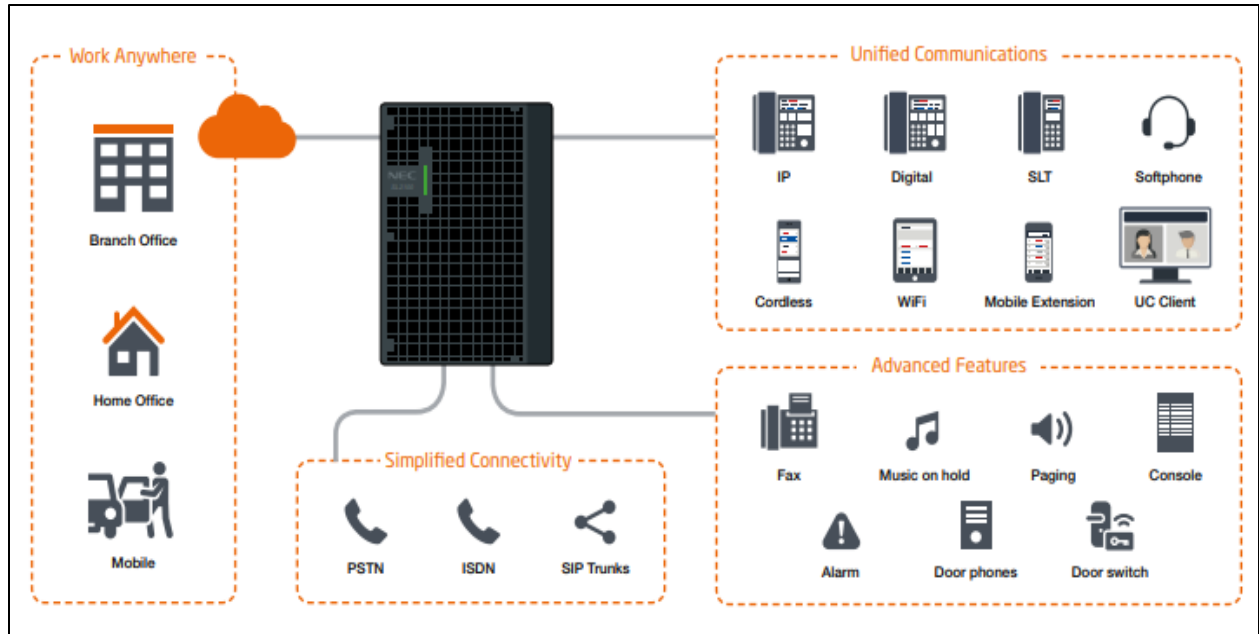

(Source :

https://www.nec.com/en/global/solutions/univerge/support_downloads/pdf/SL2100_Brochure_NEC_UNIVERGE_eng.pdf)

102. By doing so, NEC has directly infringed (literally and/or under the doctrine of equivalents) at least Claim 5 of the '802 Patent. NEC's infringement in this regard is ongoing.

103. NEC has infringed the '802 Patent by using the accused products and thereby practicing a process for determining wireless telecommunication device status including accessing a wireless telecommunication device status file associated with a called party over a network and monitoring the status of the called party's wireless telecommunication device and providing that device status to the device status file. For example, the accused products provide a unified communications (UC) solution with features like Desktop Suite and DTPlusWare for efficient communication in enterprises. Desktop Suite provides presence feature in desktops, laptops, mobiles that are associated with softphones. Similarly, DTPlusWare provides a presence feature in desk phones etc. A cloud-based presence server monitors the presence status of all the

associated terminals. The terminals can be smartphones or soft phones associated with laptops or tablets (wireless telecommunications device). When a call is placed from a desk phone to a laptop associated with softphone the cloud-based presence server associated with the laptop (called party's wireless telecommunication device) monitors and accesses the presence status (device status) and is stored in the server (device status file).

The image is a promotional graphic for the UNIVERGE® SV8100. It features the product name in large blue letters at the top, followed by the tagline 'The ultimate in Unified Communications'. Below this, there are two paragraphs of text, each with a red underline. The first paragraph states that the device is a unique communication solution for up to 500 extensions, improving business performance by making the workforce more reachable. The second paragraph describes it as part of the UNIVERGE®360 portfolio, creating '360-degree communication' encompassing fixed, mobile, and converged communication, such as e-mail, presence, and instant messaging. It highlights real-time access to business data and resources for executives, managers, and salespeople. The final line states that it makes Unified Communications a reality.

UNIVERGE® SV8100
The ultimate in Unified Communications

The UNIVERGE® SV8100 is a unique communication solution for up to 500 extensions. It improves business performance significantly by making an entire workforce more reachable wherever they are based.

Part of the UNIVERGE®360 portfolio, the SV8100 creates '360-degree communication' encompassing fixed, mobile and converged communication such as e-mail, Presence and instant messaging. Executives have real-time access to a full circle view of their business; managers easily communicate with team members and supervisors; sales people have immediate access to the data and resources they need to do their jobs anywhere they are.

In short, it makes Unified Communications a reality.

(Source: https://es.nec.com/es_ES/en/documents/10-076-02_NEC_BR_ENG_Univerge_SV8100.pdf)

<u>UNIVERGE SV8100 Feature Name</u>
Directed Call Pickup
Directory Dialing
Distinctive Ringing, Tones and Flash Patterns
Do Not Disturb
Door Box
Drop Key
<i>D^{term}</i> Cordless II Terminal
<i>D^{term}</i> Cordless Lite II Terminal
<u>DTPlusWare</u>
SV8100/SV8300 Terminals

(Source: [https://www.ttmol.com/downloads/nec-cheat-sheets/SV8100/SV8100%20Features%20and%20Specifications%20Manual%20\(14.6%20MB\).pdf](https://www.ttmol.com/downloads/nec-cheat-sheets/SV8100/SV8100%20Features%20and%20Specifications%20Manual%20(14.6%20MB).pdf))

<u>UNIVERGE SV8100 Feature Name</u>
Handsfree Answerback/Forced Intercom Ringing
Headset Operation
Hold
Hot Key-Pad
Hotel/Motel
Hotline
Howler Tone Service
Intercom
SV8100 PoE Gigabit Switch
<i>Not Supported</i>
IP Multiline Station (SIP)
IP Multiline Station (SIP)
IP Multiline Station (SIP) – ML440 Cordless
IP Single Line Telephone (SIP)
IP Trunk – (SIP) Session Initiation Protocol
IP Trunk – H.323
IP Trunk – (SIP) Session Initiation Protocol
<u>SV8100 UC Desktop Suite Applications</u>
SV8100 UC Desktop Suite Applications

(Source: [https://www.ttmol.com/downloads/nec-cheat-sheets/SV8100/SV8100%20Features%20and%20Specifications%20Manual%20\(14.6%20MB\).pdf](https://www.ttmol.com/downloads/nec-cheat-sheets/SV8100/SV8100%20Features%20and%20Specifications%20Manual%20(14.6%20MB).pdf))

With the UC Desktop Suite, your employees become more mobile and productive. It offers advanced UC applications such as presence, desktop client, softphone, quick messaging, instant messaging (IM), white boarding, and application sharing that enable your workers to collaborate and provide customers the attention they deserve in today's increasingly mobile world. It also seamlessly integrates with both NEC's UNIVERGE SV8100 Automatic Call Distribution

(Source: https://cdn2.hubspot.net/hub/219364/file-302961996-pdf/documents/Brochures/UC_Desktop_Suite.pdf)

UC Desktop Suite Mobile Presence and UC Web Client – Offers you two ways to stay connected and productive from any location. Mobile Presence enables you, through your mobile phone or laptop web-browser, to access and change your status, search for contacts by name and view their presence status or simply click to place a call. UC Web Client can be launched from any web-browser and provides you with access to most all of the features within UC Desktop Suite.

(Source: <https://content.consta.link/wp-content/uploads/SV8100Brochure.pdf>)

Enhanced Presence for Real-Time Status and Availability of Colleagues

DTPlusWare enables users to determine the real-time status and availability of their colleagues instantly. With just a quick glance of your contacts, you can determine if someone is available or if they are away from their desk or out of the office. By eliminating phone tag and call-backs, presence improves employee collaboration which results in increased productivity and efficiency.

You can easily set and/or change your status by simply touching the presence icon on the main menu screen – the presence status screen appears and you just choose the appropriate status from the list.

(Source: <https://www.necam.com/docs/?id=0c154583-ea5d-4add-b92f-432a195455bf>)

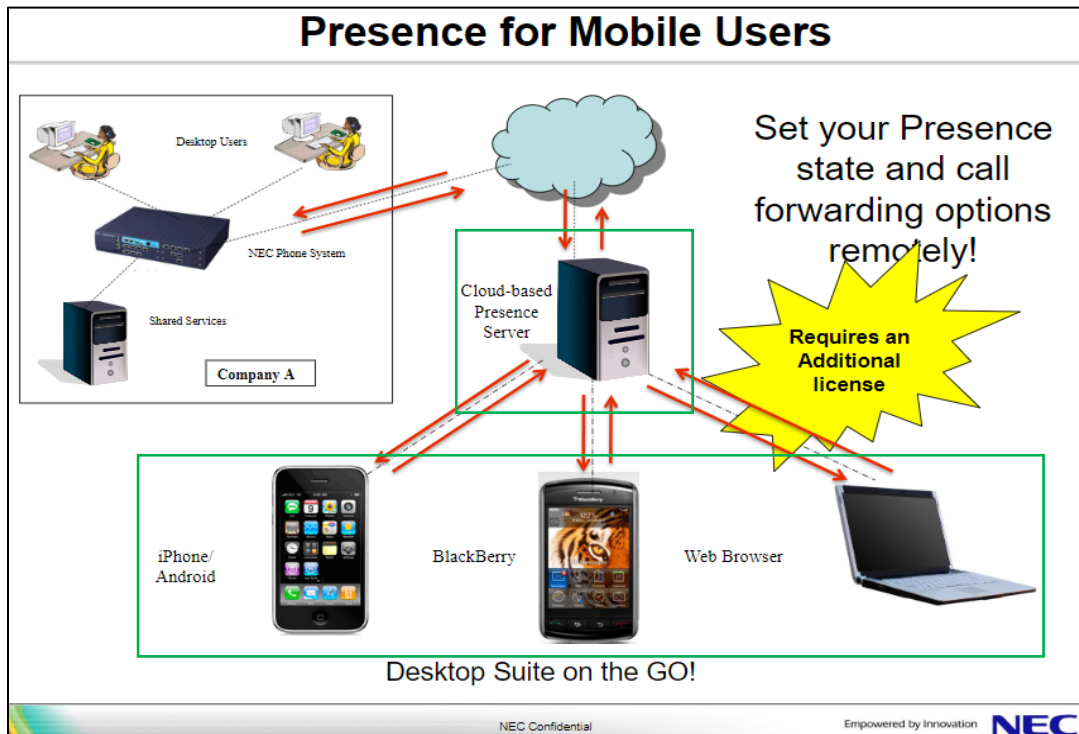

(Source: <https://studylib.net/doc/5423603/nec-sv8100-desktop-suite---phone-systems-plus--inc>)

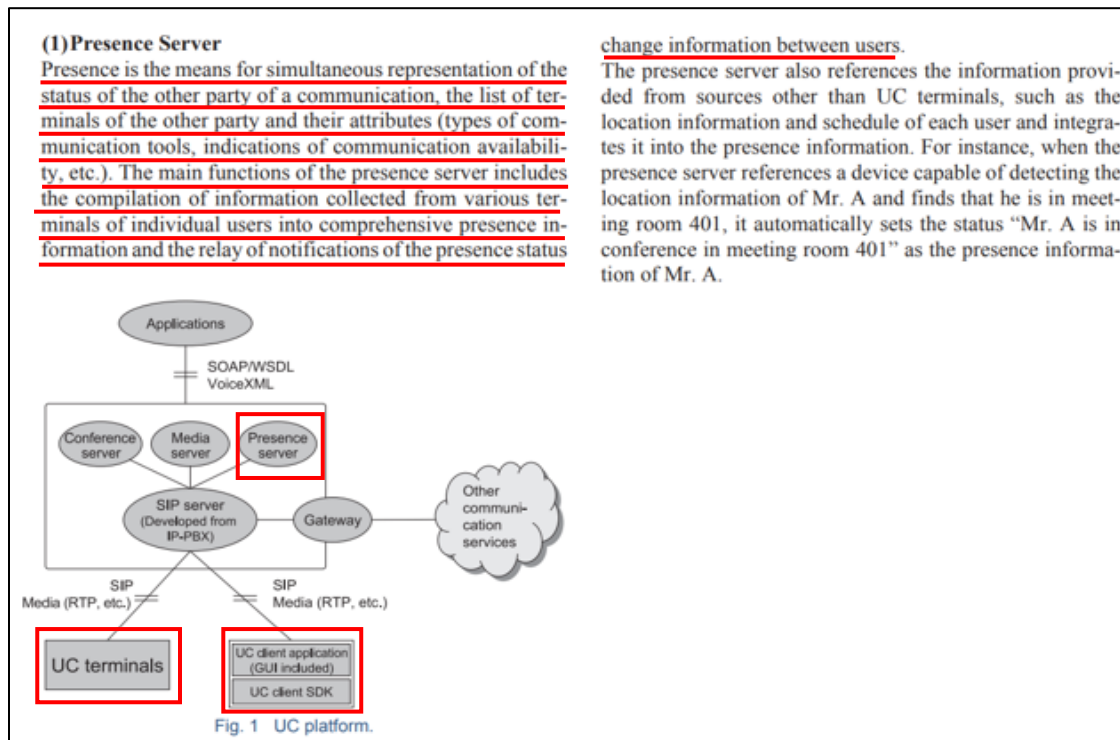

(Source: <https://www.nec.com/en/global/techrep/journal/g08/n03/pdf/080310.pdf>)

104. The processes practiced by NEC’s use of the accused products include sending a calling party a status message comprising the status of the called party's wireless telecommunication device, wherein the status message is sent via a pager. For example, when a call is placed from the desk phone (calling party) to the laptop associated with softphone (called party’s wireless telecommunication device), the desk phone user can use the “presence” feature to receive and view the status message. The status message is displayed on the screen.

UC Desktop Suite Mobile Presence and UC Web Client – Offers you two ways to stay connected and productive from any location. Mobile Presence enables you, through your mobile phone or laptop web-browser, to access and change your status, search for contacts by name and view their presence status or simply click to place a call. UC Web Client can be launched from any web-browser and provides you with access to most all of the features within UC Desktop Suite.

(Source: <https://content.consta.link/wp-content/uploads/SV8100Brochure.pdf>)

Enhanced Presence for Real-Time Status and Availability of Colleagues

DTPlusWare enables users to determine the real-time status and availability of their colleagues instantly. With just a quick glance of your contacts, you can determine if someone is available or if they are away from their desk or out of the office. By eliminating phone tag and call-backs, presence improves employee collaboration which results in increased productivity and efficiency.

You can easily set and/or change your status by simply touching the presence icon on the main menu screen – the presence status screen appears and you just choose the appropriate status from the list.

(Source: <https://www.necam.com/docs/?id=0c154583-ea5d-4add-b92f-432a195455bf>)

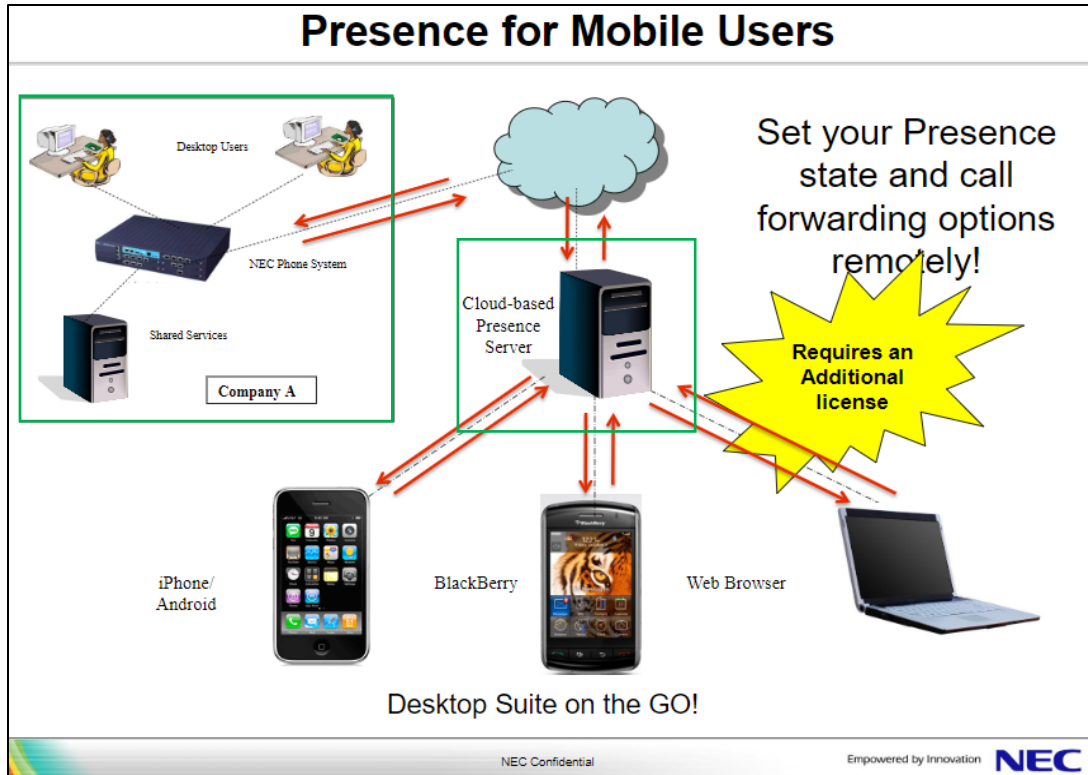

(Source: <https://studylib.net/doc/5423603/nec-sv8100-desktop-suite---phone-systems-plus--inc>)

(1) Presence Server

Presence is the means for simultaneous representation of the status of the other party of a communication, the list of terminals of the other party and their attributes (types of communication tools, indications of communication availability, etc.). The main functions of the presence server includes the compilation of information collected from various terminals of individual users into comprehensive presence information and the relay of notifications of the presence status

change information between users.

The presence server also references the information provided from sources other than UC terminals, such as the location information and schedule of each user and integrates it into the presence information. For instance, when the presence server references a device capable of detecting the location information of Mr. A and finds that he is in meeting room 401, it automatically sets the status “Mr. A is in conference in meeting room 401” as the presence information of Mr. A.

Fig. 1 UC platform.

(Source: <https://www.nec.com/en/global/techrep/journal/g08/n03/pdf/080310.pdf>)

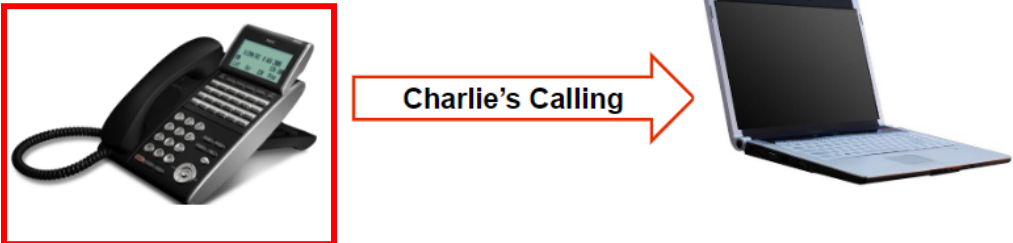

Charlie's Calling

- ❖ Open contact records based on Caller ID
- ❖ Open forms based on number dialed
- ❖ Display:
 - ❖ Phone status of others
 - ❖ Others Presence
 - ❖ Call Center Information

NEC Confidential Empowered by Innovation **NEC**

(Source: <https://studylib.net/doc/5423603/nec-sv8100-desktop-suite---phone-systems-plus--inc>)

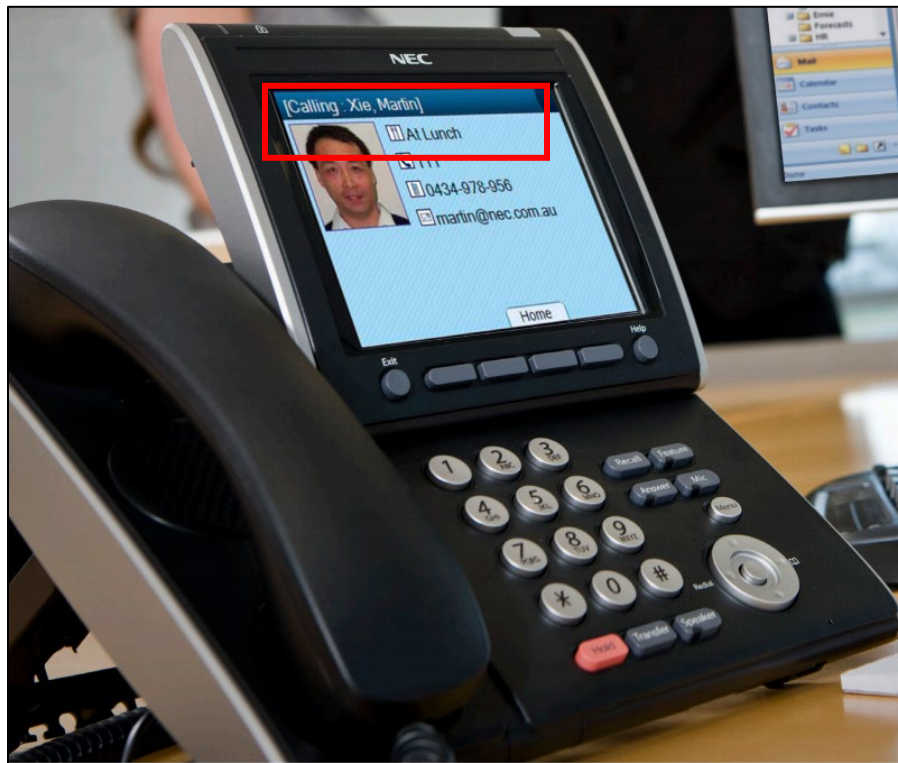

(Source: <https://www.necam.com/docs/?id=0c154583-ea5d-4add-b92f-432a195455bf>)



(Source: <https://www.necam.com/docs/?id=0c154583-ea5d-4add-b92f-432a195455bf>)



(Source http://advancedtel.com/wp-content/uploads/2014/10/8100DesktopSuite_Brochure.pdf)

105. Far North Patents only asserts method claims from the '802 Patent.

106. NEC has had knowledge of the '802 Patent at least as of the date when it was notified of the filing of this action.

107. Far North Patents has been damaged as a result of the infringing conduct by NEC alleged above. Thus, NEC is liable to Far North Patents in an amount that adequately compensates it for such infringements, which, by law, cannot be less than a reasonable royalty, together with interest and costs as fixed by this Court under 35 U.S.C. § 284.

108. Far North Patents and/or its predecessors-in-interest have satisfied all statutory obligations required to collect pre-filing damages for the full period allowed by law for infringement of the '802 Patent.

COUNT IX

DIRECT INFRINGEMENT OF U.S. PATENT NO. 7,149,517

109. On December 12, 2006, United States Patent No. 7,149,517 (“the ‘517 Patent”) was duly and legally issued by the United States Patent and Trademark Office for an invention entitled “Methods and Systems for Implementation of the Calling Name Delivery Service Through Use of a Location Register in a Network Element in a Wireless Network.”

110. Far North Patents is the owner of the ‘517 Patent, with all substantive rights in and to that patent, including the sole and exclusive right to prosecute this action and enforce the ‘517 Patent against infringers, and to collect damages for all relevant times.

111. NEC made, had made, used, imported, provided, supplied, distributed, sold, and/or offered for sale products and/or systems including, for example, its NEC UC Desktop Suite, NEC UNIVERGE SV8100, NEC UNIVERGE SV9100, and NEC SL2100 families of products that include calling name services for mobile phones (collectively, “accused products”):

Empowered by Innovation **NEC**

UC Desktop Suite



(Source : https://www.nuteltech.com/productcatalog/nec/pdf/uc_desktop_suite.pdf)

UC Desktop Suite is a unified communications solution designed specifically for the UNIVERGE SV8100 Communications Server that enhances an organization's efficiency and productivity.

(Source : https://www.nuteltech.com/productcatalog/nec/pdf/uc_desktop_suite.pdf)

UNIVERGE SV8100



IP Telephony For Your Business

The UNIVERGE SV8100 Communications Server is the ideal system for Small and Medium Businesses (SMBs) requiring a versatile, feature-rich role-based Unified Communications (UC) solution that is completely scalable to grow together your company to meet the communications needs both now and in the future.

(Source : https://my.nec.com/en_MY/products/iptelephony/univerge/sv8100.html)

Using Caller ID Routing, the Mobile Extension user can call into the SV8100 Communication Server, gain system dial tone and use the convenient SV8100 station features. Outgoing calls made using this method will present the caller ID assigned to the user's mobile extension, which enables Mobile Extension users to protect the privacy of their home or cell phone numbers.

(Source : http://www.armstrongtelecom.com/download/nec_sv8100_applications/Mobile-Extension.pdf)



(Source : <https://www.nec-enterprise.com/documents?id=184&hash=4989c54687f461d54abc78924731d802254ef35934ce2f644990fd5afea9bac9>)

Unify Your Communications, Messaging and Collaboration

NEC's UC Suite delivers on the promise of unifying your business's communications by managing them through UC clients on your personal computer (PC) or mobile devices. The UC Suite Desktop and Web Client allows your employees to get more done in less time by providing them easy access to features such as hold, transfer, conference, enhanced park, page and barge-in. It also provides them with:

- Call management, speed dialing and contact lookup
- Presence to view colleague's real-time status and availability
- Visual voicemail for quick access to and easy management of inbox and messages
- Instant messaging capabilities for quick, real-time conversations
- Attendant console capabilities directly on an operator's PC, allowing them to transfer and manage calls on-screen
- Detailed call history reports—includes incoming calls, outgoing calls, call date and time, call duration and caller ID information

(Source : <https://www.necam.com/docs/?id=503D8D78-200D-482A-B35C-7AA272208D22>)

Information sheet

Orchestrating a brighter world **NEC**

Smart communications for
Small Businesses, SoHo and more

SL2100 Communication System

The image is a dark blue rectangular banner with white and orange text. It features the NEC logo and tagline at the top right, and the product name 'SL2100 Communication System' in large white font at the bottom. There are decorative orange curved lines on the right side.

(Source : <https://www.nec-enterprise.com/documents?id=1293&hash=abbed09d1528bc3940f5e6b93fd529e4b03d9f97e8abfb785ca4854be7eb3758>)

Stay connected while on the move

With Mobile Extension, you can take your office number with you when you're on the move. It provides you access to system features such as caller ID, call transfer and voicemail and it really is like being in the office, whether you're traveling or sitting in traffic.

- > Company specialists can now be empowered to maintain high service standards when out of the office since they remain reachable via a single number from any location.
- > Salespeople can use Mobile Extension to ensure that even when they're on the road, they never miss a call which could lead to a lucrative business opportunity.

(Source :

https://www.nec.com/en/global/solutions/univerge/support_downloads/pdf/SL2100_Brochure_NEC_UNIVERGE_eng.pdf)

112. By doing so, NEC has directly infringed (literally and/or under the doctrine of equivalents) at least Claim 7 of the '517 Patent. NEC's infringement in this regard is ongoing.

113. NEC has infringed the '517 Patent by using the accused products and thereby practicing a method for a location register (LR) of a network element in a wireless network to provide information associated with a wireless unit. For example, the accused products provide a unified communications solution designed to increase efficiency of enterprise communications. UC Desktop Suite uses Univerge SV8100 communication server. SV8100 provides a mobile extension feature to extend the capabilities of desktop application to mobile phones (wireless units). Further, SV8100 can be integrated with CRM applications, to retrieve a caller's information from a database (location register).

UC Desktop Suite is a unified communications solution designed specifically for the UNIVERGE SV8100 Communications Server that enhances an organization's efficiency and productivity.

(Source: https://cdn2.hubspot.net/hub/219364/file-302961996-pdf/documents/Brochures/UC_Desktop_Suite.pdf)

Stay Connected and Productive while On the Go

Through your mobile phone or laptop web-browser, UC Desktop Suite enables you to access and change your status, search for contacts by name and view their presence status to immediately know if they are available, access additional profile information of contacts, and simply click a contact to place a call – providing quick access to the people you need to reach.

(Source: https://cdn2.hubspot.net/hub/219364/file-302961996-pdf/documents/Brochures/UC_Desktop_Suite.pdf)

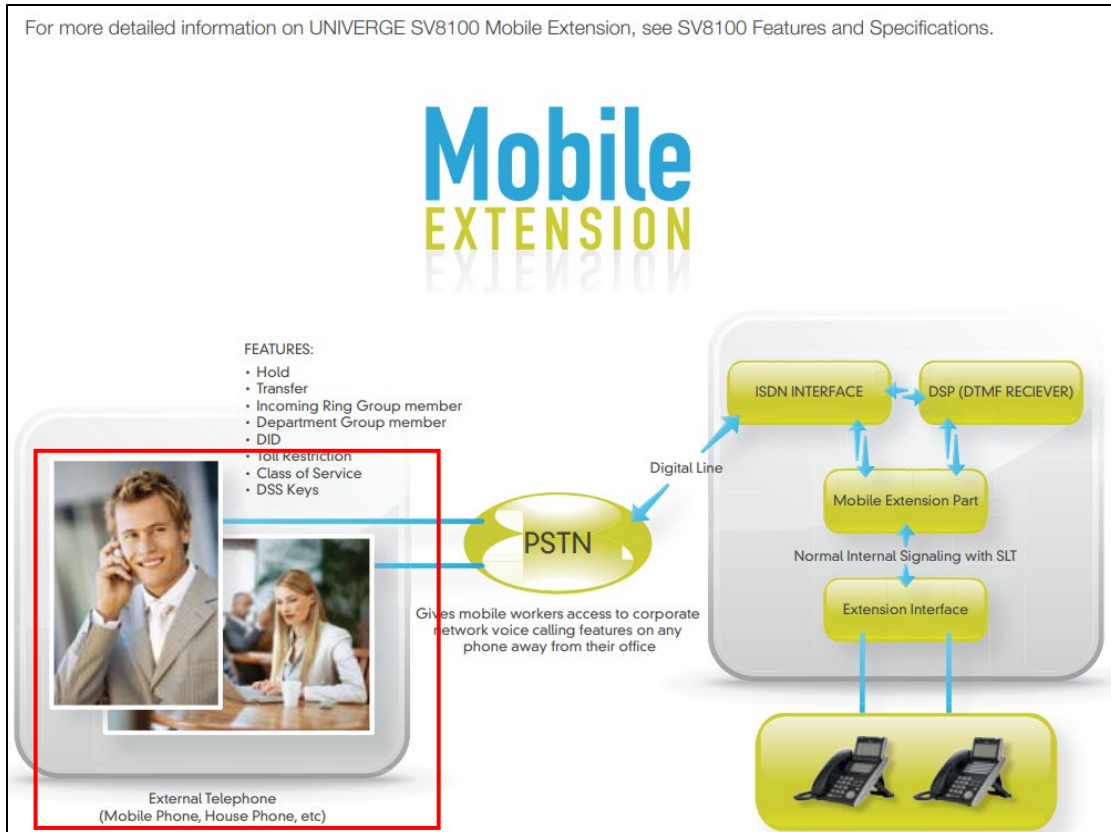

(Source: http://www.armstrongtelecom.com/download/nec_sv8100_applications/Mobile-Extension.pdf)

For organizations to thrive, they must be flexible. Customers have come to expect full service from their retailers, care providers, hospitality services and educational institutions 24 hours a day, 7 days a week. Now NEC can ensure you have the tools to stay competitive – wherever you are– with UNIVERGE SV8100 Mobile Extension.

Mobile Extension gives you access to all of the features of your desktop phone from nearly any external communications device. It enables you to use a mobile phone, home phone or other external device to simulate an extension of your office phone. And customers never know you're not at the office! One number access lets them reach you wherever you are.

(Source: http://www.armstrongtelecom.com/download/nec_sv8100_applications/Mobile-Extension.pdf)

CRM Integration - The SV8100 interacts with popular contact and CRM applications as well as Microsoft® Outlook. It can connect to company databases providing instant access to customer information.

(Source: http://www.portal-comms.co.uk/sites/default/files/SV8100_web.pdf)

UC Desktop Client's integration with popular contact and CRM applications*, including Outlook, Goldmine® and ACT!®, offer businesses seamless application access to the information that they need. It allows users to leverage and manage their information more efficiently.

SV8100 Communications Servers can be configured to perform a search in the user's CRM application database when a call comes in and then display a contact window with the caller's contact information. This feature dramatically improves customer service and satisfaction by enabling users to reference existing customer information rather than collecting it again.

This integration also provides users with access to standard call features from within Salesforce.com® and Time Matters® (a client and information management software). When an incoming call is received, an automatic search of the application's contact database is performed.

(Source: https://cdn2.hubspot.net/hub/219364/file-302961996-pdf/documents/Brochures/UC_Desktop_Suite.pdf)

Using Caller ID Routing, the Mobile Extension user can call into the SV8100 Communication Server, gain system dial tone and use the convenient SV8100 station features. Outgoing calls made using this method will present the caller ID assigned to the user's mobile extension, which enables Mobile Extension users to protect the privacy of their home or cell phone numbers.

(Source: http://www.armstrongtelecom.com/download/nec_sv8100_applications/Mobile-Extension.pdf)

Issue 5.02	UNIVERGE SV8100
<p style="text-align: center;"><i>TAPI Compatibility</i></p> <p>The system has Telephony Applications Programming Interface (TAPI) compatibility that provides:</p> <ul style="list-style-type: none"><input type="checkbox"/> Reduced TAPI Feature set<input type="checkbox"/> Caller ID data to the PC for data base lookups and screen pops<input type="checkbox"/> Telephone control (off-hook, on-hook and dialing) <p>The 1st-Party TAPI Ethernet driver provides an interface that allows the user personalized control of the telephone system from a desktop or laptop PC when used in conjunction with a TAPI-compliant application. The telephone system and PC are connected by installing an adapter on the telephone multiline terminal, allowing the PC user to access sophisticated communications services via the telephone lines.</p>	

(Source: <http://www.armstrongtelecom.com/download/NEC-SV8100-Manual/nec-sv8100-general-description-manual.pdf>)

Screen-pops - Prompted automatically by a call, operators view Caller ID as well as customer information even before answering, transforming your customer service.

(Source: http://www.portal-comms.co.uk/sites/default/files/SV8100_web.pdf)

- LED indicates ringing (colour coding for different departments), new voicemails and missed calls
- **Caller ID can provide incoming callers name and number**

(Source: http://www.portal-comms.co.uk/sites/default/files/SV8100_web.pdf)

• **Screen-pops** - Detailed caller ID information can be viewed before answering a call. This enables a more personal service such as greeting a caller by name, and responding more quickly to requests. Calls from top customers can also be prioritised.

(Source: <https://www.southern-comms.co.uk/wp-content/uploads/2015/09/nec-ucb-console.pdf>)

114. The methods practiced by NEC's use of the accused products include causing the LR to include a plurality of entries with each entry including an identifier and corresponding respectively to a wireless unit, each identifier of an entry being associated with information corresponding respectively to the wireless unit. For example, the accused products use Univerge SV8100 communication server which is integrated with CRM applications to retrieve caller's information from a database (location register). The database comprises of multiple users' information (plurality of entries). Each mobile extension of a user is associated with caller ID (identifier corresponding to a wireless unit). When a call is placed from a mobile phone (wireless unit) to any desk phone, the caller ID (identifier) is used to search (query) for caller name (information associated with identifier) in the database. The caller's name is displayed as a pop-up after retrieving the information from the database.

UC Desktop Client's integration with popular contact and CRM applications*, including Outlook, Goldmine® and ACT!®, offer businesses seamless application access to the information that they need. It allows users to leverage and manage their information more efficiently.

SV8100 Communications Servers can be configured to perform a search in the user's CRM application database when a call comes in and then display a contact window with the caller's contact information. This feature dramatically improves customer service and satisfaction by enabling users to reference existing customer information rather than collecting it again.

This integration also provides users with access to standard call features from within Salesforce.com® and Time Matters® (a client and information management software). When an incoming call is received, an automatic search of the application's contact database is performed.

(Source: https://cdn2.hubspot.net/hub/219364/file-302961996-pdf/documents/Brochures/UC_Desktop_Suite.pdf)

Using Caller ID Routing, the Mobile Extension user can call into the SV8100 Communication Server, gain system dial tone and use the convenient SV8100 station features. Outgoing calls made using this method will present the caller ID assigned to the user's mobile extension, which enables Mobile Extension users to protect the privacy of their home or cell phone numbers.

(Source: http://www.armstrongtelecom.com/download/nec_sv8100_applications/Mobile-Extension.pdf)

Issue 5.02	UNIVERGE SV8100
<p><i>TAPI Compatibility</i></p> <p>The system has Telephony Applications Programming Interface (TAPI) compatibility that provides:</p> <ul style="list-style-type: none"><input type="checkbox"/> Reduced TAPI Feature set<input type="checkbox"/> Caller ID data to the PC for data base lookups and screen pops<input type="checkbox"/> Telephone control (off-hook, on-hook and dialing) <p>The 1st-Party TAPI Ethernet driver provides an interface that allows the user personalized control of the telephone system from a desktop or laptop PC when used in conjunction with a TAPI-compliant application. The telephone system and PC are connected by installing an adapter on the telephone multiline terminal, allowing the PC user to access sophisticated communications services via the telephone lines.</p>	

(Source: <http://www.armstrongtelecom.com/download/NEC-SV8100-Manual/nec-sv8100-general-description-manual.pdf>)

- LED indicates ringing (colour coding for different departments), new voicemails and missed calls
- Caller ID can provide incoming callers name and number

(Source: http://www.portal-comms.co.uk/sites/default/files/SV8100_web.pdf)

115. The methods practiced by NEC's use of the accused products include causing the LR in response to receipt of a query including the identifier to use the identifier to find an entry having the identifier in common with the query. For example, in the accused products, the mobile extensions of users are associated with their corresponding caller ID (identifier). When a call is placed from a mobile phone to any desk phone, the caller ID (identifier) is used to search (query) for caller name in the database (LR).

UC Desktop Client's integration with popular contact and CRM applications*, including Outlook, Goldmine® and ACT!®, offer businesses seamless application access to the information that they need. It allows users to leverage and manage their information more efficiently.

SV8100 Communications Servers can be configured to perform a search in the user's CRM application database when a call comes in and then display a contact window with the caller's contact information. This feature dramatically improves customer service and satisfaction by enabling users to reference existing customer information rather than collecting it again.

This integration also provides users with access to standard call features from within Salesforce.com® and Time Matters® (a client and information management software). When an incoming call is received, an automatic search of the application's contact database is performed.

(Source: https://cdn2.hubspot.net/hub/219364/file-302961996-pdf/documents/Brochures/UC_Desktop_Suite.pdf)

Using Caller ID Routing, the Mobile Extension user can call into the SV8100 Communication Server, gain system dial tone and use the convenient SV8100 station features. Outgoing calls made using this method will present the caller ID assigned to the user's mobile extension, which enables Mobile Extension users to protect the privacy of their home or cell phone numbers.

(Source: http://www.armstrongtelecom.com/download/nec_sv8100_applications/Mobile-Extension.pdf)

Issue 5.02	UNIVERGE SV8100
<p style="text-align: center;"><i>TAPI Compatibility</i></p> <p>The system has Telephony Applications Programming Interface (TAPI) compatibility that provides:</p> <ul style="list-style-type: none"><input type="checkbox"/> Reduced TAPI Feature set<input checked="" type="checkbox"/> Caller ID data to the PC for data base lookups and screen pops<input type="checkbox"/> Telephone control (off-hook, on-hook and dialing) <p>The 1st-Party TAPI Ethernet driver provides an interface that allows the user personalized control of the telephone system from a desktop or laptop PC when used in conjunction with a TAPI-compliant application. The telephone system and PC are connected by installing an adapter on the telephone multiline terminal, allowing the PC user to access sophisticated communications services via the telephone lines.</p>	

(Source: <http://www.armstrongtelecom.com/download/NEC-SV8100-Manual/nec-sv8100-general-description-manual.pdf>)

- LED indicates ringing (colour coding for different departments), new voicemails and missed calls
- Caller iD can provide incoming callers name and number

(Source: http://www.portal-comms.co.uk/sites/default/files/SV8100_web.pdf)

116. The methods practiced by NEC's use of the accused products include, based on the information being associated with the identifier of the entry, causing the LR to retrieve the information corresponding to the wireless unit. For example, when a call is placed from a mobile phone (wireless unit) to any desk phone, the caller ID (identifier) is used to search (query) for caller name (information associated with identifier) in the database (LR). The caller's name is retrieved from the database.

UC Desktop Client's integration with CRM applications like Microsoft® Office Outlook® simplifies your attendant's job by displaying caller information retrieved from the integrated application's database. As always, your attendant is free to work on additional projects on their PC without ever missing a call or interrupting other work.

(Source: https://cdn2.hubspot.net/hub/219364/file-302961996-pdf/documents/Brochures/UC_Desktop_Suite.pdf)

UC Desktop Client's integration with popular contact and CRM applications*, including Outlook, Goldmine® and ACT!®, offer businesses seamless application access to the information that they need. It allows users to leverage and manage their information more efficiently.

SV8100 Communications Servers can be configured to perform a search in the user's CRM application database when a call comes in and then display a contact window with the caller's contact information. This feature dramatically improves customer service and satisfaction by enabling users to reference existing customer information rather than collecting it again.

This integration also provides users with access to standard call features from within Salesforce.com® and Time Matters® (a client and information management software). When an incoming call is received, an automatic search of the application's contact database is performed.

(Source: https://cdn2.hubspot.net/hub/219364/file-302961996-pdf/documents/Brochures/UC_Desktop_Suite.pdf)

Screen-pops - Prompted automatically by a call, operators view Caller ID as well as customer information even before answering, transforming your customer service.

(Source: http://www.portal-comms.co.uk/sites/default/files/SV8100_web.pdf)

- **Screen-pops** - Detailed caller ID information can be viewed before answering a call. This enables a more personal service such as greeting a caller by name, and responding more quickly to requests. Calls from top customers can also be prioritised.

(Source: <https://www.southern-comms.co.uk/wp-content/uploads/2015/09/nec-ucb-console.pdf>)

117. The methods practiced by NEC's use of the accused products include causing the LR to provide the information in a response to the query. For example, when a call is placed from a mobile phone to any desk phone, the caller ID is used to search (query) for caller name (information) in the database (LR). The caller's name is displayed as a pop-up after retrieving the information from the database.

UC Desktop Client's integration with CRM applications like Microsoft® Office Outlook® simplifies your attendant's job by displaying caller information retrieved from the integrated application's database. As always, your attendant is free to work on additional projects on their PC without ever missing a call or interrupting other work.

(Source: https://cdn2.hubspot.net/hub/219364/file-302961996-pdf/documents/Brochures/UC_Desktop_Suite.pdf)

UC Desktop Client's integration with popular contact and CRM applications*, including Outlook, Goldmine® and ACT!®, offer businesses seamless application access to the information that they need. It allows users to leverage and manage their information more efficiently.

SV8100 Communications Servers can be configured to perform a search in the user's CRM application database when a call comes in and then display a contact window with the caller's contact information. This feature dramatically improves customer service and satisfaction by enabling users to reference existing customer information rather than collecting it again.

This integration also provides users with access to standard call features from within Salesforce.com® and Time Matters® (a client and information management software). When an incoming call is received, an automatic search of the application's contact database is performed.

(Source: https://cdn2.hubspot.net/hub/219364/file-302961996-pdf/documents/Brochures/UC_Desktop_Suite.pdf)

Screen-pops - Prompted automatically by a call, operators view Caller ID as well as customer information even before answering, transforming your customer service.

(Source: http://www.portal-comms.co.uk/sites/default/files/SV8100_web.pdf)

• **Screen-pops** - Detailed caller ID information can be viewed before answering a call. This enables a more personal service such as greeting a caller by name, and responding more quickly to requests. Calls from top customers can also be prioritised.

(Source: <https://www.southern-comms.co.uk/wp-content/uploads/2015/09/nec-ucb-console.pdf>)

118. Far North Patents only asserts method claims from the '517 Patent.

119. NEC has had knowledge of the '517 Patent at least as of the date when it was notified of the filing of this action.

120. Far North Patents has been damaged as a result of the infringing conduct by NEC alleged above. Thus, NEC is liable to Far North Patents in an amount that adequately

compensates it for such infringements, which, by law, cannot be less than a reasonable royalty, together with interest and costs as fixed by this Court under 35 U.S.C. § 284.

121. Far North Patents and/or its predecessors-in-interest have satisfied all statutory obligations required to collect pre-filing damages for the full period allowed by law for infringement of the ‘517 Patent.

COUNT X

DIRECT INFRINGEMENT OF U.S. PATENT NO. 6,618,588

122. On September 9, 2003, United States Patent No. 6,618,588 (“the ‘588 Patent”) was duly and legally issued by the United States Patent and Trademark Office for an invention entitled “Methods and Systems for Implementation of the Calling Name Delivery Service Through Use of a Location Register in a Network Element in a Wireless Network.”

123. Far North Patents is the owner of the ‘588 Patent, with all substantive rights in and to that patent, including the sole and exclusive right to prosecute this action and enforce the ‘588 Patent against infringers, and to collect damages for all relevant times.

124. NEC made, had made, used, imported, provided, supplied, distributed, sold, and/or offered for sale products and/or systems including, for example, its NEC UC Desktop Suite, NEC UNIVERGE SV8100, NEC UNIVERGE SV9100, and NEC SL2100 families of products that include calling name services for mobile phones (collectively, “accused products”):

Empowered by Innovation



UC Desktop Suite

(Source : https://www.nuteltech.com/productcatalog/nec/pdf/uc_desktop_suite.pdf)

UC Desktop Suite is a unified communications solution designed specifically for the UNIVERGE SV8100 Communications Server that enhances an organization's efficiency and productivity.

(Source : https://www.nuteltech.com/productcatalog/nec/pdf/uc_desktop_suite.pdf)

UNIVERGE SV8100



IP Telephony For Your Business

The UNIVERGE SV8100 Communications Server is the ideal system for Small and Medium Businesses (SMBs) requiring a versatile, feature-rich role-based Unified Communications (UC) solution that is completely scalable to grow together your company to meet the communications needs both now and in the future.

(Source : https://my.nec.com/en_MY/products/iptelephony/univerge/sv8100.html)

Using Caller ID Routing, the Mobile Extension user can call into the SV8100 Communication Server, gain system dial tone and use the convenient SV8100 station features. Outgoing calls made using this method will present the caller ID assigned to the user's mobile extension, which enables Mobile Extension users to protect the privacy of their home or cell phone numbers.

(Source : http://www.armstrongtelecom.com/download/nec_sv8100_applications/Mobile-Extension.pdf)



(Source : <https://www.nec-enterprise.com/documents?id=184&hash=4989c54687f461d54abc78924731d802254ef35934ce2f644990fd5afea9bac9>)

Unify Your Communications, Messaging and Collaboration

NEC's UC Suite delivers on the promise of unifying your business's communications by managing them through UC clients on your personal computer (PC) or mobile devices. The UC Suite Desktop and Web Client allows your employees to get more done in less time by providing them easy access to features such as hold, transfer, conference, enhanced park, page and barge-in. It also provides them with:

- Call management, speed dialing and contact lookup
- Presence to view colleague's real-time status and availability
- Visual voicemail for quick access to and easy management of inbox and messages
- Instant messaging capabilities for quick, real-time conversations
- Attendant console capabilities directly on an operator's PC, allowing them to transfer and manage calls on-screen
- Detailed call history reports—includes incoming calls, outgoing calls, call date and time, call duration and caller ID information

(Source : <https://www.necam.com/docs/?id=503D8D78-200D-482A-B35C-7AA272208D22>)

Information sheet

Orchestrating a brighter world **NEC**

Smart communications for
Small Businesses, SoHo and more

SL2100 Communication System

(Source : <https://www.nec-enterprise.com/documents?id=1293&hash=abbed09d1528bc3940f5e6b93fd529e4b03d9f97e8abfb785ca4854be7eb3758>)

Stay connected while on the move

With Mobile Extension, you can take your office number with you when you're on the move. It provides you access to system features such as caller ID, call transfer and voicemail and it really is like being in the office, whether you're traveling or sitting in traffic.

- > Company specialists can now be empowered to maintain high service standards when out of the office since they remain reachable via a single number from any location.
- > Salespeople can use Mobile Extension to ensure that even when they're on the road, they never miss a call which could lead to a lucrative business opportunity.

(Source :

https://www.nec.com/en/global/solutions/univerge/support_downloads/pdf/SL2100_Brochure_NEC_UNIVERGE_eng.pdf)

125. By doing so, NEC has directly infringed (literally and/or under the doctrine of equivalents) at least Claim 5 of the '588 Patent. NEC's infringement in this regard is ongoing.

126. NEC has infringed the '588 Patent by using the accused products and thereby practicing a method for a location register (LR) of a network element in a wireless network to provide information associated with a wireless unit including causing the LR to include a plurality of entries with each entry including a mobile identity number (MIN) and/or a mobile directory number (MDN) and corresponding respectively to a wireless unit, each MIN and/or MDN of an entry being associated with information corresponding respectively to the wireless unit, wherein the information comprises a presentation allowance with respect to a name, the MIN and/or the MDN. For example, the accused products provide a unified communications solution designed to increase efficiency of enterprise communications. UC Desktop Suite uses Univerge SV8100 communication server. SV8100 provides a mobile extension feature to extend the capabilities of desktop application to mobile phones. Further, SV8100 can be integrated with

CRM applications, to retrieve a caller's information from a database (location register). The database comprises multiple users' information (plurality of entries). Each mobile extension of a user is associated with caller ID (Mobile Identification Number (MIN)). When a call is placed from a mobile phone to any desk phone, the caller ID (MIN) is used to search (query) for caller name (information associated with MIN) in the database. Here, caller has an option to choose whether to show caller id details to other users (presentation allowance).

UC Desktop Suite is a unified communications solution designed specifically for the UNIVERGE SV8100 Communications Server that enhances an organization's efficiency and productivity.

(Source: https://cdn2.hubspot.net/hub/219364/file-302961996-pdf/documents/Brochures/UC_Desktop_Suite.pdf)

Stay Connected and Productive while On the Go

Through your mobile phone or laptop web-browser, UC Desktop Suite enables you to access and change your status, search for contacts by name and view their presence status to immediately know if they are available, access additional profile information of contacts, and simply click a contact to place a call – providing quick access to the people you need to reach.

(Source: https://cdn2.hubspot.net/hub/219364/file-302961996-pdf/documents/Brochures/UC_Desktop_Suite.pdf)

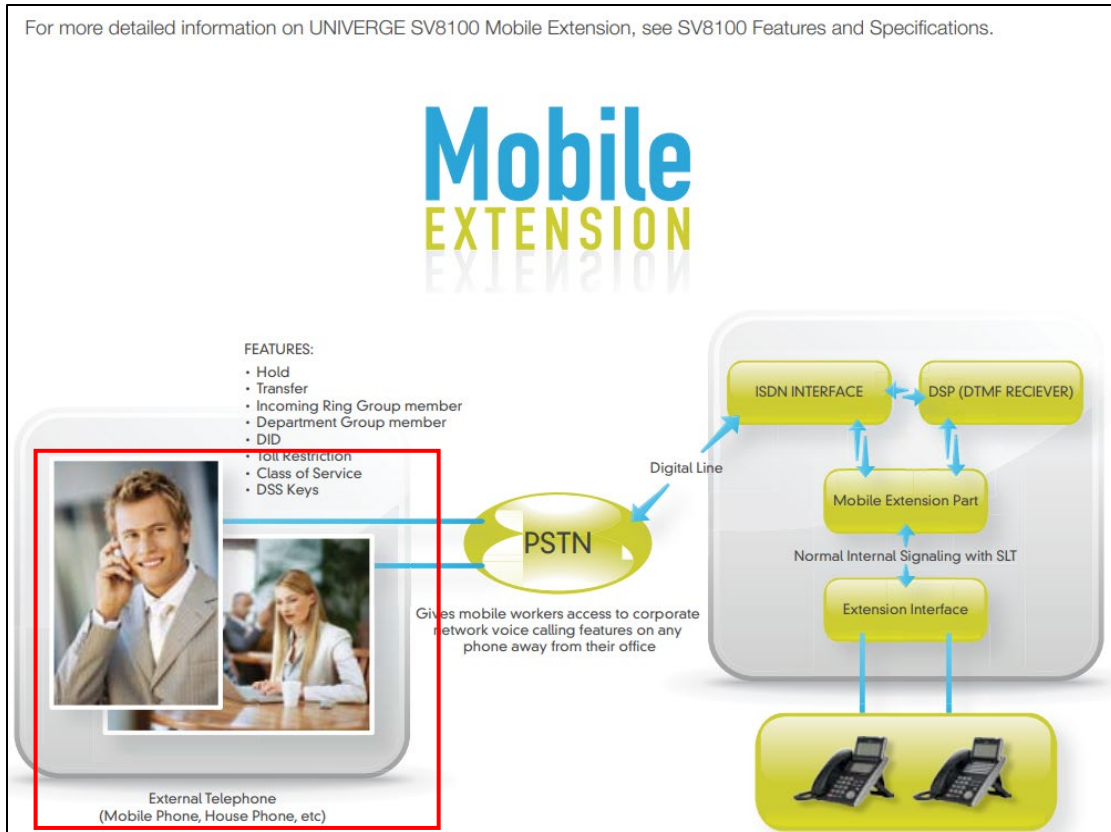

(Source: http://www.armstrongtelecom.com/download/nec_sv8100_applications/Mobile-Extension.pdf)

For organizations to thrive, they must be flexible. Customers have come to expect full service from their retailers, care providers, hospitality services and educational institutions 24 hours a day, 7 days a week. Now NEC can ensure you have the tools to stay competitive – wherever you are– with UNIVERGE SV8100 Mobile Extension.

Mobile Extension gives you access to all of the features of your desktop phone from nearly any external communications device. It enables you to use a mobile phone, home phone or other external device to simulate an extension of your office phone. And customers never know you're not at the office! One number access lets them reach you wherever you are.

(Source: http://www.armstrongtelecom.com/download/nec_sv8100_applications/Mobile-Extension.pdf)

CRM Integration - The SV8100 interacts with popular contact and CRM applications as well as Microsoft® Outlook. It can connect to company databases providing instant access to customer information.

(Source: http://www.portal-comms.co.uk/sites/default/files/SV8100_web.pdf)

UC Desktop Client's integration with popular contact and CRM applications*, including Outlook, Goldmine® and ACT!®, offer businesses seamless application access to the information that they need. It allows users to leverage and manage their information more efficiently.

SV8100 Communications Servers can be configured to perform a search in the user's CRM application database when a call comes in and then display a contact window with the caller's contact information. This feature dramatically improves customer service and satisfaction by enabling users to reference existing customer information rather than collecting it again.

This integration also provides users with access to standard call features from within Salesforce.com® and Time Matters® (a client and information management software). When an incoming call is received, an automatic search of the application's contact database is performed.

(Source: https://cdn2.hubspot.net/hub/219364/file-302961996-pdf/documents/Brochures/UC_Desktop_Suite.pdf)

Using Caller ID Routing, the Mobile Extension user can call into the SV8100 Communication Server, gain system dial tone and use the convenient SV8100 station features. Outgoing calls made using this method will present the caller ID assigned to the user's mobile extension, which enables Mobile Extension users to protect the privacy of their home or cell phone numbers.

(Source: http://www.armstrongtelecom.com/download/nec_sv8100_applications/Mobile-Extension.pdf)

Issue 5.02	UNIVERGE SV8100
<p style="text-align: center;"><i>TAPI Compatibility</i></p> <p>The system has Telephony Applications Programming Interface (TAPI) compatibility that provides:</p> <ul style="list-style-type: none"><input type="checkbox"/> Reduced TAPI Feature set<input type="checkbox"/> Caller ID data to the PC for data base lookups and screen pops<input type="checkbox"/> Telephone control (off-hook, on-hook and dialing) <p>The 1st-Party TAPI Ethernet driver provides an interface that allows the user personalized control of the telephone system from a desktop or laptop PC when used in conjunction with a TAPI-compliant application. The telephone system and PC are connected by installing an adapter on the telephone multiline terminal, allowing the PC user to access sophisticated communications services via the telephone lines.</p>	

(Source: <http://www.armstrongtelecom.com/download/NEC-SV8100-Manual/nec-sv8100-general-description-manual.pdf>)

Screen-pops - Prompted automatically by a call, operators view Caller ID as well as customer information even before answering, transforming your customer service.

(Source: http://www.portal-comms.co.uk/sites/default/files/SV8100_web.pdf)

- LED indicates ringing (colour coding for different departments), new voicemails and missed calls
- **Caller ID can provide incoming callers name and number**

(Source: http://www.portal-comms.co.uk/sites/default/files/SV8100_web.pdf)

• **Screen-pops** - Detailed caller ID information can be viewed before answering a call. This enables a more personal service such as greeting a caller by name, and responding more quickly to requests. Calls from top customers can also be prioritised.

(Source: <https://www.southern-comms.co.uk/wp-content/uploads/2015/09/nec-ucb-console.pdf>)

Related Programs

° 20-09-02 : Class of Service Options (Incoming Call Service) - Caller ID Display
Define the option whether display Caller ID or not in each station port.

Item No.	Item	Input data	Default	
			COS 01-14	COS 15
02	Caller ID Display Enables/disables the Caller ID display at an extension.	0-Off 1-On	1	1

(Source: <https://www.manualslib.com/manual/1207495/Nec-Univerge-Sv9100.html?page=620>)

127. The methods practiced by NEC's use of the accused products include causing the LR in response to receipt of a query including the MIN and/or the MDN to use the MIN and/or the MDN to find an entry having the MIN and/or the MDN in common with the query and checking that the information associated with the MIN and/or the MDN of the entry comprises the presentation allowance. For example, the mobile extensions of users are associated with their corresponding caller ID (MIN). When a call is placed from a mobile phone to any desk phone, the caller ID (MIN) is used to search (query) for a caller name (information associated with MIN) in the database (LR). Here, a caller has an option to choose whether to show caller id details to other users (presentation allowance).

UC Desktop Client's integration with popular contact and CRM applications*, including Outlook, Goldmine® and ACT!®, offer businesses seamless application access to the information that they need. It allows users to leverage and manage their information more efficiently.

SV8100 Communications Servers can be configured to perform a search in the user's CRM application database when a call comes in and then display a contact window with the caller's contact information. This feature dramatically improves customer service and satisfaction by enabling users to reference existing customer information rather than collecting it again.

This integration also provides users with access to standard call features from within Salesforce.com® and Time Matters® (a client and information management software). When an incoming call is received, an automatic search of the application's contact database is performed.

(Source: https://cdn2.hubspot.net/hub/219364/file-302961996-pdf/documents/Brochures/UC_Desktop_Suite.pdf)

Using Caller ID Routing, the Mobile Extension user can call into the SV8100 Communication Server, gain system dial tone and use the convenient SV8100 station features. Outgoing calls made using this method will present the caller ID assigned to the user's mobile extension, which enables Mobile Extension users to protect the privacy of their home or cell phone numbers.

(Source: http://www.armstrongtelecom.com/download/nec_sv8100_applications/Mobile-Extension.pdf)

Issue 5.02	UNIVERGE SV8100
<p style="text-align: center;"><i>TAPI Compatibility</i></p> <p>The system has Telephony Applications Programming Interface (TAPI) compatibility that provides:</p> <ul style="list-style-type: none"><input type="checkbox"/> Reduced TAPI Feature set<input checked="" type="checkbox"/> Caller ID data to the PC for data base lookups and screen pops<input type="checkbox"/> Telephone control (off-hook, on-hook and dialing) <p>The 1st-Party TAPI Ethernet driver provides an interface that allows the user personalized control of the telephone system from a desktop or laptop PC when used in conjunction with a TAPI-compliant application. The telephone system and PC are connected by installing an adapter on the telephone multiline terminal, allowing the PC user to access sophisticated communications services via the telephone lines.</p>	

(Source: <http://www.armstrongtelecom.com/download/NEC-SV8100-Manual/nec-sv8100-general-description-manual.pdf>)

- LED indicates ringing (colour coding for different departments), new voicemails and missed calls
- Caller ID can provide incoming callers name and number**

(Source: http://www.portal-comms.co.uk/sites/default/files/SV8100_web.pdf)

Related Programs

- 20-09-02 : Class of Service Options (Incoming Call Service) - Caller ID Display
Define the option whether display Caller ID or not in each station port.

Item No.	Item	Input data	Default	
			COS 01-14	COS 15
02	Caller ID Display Enables/disables the Caller ID display at an extension.	0-Off 1-On	1	1

(Source: <https://www.manualslib.com/manual/1207495/Nec-Univerge-Sv9100.html?page=620>)

128. The methods practiced by NEC’s use of the accused products include, based on the information being associated with the MIN and/or the MDN of the entry, causing the LR to retrieve the information corresponding to the wireless unit and causing the LR to provide the information in a response to the query. For example, the mobile extensions of users are associated with their corresponding caller ID. When a call is placed from a mobile phone (wireless unit) to any desk phone, the caller ID (MIN) is used to search (query) for caller name (information associated with MIN) in the database and caller ID information gets retrieved (retrieval of caller name information).

Stay Connected and Productive while On the Go

Through your mobile phone or laptop web-browser, UC Desktop Suite enables you to access and change your status, search for contacts by name and view their presence status to immediately know if they are available, access additional profile information of contacts, and simply click a contact to place a call – providing quick access to the people you need to reach.

(Source: https://cdn2.hubspot.net/hub/219364/file-302961996-pdf/documents/Brochures/UC_Desktop_Suite.pdf)

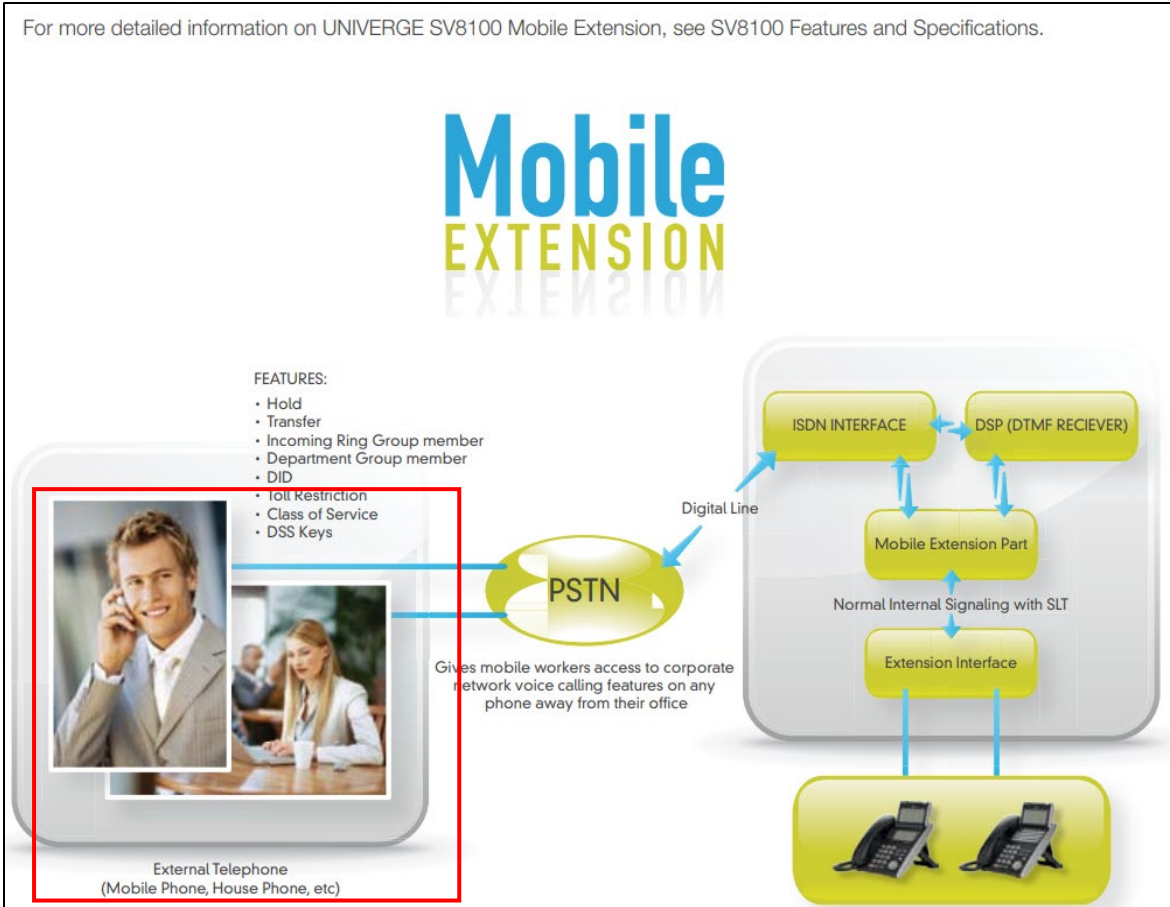

(Source: http://www.armstrongtelecom.com/download/nec_sv8100_applications/Mobile-Extension.pdf)

For organizations to thrive, they must be flexible. Customers have come to expect full service from their retailers, care providers, hospitality services and educational institutions 24 hours a day, 7 days a week. Now NEC can ensure you have the tools to stay competitive – wherever you are– with UNIVERGE SV8100 Mobile Extension.

Mobile Extension gives you access to all of the features of your desktop phone from nearly any external communications device. It enables you to use a mobile phone, home phone or other external device to simulate an extension of your office phone. And customers never know you're not at the office! One number access lets them reach you wherever you are.

(Source: http://www.armstrongtelecom.com/download/nec_sv8100_applications/Mobile-Extension.pdf)

UC Desktop Client's integration with CRM applications like Microsoft® Office Outlook® simplifies your attendant's job by displaying caller information retrieved from the integrated application's database. As always, your attendant is free to work on additional projects on their PC without ever missing a call or interrupting other work.

(Source: https://cdn2.hubspot.net/hub/219364/file-302961996-pdf/documents/Brochures/UC_Desktop_Suite.pdf)

UC Desktop Client's integration with popular contact and CRM applications*, including Outlook, Goldmine® and ACT!®, offer businesses seamless application access to the information that they need. It allows users to leverage and manage their information more efficiently.

SV8100 Communications Servers can be configured to perform a search in the user's CRM application database when a call comes in and then display a contact window with the caller's contact information. This feature dramatically improves customer service and satisfaction by enabling users to reference existing customer information rather than collecting it again.

This integration also provides users with access to standard call features from within Salesforce.com® and Time Matters® (a client and information management software). When an incoming call is received, an automatic search of the application's contact database is performed.

(Source: https://cdn2.hubspot.net/hub/219364/file-302961996-pdf/documents/Brochures/UC_Desktop_Suite.pdf)

Screen-pops - Prompted automatically by a call, operators view Caller ID as well as customer information even before answering, transforming your customer service.

(Source: http://www.portal-comms.co.uk/sites/default/files/SV8100_web.pdf)

- **Screen-pops** - Detailed caller ID information can be viewed before answering a call. This enables a more personal service such as greeting a caller by name, and responding more quickly to requests. Calls from top customers can also be prioritised.

(Source: <https://www.southern-comms.co.uk/wp-content/uploads/2015/09/nec-ucb-console.pdf>)

129. Far North Patents only asserts method claims from the ‘588 Patent.

130. NEC has had knowledge of the ‘588 Patent at least as of the date when it was notified of the filing of this action.

131. Far North Patents has been damaged as a result of the infringing conduct by NEC alleged above. Thus, NEC is liable to Far North Patents in an amount that adequately compensates it for such infringements, which, by law, cannot be less than a reasonable royalty, together with interest and costs as fixed by this Court under 35 U.S.C. § 284.

132. Far North Patents and/or its predecessors-in-interest have satisfied all statutory obligations required to collect pre-filing damages for the full period allowed by law for infringement of the ‘588 Patent.

ADDITIONAL ALLEGATIONS REGARDING INFRINGEMENT

133. NEC has also indirectly infringed the ‘105 Patent, the ‘437 Patent, the ‘230 Patent, the ‘053 Patent, the ‘702 Patent, the ‘797 Patent, the ‘770 Patent, the ‘802 Patent, the ‘517 Patent, and the ‘588 Patent by inducing others to directly infringe the ‘105 Patent, the ‘437 Patent, the ‘230 Patent, the ‘053 Patent, the ‘702 Patent, the ‘797 Patent, the ‘770 Patent, the ‘802 Patent, the ‘517 Patent, and the ‘588 Patent. NEC has induced the end-users, NEC’s customers, to directly infringe (literally and/or under the doctrine of equivalents) the ‘105 Patent,

the '437 Patent, the '230 Patent, the '053 Patent, the '702 Patent, the '797 Patent, the '770 Patent, the '802 Patent, the '517 Patent, and the '588 Patent by using the accused products.

134. NEC took active steps, directly and/or through contractual relationships with others, with the specific intent to cause them to use the accused products in a manner that infringes one or more claims of the patents-in-suit, including, for example, Claims 1 and 23 of the '105 Patent, Claim 9 of the '437 Patent, Claim 1 of the '230 Patent, Claims 1 and 14 of the '053 Patent, Claim 27 of the '702 Patent, Claim 30 of the '797 Patent, Claim 1 of the '770 Patent, Claim 5 of the '802 Patent, Claim 7 of the '517 Patent, and Claim 5 of the '588 Patent.

135. Such steps by NEC included, among other things, advising or directing customers and end-users to use the accused products in an infringing manner; advertising and promoting the use of the accused products in an infringing manner; and/or distributing instructions that guide users to use the accused products in an infringing manner.

136. NEC has performed these steps, which constitute induced infringement, with the knowledge of the '105 Patent, the '437 Patent, the '230 Patent, the '053 Patent, the '702 Patent, the '797 Patent, the '770 Patent, the '802 Patent, the '517 Patent, and the '588 Patent and with the knowledge that the induced acts constitute infringement.

137. NEC was and is aware that the normal and customary use of the accused products by NEC's customers would infringe the '105 Patent, the '437 Patent, the '230 Patent, the '053 Patent, the '702 Patent, the '797 Patent, the '770 Patent, the '802 Patent, the '517 Patent, and the '588 Patent. NEC's inducement is ongoing.

138. NEC has also induced its affiliates, or third-party manufacturers, shippers, distributors, retailers, or other persons acting on its or its affiliates' behalf, to directly infringe (literally and/or under the doctrine of equivalents) the '105 Patent, the '437 Patent, the '230

Patent, the '053 Patent, the '702 Patent, the '797 Patent, the '770 Patent, the '802 Patent, the '517 Patent, and the '588 Patent by importing, selling or offering to sell the accused products.

139. NEC has at least a significant role in placing the accused products in the stream of commerce in Texas and elsewhere in the United States.

140. NEC directs or controls the making of accused products and their shipment to the United States, using established distribution channels, for sale in Texas and elsewhere within the United States.

141. NEC directs or controls the sale of the accused products into established United States distribution channels, including sales to nationwide retailers.

142. NEC's established United States distribution channels include one or more United States based affiliates (e.g., at least NEC Corporation of America).

143. NEC directs or controls the sale of the accused products in nationwide retailers such as CDW, including for sale in Texas and elsewhere in the United States, and expects and intends that the accused products will be so sold.

144. NEC took active steps, directly and/or through contractual relationships with others, with the specific intent to cause such persons to import, sell, or offer to sell the accused products in a manner that infringes one or more claims of the patents-in-suit, including, for example, Claims 1 and 23 of the '105 Patent, Claim 9 of the '437 Patent, Claim 1 of the '230 Patent, Claims 1 and 14 of the '053 Patent, Claim 27 of the '702 Patent, Claim 30 of the '797 Patent, Claim 1 of the '770 Patent, Claim 5 of the '802 Patent, Claim 7 of the '517 Patent, and Claim 5 of the '588 Patent.

145. Such steps by NEC included, among other things, making or selling the accused products outside of the United States for importation into or sale in the United States, or knowing

that such importation or sale would occur; and directing, facilitating, or influencing its affiliates, or third-party manufacturers, shippers, distributors, retailers, or other persons acting on its or their behalf, to import, sell, or offer to sell the accused products in an infringing manner.

146. NEC performed these steps, which constitute induced infringement, with the knowledge of the '105 Patent, the '437 Patent, the '230 Patent, the '053 Patent, the '702 Patent, the '797 Patent, the '770 Patent, the '802 Patent, the '517 Patent, and the '588 Patent and with the knowledge that the induced acts would constitute infringement.

147. NEC performed such steps in order to profit from the eventual sale of the accused products in the United States.

148. NEC's inducement is ongoing.

149. NEC has also indirectly infringed by contributing to the infringement of the '105 Patent, the '437 Patent, the '230 Patent, the '053 Patent, the '702 Patent, the '797 Patent, the '770 Patent, the '802 Patent, the '517 Patent, and the '588 Patent. NEC has contributed to the direct infringement of the '105 Patent, the '437 Patent, the '230 Patent, the '053 Patent, the '702 Patent, the '797 Patent, the '770 Patent, the '802 Patent, the '517 Patent, and the '588 Patent by the end-user of the accused products.

150. The accused products have special features that are specially designed to be used in an infringing way and that have no substantial uses other than ones that infringe the '105 Patent, the '437 Patent, the '230 Patent, the '053 Patent, the '702 Patent, the '797 Patent, the '770 Patent, the '802 Patent, the '517 Patent, and the '588 Patent, including, for example, Claims 1 and 23 of the '105 Patent, Claim 9 of the '437 Patent, Claim 1 of the '230 Patent, Claims 1 and 14 of the '053 Patent, Claim 27 of the '702 Patent, Claim 30 of the '797 Patent, Claim 1 of the

‘770 Patent, Claim 5 of the ‘802 Patent, Claim 7 of the ‘517 Patent, and Claim 5 of the ‘588 Patent.

151. The special features include advanced quality monitoring capabilities, advanced quality of service capabilities, advanced presence information capabilities, and calling name services for mobile phones, used in a manner that infringes the ‘105 Patent, the ‘437 Patent, the ‘230 Patent, the ‘053 Patent, the ‘702 Patent, the ‘797 Patent, the ‘770 Patent, the ‘802 Patent, the ‘517 Patent, and the ‘588 Patent.

152. The special features constitute a material part of the invention of one or more of the claims of the ‘105 Patent, the ‘437 Patent, the ‘230 Patent, the ‘053 Patent, the ‘702 Patent, the ‘797 Patent, the ‘770 Patent, the ‘802 Patent, the ‘517 Patent, and the ‘588 Patent and are not staple articles of commerce suitable for substantial non-infringing use.

153. NEC’s contributory infringement is ongoing.

154. Furthermore, NEC has a policy or practice of not reviewing the patents of others (including instructing its employees to not review the patents of others), and thus has been willfully blind of Far North Patents’ patent rights. *See, e.g.*, M. Lemley, “Ignoring Patents,” 2008 Mich. St. L. Rev. 19 (2008).

155. NEC’s actions are at least objectively reckless as to the risk of infringing valid patents and this objective risk was either known or should have been known by NEC.

156. NEC has knowledge of the ‘105 Patent, the ‘437 Patent, the ‘230 Patent, the ‘053 Patent, the ‘702 Patent, the ‘797 Patent, the ‘770 Patent, the ‘802 Patent, the ‘517 Patent, and the ‘588 Patent.

157. NEC's customers have infringed the '105 Patent, the '437 Patent, the '230 Patent, the '053 Patent, the '702 Patent, the '797 Patent, the '770 Patent, the '802 Patent, the '517 Patent, and the '588 Patent.

158. NEC encouraged its customers' infringement.

159. NEC's direct and indirect infringement of the '105 Patent, the '437 Patent, the '230 Patent, the '053 Patent, the '702 Patent, the '797 Patent, the '770 Patent, the '802 Patent, the '517 Patent, and the '588 Patent is, has been, and/or continues to be willful, intentional, deliberate, and/or in conscious disregard of Far North Patents' rights under the patents.

160. Far North Patents has been damaged as a result of the infringing conduct by NEC alleged above. Thus, NEC is liable to Far North Patents in an amount that adequately compensates it for such infringements, which, by law, cannot be less than a reasonable royalty, together with interest and costs as fixed by this Court under 35 U.S.C. § 284.

JURY DEMAND

Far North Patents hereby requests a trial by jury on all issues so triable by right.

PRAYER FOR RELIEF

Far North Patents requests that the Court find in its favor and against NEC, and that the Court grant Far North Patents the following relief:

a. Judgment that one or more claims of the '105 Patent, the '437 Patent, the '230 Patent, the '053 Patent, the '702 Patent, the '797 Patent, the '770 Patent, the '802 Patent, the '517 Patent, and the '588 Patent have been infringed, either literally and/or under the doctrine of equivalents, by NEC and/or all others acting in concert therewith;

b. A permanent injunction enjoining NEC and its officers, directors, agents, servants, affiliates, employees, divisions, branches, subsidiaries, parents, and all others acting in

concert therewith from infringement of the '105 Patent, the '437 Patent, the '230 Patent, and the '053 Patent; or, in the alternative, an award of a reasonable ongoing royalty for future infringement of the '105 Patent, the '437 Patent, the '230 Patent, and the '053 Patent by such entities;

c. Judgment that NEC account for and pay to Far North Patents all damages to and costs incurred by Far North Patents because of NEC's infringing activities and other conduct complained of herein, including an award of all increased damages to which Far North Patents is entitled under 35 U.S.C. § 284;

d. That Far North Patents be granted pre-judgment and post-judgment interest on the damages caused by NEC's infringing activities and other conduct complained of herein;

e. That this Court declare this an exceptional case and award Far North Patents its reasonable attorney's fees and costs in accordance with 35 U.S.C. § 285; and

f. That Far North Patents be granted such other and further relief as the Court may deem just and proper under the circumstances.

Dated: December 26, 2019

Respectfully submitted,

/s/ Zachariah S. Harrington

Matthew J. Antonelli

Texas Bar No. 24068432

matt@ahtlawfirm.com

Zachariah S. Harrington

Texas Bar No. 24057886

zac@ahtlawfirm.com

Larry D. Thompson, Jr.

Texas Bar No. 24051428

larry@ahtlawfirm.com

Christopher Ryan Pinckney

Texas Bar No. 24067819

ryan@ahtlawfirm.com

ANTONELLI, HARRINGTON
& THOMPSON LLP

4306 Yoakum Blvd., Ste. 450
Houston, TX 77006
(713) 581-3000

Attorneys for Far North Patents, LLC