

UNITED STATES DISTRICT COURT  
WESTERN DISTRICT OF TEXAS  
WACO DIVISION

CASTLEMORTON WIRELESS, LLC,

*Plaintiff,*

V.

ALTICE USA, INC.; CEQUEL  
COMMUNICATIONS, LLC; AND CSC  
HOLDINGS, LLC,

*Defendants.*

Civil Action No. \_\_\_\_\_

**JURY TRIAL DEMANDED**

**COMPLAINT FOR PATENT INFRINGEMENT**

Castlemorton Wireless, LLC (“Castlemorton”) brings this action and makes the following allegations of patent infringement relating to U.S. Patent No.: 7,835,421 (the “’421 patent” or the “patent-in-suit”). Defendants Altice USA, Inc.; Cequel Communications, LLC; and CSC Holdings, LLC (collectively, “Altice” or “Defendant”) infringe the ‘421 patent in violation of the patent laws of the United States of America, 35 U.S.C. § 1 *et seq.*

**INTRODUCTION**

1. This case arises from Altice’s infringement of the ‘421 patent. The ‘421 patent claims priority to United Kingdom Patent App. No. 8300076, dated January 4, 1983.
2. The ‘421 patent arose from the work of Geoffrey Bagley, a researcher at the United Kingdom’s Ministry of Defence. The ‘421 patent discloses inventions relating to the detection of a carrier frequency of a direct spread spectrum signal (“DSSS”) in wireless communication.
3. The inventions disclosed in the ‘421 patent were breakthroughs in the field of carrier signal detection. In fact, the disclosures in the ‘421 patent were considered so novel and important by the British and United States governments that secrecy orders precluded publication

of the patented inventions for over twenty-five years. The below excerpt from the file history of the '421 patent shows the United Kingdom Secretary of State's Secrecy Order pursuant to Section 22(1) of the United Kingdom's Patent Act of 1977.

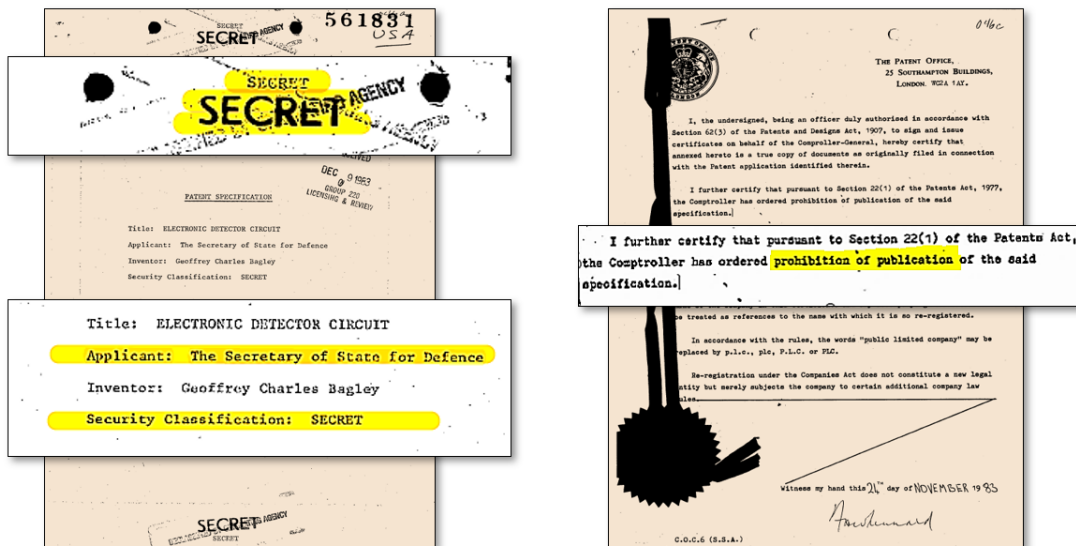

'421 Patent File History, CERTIFIED COPY OF FOREIGN PRIORITY APPLICATION (November 24, 1983) (emphasis added) ("I further certify that pursuant to Section 22(1) of the Patents Act, 1977, the Comptroller has ordered prohibition of publication of the said specification."); '421 Patent File History, Patent Specification Cover Page (December 9, 1983) (showing that the '421 Patent was applied for by the British Secretary of State for Defence and designated "Secret.").

4. The '421 patent was developed by Geoffrey Bagley of the Royal Signals and Radar Establishment ("RSRE"), a scientific research organization within the Ministry of Defence of the United Kingdom. The RSRE was the primary center for research and development of electronic devices and telecommunications technologies for the United Kingdom's Ministry of Defence.<sup>1</sup> As described below, RSRE's focus on wireless communications, encryption, electronic circuitry, and satellite tracking led to groundbreaking advancements in dual-use technologies (scientific applications with civilian and military function).

<sup>1</sup> F.F. Barnes and B.R. Holeman, *The Transfer of Defence Research on Electronic Materials to the Civil Field*, PHIL. TRANS. R. SOC. LOND. SERIES A VOL. 322, NO. 1567 at 335 (1987) ("The Royal Signals and Radar Establishment (RSRE) has for many years been the focus within the Ministry of Defence for research on electronic materials and devices.").

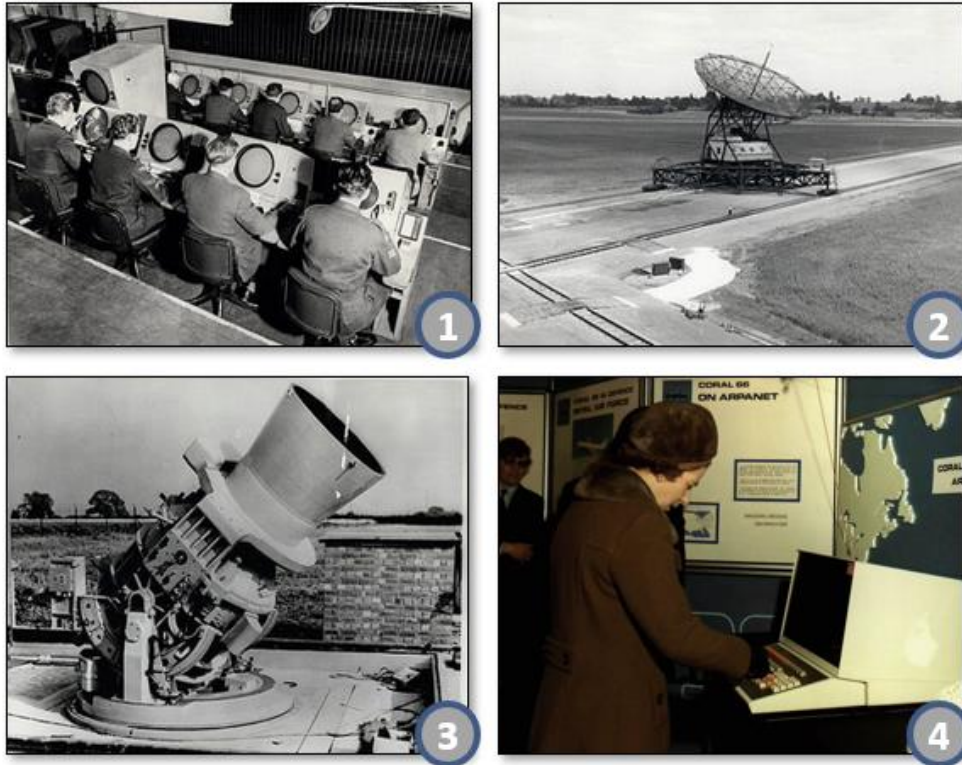

Images of RSRE's research programs: (1) the data extraction team at the RSRE (J.E.N. Hooper, *The Royal Radar Establishment*, ELECTRONICS AND POWER VOL. 13 Issue 5 at 154 (May 1967)); (2) tracking the Sputnik I rocket (I. Harris and R. Jastrow, *Re-Entry of the Sputnik I Rocket*, PLANET SPACE SCI., VOL. 1 at 1982 (1959) ("The observations on the Sputnik I rocket include a late radar echo obtained by the staff of the Royal Radar Establishment at Malvern, England.")); (3) an RSRE satellite camera for tracking satellites (Harrie Massie and M. O. Robin, HISTORY OF BRITISH SPACE SCIENCE at 261 (2009)); (4) email sent using ARPANET by Queen Elizabeth at the RSRE facility (Cade Metz, *How the Queen of England Beat Everyone to the Internet*, WIRED MAGAZINE (December 15, 2012) ("The date was March 26, 1976, and the ARPANET – the computer network that eventually morphed into the internet – had just come to the Royal Signals and Radar Establishment.")).

5. The RSRE played a pivotal role in the development of technologies with broad civilian applications. Technologies developed by the RSRE included integrated circuits,<sup>2</sup> thermal

<sup>2</sup> Mike Green, *Dummer's Vision of Solid Circuits at the UK Royal Radar Establishment*, IEEE Annals of the History of Computing 35 at 56 (2013) ("Geoffrey W.A. Dummer of the British Royal Radar Establishment (RRE) described his idea of semiconductor 'solid circuits' at a conference in Washington, DC in 1952.").

imaging,<sup>3</sup> gas lasers,<sup>4</sup> and touch-screen user interfaces.<sup>5</sup>

6. Geoffrey Bagley, the inventor of the '421 patent, conducted his work on wireless signal communication systems at the RSRE. Geoffrey Bagley's research in the field of wireless transmissions has been recognized as contributing to the "greatest technological advances" in the field.

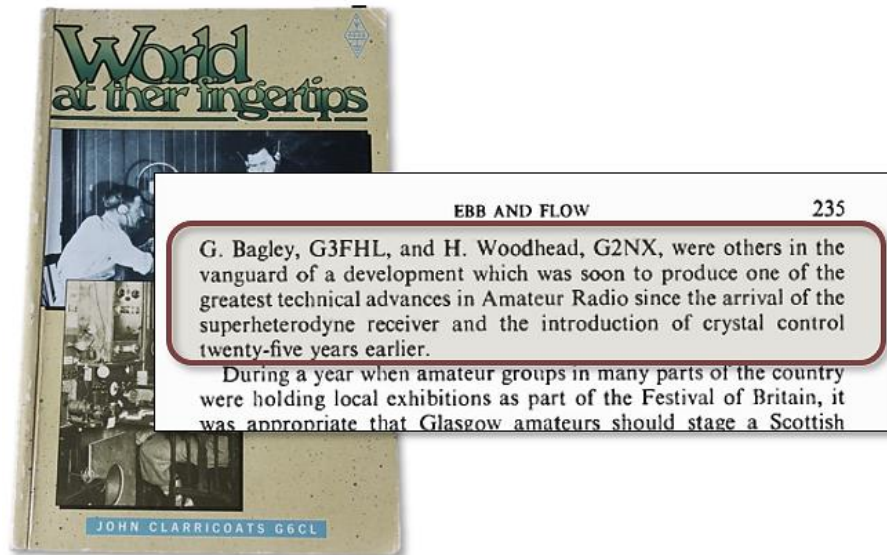

John Clarricoats, *WORLD AT THEIR FINGERTIPS* at 235 (1984) ("G. Bagley, G3FHL, and H. Woodhead, G2NX, were others in the vanguard of a development which was soon to produce one of the greatest technical advances in Amateur Radio since the arrival of the super heterodyne receiver and the introduction of crystal control twenty-five years earlier.").

7. In 1991, the RSRE was combined with other British defense research establishments into the United Kingdom Defence Research Agency ("DRA"). In 2001, the United Kingdom Ministry of Defence reorganized the research establishments of the DRA into QinetiQ,

<sup>3</sup> Steve Connor, *Military Moles Seek Technology Mountains*, *NEW SCIENTIST* at 39 (Aug. 7, 1986) ("The RSRE, for instance has pioneered thermal imaging to see in the dark, or in fog.").

<sup>4</sup> E.H Putley, *The History of the RSRE*, *PHYS. TECHNOL.*, VOL. 16 at 11 ("Laser Development. RSRE discovered molecular gas laser in 1963 and invented the first far-infrared laser.").

<sup>5</sup> Yuval Mor, *Emotions Analytics to Transform Human-Machine Interactions*, *WIRED MAGAZINE* (Sept. 2013) ("In the mid-60s, E.A. Johnson at the Royal Radar Establishment in Malvern (UK) created the first touch screen; that has since sparked completely new user experiences via a plethora of innovative applications.").

a corporation majority owned by the United Kingdom government.<sup>6</sup>

8. QinetiQ, in partnership with Castlemorton, seeks to monetize the inventions developed by the RSRE. The value of QinetiQ's inventions has been confirmed by QinetiQ's history of successful intellectual property enforcement actions. *See QinetiQ Limited v. Samsung Telecommunic, et al*, Case. No. 03-cv-00221, Dkt. No. 251 (E.D. Tex. Jan. 14, 2005) (awarding QinetiQ \$17,982,222 in damages against Samsung); *QinetiQ Limited v. Picvue Electronics, Ltd.*, Case No. 05-cv-00199, Dkt. No. 32 (E.D. Tex. Aug. 21, 2008) (entry of default judgment in the amount of \$9,175,958 in favor of QinetiQ); and *QinetiQ Limited v. Oclaro Inc.*, Case No. 10-cv-00080, Dkt. No. 119 (N.D. Cal. Dec. 6, 2010) (Oclaro entered into a license agreement to the asserted QinetiQ patent valued at roughly \$1.7 million).<sup>7</sup>

### **THE PARTIES**

#### **CASTLEMORTON WIRELESS, LLC**

9. Castlemorton Wireless, LLC ("Castlemorton" or "Plaintiff") is a limited liability company organized under the laws of Delaware. Castlemorton was formed to obtain compensation for RSRE's pioneering work in the field of wireless communications.

10. Castlemorton pursues the reasonable royalties owed for Altice's use of the inventions claimed in the '421 patent, which arise from RSRE's groundbreaking technology.

---

<sup>6</sup> R. Szweda, *SILICON GERMANIUM MATERIALS AND DEVICES: A MARKET AND TECHNOLOGY OVERVIEW* at 249 (2006) ("QinetiQ is a wholly UK government-owned pls that was formed in July 2001.").

<sup>7</sup> *See* OCLARO, INC. 2013 FORM 10-K at 52 (September 26, 2013) ("Legal settlements expense of \$1.7 million during the year ended July 2, 2011 includes amounts recorded in connection with a confidential settlement agreement with QinetiQ Limited and for other legal settlements and related legal costs.").

**ALTICE DEFENDANTS**

11. Altice USA, Inc. is a Delaware corporation with its principal place of business at One Court Square West, Long Island City, New York 11101. Altice USA may be served through its registered agent Corporation Service Company, 251 Little Falls Drive, Wilmington, Delaware 19808.

12. Cequel Communications, LLC is a Delaware limited liability company with its principal place of business at 520 Maryville Centre Drive, Suite 300, St. Louis, Missouri 63141. Cequel Communications, LLC may be served through its registered agent Corporation Service Company, 251 Little Falls Drive, Wilmington, Delaware 19808.

13. CSC Holdings, LLC is a Delaware limited liability company with its principal place of business at 1111 Stewart Avenue, Bethpage, New York 11714. CSC Holdings, LLC may be served through its registered agent Corporation Service Company, 251 Little Falls Drive, Wilmington, Delaware 19808.

14. Altice conducts business operations within the Western District of Texas in its facilities at 4402 Williams Dr., Suite 125, Georgetown, Texas 78628; 1504 N. Main, Monahans, Texas 79756; 2530 South Midkiff, Midland, Texas 79701; and 412 W. Broadway, Andrews, Texas 79714. Altice has offices in the Western District of Texas where it sells, develops, and/or markets its products.

**JURISDICTION AND VENUE**

15. This action arises under the patent laws of the United States, Title 35 of the United States Code. Accordingly, this Court has exclusive subject matter jurisdiction over this action under 28 U.S.C. §§ 1331 and 1338(a).

16. Upon information and belief, this Court has personal jurisdiction over Altice in this action because Altice has committed acts within the Western District of Texas giving rise to this action and has established minimum contacts with this forum such that the exercise of jurisdiction over Altice would not offend traditional notions of fair play and substantial justice. Defendant Altice, directly and/or through subsidiaries or intermediaries (including distributors, retailers, and others), has committed and continues to commit acts of infringement in this District by, among other things, offering to sell and selling products and/or services that infringe the patent-in-suit. Moreover, Altice has offices and facilities in the State of Texas, and actively directs its activities to customers located in the State of Texas.

17. Venue is proper in this district under 28 U.S.C. §§ 1391(b)-(d) and 1400(b). Defendant Altice has offices in the State of Texas, and upon information and belief, has transacted business in the Western District of Texas and has committed acts of direct and indirect infringement in the Western District of Texas.

#### **THE '421 PATENT**

18. The United States Department of Defense and the United Kingdom Secretary of State ordered the '421 patent and its associated foreign and domestic applications be subject to "Secrecy Orders," as disclosure of the '421 patent would be "detrimental to the national security"<sup>8</sup> and "prejudicial to the defence of the realm."<sup>9</sup>

19. Invention secrecy orders were first issued by the United States government in response to World War I. The Federal Government was concerned that "those inventions which are of most use to the Government during a time of war are also those which would, if known,

---

<sup>8</sup> See 35 U.S.C. § 181 (1952).

<sup>9</sup> See the UNITED KINGDOM PATENTS ACT § 22(1) (1977).

convey useful information to the enemy.”<sup>10</sup> These first secrecy orders were limited to the period of World War I. After World War I, the secrecy doctrine lay dormant for more than two decades. However, in 1940, in anticipation of the United States entry into World War II, the statute was renewed by the Act of July 1st, 1940.<sup>11</sup>

20. Following the end of World War II and with Cold War tensions mounting, Congress passed the Invention Secrecy Act of 1952. The 1952 Act created a year-long secrecy order, capable of indefinite renewal so long as the national interest required.<sup>12</sup>

21. On January 27, 1950, the United States and the Government of the United Kingdom of Great Britain and Northern Ireland entered into the Mutual Defence Assistance Agreement<sup>13</sup> in response to tensions with the Soviet Union. The agreement recognized the need to protect the secrecy of cutting-edge technology that could have important military, as well as civilian, capabilities and the need to advance the defense interests of the United States and the United Kingdom.

22. It was against this background that, on January 11, 1983, the United Kingdom Secretary of State ordered the foreign patent application to which the ‘421 patent claims priority be “classified by the defence authority of the United Kingdom as SECRET.” The secrecy designation made by the United Kingdom prohibited the disclosure of United Kingdom Patent App. No. 8300076.

---

<sup>10</sup> S. Rep. No. 119, 65th Cong., 1st Sess. at 1 (1917).

<sup>11</sup> Act of July 1, 1940, ch. 501, 54 Stat. 710 (1940).

<sup>12</sup> Invention Secrecy Act of 1952, ch. 4 §§10 & 11, 66 Stat. 3 (1952) (codified as amended at 35 U.S.C. §§ 181-188 (1994)).

<sup>13</sup> Interchange of Patent Rights and Technical Information, United States Treaties and Other International Acts Series 2773, UNITED STATES DEPARTMENT OF STATE, Publ. No. 5170 at 1 (Jan. 19, 1953).



23. The designation of the ‘421 patent application as subject to a Secrecy Order was unusual and underscores the importance of the inventions disclosed in the ‘421 patent. In 2010, the final year that the ‘421 patent application was subject to a Secrecy Order, the United States Patent and Trademark Office (“USPTO”) filed only 86 new secrecy orders<sup>14</sup> out of a total of 520,277 patent applications submitted to the USPTO.<sup>15</sup> Less than 0.016% (one out of every 6,049) patent applications was subject to a secrecy order in 2010.

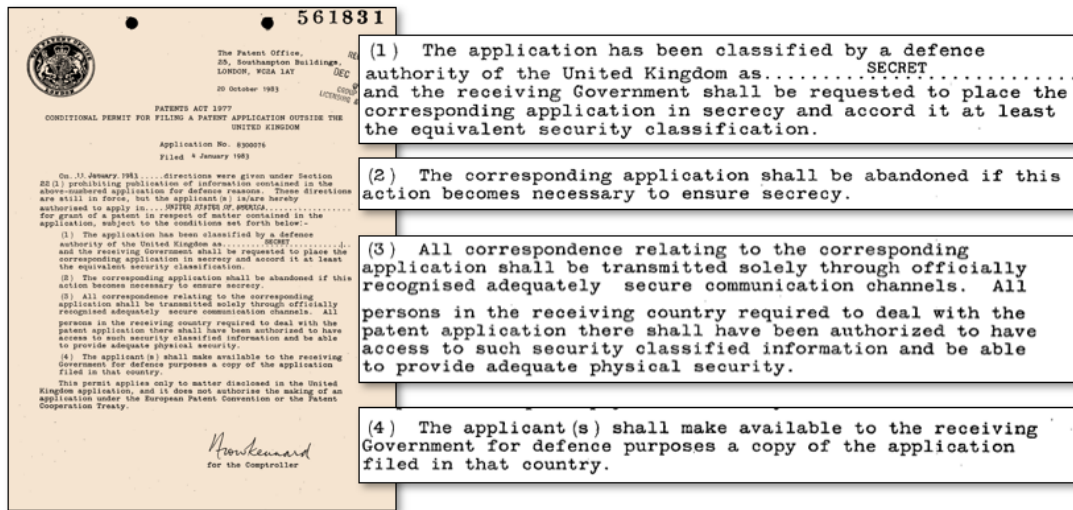

‘421 Patent File History, CONDITIONAL PERMIT FOR FILING A PATENT APPLICATION OUTSIDE THE UNITED KINGDOM (October 20, 1983) (“On 11 January 1983 directions were given under Section 22(1) prohibiting publication of information contained in the above-numbered application for defense reasons. These directions are still in force, but the applicant(s) is/are hereby authorized to apply in UNITED STATES OF AMERICA for grant of a patent in respect of matter contained in the application, subject to the conditions set forth below.”).

24. The United Kingdom’s designation of the ‘421 patent application as subject to a Secrecy Order was made pursuant to the United Kingdom Patent Act of 1977. The United Kingdom’s Patent Act of 1977 requires, where a patent “application contains information” and

<sup>14</sup> See FREEDOM OF INFORMATION ACT (FOIA) REQUEST NO. F-13-0004 at 5 (October 23, 2012) (response to the FOIA request of Steven Aftergood of the Federation of American Scientists).

<sup>15</sup> U.S. Patent Statistics Chart Calendar Years 1963-2018, U.S. PATENT AND TRADEMARK OFFICE PATENT TECHNOLOGY MONITORING TEAM (2019), available at: [https://www.uspto.gov/web/offices/ac/ido/oeip/taf/us\\_stat.htm](https://www.uspto.gov/web/offices/ac/ido/oeip/taf/us_stat.htm)

where the “publication of which might be prejudicial to the defence of the realm,” the patent application be prohibited from publication.

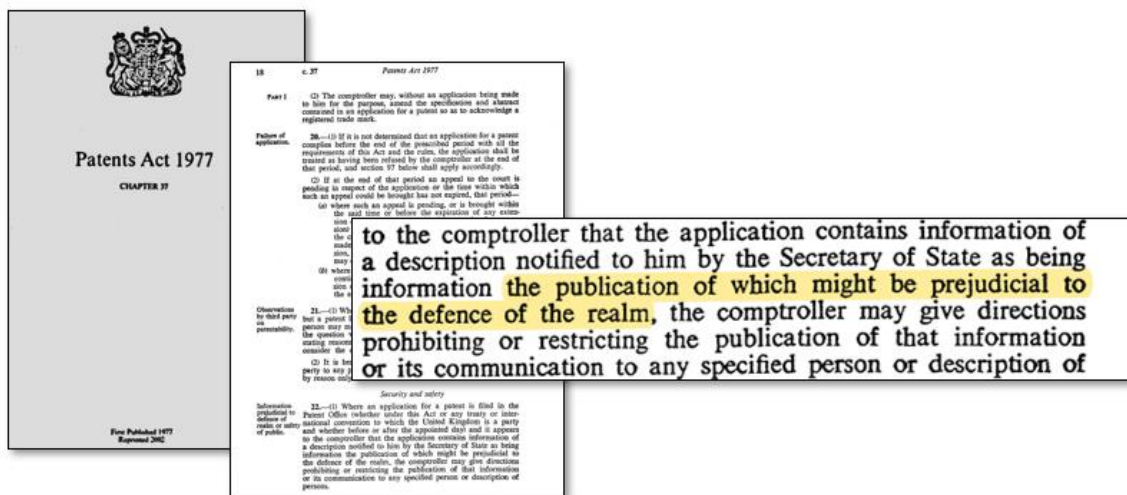

THE UNITED KINGDOM PATENTS ACT § 22(1) (1977) (emphasis added) (“the publication of which might be prejudicial to the defence of the realm”).

25. On December 9, 1983, the United States Department of Defense issued a Secrecy Order covering the inventions disclosed in the ‘421 patent application, independently confirming the importance of the ‘421 patent. The United States Department of Defense found pursuant to “Title 35, United States Code (1952), section 181-188” that the ‘421 patent application contained subject matter where “unauthorized disclosure of which might be detrimental to the national security.” Based on this finding, the Department of Defense entered a Secrecy Order on December 9, 1983. The Secrecy Order provided for criminal penalties should the ‘421 patent application be published without “written consent” of the “Commissioner of Patent and Trademarks.” See *‘421 Patent File History*, SECRECY ORDER (Filed December 9, 1983).

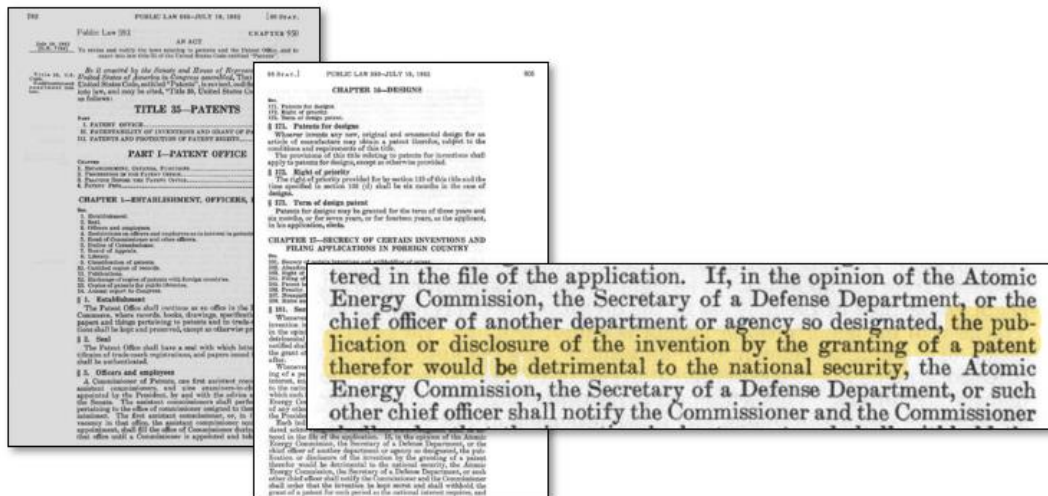

CHAPTER 17 OF THE PATENT ACT OF 1952, 35 U.S.C. § 181 (1952) (emphasis added) (Chapter 17 is sometimes referred to, by itself, as the Invention Secrecy Act because it was based on the Invention Secrecy Act of 1951, Pub. L. No. 82-256, 66 Stat. 3.).

26. The Patent Act of 1952 (under which the ‘421 patent application was designated as subject to a Secrecy Order) prohibits the publication of a patent application where the “publication or disclosure of the invention by the granting of a patent therefor would be detrimental to the national security.” The determination to designate the ‘421 patent application as subject to a Secrecy Order was made pursuant to the United States Department of Defense Patent Act of 1952 in United States Code, Sections 181-188. The following excerpt from the file history of the ‘421 patent shows the issuance of the initial “Secrecy Order” by the United States Department of Defense was based on a finding that the disclosure of the inventions in the ‘421 patent application would be “detrimental to national security.”

You are hereby notified that your application as above identified has been found to contain subject matter, the unauthorized disclosure of which might be detrimental to the national security, and you are ordered in nowise to publish or disclose the invention or any material information with respect thereto.

‘421 Patent File History, SECRECY ORDER (Filed December 9, 1983).

'421 Patent File History, SECRECY ORDER (Filed December 9, 1983) (emphasis added) (“You are hereby notified that your application as above identified has been found to contain subject matter, the unauthorized disclosure of which might be detrimental to the national security, and you are ordered in nowise to publish or disclose the invention or any material information.”).

27. Following the issuance of the Secrecy Order, the United States Armed Services Patent Advisor Board of the United States Department of Defense notified the United States Commissioner of Patents and Trademarks that it had made an “affirmative determination” that “the national interest require[d] renewal of the secrecy order.”

'421 Patent File History, RENEWAL OF SECRECY ORDER (Mailed July 3, 1985) (“The Armed Services Patent Advisory Board, Department of Defense (DOD), has notified the Commissioner of Patents and Trademarks that an affirmative determination has been made by a DOD agency, identified below, that the national interest requires renewal of the secrecy order.”).

28. During the following decade, the United States Department of Defense issued renewals of the Secrecy Order prohibiting disclosure of the application leading to the '421 patent. Repeatedly, the United States determined that disclosure of the inventions taught in the '421 patent would be detrimental to national security should they be published. *See '421 Patent File History, RENEWAL OF SECRECY ORDER (Mailed July 2, 1986); '421 Patent File History, RENEWAL OF SECRECY ORDER (Mailed July 2, 1987); '421 Patent File History, SECRECY ORDER AND PERMIT FOR DISCLOSING CLASSIFIED INFORMATION (July 7, 1988); '421 Patent File History, RENEWAL OF SECRECY ORDER (Mailed July 6, 1989); '421 Patent File History, SECRECY ORDER AND PERMIT FOR DISCLOSING CLASSIFIED INFORMATION (Mailed July 11, 1991); '421 Patent File History, RENEWAL OF SECRECY ORDER (Mailed July 1, 1992); '421 Patent File History, RENEWAL OF SECRECY ORDER (Mailed July 2, 1993); '421 Patent File History, RENEWAL OF SECRECY ORDER (Mailed July 6, 1994); and '421 Patent File History, RENEWAL OF SECRECY ORDER (Mailed July 6, 1995).*

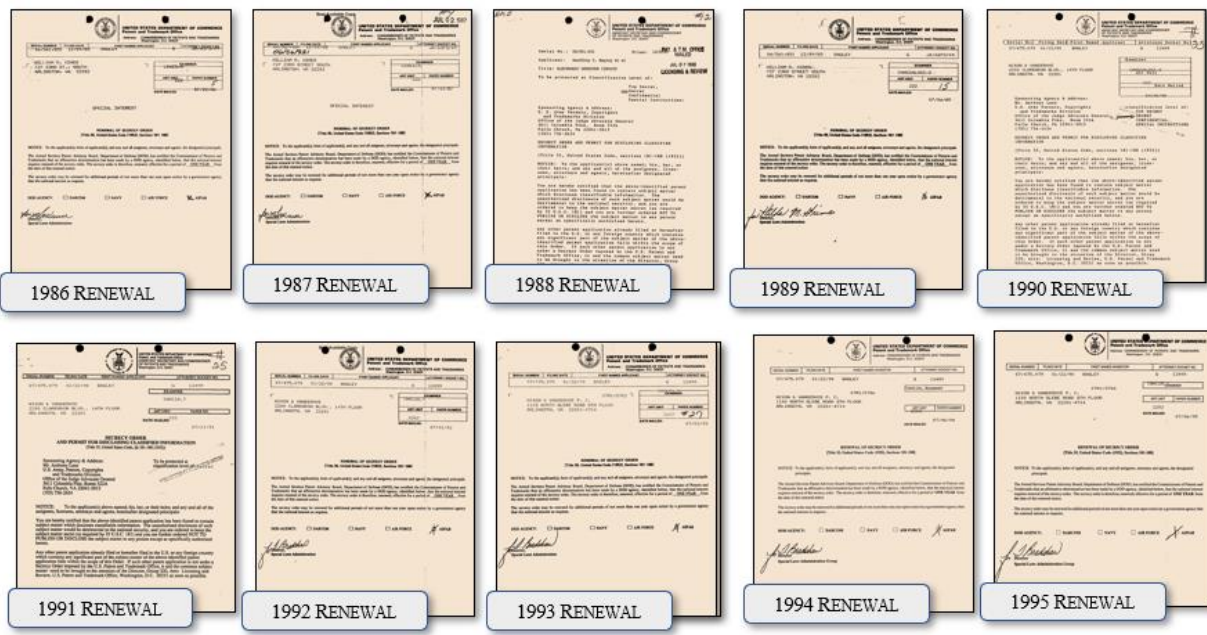

*'421 Patent File History, SECRECY ORDER RENEWALS (1986-1995) (annotation added).*

29. Each time the United States Department of Defense renewed the Secrecy Order, the patent applicant was notified that the '421 patent contained "subject matter which discloses classifiable information . . . the unauthorized disclosure of [which] . . . would be detrimental to the national security." An illustrative example of these annual renewal notifications is excerpted below.

Serial No.: 06/561,831 Filed: 12/ PAT & TM OFFICE  
 Applicant: Geoffrey C. Bagley et al. MAILED  
 Title: ELECTRONIC DETECTOR CIRCUIT JUL 07 1988  
 To be protected at Classification Level of: LICENSING & REVIEW  
 Top Secret,  
 XXX Secret  
 Confidential  
 Special Instructions:  
 Sponsoring Agency & Address:  
 U. S. Army Patent, Copyright  
 and Trademark Division  
 Office of the Judge Advocate General  
 3811 Columbia Pike, Room 332A  
 Falls Church, VA 22041-3013

You are hereby notified that the above-identified patent application has been found to contain subject matter which discloses classifiable information. The unauthorized disclosure of such subject matter would be detrimental to the national security, and you are ordered to keep the subject matter secret (as required by 35 U.S.C. 181) and you are further ordered NOT TO PUBLISH OR DISCLOSE the subject matter to any person except as specifically authorized herein.

Trademark Office, Washington, D.C. 20231 as soon as possible.  
 75 Years Strengthening America's Progress • 1913-1988

'421 Patent File History, SECRECY ORDER AND PERMIT FOR DISCLOSING CLASSIFIED INFORMATION (July 7, 1988) (emphasis added) ("You are hereby notified that the above-identified patent application has been found to contain subject matter which discloses classifiable information. The unauthorized disclosure of such subject matter would be detrimental to the national security, and you are ordered to keep the subject matter secret (as required by 35 U.S.C. 181) and you are further ordered NOT TO PUBLISH OR DISCLOSE the subject matter to any person except as specifically authorized herein.").

**THE INVENTIONS DISCLOSED IN THE '421 PATENT REFLECT GEOFFREY BAGLEY'S GROUND BREAKING WIRELESS COMMUNICATIONS RESEARCH**

30. Geoffrey Bagley was a pioneer in the field of wireless communication. Starting in the 1950's, he developed novel antenna designs and wireless signal processing systems. Geoffrey Bagley was a member of the Radio Society of Great Britain for over 70 years. See RADIO SOCIETY OF GREAT BRITAIN NEWSLETTER at 12 (January 2018).



WILLINGTON AMATEUR RADIO SOCIETY (A.R.S.) MEETING (Mid-1950s) (Geoffrey Bagley is picture standing second from the left in the rear of the photo).

31. Geoffrey Bagley's research centered on wireless communications systems including signal processing. Bagley wrote numerous papers in the field of wireless communications systems.<sup>16</sup> His research in the field has been widely cited by other researchers in

---

<sup>16</sup> See, e.g., G.C. Bagley, *Radar Pulse-Compression By Random Phase-Coding*, THE RADIO AND ELECTRONIC ENGINEER VOL. 36, ISSUE 1 (July 1968); G.C. Bagley, *Radar Signal Loss Resulting From Sub-Optimal Phase Quadrature Processing*, THE RADIO AND ELECTRONIC ENGINEER VOL. 47, ISSUE 5 (May 1977); G.C. Bagley, *Digital Processing Of Signal Phase-Angle*, IEEE TRANS. AEROSPACE AND ELECTRONIC SYST. AES-9 (1973); G.C. Bagley, *Reducing Heterodyne Interference: A Survey Of The Problems Of Heterodyne Interference, With Particular Reference To Single-Sideband Operation*, R.S.G.B. BULLETIN VOL. 28 NO. 6 at 239 (December 1952); G.C. Bagley, *An Aerial Module For The UHF Band*, *Institution of Electrical Engineers, Conference on Aerospace Antennas, London, England, June 8-10, 1971*, PROCEEDINGS IEE CONFERENCE PUBLICATION, NO. 77 at 66 (1971) (identifying G.C. Bagley as being employed at the Royal Aircraft Establishment in Farnborough, England); G.C. Bagley, *A Survey Of Cancellation Versus Integration For Radar Clutter Reflection*, NASA STI/RECON TECHNICAL REPORT N (August 1974); G.C. Bagley, *Review Of Secondary Radar - Fundamentals and Instrumentation*, THE AERONAUTICAL JOURNAL VOL. 81 ISSUE 795 at 133 (March 1977); G.C. Bagley, *Review of Radar Precision and Resolution*, THE AERONAUTICAL JOURNAL VOL. 79 ISSUE 771 at 139 (March 1975); G.C. Bagley, *Review of Introduction to Adaptive Arrays*, THE AERONAUTICAL JOURNAL VOL. 85 ISSUE 847 at 349 (September 1981); and G.C. Bagley, *Review of Radar Technology*, THE AERONAUTICAL JOURNAL VOL. 82 ISSUE 810 at 276 (June 1978).

peer-reviewed journals.<sup>17</sup>



SELECTION OF RESEARCH PAPERS BY GEOFFREY BAGLEY (published 1968 to 1981).

32. Geoffrey Bagley’s research informed his development of the inventions disclosed in the ‘421 patent. For example, his 1952 paper on reducing heterodyne interference examined ways that one could send a wireless communication over a channel that was used by other transmissions. A core problem Bagley identified was the need for a receiver to determine the transmitted communication from other communications that were sent over the same wireless

<sup>17</sup> See, e.g., J.M. Ross, *Coded Signal Design For A Transmitter Scanned Sonar*, JOURNAL OF SOUND AND VIBRATION Vol. 29 Issue 2 at 227 (July 1973); Herbert Matthews, SURFACE WAVE FILTERS: DESIGN, CONSTRUCTION, AND USE at 475 (1977); D.P. Morgan, *Surface Acoustic Wave Devices And Applications: 5. Signal Processing Using Programmable Non-Linear Convolver*, ULTRASONICS Vol. 12 Issue 2 at 74 (March 1974); Matthews, Herbert, SURFACE WAVE FILTERS: DESIGN, CONSTRUCTION, AND USE (1977); Frank Amoroso, *Adaptive A/D Converter To Suppress CW Interference In DSPN Spread-Spectrum Communications*, IEEE TRANSACTIONS ON COMMUNICATIONS VOL. 31 ISSUE 10 at 1117 (1983); Frank Amoroso, *Adaptive A/D Converter To Suppress Co-Channel Constant Envelope Interference In A Mobile Digital Link*, TELECOMMUNICATION SYSTEMS VOL. 2 ISSUE 1 at 109 (1993); J.J. Hill, *Design Of Nonrecursive Digital Moving-Target-Indicator Radar Filters*, ELECTRONICS LETTERS Vol. 8 Issue 14 at 359-360 (1972); P.F. Swaszek and J.B. Thomas, *Robust Vector Quantization*, OFFICE OF NAVAL RESEARCH REPORT NUMBER 10 at 14 (March 1983); and Frederick H. Raab and Jerome R. Waechter, *The Counting Phase Detector With VLF Atmospheric Noise*, IEEE TRANSACTIONS ON AEROSPACE AND ELECTRONIC SYSTEMS Issue 5 (Sept. 1977).



channel. Mr. Bagley would focus on these issues for much of his career. The need to disaggregate the wireless communication from other wireless transmissions would later be addressed by the inventions disclosed in the '421 patent.

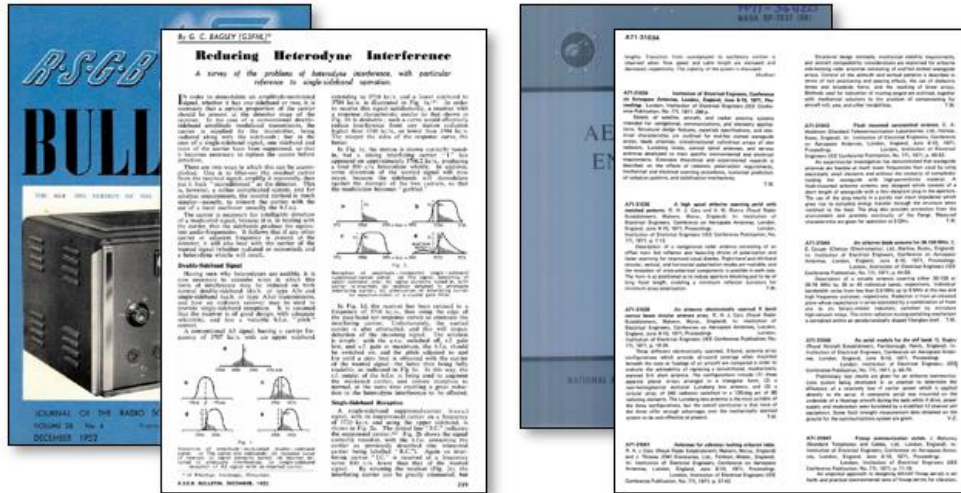
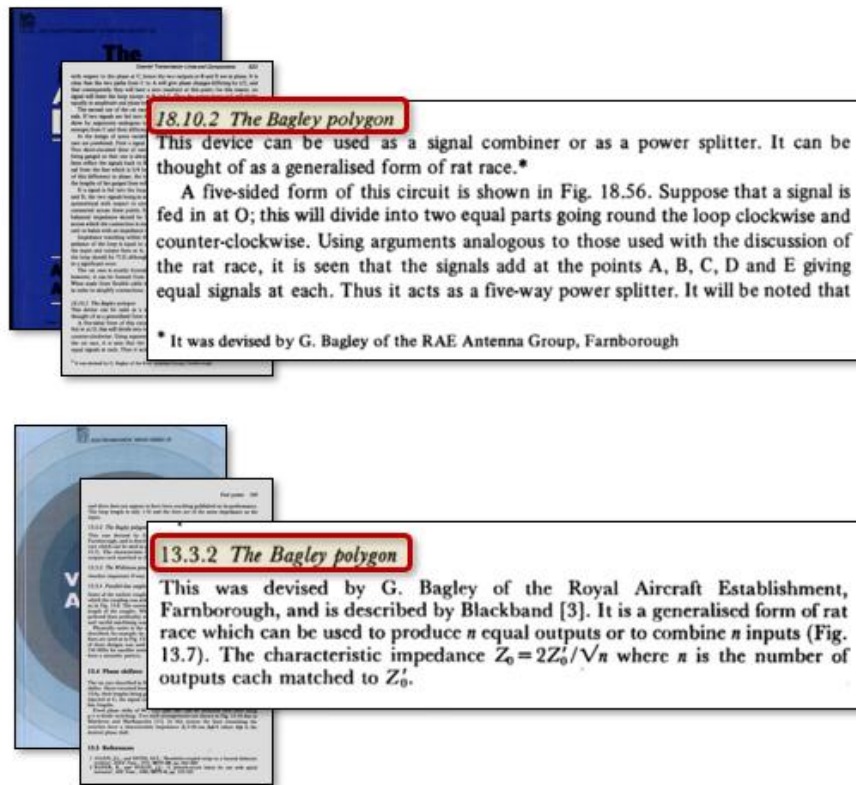

Image of Geoffrey Bagley’s 1952 paper on heterodyne interference. See G.C. Bagley, *Reducing Heterodyne Interference: A Survey Of The Problems Of Heterodyne Interference, With Particular Reference To Single-Sideband Operation*, R.S.G.B. BULLETIN VOL. 28 NO. 6 at 239 (December 1952).

33. Geoffrey Bagley’s work in wireless communication systems would lead to the development of the Bagley Polygon – an antenna developed to receive wireless communications while minimizing interference. In the following decades, the Bagley Polygon would be widely cited in research on wireless communications.<sup>18</sup> The following image shows two of the many

<sup>18</sup> See e.g., David Senior Elles and Yong-Kyu Yoon, *Compact Dual Band Three Way Bagley Polygon Power Divider Using Composite Right/Left Handed (CRLH) Transmission Lines*, 2009 IEEE MTT-S INTERNATIONAL MICROWAVE SYMPOSIUM DIGEST (2009); Iwata Sakagama, et al., *Compact Multi-Way Power Dividers Similar To The Bagley Polygon*, 2007 IEEE/MTT-S INTERNATIONAL MICROWAVE SYMPOSIUM (2007); Khair Ayman Al Shamaileh, et al., *Design Of N-Way Power Divider Similar To The Bagley Polygon Divider With An Even Number Of Output Ports*, PROGRESS IN ELECTROMAGNETICS RESEARCH 20 (2011); Abdullah Mazen Qaroot, et al., *Design And Analysis Of Dual-Frequency Modified 3-Way Bagley Power Dividers*, PROGRESS IN ELECTROMAGNETICS RESEARCH 20 (2011); Youngchul Yoon and Young Kim, *Bagley Power Divider With Uniform Transmission Lines For Arbitrary Power Ratio And Terminated In Different Impedances*, PROGRESS IN ELECTROMAGNETICS RESEARCH 77 (2017); Jiuchao li, et al., *A Novel Multi-Way Power Divider Design with Enhanced Spurious Suppression*, APPLIED COMPUTATIONAL ELECTROMAGNETICS SOCIETY JOURNAL 29.9 (2014);

books that reference the Bagley Polygon used in wireless communications systems.



R.A. Burberry, VHF AND UHF ANTENNAS at 249 (1992) (emphasis added); A.W. Rudge et al, THE HANDBOOK OF ANTENNA DESIGN VOLUME 2 at 923 (1983) (emphasis added).

### **THE INVENTIONS DISCLOSED IN THE '421 PATENT REFLECT RSRE'S HISTORY OF GROUNDBREAKING WORK**

34. The inventions taught in the '421 patent were developed at the Royal Signals and Radar Establishment in Malvern, Worcestershire in the United Kingdom. The Royal Signals and Radar Establishment was formed in 1970's through a merger of the United Kingdom's research laboratories including the Royal Radar Establishment ("RRE") and the Services Electronic

---

Roberto Gómez-García and Manuel Sánchez-Renedo, *Application Of Generalized Bagley-Polygon Four-Port Power Dividers To Designing Microwave Dual-Band Bandpass Planar Filters*, IEEE MTT-S INTERNATIONAL MICROWAVE SYMPOSIUM (2010); R.A. Burberry, VHF AND UHF ANTENNAS at 249 (1992) ("This was devised by G. Bagley of the Royal Aircraft Establishment, Farnborough."); A.W. Rudge, et al., THE HANDBOOK OF ANTENNA DESIGN VOLUME 2 at 923 (1983) ("It was devised by G. Bagley of the RAE Antenna Group, Farnborough."); and Sorin Voinigescu, HIGH-FREQUENCY INTEGRATED CIRCUITS at 426 (2013).

Research Laboratory (“SERL”).

35. Contemporaneous to Geoffrey Bagley’s work on wireless communication systems, researchers at the RSRE developed pioneering systems for thermal imaging. See Nic Fleming, *The Man Who Makes You See The Invisible*, BBC WEBSITE, (June 14, 2017), available at: <https://www.bbc.com/future/article/20170614-thermal-imaging-reveals-the-hidden-heat-lost-from-your-home> (“The first systems that generated images based on reflected light from the Moon, stars and sky were developed during the 1960s. British scientists played a leading role in the development of modern thermal imaging technologies, mostly those working at the Royal Radar Establishment (RRE) in Worcestershire, where Harper started as a student apprentice in 1967.”).

36. In addition, the RSRE was one of the early developers of internet communication systems. In 1976, the RSRE was one of the first facilities to experiment with electronic messaging in what would later be called e-mail. Cade Metz, *How the Queen of England Beat Everyone To The Internet*, WIRE MAGAZINE (December 25, 2012) (“It was revolution in digital communication. But to the Queen, it was old hat. She could even say that the first message she sent across the ARPANET in 1976 wasn’t without some real hacker cred. The Royal Signals and Radar Establishment has developed a programming language called Coral 66 – it’s also mentioned on the wall, just to her left – and this was the subject of her missive.”).

37. Further illustrating the novel work conducted at the RSRE is the RSRE’s role in the initial conception of solid-state integrated circuits. In a 1952 paper, G.W.A. Dummer of the RSRE laid out the genesis of a solid-state integrated circuit. See *Solid Circuits: Glimpses into The Future at Malvern Components Symposium*, WIRELESS WORLD at 516 (November 1957) (“At the moment the solid circuit is little more than an idea. It is being investigated by the Royal Radar Establishment at Malvern . . . A hypothetical example, described by G.W.A. Dummer of R.R.E.

and displayed as a model in the Symposium exhibition, was a transistor flip-flop with two emitter-follower outputs.”); *Mike Green, Dummer's Vision of Solid Circuits at the UK Royal Radar Establishment*, IEEE ANNALS OF THE HISTORY OF COMPUTING 35 at 56 (2013) (“Geoffrey W.A. Dummer of the British Royal Radar Establishment (RRE) described his idea of semiconductor “solid circuits” at a conference in Washington, DC in 1952.”); and P.R. Morris, *A Review of UK Government Involvement in the Field of Semiconductor Technology Within the Research Establishments*, FACETS: NEW PERSPECTIVES ON THE HISTORY OF SEMICONDUCTORS at 279 (1997) (“The leading government research and development establishment involved in semiconductor work has been the Royal Signals and Radar Establishment (RSRE), based at Malvern, Worcestershire.”).



G.W.A. Dummer, *Electronic Components in Great Britain*, SYMPOSIUM ON PROGRESS IN QUALITY ELECTRONIC COMPONENTS IRE, WASHINGTON D.C. (May 1952) (emphasis added) (“With the advent of the transistor and the work on semi-conductors generally, it now seems possible to envisage electronic equipment in a solid block with no connecting wires. The block may consist of layers of insulating, conducting, rectifying and amplifying materials, the electronic functions being connected directly by cutting out areas of the various layers.”).

38. The first touchscreen interface was also developed by Geoffrey Bagley’s contemporaries at RSRE. The development of these concomitant fundamental computer

technologies informed Geoffrey Bagley's work on wireless communications, including the inventions disclosed in the '421 patent.

The first device that we would recognize as a touchscreen today is believed to have been invented by Eric Arthur Johnson, an engineer at England's Royal Radar Establishment, in 1965. And it was created to improve air traffic control.

In Johnson's day, whenever a pilot called in an update to his or her flight plan, an air traffic controller had to type a five-to seven-character call sign into a teleprinter in order to enter it on an electronic data display. That extra step was time-consuming and allowed for user error.

Brian Merchant, *THE ONE DEVICE: THE SECRET HISTORY OF THE IPHONE* at 270 (2017) (emphasis added) ("The first device that we would recognize as a touchscreen today is believed to be invented by Eric Arthur Johnson, an engineer at England's Royal Radar Establishment, in 1965.").

**THE '421 PATENT IS DIRECTED TO SOLVING LIMITATIONS IN  
CARRIER SIGNAL IDENTIFICATION**

39. U.S. Patent No. 7,835,421 (the "421 patent") entitled, *Electric Detector Circuit*, was filed on January 22, 1990, and claims priority to January 4, 1983. The '421 patent expires November 16, 2027. Castlemorton is the owner by assignment of all right, title, and interest in the '421 patent. A true and correct copy of the '421 patent is attached hereto as Exhibit A.

40. The '421 patent discloses a novel method and system for detecting the carrier signal frequency in wireless data signal communications.

41. The '421 patent teaches the detection of the carrier frequency direct-sequence spread spectrum signals ("DSSS"). DSSS is a spread spectrum technique initially developed for military wireless communications. The essential idea is to spread the wireless signal over a wider bandwidth to make jamming and interception more difficult.

42. Spread spectrum was invented by Austrian-born actress Hedy Lamarr. Before fleeing Nazi Germany, she was married to an Austrian arms merchant and learned that existing narrowband radio communications were subject to jamming. Hedy Lamarr conceived of the idea

of using a complex but predetermined hopping pattern to move the frequency of a control signal around. “Even if short bursts on a single frequency could be jammed, they would move around quickly enough to prevent total blockage.” Matthew Gast, 802.11 WIRELESS NETWORKS: THE DEFINITIVE GUIDE at 237 (2005). In 1942, Hedy Lamarr and her husband, composer George Antheil, were granted a patent to the use of frequency hopping whereby a signal would be spread across multiple frequencies by hopping from one frequency to another.

43. The two primary forms of spread spectrum techniques are: frequency-hopping spread spectrum and direct-sequence spread spectrum. Frequency hopping spread spectrum is a form of spread spectrum in which the signal is broadcast over a seemingly random series of radio frequencies, hopping from frequency to frequency.

44. The ‘421 patent is directed at improving the functioning of DSSS, a more recent type of spread spectrum. In DSSS, each bit of an original signal is represented by multiple bits in the transmitting signal, using a spread code. The spreading code spreads the signal across a wider frequency band in direct proportion to the number of bits used. Therefore, a 10-bit spreading code spreads the signal across a frequency band that is 10 times greater than a 1-bit spreading code. One common way of implementing DSSS is to combine the original signal with the spreading code bit stream using an exclusive-OR (“XOR”) operation. Typically, the XOR obeys the following rules:

$$0 \otimes 0 = 0 \quad 0 \otimes 1 = 1 \quad 1 \otimes 0 = 1 \quad 1 \otimes 1 = 0$$

To see how a signal is then spread, assume the original signal contains the following bits 110100 and the spreading code is 001010011001110101. The resulting transmitted signal will be spread across a wider frequency band.

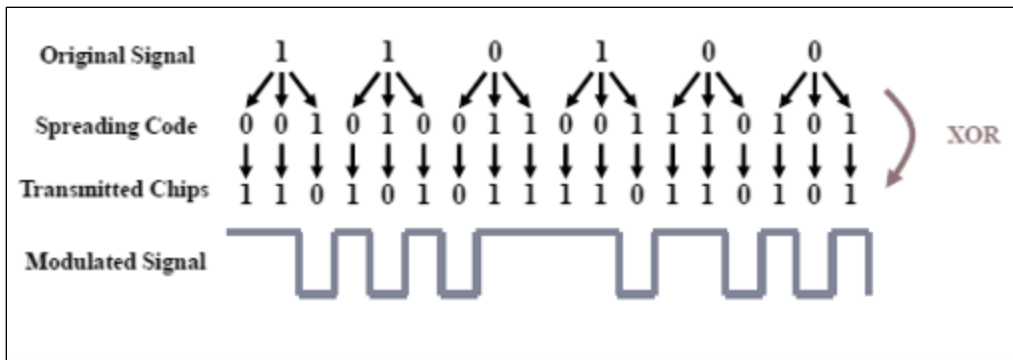

Example of Direct Sequence Spread Spectrum (showing the original signal, spreadcode and modulated signal).

45. The receiver of the modulated DSSS signal then demodulates the signal by performing the inverse operation, the smeared-out signal is reconstituted as a narrow-band signal, and, more importantly, any narrow-band noise is smeared out so the signal shines through clearly.

46. At the time the '421 patent inventions were conceived, existing systems had difficulty identifying a received carrier signal from undesired transmission (*e.g.*, noise). For example, U.S. Patent No. 4,601,047, entitled *Code Division Multiplexer Using Direct Sequence Spread Spectrum Signal Processing*, which was cited in the prosecution of the '421 patent, identified the difficulty that existing prior art systems had in identifying the carrier signal from surrounding "undesired transmissions."

Because the correlation method of the invention involves a subtraction of a code sequence having an unassigned code sequence shift, all undesired transmission components (identified by the subscript "r") in the output VB (T) are perfectly rejected, whereas in the prior art receiver, the output VA (T) involves contributions of the undesired transmissions (having the subscript "j") as well as the desired transmissions (subscript "r").

U.S. Patent No. 4,601,047, col. 10:20-27 (emphasis added).<sup>19</sup>

47. Existing systems for receiving direct sequence spread spectrum signals at the time the '421 patent inventions were developed had further limitations including difficulty in

<sup>19</sup> U.S. Patent No. 4,601,047 is assigned to Sangamo Weston Inc. and was filed on March 23, 1984.

distinguishing a carrier signal from signal noise as receivers of a modulated carrier signal would attempt to lock onto the noise. U.S. Patent No. 4,567,588, entitled, *Synchronization System For Use In Direct Sequence Spread Spectrum Signal Receiver*, which was cited in the prosecution of the '421 patent, describes this problem in identifying a carrier signal from noise.

As another problem, a direct sequence spread spectrum receiver does not readily distinguish between a signal and noise, particularly since the incoming signal is a data modulated carrier that is spread by a pseudo-noise sequence. The receiver will thus tend to attempt to lock onto noise in the absence of a signal.

U.S. Patent No. 4,567,588, col. 4:43-48 (emphasis added).<sup>20</sup>

48. Existing systems also had difficulty correlating the received signal so that a carrier frequency could be identified. For example, U.S. Patent No. 4,561,089, entitled *Correlation Detectors For Use In Direct Sequence Spread Spectrum Signal Receiver*, which was cited in the prosecution of the '421 patent, identified the difficulty that existing systems had in identifying a carrier signal through correlation.

[T]he degree of correlation between the predetermined transmitter and the receiver is determined by comparing the output of several correlation detectors having reference signals that are displaced in time from each other. An error signal is generated and applied to control receiver timing to perfectly align the code sequence shift of the receiver reference sequence to the code sequence shift of the predetermined transmitter. A large number of adjustments of the correlation detector components, however, are required. . . . This creates a significant problem, both during initial calibration and during maintenance.

U.S. Patent No. 4,561,089, col. 4:11-31 (emphasis added).<sup>21</sup>

49. The '421 patent is directed at solving a need that was identified in patents that were contemporaneous to the inventions disclosed in the '421 patent. Specifically, U.S. Patent No. 4,538,281, entitled *Adaptive Acquisition of Multiple Access Codes*, which was cited in the

<sup>20</sup> U.S. Patent No. 4,567,588 is assigned to Sangamo Weston, Inc. and was filed on March 23, 1984.

<sup>21</sup> U.S. Patent No. 4,561,089 is assigned to Sangamo Weston, Inc. and was filed on March 23, 1984.



prosecution of the '421 patent, describes the “substantial need” for systems that “enable the detection and acquisition of the coded signal.”

There is therefore a continuing and substantial need for systems and techniques which enable the detection and acquisition of the coded signal in multiple access communication systems using code division multiplexing which will improve strong signal performance without significant degrading of the weak signal performance.

U.S. Patent No. 4,538,281, col. 2:50-56 (emphasis added).<sup>22</sup>

50. The '421 patent is directed at a problem in the prior art wherein the carrier signal is difficult to identify unless the number of transmissions in the band was kept “low.” For example, U.S. Patent No. 4,532,635, entitled *System And Method Employing Two Hop Spread Spectrum Signal Transmissions Between Small Earth Stations Via A Satellite And A Large Earth Station And Structure And Method For Synchronizing Such Transmission*, which was cited in the prosecution of the '421 patent, describes noise as making “error probability high” unless the number of transmissions is kept “low.”

In conventional spread spectrum the waveforms are not orthogonal to each other and a station receiving a desired spread spectrum transmission will also see many other spread spectrum transmissions. While the other spread spectrum transmissions will appear as noise such noise forms a background which makes error probability high unless the number of simultaneous users in the band are kept reasonably low.

U.S. Patent No. 4,532,635, col. 3:44-51 (emphasis added).<sup>23</sup>

51. Existing systems at the time the inventions disclosed in the '421 patent were developed were unable to “readily distinguish between signal and noise.” U.S. Patent No. 4,979,183, entitled *Transceiver Employing Direct Sequence Spread Spectrum Techniques*, which was filed several years after the '421 patent, described a drawback of existing systems for

---

<sup>22</sup> U.S. Patent No. 4,538,281 is assigned to Boeing Co. and was filed on May 6, 1982.

<sup>23</sup> U.S. Patent No. 4,532,635 is assigned to RCA Corp. and L3 Communications Corp. and was filed on August 19, 1983.

identifying a carrier signal in spread spectrum communication techniques, which was the difficulty in “synchronization between the transmitter and receiver.”

One of the drawbacks, however, in using spread spectrum communication techniques is that they often require elaborate, complex and expensive circuitry. Certain types of spread spectrum systems, such as direct sequence spread spectrum, also suffer from prohibitively long acquisition and decoding times. Since a direct sequence spread spectrum receiver does not readily distinguish between signal and noise, and, in particular, since the incoming signal is a data modulated carrier that is spread by a pseudonoise sequence, synchronization between the transmitter and receiver is often troublesome.

U.S. Patent No. 4,979,183, col. 2:23-34 (emphasis added).<sup>24</sup>

52. The issue of “false correlations” was a significant limitation in existing systems at the time the inventions disclosed in the ‘421 patent were conceived. For example, U.S. Patent No. 5,022,046, entitled *Narrowband/Wideband Packet Data Communication System*, which was filed roughly five years after the ‘421 patent, describes existing systems as having difficulty in synchronizing the receiver of a spread spectrum communication.

One of the more difficult problems in spread-spectrum communications is initial receiver acquisition of the signature sequence. The problem is exacerbated in a packet system, since receiver synchronization must be reaccomplished at the beginning of each packet. False correlations with a time-shifted version of its own spreading sequence or with a portion of another user's sequence during packet transmission could cause loss of the packet.

U.S. Patent No. 5,022,046, col. 3:40-49 (emphasis added).<sup>25</sup>

53. Overcoming limitations in existing direct sequence spread spectrum devices for identifying a carrier signal and synchronizing the receiver and transmitter were described in patents

---

<sup>24</sup> U.S. Patent No. 4,979,183 is assigned to Echelon Systems Corporation and was filed on March 23, 1989.

<sup>25</sup> U.S. Patent No. 5,022,046 is assigned to United States Air Force and was filed on April 14, 1989; *see also* U.S. Patent No. 4,774,715, col. 1:42-49 (“Basically, it is difficult to synchronize a locally generated PN decoding signal with a received signal as no significant indication of the degree of non-synchronization between such signals is available until the phase difference between the signals is minimal. The ability to reject multiple reflections of a signal consequently creates difficulties in synchronizing to a desired signal.”).

from shortly after the priority date of the '421 patent as being a “significant design challenge” and “complex.” For example, in U.S. Patent No. 5,365,550, entitled *Initial Synchronization And Tracking Circuits For Spread Spectrum Receivers*, the limitations in existing prior art is discussed.

Direct sequence digital spread spectrum receivers present a significant design challenge in synchronizing the receiver clock with the transmitter clock, particularly under severe multipath and interference conditions. The sliding correlator technique of acquiring initial synchronization known in the prior art is typically used due to its inherently simple, yet predictable nature. Once synchronization is acquired, a Tau-dither technique known in the prior art is typically used to track the transmitter clock. However, multipath interference tends to result in rapid changing of perceived transmitter code clock rate, often resulting in a loss of synchronization. Attempts to improve the performance of these techniques have been quite complex and expensive.

U.S. Patent No. 5,365,550, col. 1:39-53 (emphasis added).<sup>26</sup>

54. At the time the '421 patent was developed, acquisition times for a carrier signal frequency were an impediment to efficient wireless communication systems. U.S. Patent Nos. 4,912,722, which was filed shortly after the '421 patent, describes the difficulties encountered by existing systems as they relate to acquisition times for a identifying a carrier signal.

The problem remaining in the prior art is to provide a technique for spread spectrum transmissions which could eliminate the need for the expensive pseudo-noise code acquisition and tracking systems and thereby provide a low-cost, compact design spread spectrum transmitter/receiver. Present pseudo noise code acquisition systems also have long acquisition times and a further problem would be to provide a technique which can be useful in conjunction with existing code acquisition systems to provide a composite system with low acquisition times.

U.S. Patent No. 4,912,722, col. 2:10-20 (emphasis added).<sup>27</sup>

---

<sup>26</sup> U.S. Patent No. 5,365,550 is assigned to Westinghouse Air Brake Co. and was filed on July 18, 1991; *see also* U.S. Patent No. 5,428,647, col. 2:28-35 (“Therefore, a need exists for a synchronization technique which is simple enough to be inexpensively built for use by low tier communication unit while at the same time providing rapid synchronization for use by a communication unit operating in the high tier communication system. The high tier communication system needs rapid synchronization.”).

<sup>27</sup> U.S. Patent No. 4,912,722 is assigned to Nokia Corporation and was filed on September 20, 1988; *see also* U.S. Patent No. 5,754,585, col. 2:20-26 (“Moreover, locking onto the received frequency and phase can take an unacceptably large amount of time, particularly in systems where time is of the essence, such as in certain time division multiple access (TDMA) systems

55. The initial developers of the 802.11 set of wireless standards identified the need to address “delay” in identifying a carrier signal as one of the primary requirements for the 802.11 technology. The below excerpt from the 1992 minutes of the IEEE 802.11 MAC Ad-Hoc Committee shows the importance of this requirement. The first 802.11 standard would not be released for a further 6 years. Yet, even at this early date, the need to correlate DSSS signals with substantially zero relative time delay was a paramount concern. Unknown to the developers of the 802.11 standard, a technology to quickly detect a carrier frequency of a DSSS signal had already been invented. However, this technology (the technology claimed in the ‘421 patent) was subject to a national security order that prevented its disclosure.

<p><b>IEEE P802.11 PAR</b>  <b>IEEE P802.11 Requirements</b>  <b>Summary is that there are two basic classes of service required:</b>  <b>Asynchronous: low avg transfer delay (as low as 2 msec transfer delay)</b>  <b>Synchronous: low transfer delay variance (MSDU jitter) &lt; - 10%</b>  <b>IEEE 802.2 LLC support</b>  <b>Coverage area &lt; 100m or up to 1km</b>  <b>Structure service to match the expected traffic</b>  <b>Async service for bursty traffic</b>  <b>Sync service for "realtime" traffic</b></p>
---

*Tentative Minutes of the IEEE 802.11 MAC Ad-Hoc Committee*, DOC:IEEE P802.1/92-21 at 2 (January 14, 1992) (emphasis added).

**COUNT I**  
**INFRINGEMENT OF U.S. PATENT NO. 7,835,421**

56. Castlemorton references and incorporates by reference the preceding paragraphs of this Complaint as if fully set forth herein.

57. Altice designs, makes, uses, sells, and/or offers for sale in the United States products and/or services for detecting the carrier frequency of a DSSS signal.

---

in which only a relatively brief time slot is allocated for periodic communication between a transmitter and receiver.”).

58. Altice designs, makes, sells, offers to sell, imports, and/or uses products and/or services for detecting a carrier frequency of a direct sequence spread spectrum signal in compliance with the IEEE 802.11b and/or IEEE 802.11g wireless standard including at least the following products and services: Altice One (Model No. DGCI384), Altice One Mini (Model Nos. DCIWA384 and DCIWA384-V2), Altice FiberGateway (Model No. GR240BG), Altice Amplify (Model No. SBDV01), SuddenLink Business Managed WiFi, SuddenLink Business WiFi@Work, and Altice service plans that include devices and services that comply with the IEEE 802.11b and/or IEEE 802.11g standard (e.g., TG2482 and CGNM-2250) (collectively the, “Altice ‘421 Product(s)”).

59. The Altice ‘421 Products detect a carrier frequency in a direct sequence spread spectrum signal in compliance with the IEEE 802.11b or IEEE 802.11g standards. For example, documentation for the Altice FiberGateway states that it complies with the IEEE 802.11b and IEEE 802.11g standards.

### 2.11.2 Operational Description

The FiberGateway supports Wi-Fi, with Wi-Fi interfaces operating in the 2.4GHz and 5GHz frequencies

The FiberGateway complies with the following standards:

- IEEE 802.11a (5GHz, up to 54 Mbps)
- IEEE 802.11b (2.4GHz, up to 11 Mbps)
- IEEE 802.11g (2.4GHz, up to 54 Mbps)
- IEEE 802.11n (2.4GHz and 5 GHz, up to 600 Mbps)
- IEEE 802.11ac (5GHz, up to 1733 Mbps)

*Altice FiberGateway GR240BG User Manual, ALTICE DOCUMENTATION VERSION 4.1-6 at 27 (2018);*

60. The Altice ‘421 Products enable communication over the 2.4 GHz band using signal modulation and demodulation that is compliant with the IEEE 802.11b and IEEE 802.11g standards. The following excerpt from a submission to the United States Federal Communication

Commission (“FCC”) explains how the Altice One complies with the IEEE 802.11b and 802.11g standards.

Equipment information:			
Type:	WIFI		
Frequency band:	2400MHz-2483.5MHz		
Standard:	<input checked="" type="checkbox"/> 802.11b	<input checked="" type="checkbox"/> 802.11g	<input checked="" type="checkbox"/> 802.11n HT20 <input checked="" type="checkbox"/> 802.11n HT40
Spectrum Modulation:	<input checked="" type="checkbox"/> DSSS		<input checked="" type="checkbox"/> OFDM
Number of Channel:	11		
Spacing channel:	5MHz		
Channel bandwidth:	<input checked="" type="checkbox"/> 20MHz	<input checked="" type="checkbox"/> 40MHz	
Antenna Type:	<input checked="" type="checkbox"/> Integral	<input type="checkbox"/> External	<input type="checkbox"/> Dedicated
Antenna connector:	<input checked="" type="checkbox"/> Yes	<input type="checkbox"/> No	<input type="checkbox"/> Temporary for test

*Altice One FCC ID No. VW3DGC1384, FCC TEST REPORT RE WiFi 2.4 GHz No. 145064-694081C at 7 (January 19., 2017) (emphasis added).*

61. The Altice ‘421 Products enable communication over a frequency band with a range of 2400MHz to 2483.5MHz that is complaint with the IEEE 802.11b and IEEE 802.11g standards. Further documents submitted to the FCC establish that the Alice ‘421 Products including the Altice Amplify product support DSSS spectrum modulation and the use of 11 channels to send and receive DSSS signals.

Equipment Information:			
Type:	WiFi		
Frequency band:	2400MHz-2483.5MHz		
Standard:	<input checked="" type="checkbox"/> 802.11b	<input checked="" type="checkbox"/> 802.11g	<input checked="" type="checkbox"/> 802.11n HT20 <input checked="" type="checkbox"/> 802.11n HT40
Spectrum Modulation:	<input checked="" type="checkbox"/> DSSS		<input checked="" type="checkbox"/> OFDM
Number of Channel:	11		
Spacing channel:	5MHz		
Channel bandwidth:	<input checked="" type="checkbox"/> 20MHz	<input checked="" type="checkbox"/> 40MHz	

*ALTICE AMPLIFY FCC ID VW3SBDV01*, FCC TEST REPORT RE WiFi 2.4GHZ No. 157205-726501-C AT 6 (NOVEMBER 19, 2018) (emphasis added).

62. Each of the accused devices complies with the IEEE 802.11b and/or IEEE 802.11g standards: Altice One (Model No. DGCI384),<sup>28</sup> Altice One Mini (Model Nos. DCIWA384 and DCIWA384-V2),<sup>29</sup> Altice FiberGateway (Model No. GR240BG),<sup>30</sup> Altice Amplify (Model No. SBDV01),<sup>31</sup> SuddenLink Business Managed WiFi,<sup>32</sup> and SuddenLink Business WiFi@Work.<sup>33</sup>

<sup>28</sup> *Altice One Guide*, SUDDENLINK DOCUMENTATION (2018); *Altice One FCC ID No. VW3DGCI384*, FCC TEST REPORT RE WiFi 2.4 GHZ No. 145064-694081C at 7 (January 19., 2017).

<sup>29</sup> *Altice One Mini FCC ID No. VWDCIWA384-V2*, FCC TEST REPORT RE WiFi 2.4GHZ No. 155636-721608-C at 7 (September 13, 2018); ALTICE ONE MINI USER MANUAL DCIWA384-UHD (2018).

<sup>30</sup> *Altice FiberGateway GR240BG User Manual*, ALTICE DOCUMENTATION VERSION 4.1-6 at 27 (2018); *Altice FiberGateway FCC ID No. 2ACJF-FGW-GR240BG*, FCC TEST REPORT RE WiFi 2.4 GHZ No. 103224477MPK-002A at 5 (October 18, 2017).

<sup>31</sup> *Altice Amplify WiFi Alliance Certificate ID WFA81163*, SBDV01 CERTIFICATION (June 19, 2019); *Altice Amplify FCC ID VW3SBDV01*, FCC TEST REPORT RE WiFi 2.4GHZ No. 157205-726501-C at 6 (November 19, 2018).

<sup>32</sup> *SuddenLink Business Managed WiFi – Webpage*, SUDDENLINK BUSINESS WEBSITE (last visited January 2020), available at: <https://www.suddenlinkbusiness.com/managed-services/wifi>.

<sup>33</sup> *Suddenlink – Using Enhanced WiFi@Work*, SUDDENLINK CUSTOMER GUIDE (September 21, 2015); *SuddenLink Enhanced WiFi@Work User Guide*, SUDDENLINK USER GUIDE (2016).

63. One or more of the Altice ‘421 Products contain antenna(s) that perform the step of receiving a direct sequence spread spectrum signal. For example, the Altice FiberGateway device contains 2.4GHz antennas (identified in the following image) that are used in the sending and receiving of direct sequence spread spectrum signals in compliance with the 802.11b standard.

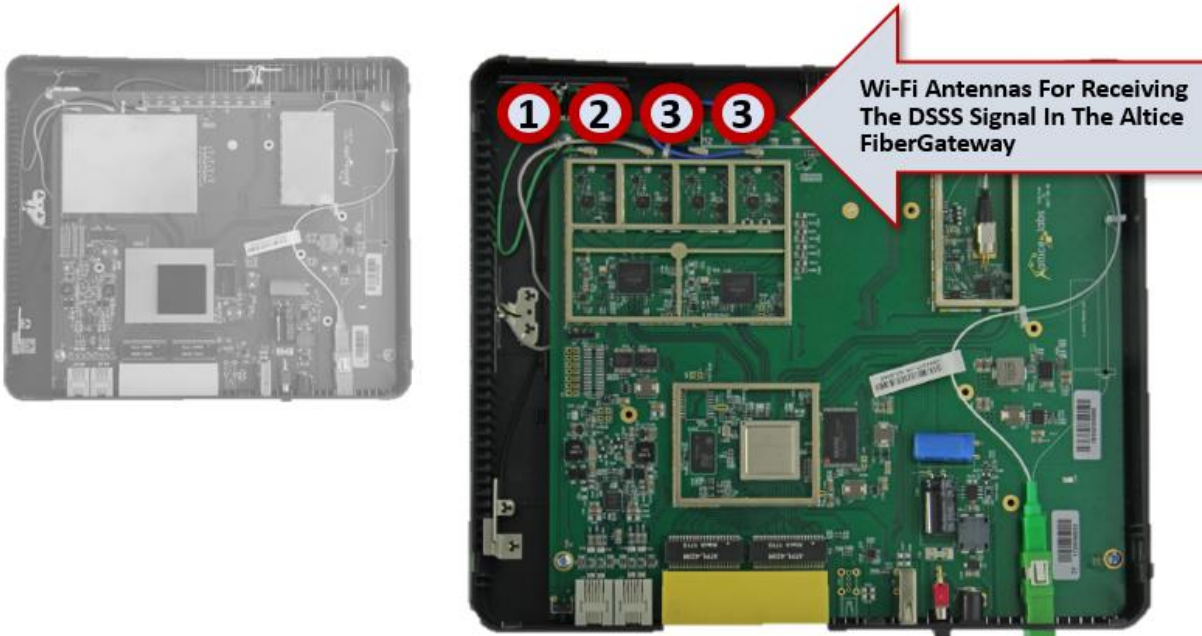

*Altice FiberGateway GR240BG*, DEVICE TEARDOWN IMAGE (annotation added) (showing the antennas in the device).

64. The Altice ‘421 Products enable the transmission and receipt of signals in up to 11 channels in the 2.4GHz frequency when operating in 802.11b mode. For example, filings with the United States Federal Communications Commission (“FCC”) for the Altice FiberGateway device describe that data is transmitted in 11 channels in the 2.4GHz frequency for 802.11b.



 <p style="text-align: center;"><b>TEST REPORT</b></p> <p>Report Number: 103224477MPK-002A Project Number: G18224477 October 18, 2017</p> <p>Testing performed on the <b>FIBERGATEWAY</b> Model: GR240BG FCC ID: 2ACJF-FGW-GR240BG</p> <p>in FCC Part 15 Subpart C (15.247) FCC Part 15, Subpart B</p> <p>For Altice Labs, SA</p> <p>Test Performed by: Intertek 1365 Adams Court Mesa, PA, CA 94025 USA</p> <p>Tested At: Altice Eva Day, Test 1010-108-01</p> <p>Prepared by: <i>Mark Li</i> Reviewed by: <i>Kathryn Vroman</i></p> <p><small>This report is for the exclusive use of the client and is provided pursuant to the agreement. Intertek's responsibility and liability are limited to the terms and conditions of the agreement. No party, other than the Client, is authorized to copy or distribute this report and the only use is for the Client's internal use. No part of this report may be reproduced, stored in a retrieval system, or transmitted in any form or by any means, electronic, mechanical, photocopying, recording, or by any information storage and retrieval system, without the prior written permission of Intertek. This report is the property of Intertek and shall remain the property of Intertek. This report is not to be used for any other purpose without the prior written permission of Intertek.</small></p> <p>EMC Report for Altice Labs on the GR240BG File: 103224477MPK-002A Page 1 of 194</p>	
<b>Applicant</b>	Altice Labs, SA
<b>Model Number</b>	GR240BG
<b>FCC Identifier</b>	2ACJF-FGW-GR240BG
<b>Modulation Technique</b>	DSSS (CCK), OFDM (BPSK, QPSK, 16QAM, 64QAM)
<b>Rated RF Output</b>	802.11b: 29.98 dBm 802.11g: 29.19 dBm 802.11n 20MHz: 28.90 dBm 802.11n 40MHz: 28.56 dBm
<b>Frequency Range</b>	2412 – 2462 MHz, 802.11b/g/n
<b>Type of modulation</b>	BPSK, QPSK, 16QAM, 64QAM
<b>Number of Channel(s)</b>	11 for 802.11b/g/n
<b>Antenna(s) &amp; Gain</b>	Internal Antenna, calculated peak gain: 3.9dBi Ant 0 – DB1: 4.0dBi, Vertical Ant 1 – DB2: 3.6dBi, Horizontal Ant 2 – DB3: 2.4dBi, Horizontal Ant 3 – DB4: 3.8dBi, Vertical

*Altice FiberGateway FCC ID No. 2ACJF-FGW-GR240BG, FCC TEST REPORT RE WiFi 2.4 GHZ NO. 103224477MPK-002A at 5 (October 18, 2017) (emphasis added).*

65. The Altice ‘421 Products use complementary code keying to modulate and demodulate data. A direct spread spectrum signal transmitted at either 5.5 Mbit/s or 11 Mbit/s is received by the Altice ‘421 Products.

66. The Altice ‘421 Products comprise a spectrum analyzer for detecting a carrier frequency from a full geographic-specific set of available carrier frequencies.

67. The Altice ‘421 Products perform the step of sending and receiving signal data in channels using complementary code keying (“CCK”), differential quadrature phase shift keying (“DQPSK”), and/or differential binary phase-shift-keying (“DBSK”) for direct sequence spread spectrum. The following excerpt from a submission to the FCC for the Altice One device identifies the use of CCK, DBPSK, and DQPSK modulation types when transmitting and receiving direct sequence spread spectrum signals.

CHANNEL PLAN	
802.11b / 802.11g / 802.11n HT20	
Channel	Frequency (MHz)
Cmin: 1	2412
2	2417
3	2422
4	2427
5	2432
Cmid: 6	2437
7	2442
8	2447
9	2452
10	2457
Cmax: 11	2462

DATA RATE		
802.11b		
Data Rate (Mbps)	Modulation Type	Modulation Worst Case
1	DBPSK	<input checked="" type="checkbox"/>
2	DQPSK	<input type="checkbox"/>
5,5	DQPSK	<input type="checkbox"/>
11	CCK	<input type="checkbox"/>

Altice One FCC ID No. VW3DGC1384, FCC TEST REPORT RE WiFi 2.4 GHz No. 145064-694081C at 8, 9 (January 19., 2017) (annotation added).

68. The Altice ‘421 Products enable the identification of a carrier wave from a spectral range between 2.400–2.4835 GHz.

69. The Altice ‘421 Products perform the step of subtracting the spread spectrum signal from a signal with a higher frequency than the DSSS signal spectrum. For example, the Altice ‘421 Products contain functionality for a processing gain of at least 10 dB. This is performed by the Altice ‘421 Products by chipping the baseband signal at 11 MHz with an 11-chip code.

70. The Altice One Mini device enables demodulating DSSS signals that are modulated using DBPSK, DQPSK, and CCK modulation. The from excerpt from a report submitted to the FCC for equipment authorization identifies the Altice One Mini device as performing demodulation of signals using DBPSK, DQPSK, and CCK modulation for IEEE 802.11b complaint signals.

TEST REPORT		DATA RATE	
Subject: Radio spectrum tests according to 47 CFR Part 15 Issued to: SAGEMCOM BROADBAND 200 Route de l'Empireur 92500 - RUEIL MALMAISON FRANCE Apparatus under test: Home router SAGEMCOM DCWAS4 UNO AR US V 20376 4997 VWDCIWA384-V2 Test date: May 25, 2018 to June 7 Test location: Forney Ave Flores & Co Composition of document: 97 pages Document issued on: September 13, 2018 Written by: Mathieu COUSIN Tests operator:		802.11b	
Data Rate (Mbps)	Modulation Type		
1	DBPSK		
2	DQPSK		
5.5	DQPSK		
11	CCK		

Altice One Mini FCC ID No. VWDCIWA384-V2, FCC Test Report re WiFi 2.4GHz No. 155636-721608-C at 9 (September 13, 2018) (annotation added).

71. The Altice '421 Products contain 2.4GHz antenna(s) that perform the step of receiving a direct sequence spread spectrum signal. For example, the Altice One Mini device contains 2.4GHz antennas that are used in the sending and receiving of direct sequence spread spectrum signals in compliance with the 802.11b standard. The following image shows the location of one of the 2.4GHz antennas in the Altice One Mini circuit board.

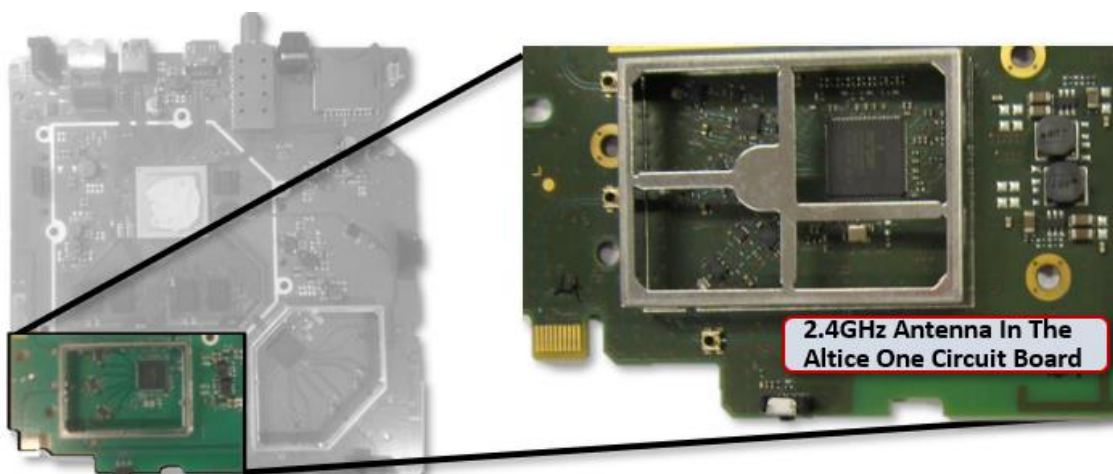

Altice One Mini 2.4GHz Antenna Location, DEVICE TEARDOWN IMAGE (annotation added).

72. The Altice '421 Products contain circuitry that perform demodulation of received DSSS signals. The following image shows the circuit board for the Altice One. The image on the left shows the Altice One circuit board with the shielding covering the wireless circuitry including the radio frequency circuitry. The image on the right shows the location of the circuitry in the Altice One device that performs at least in part the identification of a carrier signal from a DSS signal through the use of signal inversion.



*Altice One Circuit Board, ALTICE ONE DEVICE TEARDOWN IMAGE (annotation added).*

73. The Altice '421 Products contain functionality wherein the digital data is modulated by a much higher rate sequence of pseudo-noise data. This modulation process occurs in the physical medium dependent sublayer of the Altice '421 Products.

74. The Altice '421 Products correlate the inverted and non-inverted direct sequence spread spectrum signal using zero relative time delay. Specifically, the Altice '421 Products conform to the IEEE 802.11 standard which requires the transmit to receive turnaround time by less than 10  $\mu$ sec (*i.e.*, 0.00001 seconds). Further, the receive to transmit turnaround time is conducted by the Altice '421 Products in conformance with the IEEE 802.11 standard such that the turnaround time is less than or equal to 5  $\mu$ sec (*i.e.*, 0.000005 seconds).

75. The Altice ‘421 Products correlate the inverted and non-inverted signal using techniques that make the time delay functionally zero as described in the following analysis of the requirements for the 802.11 standard: Jonathan Y.C. Cheah, A PROPOSED 802.11 RADIO LAN ARCHITECTURE at 1 (January 1991) (“The speed of synchronization has also been discussed. Here, two assumptions are made. One is that under the current regulatory climate, the use of spread spectrum technique is necessary. Spread spectrum technique also presents a number of useful properties that greatly reduced the complexity in combating propagation related problems. The other assumption deals with the desire to keep the transmission half duplex. This is because of the likely spectrum constraints and the advantage of much reduced RF design complexity.”).

76. The Altice One device contains two 2.4 GHz Antennas that are used for the receiving of DSSS signals that comply with the 802.11b standard. The following teardown of the Altice One (Model No. DGCI384) shows the WiFi antennas which include two dual band antennas and a mono band 5 GHz antenna



*Altice One WiFi Antennas, ALTICE ONE TEARDOWN IMAGE (annotations added).*

77. The Altice ‘421 Products compare a spread spectrum signal to a chipped signal to detect a carrier wave. Specifically, the Altice ‘421 Products look for changes to the signal that occur across the entire frequency band. Correlation gives the received direct-sequence signal protection against interference as noise takes the form of relatively narrow pulses that, by

definition, do not produce coherent effects across the entire frequency band. Therefore, the correlation function performed by the Altice ‘421 Products spread out noise across the band, and the correlated carrier wave can be identified.

78. The Altice ‘421 Products receive DSSS signals where an original signal is multiplied by a “noise” signal prior to transmission. The noise signal is a pseudorandom sequence of 1 and -1 values, at a frequency much higher than that of the original signal. The below image from an FCC report on the Altice FiberGateway device illustrates this process. The below image shows that when the device is transmitting a signal in channel 1 of the 2412MHz frequency the signal is spread across a range of frequencies.

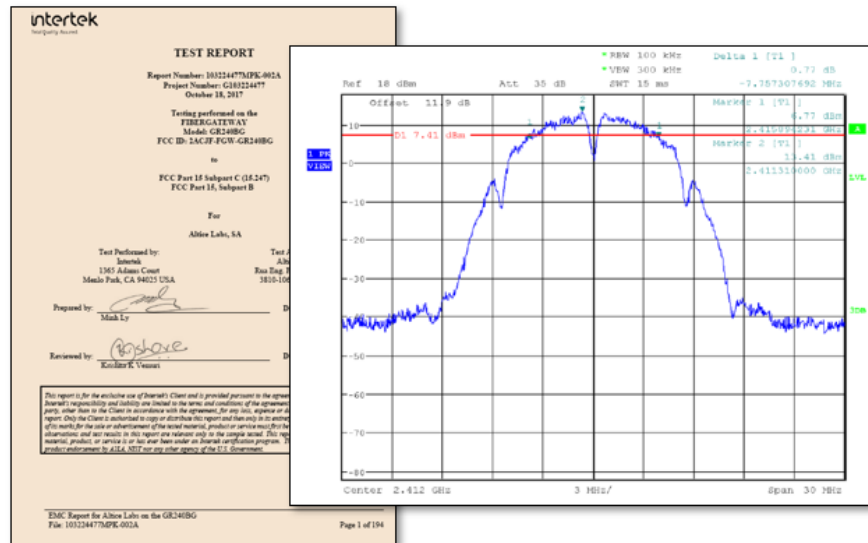

Altice FiberGateway FCC ID No. 2ACJF-FGW-GR240BG, FCC TEST REPORT RE WiFi 2.4 GHz NO. 103224477MPK-002A at 12 (October 18, 2017) (showing channel 1 of the 802.11b frequency at 2412MHz).

79. The Altice ‘421 Products contain functionality for modulating a received signal by a higher rate sequence of pseudo-noise data. The higher rate sequence of pseudo-noise data is known as the chip rate. By modulating the data using the higher rate sequence pseudo-noise data, the bandwidth frequency is increased. Each bit of the pseudo-noise sequence is a chip. The

“chips” used by the Altice ‘421 Products modulate the lower rate digital input data by a phase shift in the carrier at the chip rate. This is then superimposed on the much lower rate phase shifts caused by the input data. The Altice ‘421 Products thus are able to increase the frequency bandwidth of the signal and decrease the concentration of signal energy around the carrier. The process used by Altice ‘421 Products is shown in the below excerpt from documentation from the IEEE 802.11 Working Group for WLAN Standards.

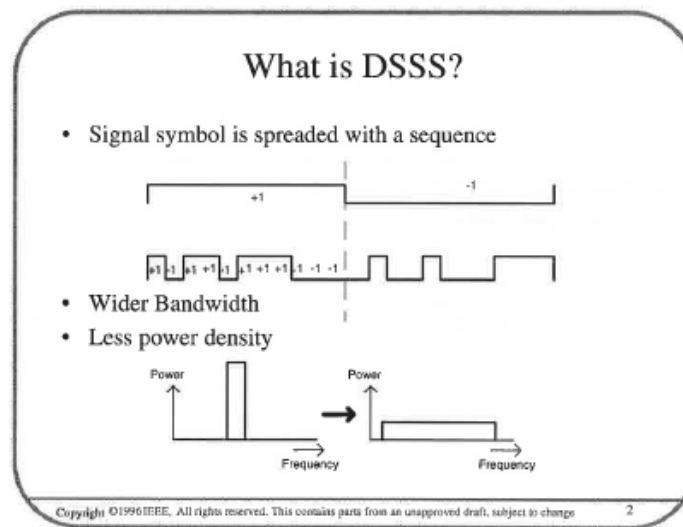

Jan Boer, *Direct Sequence Spread Spectrum Physical Layer Specification IEEE 802.11*, IEEE P802.11-96/49E at 1 (March 1996).

80. The Altice ‘421 Products identify a carrier frequency from a correlation signal. Specifically, the Altice ‘421 Products receive a spread spectrum signal and de-spread the signal by correlating it with a local replica of the pseudo noise code. Using this technique, the Altice ‘421 Products spread the narrow band interference over the bandwidth of the pseudo noise signal. After the signal is correlated with a local replica of the pseudo noise code, the carrier frequency is identified. The process used by the Altice ‘421 Products is shown in the below diagram from documentation of the IEEE 802.11 Working Group.

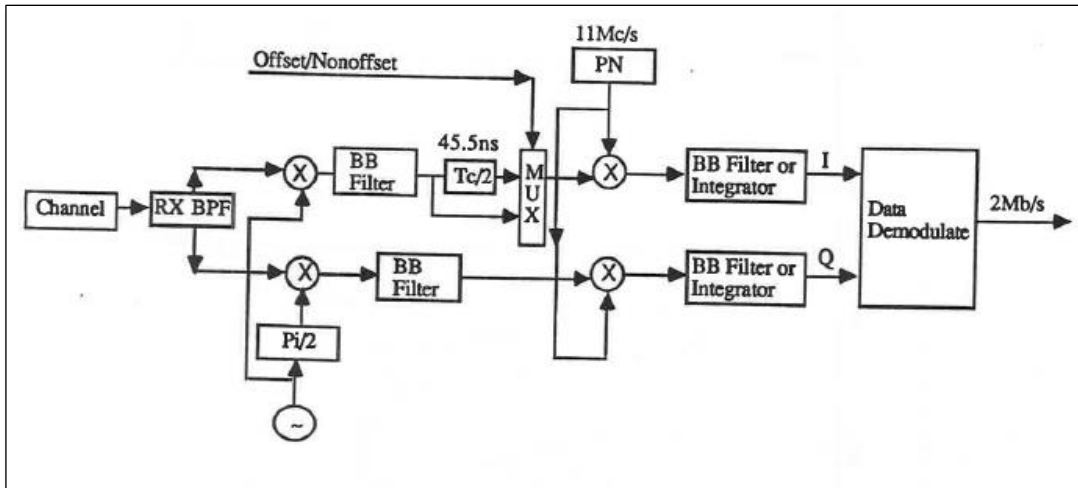

Zhen Wan and Kamilo Feher, *Wireless Access Methods and Physical Layer Specifications: Modulation Specifications for 2Mb/s DS-SS System*, IEEE P802.11-94/02 at 5 (January 1994) (“The DQPSK, OQPSK, and the compatible FQPSK DS-SS system coherent demodulator is shown in Fig.2. In the demodulator, a corresponding half chip period delay in the I-channel signal, which can be switched on for OQPSK DS-SS, is used. The de-spreaded signals are then fed to the conventional coherent DQPSK demodulator as stated in the document of Telxon (28). The demodulated data sequence is decoded by the differential decoder.”).

81. Altice ‘421 Products contain antennas that are coupled to circuitry that performs the step of identifying a carrier signal from a direct sequence spread spectrum signal. The following image shows the circuitry in the Altice FiberGateway device that identifies the carrier signal using spectrum inversion. And is coupled to the WLAN antennas.

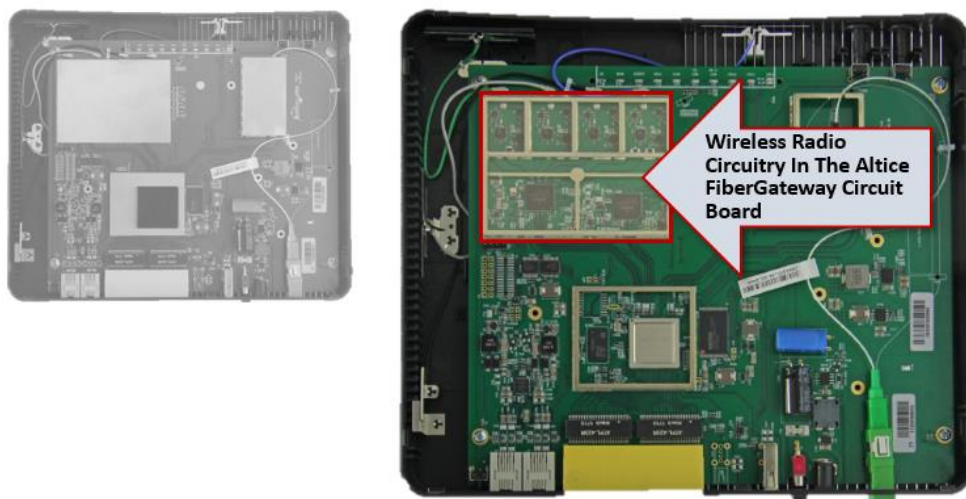

*Altice FiberGateway Model No. GR240BG Circuit Board, DEVICE TEARDOWN IMAGE (annotation added).*



82. The Altice ‘421 Products enable communication over the 2.4 GHz band using signal modulation/demodulation compliant with the IEEE 802.11b standard. The following excerpt from a submission to the United States Federal Communications Commission (“FCC”) states the Altice Amplify device operates in the 2.4GHz frequency (2412MHz to 2462MHz) and complies with the IEEE 802.11b and IEEE 802.11g standard. Further each of the 11 channels within the 2.4GHz frequency band has a specific frequency associated with the channel.

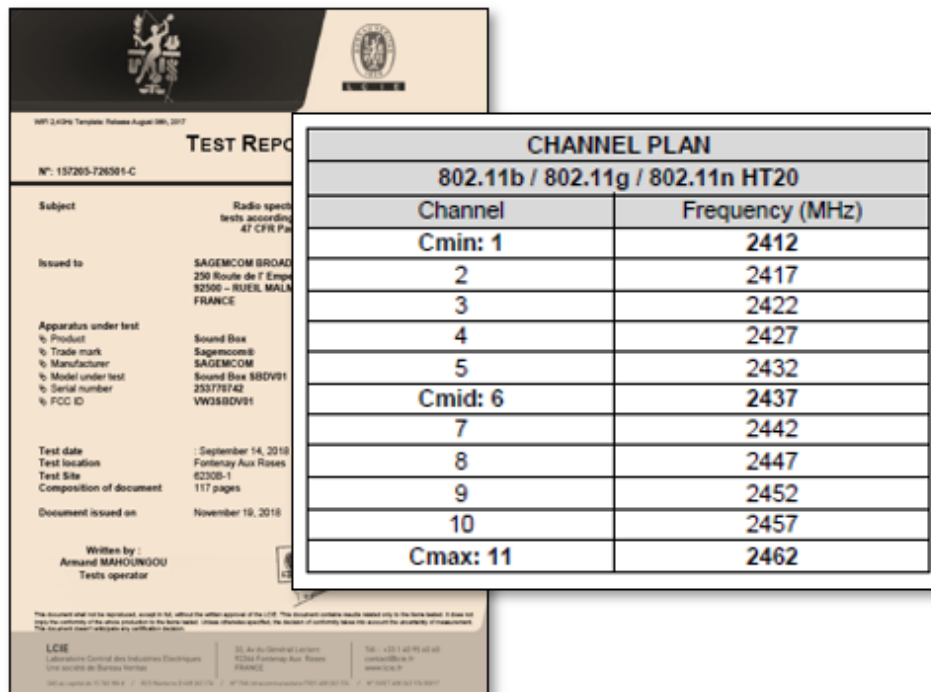

*Altice Amplify FCC ID VW3SBDV01, FCC TEST REPORT RE WiFi 2.4GHz No. 157205-726501-C at 7 (November 19, 2018).*

83. The Altice Amplify products also enable the modulation and demodulation of a DSSS signal using CCK, DBPSK, and/or DQPSK modulation. The following excerpt from a report submitted to the FCC for the Altice Amplify product identifies that the product enables these modulation types.

DATA RATE	
802.11b	
Data Rate (Mbps)	Modulation Type
1	DBPSK
2	DQPSK
5.5	DQPSK
11	CCK

Altice Amplify FCC ID VW3SBDV01, FCC TEST REPORT RE WiFi 2.4GHZ NO. 157205-726501-C at 8 (November 19, 2018) (annotation added).

84. By complying with the 802.11b and/or 802.11g standard, the Altice ‘421 Products necessarily infringe the ‘421 patent. The mandatory sections of the 802.11b and/or 802.11g standard require the elements required by certain claims of the ‘421 patent, including but not limited to claim 6 of the ‘421 patent. *Part 11: Wireless LAN Medium Access Control (MAC) and Physical Layer (PHY) Specifications*, IEEE STD 802.11 – 2016 (December 7, 2016) (hereinafter the “IEEE STD. 802.11-2016”) (The following sections of the 802.11b and 802.11g standards are relevant to Altice’s infringement of the ‘421 patent: § 9.3.3.3 Beacon frame format; § 9.4.2.4 DSSS Parameter Set element; § 15.3.2 PPDU format; § 15.3.3 PHY field definitions; § 15.3.5 PHY data modulation and modulation rate change; § 15.3.7 Receive PHY; § 15.4.4.4 Spreading sequence; § 15.4.4.7 TX-to-RX turnaround time; § 15.4.4.8 RX-to-TX turnaround time; § 16.1.3 HR/DSSS PHY Functions; § 16.2.2.2 Long PPDU format; § 16.2.3.2 Long PHY SYNC Field; § 16.2.4 PHY/HR/DSSS PHY data scrambler and descrambler; § 16.2.5 Transmit PHY; § 16.2.6 Receive PHY; § 16.3.6 PHY operating specifications, general; § 16.3.6.4 Modulation and channel data rates; § 16.3.6.8 TX-to-RX turnaround time; and § 16.3.6.9 RX-to-TX turnaround time).

85. The Altice '421 Products receive DSSS signals where an original signal is multiplied by a “noise” signal prior to transmission. The noise signal is a pseudorandom sequence of 1 and -1 values, at a frequency much higher than that of the original signal.

86. The Altice '421 Products perform the step of receiving modulated signals that comply with the 802.11b and/or 802.11g Packet Format. The modulated signals received by the Altice '421 Products are transmitted as DSSS Physical Layer Convergence Protocol (“PLCP”) Protocol Data Unit (“PPDU”). The below diagram shows the structure of a PPDU received by the Altice '421 Products. The PPDU received by the Altice '421 Products is comprised of a PLCP Preamble, PLCP Header, and MAC protocol data unit (“MPDU”).

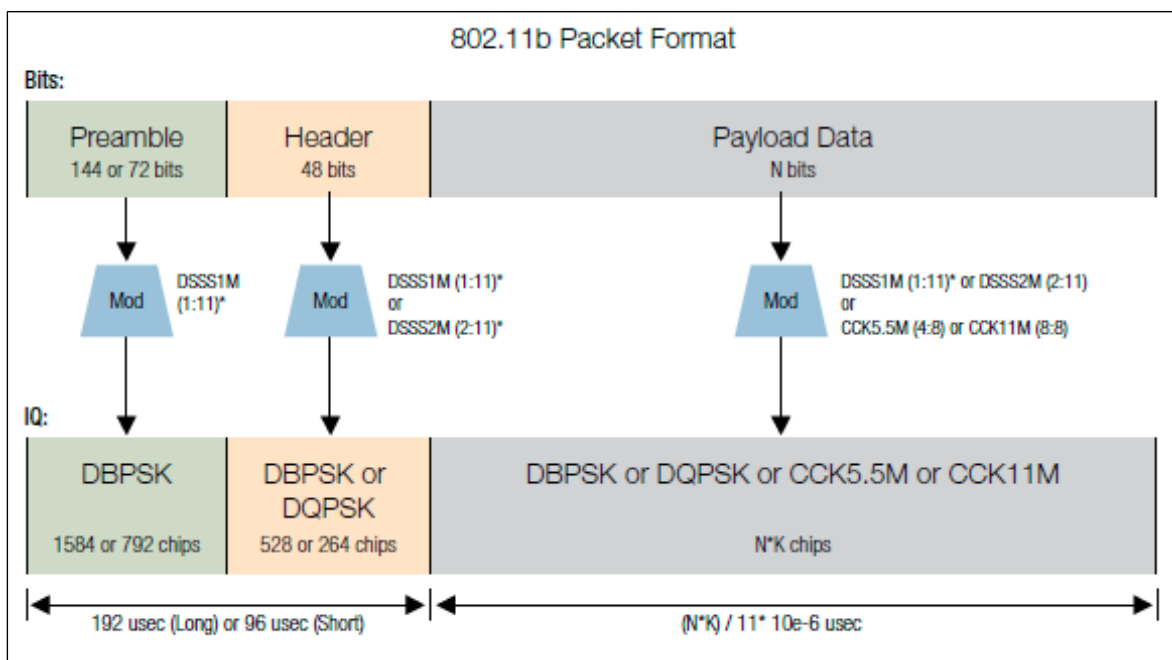

*Wi-Fi: Overview of the 802.11 Physical Layer and Transmitter Measurements*, TEKTRONIX PRIMER at 20 (November 2016).

87. The Altice '421 Products receive DSSS signals containing a PLCP Preamble that is encoded using either DBPSK or DQPSK modulation. The PLCP Preamble is a DSSS signal that consists of a Synchronization Field and Start Frame delimiter field. The Synchronization Field is “provided so the receiver [Altice '421 Products] can perform the necessary operations for

synchronization.” IEEE STD 802.11-2016 at § 15.3.3.2. The below diagram shows the structure of the DSSS signal received by the Altice ‘421 Products.

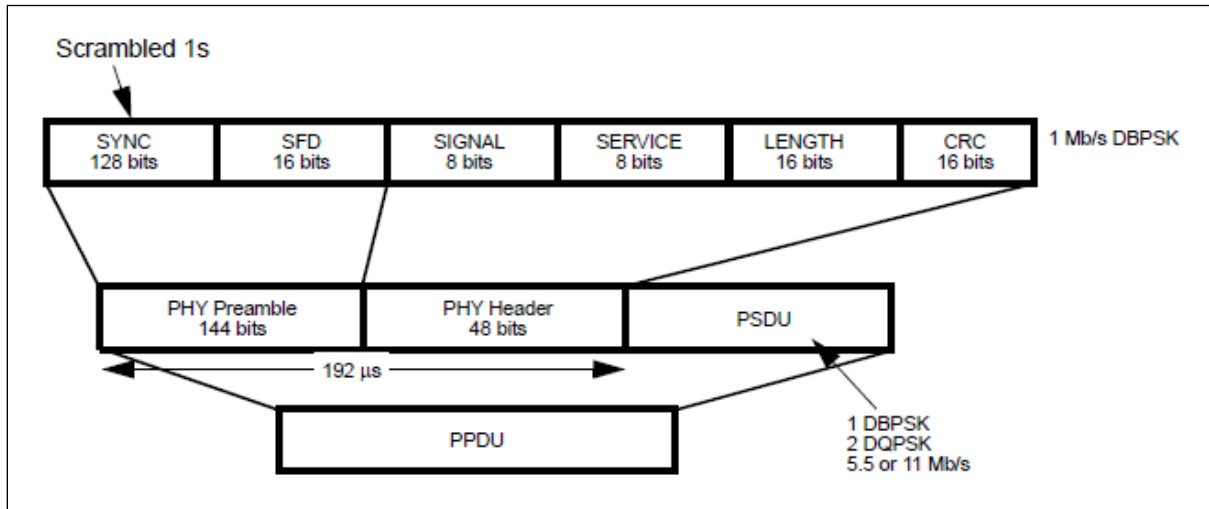

*Long PDU Format*, IEEE STD 802.11-2016 at Fig. 16-1.

88. The Altice ‘421 Products receive DSSS signals that comprise PPDUs containing a PLCP Preamble and a PLCP Service Data Unit (“PSDU”). The PLCP Preamble contains a Signal Field, Service Field, Length Field, and Cyclic Redundancy Code (“CRC”) field. The PLCP Preamble data received by the Altice ‘421 Products is modulated using either DBPSK or DQPSK to form a DSSS signal.

89. The PSDU that is received by the Altice ‘421 Products is a DSSS signal. In addition to being encoded using DBPSK or DQPSK, the PSDU data received by the Altice ‘421 Products can also be encoded using CCK modulation. CCK is a direct spread spectrum modulation scheme where input data is treated in blocks of 8 bits or 4 bits at a rate of 1.375 MHz. The following excerpt from an overview of the 802.11b standard describes how CCK modulation is performed in 802.11b at an 11Mbps transmission rate.

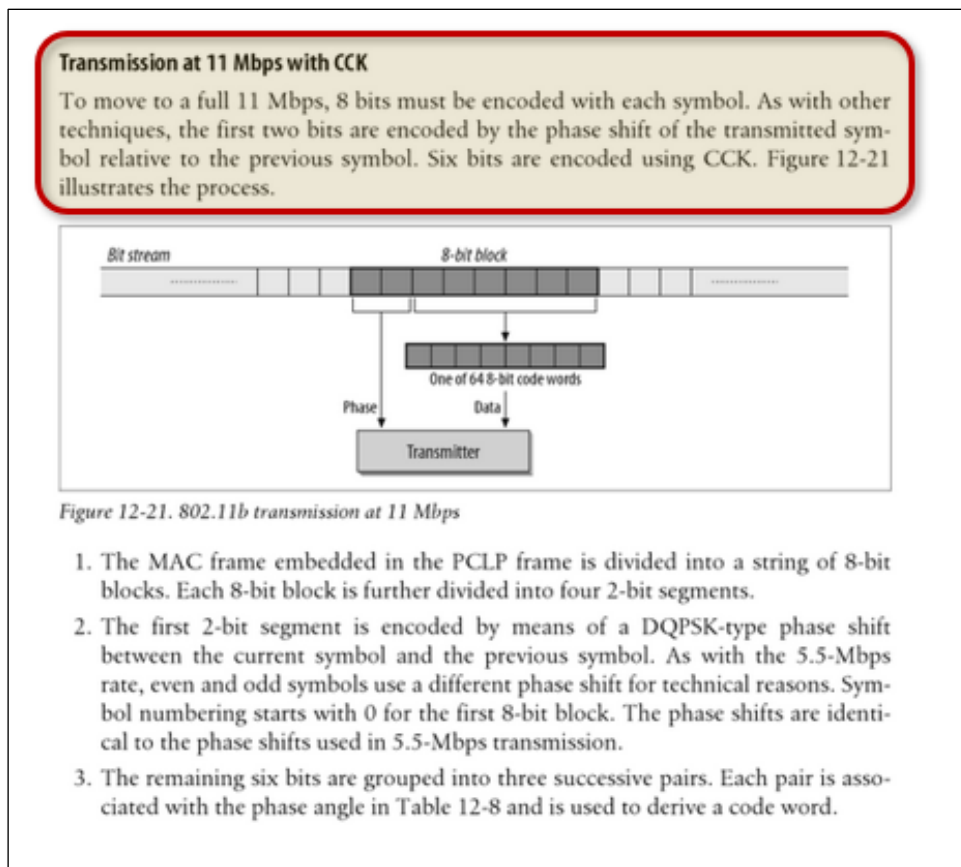

Matthew Gast, 802.11 WIRELESS NETWORKS: THE DEFINITIVE GUIDE at 273 (2005) (annotation added).

90. The Altice '421 Products contain functionality for identifying the carrier wave in wireless communications. Specifically, the Altice '421 Products perform "de-spreading" of the received PPDU. The PPDU, which is modulated using DQPSK, DBPSK and/or CCK, is correlated using a pseudo noise sequence that the Altice '421 Products believe the transmitter used. The result of this de-spreading enhances the signal to noise ratio on the channel and is called processing gain. If an undesired transmitter transmits on the same channel as the transmitted PPDU, but with a different pseudo noise sequence (or no sequence at all), the de-spreading process results in no processing gain for that undesired signal.

91. The Altice '421 Products perform the step of demodulating a DSSS signal. Specifically, the PLCP Header is demodulated using DBPSK or DQPSK. The Altice '421

Products use the SIGNAL and SERVICE fields of the PLCP Header to determine the data rate and modulation of the PSDU. The process used by the Altice '421 Products is shown in the following figure.

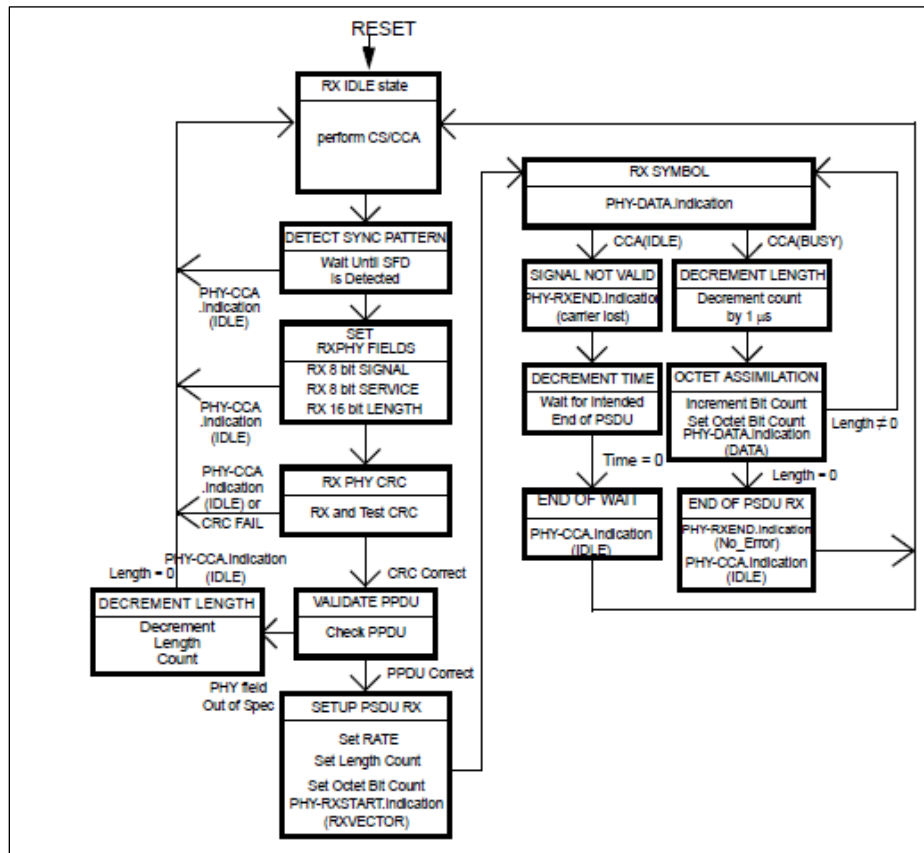

*PHY Receive State Machine*, IEEE STD 802.11-2016 at Fig. 16-9.

92. Any implementation of the 802.11b and/or 802.11g standard would infringe the '421 patent as every possible implementation of the standard requires: detecting the carrier frequency of a DSSS signal; subtracting the DSSS signal from a signal having a higher frequency than an frequency in the DSSS signal spectrum to produce DSSS signal frequency spectrum inversion; correlating the inverted and non-inverted DSSS signals at substantially zero relative time delay; and identifying the said carrier frequency from the correlation signal.

93. One or more Altice subsidiaries and/or affiliates use the Altice '421 Products in regular business operations.

94. Altice has directly infringed and continues to directly infringe the '421 patent by, among other things, making, using, offering for sale, and/or selling technology for identifying a carrier frequency from a correlation signal, including but not limited to the Altice '421 Products.

95. The Altice '421 Products are available to businesses and individuals throughout the United States.

96. The Altice '421 Products are provided to businesses and individuals located in the Western District of Texas.

97. By making, using, testing, importing, offering for sale, and/or selling products and services for identifying a carrier frequency from a correlation signal, including but not limited to the Altice '421 Products, Altice has injured Castlemorton and is liable to the Plaintiff for directly infringing one or more claims of the '421 patent, including at least claim 6 pursuant to 35 U.S.C. § 271(a).

98. The Altice also indirectly infringes the '421 patent by actively inducing infringement under 35 USC § 271(b).

99. Altice has had knowledge of the '421 patent since at least service of this Complaint or shortly thereafter, and on information and belief, Altice knew of the '421 patent and knew of its infringement, including by way of this lawsuit.

100. Altice intended to induce patent infringement by third-party customers and users of the Altice '421 Products and had knowledge that the inducing acts would cause infringement or was willfully blind to the possibility that its inducing acts would cause infringement. Altice specifically intended and was aware that the normal and customary use of the accused products

would infringe the '421 patent. Altice performed the acts that constitute induced infringement, and would induce actual infringement, with knowledge of the '421 patent and with the knowledge that the induced acts would constitute infringement. For example, Altice provides the Altice '421 Products that have the capability of operating in a manner that infringe one or more of the claims of the '421 patent, including at least claim 6, and Altice further provides documentation and training materials that cause customers and end users of the Altice '421 Products to utilize the products in a manner that directly infringe one or more claims of the '421 patent.<sup>34</sup> By providing instruction and training to customers and end-users on how to use the Altice '421 Products in a manner that directly infringes one or more claims of the '421 patent, including at least claim 6, Altice specifically intended to induce infringement of the '421 patent. On information and belief, Altice engaged in such inducement to promote the sales of the Altice '421 Products, *e.g.*, through Altice user manuals, product support, marketing materials, and training materials to actively induce the users of the accused products to infringe the '421 patent. Accordingly, Altice has induced and continues to induce users of the accused products to use the accused products in their ordinary and customary way to infringe the '421 patent, knowing that such use constitutes infringement of the '421 patent.

---

<sup>34</sup> *Altice One Guide*, SUDDENLINK DOCUMENTATION (2018); *Altice One Mini User Manual DCIWA384-UHD*, SUDDENLINK DOCUMENTATION (2018); *Altice FiberGateway GR240BG User Manual*, ALTICE DOCUMENTATION VERSION 4.1-6 (2018); *SuddenLink Business Managed WiFi – Webpage*, SUDDENLINK BUSINESS WEBSITE (last visited January 2020), available at: <https://www.suddenlinkbusiness.com/managed-services/wifi>; *Suddenlink – Using Enhanced WiFi@Work*, SUDDENLINK CUSTOMER GUIDE (September 21, 2015); *SuddenLink Enhanced WiFi@Work User Guide*, SUDDENLINK USER GUIDE (2016); *Altice One Amplify Help Support*, SUDDENLINK HELP WEBSITE (last visited January 2020), available at: <https://help.suddenlink.com/category/altice-amplify>; *Suddenlink How To Video: Altice One Quick Guide*, SUDDENLINK YOUTUBE Channel (September 6, 2018), available at: <https://www.youtube.com/watch?v=uMH1JoXQCWk>



101. To the extent applicable, the requirements of 35 U.S.C. § 287(a) have been met with respect to the '421 patent.

102. As a result of Altice's infringement of the '421 patent, Castlemorton has suffered monetary damages, and seeks recovery in an amount adequate to compensate for Altice's infringement, but in no event less than a reasonable royalty for the use made of the invention by Altice together with interest and costs as fixed by the Court.

**PRAYER FOR RELIEF**

WHEREFORE, Castlemorton respectfully requests that this Court enter:

- A. A judgment in favor of Castlemorton that Altice has infringed, either literally and/or under the doctrine of equivalents, the '421 patent;
- B. An award of damages resulting from Altice's acts of infringement in accordance with 35 U.S.C. § 284;
- C. Any and all other relief to which Castlemorton may show themselves to be entitled.

**JURY TRIAL DEMANDED**

Pursuant to Rule 38 of the Federal Rules of Civil Procedure, Castlemorton Wireless, LLC requests a trial by jury of any issues so triable by right.

Dated: January 21, 2020

Respectfully submitted,

/s/ Daniel P. Hipskind

S. Calvin Capshaw

State Bar No. 03783900

Elizabeth L. DeRieux

State Bar No. 05770585

Capshaw DeRieux, LLP

114 E. Commerce Ave.

Gladewater, TX 75647

Telephone: (903)235-2833

Email: ccapshaw@capshawlaw.com

Email: ederieux@capshawlaw.com

Dorian S. Berger (CA SB No. 264424)

Daniel P. Hipskind (CA SB No. 266763)

BERGER & HIPSKIND LLP

9538 Brighton Way, Ste. 320

Beverly Hills, CA 90210

Telephone: 323-886-3430

Facsimile: 323-978-5508

E-mail: dsb@bergerhipskind.com

E-mail: dph@bergerhipskind.com

*Attorneys for Castlemorton Wireless, LLC*