

**IN THE UNITED STATES DISTRICT COURT
FOR THE WESTERN DISTRICT OF TEXAS
WACO DIVISION**

FAR NORTH PATENTS, LLC,

Plaintiff,

v.

ANALOG DEVICES, INC.,

Defendant.

CIVIL ACTION NO. 6:20-CV-219

ORIGINAL COMPLAINT FOR
PATENT INFRINGEMENT

JURY TRIAL DEMANDED

ORIGINAL COMPLAINT FOR PATENT INFRINGEMENT

Plaintiff Far North Patents, LLC (“Far North Patents” or “Plaintiff”) files this original complaint against Defendant Analog Devices, Inc. (“Analog” or “Defendant”), alleging, based on its own knowledge as to itself and its own actions and based on information and belief as to all other matters, as follows:

PARTIES

1. Far North Patents is a limited liability company formed under the laws of the State of Texas, with its principal place of business at 18383 Preston Rd Suite 250, Dallas, Texas, 75252.

2. Defendant Analog Devices, Inc. is a company organized under the laws of the state of Massachusetts. It can be served via its registered agent CT Corp System at 1999 Bryan Street, Suite 900, Dallas, TX 75201.

JURISDICTION AND VENUE

3. This is an action for infringement of United States patents arising under 35 U.S.C. §§ 271, 281, and 284–85, among others. This Court has subject matter jurisdiction of the action under 28 U.S.C. § 1331 and § 1338(a).

4. This Court has personal jurisdiction over Analog pursuant to due process and/or the Texas Long Arm Statute because, *inter alia*, (i) Analog has done and continues to do business in Texas; (ii) Analog has committed and continues to commit acts of patent infringement in the State of Texas, including making, using, offering to sell, and/or selling accused products in Texas, and/or importing accused products into Texas, including by Internet sales and sales via retail and wholesale stores, inducing others to commit acts of patent infringement in Texas, and/or committing a least a portion of any other infringements alleged herein; and (iii) Analog is registered to do business in Texas.

5. Venue is proper in this district as to Analog pursuant to 28 U.S.C. § 1400(b). Venue is further proper because Analog has committed and continues to commit acts of patent infringement in this district, including making, using, offering to sell, and/or selling accused products in this district, and/or importing accused products into this district, including by Internet sales and sales via retail and wholesale stores, inducing others to commit acts of patent infringement in this district, and/or committing at least a portion of any other infringements alleged herein in this district. Analog also has a regular and established place of business in this district, including at 8500 N. Mopac, Suite 603, Austin, TX 78759, as stated on Analog's website:

The screenshot displays the Analog Devices website's 'Sales and Distribution' page. The header includes the company logo and navigation tabs for MYANALOG, MY HISTORY, PRODUCTS, APPLICATIONS, DESIGN CENTER, EDUCATION, and SUPPORT. A sidebar on the left lists various corporate information categories, with 'Sales and Distribution' highlighted. The main content area features a world map with regional callouts and a detailed 'Texas Sales Office' section. The Texas section provides contact details for three different sales offices: ADI South Sales in Norwood, MA; Analog Devices, Inc. Corporate Headquarters in Norwood, MA; and Southeast Region Sales in Austin, TX.

<https://www.analog.com/en/about-adi/corporate-information/sales-distribution.html>

BACKGROUND

6. The patents-in-suit generally pertain to communications networks and other technology used in the provision of wireless services, Voice over Internet Protocol (“VoIP”) phone systems, high speed networking, and other advanced communication services. The technology disclosed by the patents was developed by personnel at Path1 Network Technologies Inc. (“Path1 Network Technologies”).

7. Path1 Network Technologies is a provider of video over IP services and solutions. The patents developed at Path1 Network Technologies (“the Fellman patents”) relate to providing service guarantees for time sensitive signals in computer networks. The inventors of these patents include Dr. Ronald D. Fellman and Dr. Rene L. Cruz. Drs. Fellman and Cruz, both former professors of electrical and computer engineering at the University of California at San

Diego, were pioneers in network technology. Dr. Fellman was an IEEE Senior Member, and his work was published in several IEEE Transactions journals, including IEEE Transactions on Networking, IEEE Transactions on Parallel and Distributed Systems, IEEE Transactions on Systems, Man, and Cybernetics, IEEE Transactions on Signal Processing, IEEE Transactions on Very Large Scale Integration (VLSI) Systems, IEEE Transactions on Acoustics, Speech and Signal Processing. He was also a co-founder of Path1 Network Technologies and of Qvidium Technologies. Dr. Cruz, a distinguished scholar in the field of communication networks, was said to have established the field of Network Calculus. In Dr. Cruz's election to be a Fellow of the IEEE in 2003, he was "cited for his expertise in the area of Quality-of-Service guarantees in packet-switched networks."

http://jacobsschool.ucsd.edu/news/news_releases/release.sfe?id=1385.

8. The Fellman patents (or the applications leading to them) have been cited during patent prosecution hundreds of times, by numerous leading companies in the computer networking and telecommunications industries, including ABB Research, Alcatel, AMD, Amazon, AT&T, Atheros Communications, Avaya, Bose, Broadcom, Canon, Centurylink, Chi Mei Optoelectronics, Ciena, Cox Communications, Dell, Ericsson, F5 Networks, Fujitsu, General Electric, Hitachi, Honeywell, Intel, IBM, Lucent, Lutron, Microsoft, National Instruments, National Semiconductor, NEC, Nortel Networks, Oceaneering, Path1, Phillips, Qualcomm, Robert Bosch, Rockwell Automation, Samsung, Siemens, Sonos, Sony, Symantec, Texas Instruments, Toshiba, Ubiquiti Networks, Verizon, and Viasat.

COUNT I

DIRECT INFRINGEMENT OF U.S. PATENT NO. 8,306,053

9. On November 6, 2012, United States Patent No. 8,306,053 (“the ‘053 Patent”) was duly and legally issued by the United States Patent and Trademark Office for an invention entitled “Methods and Apparatus for Providing Quality-of-Service Guarantees in Computer Networks.”

10. Far North Patents is the owner of the ‘053 Patent, with all substantive rights in and to that patent, including the sole and exclusive right to prosecute this action and enforce the ‘053 Patent against infringers, and to collect damages for all relevant times.

11. Analog made, had made, used, imported, provided, supplied, distributed, sold, and/or offered for sale products and/or systems including, for example, its Analog Fido5000 REM switch family (5100/5200) and its Analog EVAL-RapID-TSNEK TSN Evaluation Kit families of products that include advanced quality of service capabilities (collectively, “accused products”).

ANALOG DEVICES
AHEAD OF WHAT'S POSSIBLE™

Search

MYANALOG | MY HISTORY | **PRODUCTS** | APPLICATIONS | DESIGN CENTER | EDUCATION | SUPPORT

Products > Industrial Ethernet > Industrial Ethernet Embedded Switches

Print myAnalog

Industrial Ethernet Embedded Switches

REM Switch Family Supports All Major Industrial Ethernet Protocols and Connects to Any Processor to Build Any Field Device or Controller Application.

The fido5000 REM switch family includes two 2-port, Industrial Ethernet embedded switches that interface to any processor, including any ARM® CPU and ADI's fido1100 communication controller. ADI's PriorityChannel™ technology has been integrated into their hardware architecture and designed into the REM switch software drivers. The protocols supported by these switches are PROFINET Class C (IRT) and Class B (RT), EtherNet/IP® with and without DLR, Modbus® TCP, EtherCAT®, and POWERLINK®. The REM switches come with a software driver for each protocol. The software drivers provide an API for integration with any field device or controller protocol stack. ADI is certifying REM and its software drivers at each protocol's sponsoring industry organization using ADI's RapID platform.



fido5100 data sheet, specs and more



fido5200 data sheet, specs, and more

(Source : <https://www.analog.com/en/products/industrial-ethernet/industrial-ethernet-embedded-switches.html>)

Embedded Switches

	Port Count	Protocol Support	TSN Features	Package	Power
fido5100	2	PROFINET, Ethernet/IP®, POWERLINK®, Modbus® TCP	802.1AS (Time synchronization); 802.1Qbv (Scheduled traffic); 802.1CB (Redundancy); 802.1Qcc (Configuration)	144-ball, 10 mm × 10 mm CSP_BGA	160 mW
fido5200	2	EtherCAT®, PROFINET, Ethernet/IP, POWERLINK, Modbus TCP	802.1AS (Time synchronization); 802.1Qbv (Scheduled traffic); 802.1CB (Redundancy); 802.1Qcc (Configuration)	144-ball, 10 mm × 10 mm CSP_BGA	160 mW

(Source : screenshot of PDF downloaded from <https://www.analog.com/media/en/news-marketing-collateral/solutions-bulletins-brochures/scalable-ethernet-timed-to-perfection.pdf>)

(Source : <https://www.analog.com/en/design-center/evaluation-hardware-and-software/evaluation-boards-kits/eval-rapid-tsnek.html#eb-overview>)

Product Details

The TSN Evaluation Kit is configured to provide TSN Gateway functionality in order to quickly assess TSN features and capabilities and better understand how TSN works. From there, it is possible to utilize fido5000 Real-time Ethernet Multi-protocol (REM) Switch chip to provide a TSN solution in your product's application. The figure below shows how the TSN Kit architecture relates to a "partitioned" communication architecture and to an "integrated" communications architecture.

Using the TSN gateway functionality allows a non-TSN device to participate in a TSN network without implementing TSN-specific features natively. The TSN gateway has built-in features from the following IEEE specifications:

- 802.1AS, AS-REV – Time Synchronization
- 802.1Qbv – Scheduled Traffic
- 802.1Qci – Ingress Policing
- 802.1CB – Seamless Redundancy
- 802.1Qcc – Stream Reservation Protocol
- 802.1Qbu / 802.3br – Preemption

The TSN gateway comes pre-installed with software that supports 802.1AS, 802.1Qbv, 802.1Qcc, and stream translation. Software updates will be provided to add TSN features and correct any interoperability issues. 802.1Qcc is currently implemented using a webserver, but will ultimately be implemented so the gateway can be configured by a Central Network Controller (CNC).

(Source : <https://www.analog.com/en/design-center/evaluation-hardware-and-software/evaluation-boards-kits/eval-rapid-tsnek.html#eb-overview>)

12. By doing so, Analog has directly infringed (literally and/or under the doctrine of equivalents) at least Claims 1 and 14 of the '053 Patent. Analog's infringement in this regard is ongoing.

13. Analog has infringed the '053 Patent by making, having made, using, importing, providing, supplying, distributing, selling or offering for sale products including a device adapter comprising a transmission unit configured to transmit data from a real time device via a network according to a time frame, wherein the time frame is substantially synchronized in the device adapter and at least one other device adapter, the time frame repeating periodically and including a plurality of assigned time phases and a free access phase. For example, the accused products are configured to be used to implement the IEEE 802.1Q standard. IEEE standard 802.1Q implements a method in which a time aware bridged LAN transmits data from one end point i.e., Precision Time Protocol ("PTP") instance to another. The endpoints transmit data that is a mix of time-critical traffic and other traffic, (i.e., real time data and non-real time data) via PTP instances such as bridges (device adapters). The end point can be either a real time device or a non-real time device. The bridged network uses 802.1AS base time to synchronize all the clocks of ports associated with bridges (device adapters). Using the Best Master Clock Algorithm, the synchronization time signal is transmitted from a grandmaster to other ports. IEEE Std. 802.1ASTM-2011 is normative and essential to implement an IEEE Std. 802.1Q Compliant System. IEEE Std. 802.1Q-2018 defines parameters, such as AdminBaseTime and OpenBaseTime, which are used to synchronize the clocks across the network. The bridges containing ports schedule the transmission of traffic based on the synchronized time. Each port

associated with a specific set of transmission queues includes a plurality of transmission gates. A transmission gate can be in a closed state or open state. The functionality of assigned time phases is achieved using open gates transmitting data packets during transmission time. The functionality of a free access phase is achieved when the gates are opened for transmission during any time. IEEE Std. 802.1Q-2018 supports cyclic queuing and forwarding structures to create synchronized frames and gates which repeat periodically (Annex T).

1.1 Project Number: P802.1Qbv

1.2 Type of Document: Standard

1.3 Life Cycle: Full Use

2.1 Title: Standard for Local and metropolitan area networks--Media Access Control (MAC) Bridges and Virtual Bridged Local Area Networks Amendment: Enhancements for Scheduled Traffic

5.2.b. Scope of the project: This amendment specifies time-aware queue-draining procedures, managed objects and extensions to existing protocols that enable bridges and end stations to schedule the transmission of frames based on a synchronized time. Virtual Local Area Network (VLAN) tag encoded priority values are allocated allowing simultaneous support of scheduled traffic, credit-based shaper traffic and other bridged traffic over Local Area Networks (LANs).

(Source: <http://www.ieee802.org/1/files/public/docs2014/bv-p802-1Qbv-par-modification-1114.pdf>)

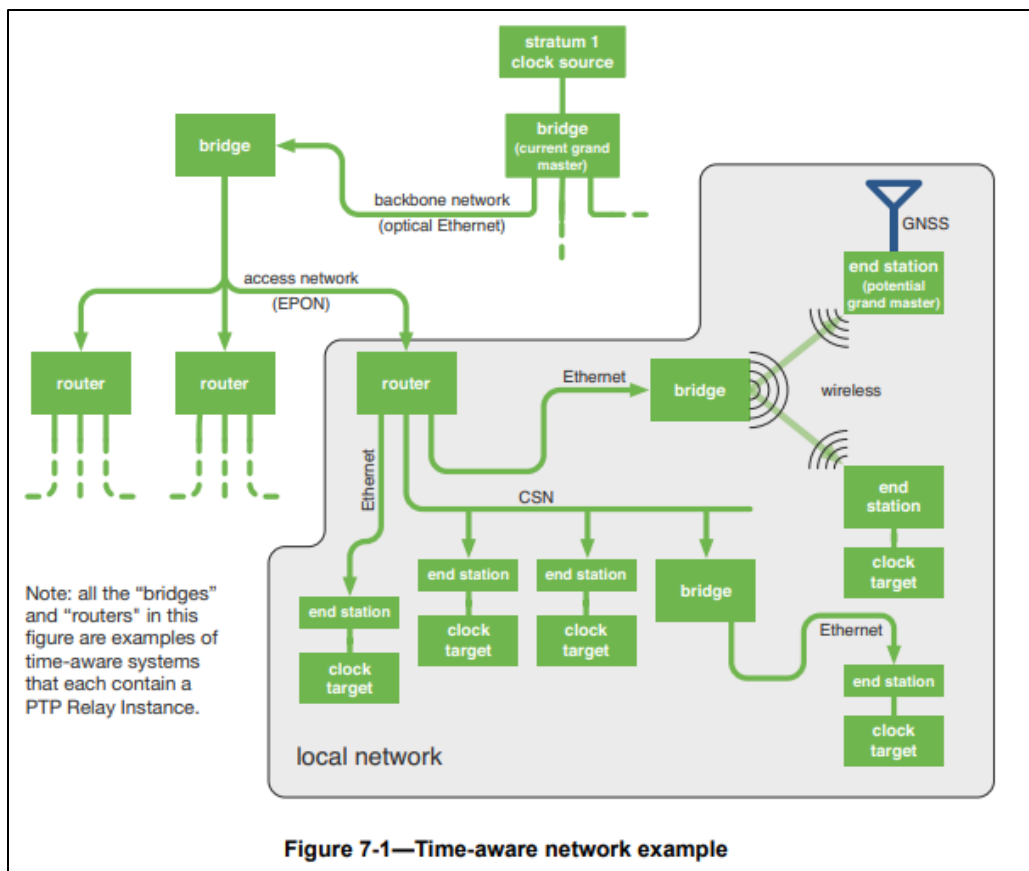

(Source: <https://1.ieee802.org/wp-content/uploads/2019/03/802-1AS-rev-d8-0.pdf>)

7.2 Architecture of a time-aware network

7.2.1 General

A time-aware network consists of a number of interconnected time-aware systems that support the gPTP defined within this standard. These time-aware systems can be any networking device, including, for example, bridges, routers, and end stations. A set of time-aware systems that are interconnected by gPTP-capable network elements is called a gPTP network. Each instance of gPTP that the time-aware systems support is in one gPTP domain, and the instances of gPTP are said to be part of that gPTP domain. A time-aware system can support, and therefore be part of, more than one gPTP domain. The entity of a single time-aware system that executes gPTP in one gPTP domain is called a PTP Instance. A time-aware system can contain multiple PTP Instances, which are each associated with a different gPTP domain. There are two

(Source: <https://1.ieee802.org/wp-content/uploads/2019/03/802-1AS-rev-d8-0.pdf>)

3.16 PTP End Instance: A PTP Instance that is capable of acting as the source of synchronized time on the network, or destination of synchronized time using the IEEE 802.1AS protocol, or both.

3.17 PTP Instance: A PTP Relay Instance or a PTP End Instance. A PTP Instance implements those portions of this standard indicated as applicable to a PTP Relay Instance or a PTP End Instance. Each PTP Instance operates in exactly one domain.

3.18 PTP Link: Within a domain, a network segment between two PTP Ports using the peer-to-peer delay mechanism of this standard. The peer-to-peer delay mechanism is designed to measure the propagation time over such a link.

NOTE—A PTP Link between PTP Ports of PTP Instances is also a gPTP Communication Path (see 3.9).

3.19 PTP Relay Instance: A PTP Instance that is capable of communicating synchronized time received on one port to other ports, using the IEEE 802.1AS protocol.

NOTE—A PTP Relay Instance could, for example, be contained in a bridge, a router, or a multi-port end station.

(Source: <https://1.ieee802.org/wp-content/uploads/2019/03/802-1AS-rev-d8-0.pdf>)

Traffic scheduling

This annex provides some background to the mechanisms provided in this standard for traffic scheduling, with the intent of providing some insight into the motivation for the provision of mechanisms for traffic scheduling and some of the ways that the mechanisms might be used.

Q.1 Motivation

Some applications have a need for frame delivery that is highly predictable in terms of the time at which frame transmission will occur, and the overall latency and jitter that will be experienced as the frame is propagated to its destination. Examples include industrial and automotive control applications, where data transmitted over the network is used to feed the parameters of control loops that are critical to the operation of the plant or machinery involved, and where frames carrying control data are transmitted on a repeating time schedule; late delivery of such frames can result in instability, inaccuracy, or failure of the operation of the control loops concerned. In some implementations, this need has been met by the provision of dedicated, highly engineered networks that are used solely for the transmission of time-critical control traffic; however, as the bandwidth occupied by such traffic is often low, and the cost of providing a dedicated control network can be high, it can be desirable to mix time-critical traffic with other classes of traffic in the same network, as long as such mixing can be achieved while still meeting the timing requirements of the time-critical traffic.

(Source: IEEE Standard for Local and metropolitan area networks— Bridges and Bridged Networks Amendment 25: Enhancements for Scheduled Traffic (IEEE 802.1Qbv-2015))

- b) gPTP specifies a media-independent sublayer that simplifies the integration within a single timing domain of multiple different networking technologies with radically different media access protocols. gPTP specifies a media-dependent sublayer for each medium. The information exchanged between PTP Instances has been generalized to support different packet formats and management schemes appropriate to the particular networking technology. IEEE Std 1588-2019, on the other

(Source: <https://1.ieee802.org/wp-content/uploads/2019/03/802-1AS-rev-d8-0.pdf>)

7.2.2 Time-aware network consisting of a single gPTP domain

Figure 7-1 illustrates an example time-aware network consisting of a single gPTP domain, using all the above network technologies (i.e., (c) - (f) of 7.2.1), where end stations on several local networks are connected to a grandmaster on a backbone network via an EPON access network.

Any PTP Instance with clock sourcing capabilities can be a potential grandmaster, so there is a selection method (the best master clock algorithm, or BMCA) that ensures that all of the PTP Instances in a gPTP domain use the same grandmaster.¹² The BMCA is largely identical to that used in IEEE Std 1588-2019,

(Source: <https://1.ieee802.org/wp-content/uploads/2019/03/802-1AS-rev-d8-0.pdf>)

10.3.1.1 Best master clock algorithm overview

In the BMCA (i.e., method (a) of 10.3.1), best master selection information is exchanged between PTP Instances of time-aware systems via Announce messages (see 10.5 and 10.6). Each Announce message contains time-synchronization spanning tree vector information that identifies one PTP Instance as the root of the time-synchronization spanning tree and, if the PTP Instance is grandmaster-capable, the grandmaster. Each PTP Instance in turn uses the information contained in the Announce messages it receives, along with its knowledge of itself, to compute which of the PTP Instances that it has knowledge of ought to be the root of the spanning tree and, if grandmaster-capable, the grandmaster. As part of constructing the time-synchronization spanning tree, each port of each PTP Instance is assigned a port state from Table 10-2 by state machines associated with the ports and with the PTP Instance as a whole.

(Source: <https://1.ieee802.org/wp-content/uploads/2019/03/802-1AS-rev-d8-0.pdf>)

- c) In gPTP there are only two types of PTP Instances: PTP End Instances and PTP Relay Instances, while IEEE 1588 has ordinary clocks, boundary clocks, end-to-end transparent clocks, and P2P transparent clocks. A PTP End Instance corresponds to an IEEE 1588 ordinary clock, and a PTP Relay Instance is a type of IEEE 1588 boundary clock where its operation is very tightly defined, so much so that a PTP Relay Instance with Ethernet ports can be shown to be mathematically equivalent to a P2P transparent clock in terms of how synchronization is performed, as shown in

(Source: <https://1.ieee802.org/wp-content/uploads/2019/03/802-1AS-rev-d8-0.pdf>)

- **Grand Master selection**
 - GM-capable stations advertise themselves via ANNOUNCE messages
 - If a station hears from station with “better” clock, it does not send ANNOUNCE
 - Configurable “Priority” field can override clock quality
 - MAC address is tie breaker
 - Time relays drop all inferior ANNOUNCE messages
 - Forward only the best
 - Last one standing is Grand Master for the domain
 - GM is the root of the 802.1AS timing tree
 - GM periodically sends the current time

(Source: <https://avnu.org/wp-content/uploads/2014/05/as-kbstanton-8021AS-tutorial-0714-v01.pdf>)

IEEE Std 802.1Q-2018
IEEE Standard for Local and Metropolitan Area Networks—Bridges and Bridged Networks

2. Normative references

The following referenced documents are indispensable for the application of this document (i.e., they must be understood and used, so each referenced document is cited in the text and its relationship to this document is explained). For dated references, only the edition cited applies. For undated references, the latest edition of the referenced document (including any amendments or corrigenda) applies.

ANSI X3.159, American National Standards for Information Systems—Programming Language—C.⁵

IEEE Std 802[®], IEEE Standard for Local and metropolitan area networks: Overview and Architecture.^{6,7}

IEEE Std 802.1AB[™], IEEE Standard for Local and metropolitan area networks—Station and Media Access Control Connectivity Discovery.

IEEE Std 802.1AC[™], IEEE Standard for Local and metropolitan area networks—Media Access Control (MAC) Service Definition.

IEEE Std 802.1AE[™], IEEE Standard for Local and metropolitan area networks—Media Access Control (MAC) Security.

IEEE Std 802.1AS[™], IEEE Standard for Local and metropolitan area networks—Timing and Synchronization for Time-Sensitive Applications in Bridged Local Area Networks.

(Source: IEEE Standard for Local and Metropolitan Area Networks—Bridges and Bridged Networks- IEEE Std 802.1Q[™]-2018)

8.6.9.4.1 AdminBaseTime

The administrative value of base time, expressed as an IEEE 1588 precision time protocol (PTP) [B24] timescale (see 8.2 of IEEE Std 802.1AS™-2011 [B11]). This value can be changed by management, and is used by the List Config state machine (8.6.9.3) to set the value of OperBaseTime (8.6.9.4.18).

NOTE—Time is expressed in the PTP timescale as the number of seconds, nanoseconds, and fractional nanoseconds that have elapsed since 1 January 1970 00:00:00 TAI.

NOTE 2—If AdminBaseTime is set to the same time in the past in all bridges and end stations, OperBaseTime is always in the past, and all cycles start synchronized. Using AdminBaseTime in the past is appropriate when you can start schedules prior to starting the application that uses the schedules. Use of AdminBaseTime in the future is intended to change a currently running schedule in all bridges and end stations to a new schedule at a future time. Using AdminBaseTime in the future is appropriate when schedules must be changed without stopping the application.

(Source: IEEE Standard for Local and Metropolitan Area Networks—Bridges and Bridged Networks- IEEE Std 802.1Q™-2018)

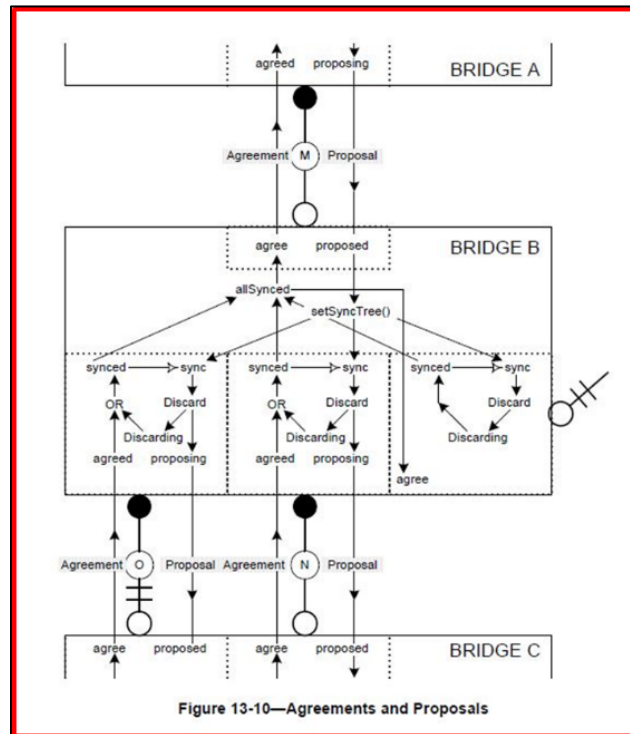

(Source: IEEE Standard for Local and Metropolitan Area Networks—Bridges and Bridged Networks- IEEE Std 802.1Q™-2018)

NOTE 2—Agreements can be generated without prior receipt of a Proposal as soon as the necessary conditions are met. Subsequent receipt of a Proposal serves to elicit a further Agreement. If all other ports have already been synchronized (allSynced in Figure 13-10) and the Proposal's priority vector does not convey worse information, synchronization is maintained and there is no need to transition Designated Ports to Discarding once more, or to transmit further Proposals.

(Source: IEEE Standard for Local and Metropolitan Area Networks—Bridges and Bridged Networks- IEEE Std 802.1Q™-2018)

8.6.8.4 Enhancements for scheduled traffic

A Bridge or an end station may support enhancements that allow transmission from each queue to be scheduled relative to a known timescale. In order to achieve this, a transmission gate is associated with each queue; the state of the transmission gate determines whether or not queued frames can be selected for transmission (see Figure 8-12). For a given queue, the transmission gate can be in one of two states:

- a) Open: Queued frames are selected for transmission, in accordance with the definition of the transmission selection algorithm associated with the queue.
- b) Closed: Queued frames are not selected for transmission.

(Source: IEEE Standard for Local and metropolitan area networks— Bridges and Bridged Networks Amendment 25: Enhancements for Scheduled Traffic (IEEE 802.1Qbv-2015))

8.6.8 Transmission selection

For each Port, frames are selected for transmission on the basis of the traffic classes that the Port supports and the operation of the transmission selection algorithms supported by the corresponding queues on that Port. For a given Port and traffic class, frames are selected from the corresponding queue for transmission if and only if

- a) The operation of the transmission selection algorithm supported by that queue determines that there is a frame available for transmission; and
- b) For each queue corresponding to a numerically higher value of traffic class supported by the Port, the operation of the transmission selection algorithm supported by that queue determines that there is no frame available for transmission.

(Source: IEEE Standard for Local and Metropolitan Area Networks—Bridges and Bridged Networks- IEEE Std 802.1Q™-2018)

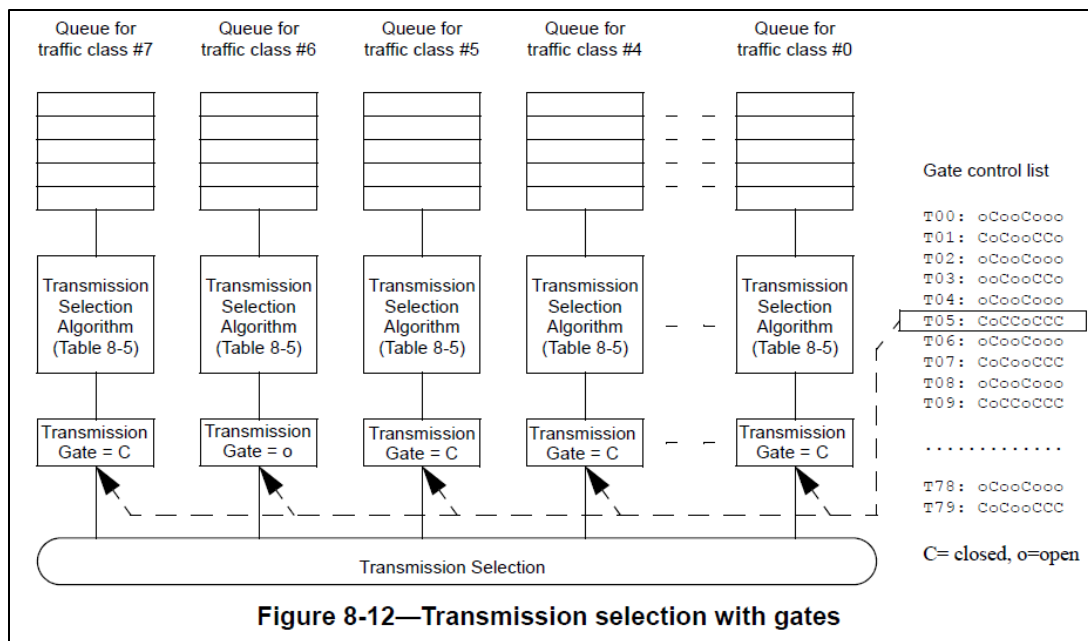

(Source: IEEE Standard for Local and metropolitan area networks— Bridges and Bridged Networks Amendment 25: Enhancements for Scheduled Traffic (IEEE 802.1Qbv-2015))

A gate control list associated with each Port contains an ordered list of gate operations. Each gate operation changes the transmission gate state for the gate associated with each of the Port's traffic class queues. In an implementation that does not support enhancements for scheduled traffic, all gates are assumed to be permanently in the open state. Table 8-6 identifies the gate operation types, their parameters, and the actions that result from their execution. The state machines that control the execution of the gate control list, along with their variables and procedures, are specified in 8.6.9.

(Source: IEEE Standard for Local and metropolitan area networks— Bridges and Bridged Networks Amendment 25: Enhancements for Scheduled Traffic (IEEE 802.1Qbv-2015)).

3.3 gating cycle: The period of time over which the sequence of operations in a gate control list repeats.

3.4 transmission gate: A gate that connects or disconnects the transmission selection function of the forwarding process from the queue, allowing or preventing it from selecting frames from that queue. The gate has two states, Open and Closed.

(Source: IEEE Standard for Local and metropolitan area networks— Bridges and Bridged Networks Amendment 25: Enhancements for Scheduled Traffic (IEEE 802.1Qbv-2015))

Cyclic queuing and forwarding⁵³

T.1 Overview of CQF

Cyclic queuing and forwarding (CQF) is a method of traffic shaping that can deliver deterministic, and easily calculated, latency for time-sensitive traffic streams. As the name implies, the principle underlying CQF is that stream traffic is transmitted and queued for transmission along a network path in a cyclic manner. Time is divided into numbered time intervals $i, i+1, i+2, \dots, i+N$, each of duration d . Frames transmitted by a Bridge, *Alice*, during time interval i are received by a downstream Bridge, *Bob*, during time interval i and are transmitted onwards by *Bob* towards Bridge *Charlie* during time interval $i+1$, and so on. A starting assumption is that, for a given traffic class, all Bridges and all end stations connected to a given bridge have a common understanding (to a known accuracy) of the start time of cycle i , and the cycle duration, d .

Frames transmitted by *Alice* during interval i are transmitted by *Bob* in interval $i+1$; the maximum possible delay experienced by a given frame is from the beginning of i to the end of $i+1$, or twice d . Similarly, the minimum possible delay experienced is from the end of i to the beginning of $i+1$, which is zero. More generally, the maximum delay experienced by a given frame is

$$(h+1) \times d$$

and the minimum delay experienced by a given frame is

$$(h-1) \times d$$

where h is the number of hops.

(Source: IEEE Standard for Local and Metropolitan Area Networks—Bridges and Bridged Networks- IEEE Std 802.1Q™-2018)

14. The accused products include a device adapter that is configured to transmit data during at least one of an assigned time phase associated with the device adapter prior to transmission of data from the real-time device by the device adapter, and included in the plurality of assigned time phases, or the free access phase, to refrain from transmitting data during time phases of the plurality of assigned time phases that are not associated with the device adapter, and to be able to determine whether to defer transmission of data during the assigned time phase associated with the device adapter and the free access phase to allow a non-real time device to transmit data. For example, the accused products are configured to be used to implement the IEEE 802.1Q standard. IEEE standard 802.1Q shows that scheduling of ports' transmission gates for transmission of data starts prior to the transmission of real-time data. The functionality

of assigned time phases is achieved using open gates transmitting data packets during scheduled transmission time. Per Clause 8.6.8 of the IEEE Std. 802.1Q, each time phase is assigned to a specific device adapter prior to transmission of real-time data by the specific device adapter. Furthermore, IEEE 802.1Q performs traffic shaping through Per-Stream Filtering and Policing (PSTP). IEEE standard 802.1Q implements a method in which open gates transmit data packets during transmission time and closed gates refrain data packets from transmission. The functionality of assigned time phases is achieved using open gates transmitting data packets during transmission time. The functionality of free access phase is achieved by the gates that are opened for transmission during any time. IEEE Std. 802.1Q supports Forwarding and Queuing Enhancements for Time Sensitive Streams. Thus, one of the plurality of device adapters is configured to transmit data during at least one of a respective assigned time phase or free access phase, to refrain from transmitting data during time phases not assigned to the respective one of the plurality of device adapters. IEEE Std. 802.1Q provides traffic shaping for various classes of data transmission and determining whether to defer transmission of data during at least one of the assigned time phase or the free access phase to allow a non-real time device to transmit data.

NOTE 2—If AdminBaseTime is set to the same time in the past in all bridges and end stations, OperBaseTime is always in the past, and all cycles start synchronized. Using AdminBaseTime in the past is appropriate when you can start schedules prior to starting the application that uses the schedules. Use of AdminBaseTime in the future is intended to

(Source: IEEE Standard for Local and metropolitan area networks— Bridges and Bridged Networks Amendment 25: Enhancements for Scheduled Traffic (IEEE 802.1Qbv-2015))

1.1 Project Number: P802.1Qbv
1.2 Type of Document: Standard
1.3 Life Cycle: Full Use

5.5 Need for the Project: The credit-based shaper works well in arbitrary networks (i.e., non-engineered). Networks employing scheduled transmissions are able to control real-time processes. This amendment enables those two kinds of networks to be consolidated into a single network, with a significant cost reduction to the user.

(Source: <http://www.ieee802.org/1/files/public/docs2014/bv-p802-1Qbv-par-modification-1114.pdf>)

8.6.8 Transmission selection

For each Port, frames are selected for transmission on the basis of the traffic classes that the Port supports and the operation of the transmission selection algorithms supported by the corresponding queues on that Port. For a given Port and traffic class, frames are selected from the corresponding queue for transmission if and only if

- a) The operation of the transmission selection algorithm supported by that queue determines that there is a frame available for transmission; and
- b) For each queue corresponding to a numerically higher value of traffic class supported by the Port, the operation of the transmission selection algorithm supported by that queue determines that there is no frame available for transmission.

(Source: IEEE Standard for Local and Metropolitan Area Networks—Bridges and Bridged Networks- IEEE Std 802.1Q™-2018)

5.4.1.9 Cyclic queuing and forwarding (CQF) requirements

A VLAN Bridge component implementation that conforms to the provisions of this standard for CQF (see Annex T) shall

- a) Support the enhancements for scheduled traffic as specified in 8.6.8.4.
- b) Support the state machines for scheduled traffic as specified in 8.6.9.
- c) Support the state machines for stream gate control as specified in 8.6.10.
- d) Support the management entities for scheduled traffic as specified in 12.29.
- e) Support the requirements for per-stream filtering and policing (PSFP) as stated in 5.4.1.8.
- f) Support the management entities for PSFP as specified in 12.31.

(Source: IEEE Standard for Local and Metropolitan Area Networks—Bridges and Bridged Networks- IEEE Std 802.1Q™-2018)

5.4.1.5 Forwarding and Queuing Enhancements for time-sensitive streams (FQTSS)—requirements

A VLAN Bridge component implementation that conforms to the provisions of this standard for FQTSS shall

- a) Support a minimum of two traffic classes on all Ports, of which
 - 1) A minimum of one traffic class supports the strict priority algorithm for transmission selection (8.6.8.1), and
 - 2) One traffic class is a stream reservation (SR) class.
- b) Support the operation of the credit-based shaper algorithm (8.6.8.2) on all Ports as the transmission selection algorithm used for the SR class.
- c) Support SRP domain boundary port priority regeneration override as defined in 6.9.4, and the default priority regeneration override value defined in Table 6-5, for SR class “B.”
- d) Support the tables and procedures for mapping priorities to traffic classes as defined in 34.5.

SR: Stream Reservation, SRP: Stream Reservation Protocol

(Source: IEEE Standard for Local and Metropolitan Area Networks—Bridges and Bridged Networks- IEEE Std 802.1Q™-2018)

8.6.8.4 Enhancements for scheduled traffic

A Bridge or an end station may support enhancements that allow transmission from each queue to be scheduled relative to a known timescale. In order to achieve this, a transmission gate is associated with each queue; the state of the transmission gate determines whether or not queued frames can be selected for transmission (see Figure 8-12). For a given queue, the transmission gate can be in one of two states:

- a) *Open*: Queued frames are selected for transmission, in accordance with the definition of the transmission selection algorithm associated with the queue.
- b) *Closed*: Queued frames are not selected for transmission.

(Source: IEEE Standard for Local and metropolitan area networks— Bridges and Bridged Networks Amendment 25: Enhancements for Scheduled Traffic (IEEE 802.1Qbv-2015))

A *gate control list* associated with each Port contains an ordered list of gate operations. Each gate operation changes the transmission gate state for the gate associated with each of the Port’s traffic class queues. In an implementation that does not support enhancements for scheduled traffic, all gates are assumed to be permanently in the *open* state. Table 8-6 identifies the gate operation types, their parameters, and the actions that result from their execution. The state machines that control the execution of the gate control list, along with their variables and procedures, are specified in 8.6.9.

(Source: IEEE Standard for Local and metropolitan area networks— Bridges and Bridged Networks Amendment 25: Enhancements for Scheduled Traffic (IEEE 802.1Qbv-2015))

5.4.1.5 Forwarding and Queuing Enhancements for time-sensitive streams (FQTSS)—requirements

A VLAN Bridge component implementation that conforms to the provisions of this standard for FQTSS shall

- a) Support a minimum of two traffic classes on all Ports, of which
 - 1) A minimum of one traffic class supports the strict priority algorithm for transmission selection (8.6.8.1), and
 - 2) One traffic class is a stream reservation (SR) class.
- b) Support the operation of the credit-based shaper algorithm (8.6.8.2) on all Ports as the transmission selection algorithm used for the SR class.
- c) Support SRP domain boundary port priority regeneration override as defined in 6.9.4, and the default priority regeneration override value defined in Table 6-5, for SR class "B."
- d) Support the tables and procedures for mapping priorities to traffic classes as defined in 34.5.

SR: Stream Reservation, SRP: Stream Reservation Protocol

(Source: IEEE Standard for Local and Metropolitan Area Networks—Bridges and Bridged Networks- IEEE Std 802.1Q™-2018)

5.4.1.6 ETS Bridge requirements

A device supporting ETS shall

- a) Support at least 3 traffic classes (37.3).

NOTE—A minimum of 3 traffic classes allows a minimum configuration such that one traffic class contains priorities with PFC enabled, one traffic class contains priorities with PFC disabled, and one traffic class using strict priority.

- b) Support bandwidth configuration with a granularity of 1% or finer (37.3).
- c) Support bandwidth allocation with a precision of 10% (37.3).
- d) Support a transmission selection policy such that if one of the traffic classes does not consume its allocated bandwidth, then any unused bandwidth is available to other traffic classes (37.3).
- e) Support DCBX (Clause 38).

(Source: IEEE Standard for Local and Metropolitan Area Networks—Bridges and Bridged Networks- IEEE Std 802.1Q™-2018)

15. Analog has infringed the '053 Patent by using the accused products and thereby practicing a method that includes transmitting a synchronization signal at regular intervals to synchronize local clocks of each of a plurality of device adapters. For example, the accused products are used by Analog to implement the IEEE 802.1Q standard. IEEE standard 802.1Q implements a method in which a time aware bridged LAN use 802.1AS base time to synchronize

all the clocks of ports associated with bridges (device adapters) by periodically (regular intervals) sending the Announce messages. Using Best Master Clock Algorithm, the synchronization time signal is transmitted from a grandmaster to other ports via periodic Announce messages. IEEE Std. 802.1AS™-2011 is normative and essential to implement an IEEE Std. 802.1Q Compliant System. IEEE Std. 802.1Q-2018 defines parameters, such as AdminBaseTime and OpenBaseTime, which are used to synchronize the clocks across the network.

1.1 Project Number: P802.1Qbv

1.2 Type of Document: Standard

1.3 Life Cycle: Full Use

2.1 Title: Standard for Local and metropolitan area networks--Media Access Control (MAC) Bridges and Virtual Bridged Local Area Networks Amendment: Enhancements for Scheduled Traffic

5.2.b. Scope of the project: This amendment specifies time-aware queue-draining procedures, managed objects and extensions to existing protocols that enable bridges and end stations to schedule the transmission of frames based on a synchronized time. Virtual Local Area Network (VLAN) tag encoded priority values are allocated allowing simultaneous support of scheduled traffic, credit-based shaper traffic and other bridged traffic over Local Area Networks (LANs).

(Source: <http://www.ieee802.org/1/files/public/docs2014/bv-p802-1Qbv-par-modification-1114.pdf>)

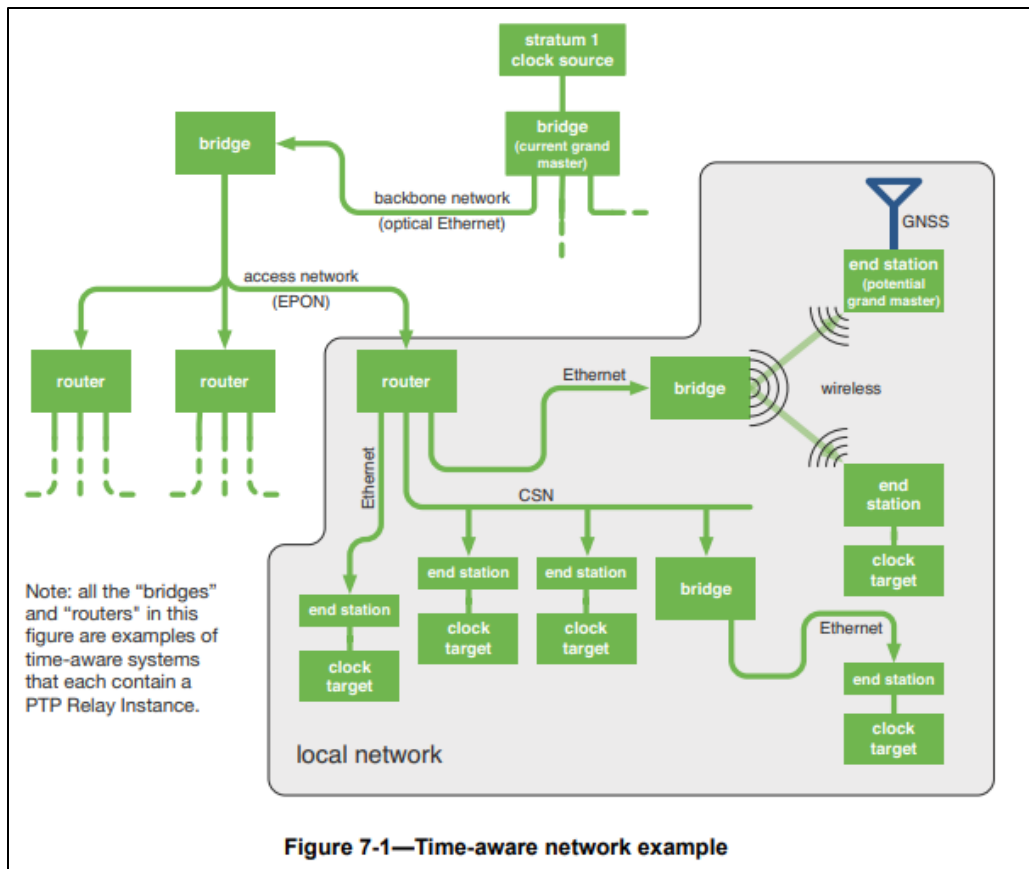

(Source: <https://1.ieee802.org/wp-content/uploads/2019/03/802-1AS-rev-d8-0.pdf>)

7.2 Architecture of a time-aware network

7.2.1 General

A time-aware network consists of a number of interconnected time-aware systems that support the gPTP defined within this standard. These time-aware systems can be any networking device, including, for example, bridges, routers, and end stations. A set of time-aware systems that are interconnected by gPTP-capable network elements is called a gPTP network. Each instance of gPTP that the time-aware systems support is in one gPTP domain, and the instances of gPTP are said to be part of that gPTP domain. A time-aware system can support, and therefore be part of, more than one gPTP domain. The entity of a single time-aware system that executes gPTP in one gPTP domain is called a PTP Instance. A time-aware system can contain multiple PTP Instances, which are each associated with a different gPTP domain. There are two

(Source: <https://1.ieee802.org/wp-content/uploads/2019/03/802-1AS-rev-d8-0.pdf>)

3.16 PTP End Instance: A PTP Instance that is capable of acting as the source of synchronized time on the network, or destination of synchronized time using the IEEE 802.1AS protocol, or both.

3.17 PTP Instance: A PTP Relay Instance or a PTP End Instance. A PTP Instance implements those portions of this standard indicated as applicable to a PTP Relay Instance or a PTP End Instance. Each PTP Instance operates in exactly one domain.

3.18 PTP Link: Within a domain, a network segment between two PTP Ports using the peer-to-peer delay mechanism of this standard. The peer-to-peer delay mechanism is designed to measure the propagation time over such a link.

NOTE—A PTP Link between PTP Ports of PTP Instances is also a gPTP Communication Path (see 3.9).

3.19 PTP Relay Instance: A PTP Instance that is capable of communicating synchronized time received on one port to other ports, using the IEEE 802.1AS protocol.

NOTE—A PTP Relay Instance could, for example, be contained in a bridge, a router, or a multi-port end station.

(Source: <https://1.ieee802.org/wp-content/uploads/2019/03/802-1AS-rev-d8-0.pdf>)

7.2.2 Time-aware network consisting of a single gPTP domain

Figure 7-1 illustrates an example time-aware network consisting of a single gPTP domain, using all the above network technologies (i.e., (c) - (f) of 7.2.1), where end stations on several local networks are connected to a grandmaster on a backbone network via an EPON access network.

Any PTP Instance with clock sourcing capabilities can be a potential grandmaster, so there is a selection method (the *best master clock algorithm*, or BMCA) that ensures that all of the PTP Instances in a gPTP domain use the same grandmaster.¹² The BMCA is largely identical to that used in IEEE Std 1588-2019,

(Source: <https://1.ieee802.org/wp-content/uploads/2019/03/802-1AS-rev-d8-0.pdf>)

10.3.1.1 Best master clock algorithm overview

In the BMCA (i.e., method (a) of 10.3.1), best master selection information is exchanged between PTP Instances of time-aware systems via Announce messages (see 10.5 and 10.6). Each Announce message contains time-synchronization spanning tree vector information that identifies one PTP Instance as the root of the time-synchronization spanning tree and, if the PTP Instance is grandmaster-capable, the grandmaster. Each PTP Instance in turn uses the information contained in the Announce messages it receives, along with its knowledge of itself, to compute which of the PTP Instances that it has knowledge of ought to be the root of the spanning tree and, if grandmaster-capable, the grandmaster. As part of constructing the time-synchronization spanning tree, each port of each PTP Instance is assigned a port state from Table 10-2 by state machines associated with the ports and with the PTP Instance as a whole.

(Source: <https://1.ieee802.org/wp-content/uploads/2019/03/802-1AS-rev-d8-0.pdf>)

c) In gPTP there are only two types of PTP Instances: PTP End Instances and PTP Relay Instances, while IEEE 1588 has ordinary clocks, boundary clocks, end-to-end transparent clocks, and P2P transparent clocks. A PTP End Instance corresponds to an IEEE 1588 ordinary clock, and a PTP Relay Instance is a type of IEEE 1588 boundary clock where its operation is very tightly defined, so much so that a PTP Relay Instance with Ethernet ports can be shown to be mathematically equivalent to a P2P transparent clock in terms of how synchronization is performed, as shown in

(Source: <https://1.ieee802.org/wp-content/uploads/2019/03/802-1AS-rev-d8-0.pdf>)

- **Grand Master selection**
 - GM-capable stations advertise themselves via ANNOUNCE messages
 - If a station hears from station with “better” clock, it does not send ANNOUNCE
 - Configurable “Priority” field can override clock quality
 - MAC address is tie breaker
 - Time relays drop all inferior ANNOUNCE messages
 - Forward only the best
 - Last one standing is Grand Master for the domain
 - GM is the root of the 802.1AS timing tree
 - GM periodically sends the current time

(Source: <https://avnu.org/wp-content/uploads/2014/05/as-kbstanton-8021AS-tutorial-0714-v01.pdf>)

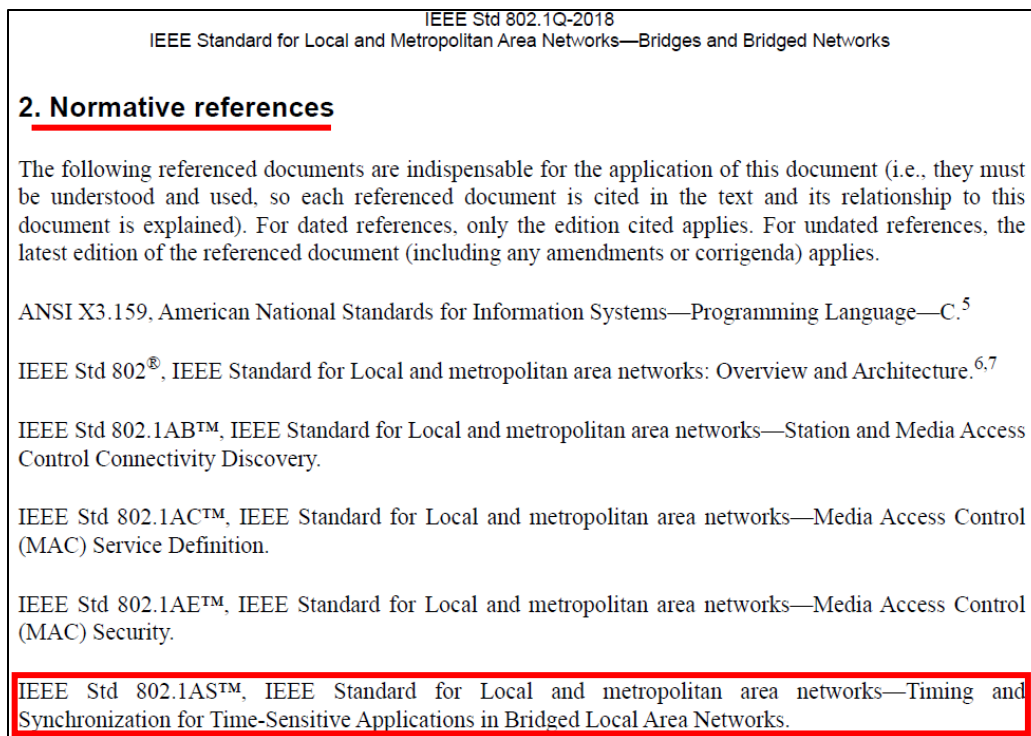

(Source: IEEE Standard for Local and metropolitan area networks— Bridges and Bridged Networks Amendment 25: Enhancements for Scheduled Traffic (IEEE 802.1Qbv-2015))

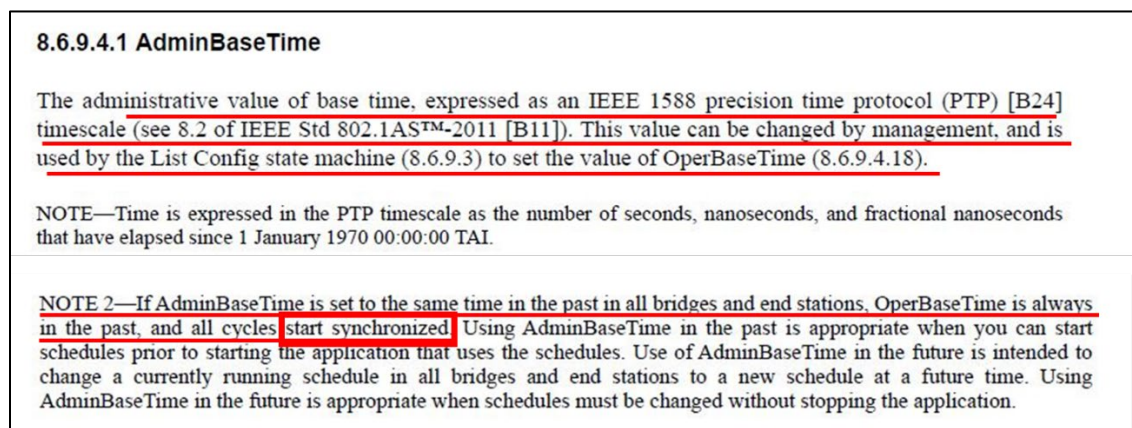

(Source: IEEE Standard for Local and metropolitan area networks— Bridges and Bridged Networks Amendment 25: Enhancements for Scheduled Traffic (IEEE 802.1Qbv-2015))

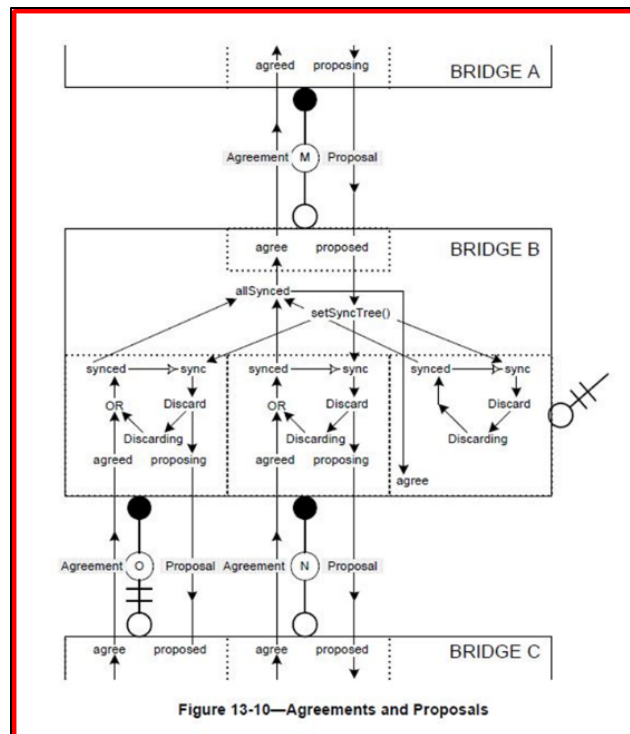

(Source: IEEE Standard for Local and Metropolitan Area Networks—Bridges and Bridged Networks- IEEE Std 802.1Q™-2018)

NOTE 2—Agreements can be generated without prior receipt of a Proposal as soon as the necessary conditions are met. Subsequent receipt of a Proposal serves to elicit a further Agreement. If all other ports have already been synchronized (allSynced in Figure 13-10) and the Proposal's priority vector does not convey worse information, synchronization is maintained and there is no need to transition Designated Ports to Discarding once more, or to transmit further Proposals.

(Source: IEEE Standard for Local and Metropolitan Area Networks—Bridges and Bridged Networks- IEEE Std 802.1Q™-2018)

16. The methods practiced by Analog's use of the accused products include maintaining a substantially synchronized time frame among the plurality of device adapters interconnected by a network, the time frame repeating periodically and including a plurality of

assigned time phases and a free access phase. For example, the accused products are used by Analog to implement the IEEE 802.1Q standard. The time aware bridged LAN uses 802.1AS base time to maintain synchronized time for all the ports in the bridges (device adapters). The bridges containing ports schedule the transmission of traffic based on the synchronized time. Each port associated with a specific set of transmission queues includes a plurality of transmission gates. A transmission gate can be in a closed state or open state. The functionality of assigned time phases is achieved using open gates transmitting data packets during transmission time. The functionality of free access phase is achieved when the gates are opened for transmission during any time. IEEE Std. 802.1Q-2018 supports cyclic queuing and forwarding structures to create synchronized frames and gates which repeat periodically (Annex T).

1.1 Project Number: P802.1Qbv

1.2 Type of Document: Standard

1.3 Life Cycle: Full Use

2.1 Title: Standard for Local and metropolitan area networks--Media Access Control (MAC) Bridges and Virtual Bridged Local Area Networks Amendment: Enhancements for Scheduled Traffic

5.2.b. Scope of the project: This amendment specifies time-aware queue-draining procedures, managed objects and extensions to existing protocols that enable bridges and end stations to schedule the transmission of frames based on a synchronized time. Virtual Local Area Network (VLAN) tag encoded priority values are allocated allowing simultaneous support of scheduled traffic, credit-based shaper traffic and other bridged traffic over Local Area Networks (LANs).

(Source: <http://www.ieee802.org/1/files/public/docs2014/bv-p802-1Qbv-par-modification-1114.pdf>)

- **Grand Master selection**
 - GM-capable stations advertise themselves via ANNOUNCE messages
 - If a station hears from station with “better” clock, it does not send ANNOUNCE
 - Configurable “Priority” field can override clock quality
 - MAC address is tie breaker
 - Time relays drop all inferior ANNOUNCE messages
 - Forward only the best
 - Last one standing is Grand Master for the domain
 - GM is the root of the 802.1AS timing tree
 - GM periodically sends the current time

(Source: <https://avnu.org/wp-content/uploads/2014/05/as-kbstanton-8021AS-tutorial-0714-v01.pdf>)

3.16 PTP End Instance: A PTP Instance that is capable of acting as the source of synchronized time on the network, or destination of synchronized time using the IEEE 802.1AS protocol, or both.

3.17 PTP Instance: A PTP Relay Instance or a PTP End Instance. A PTP Instance implements those portions of this standard indicated as applicable to a PTP Relay Instance or a PTP End Instance. Each PTP Instance operates in exactly one domain.

3.18 PTP Link: Within a domain, a network segment between two PTP Ports using the peer-to-peer delay mechanism of this standard. The peer-to-peer delay mechanism is designed to measure the propagation time over such a link.

NOTE—A PTP Link between PTP Ports of PTP Instances is also a gPTP Communication Path (see 3.9).

3.19 PTP Relay Instance: A PTP Instance that is capable of communicating synchronized time received on one port to other ports, using the IEEE 802.1AS protocol.

NOTE—A PTP Relay Instance could, for example, be contained in a bridge, a router, or a multi-port end station.

(Source: <https://1.ieee802.org/wp-content/uploads/2019/03/802-1AS-rev-d8-0.pdf>)

8.6.8.4 Enhancements for scheduled traffic

A Bridge or an end station may support enhancements that allow transmission from each queue to be scheduled relative to a known timescale. In order to achieve this, a transmission gate is associated with each queue; the state of the transmission gate determines whether or not queued frames can be selected for transmission (see Figure 8-12). For a given queue, the transmission gate can be in one of two states:

- a) Open: Queued frames are selected for transmission, in accordance with the definition of the transmission selection algorithm associated with the queue.
- b) Closed: Queued frames are not selected for transmission.

(Source: IEEE Standard for Local and metropolitan area networks— Bridges and Bridged Networks Amendment 25: Enhancements for Scheduled Traffic (IEEE 802.1Qbv-2015))

8.6.8 Transmission selection

For each Port, frames are selected for transmission on the basis of the traffic classes that the Port supports and the operation of the transmission selection algorithms supported by the corresponding queues on that Port. For a given Port and traffic class, frames are selected from the corresponding queue for transmission if and only if

- a) The operation of the transmission selection algorithm supported by that queue determines that there is a frame available for transmission; and
- b) For each queue corresponding to a numerically higher value of traffic class supported by the Port, the operation of the transmission selection algorithm supported by that queue determines that there is no frame available for transmission.

(Source: IEEE Standard for Local and Metropolitan Area Networks—Bridges and Bridged Networks- IEEE Std 802.1Q™-2018)

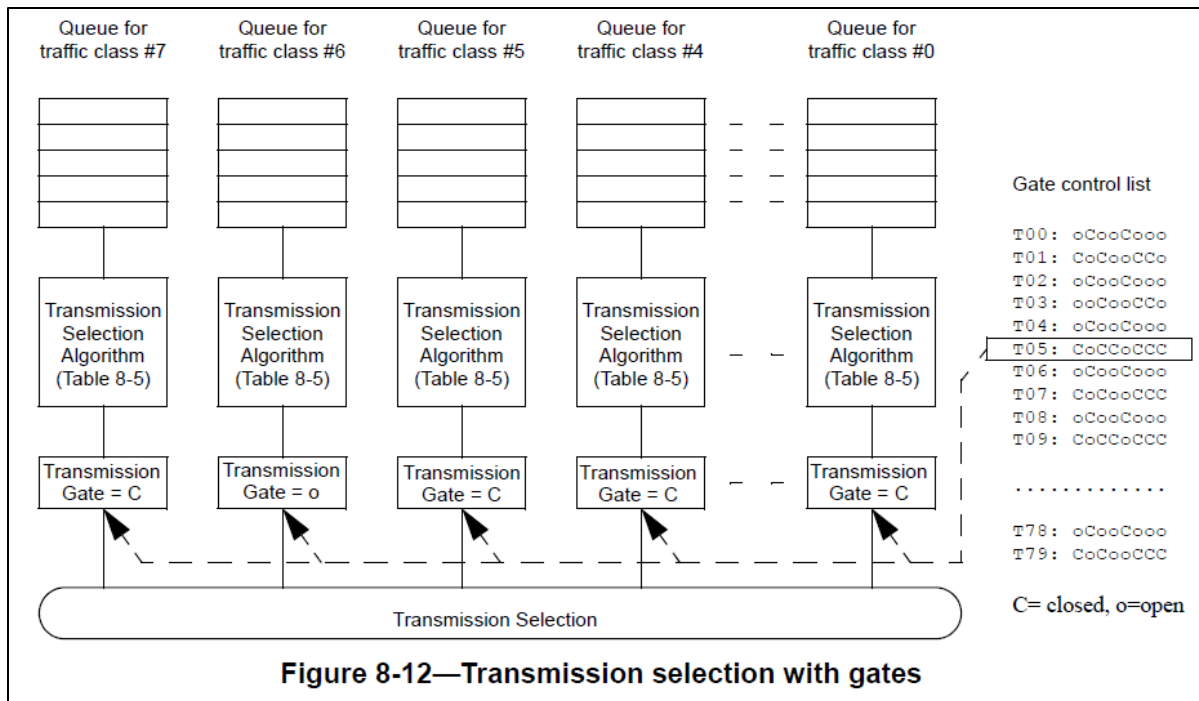

(Source: IEEE Standard for Local and metropolitan area networks— Bridges and Bridged Networks Amendment 25: Enhancements for Scheduled Traffic (IEEE 802.1Qbv-2015))

A gate control list associated with each Port contains an ordered list of gate operations. Each gate operation changes the transmission gate state for the gate associated with each of the Port's traffic class queues. In an implementation that does not support enhancements for scheduled traffic, all gates are assumed to be permanently in the open state. Table 8-6 identifies the gate operation types, their parameters, and the actions that result from their execution. The state machines that control the execution of the gate control list, along with their variables and procedures, are specified in 8.6.9.

(Source: IEEE Standard for Local and metropolitan area networks— Bridges and Bridged Networks Amendment 25: Enhancements for Scheduled Traffic (IEEE 802.1Qbv-2015))

3.3 gating cycle: The period of time over which the sequence of operations in a gate control list repeats.

3.4 transmission gate: A gate that connects or disconnects the transmission selection function of the forwarding process from the queue, allowing or preventing it from selecting frames from that queue. The gate has two states, Open and Closed.

(Source: IEEE Standard for Local and metropolitan area networks— Bridges and Bridged Networks Amendment 25: Enhancements for Scheduled Traffic (IEEE 802.1Qbv-2015))

Cyclic queuing and forwarding⁵³

T.1 Overview of CQF

Cyclic queuing and forwarding (CQF) is a method of traffic shaping that can deliver deterministic, and easily calculated, latency for time-sensitive traffic streams. As the name implies, the principle underlying CQF is that stream traffic is transmitted and queued for transmission along a network path in a cyclic manner. Time is divided into numbered time intervals $i, i+1, i+2, \dots, i+N$, each of duration d . Frames transmitted by a Bridge, *Alice*, during time interval i are received by a downstream Bridge, *Bob*, during time interval i and are transmitted onwards by *Bob* towards Bridge *Charlie* during time interval $i+1$, and so on. A starting assumption is that, for a given traffic class, all Bridges and all end stations connected to a given bridge have a common understanding (to a known accuracy) of the start time of cycle i , and the cycle duration, d .

Frames transmitted by *Alice* during interval i are transmitted by *Bob* in interval $i+1$; the maximum possible delay experienced by a given frame is from the beginning of i to the end of $i+1$, or twice d . Similarly, the minimum possible delay experienced is from the end of i to the beginning of $i+1$, which is zero. More generally, the maximum delay experienced by a given frame is

$$(h+1) \times d$$

and the minimum delay experienced by a given frame is

$$(h-1) \times d$$

where h is the number of hops.

(Source: IEEE Standard for Local and Metropolitan Area Networks—Bridges and Bridged Networks- IEEE Std 802.1Q™-2018)

17. The methods practiced by Analog's use of the accused products include assigning each time phase to a specific device adapter prior to transmission of real-time data by the specific device adapter. For example, the accused products are used by Analog to implement the IEEE 802.1Q standard. IEEE standard 802.1Q shows that scheduling (assigning) of transmission gates starts prior to the transmission of real-time data. Per clause 8.6.8 of the IEEE Std. 802.1Q, each time phase is assigned to a specific device adapter prior to transmission of real-time data by the specific device adapter. IEEE 802.1Q performs traffic shaping through Per-Stream Filtering and Policing (PSTP).

NOTE 2—If AdminBaseTime is set to the same time in the past in all bridges and end stations. OperBaseTime is always in the past, and all cycles start synchronized. Using AdminBaseTime in the past is appropriate when you can start schedules prior to starting the application that uses the schedules. Use of AdminBaseTime in the future is intended to

(Source: IEEE Standard for Local and metropolitan area networks— Bridges and Bridged Networks Amendment 25: Enhancements for Scheduled Traffic (IEEE 802.1Qbv-2015))

1.1 Project Number: P802.1Qbv
1.2 Type of Document: Standard
1.3 Life Cycle: Full Use

5.5 Need for the Project: The credit-based shaper works well in arbitrary networks (i.e., non-engineered). Networks employing scheduled transmissions are able to control real-time processes. This amendment enables those two kinds of networks to be consolidated into a single network, with a significant cost reduction to the user.

(Source: <http://www.ieee802.org/1/files/public/docs2014/bv-p802-1Qbv-par-modification-1114.pdf>)

8.6.8 Transmission selection

For each Port, frames are selected for transmission on the basis of the traffic classes that the Port supports and the operation of the transmission selection algorithms supported by the corresponding queues on that Port. For a given Port and traffic class, frames are selected from the corresponding queue for transmission if and only if

- The operation of the transmission selection algorithm supported by that queue determines that there is a frame available for transmission; and
- For each queue corresponding to a numerically higher value of traffic class supported by the Port, the operation of the transmission selection algorithm supported by that queue determines that there is no frame available for transmission.

(Source: IEEE Standard for Local and Metropolitan Area Networks—Bridges and Bridged Networks- IEEE Std 802.1Q™-2018)

5.4.1.9 Cyclic queuing and forwarding (CQF) requirements

A VLAN Bridge component implementation that conforms to the provisions of this standard for CQF (see Annex T) shall

- Support the enhancements for scheduled traffic as specified in 8.6.8.4.
- Support the state machines for scheduled traffic as specified in 8.6.9.
- Support the state machines for stream gate control as specified in 8.6.10.
- Support the management entities for scheduled traffic as specified in 12.29.
- Support the requirements for per-stream filtering and policing (PSFP) as stated in 5.4.1.8.
- Support the management entities for PSFP as specified in 12.31.

(Source: IEEE Standard for Local and Metropolitan Area Networks—Bridges and Bridged Networks- IEEE Std 802.1Q™-2018)

5.4.1.5 Forwarding and Queuing Enhancements for time-sensitive streams (FQTSS)—requirements

A VLAN Bridge component implementation that conforms to the provisions of this standard for FQTSS shall

- a) Support a minimum of two traffic classes on all Ports, of which
 - 1) A minimum of one traffic class supports the strict priority algorithm for transmission selection (8.6.8.1), and
 - 2) One traffic class is a stream reservation (SR) class.
- b) Support the operation of the credit-based shaper algorithm (8.6.8.2) on all Ports as the transmission selection algorithm used for the SR class.
- c) Support SRP domain boundary port priority regeneration override as defined in 6.9.4, and the default priority regeneration override value defined in Table 6-5, for SR class “B.”
- d) Support the tables and procedures for mapping priorities to traffic classes as defined in 34.5.

SR: Stream Reservation, SRP: Stream Reservation Protocol

(Source: IEEE Standard for Local and Metropolitan Area Networks—Bridges and Bridged Networks- IEEE Std 802.1Q™-2018)

18. The plurality of device adaptors recited above in connection with Analog’s use of the accused products includes a respective one of the plurality of device adaptors that is configured to transmit data during at least one of a respective assigned time phase or the free access phase, to refrain from transmitting data during time phases not assigned to the respective one of the plurality of device adaptors, and to determine whether to defer transmission of data during at least one of the assigned time phase or the free access phase to allow a non-real time device to transmit data. For example, the accused products are used by Analog to implement the IEEE 802.1Q standard. IEEE standard 802.1Q implements a method in which open gates transmit data packets during transmission time and closed gates refrain data packets from transmission. The functionality of assigned time phases is achieved using open gates transmitting data packets during transmission time. The functionality of free access phase is achieved by the gates that are opened for transmission during any time. IEEE Std. 802.1Q supports Forwarding and Queuing Enhancements for Time Sensitive Streams. Thus, one of the plurality of device adaptors is configured to transmit data during at least one of a respective assigned time phase or

free access phase, to refrain from transmitting data during time phases not assigned to the respective one of the plurality of device adapters. IEEE Std. 802.1Q provides traffic shaping for various classes of data transmission and determining whether to defer transmission of data during at least one of the assigned time phase or the free access phase to allow a non-real time device to transmit data.

8.6.8.4 Enhancements for scheduled traffic

A Bridge or an end station may support enhancements that allow transmission from each queue to be scheduled relative to a known timescale. In order to achieve this, a transmission gate is associated with each queue; the state of the transmission gate determines whether or not queued frames can be selected for transmission (see Figure 8-12). For a given queue, the transmission gate can be in one of two states:

- a) *Open*: Queued frames are selected for transmission, in accordance with the definition of the transmission selection algorithm associated with the queue.
- b) *Closed*: Queued frames are not selected for transmission.

(Source: IEEE Standard for Local and metropolitan area networks— Bridges and Bridged Networks Amendment 25: Enhancements for Scheduled Traffic (IEEE 802.1Qbv-2015))

A *gate control list* associated with each Port contains an ordered list of gate operations. Each gate operation changes the transmission gate state for the gate associated with each of the Port's traffic class queues. In an implementation that does not support enhancements for scheduled traffic, all gates are assumed to be permanently in the *open* state. Table 8-6 identifies the gate operation types, their parameters, and the actions that result from their execution. The state machines that control the execution of the gate control list, along with their variables and procedures, are specified in 8.6.9.

(Source: IEEE Standard for Local and metropolitan area networks— Bridges and Bridged Networks Amendment 25: Enhancements for Scheduled Traffic (IEEE 802.1Qbv-2015))

5.4.1.5 Forwarding and Queuing Enhancements for time-sensitive streams (FQTSS)—requirements

A VLAN Bridge component implementation that conforms to the provisions of this standard for FQTSS shall

- a) Support a minimum of two traffic classes on all Ports, of which
 - 1) A minimum of one traffic class supports the strict priority algorithm for transmission selection (8.6.8.1), and
 - 2) One traffic class is a stream reservation (SR) class.
- b) Support the operation of the credit-based shaper algorithm (8.6.8.2) on all Ports as the transmission selection algorithm used for the SR class.
- c) Support SRP domain boundary port priority regeneration override as defined in 6.9.4, and the default priority regeneration override value defined in Table 6-5, for SR class “B.”
- d) Support the tables and procedures for mapping priorities to traffic classes as defined in 34.5.

SR: Stream Reservation, SRP: Stream Reservation Protocol

(Source: IEEE Standard for Local and Metropolitan Area Networks—Bridges and Bridged Networks- IEEE Std 802.1Q™-2018)

5.4.1.6 ETS Bridge requirements

A device supporting ETS shall

- a) Support at least 3 traffic classes (37.3).

NOTE—A minimum of 3 traffic classes allows a minimum configuration such that one traffic class contains priorities with PFC enabled, one traffic class contains priorities with PFC disabled, and one traffic class using strict priority.

- b) Support bandwidth configuration with a granularity of 1% or finer (37.3).
- c) Support bandwidth allocation with a precision of 10% (37.3).
- d) Support a transmission selection policy such that if one of the traffic classes does not consume its allocated bandwidth, then any unused bandwidth is available to other traffic classes (37.3).
- e) Support DCBX (Clause 38).

(Source: IEEE Standard for Local and Metropolitan Area Networks—Bridges and Bridged Networks- IEEE Std 802.1Q™-2018)

19. Analog has had knowledge of the ‘053 Patent at least as of the date when it was notified of the filing of this action.

20. Far North Patents has been damaged as a result of the infringing conduct by Analog alleged above. Thus, Analog is liable to Far North Patents in an amount that adequately compensates it for such infringements, which, by law, cannot be less than a reasonable royalty, together with interest and costs as fixed by this Court under 35 U.S.C. § 284.

21. Far North Patents and/or its predecessors-in-interest have satisfied all statutory obligations required to collect pre-filing damages for the full period allowed by law for infringement of the '053 Patent.

COUNT II

DIRECT INFRINGEMENT OF U.S. PATENT NO. 6,246,702

22. On June 12, 2001, United States Patent No. 6,246,702 (“the ‘702 Patent”) was duly and legally issued by the United States Patent and Trademark Office for an invention entitled “Methods and Apparatus for Providing Quality-of-Service Guarantees in Computer Networks.”

23. Far North Patents is the owner of the ‘702 Patent, with all substantive rights in and to that patent, including the sole and exclusive right to prosecute this action and enforce the ‘702 Patent against infringers, and to collect damages for all relevant times.

24. Analog made, had made, used, imported, provided, supplied, distributed, sold, and/or offered for sale products and/or systems including, for example, its Analog Fido5000 REM switch family (5100/5200) and its Analog EVAL-RapID-TSNEK TSN Evaluation Kit families of products that include advanced quality of service capabilities (collectively, “accused products”).

Industrial Ethernet Embedded Switches

REM Switch Family Supports All Major Industrial Ethernet Protocols and Connects to Any Processor to Build Any Field Device or Controller Application.

The fido5000 REM switch family includes two 2-port, Industrial Ethernet embedded switches that interface to any processor, including any ARM® CPU and ADI's fido1100 communication controller. ADI's PriorityChannel™ technology has been integrated into their hardware architecture and designed into the REM switch software drivers. The protocols supported by these switches are PROFINET Class C (IRT) and Class B (RT), EtherNet/IP® with and without DLR, Modbus® TCP, EtherCAT®, and POWERLINK®. The REM switches come with a software driver for each protocol. The software drivers provide an API for integration with any field device or controller protocol stack. ADI is certifying REM and its software drivers at each protocol's sponsoring industry organization using ADI's Rapid platform.



fido5100 data sheet, specs and more



fido5200 data sheet, specs, and more

(Source : <https://www.analog.com/en/products/industrial-ethernet/industrial-ethernet-embedded-switches.html>)

Embedded Switches

	Port Count	Protocol Support	TSN Features	Package	Power
fido5100	2	PROFINET, Ethernet/IP®, POWERLINK®, Modbus® TCP	802.1AS (Time synchronization); 802.1Qbv (Scheduled traffic); 802.1CB (Redundancy); 802.1Qcc (Configuration)	144-ball, 10 mm × 10 mm CSP_BGA	160 mW
fido5200	2	EtherCAT®, PROFINET, Ethernet/IP, POWERLINK, Modbus TCP	802.1AS (Time synchronization); 802.1Qbv (Scheduled traffic); 802.1CB (Redundancy); 802.1Qcc (Configuration)	144-ball, 10 mm × 10 mm CSP_BGA	160 mW

(Source : screenshot of PDF downloaded from <https://www.analog.com/media/en/news-marketing-collateral/solutions-bulletins-brochures/scalable-ethernet-timed-to-perfection.pdf>)

(Source : <https://www.analog.com/en/design-center/evaluation-hardware-and-software/evaluation-boards-kits/eval-rapid-tsnek.html#eb-overview>)

Product Details

The TSN Evaluation Kit is configured to provide TSN Gateway functionality in order to quickly assess TSN features and capabilities and better understand how TSN works. From there, it is possible to utilize fido5000 Real-time Ethernet Multi-protocol (REM) Switch chip to provide a TSN solution in your product's application. The figure below shows how the TSN Kit architecture relates to a "partitioned" communication architecture and to an "integrated" communications architecture.

Using the TSN gateway functionality allows a non-TSN device to participate in a TSN network without implementing TSN-specific features natively. The TSN gateway has built-in features from the following IEEE specifications:

- 802.1AS, AS-REV – Time Synchronization
- 802.1Qbv – Scheduled Traffic
- 802.1Qci – Ingress Policing
- 802.1CB – Seamless Redundancy
- 802.1Qcc – Stream Reservation Protocol
- 802.1Qbu / 802.3br – Preemption

The TSN gateway comes pre-installed with software that supports 802.1AS, 802.1Qbv, 802.1Qcc, and stream translation. Software updates will be provided to add TSN features and correct any interoperability issues. 802.1Qcc is currently implemented using a webserver, but will ultimately be implemented so the gateway can be configured by a Central Network Controller (CNC).

(Source : <https://www.analog.com/en/design-center/evaluation-hardware-and-software/evaluation-boards-kits/eval-rapid-tsnek.html#eb-overview>)

25. By doing so, Analog has directly infringed (literally and/or under the doctrine of equivalents) at least Claim 27 of the '702 Patent.

26. Analog has infringed the '702 Patent by using the accused products and thereby practicing a method for regulating traffic in an Ethernet network including real-time devices, non-real-time devices, a network medium, and a plurality of device adapters connected between the devices and the network medium, each of the device adapters including a clock. For example, the accused products are used by Analog to implement the IEEE 802.1Q standard. IEEE standard 802.1Q (Qbv) implements a method for scheduling traffic in time aware Local Area Network (Ethernet network). The time aware network includes multiple end points (devices) and bridges that includes ports (device adapters). The endpoint and bridges are connected via interconnects (network medium). Also, each time aware bridge including port is a boundary clock. The endpoints transmit data that is a mix of time-critical traffic and other traffic, i.e., real time data and non-real time data. The end point is either a real time device or a non-real time device. IEEE Std. 802.1AS™ is normative and essential to implement an IEEE Std. 802.1Q Compliant System.

1.1 Project Number: P802.1Qbv
1.2 Type of Document: Standard
1.3 Life Cycle: Full Use

2.1 Title: Standard for Local and metropolitan area networks--Media Access Control (MAC) Bridges and Virtual Bridged Local Area Networks Amendment: Enhancements for Scheduled Traffic

5.2.b. Scope of the project: This amendment specifies time-aware queue-draining procedures, managed objects and extensions to existing protocols that enable bridges and end stations to schedule the transmission of frames based on a synchronized time. Virtual Local Area Network (VLAN) tag encoded priority values are allocated allowing simultaneous support of scheduled traffic, credit-based shaper traffic and other bridged traffic over Local Area Networks (LANs).

(Source: <http://www.ieee802.org/1/files/public/docs2014/bv-p802-1Qbv-par-modification-1114.pdf>)

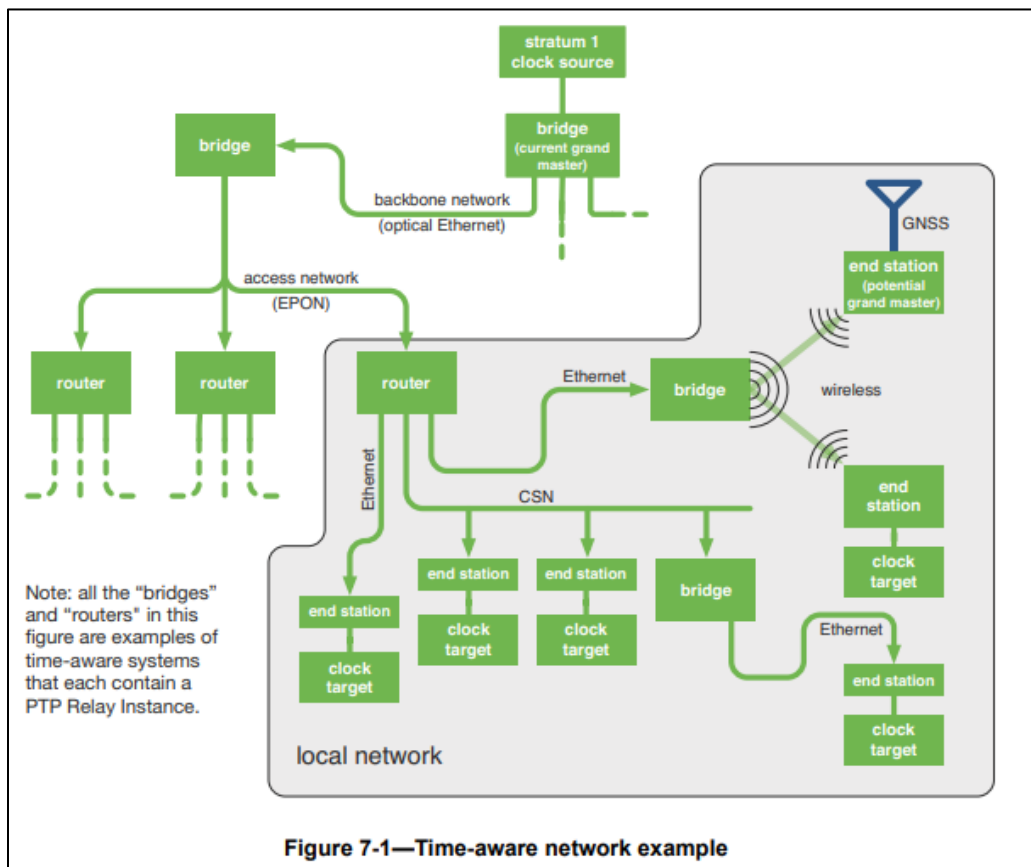

(Source: <https://1.ieee802.org/wp-content/uploads/2019/03/802-1AS-rev-d8-0.pdf>)

7.2 Architecture of a time-aware network

7.2.1 General

A time-aware network consists of a number of interconnected time-aware systems that support the gPTP defined within this standard. These time-aware systems can be any networking device, including, for example, bridges, routers, and end stations. A set of time-aware systems that are interconnected by gPTP-capable network elements is called a gPTP network. Each instance of gPTP that the time-aware systems support is in one gPTP domain, and the instances of gPTP are said to be part of that gPTP domain. A time-aware system can support, and therefore be part of, more than one gPTP domain. The entity of a single time-aware system that executes gPTP in one gPTP domain is called a PTP Instance. A time-aware system can contain multiple PTP Instances, which are each associated with a different gPTP domain. There are two

(Source: <https://1.ieee802.org/wp-content/uploads/2019/03/802-1AS-rev-d8-0.pdf>)

- c) In gPTP there are only two types of PTP Instances: PTP End Instances and PTP Relay Instances, while IEEE 1588 has ordinary clocks, boundary clocks, end-to-end transparent clocks, and P2P transparent clocks. A PTP End Instance corresponds to an IEEE 1588 ordinary clock, and a PTP Relay Instance is a type of IEEE 1588 boundary clock where its operation is very tightly defined, so much so that a PTP Relay Instance with Ethernet ports can be shown to be mathematically equivalent to a P2P transparent clock in terms of how synchronization is performed, as shown in

(Source: <https://1.ieee802.org/wp-content/uploads/2019/03/802-1AS-rev-d8-0.pdf>)

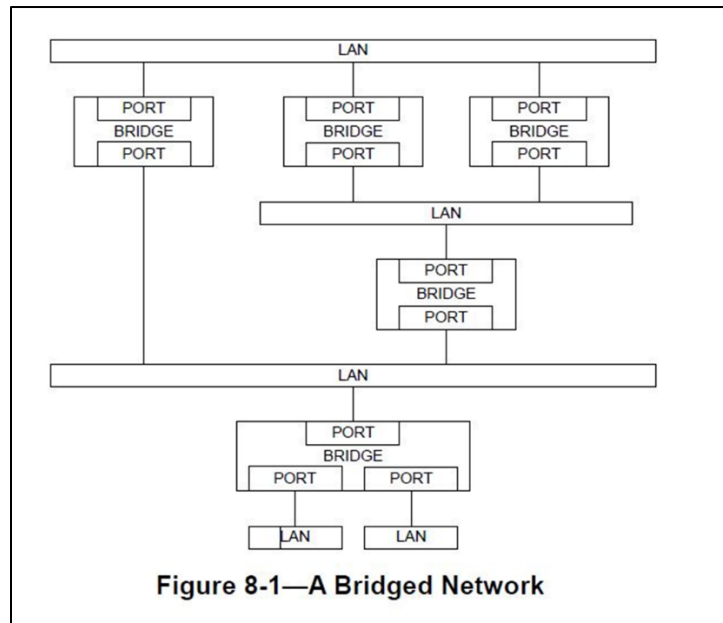

(Source: IEEE Standard for Local and Metropolitan Area Networks—Bridges and Bridged Networks- IEEE Std 802.1Q™-2018)

Traffic scheduling

This annex provides some background to the mechanisms provided in this standard for traffic scheduling, with the intent of providing some insight into the motivation for the provision of mechanisms for traffic scheduling and some of the ways that the mechanisms might be used.

Q.1 Motivation

Some applications have a need for frame delivery that is highly predictable in terms of the time at which frame transmission will occur, and the overall latency and jitter that will be experienced as the frame is propagated to its destination. Examples include industrial and automotive control applications, where data transmitted over the network is used to feed the parameters of control loops that are critical to the operation of the plant or machinery involved, and where frames carrying control data are transmitted on a repeating time schedule; late delivery of such frames can result in instability, inaccuracy, or failure of the operation of the control loops concerned. In some implementations, this need has been met by the provision of dedicated, highly engineered networks that are used solely for the transmission of time-critical control traffic; however, as the bandwidth occupied by such traffic is often low, and the cost of providing a dedicated control network can be high, it can be desirable to mix time-critical traffic with other classes of traffic in the same network, as long as such mixing can be achieved while still meeting the timing requirements of the time-critical traffic.

(Source: IEEE Standard for Local and metropolitan area networks— Bridges and Bridged Networks Amendment 25: Enhancements for Scheduled Traffic (IEEE 802.1Qbv-2015))

IEEE Std 802.1Q-2018 IEEE Standard for Local and Metropolitan Area Networks—Bridges and Bridged Networks
<h2><u>2. Normative references</u></h2> <p>The following referenced documents are indispensable for the application of this document (i.e., they must be understood and used, so each referenced document is cited in the text and its relationship to this document is explained). For dated references, only the edition cited applies. For undated references, the latest edition of the referenced document (including any amendments or corrigenda) applies.</p> <p>ANSI X3.159, American National Standards for Information Systems—Programming Language—C.⁵</p> <p>IEEE Std 802[®], IEEE Standard for Local and metropolitan area networks: Overview and Architecture.^{6,7}</p> <p>IEEE Std 802.1AB[™], IEEE Standard for Local and metropolitan area networks—Station and Media Access Control Connectivity Discovery.</p> <p>IEEE Std 802.1AC[™], IEEE Standard for Local and metropolitan area networks—Media Access Control (MAC) Service Definition.</p> <p>IEEE Std 802.1AE[™], IEEE Standard for Local and metropolitan area networks—Media Access Control (MAC) Security.</p> <p><u>IEEE Std 802.1AS[™], IEEE Standard for Local and metropolitan area networks—Timing and Synchronization for Time-Sensitive Applications in Bridged Local Area Networks.</u></p>

(Source: IEEE Standard for Local and Metropolitan Area Networks—Bridges and Bridged Networks- IEEE Std 802.1Q™-2018)

27. The methods practiced by Analog's use of the accused products include defining a common time reference for the device adapters, said common time reference including a frame of time having a plurality of time phases, each of device adapters being uniquely assigned to one of said plurality of time phases, said plurality of time phases including a free-access phase. For example, the accused products are used by Analog to implement the IEEE 802.1Q standard. The time aware bridged LAN use 802.1AS base time to maintain synchronized time (common time reference) for all the ports in the bridges (device adapters). The bridges containing ports schedule the transmission of traffic based on the synchronized time. Each port associated with a specific set of transmission queues includes a plurality of transmission gates. A transmission gate can be in a closed state or open state. The functionality of assigned time phases is achieved using open gates transmitting data packets during transmission time. The functionality of free access phase is achieved when the gates are opened for transmission during any time.

1.1 Project Number: P802.1Qbv

1.2 Type of Document: Standard

1.3 Life Cycle: Full Use

2.1 Title: Standard for Local and metropolitan area networks--Media Access Control (MAC) Bridges and Virtual Bridged Local Area Networks Amendment: Enhancements for Scheduled Traffic

5.2.b. Scope of the project: This amendment specifies time-aware queue-draining procedures, managed objects and extensions to existing protocols that enable bridges and end stations to schedule the transmission of frames based on a synchronized time. Virtual Local Area Network (VLAN) tag encoded priority values are allocated allowing simultaneous support of scheduled traffic, credit-based shaper traffic and other bridged traffic over Local Area Networks (LANs).

(Source: <http://www.ieee802.org/1/files/public/docs2014/bv-p802-1Qbv-par-modification-1114.pdf>)

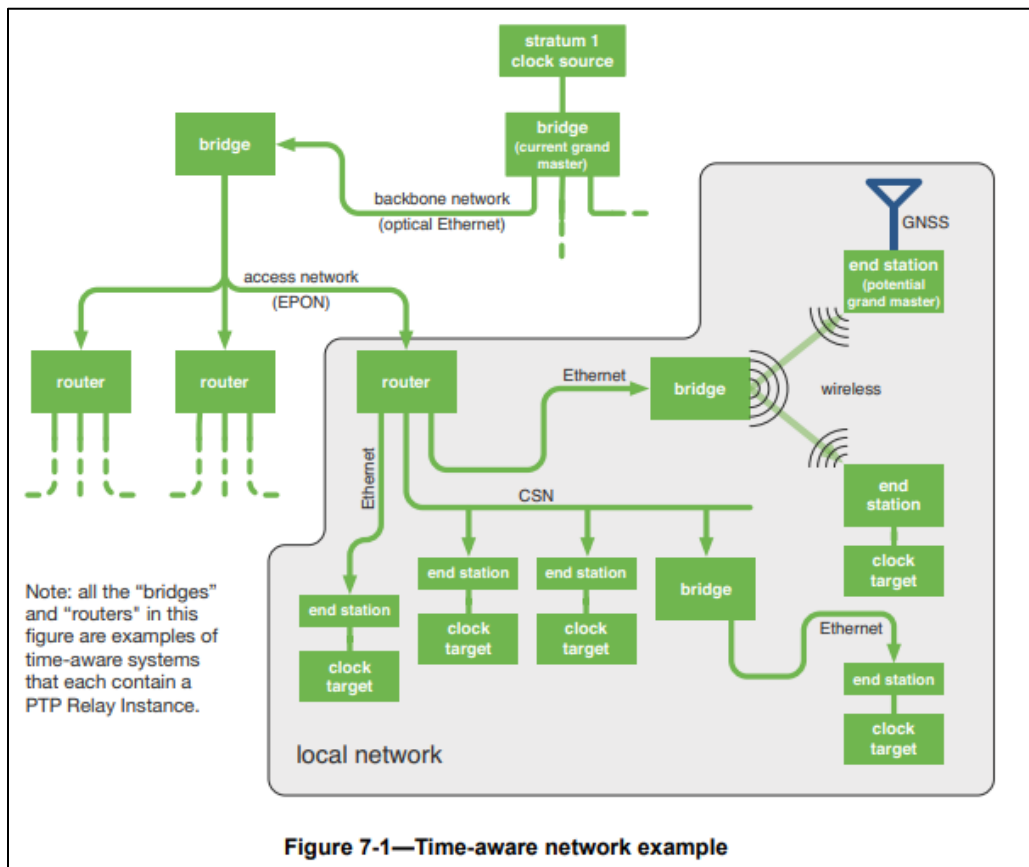

(Source: <https://1.ieee802.org/wp-content/uploads/2019/03/802-1AS-rev-d8-0.pdf>)

3.16 PTP End Instance: A PTP Instance that is capable of acting as the source of synchronized time on the network, or destination of synchronized time using the IEEE 802.1AS protocol, or both.

3.17 PTP Instance: A PTP Relay Instance or a PTP End Instance. A PTP Instance implements those portions of this standard indicated as applicable to a PTP Relay Instance or a PTP End Instance. Each PTP Instance operates in exactly one domain.

3.18 PTP Link: Within a domain, a network segment between two PTP Ports using the peer-to-peer delay mechanism of this standard. The peer-to-peer delay mechanism is designed to measure the propagation time over such a link.

NOTE—A PTP Link between PTP Ports of PTP Instances is also a gPTP Communication Path (see 3.9).

3.19 PTP Relay Instance: A PTP Instance that is capable of communicating synchronized time received on one port to other ports, using the IEEE 802.1AS protocol.

NOTE—A PTP Relay Instance could, for example, be contained in a bridge, a router, or a multi-port end station.

(Source: <https://1.ieee802.org/wp-content/uploads/2019/03/802-1AS-rev-d8-0.pdf>)

8.6.8.4 Enhancements for scheduled traffic

A Bridge or an end station may support enhancements that allow transmission from each queue to be scheduled relative to a known timescale. In order to achieve this, a transmission gate is associated with each queue; the state of the transmission gate determines whether or not queued frames can be selected for transmission (see Figure 8-12). For a given queue, the transmission gate can be in one of two states:

- a) Open: Queued frames are selected for transmission, in accordance with the definition of the transmission selection algorithm associated with the queue.
- b) Closed: Queued frames are not selected for transmission.

(Source: IEEE Standard for Local and metropolitan area networks— Bridges and Bridged Networks Amendment 25: Enhancements for Scheduled Traffic (IEEE 802.1Qbv-2015))

8.6.8 Transmission selection

For each Port, frames are selected for transmission on the basis of the traffic classes that the Port supports and the operation of the transmission selection algorithms supported by the corresponding queues on that Port. For a given Port and traffic class, frames are selected from the corresponding queue for transmission if and only if

- a) The operation of the transmission selection algorithm supported by that queue determines that there is a frame available for transmission; and
- b) For each queue corresponding to a numerically higher value of traffic class supported by the Port, the operation of the transmission selection algorithm supported by that queue determines that there is no frame available for transmission.

(Source: IEEE Standard for Local and Metropolitan Area Networks—Bridges and Bridged Networks- IEEE Std 802.1Q™-2018)

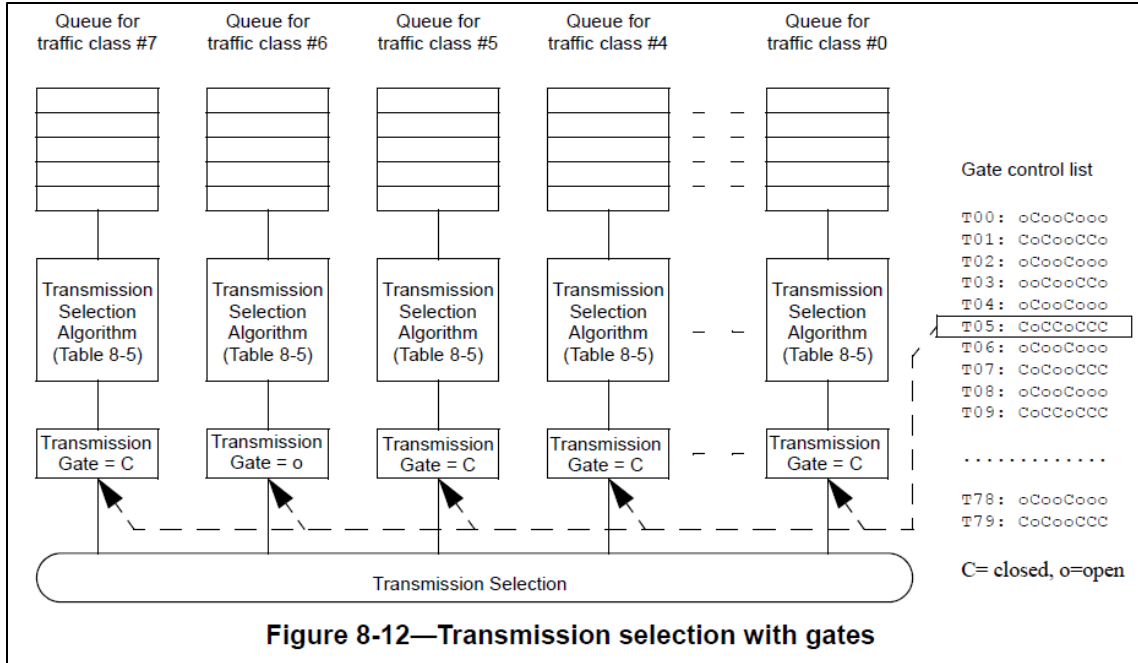

(Source: IEEE Standard for Local and metropolitan area networks— Bridges and Bridged Networks Amendment 25: Enhancements for Scheduled Traffic (IEEE 802.1Qbv-2015))

A gate control list associated with each Port contains an ordered list of gate operations. Each gate operation changes the transmission gate state for the gate associated with each of the Port’s traffic class queues. In an implementation that does not support enhancements for scheduled traffic, all gates are assumed to be permanently in the open state. Table 8-6 identifies the gate operation types, their parameters, and the actions that result from their execution. The state machines that control the execution of the gate control list, along with their variables and procedures, are specified in 8.6.9.

(Source: IEEE Standard for Local and metropolitan area networks— Bridges and Bridged Networks Amendment 25: Enhancements for Scheduled Traffic (IEEE 802.1Qbv-2015))

28. The methods practiced by Analog’s use of the accused products include allowing a device adapter to transmit packets during said time phase uniquely assigned thereto and during said free-access phase. For example, the accused products are used by Analog to implement the IEEE 802.1Q standard. The open gates assigned to the transmission queue of a port (device adapter) transmit the data packets during the transmission time. The transmission selection algorithm determines the transmission time. If the gates are in permanent open state, the data packets are transmitted from the gates during any time. The functionality of assigned time phases

is achieved using open gates transmitting data packets during transmission time. The functionality of free access phase is achieved when the gates are permanently opened for transmission during any time.

8.6.8.4 Enhancements for scheduled traffic

A Bridge or an end station may support enhancements that allow transmission from each queue to be scheduled relative to a known timescale. In order to achieve this, a transmission gate is associated with each queue; the state of the transmission gate determines whether or not queued frames can be selected for transmission (see Figure 8-12). For a given queue, the transmission gate can be in one of two states:

- a) Open: Queued frames are selected for transmission, in accordance with the definition of the transmission selection algorithm associated with the queue.
- b) Closed: Queued frames are not selected for transmission.

(Source: IEEE Standard for Local and metropolitan area networks— Bridges and Bridged Networks Amendment 25: Enhancements for Scheduled Traffic (IEEE 802.1Qbv-2015))

3.4 transmission gate: A gate that connects or disconnects the transmission selection function of the forwarding process from the queue, allowing or preventing it from selecting frames from that queue. The gate has two states, Open and Closed.

(Source: IEEE Standard for Local and metropolitan area networks— Bridges and Bridged Networks Amendment 25: Enhancements for Scheduled Traffic (IEEE 802.1Qbv-2015))

A gate control list associated with each Port contains an ordered list of gate operations. Each gate operation changes the transmission gate state for the gate associated with each of the Port's traffic class queues. In an implementation that does not support enhancements for scheduled traffic, all gates are assumed to be permanently in the open state. Table 8-6 identifies the gate operation types, their parameters, and the actions that result from their execution. The state machines that control the execution of the gate control list, along with their variables and procedures, are specified in 8.6.9.

(Source: IEEE Standard for Local and metropolitan area networks— Bridges and Bridged Networks Amendment 25: Enhancements for Scheduled Traffic (IEEE 802.1Qbv-2015))

29. The methods practiced by Analog's use of the accused products include designating one of said device adapters as a master timing device. For example, the accused products are used by Analog to implement the IEEE 802.1Q standard. The ports of the time

aware bridge (device adapter) uses best master clock algorithm (BMCA) to determine a potential grandmaster port (master timing device).

7.2.2 Time-aware network consisting of a single gPTP domain

Figure 7-1 illustrates an example time-aware network consisting of a single gPTP domain, using all the above network technologies (i.e., (c) - (f) of 7.2.1), where end stations on several local networks are connected to a grandmaster on a backbone network via an EPON access network.

Any PTP Instance with clock sourcing capabilities can be a potential grandmaster, so there is a selection method (the *best master clock algorithm*, or BMCA) that ensures that all of the PTP Instances in a gPTP domain use the same grandmaster.¹² The BMCA is largely identical to that used in IEEE Std 1588-2019,

(Source: <https://1.ieee802.org/wp-content/uploads/2019/03/802-1AS-rev-d8-0.pdf>)

10.3.1.1 Best master clock algorithm overview

In the BMCA (i.e., method (a) of 10.3.1), best master selection information is exchanged between PTP Instances of time-aware systems via Announce messages (see 10.5 and 10.6). Each Announce message contains time-synchronization spanning tree vector information that identifies one PTP Instance as the root of the time-synchronization spanning tree and, if the PTP Instance is grandmaster-capable, the grandmaster. Each PTP Instance in turn uses the information contained in the Announce messages it receives, along with its knowledge of itself, to compute which of the PTP Instances that it has knowledge of ought to be the root of the spanning tree and, if grandmaster-capable, the grandmaster. As part of constructing the time-synchronization spanning tree, each port of each PTP Instance is assigned a port state from Table 10-2 by state machines associated with the ports and with the PTP Instance as a whole.

(Source: <https://1.ieee802.org/wp-content/uploads/2019/03/802-1AS-rev-d8-0.pdf>)

11.1.3 Transport of time-synchronization information

The transport of time-synchronization information by a PTP Instance, using Sync and Follow_Up (or just Sync) messages, is illustrated in Figure 11-2. The mechanism is mathematically equivalent to the mechanism described in IEEE Std 1588-2019 for a peer-to-peer transparent clock that is synchronized (see 11.4.5.1, 11.5.1, and 11.5.2.2 of IEEE Std 1588-2019). However, as will be seen shortly, the processes of transporting synchronization by a peer-to-peer transparent clock that is synchronized and by a boundary clock are mathematically and functionally equivalent. The main functional difference between the two types of clocks is that the boundary clock participates in best master selection and invokes the BMCA, while the peer-to-peer transparent clock does not participate in best master selection and does not invoke the BMCA (and implementations of the two types of clocks can be different).

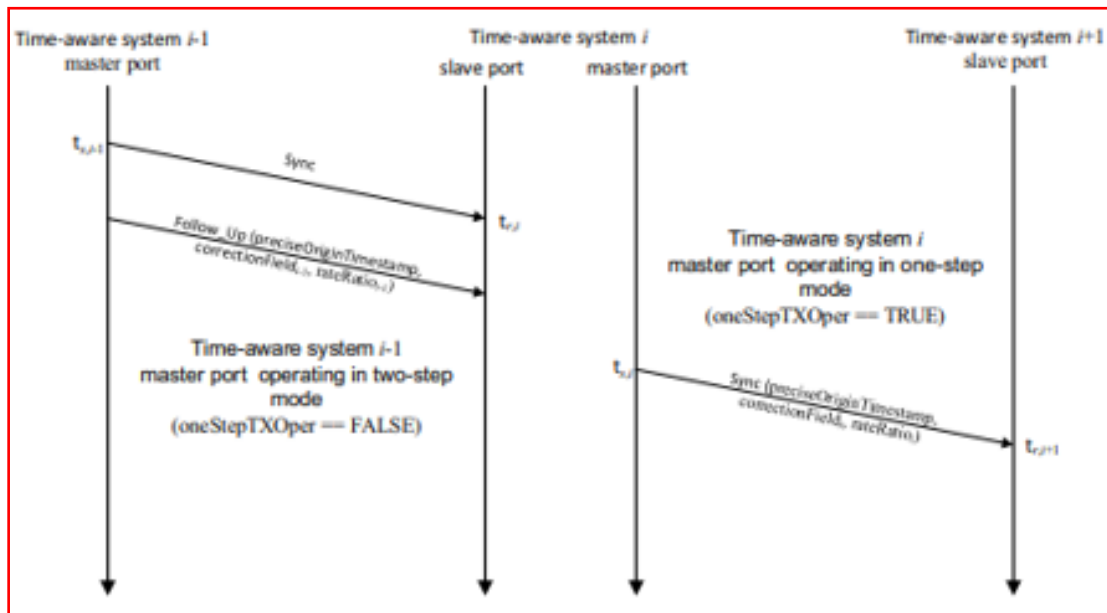

Figure 11-2—Transport of time-synchronization information

(Source: <https://1.ieee802.org/wp-content/uploads/2019/03/802-1AS-rev-d8-0.pdf>)

- c) In gPTP there are only two types of PTP Instances: PTP End Instances and PTP Relay Instances, while IEEE 1588 has ordinary clocks, boundary clocks, end-to-end transparent clocks, and P2P transparent clocks. A PTP End Instance corresponds to an IEEE 1588 ordinary clock, and a PTP Relay Instance is a type of IEEE 1588 boundary clock where its operation is very tightly defined, so much so that a PTP Relay Instance with Ethernet ports can be shown to be mathematically equivalent to a P2P transparent clock in terms of how synchronization is performed, as shown in

(Source: <https://1.ieee802.org/wp-content/uploads/2019/03/802-1AS-rev-d8-0.pdf>)

30. The methods practiced by Analog's use of the accused products include synchronizing the clocks of the remaining device adapters with said master timing device. For

example, the accused products are used by Analog to implement the IEEE 802.1Q standard. The boundary clocks of the slave ports in the time aware bridges (remaining device adapters) are synchronized with the grandmaster boundary clock (master timing device).

c) In gPTP there are only two types of PTP Instances: PTP End Instances and PTP Relay Instances, while IEEE 1588 has ordinary clocks, boundary clocks, end-to-end transparent clocks, and P2P transparent clocks. A PTP End Instance corresponds to an IEEE 1588 ordinary clock, and a PTP Relay Instance is a type of IEEE 1588 boundary clock where its operation is very tightly defined, so much so that a PTP Relay Instance with Ethernet ports can be shown to be mathematically equivalent to a P2P transparent clock in terms of how synchronization is performed, as shown in

(Source: <https://1.ieee802.org/wp-content/uploads/2019/03/802-1AS-rev-d8-0.pdf>)

3.16 PTP End Instance: A PTP Instance that is capable of acting as the source of synchronized time on the network, or destination of synchronized time using the IEEE 802.1AS protocol, or both.

3.17 PTP Instance: A PTP Relay Instance or a PTP End Instance. A PTP Instance implements those portions of this standard indicated as applicable to a PTP Relay Instance or a PTP End Instance. Each PTP Instance operates in exactly one domain.

3.18 PTP Link: Within a domain, a network segment between two PTP Ports using the peer-to-peer delay mechanism of this standard. The peer-to-peer delay mechanism is designed to measure the propagation time over such a link.

NOTE—A PTP Link between PTP Ports of PTP Instances is also a gPTP Communication Path (see 3.9).

3.19 PTP Relay Instance: A PTP Instance that is capable of communicating synchronized time received on one port to other ports, using the IEEE 802.1AS protocol.

NOTE—A PTP Relay Instance could, for example, be contained in a bridge, a router, or a multi-port end station.

(Source: <https://1.ieee802.org/wp-content/uploads/2019/03/802-1AS-rev-d8-0.pdf>)

11.1.3 Transport of time-synchronization information

The transport of time-synchronization information by a PTP Instance, using Sync and Follow_Up (or just Sync) messages, is illustrated in Figure 11-2. The mechanism is mathematically equivalent to the mechanism described in IEEE Std 1588-2019 for a peer-to-peer transparent clock that is synchronized (see 11.4.5.1, 11.5.1, and 11.5.2.2 of IEEE Std 1588-2019). However, as will be seen shortly, the processes of transporting synchronization by a peer-to-peer transparent clock that is synchronized and by a boundary clock are mathematically and functionally equivalent. The main functional difference between the two types of clocks is that the boundary clock participates in best master selection and invokes the BMCA, while the peer-to-peer transparent clock does not participate in best master selection and does not invoke the BMCA (and implementations of the two types of clocks can be different).

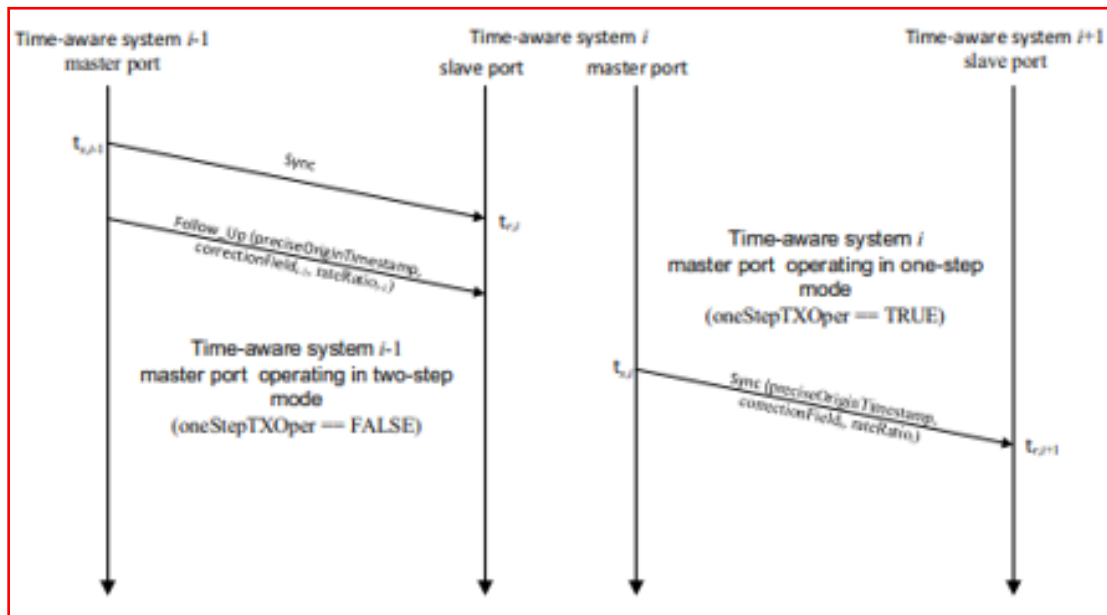

Figure 11-2—Transport of time-synchronization information

(Source: <https://1.ieee802.org/wp-content/uploads/2019/03/802-1AS-rev-d8-0.pdf>)

31. Far North Patents has been damaged as a result of the infringing conduct by Analog alleged above. Thus, Analog is liable to Far North Patents in an amount that adequately compensates it for such infringements, which, by law, cannot be less than a reasonable royalty, together with interest and costs as fixed by this Court under 35 U.S.C. § 284.

32. Far North Patents and/or its predecessors-in-interest have satisfied all statutory obligations required to collect pre-filing damages for the full period allowed by law for infringement of the ‘702 Patent.

COUNT III

DIRECT INFRINGEMENT OF U.S. PATENT NO. 6,215,797

33. On April 10, 2001, United States Patent No. 6,215,797 (“the ‘797 Patent”) was duly and legally issued by the United States Patent and Trademark Office for an invention entitled “Methods and Apparatus for Providing Quality of Service Guarantees in Computer Networks.”

34. Far North Patents is the owner of the ‘797 Patent, with all substantive rights in and to that patent, including the sole and exclusive right to prosecute this action and enforce the ‘797 Patent against infringers, and to collect damages for all relevant times.

35. Analog made, had made, used, imported, provided, supplied, distributed, sold, and/or offered for sale products and/or systems including, for example, its Analog Fido5000 REM switch family (5100/5200) and its Analog EVAL-RapID-TSNEK TSN Evaluation Kit families of products that include advanced quality of service capabilities (collectively, “accused products”).

ANALOG DEVICES
AHEAD OF WHAT'S POSSIBLE™

Search

MYANALOG | MY HISTORY | **PRODUCTS** | APPLICATIONS | DESIGN CENTER | EDUCATION | SUPPORT

Products > Industrial Ethernet > Industrial Ethernet Embedded Switches

Print myAnalog

Industrial Ethernet Embedded Switches

REM Switch Family Supports All Major Industrial Ethernet Protocols and Connects to Any Processor to Build Any Field Device or Controller Application.

The fido5000 REM switch family includes two 2-port, Industrial Ethernet embedded switches that interface to any processor, including any ARM® CPU and ADI's fido1100 communication controller. ADI's PriorityChannel™ technology has been integrated into their hardware architecture and designed into the REM switch software drivers. The protocols supported by these switches are PROFINET Class C (IRT) and Class B (RT), EtherNet/IP® with and without DLR, Modbus® TCP, EtherCAT®, and POWERLINK®. The REM switches come with a software driver for each protocol. The software drivers provide an API for integration with any field device or controller protocol stack. ADI is certifying REM and its software drivers at each protocol's sponsoring industry organization using ADI's Rapid platform.



fido5100 data sheet, specs and more



fido5200 data sheet, specs, and more

(Source : <https://www.analog.com/en/products/industrial-ethernet/industrial-ethernet-embedded-switches.html>)

Embedded Switches

	Port Count	Protocol Support	TSN Features	Package	Power
fido5100	2	PROFINET, Ethernet/IP®, POWERLINK®, Modbus® TCP	802.1AS (Time synchronization); 802.1Qbv (Scheduled traffic); 802.1CB (Redundancy); 802.1Qcc (Configuration)	144-ball, 10 mm × 10 mm CSP_BGA	160 mW
fido5200	2	EtherCAT®, PROFINET, Ethernet/IP, POWERLINK, Modbus TCP	802.1AS (Time synchronization); 802.1Qbv (Scheduled traffic); 802.1CB (Redundancy); 802.1Qcc (Configuration)	144-ball, 10 mm × 10 mm CSP_BGA	160 mW

(Source : screenshot of PDF downloaded from <https://www.analog.com/media/en/news-marketing-collateral/solutions-bulletins-brochures/scalable-ethernet-timed-to-perfection.pdf>)

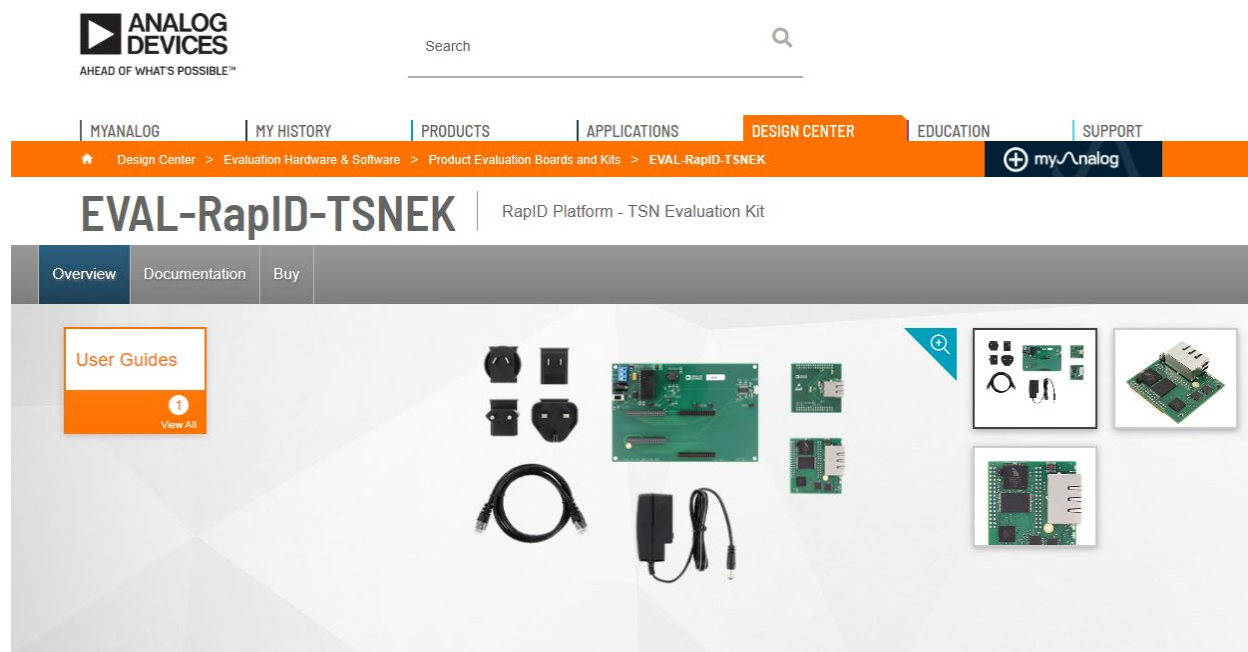

(Source : <https://www.analog.com/en/design-center/evaluation-hardware-and-software/evaluation-boards-kits/eval-rapid-tsnek.html#eb-overview>)

Product Details

The TSN Evaluation Kit is configured to provide TSN Gateway functionality in order to quickly assess TSN features and capabilities and better understand how TSN works. From there, it is possible to utilize fido5000 Real-time Ethernet Multi-protocol (REM) Switch chip to provide a TSN solution in your product's application. The figure below shows how the TSN Kit architecture relates to a "partitioned" communication architecture and to an "integrated" communications architecture.

Using the TSN gateway functionality allows a non-TSN device to participate in a TSN network without implementing TSN-specific features natively. The TSN gateway has built-in features from the following IEEE specifications:

- 802.1AS, AS-REV – Time Synchronization
- 802.1Qbv – Scheduled Traffic
- 802.1Qci – Ingress Policing
- 802.1CB – Seamless Redundancy
- 802.1Qcc – Stream Reservation Protocol
- 802.1Qbu / 802.3br – Preemption

The TSN gateway comes pre-installed with software that supports 802.1AS, 802.1Qbv, 802.1Qcc, and stream translation. Software updates will be provided to add TSN features and correct any interoperability issues. 802.1Qcc is currently implemented using a webserver, but will ultimately be implemented so the gateway can be configured by a Central Network Controller (CNC).

(Source : <https://www.analog.com/en/design-center/evaluation-hardware-and-software/evaluation-boards-kits/eval-rapid-tsnek.html#eb-overview>)

36. By doing so, Analog has directly infringed (literally and/or under the doctrine of equivalents) at least Claim 30 of the '797 Patent.

37. Analog has infringed the '797 Patent by using the accused products and thereby practicing a method for regulating traffic in a network including devices for generating packets of data, a network medium for carrying the packets, and a plurality of device adapters connected between the devices and the network medium. For example, the accused products are used by Analog to implement the IEEE 802.1Q standard. IEEE standard 802.1Q (Qbv) implements a method for scheduling traffic in time aware Local Area Network. The time aware network includes multiple end points that transmit data packets and bridges that includes ports (device adapters). The interconnects (network medium) carry the transmitted data packets. The endpoints and bridges are connected via interconnects.

1.1 Project Number: P802.1Qbv

1.2 Type of Document: Standard

1.3 Life Cycle: Full Use

2.1 Title: Standard for Local and metropolitan area networks--Media Access Control (MAC) Bridges and Virtual Bridged Local Area Networks Amendment: Enhancements for Scheduled Traffic

5.2.b. Scope of the project: This amendment specifies time-aware queue-draining procedures, managed objects and extensions to existing protocols that enable bridges and end stations to schedule the transmission of frames based on a synchronized time. Virtual Local Area Network (VLAN) tag encoded priority values are allocated allowing simultaneous support of scheduled traffic, credit-based shaper traffic and other bridged traffic over Local Area Networks (LANs).

(Source: <http://www.ieee802.org/1/files/public/docs2014/bv-p802-1Qbv-par-modification-1114.pdf>)

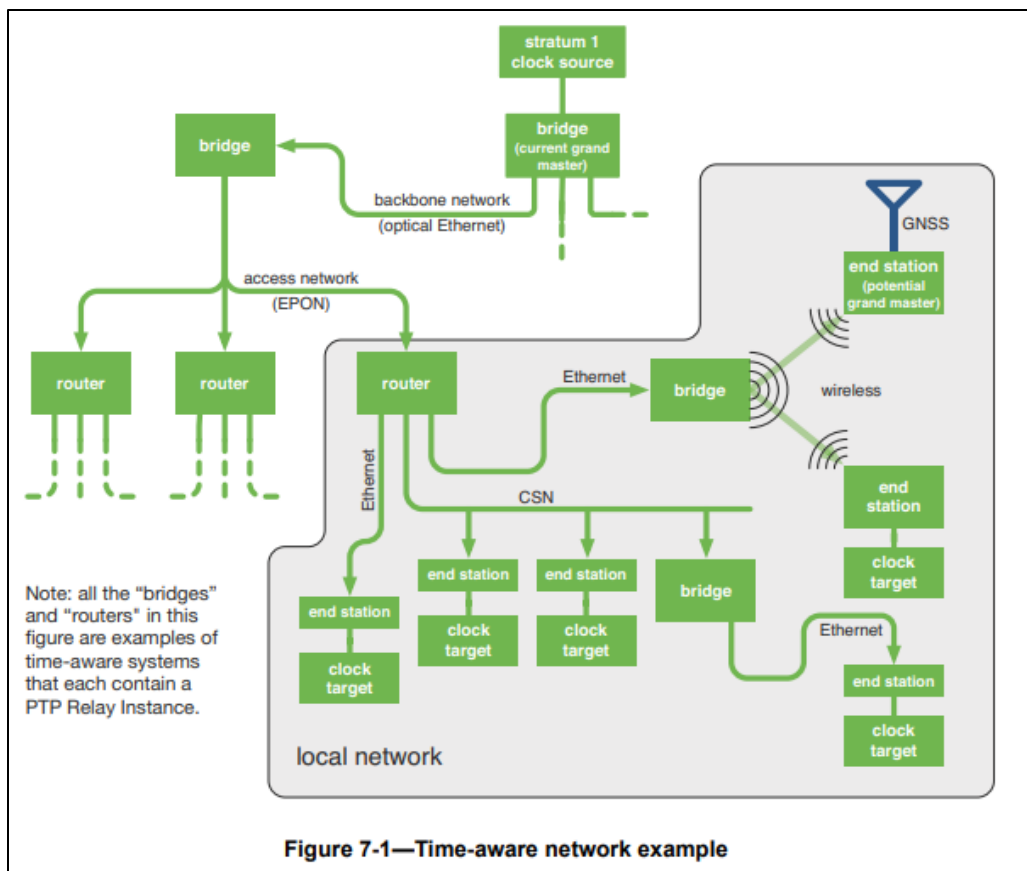

(Source: <https://1.ieee802.org/wp-content/uploads/2019/03/802-1AS-rev-d8-0.pdf>)

7.2 Architecture of a time-aware network

7.2.1 General

A time-aware network consists of a number of interconnected time-aware systems that support the gPTP defined within this standard. These time-aware systems can be any networking device, including, for example, bridges, routers, and end stations. A set of time-aware systems that are interconnected by gPTP-capable network elements is called a gPTP network. Each instance of gPTP that the time-aware systems support is in one *gPTP domain*, and the instances of gPTP are said to be part of that gPTP domain. A time-aware system can support, and therefore be part of, more than one gPTP domain. The entity of a single time-aware system that executes gPTP in one gPTP domain is called a PTP Instance. A time-aware system can contain multiple PTP Instances, which are each associated with a different gPTP domain. There are two

(Source: <https://1.ieee802.org/wp-content/uploads/2019/03/802-1AS-rev-d8-0.pdf>)

Traffic scheduling

This annex provides some background to the mechanisms provided in this standard for traffic scheduling, with the intent of providing some insight into the motivation for the provision of mechanisms for traffic scheduling and some of the ways that the mechanisms might be used.

Q.1 Motivation

Some applications have a need for frame delivery that is highly predictable in terms of the time at which frame transmission will occur, and the overall latency and jitter that will be experienced as the frame is propagated to its destination. Examples include industrial and automotive control applications, where data transmitted over the network is used to feed the parameters of control loops that are critical to the operation of the plant or machinery involved, and where frames carrying control data are transmitted on a repeating time schedule; late delivery of such frames can result in instability, inaccuracy, or failure of the operation of the control loops concerned. In some implementations, this need has been met by the provision of dedicated, highly engineered networks that are used solely for the transmission of time-critical control traffic; however, as the bandwidth occupied by such traffic is often low, and the cost of providing a dedicated control network can be high, it can be desirable to mix time-critical traffic with other classes of traffic in the same network, as long as such mixing can be achieved while still meeting the timing requirements of the time-critical traffic.

(Source: IEEE Standard for Local and metropolitan area networks— Bridges and Bridged Networks Amendment 25: Enhancements for Scheduled Traffic (IEEE 802.1Qbv-2015))

b) gPTP specifies a media-independent sublayer that simplifies the integration within a single timing domain of multiple different networking technologies with radically different media access protocols. gPTP specifies a media-dependent sublayer for each medium. The information exchanged between PTP Instances has been generalized to support different packet formats and management schemes appropriate to the particular networking technology. IEEE Std 1588-2019, on the other

(Source: <https://1.ieee802.org/wp-content/uploads/2019/03/802-1AS-rev-d8-0.pdf>)

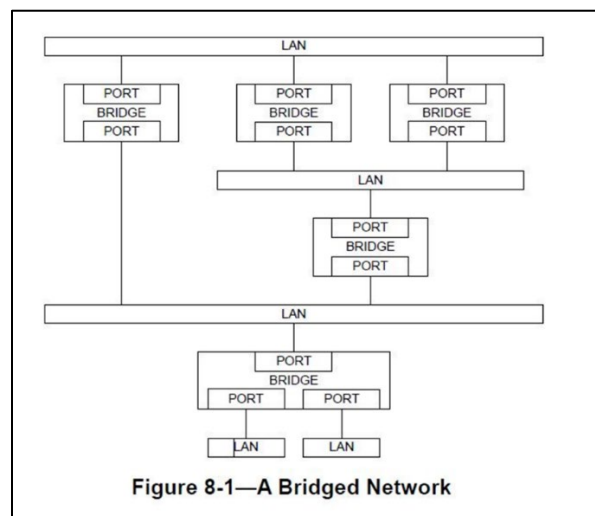

(Source: IEEE Standard for Local and Metropolitan Area Networks—Bridges and Bridged Networks- IEEE Std 802.1Q™-2018)

38. The methods practiced by Analog's use of the accused products include defining a common time reference for the device adapters, said common time reference including a frame of time having a plurality of time phases, each device adapter being uniquely assigned to one of said plurality of time phases, said plurality of time phases including a free-access phase. For example, the accused products are used by Analog to implement the IEEE 802.1Q standard. The time aware bridged LAN uses 802.1AS base time to maintain synchronized time (common time reference) for all the ports in the bridges (device adapters). The bridges containing ports are scheduled for transmission of traffic based on the synchronized time. Each port associated with a specific set of transmission queues includes a plurality of transmission gates. A transmission gate can be in a closed state or open state. The functionality of assigned time phases is achieved using open gates transmitting data packets during transmission time. The functionality of free access phase is achieved when the gates are opened for transmission during any time. IEEE Std. 802.1AS™-2011 is normative and essential to implement an IEEE Std. 802.1Q Compliant System.

1.1 Project Number: P802.1Qbv

1.2 Type of Document: Standard

1.3 Life Cycle: Full Use

2.1 Title: Standard for Local and metropolitan area networks--Media Access Control (MAC) Bridges and Virtual Bridged Local Area Networks Amendment: Enhancements for Scheduled Traffic

5.2.b. Scope of the project: This amendment specifies time-aware queue-draining procedures, managed objects and extensions to existing protocols that enable bridges and end stations to schedule the transmission of frames based on a synchronized time. Virtual Local Area Network (VLAN) tag encoded priority values are allocated allowing simultaneous support of scheduled traffic, credit-based shaper traffic and other bridged traffic over Local Area Networks (LANs).

(Source: <http://www.ieee802.org/1/files/public/docs2014/bv-p802-1Qbv-par-modification-1114.pdf>)

IEEE Std 802.1Q-2018
IEEE Standard for Local and Metropolitan Area Networks—Bridges and Bridged Networks

2. Normative references

The following referenced documents are indispensable for the application of this document (i.e., they must be understood and used, so each referenced document is cited in the text and its relationship to this document is explained). For dated references, only the edition cited applies. For undated references, the latest edition of the referenced document (including any amendments or corrigenda) applies.

ANSI X3.159, American National Standards for Information Systems—Programming Language—C.⁵

IEEE Std 802[®], IEEE Standard for Local and metropolitan area networks: Overview and Architecture.^{6,7}

IEEE Std 802.1AB™, IEEE Standard for Local and metropolitan area networks—Station and Media Access Control Connectivity Discovery.

IEEE Std 802.1AC™, IEEE Standard for Local and metropolitan area networks—Media Access Control (MAC) Service Definition.

IEEE Std 802.1AE™, IEEE Standard for Local and metropolitan area networks—Media Access Control (MAC) Security.

IEEE Std 802.1AS™, IEEE Standard for Local and metropolitan area networks—Timing and Synchronization for Time-Sensitive Applications in Bridged Local Area Networks.

(Source: IEEE Standard for Local and Metropolitan Area Networks—Bridges and Bridged Networks- IEEE Std 802.1Q™-2018)

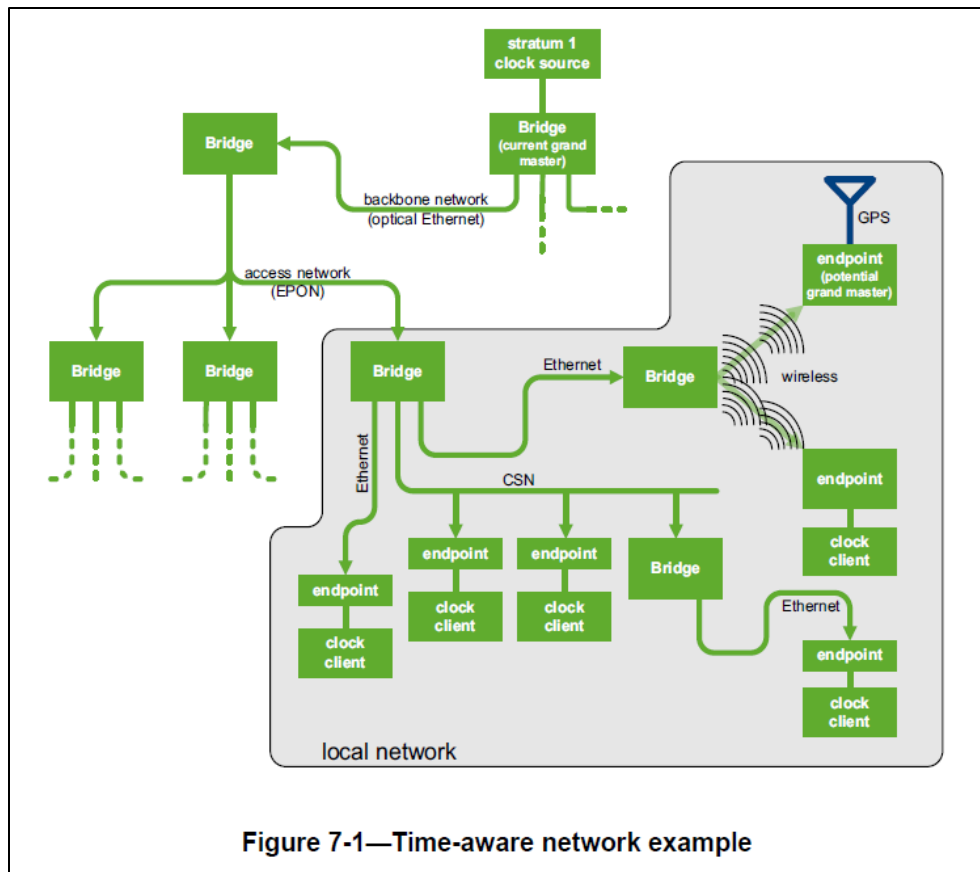

(Source: IEEE Standard for Local and metropolitan area networks - Timing and Synchronization for Time - Sensitive Applications in Bridged Local Area Networks - IEEE Std 802.1AS™-2011)

3.16 PTP End Instance: A PTP Instance that is capable of acting as the source of synchronized time on the network, or destination of synchronized time using the IEEE 802.1AS protocol, or both.

3.17 PTP Instance: A PTP Relay Instance or a PTP End Instance. A PTP Instance implements those portions of this standard indicated as applicable to a PTP Relay Instance or a PTP End Instance. Each PTP Instance operates in exactly one domain.

3.18 PTP Link: Within a domain, a network segment between two PTP Ports using the peer-to-peer delay mechanism of this standard. The peer-to-peer delay mechanism is designed to measure the propagation time over such a link.

NOTE—A PTP Link between PTP Ports of PTP Instances is also a gPTP Communication Path (see 3.9).

3.19 PTP Relay Instance: A PTP Instance that is capable of communicating synchronized time received on one port to other ports, using the IEEE 802.1AS protocol.

NOTE—A PTP Relay Instance could, for example, be contained in a bridge, a router, or a multi-port end station.

(Source: <https://1.ieee802.org/wp-content/uploads/2019/03/802-1AS-rev-d8-0.pdf>)

8.6.8.4 Enhancements for scheduled traffic

A Bridge or an end station may support enhancements that allow transmission from each queue to be scheduled relative to a known timescale. In order to achieve this, a transmission gate is associated with each queue; the state of the transmission gate determines whether or not queued frames can be selected for transmission (see Figure 8-12). For a given queue, the transmission gate can be in one of two states:

- a) Open: Queued frames are selected for transmission, in accordance with the definition of the transmission selection algorithm associated with the queue.
- b) Closed: Queued frames are not selected for transmission.

(Source: IEEE Standard for Local and metropolitan area networks— Bridges and Bridged Networks Amendment 25: Enhancements for Scheduled Traffic (IEEE 802.1Qbv-2015))

8.6.8 Transmission selection

For each Port, frames are selected for transmission on the basis of the traffic classes that the Port supports and the operation of the transmission selection algorithms supported by the corresponding queues on that Port. For a given Port and traffic class, frames are selected from the corresponding queue for transmission if and only if

- a) The operation of the transmission selection algorithm supported by that queue determines that there is a frame available for transmission; and
- b) For each queue corresponding to a numerically higher value of traffic class supported by the Port, the operation of the transmission selection algorithm supported by that queue determines that there is no frame available for transmission.

(Source: IEEE Standard for Local and Metropolitan Area Networks—Bridges and Bridged Networks- IEEE Std 802.1Q™-2018)

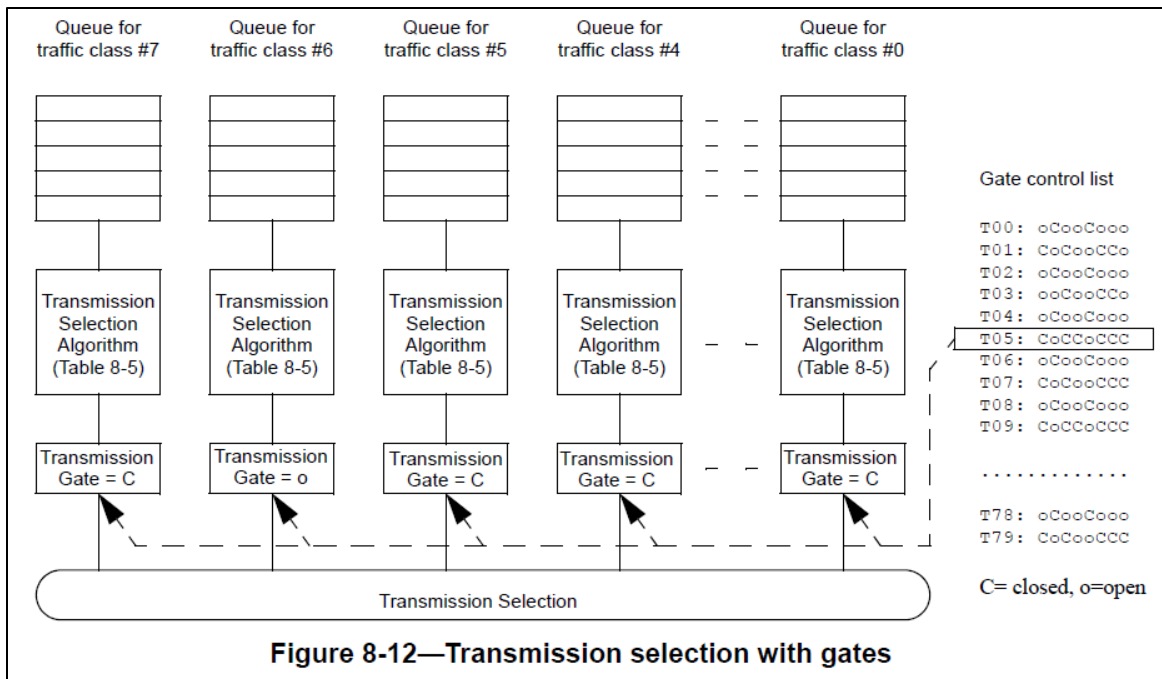

(Source: IEEE Standard for Local and metropolitan area networks— Bridges and Bridged Networks Amendment 25: Enhancements for Scheduled Traffic (IEEE 802.1Qbv-2015))

A gate control list associated with each Port contains an ordered list of gate operations. Each gate operation changes the transmission gate state for the gate associated with each of the Port's traffic class queues. In an implementation that does not support enhancements for scheduled traffic, all gates are assumed to be permanently in the open state. Table 8-6 identifies the gate operation types, their parameters, and the actions that result from their execution. The state machines that control the execution of the gate control list, along with their variables and procedures, are specified in 8.6.9.

(Source: IEEE Standard for Local and metropolitan area networks— Bridges and Bridged Networks Amendment 25: Enhancements for Scheduled Traffic (IEEE 802.1Qbv-2015))

39. The methods practiced by Analog's use of the accused products include allowing a device adapter to transmit packets during said time phase uniquely assigned thereto and during said free-access phase. For example, the accused products are used by Analog to implement the IEEE 802.1Q standard. The open gates assigned to the transmission queue of a port (device adapter) transmit the data packets during the transmission time. The transmission selection algorithm determines the transmission time. If the gates are in permanent open state, the data packets are transmitted from the gates during any time. The functionality of assigned time phases

is achieved using open gates transmitting data packets during transmission time. The functionality of free access phase is achieved when the gates are permanently opened for transmission during any time.

8.6.8.4 Enhancements for scheduled traffic

A Bridge or an end station may support enhancements that allow transmission from each queue to be scheduled relative to a known timescale. In order to achieve this, a transmission gate is associated with each queue; the state of the transmission gate determines whether or not queued frames can be selected for transmission (see Figure 8-12). For a given queue, the transmission gate can be in one of two states:

- a) Open: Queued frames are selected for transmission, in accordance with the definition of the transmission selection algorithm associated with the queue.
- b) Closed: Queued frames are not selected for transmission.

(Source: IEEE Standard for Local and metropolitan area networks— Bridges and Bridged Networks Amendment 25: Enhancements for Scheduled Traffic (IEEE 802.1Qbv-2015))

3.4 transmission gate: A gate that connects or disconnects the transmission selection function of the forwarding process from the queue, allowing or preventing it from selecting frames from that queue. The gate has two states, Open and Closed.

(Source: IEEE Standard for Local and metropolitan area networks— Bridges and Bridged Networks Amendment 25: Enhancements for Scheduled Traffic (IEEE 802.1Qbv-2015))

11.1.3 Transport of time-synchronization information

The transport of time-synchronization information by a PTP Instance, using Sync and Follow_Up (or just Sync) messages, is illustrated in Figure 11-2. The mechanism is mathematically equivalent to the mechanism described in IEEE Std 1588-2019 for a peer-to-peer transparent clock that is synchronized (see 11.4.5.1, 11.5.1, and 11.5.2.2 of IEEE Std 1588-2019). However, as will be seen shortly, the processes of transporting synchronization by a peer-to-peer transparent clock that is synchronized and by a boundary clock are mathematically and functionally equivalent. The main functional difference between the two types of clocks is that the boundary clock participates in best master selection and invokes the BMCA, while the peer-to-peer transparent clock does not participate in best master selection and does not invoke the BMCA (and implementations of the two types of clocks can be different).

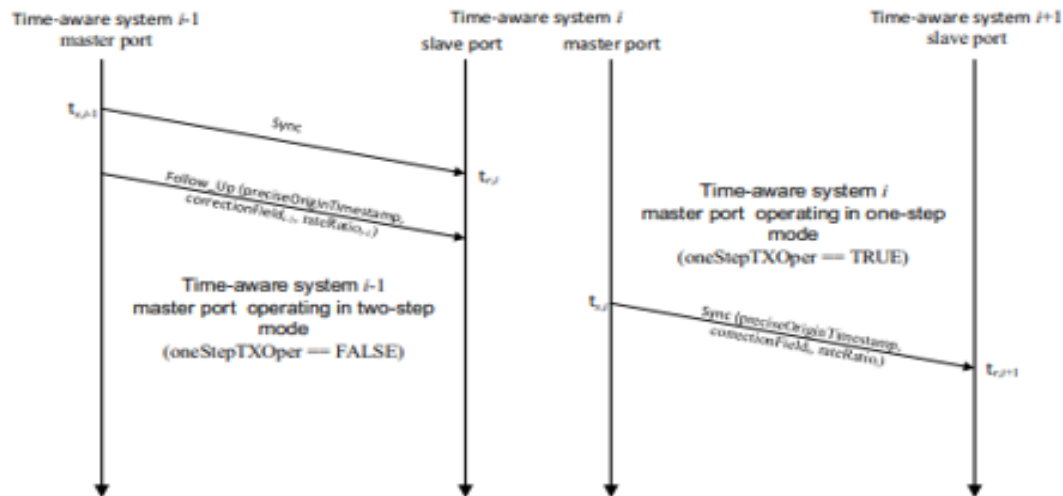

Figure 11-2—Transport of time-synchronization information

(Source: IEEE Standard for Local and metropolitan area networks— Bridges and Bridged Networks Amendment 25: Enhancements for Scheduled Traffic (IEEE 802.1Qbv-2015))

A gate control list associated with each Port contains an ordered list of gate operations. Each gate operation changes the transmission gate state for the gate associated with each of the Port's traffic class queues. In an implementation that does not support enhancements for scheduled traffic, all gates are assumed to be permanently in the open state. Table 8-6 identifies the gate operation types, their parameters, and the actions that result from their execution. The state machines that control the execution of the gate control list, along with their variables and procedures, are specified in 8.6.9.

(Source: IEEE Standard for Local and metropolitan area networks— Bridges and Bridged Networks Amendment 25: Enhancements for Scheduled Traffic (IEEE 802.1Qbv-2015))

40. The methods practiced by Analog's use of the accused products include cyclically repeating said frame. For example, the accused products are used by Analog to implement the

IEEE 802.1Q standard. IEEE Std. 802.1Q-2018 supports cyclic queuing and forwarding structures to create synchronized frames and gates that are repeated periodically (Annex T).

Cyclic queuing and forwarding⁵³

T.1 Overview of CQF

Cyclic queuing and forwarding (CQF) is a method of traffic shaping that can deliver deterministic, and easily calculated, latency for time-sensitive traffic streams. As the name implies, the principle underlying CQF is that stream traffic is transmitted and queued for transmission along a network path in a cyclic manner. Time is divided into numbered time intervals $i, i+1, i+2, \dots, i+N$, each of duration d . Frames transmitted by a Bridge, *Alice*, during time interval i are received by a downstream Bridge, *Bob*, during time interval i and are transmitted onwards by *Bob* towards Bridge *Charlie* during time interval $i+1$, and so on. A starting assumption is that, for a given traffic class, all Bridges and all end stations connected to a given bridge have a common understanding (to a known accuracy) of the start time of cycle i , and the cycle duration, d .

Frames transmitted by *Alice* during interval i are transmitted by *Bob* in interval $i+1$; the maximum possible delay experienced by a given frame is from the beginning of i to the end of $i+1$, or twice d . Similarly, the minimum possible delay experienced is from the end of i to the beginning of $i+1$, which is zero. More generally, the maximum delay experienced by a given frame is

$$(h+1) \times d$$

and the minimum delay experienced by a given frame is

$$(h-1) \times d$$

where h is the number of hops.

(Source: IEEE Standard for Local and Metropolitan Area Networks—Bridges and Bridged Networks- IEEE Std 802.1Q™-2018)

Traffic scheduling

This annex provides some background to the mechanisms provided in this standard for traffic scheduling, with the intent of providing some insight into the motivation for the provision of mechanisms for traffic scheduling and some of the ways that the mechanisms might be used.

Q.1 Motivation

Some applications have a need for frame delivery that is highly predictable in terms of the time at which frame transmission will occur, and the overall latency and jitter that will be experienced as the frame is propagated to its destination. Examples include industrial and automotive control applications, where data transmitted over the network is used to feed the parameters of control loops that are critical to the operation of the plant or machinery involved, and where frames carrying control data are transmitted on a repeating time schedule; late delivery of such frames can result in instability, inaccuracy, or failure of the operation of the control loops concerned. In some implementations, this need has been met by the provision of dedicated, highly engineered networks that are used solely for the transmission of time-critical control traffic; however, as the bandwidth occupied by such traffic is often low, and the cost of providing a dedicated control network can be high, it can be desirable to mix time-critical traffic with other classes of traffic in the same network, as long as such mixing can be achieved while still meeting the timing requirements of the time-critical traffic.

(Source: IEEE Standard for Local and metropolitan area networks— Bridges and Bridged

Networks Amendment 25: Enhancements for Scheduled Traffic (IEEE 802.1Qbv-2015))

41. Far North Patents has been damaged as a result of the infringing conduct by Analog alleged above. Thus, Analog is liable to Far North Patents in an amount that adequately compensates it for such infringements, which, by law, cannot be less than a reasonable royalty, together with interest and costs as fixed by this Court under 35 U.S.C. § 284.

42. Far North Patents and/or its predecessors-in-interest have satisfied all statutory obligations required to collect pre-filing damages for the full period allowed by law for infringement of the '797 Patent.

COUNT IV

DIRECT INFRINGEMENT OF U.S. PATENT NO. 8,891,504

43. On November 18, 2014, United States Patent No. 8,891,504 (“the ‘504 Patent”) was duly and legally issued by the United States Patent and Trademark Office for an invention entitled “Methods and Apparatus for Providing Quality of Service Guarantees in Computer Networks.”

44. Far North Patents is the owner of the ‘504 Patent, with all substantive rights in and to that patent, including the sole and exclusive right to prosecute this action and enforce the ‘504 Patent against infringers, and to collect damages for all relevant times.

45. Analog made, had made, used, imported, provided, supplied, distributed, sold, and/or offered for sale products and/or systems including, for example, its Analog Fido5000 REM switch family (5100/5200) and its Analog EVAL-RapID-TSNEK TSN Evaluation Kit families of products that include advanced quality of service capabilities (collectively, “accused products”).

Industrial Ethernet Embedded Switches

REM Switch Family Supports All Major Industrial Ethernet Protocols and Connects to Any Processor to Build Any Field Device or Controller Application.

The fido5000 REM switch family includes two 2-port, Industrial Ethernet embedded switches that interface to any processor, including any ARM® CPU and ADI's fido1100 communication controller. ADI's PriorityChannel™ technology has been integrated into their hardware architecture and designed into the REM switch software drivers. The protocols supported by these switches are PROFINET Class C (IRT) and Class B (RT), EtherNet/IP® with and without DLR, Modbus® TCP, EtherCAT®, and POWERLINK®. The REM switches come with a software driver for each protocol. The software drivers provide an API for integration with any field device or controller protocol stack. ADI is certifying REM and its software drivers at each protocol's sponsoring industry organization using ADI's Rapid platform.



fido5100 data sheet, specs and more



fido5200 data sheet, specs, and more

(Source : <https://www.analog.com/en/products/industrial-ethernet/industrial-ethernet-embedded-switches.html>)

Embedded Switches

	Port Count	Protocol Support	TSN Features	Package	Power
fido5100	2	PROFINET, Ethernet/IP®, POWERLINK®, Modbus® TCP	802.1AS (Time synchronization); 802.1Qbv (Scheduled traffic); 802.1CB (Redundancy); 802.1Qcc (Configuration)	144-ball, 10 mm × 10 mm CSP_BGA	160 mW
fido5200	2	EtherCAT®, PROFINET, Ethernet/IP, POWERLINK, Modbus TCP	802.1AS (Time synchronization); 802.1Qbv (Scheduled traffic); 802.1CB (Redundancy); 802.1Qcc (Configuration)	144-ball, 10 mm × 10 mm CSP_BGA	160 mW

(Source : screenshot of PDF downloaded from <https://www.analog.com/media/en/news-marketing-collateral/solutions-bulletins-brochures/scalable-ethernet-timed-to-perfection.pdf>)

(Source : <https://www.analog.com/en/design-center/evaluation-hardware-and-software/evaluation-boards-kits/eval-rapid-tsnek.html#eb-overview>)

Product Details

The TSN Evaluation Kit is configured to provide TSN Gateway functionality in order to quickly assess TSN features and capabilities and better understand how TSN works. From there, it is possible to utilize fido5000 Real-time Ethernet Multi-protocol (REM) Switch chip to provide a TSN solution in your product's application. The figure below shows how the TSN Kit architecture relates to a "partitioned" communication architecture and to an "integrated" communications architecture.

Using the TSN gateway functionality allows a non-TSN device to participate in a TSN network without implementing TSN-specific features natively. The TSN gateway has built-in features from the following IEEE specifications:

- 802.1AS, AS-REV – Time Synchronization
- 802.1Qbv – Scheduled Traffic
- 802.1Qci – Ingress Policing
- 802.1CB – Seamless Redundancy
- 802.1Qcc – Stream Reservation Protocol
- 802.1Qbu / 802.3br – Preemption

The TSN gateway comes pre-installed with software that supports 802.1AS, 802.1Qbv, 802.1Qcc, and stream translation. Software updates will be provided to add TSN features and correct any interoperability issues. 802.1Qcc is currently implemented using a webserver, but will ultimately be implemented so the gateway can be configured by a Central Network Controller (CNC).

(Source : <https://www.analog.com/en/design-center/evaluation-hardware-and-software/evaluation-boards-kits/eval-rapid-tsnek.html#eb-overview>)

46. By doing so, Analog has directly infringed (literally and/or under the doctrine of equivalents) at least Claims 1 and 6 of the ‘504 Patent.

47. Analog has infringed the ‘504 Patent by making, having made, using, importing, providing, supplying, distributing, selling or offering for sale products including a device adapter comprising a transmission unit configured to transmit data from a real time device via a network according to a time frame, wherein the time frame is substantially synchronized in the device adapter and at least one other device adapter, the time frame repeating periodically and including a plurality of assigned time phases and a free access phase. For example, the accused products are configured to be used to implement the IEEE 802.1Q standard. IEEE standard 802.1Q implements a method in which a time aware bridged LAN transmits data from one end point i.e., Precision Time Protocol (“PTP”) instance to another. The endpoints transmit data that is a mix of time-critical traffic and other traffic, (i.e., real time data and non-real time data) via PTP instances such as bridges (device adapters). The end point can be either a real time device or a non-real time device. The bridged network uses 802.1AS base time to synchronize all the clocks of ports associated with bridges (device adapters). Using the Best Master Clock Algorithm, the synchronization time signal is transmitted from a grandmaster to other ports. IEEE Std. 802.1AS™-2011 is normative and essential to implement an IEEE Std. 802.1Q Compliant System. IEEE Std. 802.1Q-2018 defines parameters, such as AdminBaseTime and OpenBaseTime, which are used to synchronize the clocks across the network. The bridges containing ports schedule the transmission of traffic based on the synchronized time. Each port associated with a specific set of transmission queues includes a plurality of transmission gates. A

transmission gate can be in a closed state or open state. The functionality of assigned time phases is achieved using open gates transmitting data packets during transmission time. The functionality of a free access phase is achieved when the gates are opened for transmission during any time. IEEE Std. 802.1Q-2018 supports cyclic queuing and forwarding structures to create synchronized frames and gates which repeat periodically (Annex T).

1.1 Project Number: P802.1Qbv

1.2 Type of Document: Standard

1.3 Life Cycle: Full Use

2.1 Title: Standard for Local and metropolitan area networks--Media Access Control (MAC) Bridges and Virtual Bridged Local Area Networks Amendment: Enhancements for Scheduled Traffic

5.2.b. Scope of the project: This amendment specifies time-aware queue-draining procedures, managed objects and extensions to existing protocols that enable bridges and end stations to schedule the transmission of frames based on a synchronized time. Virtual Local Area Network (VLAN) tag encoded priority values are allocated allowing simultaneous support of scheduled traffic, credit-based shaper traffic and other bridged traffic over Local Area Networks (LANs).

(Source: <http://www.ieee802.org/1/files/public/docs2014/bv-p802-1Qbv-par-modification-1114.pdf>)

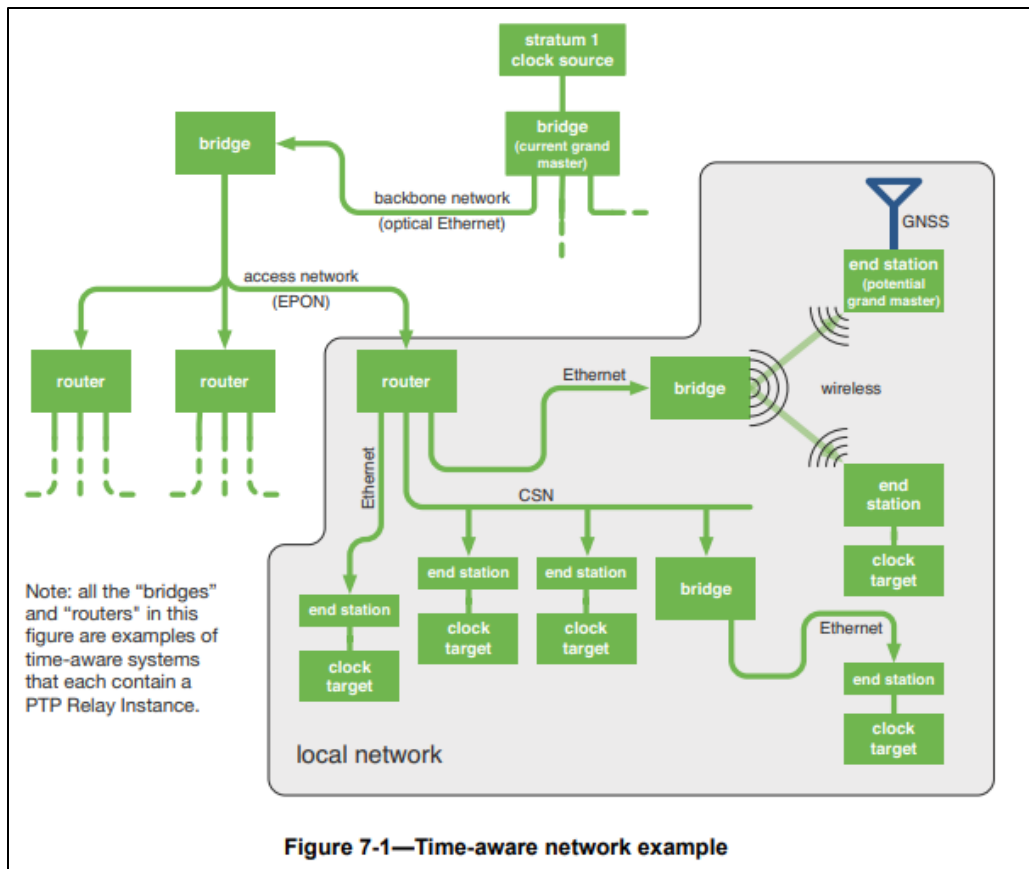

(Source: <https://1.ieee802.org/wp-content/uploads/2019/03/802-1AS-rev-d8-0.pdf>)

7.2 Architecture of a time-aware network

7.2.1 General

A time-aware network consists of a number of interconnected time-aware systems that support the gPTP defined within this standard. These time-aware systems can be any networking device, including, for example, bridges, routers, and end stations. A set of time-aware systems that are interconnected by gPTP-capable network elements is called a gPTP network. Each instance of gPTP that the time-aware systems support is in one gPTP domain, and the instances of gPTP are said to be part of that gPTP domain. A time-aware system can support, and therefore be part of, more than one gPTP domain. The entity of a single time-aware system that executes gPTP in one gPTP domain is called a PTP Instance. A time-aware system can contain multiple PTP Instances, which are each associated with a different gPTP domain. There are two

(Source: <https://1.ieee802.org/wp-content/uploads/2019/03/802-1AS-rev-d8-0.pdf>)

3.16 PTP End Instance: A PTP Instance that is capable of acting as the source of synchronized time on the network, or destination of synchronized time using the IEEE 802.1AS protocol, or both.

3.17 PTP Instance: A PTP Relay Instance or a PTP End Instance. A PTP Instance implements those portions of this standard indicated as applicable to a PTP Relay Instance or a PTP End Instance. Each PTP Instance operates in exactly one domain.

3.18 PTP Link: Within a domain, a network segment between two PTP Ports using the peer-to-peer delay mechanism of this standard. The peer-to-peer delay mechanism is designed to measure the propagation time over such a link.

NOTE—A PTP Link between PTP Ports of PTP Instances is also a gPTP Communication Path (see 3.9).

3.19 PTP Relay Instance: A PTP Instance that is capable of communicating synchronized time received on one port to other ports, using the IEEE 802.1AS protocol.

NOTE—A PTP Relay Instance could, for example, be contained in a bridge, a router, or a multi-port end station.

(Source: <https://1.ieee802.org/wp-content/uploads/2019/03/802-1AS-rev-d8-0.pdf>)

Traffic scheduling

This annex provides some background to the mechanisms provided in this standard for traffic scheduling, with the intent of providing some insight into the motivation for the provision of mechanisms for traffic scheduling and some of the ways that the mechanisms might be used.

Q.1 Motivation

Some applications have a need for frame delivery that is highly predictable in terms of the time at which frame transmission will occur, and the overall latency and jitter that will be experienced as the frame is propagated to its destination. Examples include industrial and automotive control applications, where data transmitted over the network is used to feed the parameters of control loops that are critical to the operation of the plant or machinery involved, and where frames carrying control data are transmitted on a repeating time schedule; late delivery of such frames can result in instability, inaccuracy, or failure of the operation of the control loops concerned. In some implementations, this need has been met by the provision of dedicated, highly engineered networks that are used solely for the transmission of time-critical control traffic; however, as the bandwidth occupied by such traffic is often low, and the cost of providing a dedicated control network can be high, it can be desirable to mix time-critical traffic with other classes of traffic in the same network, as long as such mixing can be achieved while still meeting the timing requirements of the time-critical traffic.

(Source: IEEE Standard for Local and metropolitan area networks— Bridges and Bridged Networks Amendment 25: Enhancements for Scheduled Traffic (IEEE 802.1Qbv-2015))

- b) gPTP specifies a media-independent sublayer that simplifies the integration within a single timing domain of multiple different networking technologies with radically different media access protocols. gPTP specifies a media-dependent sublayer for each medium. The information exchanged between PTP Instances has been generalized to support different packet formats and management schemes appropriate to the particular networking technology. IEEE Std 1588-2019, on the other

(Source: <https://1.ieee802.org/wp-content/uploads/2019/03/802-1AS-rev-d8-0.pdf>)

7.2.2 Time-aware network consisting of a single gPTP domain

Figure 7-1 illustrates an example time-aware network consisting of a single gPTP domain, using all the above network technologies (i.e., (c) - (f) of 7.2.1), where end stations on several local networks are connected to a grandmaster on a backbone network via an EPON access network.

Any PTP Instance with clock sourcing capabilities can be a potential grandmaster, so there is a selection method (the best master clock algorithm, or BMCA) that ensures that all of the PTP Instances in a gPTP domain use the same grandmaster.¹² The BMCA is largely identical to that used in IEEE Std 1588-2019,

(Source: <https://1.ieee802.org/wp-content/uploads/2019/03/802-1AS-rev-d8-0.pdf>)

10.3.1.1 Best master clock algorithm overview

In the BMCA (i.e., method (a) of 10.3.1), best master selection information is exchanged between PTP Instances of time-aware systems via Announce messages (see 10.5 and 10.6). Each Announce message contains time-synchronization spanning tree vector information that identifies one PTP Instance as the root of the time-synchronization spanning tree and, if the PTP Instance is grandmaster-capable, the grandmaster. Each PTP Instance in turn uses the information contained in the Announce messages it receives, along with its knowledge of itself, to compute which of the PTP Instances that it has knowledge of ought to be the root of the spanning tree and, if grandmaster-capable, the grandmaster. As part of constructing the time-synchronization spanning tree, each port of each PTP Instance is assigned a port state from Table 10-2 by state machines associated with the ports and with the PTP Instance as a whole.

(Source: <https://1.ieee802.org/wp-content/uploads/2019/03/802-1AS-rev-d8-0.pdf>)

- c) In gPTP there are only two types of PTP Instances: PTP End Instances and PTP Relay Instances, while IEEE 1588 has ordinary clocks, boundary clocks, end-to-end transparent clocks, and P2P transparent clocks. A PTP End Instance corresponds to an IEEE 1588 ordinary clock, and a PTP Relay Instance is a type of IEEE 1588 boundary clock where its operation is very tightly defined, so much so that a PTP Relay Instance with Ethernet ports can be shown to be mathematically equivalent to a P2P transparent clock in terms of how synchronization is performed, as shown in

(Source: <https://1.ieee802.org/wp-content/uploads/2019/03/802-1AS-rev-d8-0.pdf>)

- **Grand Master selection**
 - GM-capable stations advertise themselves via ANNOUNCE messages
 - If a station hears from station with “better” clock, it does not send ANNOUNCE
 - Configurable “Priority” field can override clock quality
 - MAC address is tie breaker
 - Time relays drop all inferior ANNOUNCE messages
 - Forward only the best
 - Last one standing is Grand Master for the domain
 - GM is the root of the 802.1AS timing tree
 - GM periodically sends the current time

(Source: <https://avnu.org/wp-content/uploads/2014/05/as-kbstanton-8021AS-tutorial-0714-v01.pdf>)

IEEE Std 802.1Q-2018
IEEE Standard for Local and Metropolitan Area Networks—Bridges and Bridged Networks

2. Normative references

The following referenced documents are indispensable for the application of this document (i.e., they must be understood and used, so each referenced document is cited in the text and its relationship to this document is explained). For dated references, only the edition cited applies. For undated references, the latest edition of the referenced document (including any amendments or corrigenda) applies.

ANSI X3.159, American National Standards for Information Systems—Programming Language—C.⁵

IEEE Std 802[®], IEEE Standard for Local and metropolitan area networks: Overview and Architecture.^{6,7}

IEEE Std 802.1AB[™], IEEE Standard for Local and metropolitan area networks—Station and Media Access Control Connectivity Discovery.

IEEE Std 802.1AC[™], IEEE Standard for Local and metropolitan area networks—Media Access Control (MAC) Service Definition.

IEEE Std 802.1AE[™], IEEE Standard for Local and metropolitan area networks—Media Access Control (MAC) Security.

IEEE Std 802.1AS[™], IEEE Standard for Local and metropolitan area networks—Timing and Synchronization for Time-Sensitive Applications in Bridged Local Area Networks.

(Source: IEEE Standard for Local and Metropolitan Area Networks—Bridges and Bridged Networks- IEEE Std 802.1Q[™]-2018)

8.6.9.4.1 AdminBaseTime

The administrative value of base time, expressed as an IEEE 1588 precision time protocol (PTP) [B24] timescale (see 8.2 of IEEE Std 802.1AS™-2011 [B11]). This value can be changed by management, and is used by the List Config state machine (8.6.9.3) to set the value of OperBaseTime (8.6.9.4.18).

NOTE—Time is expressed in the PTP timescale as the number of seconds, nanoseconds, and fractional nanoseconds that have elapsed since 1 January 1970 00:00:00 TAI.

NOTE 2—If AdminBaseTime is set to the same time in the past in all bridges and end stations, OperBaseTime is always in the past, and all cycles start synchronized. Using AdminBaseTime in the past is appropriate when you can start schedules prior to starting the application that uses the schedules. Use of AdminBaseTime in the future is intended to change a currently running schedule in all bridges and end stations to a new schedule at a future time. Using AdminBaseTime in the future is appropriate when schedules must be changed without stopping the application.

(Source: IEEE Standard for Local and Metropolitan Area Networks—Bridges and Bridged Networks- IEEE Std 802.1Q™-2018)

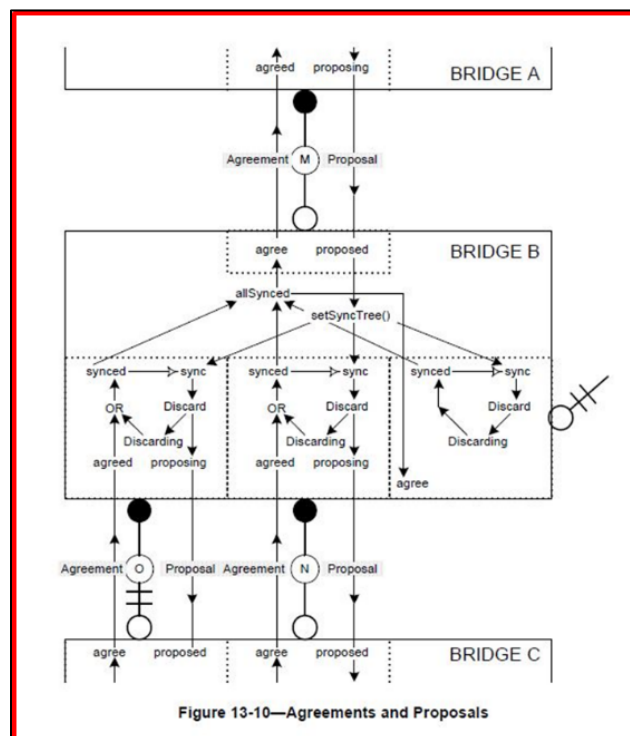

(Source: IEEE Standard for Local and Metropolitan Area Networks—Bridges and Bridged Networks- IEEE Std 802.1Q™-2018)

NOTE 2—Agreements can be generated without prior receipt of a Proposal as soon as the necessary conditions are met. Subsequent receipt of a Proposal serves to elicit a further Agreement. If all other ports have already been synchronized (allSynced in Figure 13-10) and the Proposal’s priority vector does not convey worse information, synchronization is maintained and there is no need to transition Designated Ports to Discarding once more, or to transmit further Proposals.

(Source: IEEE Standard for Local and Metropolitan Area Networks—Bridges and Bridged Networks- IEEE Std 802.1Q™-2018)

8.6.8.4 Enhancements for scheduled traffic

A Bridge or an end station may support enhancements that allow transmission from each queue to be scheduled relative to a known timescale. In order to achieve this, a transmission gate is associated with each queue; the state of the transmission gate determines whether or not queued frames can be selected for transmission (see Figure 8-12). For a given queue, the transmission gate can be in one of two states:

- a) Open: Queued frames are selected for transmission, in accordance with the definition of the transmission selection algorithm associated with the queue.
- b) Closed: Queued frames are not selected for transmission.

(Source: IEEE Standard for Local and metropolitan area networks— Bridges and Bridged Networks Amendment 25: Enhancements for Scheduled Traffic (IEEE 802.1Qbv-2015))

8.6.8 Transmission selection

For each Port, frames are selected for transmission on the basis of the traffic classes that the Port supports and the operation of the transmission selection algorithms supported by the corresponding queues on that Port. For a given Port and traffic class, frames are selected from the corresponding queue for transmission if and only if

- a) The operation of the transmission selection algorithm supported by that queue determines that there is a frame available for transmission; and
- b) For each queue corresponding to a numerically higher value of traffic class supported by the Port, the operation of the transmission selection algorithm supported by that queue determines that there is no frame available for transmission.

(Source: IEEE Standard for Local and Metropolitan Area Networks—Bridges and Bridged Networks- IEEE Std 802.1Q™-2018)

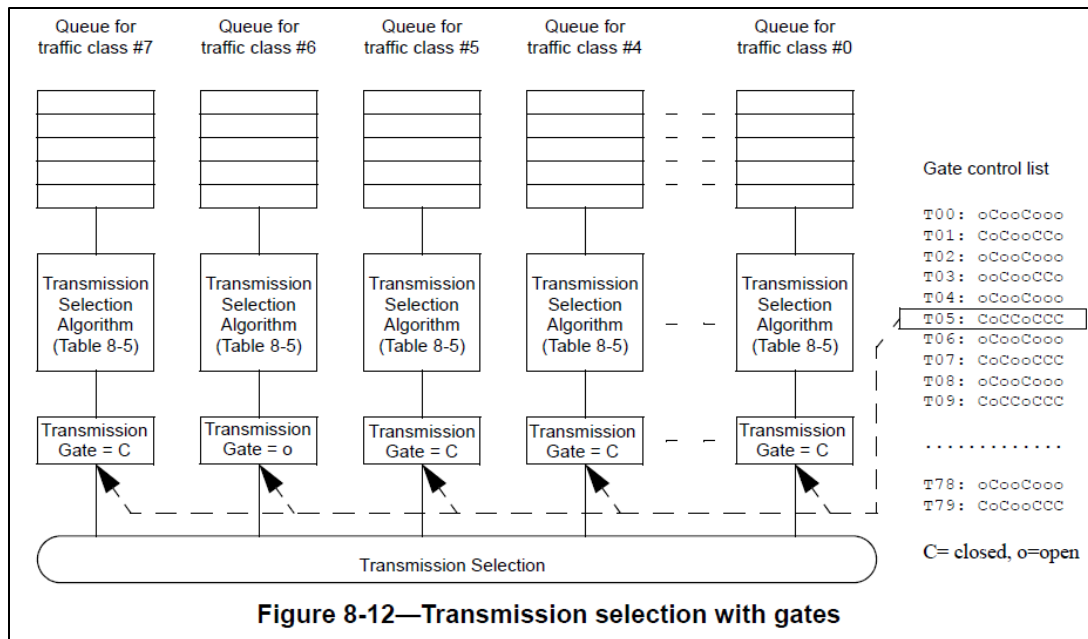

(Source: IEEE Standard for Local and metropolitan area networks— Bridges and Bridged Networks Amendment 25: Enhancements for Scheduled Traffic (IEEE 802.1Qbv-2015))

A gate control list associated with each Port contains an ordered list of gate operations. Each gate operation changes the transmission gate state for the gate associated with each of the Port's traffic class queues. In an implementation that does not support enhancements for scheduled traffic, all gates are assumed to be permanently in the open state. Table 8-6 identifies the gate operation types, their parameters, and the actions that result from their execution. The state machines that control the execution of the gate control list, along with their variables and procedures, are specified in 8.6.9.

(Source: IEEE Standard for Local and metropolitan area networks— Bridges and Bridged Networks Amendment 25: Enhancements for Scheduled Traffic (IEEE 802.1Qbv-2015)).

3.3 gating cycle: The period of time over which the sequence of operations in a gate control list repeats.

3.4 transmission gate: A gate that connects or disconnects the transmission selection function of the forwarding process from the queue, allowing or preventing it from selecting frames from that queue. The gate has two states, Open and Closed.

(Source: IEEE Standard for Local and metropolitan area networks— Bridges and Bridged Networks Amendment 25: Enhancements for Scheduled Traffic (IEEE 802.1Qbv-2015))

Cyclic queuing and forwarding⁵³

T.1 Overview of CQF

Cyclic queuing and forwarding (CQF) is a method of traffic shaping that can deliver deterministic, and easily calculated, latency for time-sensitive traffic streams. As the name implies, the principle underlying CQF is that stream traffic is transmitted and queued for transmission along a network path in a cyclic manner. Time is divided into numbered time intervals $i, i+1, i+2, \dots, i+N$, each of duration d . Frames transmitted by a Bridge, *Alice*, during time interval i are received by a downstream Bridge, *Bob*, during time interval i and are transmitted onwards by *Bob* towards Bridge *Charlie* during time interval $i+1$, and so on. A starting assumption is that, for a given traffic class, all Bridges and all end stations connected to a given bridge have a common understanding (to a known accuracy) of the start time of cycle i , and the cycle duration, d .

Frames transmitted by *Alice* during interval i are transmitted by *Bob* in interval $i+1$; the maximum possible delay experienced by a given frame is from the beginning of i to the end of $i+1$, or twice d . Similarly, the minimum possible delay experienced is from the end of i to the beginning of $i+1$, which is zero. More generally, the maximum delay experienced by a given frame is

$$(h+1) \times d$$

and the minimum delay experienced by a given frame is

$$(h-1) \times d$$

where h is the number of hops.

(Source: IEEE Standard for Local and Metropolitan Area Networks—Bridges and Bridged Networks- IEEE Std 802.1Q™-2018)

48. The accused products include a device adapter that is configured to transmit data during at least one of an assigned time phase associated with the device adapter prior to transmission of data from the real-time device by the device adapter, and included in the plurality of assigned time phases, or the free access phase, to refrain from transmitting data during time phases of the plurality of assigned time phases that are not associated with the device adapter, and to be able to determine whether to transmit or defer transmission of data during the assigned time phase associated with the device adapter and the free access phase to allow the another device to transmit data. For example, the accused products are configured to be used to implement the IEEE 802.1Q standard. IEEE standard 802.1Q shows that scheduling of ports' transmission gates for transmission of data starts prior to the transmission of real-time data. The

functionality of assigned time phases is achieved using open gates transmitting data packets during scheduled transmission time. Per Clause 8.6.8 of the IEEE Std. 802.1Q, each time phase is assigned to a specific device adapter prior to transmission of real-time data by the specific device adapter. Furthermore, IEEE 802.1Q performs traffic shaping through Per-Stream Filtering and Policing (PSTP). IEEE standard 802.1Q implements a method in which open gates transmit data packets during transmission time and closed gates refrain data packets from transmission. The functionality of assigned time phases is achieved using open gates transmitting data packets during transmission time. The functionality of free access phase is achieved by the gates that are opened for transmission during any time. IEEE Std. 802.1Q supports Forwarding and Queuing Enhancements for Time Sensitive Streams. Thus, one of the plurality of device adaptors is configured to transmit data during at least one of a respective assigned time phase or free access phase, to refrain from transmitting data during time phases not assigned to the respective one of the plurality of device adapters. IEEE Std. 802.1Q provides traffic shaping for various classes of data transmission and determining whether to transmit or defer transmission of data during at least one of the assigned time phase or the free access phase to allow the another device to transmit data.

NOTE 2—If AdminBaseTime is set to the same time in the past in all bridges and end stations, OperBaseTime is always in the past, and all cycles start synchronized. Using AdminBaseTime in the past is appropriate when you can start schedules prior to starting the application that uses the schedules. Use of AdminBaseTime in the future is intended to

(Source: IEEE Standard for Local and metropolitan area networks— Bridges and Bridged Networks Amendment 25: Enhancements for Scheduled Traffic (IEEE 802.1Qbv-2015))

1.1 Project Number: P802.1Qbv
1.2 Type of Document: Standard
1.3 Life Cycle: Full Use

5.5 Need for the Project: The credit-based shaper works well in arbitrary networks (i.e., non-engineered). Networks employing scheduled transmissions are able to control real-time processes. This amendment enables those two kinds of networks to be consolidated into a single network, with a significant cost reduction to the user.

(Source: <http://www.ieee802.org/1/files/public/docs2014/bv-p802-1Qbv-par-modification-1114.pdf>)

8.6.8 Transmission selection

For each Port, frames are selected for transmission on the basis of the traffic classes that the Port supports and the operation of the transmission selection algorithms supported by the corresponding queues on that Port. For a given Port and traffic class, frames are selected from the corresponding queue for transmission if and only if

- a) The operation of the transmission selection algorithm supported by that queue determines that there is a frame available for transmission; and
- b) For each queue corresponding to a numerically higher value of traffic class supported by the Port, the operation of the transmission selection algorithm supported by that queue determines that there is no frame available for transmission.

(Source: IEEE Standard for Local and Metropolitan Area Networks—Bridges and Bridged Networks- IEEE Std 802.1Q™-2018)

5.4.1.9 Cyclic queuing and forwarding (CQF) requirements

A VLAN Bridge component implementation that conforms to the provisions of this standard for CQF (see Annex T) shall

- a) Support the enhancements for scheduled traffic as specified in 8.6.8.4.
- b) Support the state machines for scheduled traffic as specified in 8.6.9.
- c) Support the state machines for stream gate control as specified in 8.6.10.
- d) Support the management entities for scheduled traffic as specified in 12.29.
- e) Support the requirements for per-stream filtering and policing (PSFP) as stated in 5.4.1.8.
- f) Support the management entities for PSFP as specified in 12.31.

(Source: IEEE Standard for Local and Metropolitan Area Networks—Bridges and Bridged Networks- IEEE Std 802.1Q™-2018)

5.4.1.5 Forwarding and Queuing Enhancements for time-sensitive streams (FQTSS)—requirements

A VLAN Bridge component implementation that conforms to the provisions of this standard for FQTSS shall

- a) Support a minimum of two traffic classes on all Ports, of which
 - 1) A minimum of one traffic class supports the strict priority algorithm for transmission selection (8.6.8.1), and
 - 2) One traffic class is a stream reservation (SR) class.
- b) Support the operation of the credit-based shaper algorithm (8.6.8.2) on all Ports as the transmission selection algorithm used for the SR class.
- c) Support SRP domain boundary port priority regeneration override as defined in 6.9.4, and the default priority regeneration override value defined in Table 6-5, for SR class "B."
- d) Support the tables and procedures for mapping priorities to traffic classes as defined in 34.5.

SR: Stream Reservation, SRP: Stream Reservation Protocol

(Source: IEEE Standard for Local and Metropolitan Area Networks—Bridges and Bridged Networks- IEEE Std 802.1Q™-2018)

8.6.8.4 Enhancements for scheduled traffic

A Bridge or an end station may support enhancements that allow transmission from each queue to be scheduled relative to a known timescale. In order to achieve this, a transmission gate is associated with each queue; the state of the transmission gate determines whether or not queued frames can be selected for transmission (see Figure 8-12). For a given queue, the transmission gate can be in one of two states:

- a) *Open*: Queued frames are selected for transmission, in accordance with the definition of the transmission selection algorithm associated with the queue.
- b) *Closed*: Queued frames are not selected for transmission.

(Source: IEEE Standard for Local and metropolitan area networks— Bridges and Bridged Networks Amendment 25: Enhancements for Scheduled Traffic (IEEE 802.1Qbv-2015))

A *gate control list* associated with each Port contains an ordered list of gate operations. Each gate operation changes the transmission gate state for the gate associated with each of the Port's traffic class queues. In an implementation that does not support enhancements for scheduled traffic, all gates are assumed to be permanently in the *open* state. Table 8-6 identifies the gate operation types, their parameters, and the actions that result from their execution. The state machines that control the execution of the gate control list, along with their variables and procedures, are specified in 8.6.9.

(Source: IEEE Standard for Local and metropolitan area networks— Bridges and Bridged Networks Amendment 25: Enhancements for Scheduled Traffic (IEEE 802.1Qbv-2015))

5.4.1.5 Forwarding and Queuing Enhancements for time-sensitive streams (FQTSS)—requirements

A VLAN Bridge component implementation that conforms to the provisions of this standard for FQTSS shall

- a) Support a minimum of two traffic classes on all Ports, of which
 - 1) A minimum of one traffic class supports the strict priority algorithm for transmission selection (8.6.8.1), and
 - 2) One traffic class is a stream reservation (SR) class.
- b) Support the operation of the credit-based shaper algorithm (8.6.8.2) on all Ports as the transmission selection algorithm used for the SR class.
- c) Support SRP domain boundary port priority regeneration override as defined in 6.9.4, and the default priority regeneration override value defined in Table 6-5, for SR class "B."
- d) Support the tables and procedures for mapping priorities to traffic classes as defined in 34.5.

SR: Stream Reservation, SRP: Stream Reservation Protocol

(Source: IEEE Standard for Local and Metropolitan Area Networks—Bridges and Bridged Networks- IEEE Std 802.1Q™-2018)

5.4.1.6 ETS Bridge requirements

A device supporting ETS shall

- a) Support at least 3 traffic classes (37.3).

NOTE—A minimum of 3 traffic classes allows a minimum configuration such that one traffic class contains priorities with PFC enabled, one traffic class contains priorities with PFC disabled, and one traffic class using strict priority.

- b) Support bandwidth configuration with a granularity of 1% or finer (37.3).
- c) Support bandwidth allocation with a precision of 10% (37.3).
- d) Support a transmission selection policy such that if one of the traffic classes does not consume its allocated bandwidth, then any unused bandwidth is available to other traffic classes (37.3).
- e) Support DCBX (Clause 38).

(Source: IEEE Standard for Local and Metropolitan Area Networks—Bridges and Bridged Networks- IEEE Std 802.1Q™-2018)

49. Analog has infringed the '504 Patent by using the accused products and thereby practicing a method that includes obtaining, at a device adapter, a substantially synchronized time frame which is maintained among a plurality of device adapters interconnected by a network, the time frame repeating periodically and including a plurality of assigned time phases and a free access phase. For example, the accused products are used by Analog to implement the

IEEE 802.1Q standard. IEEE standard 802.1Q implements a method in which a time aware bridged LAN transmits data from one end point i.e., Precision Time Protocol (PTP) instance to another. The endpoints transmit data that is a mix of time-critical traffic and other traffic, (i.e., real time data and non-real time data) via PTP instances such as bridges (device adapters). The end point can be either a real time device or a non-real time device. The bridged network uses 802.1AS base time to synchronize all the clocks of ports associated with bridges (device adapters). Using the Best Master Clock Algorithm, the synchronization time signal is transmitted from a grandmaster to other ports. IEEE Std. 802.1AS™-2011 is normative and essential to implement an IEEE Std. 802.1Q Compliant System. IEEE Std. 802.1Q-2018 defines parameters, such as AdminBaseTime and OpenBaseTime, which are used to synchronize the clocks across the network. The bridges containing ports schedule the transmission of traffic based on the synchronized time. Each port associated with a specific set of transmission queries includes a plurality of transmission gates. A transmission gate can be in a closed state or open state. The functionality of assigned time phases is achieved using open gates transmitting data packets during transmission time. The functionality of a free access phase is achieved when the gates are opened for transmission during any time. IEEE Std. 802.1Q-2018 supports cyclic queuing and forwarding structures to create synchronized frames and gates which repeat periodically (Annex T).

1.1 Project Number: P802.1Qbv
1.2 Type of Document: Standard
1.3 Life Cycle: Full Use

2.1 Title: Standard for Local and metropolitan area networks--Media Access Control (MAC) Bridges and Virtual Bridged Local Area Networks Amendment: Enhancements for Scheduled Traffic

5.2.b. Scope of the project: This amendment specifies time-aware queue-drawing procedures, managed objects and extensions to existing protocols that enable bridges and end stations to schedule the transmission of frames based on a synchronized time. Virtual Local Area Network (VLAN) tag encoded priority values are allocated allowing simultaneous support of scheduled traffic, credit-based shaper traffic and other bridged traffic over Local Area Networks (LANs).

(Source: <http://www.ieee802.org/1/files/public/docs2014/bv-p802-1Qbv-par-modification-1114.pdf>)

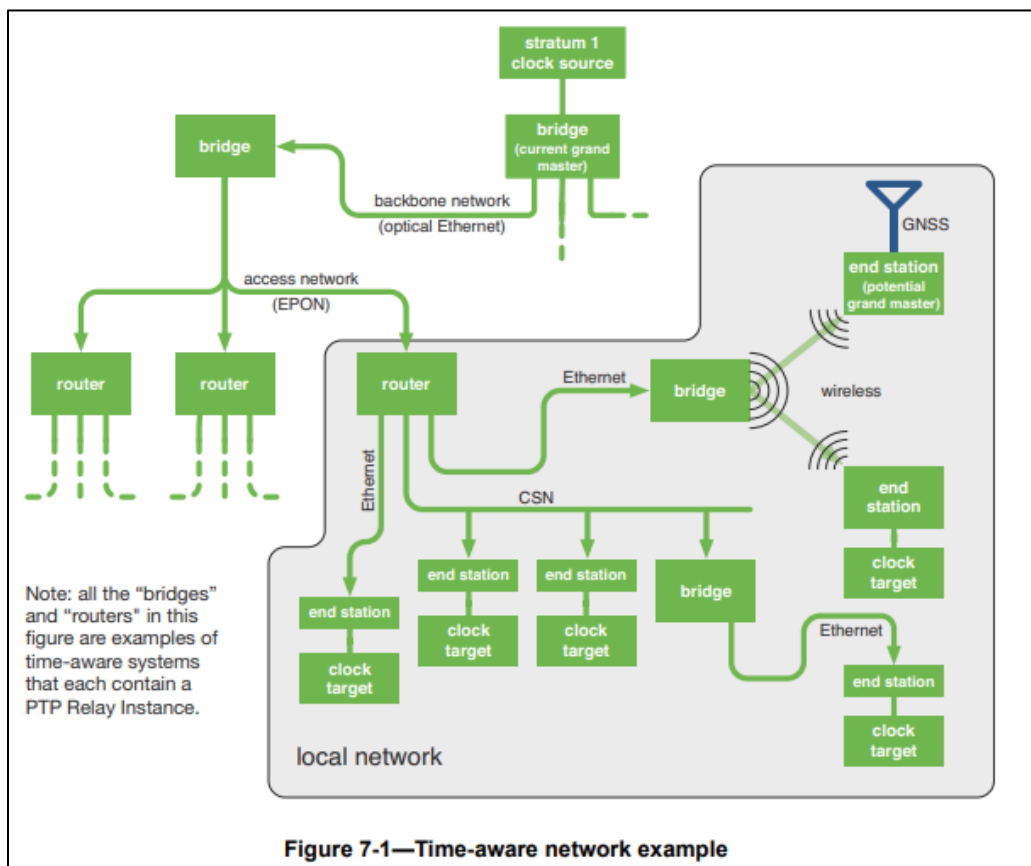

(Source: <https://1.ieee802.org/wp-content/uploads/2019/03/802-1AS-rev-d8-0.pdf>)

7.2 Architecture of a time-aware network

7.2.1 General

A time-aware network consists of a number of interconnected time-aware systems that support the gPTP defined within this standard. These time-aware systems can be any networking device, including, for example, bridges, routers, and end stations. A set of time-aware systems that are interconnected by gPTP-capable network elements is called a gPTP network. Each instance of gPTP that the time-aware systems support is in one *gPTP domain*, and the instances of gPTP are said to be part of that gPTP domain. A time-aware system can support, and therefore be part of, more than one gPTP domain. The entity of a single time-aware system that executes gPTP in one gPTP domain is called a PTP Instance. A time-aware system can contain multiple PTP Instances, which are each associated with a different gPTP domain. There are two

(Source: <https://1.ieee802.org/wp-content/uploads/2019/03/802-1AS-rev-d8-0.pdf>)

3.16 PTP End Instance: A PTP Instance that is capable of acting as the source of synchronized time on the network, or destination of synchronized time using the IEEE 802.1AS protocol, or both.

3.17 PTP Instance: A PTP Relay Instance or a PTP End Instance. A PTP Instance implements those portions of this standard indicated as applicable to a PTP Relay Instance or a PTP End Instance. Each PTP Instance operates in exactly one domain.

3.18 PTP Link: Within a domain, a network segment between two PTP Ports using the peer-to-peer delay mechanism of this standard. The peer-to-peer delay mechanism is designed to measure the propagation time over such a link.

NOTE—A PTP Link between PTP Ports of PTP Instances is also a gPTP Communication Path (see 3.9).

3.19 PTP Relay Instance: A PTP Instance that is capable of communicating synchronized time received on one port to other ports, using the IEEE 802.1AS protocol.

NOTE—A PTP Relay Instance could, for example, be contained in a bridge, a router, or a multi-port end station.

(Source: <https://1.ieee802.org/wp-content/uploads/2019/03/802-1AS-rev-d8-0.pdf>)

Traffic scheduling

This annex provides some background to the mechanisms provided in this standard for traffic scheduling, with the intent of providing some insight into the motivation for the provision of mechanisms for traffic scheduling and some of the ways that the mechanisms might be used.

Q.1 Motivation

Some applications have a need for frame delivery that is highly predictable in terms of the time at which frame transmission will occur, and the overall latency and jitter that will be experienced as the frame is propagated to its destination. Examples include industrial and automotive control applications, where data transmitted over the network is used to feed the parameters of control loops that are critical to the operation of the plant or machinery involved, and where frames carrying control data are transmitted on a repeating time schedule; late delivery of such frames can result in instability, inaccuracy, or failure of the operation of the control loops concerned. In some implementations, this need has been met by the provision of dedicated, highly engineered networks that are used solely for the transmission of time-critical control traffic; however, as the bandwidth occupied by such traffic is often low, and the cost of providing a dedicated control network can be high, it can be desirable to mix time-critical traffic with other classes of traffic in the same network, as long as such mixing can be achieved while still meeting the timing requirements of the time-critical traffic.

(Source: IEEE Standard for Local and metropolitan area networks— Bridges and Bridged Networks Amendment 25: Enhancements for Scheduled Traffic (IEEE 802.1Qbv-2015))

b) gPTP specifies a media-independent sublayer that simplifies the integration within a single timing domain of multiple different networking technologies with radically different media access protocols. gPTP specifies a media-dependent sublayer for each medium. The information exchanged between PTP Instances has been generalized to support different packet formats and management schemes appropriate to the particular networking technology. IEEE Std 1588-2019, on the other

(Source: <https://1.ieee802.org/wp-content/uploads/2019/03/802-1AS-rev-d8-0.pdf>)

7.2.2 Time-aware network consisting of a single gPTP domain

Figure 7-1 illustrates an example time-aware network consisting of a single gPTP domain, using all the above network technologies (i.e., (c) - (f) of 7.2.1), where end stations on several local networks are connected to a grandmaster on a backbone network via an EPON access network.

Any PTP Instance with clock sourcing capabilities can be a potential grandmaster, so there is a selection method (the *best master clock algorithm*, or BMCA) that ensures that all of the PTP Instances in a gPTP domain use the same grandmaster.¹² The BMCA is largely identical to that used in IEEE Std 1588-2019,

(Source: <https://1.ieee802.org/wp-content/uploads/2019/03/802-1AS-rev-d8-0.pdf>)

10.3.1.1 Best master clock algorithm overview

In the BMCA (i.e., method (a) of 10.3.1), best master selection information is exchanged between PTP Instances of time-aware systems via Announce messages (see 10.5 and 10.6). Each Announce message contains time-synchronization spanning tree vector information that identifies one PTP Instance as the root of the time-synchronization spanning tree and, if the PTP Instance is grandmaster-capable, the grandmaster. Each PTP Instance in turn uses the information contained in the Announce messages it receives, along with its knowledge of itself, to compute which of the PTP Instances that it has knowledge of ought to be the root of the spanning tree and, if grandmaster-capable, the grandmaster. As part of constructing the time-synchronization spanning tree, each port of each PTP Instance is assigned a port state from Table 10-2 by state machines associated with the ports and with the PTP Instance as a whole.

(Source: <https://1.ieee802.org/wp-content/uploads/2019/03/802-1AS-rev-d8-0.pdf>)

c) In gPTP there are only two types of PTP Instances: PTP End Instances and PTP Relay Instances, while IEEE 1588 has ordinary clocks, boundary clocks, end-to-end transparent clocks, and P2P transparent clocks. A PTP End Instance corresponds to an IEEE 1588 ordinary clock, and a PTP Relay Instance is a type of IEEE 1588 boundary clock where its operation is very tightly defined, so much so that a PTP Relay Instance with Ethernet ports can be shown to be mathematically equivalent to a P2P transparent clock in terms of how synchronization is performed, as shown in

(Source: <https://1.ieee802.org/wp-content/uploads/2019/03/802-1AS-rev-d8-0.pdf>)

• Grand Master selection

- GM-capable stations advertise themselves via ANNOUNCE messages
- If a station hears from station with “better” clock, it does not send ANNOUNCE
 - Configurable “Priority” field can override clock quality
 - MAC address is tie breaker
- Time relays drop all inferior ANNOUNCE messages
 - Forward only the best
- Last one standing is Grand Master for the domain
 - GM is the root of the 802.1AS timing tree
 - GM periodically sends the current time

(Source: <https://avnu.org/wp-content/uploads/2014/05/as-kbstanton-8021AS-tutorial-0714-v01.pdf>)

IEEE Std 802.1Q-2018
IEEE Standard for Local and Metropolitan Area Networks—Bridges and Bridged Networks

2. Normative references

The following referenced documents are indispensable for the application of this document (i.e., they must be understood and used, so each referenced document is cited in the text and its relationship to this document is explained). For dated references, only the edition cited applies. For undated references, the latest edition of the referenced document (including any amendments or corrigenda) applies.

ANSI X3.159, American National Standards for Information Systems—Programming Language—C.⁵

IEEE Std 802[®], IEEE Standard for Local and metropolitan area networks: Overview and Architecture.^{6,7}

IEEE Std 802.1AB[™], IEEE Standard for Local and metropolitan area networks—Station and Media Access Control Connectivity Discovery.

IEEE Std 802.1AC[™], IEEE Standard for Local and metropolitan area networks—Media Access Control (MAC) Service Definition.

IEEE Std 802.1AE[™], IEEE Standard for Local and metropolitan area networks—Media Access Control (MAC) Security.

IEEE Std 802.1AS[™], IEEE Standard for Local and metropolitan area networks—Timing and Synchronization for Time-Sensitive Applications in Bridged Local Area Networks.

(Source: IEEE Standard for Local and metropolitan area networks— Bridges and Bridged Networks Amendment 25: Enhancements for Scheduled Traffic (IEEE 802.1Qbv-2015))

8.6.9.4.1 AdminBaseTime

The administrative value of base time, expressed as an IEEE 1588 precision time protocol (PTP) [B24] timescale (see 8.2 of IEEE Std 802.1AS[™]-2011 [B11]). This value can be changed by management, and is used by the List Config state machine (8.6.9.3) to set the value of OperBaseTime (8.6.9.4.18).

NOTE—Time is expressed in the PTP timescale as the number of seconds, nanoseconds, and fractional nanoseconds that have elapsed since 1 January 1970 00:00:00 TAI.

NOTE 2—If AdminBaseTime is set to the same time in the past in all bridges and end stations, OperBaseTime is always in the past, and all cycles start synchronized. Using AdminBaseTime in the past is appropriate when you can start schedules prior to starting the application that uses the schedules. Use of AdminBaseTime in the future is intended to change a currently running schedule in all bridges and end stations to a new schedule at a future time. Using AdminBaseTime in the future is appropriate when schedules must be changed without stopping the application.

(Source: IEEE Standard for Local and metropolitan area networks— Bridges and Bridged Networks Amendment 25: Enhancements for Scheduled Traffic (IEEE 802.1Qbv-2015))

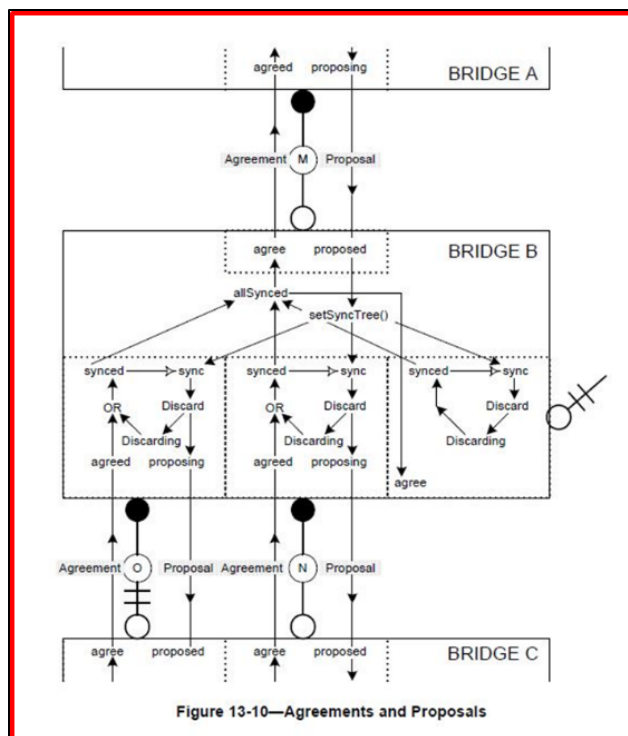

(Source: IEEE Standard for Local and Metropolitan Area Networks—Bridges and Bridged Networks- IEEE Std 802.1Q™-2018)

NOTE 2—Agreements can be generated without prior receipt of a Proposal as soon as the necessary conditions are met. Subsequent receipt of a Proposal serves to elicit a further Agreement. If all other ports have already been synchronized (allSynced in Figure 13-10) and the Proposal's priority vector does not convey worse information, synchronization is maintained and there is no need to transition Designated Ports to Discarding once more, or to transmit further Proposals.

(Source: IEEE Standard for Local and Metropolitan Area Networks—Bridges and Bridged Networks- IEEE Std 802.1Q™-2018)

8.6.8.4 Enhancements for scheduled traffic

A Bridge or an end station may support enhancements that allow transmission from each queue to be scheduled relative to a known timescale. In order to achieve this, a transmission gate is associated with each queue; the state of the transmission gate determines whether or not queued frames can be selected for transmission (see Figure 8-12). For a given queue, the transmission gate can be in one of two states:

- a) Open: Queued frames are selected for transmission, in accordance with the definition of the transmission selection algorithm associated with the queue.
- b) Closed: Queued frames are not selected for transmission.

(Source: IEEE Standard for Local and metropolitan area networks— Bridges and Bridged Networks Amendment 25: Enhancements for Scheduled Traffic (IEEE 802.1Qbv-2015))

8.6.8 Transmission selection

For each Port, frames are selected for transmission on the basis of the traffic classes that the Port supports and the operation of the transmission selection algorithms supported by the corresponding queues on that Port. For a given Port and traffic class, frames are selected from the corresponding queue for transmission if and only if

- a) The operation of the transmission selection algorithm supported by that queue determines that there is a frame available for transmission; and
- b) For each queue corresponding to a numerically higher value of traffic class supported by the Port, the operation of the transmission selection algorithm supported by that queue determines that there is no frame available for transmission.

(Source: IEEE Standard for Local and Metropolitan Area Networks—Bridges and Bridged Networks- IEEE Std 802.1Q™-2018)

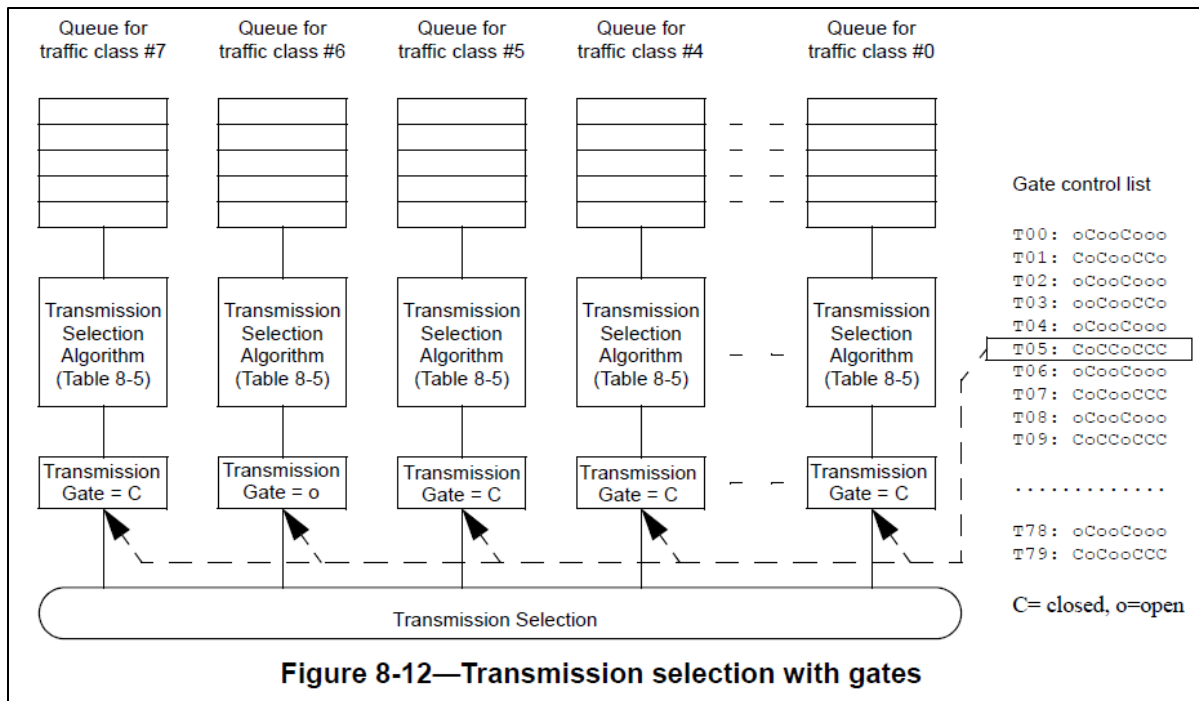

(Source: IEEE Standard for Local and metropolitan area networks— Bridges and Bridged Networks Amendment 25: Enhancements for Scheduled Traffic (IEEE 802.1Qbv-2015))

A gate control list associated with each Port contains an ordered list of gate operations. Each gate operation changes the transmission gate state for the gate associated with each of the Port's traffic class queues. In an implementation that does not support enhancements for scheduled traffic, all gates are assumed to be permanently in the open state. Table 8-6 identifies the gate operation types, their parameters, and the actions that result from their execution. The state machines that control the execution of the gate control list, along with their variables and procedures, are specified in 8.6.9.

(Source: IEEE Standard for Local and metropolitan area networks— Bridges and Bridged Networks Amendment 25: Enhancements for Scheduled Traffic (IEEE 802.1Qbv-2015))

3.3 gating cycle: The period of time over which the sequence of operations in a gate control list repeats.

3.4 transmission gate: A gate that connects or disconnects the transmission selection function of the forwarding process from the queue, allowing or preventing it from selecting frames from that queue. The gate has two states, Open and Closed.

(Source: IEEE Standard for Local and metropolitan area networks— Bridges and Bridged Networks Amendment 25: Enhancements for Scheduled Traffic (IEEE 802.1Qbv-2015))

Cyclic queuing and forwarding⁵³

T.1 Overview of CQF

Cyclic queuing and forwarding (CQF) is a method of traffic shaping that can deliver deterministic, and easily calculated, latency for time-sensitive traffic streams. As the name implies, the principle underlying CQF is that stream traffic is transmitted and queued for transmission along a network path in a cyclic manner. Time is divided into numbered time intervals $i, i+1, i+2, \dots, i+N$, each of duration d . Frames transmitted by a Bridge, *Alice*, during time interval i are received by a downstream Bridge, *Bob*, during time interval i and are transmitted onwards by *Bob* towards Bridge *Charlie* during time interval $i+1$, and so on. A starting assumption is that, for a given traffic class, all Bridges and all end stations connected to a given bridge have a common understanding (to a known accuracy) of the start time of cycle i , and the cycle duration, d .

Frames transmitted by *Alice* during interval i are transmitted by *Bob* in interval $i+1$; the maximum possible delay experienced by a given frame is from the beginning of i to the end of $i+1$, or twice d . Similarly, the minimum possible delay experienced is from the end of i to the beginning of $i+1$, which is zero. More generally, the maximum delay experienced by a given frame is

$$(h+1) \times d$$

and the minimum delay experienced by a given frame is

$$(h-1) \times d$$

where h is the number of hops.

(Source: IEEE Standard for Local and Metropolitan Area Networks—Bridges and Bridged Networks- IEEE Std 802.1Q™-2018)

50. The methods practiced by Analog's use of the accused products include controlling transmission of data during at least one of an assigned time phase assigned to the device adapter prior to transmission of real-time data by the device adapter, and included in the plurality of assigned time phases, or the free access phase. For example, the accused products are used by Analog to implement the IEEE 802.1Q standard. IEEE standard 802.1Q shows that scheduling (controlling) of transmission gates ports for transmission of data starts prior to the transmission of real-time data. The functionality of assigned time phases is achieved using open gates transmitting data packets during scheduled transmission time. Per Clause 8.6.8 of the IEEE Std. 802.1Q, each time phase is assigned to a specific device adapter prior to transmission of real-time data by the specific device adapter. IEEE 802.1Q performs traffic shaping through

Per-Stream Filtering and Policing (PSFP). In IEEE 802.1Q, open gates transmit data packets during transmission time and closed gates refrain data packets from transmission. The functionality of assigned time phases is achieved using open gates transmitting data packets during transmission time. The functionality of free access phase is achieved by the gates that are opened for transmission during any time. IEEE Std. 802.1Q supports Forwarding and Queuing Enhancements for Time Sensitive Streams. The ports of device adapters are assigned a time for transmission based on priority and credit-based algorithm. So, there will be instances when the transmission of data is refrained based on priority. Thus, one of the plurality of devices is configured to transmit data during at least one of a respective assigned time phase or free access phase, to refrain from transmitting data during time phases not assigned to the respective one of the plurality of device adapters. IEEE Std. 802.1Q provides traffic shaping for various classes of data transmission and determining whether to defer transmission of data during at least one of the assigned time phase or the free access phase to allow a non-real time device to transmit data.

NOTE 2—If AdminBaseTime is set to the same time in the past in all bridges and end stations, OperBaseTime is always in the past, and all cycles start synchronized. Using AdminBaseTime in the past is appropriate when you can start schedules prior to starting the application that uses the schedules. Use of AdminBaseTime in the future is intended to

(Source: IEEE Standard for Local and metropolitan area networks— Bridges and Bridged Networks Amendment 25: Enhancements for Scheduled Traffic (IEEE 802.1Qbv-2015))

1.1 Project Number: P802.1Qbv
1.2 Type of Document: Standard
1.3 Life Cycle: Full Use

5.5 Need for the Project: The credit-based shaper works well in arbitrary networks (i.e., non-engineered). Networks employing scheduled transmissions are able to control real-time processes. This amendment enables those two kinds of networks to be consolidated into a single network, with a significant cost reduction to the user.

(Source: <http://www.ieee802.org/1/files/public/docs2014/bv-p802-1Qbv-par-modification-1114.pdf>)

8.6.8 Transmission selection

For each Port, frames are selected for transmission on the basis of the traffic classes that the Port supports and the operation of the transmission selection algorithms supported by the corresponding queues on that Port. For a given Port and traffic class, frames are selected from the corresponding queue for transmission if and only if

- a) The operation of the transmission selection algorithm supported by that queue determines that there is a frame available for transmission; and
- b) For each queue corresponding to a numerically higher value of traffic class supported by the Port, the operation of the transmission selection algorithm supported by that queue determines that there is no frame available for transmission.

(Source: IEEE Standard for Local and Metropolitan Area Networks—Bridges and Bridged Networks- IEEE Std 802.1Q™-2018)

5.4.1.9 Cyclic queuing and forwarding (CQF) requirements

A VLAN Bridge component implementation that conforms to the provisions of this standard for CQF (see Annex T) shall

- a) Support the enhancements for scheduled traffic as specified in 8.6.8.4.
- b) Support the state machines for scheduled traffic as specified in 8.6.9.
- c) Support the state machines for stream gate control as specified in 8.6.10.
- d) Support the management entities for scheduled traffic as specified in 12.29.
- e) Support the requirements for per-stream filtering and policing (PSFP) as stated in 5.4.1.8.
- f) Support the management entities for PSFP as specified in 12.31.

(Source: IEEE Standard for Local and Metropolitan Area Networks—Bridges and Bridged Networks- IEEE Std 802.1Q™-2018)

5.4.1.5 Forwarding and Queuing Enhancements for time-sensitive streams (FQTSS)—requirements

A VLAN Bridge component implementation that conforms to the provisions of this standard for FQTSS shall

- a) Support a minimum of two traffic classes on all Ports, of which
 - 1) A minimum of one traffic class supports the strict priority algorithm for transmission selection (8.6.8.1), and
 - 2) One traffic class is a stream reservation (SR) class.
- b) Support the operation of the credit-based shaper algorithm (8.6.8.2) on all Ports as the transmission selection algorithm used for the SR class.
- c) Support SRP domain boundary port priority regeneration override as defined in 6.9.4, and the default priority regeneration override value defined in Table 6-5, for SR class “B.”
- d) Support the tables and procedures for mapping priorities to traffic classes as defined in 34.5.

SR: Stream Reservation, SRP: Stream Reservation Protocol

(Source: IEEE Standard for Local and Metropolitan Area Networks—Bridges and Bridged Networks- IEEE Std 802.1Q™-2018)

8.6.8.4 Enhancements for scheduled traffic

A Bridge or an end station may support enhancements that allow transmission from each queue to be scheduled relative to a known timescale. In order to achieve this, a transmission gate is associated with each queue; the state of the transmission gate determines whether or not queued frames can be selected for transmission (see Figure 8-12). For a given queue, the transmission gate can be in one of two states:

- a) Open: Queued frames are selected for transmission, in accordance with the definition of the transmission selection algorithm associated with the queue.
- b) Closed: Queued frames are not selected for transmission.

(Source: IEEE Standard for Local and metropolitan area networks— Bridges and Bridged Networks Amendment 25: Enhancements for Scheduled Traffic (IEEE 802.1Qbv-2015))

A gate control list associated with each Port contains an ordered list of gate operations. Each gate operation changes the transmission gate state for the gate associated with each of the Port's traffic class queues. In an implementation that does not support enhancements for scheduled traffic, all gates are assumed to be permanently in the open state. Table 8-6 identifies the gate operation types, their parameters, and the actions that result from their execution. The state machines that control the execution of the gate control list, along with their variables and procedures, are specified in 8.6.9.

(Source: IEEE Standard for Local and metropolitan area networks— Bridges and Bridged Networks Amendment 25: Enhancements for Scheduled Traffic (IEEE 802.1Qbv-2015))

5.4.1.6 ETS Bridge requirements

A device supporting ETS shall

- a) Support at least 3 traffic classes (37.3).

NOTE—A minimum of 3 traffic classes allows a minimum configuration such that one traffic class contains priorities with PFC enabled, one traffic class contains priorities with PFC disabled, and one traffic class using strict priority.

- b) Support bandwidth configuration with a granularity of 1% or finer (37.3).
- c) Support bandwidth allocation with a precision of 10% (37.3).
- d) Support a transmission selection policy such that if one of the traffic classes does not consume its allocated bandwidth, then any unused bandwidth is available to other traffic classes (37.3).
- e) Support DCBX (Clause 38).

(Source: IEEE Standard for Local and Metropolitan Area Networks—Bridges and Bridged Networks- IEEE Std 802.1Q™-2018)

51. The methods practiced by Analog's use of the accused products include refraining from transmitting data during time phases of the plurality of assigned time phases that are not associated with the device adapter. For example, the accused products are used by Analog to implement the IEEE 802.1Q standard. IEEE standard 802.1Q performs traffic shaping through Per-Stream Filtering and Policing (PSFP). In IEEE 802.1Q, open gates transmit data packets during transmission time and closed gates refrain data packets from transmission. The functionality of assigned time phases is achieved using open gates transmitting data packets during transmission time. The functionality of free access phase is achieved by the gates that are opened for transmission during any time. IEEE Std. 802.1Q supports Forwarding and Queuing Enhancements for Time Sensitive Streams. The ports of device adapters are assigned a time for transmission based on priority and credit-based algorithm. So, there are instances when the transmission of data is refrained based on priority. Thus, one of the plurality of devices is configured to transmit data during at least one of a respective assigned time phase or free access phase, to refrain from transmitting data during time phases not assigned to the respective one of the plurality of device adapters.

5.4.1.9 Cyclic queuing and forwarding (CQF) requirements

A VLAN Bridge component implementation that conforms to the provisions of this standard for CQF (see Annex T) shall

- a) Support the enhancements for scheduled traffic as specified in 8.6.8.4.
- b) Support the state machines for scheduled traffic as specified in 8.6.9.
- c) Support the state machines for stream gate control as specified in 8.6.10.
- d) Support the management entities for scheduled traffic as specified in 12.29.
- e) Support the requirements for per-stream filtering and policing (PSFP) as stated in 5.4.1.8.
- f) Support the management entities for PSFP as specified in 12.31.

(Source: IEEE Standard for Local and Metropolitan Area Networks—Bridges and Bridged Networks- IEEE Std 802.1Q™-2018)

5.4.1.5 Forwarding and Queuing Enhancements for time-sensitive streams (FQTSS)—requirements

A VLAN Bridge component implementation that conforms to the provisions of this standard for FQTSS shall

- a) Support a minimum of two traffic classes on all Ports, of which
 - 1) A minimum of one traffic class supports the strict priority algorithm for transmission selection (8.6.8.1), and
 - 2) One traffic class is a stream reservation (SR) class.
- b) Support the operation of the credit-based shaper algorithm (8.6.8.2) on all Ports as the transmission selection algorithm used for the SR class.
- c) Support SRP domain boundary port priority regeneration override as defined in 6.9.4, and the default priority regeneration override value defined in Table 6-5, for SR class “B.”
- d) Support the tables and procedures for mapping priorities to traffic classes as defined in 34.5.

SR: Stream Reservation, SRP: Stream Reservation Protocol

(Source: IEEE Standard for Local and Metropolitan Area Networks—Bridges and Bridged Networks- IEEE Std 802.1Q™-2018)

8.6.8.4 Enhancements for scheduled traffic

A Bridge or an end station may support enhancements that allow transmission from each queue to be scheduled relative to a known timescale. In order to achieve this, a transmission gate is associated with each queue; the state of the transmission gate determines whether or not queued frames can be selected for transmission (see Figure 8-12). For a given queue, the transmission gate can be in one of two states:

- a) Open: Queued frames are selected for transmission, in accordance with the definition of the transmission selection algorithm associated with the queue.
- b) Closed: Queued frames are not selected for transmission.

(Source: IEEE Standard for Local and metropolitan area networks— Bridges and Bridged Networks Amendment 25: Enhancements for Scheduled Traffic (IEEE 802.1Qbv-2015))

A gate control list associated with each Port contains an ordered list of gate operations. Each gate operation changes the transmission gate state for the gate associated with each of the Port’s traffic class queues. In an implementation that does not support enhancements for scheduled traffic, all gates are assumed to be permanently in the open state. Table 8-6 identifies the gate operation types, their parameters, and the actions that result from their execution. The state machines that control the execution of the gate control list, along with their variables and procedures, are specified in 8.6.9.

(Source: IEEE Standard for Local and metropolitan area networks— Bridges and Bridged Networks Amendment 25: Enhancements for Scheduled Traffic (IEEE 802.1Qbv-2015))

5.4.1.5 Forwarding and Queuing Enhancements for time-sensitive streams (FQTSS)—requirements

A VLAN Bridge component implementation that conforms to the provisions of this standard for FQTSS shall

- a) Support a minimum of two traffic classes on all Ports, of which
 - 1) A minimum of one traffic class supports the strict priority algorithm for transmission selection (8.6.8.1), and
 - 2) One traffic class is a stream reservation (SR) class.
- b) Support the operation of the credit-based shaper algorithm (8.6.8.2) on all Ports as the transmission selection algorithm used for the SR class.
- c) Support SRP domain boundary port priority regeneration override as defined in 6.9.4, and the default priority regeneration override value defined in Table 6-5, for SR class "B."
- d) Support the tables and procedures for mapping priorities to traffic classes as defined in 34.5.

SR: Stream Reservation, SRP: Stream Reservation Protocol

(Source: IEEE Standard for Local and Metropolitan Area Networks—Bridges and Bridged Networks- IEEE Std 802.1Q™-2018)

52. The plurality of device adaptors recited above in connection with Analog's use of the accused products includes determining whether to defer transmission of data during the assigned time phase assigned to the device adapter if the device adapter has data to transmit during the assigned time phase assigned to the device adapter, to allow another device to transmit data during the assigned time phase assigned to the device adapter; and determining whether to defer transmission of data during the free access phase if the device adapter has data to transmit during the free access phase, to allow the another device to transmit data during the free access phase. For example, the accused products are used by Analog to implement the IEEE 802.1Q standard. IEEE standard 802.1Q implements a method in which open gates transmit data packets during transmission time and closed gates refrain data packets from transmission. The functionality of assigned time phases is achieved using open gates transmitting data packets during transmission time. The functionality of free access phase is achieved by the gates that are opened for transmission during any time. IEEE Std. 802.1Q supports Forwarding and Queuing Enhancements for Time Sensitive Streams. The ports of device adapters are assigned a time for

transmission based on priority and credit-based algorithm. So, there will be instances when the transmission of data is refrained based on priority. Thus, one of the plurality of devices is configured to transmit data during at least one of a respective assigned time phase or free access phase, to refrain from transmitting data during time phases not assigned to the respective one of the plurality of device adapters. IEEE Std. 802.1Q provides traffic shaping for various classes of data transmission and determining whether to defer transmission of data during at least one of the assigned time phase or the free access phase to allow another device (non-real time device) to transmit data.

8.6.8.4 Enhancements for scheduled traffic

A Bridge or an end station may support enhancements that allow transmission from each queue to be scheduled relative to a known timescale. In order to achieve this, a transmission gate is associated with each queue; the state of the transmission gate determines whether or not queued frames can be selected for transmission (see Figure 8-12). For a given queue, the transmission gate can be in one of two states:

- a) *Open*: Queued frames are selected for transmission, in accordance with the definition of the transmission selection algorithm associated with the queue.
- b) *Closed*: Queued frames are not selected for transmission.

(Source: IEEE Standard for Local and metropolitan area networks— Bridges and Bridged Networks Amendment 25: Enhancements for Scheduled Traffic (IEEE 802.1Qbv-2015))

A gate control list associated with each Port contains an ordered list of gate operations. Each gate operation changes the transmission gate state for the gate associated with each of the Port's traffic class queues. In an implementation that does not support enhancements for scheduled traffic, all gates are assumed to be permanently in the *open* state. Table 8-6 identifies the gate operation types, their parameters, and the actions that result from their execution. The state machines that control the execution of the gate control list, along with their variables and procedures, are specified in 8.6.9.

(Source: IEEE Standard for Local and metropolitan area networks— Bridges and Bridged Networks Amendment 25: Enhancements for Scheduled Traffic (IEEE 802.1Qbv-2015))

5.4.1.5 Forwarding and Queuing Enhancements for time-sensitive streams (FQTSS)—requirements

A VLAN Bridge component implementation that conforms to the provisions of this standard for FQTSS shall

- a) Support a minimum of two traffic classes on all Ports, of which
 - 1) A minimum of one traffic class supports the strict priority algorithm for transmission selection (8.6.8.1), and
 - 2) One traffic class is a stream reservation (SR) class.
- b) Support the operation of the credit-based shaper algorithm (8.6.8.2) on all Ports as the transmission selection algorithm used for the SR class.
- c) Support SRP domain boundary port priority regeneration override as defined in 6.9.4, and the default priority regeneration override value defined in Table 6-5, for SR class "B."
- d) Support the tables and procedures for mapping priorities to traffic classes as defined in 34.5.

SR: Stream Reservation, SRP: Stream Reservation Protocol

(Source: IEEE Standard for Local and Metropolitan Area Networks—Bridges and Bridged Networks- IEEE Std 802.1Q™-2018)

5.4.1.6 ETS Bridge requirements

A device supporting ETS shall

- a) Support at least 3 traffic classes (37.3).

NOTE—A minimum of 3 traffic classes allows a minimum configuration such that one traffic class contains priorities with PFC enabled, one traffic class contains priorities with PFC disabled, and one traffic class using strict priority.

- b) Support bandwidth configuration with a granularity of 1% or finer (37.3).
- c) Support bandwidth allocation with a precision of 10% (37.3).
- d) Support a transmission selection policy such that if one of the traffic classes does not consume its allocated bandwidth, then any unused bandwidth is available to other traffic classes (37.3).
- e) Support DCBX (Clause 38).

(Source: IEEE Standard for Local and Metropolitan Area Networks—Bridges and Bridged Networks- IEEE Std 802.1Q™-2018)

53. Far North Patents has been damaged as a result of the infringing conduct by Analog alleged above. Thus, Analog is liable to Far North Patents in an amount that adequately compensates it for such infringements, which, by law, cannot be less than a reasonable royalty, together with interest and costs as fixed by this Court under 35 U.S.C. § 284.

54. Far North Patents and/or its predecessors-in-interest have satisfied all statutory obligations required to collect pre-filing damages for the full period allowed by law for infringement of the ‘504 Patent.

COUNT V

DIRECT INFRINGEMENT OF U.S. PATENT NO. 6,661,804

55. On December 9, 2003, United States Patent No. 6,661,804 (“the ‘804 Patent”) was duly and legally issued by the United States Patent and Trademark Office for an invention entitled “Methods and Apparatus for Providing Quality-of-Service Guarantees in Computer Networks.”

56. Far North Patents is the owner of the ‘804 Patent, with all substantive rights in and to that patent, including the sole and exclusive right to prosecute this action and enforce the ‘804 Patent against infringers, and to collect damages for all relevant times.

57. Analog made, had made, used, imported, provided, supplied, distributed, sold, and/or offered for sale products and/or systems including, for example, its Analog Fido5000 REM switch family (5100/5200) and its Analog EVAL-RapID-TSNEK TSN Evaluation Kit families of products that include advanced quality of service capabilities (collectively, “accused products”).

ANALOG DEVICES
AHEAD OF WHAT'S POSSIBLE™

Search

MYANALOG | MY HISTORY | **PRODUCTS** | APPLICATIONS | DESIGN CENTER | EDUCATION | SUPPORT

Products > Industrial Ethernet > Industrial Ethernet Embedded Switches

Print myAnalog

Industrial Ethernet Embedded Switches

REM Switch Family Supports All Major Industrial Ethernet Protocols and Connects to Any Processor to Build Any Field Device or Controller Application.

The fido5000 REM switch family includes two 2-port, Industrial Ethernet embedded switches that interface to any processor, including any ARM® CPU and ADI's fido1100 communication controller. ADI's PriorityChannel™ technology has been integrated into their hardware architecture and designed into the REM switch software drivers. The protocols supported by these switches are PROFINET Class C (IRT) and Class B (RT), EtherNet/IP® with and without DLR, Modbus® TCP, EtherCAT®, and POWERLINK®. The REM switches come with a software driver for each protocol. The software drivers provide an API for integration with any field device or controller protocol stack. ADI is certifying REM and its software drivers at each protocol's sponsoring industry organization using ADI's RapID platform.



fido5100 data sheet, specs and more



fido5200 data sheet, specs, and more

(Source : <https://www.analog.com/en/products/industrial-ethernet/industrial-ethernet-embedded-switches.html>)

Embedded Switches

	Port Count	Protocol Support	TSN Features	Package	Power
fido5100	2	PROFINET, Ethernet/IP®, POWERLINK®, Modbus® TCP	802.1AS (Time synchronization); 802.1Qbv (Scheduled traffic); 802.1CB (Redundancy); 802.1Qcc (Configuration)	144-ball, 10 mm × 10 mm CSP_BGA	160 mW
fido5200	2	EtherCAT®, PROFINET, Ethernet/IP, POWERLINK, Modbus TCP	802.1AS (Time synchronization); 802.1Qbv (Scheduled traffic); 802.1CB (Redundancy); 802.1Qcc (Configuration)	144-ball, 10 mm × 10 mm CSP_BGA	160 mW

(Source : screenshot of PDF downloaded from <https://www.analog.com/media/en/news-marketing-collateral/solutions-bulletins-brochures/scalable-ethernet-timed-to-perfection.pdf>)

(Source : <https://www.analog.com/en/design-center/evaluation-hardware-and-software/evaluation-boards-kits/eval-rapid-tsnek.html#eb-overview>)

Product Details

The TSN Evaluation Kit is configured to provide TSN Gateway functionality in order to quickly assess TSN features and capabilities and better understand how TSN works. From there, it is possible to utilize fido5000 Real-time Ethernet Multi-protocol (REM) Switch chip to provide a TSN solution in your product's application. The figure below shows how the TSN Kit architecture relates to a "partitioned" communication architecture and to an "integrated" communications architecture.

Using the TSN gateway functionality allows a non-TSN device to participate in a TSN network without implementing TSN-specific features natively. The TSN gateway has built-in features from the following IEEE specifications:

- 802.1AS, AS-REV – Time Synchronization
- 802.1Qbv – Scheduled Traffic
- 802.1Qci – Ingress Policing
- 802.1CB – Seamless Redundancy
- 802.1Qcc – Stream Reservation Protocol
- 802.1Qbu / 802.3br – Preemption

The TSN gateway comes pre-installed with software that supports 802.1AS, 802.1Qbv, 802.1Qcc, and stream translation. Software updates will be provided to add TSN features and correct any interoperability issues. 802.1Qcc is currently implemented using a webserver, but will ultimately be implemented so the gateway can be configured by a Central Network Controller (CNC).

(Source : <https://www.analog.com/en/design-center/evaluation-hardware-and-software/evaluation-boards-kits/eval-rapid-tsnek.html#eb-overview>)

58. By doing so, Analog has directly infringed (literally and/or under the doctrine of equivalents) at least Claim 22 of the '804 Patent.

59. Analog has infringed the '804 Patent by using the accused products and thereby practicing a method including defining a common time reference for a plurality of device adapters, said common time reference including a time frame having a plurality of time phases, each of said device adapters capable of being uniquely assigned to at least one of said time phases, said time phases including a free-access phase. For example, the accused products are used by Analog to implement the IEEE 802.1Q standard. IEEE standard 802.1Q implements a method in which a time aware bridged LAN transmits data from one end point i.e., Precision Time Protocol ("PTP") instance to another. The endpoints transmit data that is a mix of time-critical traffic and other traffic, (i.e., real time data and non-real time data) via PTP instances such as bridges (device adapters). The time aware bridged LAN use 802.1AS base time to maintain synchronized time (common time reference) for all the ports in the bridges (device adapters). The bridges containing ports schedule the transmission of traffic based on the synchronized time. Each port associated with a specific set of transmission queues includes a plurality of transmission gates. A transmission gate can be in a closed state or open state. The functionality of assigned time phases is achieved using open gates transmitting data packets during transmission time. The functionality of free access phase is achieved when the gates are opened for transmission during any time. IEEE Std. 802.1AS™ is normative and essential to implement an IEEE Std. 802.1Q Compliant System.

1.1 Project Number: P802.1Qbv
1.2 Type of Document: Standard
1.3 Life Cycle: Full Use

2.1 Title: Standard for Local and metropolitan area networks--Media Access Control (MAC) Bridges and Virtual Bridged Local Area Networks Amendment: Enhancements for Scheduled Traffic

5.2.b. Scope of the project: This amendment specifies time-aware queue-draining procedures, managed objects and extensions to existing protocols that enable bridges and end stations to schedule the transmission of frames based on a synchronized time. Virtual Local Area Network (VLAN) tag encoded priority values are allocated allowing simultaneous support of scheduled traffic, credit-based shaper traffic and other bridged traffic over Local Area Networks (LANs).

(Source: <http://www.ieee802.org/1/files/public/docs2014/bv-p802-1Qbv-par-modification-1114.pdf>)

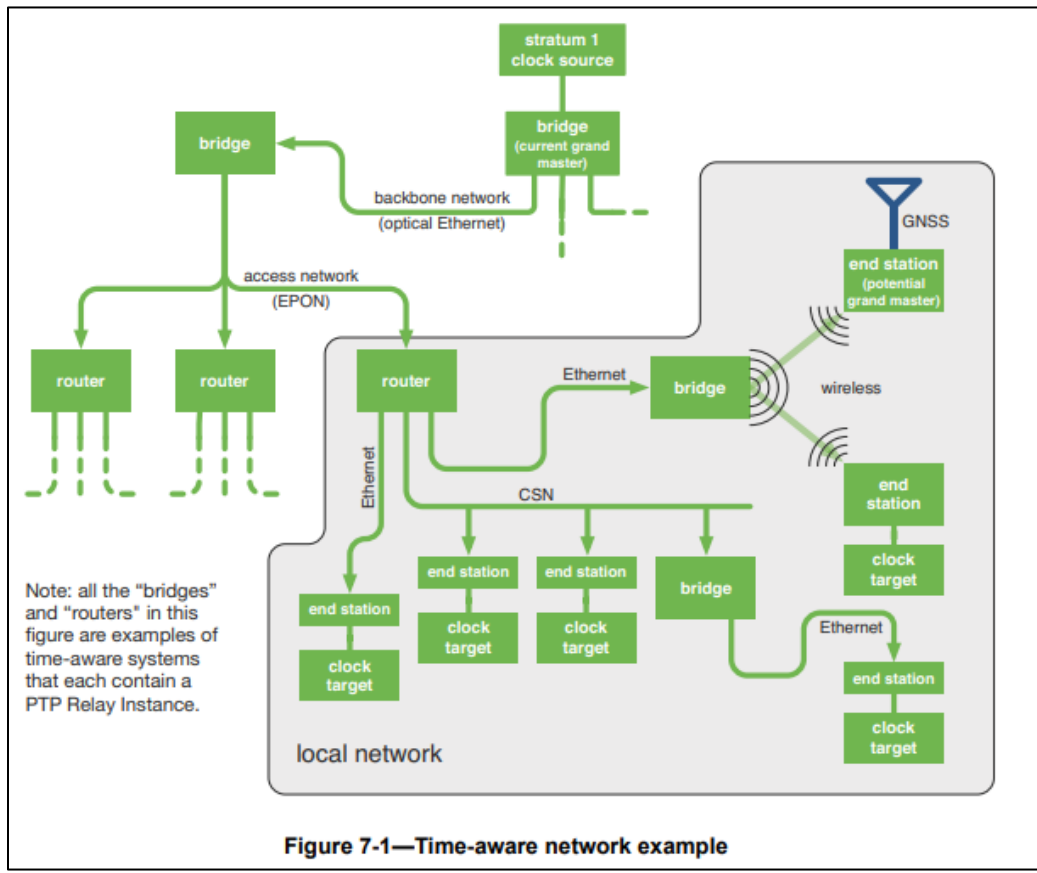

(Source: <https://1.ieee802.org/wp-content/uploads/2019/03/802-1AS-rev-d8-0.pdf>)

7.2 Architecture of a time-aware network

7.2.1 General

A time-aware network consists of a number of interconnected time-aware systems that support the gPTP defined within this standard. These time-aware systems can be any networking device, including, for example, bridges, routers, and end stations. A set of time-aware systems that are interconnected by gPTP-capable network elements is called a gPTP network. Each instance of gPTP that the time-aware systems support is in one gPTP domain, and the instances of gPTP are said to be part of that gPTP domain. A time-aware system can support, and therefore be part of, more than one gPTP domain. The entity of a single time-aware system that executes gPTP in one gPTP domain is called a PTP Instance. A time-aware system can contain multiple PTP Instances, which are each associated with a different gPTP domain. There are two

(Source: <https://1.ieee802.org/wp-content/uploads/2019/03/802-1AS-rev-d8-0.pdf>)

- c) In gPTP there are only two types of PTP Instances: PTP End Instances and PTP Relay Instances, while IEEE 1588 has ordinary clocks, boundary clocks, end-to-end transparent clocks, and P2P transparent clocks. A PTP End Instance corresponds to an IEEE 1588 ordinary clock, and a PTP Relay Instance is a type of IEEE 1588 boundary clock where its operation is very tightly defined, so much so that a PTP Relay Instance with Ethernet ports can be shown to be mathematically equivalent to a P2P transparent clock in terms of how synchronization is performed, as shown in

(Source: <https://1.ieee802.org/wp-content/uploads/2019/03/802-1AS-rev-d8-0.pdf>)

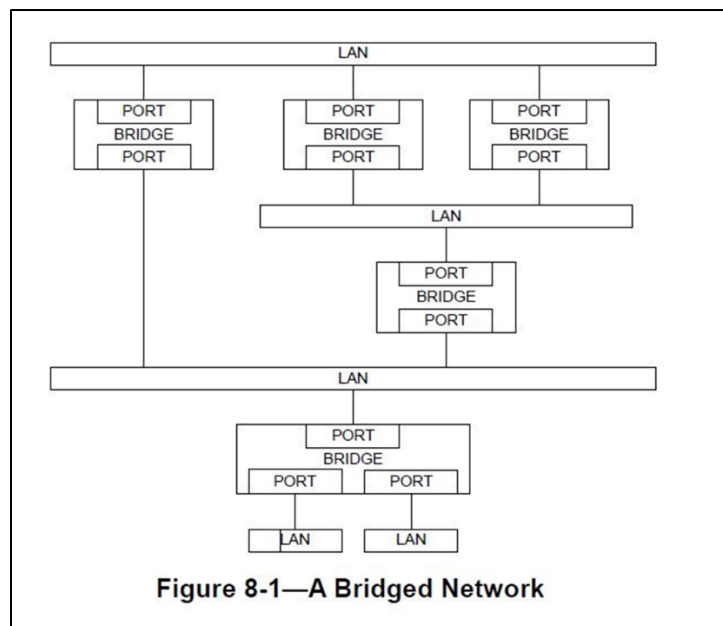

(Source: IEEE Standard for Local and Metropolitan Area Networks—Bridges and Bridged Networks- IEEE Std 802.1Q™-2018)

Traffic scheduling

This annex provides some background to the mechanisms provided in this standard for traffic scheduling, with the intent of providing some insight into the motivation for the provision of mechanisms for traffic scheduling and some of the ways that the mechanisms might be used.

Q.1 Motivation

Some applications have a need for frame delivery that is highly predictable in terms of the time at which frame transmission will occur, and the overall latency and jitter that will be experienced as the frame is propagated to its destination. Examples include industrial and automotive control applications, where data transmitted over the network is used to feed the parameters of control loops that are critical to the operation of the plant or machinery involved, and where frames carrying control data are transmitted on a repeating time schedule; late delivery of such frames can result in instability, inaccuracy, or failure of the operation of the control loops concerned. In some implementations, this need has been met by the provision of dedicated, highly engineered networks that are used solely for the transmission of time-critical control traffic; however, as the bandwidth occupied by such traffic is often low, and the cost of providing a dedicated control network can be high, it can be desirable to mix time-critical traffic with other classes of traffic in the same network, as long as such mixing can be achieved while still meeting the timing requirements of the time-critical traffic.

(Source: IEEE Standard for Local and metropolitan area networks— Bridges and Bridged Networks Amendment 25: Enhancements for Scheduled Traffic (IEEE 802.1Qbv-2015))

IEEE Std 802.1Q-2018 IEEE Standard for Local and Metropolitan Area Networks—Bridges and Bridged Networks
<h2><u>2. Normative references</u></h2> <p>The following referenced documents are indispensable for the application of this document (i.e., they must be understood and used, so each referenced document is cited in the text and its relationship to this document is explained). For dated references, only the edition cited applies. For undated references, the latest edition of the referenced document (including any amendments or corrigenda) applies.</p> <p>ANSI X3.159, American National Standards for Information Systems—Programming Language—C.⁵</p> <p>IEEE Std 802[®], IEEE Standard for Local and metropolitan area networks: Overview and Architecture.^{6,7}</p> <p>IEEE Std 802.1AB[™], IEEE Standard for Local and metropolitan area networks—Station and Media Access Control Connectivity Discovery.</p> <p>IEEE Std 802.1AC[™], IEEE Standard for Local and metropolitan area networks—Media Access Control (MAC) Service Definition.</p> <p>IEEE Std 802.1AE[™], IEEE Standard for Local and metropolitan area networks—Media Access Control (MAC) Security.</p> <p><u>IEEE Std 802.1AS[™], IEEE Standard for Local and metropolitan area networks—Timing and Synchronization for Time-Sensitive Applications in Bridged Local Area Networks.</u></p>

(Source: IEEE Standard for Local and Metropolitan Area Networks—Bridges and Bridged Networks- IEEE Std 802.1Q™-2018)

3.16 PTP End Instance: A PTP Instance that is capable of acting as the source of synchronized time on the network, or destination of synchronized time using the IEEE 802.1AS protocol, or both.

3.17 PTP Instance: A PTP Relay Instance or a PTP End Instance. A PTP Instance implements those portions of this standard indicated as applicable to a PTP Relay Instance or a PTP End Instance. Each PTP Instance operates in exactly one domain.

3.18 PTP Link: Within a domain, a network segment between two PTP Ports using the peer-to-peer delay mechanism of this standard. The peer-to-peer delay mechanism is designed to measure the propagation time over such a link.

NOTE—A PTP Link between PTP Ports of PTP Instances is also a gPTP Communication Path (see 3.9).

3.19 PTP Relay Instance: A PTP Instance that is capable of communicating synchronized time received on one port to other ports, using the IEEE 802.1AS protocol.

NOTE—A PTP Relay Instance could, for example, be contained in a bridge, a router, or a multi-port end station.

(Source: <https://1.ieee802.org/wp-content/uploads/2019/03/802-1AS-rev-d8-0.pdf>)

8.6.8.4 Enhancements for scheduled traffic

A Bridge or an end station may support enhancements that allow transmission from each queue to be scheduled relative to a known timescale. In order to achieve this, a transmission gate is associated with each queue; the state of the transmission gate determines whether or not queued frames can be selected for transmission (see Figure 8-12). For a given queue, the transmission gate can be in one of two states:

- a) Open: Queued frames are selected for transmission, in accordance with the definition of the transmission selection algorithm associated with the queue.
- b) Closed: Queued frames are not selected for transmission.

(Source: IEEE Standard for Local and metropolitan area networks— Bridges and Bridged Networks Amendment 25: Enhancements for Scheduled Traffic (IEEE 802.1Qbv-2015))

8.6.8 Transmission selection

For each Port, frames are selected for transmission on the basis of the traffic classes that the Port supports and the operation of the transmission selection algorithms supported by the corresponding queues on that Port. For a given Port and traffic class, frames are selected from the corresponding queue for transmission if and only if

- a) The operation of the transmission selection algorithm supported by that queue determines that there is a frame available for transmission; and
- b) For each queue corresponding to a numerically higher value of traffic class supported by the Port, the operation of the transmission selection algorithm supported by that queue determines that there is no frame available for transmission.

(Source: IEEE Standard for Local and Metropolitan Area Networks—Bridges and Bridged Networks- IEEE Std 802.1Q™-2018)

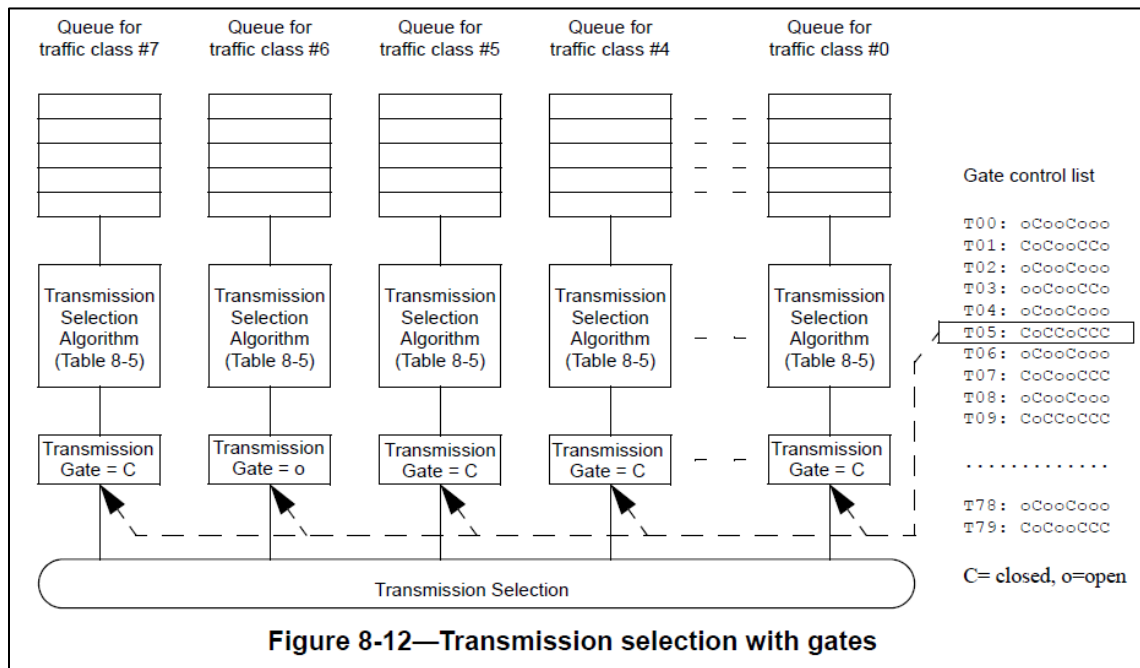

(Source: IEEE Standard for Local and metropolitan area networks— Bridges and Bridged Networks Amendment 25: Enhancements for Scheduled Traffic (IEEE 802.1Qbv-2015))

A gate control list associated with each Port contains an ordered list of gate operations. Each gate operation changes the transmission gate state for the gate associated with each of the Port’s traffic class queues. In an implementation that does not support enhancements for scheduled traffic, all gates are assumed to be permanently in the open state. Table 8-6 identifies the gate operation types, their parameters, and the actions that result from their execution. The state machines that control the execution of the gate control list, along with their variables and procedures, are specified in 8.6.9.

(Source: IEEE Standard for Local and metropolitan area networks— Bridges and Bridged Networks Amendment 25: Enhancements for Scheduled Traffic (IEEE 802.1Qbv-2015))

60. The methods practiced by Analog's use of the accused products include allowing a specified device adapter to transmit packets during time phase uniquely assigned to the specified device adapter and during said free-access phase. For example, the accused products are used by Analog to implement the IEEE 802.1Q standard. The open gates assigned to the transmission queue of a port (device adapter) transmit the data packets during the transmission time. The transmission selection algorithm determines the transmission time. If the gates are in permanent open state, the data packets are transmitted from the gates during any time. The functionality of assigned time phases is achieved using open gates transmitting data packets during transmission time. The functionality of free access phase is achieved when the gates are permanently opened for transmission during any time.

8.6.8.4 Enhancements for scheduled traffic

A Bridge or an end station may support enhancements that allow transmission from each queue to be scheduled relative to a known timescale. In order to achieve this, a transmission gate is associated with each queue; the state of the transmission gate determines whether or not queued frames can be selected for transmission (see Figure 8-12). For a given queue, the transmission gate can be in one of two states:

- a) Open: Queued frames are selected for transmission, in accordance with the definition of the transmission selection algorithm associated with the queue.
- b) Closed: Queued frames are not selected for transmission.

(Source: IEEE Standard for Local and metropolitan area networks— Bridges and Bridged Networks Amendment 25: Enhancements for Scheduled Traffic (IEEE 802.1Qbv-2015))

3.4 transmission gate: A gate that connects or disconnects the transmission selection function of the forwarding process from the queue, allowing or preventing it from selecting frames from that queue. The gate has two states, Open and Closed.

(Source: IEEE Standard for Local and metropolitan area networks— Bridges and Bridged Networks Amendment 25: Enhancements for Scheduled Traffic (IEEE 802.1Qbv-2015))

A gate control list associated with each Port contains an ordered list of gate operations. Each gate operation changes the transmission gate state for the gate associated with each of the Port's traffic class queues. In an implementation that does not support enhancements for scheduled traffic, all gates are assumed to be permanently in the open state. Table 8-6 identifies the gate operation types, their parameters, and the actions that result from their execution. The state machines that control the execution of the gate control list, along with their variables and procedures, are specified in 8.6.9.

(Source: IEEE Standard for Local and metropolitan area networks— Bridges and Bridged Networks Amendment 25: Enhancements for Scheduled Traffic (IEEE 802.1Qbv-2015))

61. The methods practiced by Analog's use of the accused products include designating one of said device adapters as a master timing device. For example, the accused products are used by Analog to implement the IEEE 802.1Q standard. IEEE standard 802.1Q implements a method in which a time aware bridged LAN transmits data from one Precision Time Protocol (PTP) instance (device adapter) to another. The ports of the time aware bridge use best master clock algorithm (BMCA) to determine a potential grandmaster port (master timing device).

7.2.2 Time-aware network consisting of a single gPTP domain

Figure 7-1 illustrates an example time-aware network consisting of a single gPTP domain, using all the above network technologies (i.e., (c) - (f) of 7.2.1), where end stations on several local networks are connected to a grandmaster on a backbone network via an EPON access network.

Any PTP Instance with clock sourcing capabilities can be a potential grandmaster, so there is a selection method (the best master clock algorithm, or BMCA) that ensures that all of the PTP Instances in a gPTP domain use the same grandmaster.¹² The BMCA is largely identical to that used in IEEE Std 1588-2019,

(Source: <https://1.ieee802.org/wp-content/uploads/2019/03/802-1AS-rev-d8-0.pdf>)

10.3.1.1 Best master clock algorithm overview

In the BMCA (i.e., method (a) of 10.3.1), best master selection information is exchanged between PTP Instances of time-aware systems via Announce messages (see 10.5 and 10.6). Each Announce message contains time-synchronization spanning tree vector information that identifies one PTP Instance as the root of the time-synchronization spanning tree and, if the PTP Instance is grandmaster-capable, the grandmaster. Each PTP Instance in turn uses the information contained in the Announce messages it receives, along with its knowledge of itself, to compute which of the PTP Instances that it has knowledge of ought to be the root of the spanning tree and, if grandmaster-capable, the grandmaster. As part of constructing the time-synchronization spanning tree, each port of each PTP Instance is assigned a port state from Table 10-2 by state machines associated with the ports and with the PTP Instance as a whole.

(Source: <https://1.ieee802.org/wp-content/uploads/2019/03/802-1AS-rev-d8-0.pdf>)

11.1.3 Transport of time-synchronization information

The transport of time-synchronization information by a PTP Instance, using Sync and Follow_Up (or just Sync) messages, is illustrated in Figure 11-2. The mechanism is mathematically equivalent to the mechanism described in IEEE Std 1588-2019 for a peer-to-peer transparent clock that is synchronized (see 11.4.5.1, 11.5.1, and 11.5.2.2 of IEEE Std 1588-2019). However, as will be seen shortly, the processes of transporting synchronization by a peer-to-peer transparent clock that is synchronized and by a boundary clock are mathematically and functionally equivalent. The main functional difference between the two types of clocks is that the boundary clock participates in best master selection and invokes the BMCA, while the peer-to-peer transparent clock does not participate in best master selection and does not invoke the BMCA (and implementations of the two types of clocks can be different).

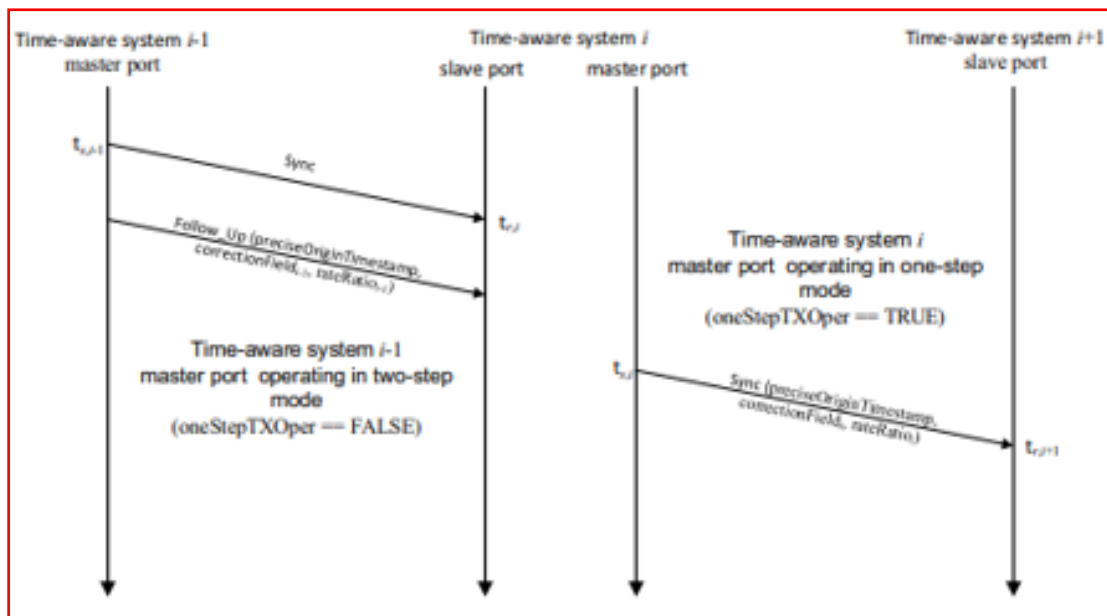

Figure 11-2—Transport of time-synchronization information

(Source: <https://1.ieee802.org/wp-content/uploads/2019/03/802-1AS-rev-d8-0.pdf>)

- c) In gPTP there are only two types of PTP Instances: PTP End Instances and PTP Relay Instances, while IEEE 1588 has ordinary clocks, boundary clocks, end-to-end transparent clocks, and P2P transparent clocks. A PTP End Instance corresponds to an IEEE 1588 ordinary clock, and a PTP Relay Instance is a type of IEEE 1588 boundary clock where its operation is very tightly defined, so much so that a PTP Relay Instance with Ethernet ports can be shown to be mathematically equivalent to a P2P transparent clock in terms of how synchronization is performed, as shown in

(Source: <https://1.ieee802.org/wp-content/uploads/2019/03/802-1AS-rev-d8-0.pdf>)

62. The methods practiced by Analog's use of the accused products include synchronizing the remaining device adapters with the designated master timing device. For example, the accused products are used by Analog to implement the IEEE 802.1Q standard. The boundary clocks of the slave ports in the time aware bridges (remaining device adapters) are synchronized with the grandmaster boundary clock (master timing device).

c) In gPTP there are only two types of PTP Instances: PTP End Instances and PTP Relay Instances, while IEEE 1588 has ordinary clocks, boundary clocks, end-to-end transparent clocks, and P2P transparent clocks. A PTP End Instance corresponds to an IEEE 1588 ordinary clock, and a PTP Relay Instance is a type of IEEE 1588 boundary clock where its operation is very tightly defined, so much so that a PTP Relay Instance with Ethernet ports can be shown to be mathematically equivalent to a P2P transparent clock in terms of how synchronization is performed, as shown in

(Source: <https://1.ieee802.org/wp-content/uploads/2019/03/802-1AS-rev-d8-0.pdf>)

3.16 PTP End Instance: A PTP Instance that is capable of acting as the source of synchronized time on the network, or destination of synchronized time using the IEEE 802.1AS protocol, or both.

3.17 PTP Instance: A PTP Relay Instance or a PTP End Instance. A PTP Instance implements those portions of this standard indicated as applicable to a PTP Relay Instance or a PTP End Instance. Each PTP Instance operates in exactly one domain.

3.18 PTP Link: Within a domain, a network segment between two PTP Ports using the peer-to-peer delay mechanism of this standard. The peer-to-peer delay mechanism is designed to measure the propagation time over such a link.

NOTE—A PTP Link between PTP Ports of PTP Instances is also a gPTP Communication Path (see 3.9).

3.19 PTP Relay Instance: A PTP Instance that is capable of communicating synchronized time received on one port to other ports, using the IEEE 802.1AS protocol.

NOTE—A PTP Relay Instance could, for example, be contained in a bridge, a router, or a multi-port end station.

(Source: <https://1.ieee802.org/wp-content/uploads/2019/03/802-1AS-rev-d8-0.pdf>)

11.1.3 Transport of time-synchronization information

The transport of time-synchronization information by a PTP Instance, using Sync and Follow_Up (or just Sync) messages, is illustrated in Figure 11-2. The mechanism is mathematically equivalent to the mechanism described in IEEE Std 1588-2019 for a peer-to-peer transparent clock that is synchronized (see 11.4.5.1, 11.5.1, and 11.5.2.2 of IEEE Std 1588-2019). However, as will be seen shortly, the processes of transporting synchronization by a peer-to-peer transparent clock that is synchronized and by a boundary clock are mathematically and functionally equivalent. The main functional difference between the two types of clocks is that the boundary clock participates in best master selection and invokes the BMCA, while the peer-to-peer transparent clock does not participate in best master selection and does not invoke the BMCA (and implementations of the two types of clocks can be different).

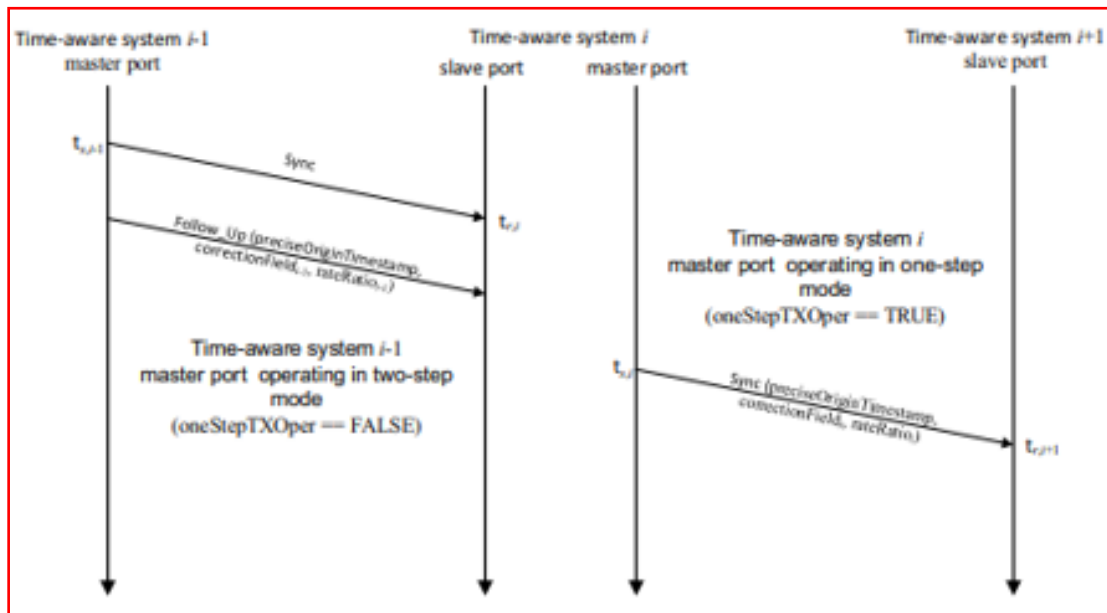

Figure 11-2—Transport of time-synchronization information

(Source: <https://1.ieee802.org/wp-content/uploads/2019/03/802-1AS-rev-d8-0.pdf>)

63. Far North Patents has been damaged as a result of the infringing conduct by Analog alleged above. Thus, Analog is liable to Far North Patents in an amount that adequately compensates it for such infringements, which, by law, cannot be less than a reasonable royalty, together with interest and costs as fixed by this Court under 35 U.S.C. § 284.

64. Far North Patents and/or its predecessors-in-interest have satisfied all statutory obligations required to collect pre-filing damages for the full period allowed by law for infringement of the '804 Patent.

ADDITIONAL ALLEGATIONS REGARDING INFRINGEMENT

65. Analog has also indirectly infringed the '053 Patent, the '702 Patent, the '797 Patent, the '504 Patent, and the '804 Patent by inducing others to directly infringe the '053 Patent, the '702 Patent, the '797 Patent, the '504 Patent, and the '804 Patent. Analog has induced the end-users, Analog's customers, to directly infringe (literally and/or under the doctrine of equivalents) the '053 Patent, the '702 Patent, the '797 Patent, the '504 Patent, and the '804 Patent by using the accused products.

66. Analog took active steps, directly and/or through contractual relationships with others, with the specific intent to cause them to use the accused products in a manner that infringes one or more claims of the patents-in-suit, including, for example, Claims 1 and 14 of the '053 Patent, Claim 27 of the '702 Patent, Claim 30 of the '797 Patent, Claims 1 and 6 of the '504 Patent, and Claim 22 of the '804 Patent.

67. Such steps by Analog included, among other things, advising or directing customers and end-users to use the accused products in an infringing manner; advertising and promoting the use of the accused products in an infringing manner; and/or distributing instructions that guide users to use the accused products in an infringing manner.

68. Analog has performed these steps, which constitute induced infringement, with the knowledge of the '053 Patent, the '702 Patent, the '797 Patent, the '504 Patent, and the '804 Patent and with the knowledge that the induced acts constitute infringement.

69. Analog was and is aware that the normal and customary use of the accused products by Analog's customers would infringe the '053 Patent, the '702 Patent, the '797 Patent, the '504 Patent, and the '804 Patent. Analog's inducement is ongoing.

70. Analog has also induced its affiliates, or third-party manufacturers, shippers, distributors, retailers, or other persons acting on its or its affiliates' behalf, to directly infringe (literally and/or under the doctrine of equivalents) the '053 Patent, the '702 Patent, the '797 Patent, the '504 Patent, and the '804 Patent by importing, selling or offering to sell the accused products.

71. Analog has at least a significant role in placing the accused products in the stream of commerce in Texas and elsewhere in the United States.

72. Analog directs or controls the making of accused products and their shipment to the United States, using established distribution channels, for sale in Texas and elsewhere within the United States.

73. Analog directs or controls the sale of the accused products into established United States distribution channels, including sales to nationwide retailers.

74. Analog's established United States distribution channels include one or more United States based affiliates.

75. Analog directs or controls the sale of the accused products in nationwide retailers and distributors such as Arrow Electronics, Digi-Key, and Mouser Electronics, including for sale in Texas and elsewhere in the United States, and expects and intends that the accused products will be so sold.

76. Analog took active steps, directly and/or through contractual relationships with others, with the specific intent to cause such persons to import, sell, or offer to sell the accused

products in a manner that infringes one or more claims of the patents-in-suit, including, for example, Claims 1 and 14 of the '053 Patent, Claim 27 of the '702 Patent, Claim 30 of the '797 Patent, Claims 1 and 6 of the '504 Patent, and Claim 22 of the '804 Patent.

77. Such steps by Analog included, among other things, making or selling the accused products outside of the United States for importation into or sale in the United States, or knowing that such importation or sale would occur; and directing, facilitating, or influencing its affiliates, or third-party manufacturers, shippers, distributors, retailers, or other persons acting on its or their behalf, to import, sell, or offer to sell the accused products in an infringing manner.

78. Analog performed these steps, which constitute induced infringement, with the knowledge of the '053 Patent, the '702 Patent, the '797 Patent, the '504 Patent, and the '804 Patent and with the knowledge that the induced acts would constitute infringement.

79. Analog performed such steps in order to profit from the eventual sale of the accused products in the United States.

80. Analog's inducement is ongoing.

81. Analog has also indirectly infringed by contributing to the infringement of the '053 Patent, the '702 Patent, the '797 Patent, the '504 Patent, and the '804 Patent. Analog has contributed to the direct infringement of the '053 Patent, the '702 Patent, the '797 Patent, the '504 Patent, and the '804 Patent by the end-user of the accused products.

82. The accused products have special features that are specially designed to be used in an infringing way and that have no substantial uses other than ones that infringe the '053 Patent, the '702 Patent, the '797 Patent, the '504 Patent, and the '804 Patent, including, for example, Claims 1 and 14 of the '053 Patent, Claim 27 of the '702 Patent, Claim 30 of the '797 Patent, Claims 1 and 6 of the '504 Patent, and Claim 22 of the '804 Patent.

83. The special features include advanced quality of service capabilities, used in a manner that infringes the '053 Patent, the '702 Patent, the '797 Patent, the '504 Patent, and the '804 Patent.

84. The special features constitute a material part of the invention of one or more of the claims of the '053 Patent, the '702 Patent, the '797 Patent, the '504 Patent, and the '804 Patent and are not staple articles of commerce suitable for substantial non-infringing use.

85. Analog's contributory infringement is ongoing.

86. Furthermore, Analog has a policy or practice of not reviewing the patents of others (including instructing its employees to not review the patents of others), and thus has been willfully blind of Far North Patents' patent rights. *See, e.g.*, M. Lemley, "Ignoring Patents," 2008 Mich. St. L. Rev. 19 (2008).

87. Analog's actions are at least objectively reckless as to the risk of infringing valid patents and this objective risk was either known or should have been known by Analog.

88. Analog has knowledge (at least constructively through its willful blindness) of the '053 Patent, the '702 Patent, the '797 Patent, the '504 Patent, and the '804 Patent.

89. Analog's customers have infringed the '053 Patent, the '702 Patent, the '797 Patent, the '504 Patent, and the '804 Patent.

90. Analog encouraged its customers' infringement.

91. Analog's direct and indirect infringement of the '053 Patent, the '702 Patent, the '797 Patent, the '504 Patent, and the '804 Patent is, has been, and/or continues to be willful, intentional, deliberate, and/or in conscious disregard of Far North Patents' rights under the patents.

92. Far North Patents has been damaged as a result of the infringing conduct by Analog alleged above. Thus, Analog is liable to Far North Patents in an amount that adequately compensates it for such infringements, which, by law, cannot be less than a reasonable royalty, together with interest and costs as fixed by this Court under 35 U.S.C. § 284.

JURY DEMAND

Far North Patents hereby requests a trial by jury on all issues so triable by right.

PRAYER FOR RELIEF

Far North Patents requests that the Court find in its favor and against Analog, and that the Court grant Far North Patents the following relief:

- a. Judgment that one or more claims of the '053 Patent, the '702 Patent, the '797 Patent, the '504 Patent, and the '804 Patent have been infringed, either literally and/or under the doctrine of equivalents, by Analog and/or all others acting in concert therewith;
- b. A permanent injunction enjoining Analog and its officers, directors, agents, servants, affiliates, employees, divisions, branches, subsidiaries, parents, and all others acting in concert therewith from infringement of the '053 Patent; or, in the alternative, an award of a reasonable ongoing royalty for future infringement of the '053 Patent by such entities;
- c. Judgment that Analog account for and pay to Far North Patents all damages to and costs incurred by Far North Patents because of Analog's infringing activities and other conduct complained of herein, including an award of all increased damages to which Far North Patents is entitled under 35 U.S.C. § 284;
- d. That Far North Patents be granted pre-judgment and post-judgment interest on the damages caused by Analog's infringing activities and other conduct complained of herein;
- e. That this Court declare this an exceptional case and award Far North Patents its

reasonable attorney's fees and costs in accordance with 35 U.S.C. § 285; and

f. That Far North Patents be granted such other and further relief as the Court may deem just and proper under the circumstances.

Dated: March 25, 2020

Respectfully submitted,

/s/ Zachariah S. Harrington

Matthew J. Antonelli

Texas Bar No. 24068432

matt@ahtlawfirm.com

Zachariah S. Harrington

Texas Bar No. 24057886

zac@ahtlawfirm.com

Larry D. Thompson, Jr.

Texas Bar No. 24051428

larry@ahtlawfirm.com

Christopher Ryan Pinckney

Texas Bar No. 24067819

ryan@ahtlawfirm.com

ANTONELLI, HARRINGTON

& THOMPSON LLP

4306 Yoakum Blvd., Ste. 450

Houston, TX 77006

(713) 581-3000

Attorneys for Far North Patents, LLC