

**IN THE UNITED STATES DISTRICT COURT  
FOR THE WESTERN DISTRICT OF TEXAS  
WACO DIVISION**

WSOU INVESTMENTS, LLC d/b/a  
BRAZOS LICENSING AND  
DEVELOPMENT,

Plaintiff,

v.

ZTE CORPORATION, ZTE (USA)  
INC., AND ZTE (TX), INC.

Defendants.

§  
§  
§  
§  
§  
§  
§  
§  
§  
§  
§  
§

CIVIL ACTION NO. 6:20-cv-238

**JURY TRIAL DEMANDED**

**ORIGINAL COMPLAINT FOR PATENT  
INFRINGEMENT**

Plaintiff WSOU Investments, LLC d/b/a Brazos Licensing and Development (“Brazos” or “Plaintiff”), by and through its attorneys, files this Complaint for Patent Infringement against Defendants ZTE Corporation, ZTE (USA), Inc. and ZTE (TX), Inc. (collectively “ZTE” or “Defendants”) and alleges:

**NATURE OF THE ACTION**

1. This is a civil action for patent infringement arising under the Patent Laws of the United States, 35 U.S.C. §§ 1, et seq., including §§ 271, 281, 284, and 285.

**THE PARTIES**

2. Brazos is a limited liability corporation organized and existing under the laws of Delaware, with its principal place of business at 605 Austin Ave, Ste 6, Waco, TX 76701.

3. On information and belief, Defendant Zhongxing Telecommunications Equipment (abbreviated as “ZTE”) Corporation is a Chinese corporation that does business in Texas, directly or through intermediaries, with a principal place of business at ZTE Plaza, Keji Road South, Hi-Tech Industrial Park, Nanshan District, Shenzhen China.

4. On information and belief, Defendant ZTE (USA) Inc. is a New Jersey corporation that does business in Texas, directly or through intermediaries, with a principal place of business in business in Richardson, Texas.

5. On information and belief, Defendant ZTE (TX) Inc. is a Texas corporation that does business in Texas, directly or through intermediaries, with a principal place of business in business in Austin, Texas.

6. All of the Defendants operate under and identify with the trade name “ZTE.” Each of the Defendants may be referred to individually as a “ZTE Defendant” and, collectively, Defendants may be referred to below as “ZTE” or as the “ZTE Defendants.”

#### **JURISDICTION AND VENUE**

7. This is an action for patent infringement which arises under the Patent Laws of the United States, in particular, 35 U.S.C. §§271, 281, 284, and 285.

8. This Court has jurisdiction over the subject matter of this action under 28 U.S.C. §§ 1331 and 1338(a).

9. This Court has specific and general personal jurisdiction over each ZTE Defendant pursuant to due process and/or the Texas Long Arm Statute, because each ZTE Defendant has committed acts giving rise to this action within Texas and within this judicial district. The Court’s exercise of jurisdiction over each ZTE Defendant would not offend traditional notions of fair play and substantial justice because ZTE has established minimum contacts with the forum. For example, on information and belief, ZTE Defendants have committed acts of infringement in this judicial district, by among other things, selling and offering for sale products that infringe the asserted patent, directly or through intermediaries, as alleged herein.

10. Venue in the Western District of Texas is proper pursuant to 28 U.S.C. §§1391 and/or 1400(b). The ZTE Defendants have committed acts of infringement and have places of businesses in this District and/or are foreign entities for purpose of §1391. As non-limiting examples, ZTE (TX) has maintained a place of business at 7000 N MO-PAC EXPRESSWAY 200 AUSTIN, TX 7873; and, ZTE (USA) has maintained a place of business at 6500 River Place Blvd., Austin, TX 78730. ZTE Corporation also describes a “research-and-development center in Austin, Texas.”<sup>1</sup>

**COUNT ONE - INFRINGEMENT OF**  
**U.S. PATENT NO. 9,294,060**

11. Brazos re-alleges and incorporates by reference the preceding paragraphs of this Complaint.

12. On March 22, 2016, the United States Patent and Trademark Office duly and legally issued U.S. Patent No. 9,294,060 (“the ’060 Patent”), entitled “BANDWIDTH EXTENDER.” A true and correct copy of the ’060 Patent is attached as Exhibit A to this Complaint.

13. Brazos is the owner of all rights, title, and interest in and to the ’060 Patent, including the right to assert all causes of action arising under the ’060 Patent and the right to any remedies for the infringement of the ’060 Patent.

14. ZTE makes, uses, sells, offers for sale, imports, and/or distributes, in the United States, communication products including an Enhanced Voice Services (EVS) codec to provide HD voice+ or ultra HD audio (collectively, the “Accused Products”).

---

<sup>1</sup> [https://res-www.zte.com.cn/mediare/magazine/publication/tech\\_en/pdf/201009.pdf](https://res-www.zte.com.cn/mediare/magazine/publication/tech_en/pdf/201009.pdf)

15. EVS is a 3GPP conversational codec offering up to 20 kHz audio bandwidth, delivering speech quality that matches other audio input such as stored music, while offering high robustness to delay jitter and packet losses.

16. The Accused Products include Axon 10 Pro, Axon M, and Axon 7 phones and any ZTE products including the Qualcomm Snapdragon X12 LTE Modem, the Qualcomm Snapdragon X16 LTE Modem, the Qualcomm Snapdragon X20 LTE Modem, or the Qualcomm Snapdragon X24 LTE Modem (having the Qualcomm Snapdragon 855 Mobile Platform).

**Powerful Performance**

[Powerful flagship chip]: Qualcomm® Snapdragon™ 855 Mobile Platform  
 [F2FS File System]: Improves the speed of reading and writing to the memory  
 [A Professional Antenna Solution]: Optimized harmonic and intermodulation; Automatically adjustable antenna; Smart SAR solution  
 [New generation AI performance engine]: Benchmark; Acceleration; Smooth; Lag-free  
 [Quick Unlock by Face Recognition]: Raise to wake and unlock  
 [In-display Fingerprint]: 0.272s unlock, faster and more concise  
 [Fast Gaming Experience]: Enhanced image processing; Enhanced link; Cooling system  
 [Battery&Data Transfer]4000mAh, QC4+; USB TypeC 3.1 high speed transmission; Wireless Quick Charge

<https://www.zteusa.com/axon-10-pro.html>.

Chipset	Multi SIM	Next-generation Calling Services
Snapdragon X24 LTE Modem	LTE Dual SIM Dual Standby (DSDS)+LAA	VoLTE with SRVCC to 3G and 2G
Snapdragon 8cx Compute Platform	Dual SIM Dual VoLTE (DSDV)	HD and Ultra HD Voice (EVS)
Snapdragon 855 Mobile Platform		CSFB to 3G and 2G

<https://www.qualcomm.com/snapdragon/modems/comparison>.

The EVS codec supports operating points as shown in the following table:

Bandwidth	Bit Rate (kbps)
Narrowband (NB)	5.9, 7.2, 8, 9.6, 13.2, 16.4, 24.4
Wideband (WB)	5.9, 7.2, 8, 9.6, 13.2, 13.2 channel-aware, 16.4, 24.4, 32, 48, 64, 96, 128 (6.6 ~ 23.85 for AMR-WB IO)
Super-wideband (SWB)	9.6, 13.2, 13.2 channel-aware, 16.4, 24.4, 32, 48, 64, 96, 128
Fullband (FB)	16.4, 24.4, 32, 48, 64, 96, 128

[https://www.3gpp.org/news-events/1639-evs\\_news](https://www.3gpp.org/news-events/1639-evs_news).

17. In audio processing, e.g., audio coding, “excitation-based” models can generate speech. In the EVS codec, processing can include a multi-rate audio codec, a source controlled variable bit-rate (SC-VBR) scheme, a voice/sound activity detector (VAD), a comfort noise generation (CNG) system, and an error concealment (EC) mechanism to neutralize the detrimental effects of transmission errors resulting in lost packets.

#### 4.4 Coder overview

The EVS codec employs a hybrid coding scheme combining linear predictive (LP) coding techniques based upon ACELP (Algebraic Code Excited Linear Prediction), predominantly for speech signals, with a transform coding method, for generic content, as well as inactive signal coding in conjunction with VAD/DTX/CNG (Voice Activity Detection/Discontinuous Transmission/ Comfort Noise Generation) operation. The EVS codec is capable of switching between these different coding modes without artefacts.

The EVS codec supports 5.9kbps narrowband and wideband variable bit rate (VBR) operation based upon the ACELP coding paradigm which also provides the AMR-WB interoperable encoding and decoding. In addition to perceptually optimized waveform matching, the codec utilizes parametric representations of certain frequency ranges. These parametric representations constitute coded bandwidth extensions or noise filling strategies.

[https://www.etsi.org/deliver/etsi\\_ts/126400\\_126499/126445/15.02.00\\_60/ts\\_126445v150200p.pdf](https://www.etsi.org/deliver/etsi_ts/126400_126499/126445/15.02.00_60/ts_126445v150200p.pdf) (Page 21).

18. The signal resampling block within an EVS encoder corrects mismatches between the sampling frequency and the signal bandwidth command line parameter that is specified on the command line or through a file containing a bandwidth switching profile. The signal analysis determines which of three possible encoder strategies to employ: LP (Linear

Prediction) based coding (ACELP), frequency domain encoding and inactive coding/Comfort Noise Generator (CNG).

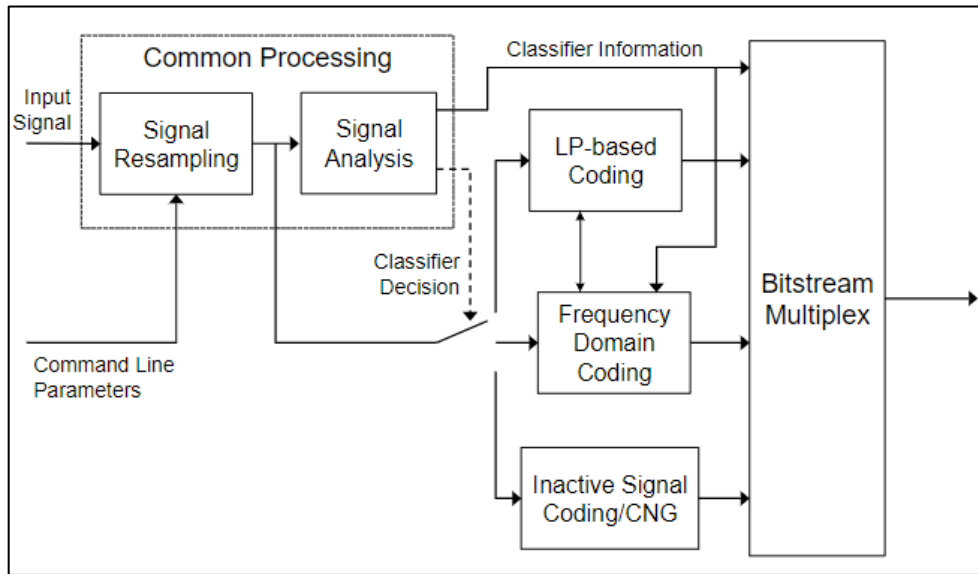

[https://www.etsi.org/deliver/etsi\\_ts/126400\\_126499/126445/15.02.00\\_60/ts\\_126445v150200p.pdf](https://www.etsi.org/deliver/etsi_ts/126400_126499/126445/15.02.00_60/ts_126445v150200p.pdf) (Page 22).

19. In the EVS Codec, the CNG algorithm reproduces high-quality comfort noise by choosing between a linear prediction-domain based coding mode (LP-CNG) and a frequency-domain based coding mode (FD-CNG), according to the input characteristics. In the FD-CNG mode, the Comfort Noise (CN) parameters consisting of global gain and spectral energies grouped in critical bands. In the LP-CNG mode, four CN parameters are analyzed and encoded: the low-band excitation energy, the low-band signal spectrum, the low-band excitation envelope,

and the high-band energy, where the high-band energy is only encoded for SWB/FB input.

### 5.6.1 Overview

This subclause describes the discontinuous transmission (DTX) scheme and the comfort noise generation (CNG) algorithm. The DTX/CNG operation, which is activated on a command line, is used to reduce the transmission rate by simulating background noise during inactive signal periods. The regular DTX/CNG modes are supported for bit rates up to 24.4 kbps. For higher bit rates, the EVS codec supports a less aggressive DTX/CNG scheme that only switches to CNG for low input signal power.

The reduction of the transmission rate during inactive periods is achieved by coding the parameters referred to as comfort noise (CN) parameters. These parameters are used at the decoder to regenerate the background noise as well as possible, by respecting the spectral and temporal content of the background noise at the encoder. In the EVS Codec, the CNG algorithm reproduces high quality comfort noise by choosing between a linear prediction-domain based coding mode (LP-CNG) and a frequency-domain based coding mode (FD-CNG), according to the input characteristics. Each of the two coding modes utilizes a different set of CN parameters. In the LP-CNG mode, four CN parameters are analyzed and encoded: the low-band excitation energy, the low-band signal spectrum, the low-band excitation envelope and the high-band energy, where the high-band energy is only encoded for SWB/FB input. In the FD-CNG mode, the CN parameters consisting of global gain and spectral energies grouped in critical bands. Those parameters are encoded by a vector quantizer for transmission.

[https://www.etsi.org/deliver/etsi\\_ts/126400\\_126499/126445/15.02.00\\_60/ts\\_126445v150200p.pdf](https://www.etsi.org/deliver/etsi_ts/126400_126499/126445/15.02.00_60/ts_126445v150200p.pdf) (Page 425).

20. The excitation energy in the current frame (i.e, audio signal) is computed for each inactive frame.

#### 5.6.2.1.5 LP-CNG energy calculation and quantization

The excitation energy in the current frame is computed for each inactive frame according to the following equation:

$$E_{log} = \log_2 \left( \frac{1}{L} \sum_{n=0}^{L-1} r^2(n) \right) \quad (1334)$$

where  $r(n)$  is the LP residual signal, calculated by filtering the pre-emphasized inactive input signal,  $s_{pre}(n)$ , through the filter  $\hat{A}(z)$ ,  $L=256$  or  $320$  depending on the sampling rate of the core. Then a weighted average energy is computed over the whole CN averaging period by

$$\bar{E}_{log} = \frac{\sum_{n=-N_{CN}+1}^0 w(n) E_{log}^{[n]}}{\sum_{n=-N_{CN}+1}^0 w(n)} - E_{offset} \quad (1335)$$

[https://www.etsi.org/deliver/etsi\\_ts/126400\\_126499/126445/15.02.00\\_60/ts\\_126445v150200p.pdf](https://www.etsi.org/deliver/etsi_ts/126400_126499/126445/15.02.00_60/ts_126445v150200p.pdf) (Page 432).

21. An audio signal can consist of active and inactive periods. When the codec is operated with the DTX (Discontinuous Transmission)/CNG operation, the signal activity detector (SAD) is used to analyze the audio input signal to determine whether the signal

comprises an active or inactive signal. The reduction of the transmission rate during inactive periods is achieved by coding the parameters referred to as comfort noise (CN) parameters. Thus at least the CN parameter has time components. DTX functions run at the encoder that transmits either a silence insertion descriptor (SID) frame or a NO\_DATA frame. The SID frame contains the comfort noise (CN) parameters, which are used to update the statistics of the background noise at the decoder.

22. The low-frequency spectral envelope of the LP residual is not quantized directly. Instead, an averaged spectral envelope is calculated over the CN averaging period. The spectral envelopes of the two outliers identified are removed from the averaging. To encode this averaged low-frequency spectral envelope, the spectral details of the averaged low-frequency spectral envelope is extracted and used for actual quantization.

#### 5.6.2.1.7 LP-CNG LF-BOOST determination and quantization

While the quantized LSF spectrum generally estimates well the spectrum of most background noises, it is found less sufficient for noises which have strong low frequency component for example the car noise. To compensate the missing low frequency component, the spectral envelope in the low frequency portion of the LP residual signal is quantized and transmitted in the SID frame. Note that this quantized residual spectral envelope is only transmitted in WB SID frame

The LP residual signal  $r(n)$  calculated in subclause 5.6.2.1.5 is first attenuated by multiplying an attenuation factor  $att$  for all input bandwidth except NB. The attenuation factor is calculated as

$$att = \frac{3}{3 + 4flr} \quad (1341)$$

where  $flr = 0.6$  if the bandwidth is not WB or the latest bitrate used for actively encoded frames  $R_{latest\_active}$  is larger than 16.4 kbps. Otherwise  $flr$  is determined from a hangover attenuation floor table as defined in table 35b. The attenuation factor  $att$  is finally lower limited to  $flr$ . Then a FFT is used to obtain the frequency representation of the LP residual signal and a spectral envelope which is the energies of the first 20 FFT bins in the low frequency portion of the frequency representation (excluding the DC bin) is calculated as

[https://www.etsi.org/deliver/etsi\\_ts/126400\\_126499/126445/15.02.00\\_60/ts\\_126445v150200p.pdf](https://www.etsi.org/deliver/etsi_ts/126400_126499/126445/15.02.00_60/ts_126445v150200p.pdf) (Page 433).

23. The distance vector  $D(k)$  is quantized by vector quantization. A codeword having a minimum prediction error is found by a direct search in the codebook and the index of the codeword is transmitted in the WB SID frame. The quantized low-frequency envelope is



recovered and used in the local CNG synthesis.

where  $N$  is the length of CN averaging period,  $E_{env,i}(k)$  denotes the low frequency envelope of the  $i$ -th frame in the CN averaging period,  $o1, o2$  denotes the index of the two outliers. To encode this averaged low frequency spectral envelope, the spectral details of the averaged low frequency spectral envelope is extracted and used for actual quantization. The spectral details,  $Env'_{avg}(k)$ , is obtained by subtracting an envelope floor which is equal to two times of the quantized average excitation energy from the averaged low frequency spectral envelope, that is

$$Env'_{avg}(k) = MAX \left[ Env_{avg}(k) - 2\hat{E}, 0 \right], \quad k = 0, \dots, 19 \quad (1344)$$

where  $Env'_{avg}(k)$  is bounded to non-negative value.  $Env'_{avg}(k)$  is then converted to log domain

$$Env'_{log}(k) = \log_2 Env'_{avg}(k), \quad k = 0, \dots, 19 \quad (1345)$$

where  $E_{offset}$  is the energy offset value calculated in subclause 5.6.2.1.5 and  $Env'_{log}(k)$  are bounded to non-negative value. A distance vector is calculated as

$$D(k) = \hat{E}_{exc} - Env'_{log}(k), \quad k = 0, \dots, 19 \quad (1346)$$

where  $\hat{E}_{exc}$  is the quantized total excitation energy calculated as

$$\hat{E}_{exc} = \log_2 \left( L_{exc} \cdot \hat{E} \right) \quad (1347)$$

where  $L_{exc} = 256$  is the length of the excitation. The distance vector  $D(k)$  is quantized by a vector quantization. The codeword having the minimum prediction error is found by a direct search in the codebook and the index of the codeword is transmitted in the WB SID frame. The quantized low frequency envelope is recovered and used in the local CNG synthesis.

[https://www.etsi.org/deliver/etsi\\_ts/126400\\_126499/126445/15.02.00\\_60/ts\\_126445v150200p.pdf](https://www.etsi.org/deliver/etsi_ts/126400_126499/126445/15.02.00_60/ts_126445v150200p.pdf) (Page 434).

The excitation representing the low frequency spectral details of the excitation signal is generated from the quantized residual spectral envelope. The quantized residual spectral envelope is recovered from each WB SID frame in the inverse way as described in subclause 5.6.2.1.6 that

$$E\hat{n}v(k) = 2^{\hat{E}_{exc} - D(k)}, \quad k = 0, \dots, 19 \quad (1957)$$

where  $E\hat{n}v(k)$  is the quantized residual spectral envelope,  $D(k)$  is the entry of the residual spectral envelope codebook found with the index decoded from the SID frame,  $\hat{E}_{exc}$  is the quantized total excitation energy calculated using the similar equation in subclause 5.6.2.1.6. A smoothed residual spectral envelope is updated at each CN frame by  $E\hat{n}v(k)$  through an AR filtering

$$Env_{CN}(k) = 0.9Env_{CN}^{[-1]}(k) + 0.1E\hat{n}v(k), \quad k = 0, \dots, 19 \quad (1958)$$

[https://www.etsi.org/deliver/etsi\\_ts/126400\\_126499/126445/15.02.00\\_60/ts\\_126445v150200p.pdf](https://www.etsi.org/deliver/etsi_ts/126400_126499/126445/15.02.00_60/ts_126445v150200p.pdf) (Page 597).

#### 6.9.1.2.2 CNA noise estimation in DTX-on mode when LP-CNG is triggered

To enable tracking of the noise spectrum when LP-CNG is triggered in DTX-on mode, the FD-CNG noise estimation algorithm (see clause 6.7.3.2.2) is applied at the output of the LP-CNG during inactive frames, yielding noise estimates  $N_{FD-CNG}^{[shaping]}(i)$  in each spectral partition  $i = 0, \dots, L_{shaping} - 1$ . Following the technique described in clause 6.7.3.2.3.1., the parameters  $N_{FD-CNG}^{[shaping]}(i)$  are then interpolated to yield the full-resolution FFT power spectrum  $N_{FD-CNG}^{[shaping,FR]}(j)$ , which overwrites the current FD-CNG levels, i.e.  $N_{FD-CNG}^{[CNG]}(j) = N_{FD-CNG}^{[shaping,FR]}(j)$ .

[https://www.etsi.org/deliver/etsi\\_ts/126400\\_126499/126445/15.02.00\\_60/ts\\_126445v150200p.pdf](https://www.etsi.org/deliver/etsi_ts/126400_126499/126445/15.02.00_60/ts_126445v150200p.pdf) (Page 628).

24. In the LP-CNG mode, excitation(s) and synthesis filter(s) are calculated from the decoded CN parameters, and the comfort noise is synthesized by an LP synthesis approach. The excitation representing the low-frequency spectral details of the excitation signal is generated from the quantized residual spectral envelope.

25. FFT is used to obtain the frequency representation of the LP residual signal and a spectral envelope which is the energies of the first 20 FFT bins in the low-frequency portion of the frequency representation. To compensate for the missing low-frequency component, the spectral envelope in the low-frequency portion of the LP residual signal is quantized and transmitted in the SID frame.

### 5.6.2.1.5 LP-CNG energy calculation and quantization

The excitation energy in the current frame is computed for each inactive frame according to the following equation:

$$E_{\log} = \log_2 \left( \frac{1}{L} \sum_{n=0}^{L-1} r^2(n) \right) \quad (1334)$$

where  $r(n)$  is the LP residual signal, calculated by filtering the pre-emphasized inactive input signal,  $s_{pre}(n)$ , through the filter  $\hat{A}(z)$ ,  $L=256$  or  $320$  depending on the sampling rate of the core. Then a weighted average energy is computed over the whole CN averaging period by

$$\bar{E}_{\log} = \frac{\sum_{n=-N_{CN}+1}^0 w(n) E_{\log}^{[n]}}{\sum_{n=-N_{CN}+1}^0 w(n)} - E_{offset} \quad (1335)$$

[https://www.etsi.org/deliver/etsi\\_ts/126400\\_126499/126445/15.02.00\\_60/ts\\_126445v150200p.pdf](https://www.etsi.org/deliver/etsi_ts/126400_126499/126445/15.02.00_60/ts_126445v150200p.pdf) (Page 432).

### 5.6.2.1.7 LP-CNG LF-BOOST determination and quantization

While the quantized LSF spectrum generally estimates well the spectrum of most background noises, it is found less sufficient for noises which have strong low frequency component for example the car noise. To compensate the missing low frequency component, the spectral envelope in the low frequency portion of the LP residual signal is quantized and transmitted in the SID frame. Note that this quantized residual spectral envelope is only transmitted in WB SID frame

The LP residual signal  $r(n)$  calculated in subclause 5.6.2.1.5 is first attenuated by multiplying an attenuation factor  $att$  for all input bandwidth except NB. The attenuation factor is calculated as

$$att = \frac{3}{3 + 4 \cdot flr} \quad (1341)$$

where  $flr = 0.6$  if the bandwidth is not WB or the latest bitrate used for actively encoded frames  $R_{latest\_active}$  is larger than 16.4 kbps. Otherwise  $flr$  is determined from a hangover attenuation floor table as defined in table 35b. The attenuation factor  $att$  is finally lower limited to  $flr$ . Then a FFT is used to obtain the frequency representation of the LP residual signal and a spectral envelope which is the energies of the first 20 FFT bins in the low frequency portion of the frequency representation (excluding the DC bin) is calculated as

[https://www.etsi.org/deliver/etsi\\_ts/126400\\_126499/126445/15.02.00\\_60/ts\\_126445v150200p.pdf](https://www.etsi.org/deliver/etsi_ts/126400_126499/126445/15.02.00_60/ts_126445v150200p.pdf) (Page 433).

where  $N$  is the length of CN averaging period,  $E_{env,i}(k)$  denotes the low frequency envelope of the  $i$ -th frame in the CN averaging period,  $o1, o2$  denotes the index of the two outliers. To encode this averaged low frequency spectral envelope, the spectral details of the averaged low frequency spectral envelope is extracted and used for actual quantization. The spectral details,  $Env'_{avg}(k)$ , is obtained by subtracting an envelope floor which is equal to two times of the quantized average excitation energy from the averaged low frequency spectral envelope, that is

$$Env'_{avg}(k) = MAX \left[ Env_{avg}(k) - 2\hat{E}, 0 \right], \quad k = 0, \dots, 19 \quad (1344)$$

where  $Env'_{avg}(k)$  is bounded to non-negative value.  $Env'_{avg}(k)$  is then converted to log domain

$$Env'_{log}(k) = \log_2 Env'_{avg}(k), \quad k = 0, \dots, 19 \quad (1345)$$

where  $E_{offset}$  is the energy offset value calculated in subclause 5.6.2.1.5 and  $Env'_{log}(k)$  are bounded to non-negative value. A distance vector is calculated as

$$D(k) = \hat{E}_{exc} - Env'_{log}(k), \quad k = 0, \dots, 19 \quad (1346)$$

where  $\hat{E}_{exc}$  is the quantized total excitation energy calculated as

$$\hat{E}_{exc} = \log_2 \left( L_{exc} \cdot \hat{E} \right) \quad (1347)$$

where  $L_{exc} = 256$  is the length of the excitation. The distance vector  $D(k)$  is quantized by a vector quantization. The codeword having the minimum prediction error is found by a direct search in the codebook and the index of the codeword is transmitted in the WB SID frame. The quantized low frequency envelope is recovered and used in the local CNG synthesis.

[https://www.etsi.org/deliver/etsi\\_ts/126400\\_126499/126445/15.02.00\\_60/ts\\_126445v150200p.pdf](https://www.etsi.org/deliver/etsi_ts/126400_126499/126445/15.02.00_60/ts_126445v150200p.pdf) (Page 434).

26. In view of preceding paragraphs, each and every element of at least claim 1 of the '060 Patent is found in the Accused Products.

27. ZTE has and continues to directly infringe at least one claim of the '060 Patent, literally or under the doctrine of equivalents, by making, using, selling, offering for sale, importing, and/or distributing the Accused Products in the United States, including within this judicial district, without the authority of Brazos.

28. ZTE has received notice and actual or constructive knowledge of the '060 Patent since at least the date of service of this Complaint.

29. Since at least the date of service of this Complaint, through its actions, ZTE has actively induced product makers, distributors, retailers, and/or end users of the Accused Products

to infringe the '060 Patent throughout the United States, including within this judicial district, by, among other things, advertising and promoting the use of the Accused Products in various websites, including providing and disseminating product descriptions, operating manuals, and other instructions on how to implement and configure the Accused Products. Examples of such advertising, promoting, and/or instructing include the documents at:

- <https://www.zteusa.com/axon-10-pro.html>

30. Since at least the date of service of this Complaint, through its actions, ZTE has contributed to the infringement of the '060 Patent by having others sell, offer for sale, or use the Accused Products throughout the United States, including within this judicial district, with knowledge that the Accused Products infringe the '060 Patent. The Accused Products are especially made or adapted for infringing the '060 Patent and have no substantial non-infringing use. For example, in view of the preceding paragraphs, the Accused Products contain functionality which is material to at least one claim of the '060 Patent.

#### **JURY DEMAND**

Brazos hereby demands a jury on all issues so triable.

#### **REQUEST FOR RELIEF**

WHEREFORE, Brazos respectfully requests that the Court:

(A) Enter judgment that ZTE infringes one or more claims of the '060 Patent literally and/or under the doctrine of equivalents;

(B) Enter judgment that ZTE has induced infringement and continues to induce infringement of one or more claims of the '060 Patent;

(C) Enter judgment that ZTE has contributed to and continues to contribute to the infringement of one or more claims of the '060 Patent;

(D) Award Brazos damages, to be paid by ZTE in an amount adequate to compensate Brazos for such damages, together with pre-judgment and post-judgment interest for the infringement by ZTE of the '060 Patent through the date such judgment is entered in accordance with 35 U.S.C. §284, and increase such award by up to three times the amount found or assessed in accordance with 35 U.S.C. §284;

(E) Declare this case exceptional pursuant to 35 U.S.C. §285; and

(F) Award Brazos its costs, disbursements, attorneys' fees, and such further and additional relief as is deemed appropriate by this Court.

Dated: March 27, 2020

Respectfully submitted,

/s/ James L. Etheridge

James L. Etheridge  
Texas State Bar No. 24059147  
Ryan S. Loveless  
Texas State Bar No. 24036997  
Travis L. Richins  
Texas State Bar No. 24061296  
ETHERIDGE LAW GROUP, PLLC  
2600 E. Southlake Blvd., Suite 120 / 324  
Southlake, Texas 76092  
Telephone: (817) 470-7249  
Facsimile: (817) 887-5950  
[Jim@EtheridgeLaw.com](mailto:Jim@EtheridgeLaw.com)  
[Ryan@EtheridgeLaw.com](mailto:Ryan@EtheridgeLaw.com)  
[Travis@EtheridgeLaw.com](mailto:Travis@EtheridgeLaw.com)

***COUNSEL FOR PLAINTIFF***