

1 Brandon J. Witkow (SBN 210443)
2 bw@witkowlaw.com
3 Cory A. Baskin (SBN 240517)
4 cb@witkowlaw.com
5 witkow | baskin
6 21031 Ventura Boulevard, Suite 700
7 Woodland Hills, California 91364
8 Tel: 818.296.9508
9 Fax: 818.296.9510

10 Attorneys for *Plaintiff*
11 2BCOM, LLC

12 **UNITED STATES DISTRICT COURT**
13 **CENTRAL DISTRICT OF CALIFORNIA**

14 2BCOM, LLC.,

15 Plaintiff,

16 vs.

17 TP-LINK USA CORPORATION d/b/a
18 TP-LINK NORTH AMERICA, INC.,

19 Defendant.

Case No. 8:20-cv-00708

**COMPLAINT FOR PATENT
INFRINGEMENT**

JURY TRIAL DEMANDED

witkow | baskin

1 **COMPLAINT FOR PATENT INFRINGEMENT**

2 Plaintiff 2BCom, LLC (“Plaintiff” or “2BCom”) files this Complaint against
3 Defendant TP-Link USA Corporation d/b/a TP-Link North America, Inc. (“TP-Link”
4 or “Defendant”) for patent infringement and by and through its undersigned attorneys,
5 hereby prays to this honorable Court for relief and remedy based on the following:

6 **NATURE OF THE CASE**

7 1. This is an action for patent infringement arising under the patent laws of
8 the United States, 2BCom holds the rights in U.S. Patent Nos. 6,885,643 (“the ‘643
9 patent”), 6,928,166 (“the ‘166 patent”), 7,039,445 (“the ‘445 patent”), 7,127,210 (“the
10 ‘210 patent”), and 7,460,477 (“the ‘477 patent”). The United States patent laws grant
11 the holder of a patent the right to exclude infringers from making, using, selling or
12 importing the invention claimed in a patent, and to recover damages for the infringer’s
13 violations of these rights, and to recover treble damages where the infringer willingly
14 infringed the patent. Under 35 U.S.C. § 282(a), the ‘643 patent, the ‘166 patent, the
15 ‘445 patent, the ‘210 patent, and the ‘477 patent are entitled to a presumption of
16 validity. 2BCom is suing Defendant for infringing its patents and doing so willfully.
17 2BCom seeks to recover damages from Defendant, including treble damages for
18 willful infringement.

19 **THE PARTIES**

20 2. 2BCom, LLC is a company, organized and existing under the laws of
21 Delaware, having a place of business at 1603 Orrington Ave, Suite 600, Evanston,
22 Illinois 60201.

23 3. Upon information and belief, Defendant TP-Link USA Corporation d/b/a
24 TP-Link North America, Inc. is a California corporation with a principal place of
25 business at 145 South State College Boulevard, Suite 400, Brea, California 92821.

26 4. Upon information and belief, Defendant manufactures, imports, and/or
27 sells wireless router and Bluetooth receiver products listed in **Exhibit 11** (“Accused
28 Products”).

JURISDICTION

1
2 5. This is an action for patent infringement arising under the patent laws of
3 the United States of America, more specifically under 35 U.S.C. § 100, *et seq.*,
4 including 35 U.S.C. §271. Subject matter jurisdiction is proper in this Court pursuant
5 to 28 U.S.C. §§ 1331 and 1338.

6 6. The Court has personal jurisdiction over Defendant because Defendant,
7 among other things, conducts business in, and avails itself of the laws of the State of
8 California. Upon information and belief, Defendant has a principal place of business
9 in this District. In addition, upon information and belief, Defendant through its own
10 acts and/or through the acts of its affiliated companies (acting as its agents or alter
11 egos) makes, uses, offers to sell, sells (directly or through intermediaries), imports,
12 licenses and/or supplies, in this District and elsewhere in the United States, products,
13 through regular distribution channels, knowing such products would be used, offered
14 for sale and/or sold in this District. Plaintiff’s cause of action arises directly from
15 Defendant’s business contacts and other activities in the State of California and in this
16 District.

VENUE

17
18 7. Venue properly lies within this judicial district and division, pursuant to
19 28 U.S.C. §§ 1391(b), (c), and (d), and 1400(b).

20 8. Upon information and belief, Defendant has a principal place of business
21 in this District. Thus, Defendant resides in this District for the purposes of venue and
22 has committed acts of infringement within this judicial District, does business in this
23 District, and maintains a regular and established place of business in this District.

INFRINGEMENT OF U.S. PATENT NO. 6,885,643

24
25 9. 2BCom incorporates by reference the allegations set forth in the
26 preceding paragraphs.

27 10. On April 26, 2005, the ‘643 patent, entitled “Method And Device For
28 Facilitating Efficient Data Transfer Via A Wireless Communication Network,” was

1 duly and lawfully issued based upon an application filed by the inventors, Keiichi
2 Teramoto, Yoshiaki Takabatake, Junko Ami and Kensaku Fujimoto. A true and
3 correct copy of the '643 Patent is attached hereto as **Exhibit 1**.

4 11. 2BCom is the assignee and the owner of all right, title and interest in and
5 to the '643 patent and has the right to sue and recover damages for infringement
6 thereof.

7 12. Upon information and belief, Defendant has been and continues to be
8 engaged in making, using, importing, selling and/or offering for sale infringing
9 products, including, but not limited to, the Accused Products in the United States
10 generally, and in the Central District of California specifically. The Accused Products
11 are available for retail purchase through numerous retail websites in the United States,
12 such as www.amazon.com, www.bestbuy.com, www.walmart.com,
13 www.bhphotovideo.com and many others listed on the Defendant's website at
14 <https://www.tp-link.com/us/where-to-buy/>.

15 13. Upon information and belief, by acts including, but not limited to use,
16 making, importation, offers to sell, sales and marketing of products that fall within the
17 scope of at least claim 1 of the '643 patent, Defendant has directly infringed literally
18 and/or upon information and belief, equivalently, and is continuing to infringe the
19 '643 patent and is thus liable to 2BCom pursuant to 35 U.S.C. § 271.

20 14. As a non-limiting example of Defendant's infringement of the '643
21 patent, set forth in **Exhibit 2**, is a preliminary claim chart showing Defendant's
22 infringement of exemplary claim 1 of the '643 patent by the AC1750 Wireless Dual
23 Band Gigabit Router.

24 15. Defendant has indirectly infringed and continues to infringe at
25 least claim 1 of the '643 patent by inducement under 35 U.S.C. § 271(b). Defendant
26 has induced and continues to induce users and retailers of the Accused Products to
27 directly infringe at least claim 1 of the '643 patent.

28

1 16. Upon information and belief, Defendant’s knowingly induced
2 customers to use its Accused Products, including, for example, by promoting such
3 products online (e.g., <https://www.tp-link.com/us/>) and/or providing customers with
4 instructions and/or manuals for using the Accused Products through websites such as
5 <https://www.tp-link.com/us/>. Likewise, Defendant knowingly induced retailers to
6 market and sell the Accused Products via websites such as www.amazon.com,
7 www.bestbuy.com, www.walmart.com, www.bhphotovideo.com and many others
8 listed on the Defendant’s website at <https://www.tp-link.com/us/where-to-buy/>.

9 17. Defendant has been on notice of the ‘643 patent and Defendant’s
10 respective infringement of the ‘643 patent, since, at least, February 26, 2020, via letter
11 to Louis Liu, Chief Executive Officer of TP-Link USA Corporation, notifying the
12 Defendant of infringement of the patent.

13 18. Defendant’s infringement of the ‘643 patent is without consent of,
14 authority of, or license from 2BCom.

15 19. Upon information and belief, Defendant’s infringement of the ‘643 patent
16 is willful. This action, therefore, is “exceptional” within the meaning of 35 U.S.C. §
17 285 entitling 2BCom to its attorneys’ fees and expenses.

18 20. As a result of Defendant’s acts of infringement, 2BCom has suffered and
19 will continue to suffer damages in an amount to be proven at trial.

20 **INFRINGEMENT OF U.S. PATENT NO. 6,928,166**

21 21. 2BCom incorporates by reference the allegations set forth in the
22 preceding paragraphs.

23 22. On August 9, 2005 the ‘166 patent, entitled “Radio Communication
24 Device And User Authentication Method For Use Therewith,” was duly and lawfully
25 issued based upon an application filed by the inventor Junichi Yoshizawa. A true and
26 correct copy of the ‘166 Patent is attached hereto as **Exhibit 3**.

27
28

1 23. 2BCom is the assignee and the owner of all right, title and interest in and
2 to the '166 patent and has the right to sue and recover damages for infringement
3 thereof.

4 24. Upon information and belief, Defendant has been and continues to be
5 engaged in making, using, importing, selling and/or offering for sale infringing
6 products, including, but not limited to, the Accused Products in the United States
7 generally, and in the Central District of California specifically. The Accused Products
8 are available for retail purchase through numerous retail websites in the United States,
9 such as www.amazon.com, www.bestbuy.com, www.walmart.com,
10 www.bhphotovideo.com and many others listed on the Defendant's website at
11 <https://www.tp-link.com/us/where-to-buy/>.

12 25. Upon information and belief, by acts including, but not limited to use,
13 making, importation, offers to sell, sales and marketing of products that fall within the
14 scope of at least claim 13 of the '166 patent, Defendant has directly infringed literally
15 and/or upon information and belief, equivalently, and is continuing to infringe the
16 '166 patent and is thus liable to 2BCom pursuant to 35 U.S.C. § 271.

17 26. As a non-limiting example of Defendant's infringement of the '166
18 patent, set forth in **Exhibit 4**, is a preliminary claim chart showing Defendant's
19 infringement of exemplary claim 13 of the '166 patent by the AC1200 Wireless Dual
20 Band Router.

21 27. Defendant has indirectly infringed and continues to infringe at
22 least claim 13 of the '166 patent by inducement under 35 U.S.C. § 271(b). Defendant
23 has induced and continues to induce users and retailers of the Accused Products to
24 directly infringe at least claim 13 of the '166 patent.

25 28. Upon information and belief, Defendant's knowingly induced
26 customers to use its Accused Products, including, for example, by promoting such
27 products online (e.g., <https://www.tp-link.com/us/>) and/or providing customers with
28 instructions and/or manuals for using the Accused Products through websites such as

1 <https://www.tp-link.com/us/>. Likewise, Defendant knowingly induced retailers to
2 market and sell the Accused Products via websites such as www.amazon.com,
3 www.bestbuy.com, www.walmart.com, www.bhphotovideo.com and many others
4 listed on the Defendant's website at <https://www.tp-link.com/us/where-to-buy/>.

5 29. Defendant has been on notice of the '166 patent and Defendant's
6 respective infringement of the '166 patent, since, at least, February 26, 2020, via letter
7 to Louis Liu, Chief Executive Officer of TP-Link USA Corporation, notifying the
8 Defendant of infringement of the patent.

9 30. Defendant's infringement of the '166 patent is without consent of,
10 authority of, or license from 2BCom.

11 31. Upon information and belief, Defendant's infringement of the '166 patent
12 is willful. This action, therefore, is "exceptional" within the meaning of 35 U.S.C. §
13 285 entitling 2BCom to its attorneys' fees and expenses.

14 32. As a result of Defendant's acts of infringement, 2BCom has suffered and
15 will continue to suffer damages in an amount to be proven at trial.

16 **INFRINGEMENT OF U.S. PATENT NO. 7,039,445**

17 33. 2BCom incorporates by reference the allegations set forth in the
18 preceding paragraphs.

19 34. On May 2, 2006 the '445 patent, entitled "Communication System,
20 Communication Apparatus, and Communication Method," was duly and lawfully
21 issued based upon an application filed by the inventor Junichi Yoshizawa. A true and
22 correct copy of the '445 Patent is attached hereto as **Exhibit 5**.

23 35. 2BCom is the assignee and the owner of all right, title and interest in and
24 to the '445 patent and has the right to sue and recover damages for infringement
25 thereof.

26 36. Upon information and belief, Defendant has been and continues to be
27 engaged in making, using, importing, selling and/or offering for sale infringing
28 products, including, but not limited to, the Accused Products in the United States

1 generally, and in the Central District of California specifically. The Accused Products
2 are available for retail purchase through numerous retail websites in the United States,
3 such as www.amazon.com, www.bestbuy.com, www.walmart.com,
4 www.bhphotovideo.com and many others listed on the Defendant's website at
5 <https://www.tp-link.com/us/where-to-buy/>.

6 37. Upon information and belief, by acts including, but not limited to use,
7 making, importation, offers to sell, sales and marketing of products that fall within the
8 scope of at least claim 13 of the '445 patent, Defendant has directly infringed literally
9 and/or upon information and belief, equivalently, and is continuing to infringe the
10 '445 patent and is thus liable to 2BCom pursuant to 35 U.S.C. § 271.

11 38. As a non-limiting example of Defendant's infringement of the '445
12 patent, set forth in **Exhibit 6**, is a preliminary claim chart showing Defendant's
13 infringement of exemplary claim 13 of the '445 patent by the AC1900 Wireless MU-
14 MIMO Gigabit Router.

15 39. Defendant has indirectly infringed and continues to infringe at
16 least claim 13 of the '445 patent by inducement under 35 U.S.C. § 271(b). Defendant
17 has induced and continues to induce users and retailers of the Accused Products to
18 directly infringe at least claim 13 of the '445 patent.

19 40. Upon information and belief, Defendant's knowingly induced
20 customers to use its Accused Products, including, for example, by promoting such
21 products online (e.g., <https://www.tp-link.com/us/>) and/or providing customers with
22 instructions and/or manuals for using the Accused Products through websites such as
23 <https://www.tp-link.com/us/>. Likewise, Defendant knowingly induced retailers to
24 market and sell the Accused Products via websites such as www.amazon.com,
25 www.bestbuy.com, www.walmart.com, www.bhphotovideo.com and many others
26 listed on the Defendant's website at <https://www.tp-link.com/us/where-to-buy/>.

27 41. Defendant has been on notice of the '445 patent and Defendant's
28 respective infringement of the '445 patent, since, at least, February 26, 2020, via letter

1 to Louis Liu, Chief Executive Officer of TP-Link USA Corporation, notifying the
2 Defendant of infringement of the patent.

3 42. Defendant's infringement of the '445 patent is without consent of,
4 authority of, or license from 2BCom.

5 43. Upon information and belief, Defendant's infringement of the '445 patent
6 is willful. This action, therefore, is "exceptional" within the meaning of 35 U.S.C. §
7 285 entitling 2BCom to its attorneys' fees and expenses.

8 44. As a result of Defendant's acts of infringement, 2BCom has suffered and
9 will continue to suffer damages in an amount to be proven at trial

10 **INFRINGEMENT OF U.S. PATENT NO. 7,127,210**

11 45. 2BCom incorporates by reference the allegations set forth in the
12 preceding paragraphs.

13 46. On October 24, 2006 the '210 patent, entitled "Wireless Communication
14 Apparatus," was duly and lawfully issued based upon an application filed by the
15 inventor Kazunori Aoyagi. A true and correct copy of the '210 Patent is attached
16 hereto as **Exhibit 7**.

17 47. 2BCom is the assignee and the owner of all right, title and interest in and
18 to the '210 patent and has the right to sue and recover damages for infringement
19 thereof.

20 48. Upon information and belief, Defendant has been and continues to be
21 engaged in making, using, importing, selling and/or offering for sale infringing
22 products, including, but not limited to, the Accused Products in the United States
23 generally, and in the Central District of California specifically. The Accused Products
24 are available for retail purchase through numerous retail websites in the United States,
25 such as www.amazon.com, www.bestbuy.com, www.walmart.com,
26 www.bhphotovideo.com and many others listed on the Defendant's website at
27 <https://www.tp-link.com/us/where-to-buy/>.

witkow | baskin

1 49. Upon information and belief, by acts including, but not limited to use,
2 making, importation, offers to sell, sales and marketing of products that fall within the
3 scope of at least claim 20 of the '210 patent, Defendant has directly infringed literally
4 and/or upon information and belief, equivalently, and is continuing to infringe the
5 '210 patent and is thus liable to 2BCom pursuant to 35 U.S.C. § 271.

6 50. As a non-limiting example of Defendant's infringement of the '210
7 patent, set forth in **Exhibit 8**, is a preliminary claim chart showing Defendant's
8 infringement of exemplary claim 20 of the '210 patent by the Bluetooth Music
9 Receiver.

10 51. Defendant has indirectly infringed and continues to infringe at
11 least claim 20 of the '210 patent by inducement under 35 U.S.C. § 271(b). Defendant
12 has induced and continues to induce users and retailers of the Accused Products to
13 directly infringe at least claim 20 of the '210 patent.

14 52. Upon information and belief, Defendant's knowingly induced
15 customers to use its Accused Products, including, for example, by promoting such
16 products online (e.g., <https://www.tp-link.com/us/>) and/or providing customers with
17 instructions and/or manuals for using the Accused Products through websites such as
18 <https://www.tp-link.com/us/>. Likewise, Defendant knowingly induced retailers to
19 market and sell the Accused Products via websites such as www.amazon.com,
20 www.bestbuy.com, www.walmart.com, www.bhphotovideo.com and many others
21 listed on the Defendant's website at <https://www.tp-link.com/us/where-to-buy/>.

22 53. Defendant has been on notice of the '210 patent and Defendant's
23 respective infringement of the '210 patent, since, at least, February 26, 2020, via letter
24 to Louis Liu, Chief Executive Officer of TP-Link USA Corporation, notifying the
25 Defendant of infringement of the patent.

26 54. Defendant's infringement of the '210 patent is without consent of,
27 authority of, or license from 2BCom.
28

1 55. Upon information and belief, Defendant’s infringement of the ‘210 patent
2 is willful. This action, therefore, is “exceptional” within the meaning of 35 U.S.C. §
3 285 entitling 2BCom to its attorneys’ fees and expenses.

4 56. As a result of Defendant’s acts of infringement, 2BCom has suffered and
5 will continue to suffer damages in an amount to be proven at trial.

6 **INFRINGEMENT OF U.S. PATENT NO. 7,460,477**

7 57. 2BCom incorporates by reference the allegations set forth in the
8 preceding paragraphs.

9 58. On December 2, 2008 the ‘477 patent, entitled “Electronic Apparatus
10 with Communication Device,” was duly and lawfully issued based upon an
11 application filed by the inventors, Koichi Yata and Tooru Homma. A true and correct
12 copy of the ‘477 Patent is attached hereto as **Exhibit 9**.

13 59. 2BCom is the assignee and the owner of all right, title and interest in and
14 to the ‘477 patent and has the right to sue and recover damages for infringement
15 thereof.

16 60. Upon information and belief, Defendant has been and continues to be
17 engaged in making, using, importing, selling and/or offering for sale infringing
18 products, including, but not limited to, the Accused Products in the United States
19 generally, and in the Central District of California specifically. The Accused Products
20 are available for retail purchase through numerous retail websites in the United States,
21 such as www.amazon.com, www.bestbuy.com, www.walmart.com,
22 www.bhphotovideo.com and many others listed on the Defendant’s website at
23 <https://www.tp-link.com/us/where-to-buy/>.

24 61. Upon information and belief, by acts including, but not limited to use,
25 making, importation, offers to sell, sales and marketing of products that fall within the
26 scope of at least claim 7 of the ‘477 patent, Defendant has directly infringed literally
27 and/or upon information and belief, equivalently, and is continuing to infringe the
28 ‘477 patent and is thus liable to 2BCom pursuant to 35 U.S.C. § 271.

1 62. As a non-limiting example of Defendant’s infringement of the ‘477
2 patent, set forth in **Exhibit 10**, is a preliminary claim chart showing Defendant’s
3 infringement of exemplary claim 7 of the ‘477 patent by the AC1200 Wireless Dual
4 Band Router.

5 63. Defendant has indirectly infringed and continues to infringe at
6 least claim 7 of the ‘477 patent by inducement under 35 U.S.C. § 271(b). Defendant
7 has induced and continues to induce users and retailers of the Accused Products to
8 directly infringe at least claim 7 of the ‘477 patent.

9 64. Upon information and belief, Defendant’s knowingly induced
10 customers to use its Accused Products, including, for example, by promoting such
11 products online (e.g., <https://www.tp-link.com/us/>) and/or providing customers with
12 instructions and/or manuals for using the Accused Products through websites such as
13 <https://www.tp-link.com/us/>. Likewise, Defendant knowingly induced retailers to
14 market and sell the Accused Products via websites such as www.amazon.com,
15 www.bestbuy.com, www.walmart.com, www.bhphotovideo.com and many others
16 listed on the Defendant’s website at <https://www.tp-link.com/us/where-to-buy/>.

17 65. Defendant has been on notice of the ‘477 patent and Defendant’s
18 respective infringement of the ‘477 patent, since, at least, February 26, 2020, via letter
19 to Louis Liu, Chief Executive Officer of TP-Link USA Corporation, notifying the
20 Defendant of infringement of the patent.

21 66. Defendant’s infringement of the ‘477 patent is without consent of,
22 authority of, or license from 2BCom.

23 67. Upon information and belief, Defendant’s infringement of the ‘477 patent
24 is willful. This action, therefore, is “exceptional” within the meaning of 35 U.S.C. §
25 285 entitling 2BCom to its attorneys’ fees and expenses.

26 68. As a result of Defendant’s acts of infringement, 2BCom has suffered and
27 will continue to suffer damages in an amount to be proven at trial.
28

PRAYER FOR RELIEF

WHEREFORE, 2BCom requests this Court enter judgment as follows:

- A. That the '643 patent, the '166 patent, the '445 patent, the '210 patent, and the '477 patent are valid and enforceable;
- B. That Defendant has directly and indirectly infringed at least claim 1 of the '643 patent, claim 13 of the '166 patent, claim 13 of the '445 patent, claim 20 of the '210 patent, and claim 7 of the '477 patent.
- C. That such infringement is willful;
- D. That Defendant account for and pay to 2BCom all damages pursuant to 35 U.S.C. § 284 to adequately compensate 2BCom for Defendant's infringement of the '643 patent, the '166 patent, the '445 patent, the '210 patent, and the '477 patent, but in no event less than a reasonable royalty for the use made by Defendant of the invention set forth in the '643 patent, the '166 patent, the '445 patent, the '210 patent, and the '477 patent;
- E. That 2BCom receives enhanced damages, in the form of treble damages, pursuant to 35 U.S.C. § 284;
- F. That this is an exceptional case under 35 U.S.C. § 285;
- G. That Defendant pay 2BCom all of 2BCom's reasonable attorneys' fees and expenses pursuant to 35 U.S.C. § 285;
- H. That 2BCom be granted pre-judgment and post-judgment interest in accordance with 35 U.S.C. § 284 on the damages caused to it by reason of Defendant's infringement of the '643 patent, the '166 patent, the '445 patent, the '210 patent, and the '477 patent, including pre-judgment and post-judgment interest on any enhanced damages or attorneys' fees award;
- I. That costs be awarded in accordance with 35 U.S.C. § 284 to 2BCom; and
- J. That 2BCom be granted such other and further relief as the Court may deem just and proper under the circumstances.

DEMAND FOR JURY TRIAL

1
2
3
4
5
6
7
8
9
10
11
12
13
14
15
16
17
18
19
20
21
22
23
24
25
26
27
28

2BCom hereby demands a trial by jury on all issues so triable in this action.

Dated: April 9, 2020

witkow | baskin

By: /s/ Brandon J. Witkow
Brandon J. Witkow
Cory A. Baskin

Attorneys for *Plaintiff* 2BCOM, LLC.

witkow | baskin

EXHIBIT 1

(12) **United States Patent**
Teramoto et al.

(10) **Patent No.:** US 6,885,643 B1
 (45) **Date of Patent:** Apr. 26, 2005

(54) **METHOD AND DEVICE FOR FACILITATING EFFICIENT DATA TRANSFER VIA A WIRELESS COMMUNICATION NETWORK**

JP 8-116424 5/1996
 JP 10-154996 6/1998
 JP 10-164107 6/1998
 WO WO 95/35002 12/1995

(75) Inventors: **Keiichi Teramoto**, Tokyo (JP);
Yoshiaki Takabatake, Kanagawa (JP);
Junko Ami, Tokyo (JP); **Kensaku Fujimoto**, Kanagawa (JP)

OTHER PUBLICATIONS

U.S. Appl. No. 09/343,509.*

(73) Assignee: **Kabushiki Kaisha Toshiba**, Kawasaki (JP)

* cited by examiner

(*) Notice: Subject to any disclaimer, the term of this patent is extended or adjusted under 35 U.S.C. 154(b) by 756 days.

Primary Examiner—Dang Ton
Assistant Examiner—Robert C Scheibel
 (74) *Attorney, Agent, or Firm*—Oblon, Spivak, McClelland, Maier & Neustadt, P.C.

(21) Appl. No.: **09/671,012**

(57) **ABSTRACT**

(22) Filed: **Sep. 28, 2000**

A wireless network system capable of controlling highly efficient transfer of AV data by an upper application, using information indicating a wireless link condition that varies dynamically is disclosed. In this wireless network system, a wireless terminal and a wire gateway apparatus each store collected wireless link condition information in a descriptor. An upper application on the wireless terminal reads the descriptor at said terminal device and obtains wireless LAN link condition information. The wireless gateway apparatus makes notification to a wireless terminal of a VTR, for example, that actually exists in a 1394 terminal as if it existed as a sub-unit in the local terminal device. The wireless terminal accesses the collected wireless link condition information and selects a AV/C command to be sent to the VTR sub-unit of the wireless gateway apparatus. The wireless terminal transfers the play command for playback to the wireless gateway apparatus. The wireless gateway apparatus transfers the play command to a VTR sub-unit within a terminal on the wired network. In accordance with this action, the VTR sub-unit within the terminal on the wired network starts transfer of AV data.

(30) **Foreign Application Priority Data**

Sep. 30, 1999 (JP) P 11-280651

(51) **Int. Cl.**⁷ **H04L 12/26**

(52) **U.S. Cl.** **370/252; 370/338; 370/463; 370/469**

(58) **Field of Search** **370/252–253, 370/338, 469, 231–236, 463, 329**

(56) **References Cited**

U.S. PATENT DOCUMENTS

5,764,699 A 6/1998 Needham et al.
 6,208,620 B1 * 3/2001 Sen et al. 370/231
 6,272,148 B1 * 8/2001 Takagi et al. 370/469
 6,301,609 B1 * 10/2001 Aravamudan et al. 709/207
 6,480,889 B1 * 11/2002 Saito et al. 709/220
 6,728,244 B1 * 4/2004 Takabatake 370/392
 6,845,090 B1 * 1/2005 Takabatake 370/338

FOREIGN PATENT DOCUMENTS

EP 0 844 769 5/1998

23 Claims, 16 Drawing Sheets

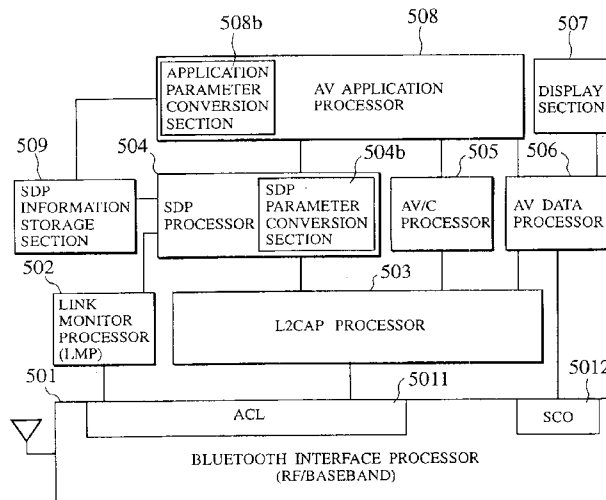

FIG. 1

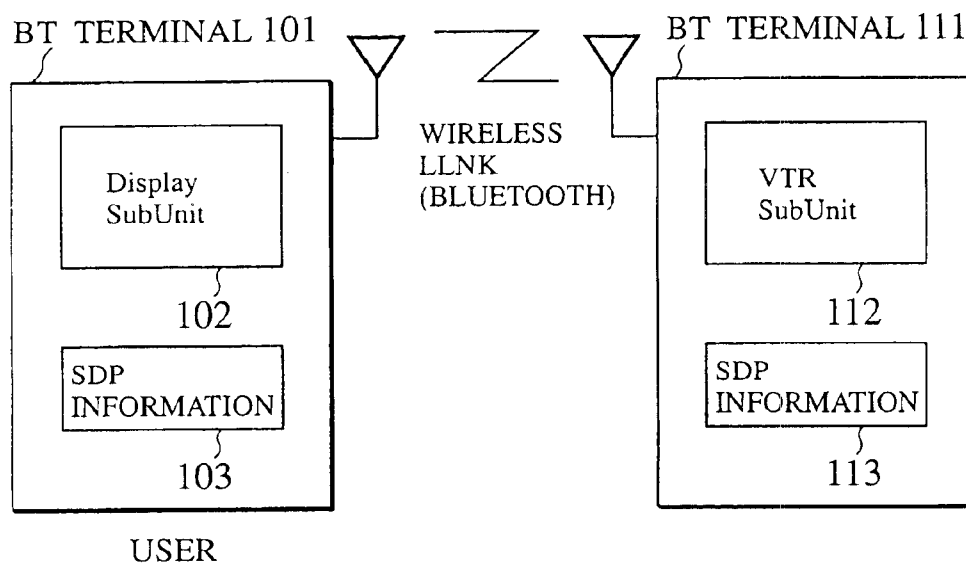

FIG.2

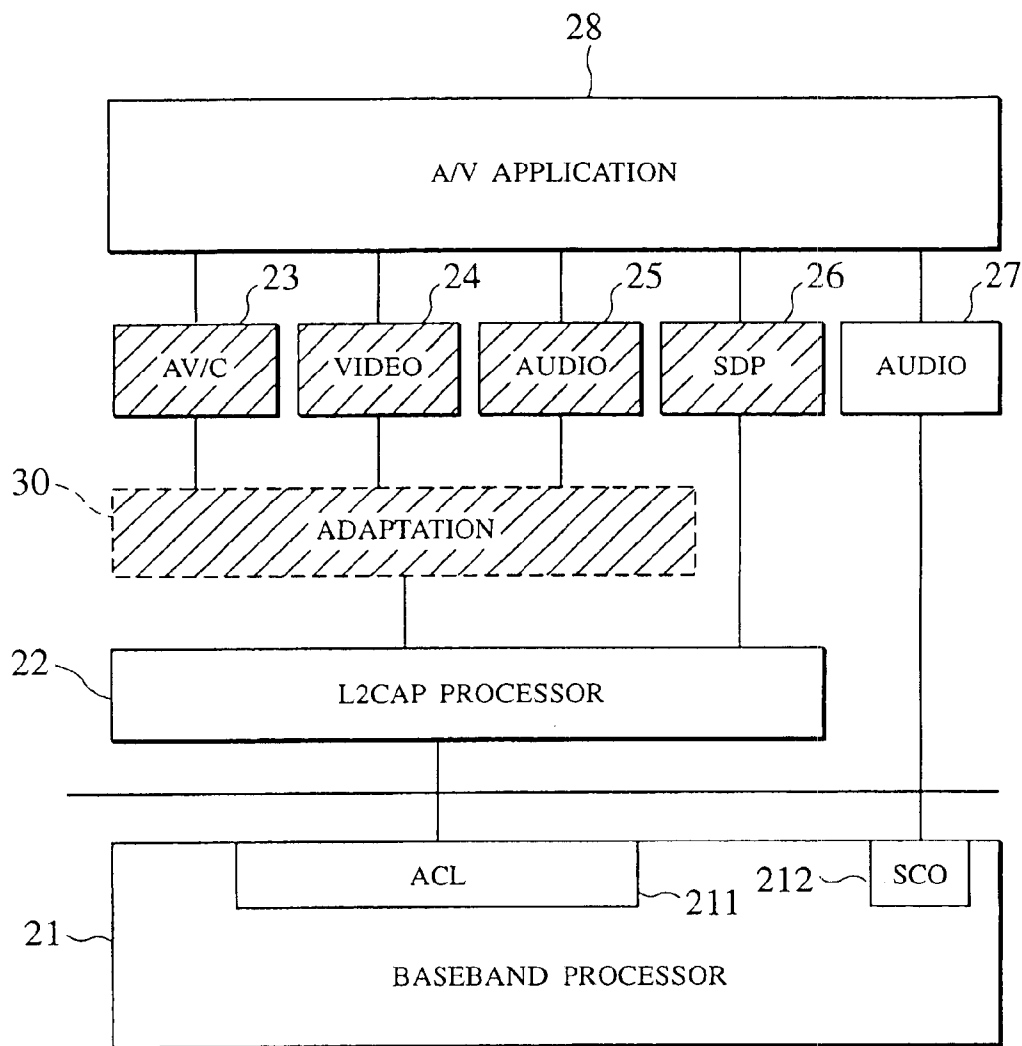

FIG.3

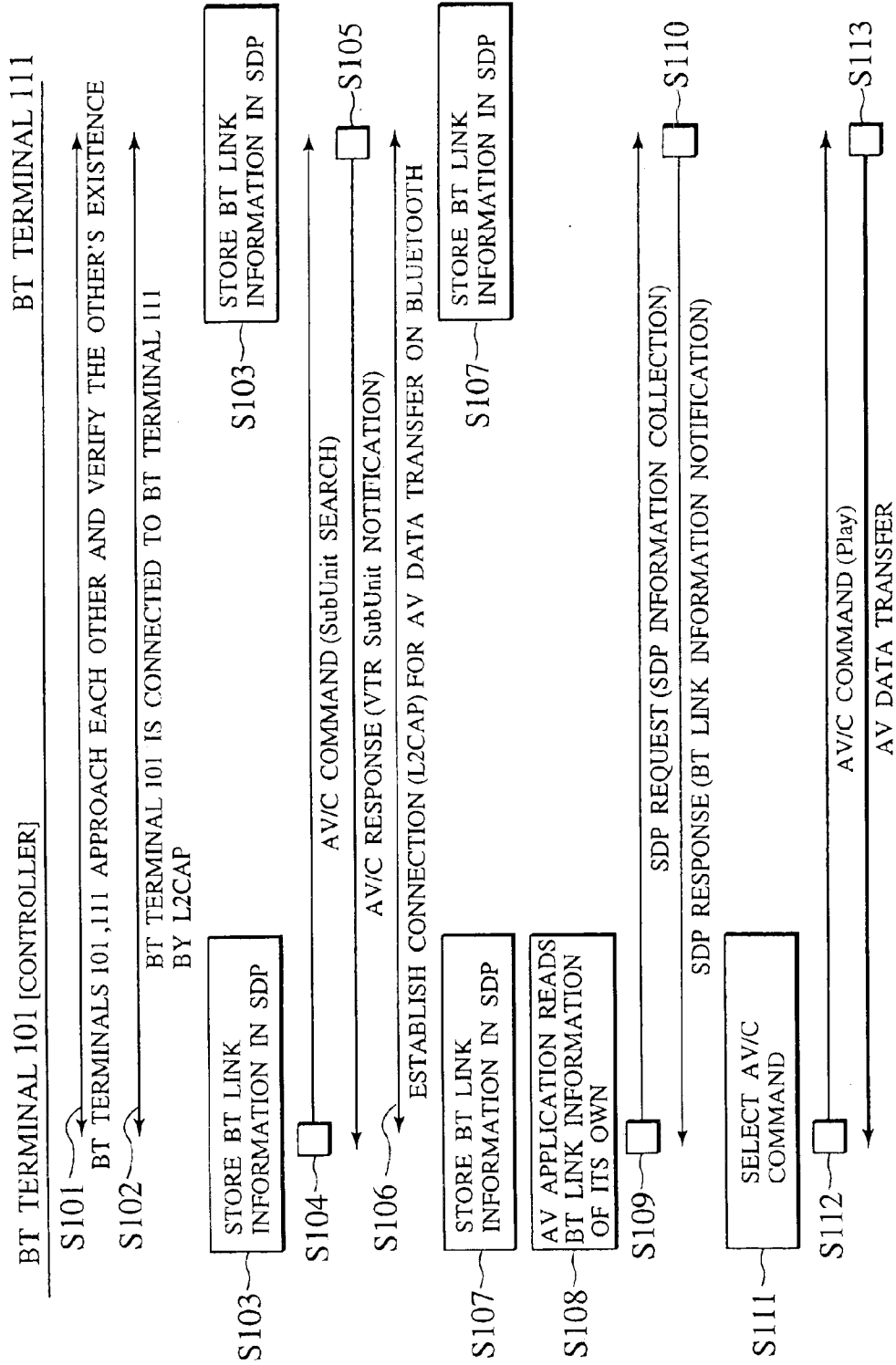

FIG.4

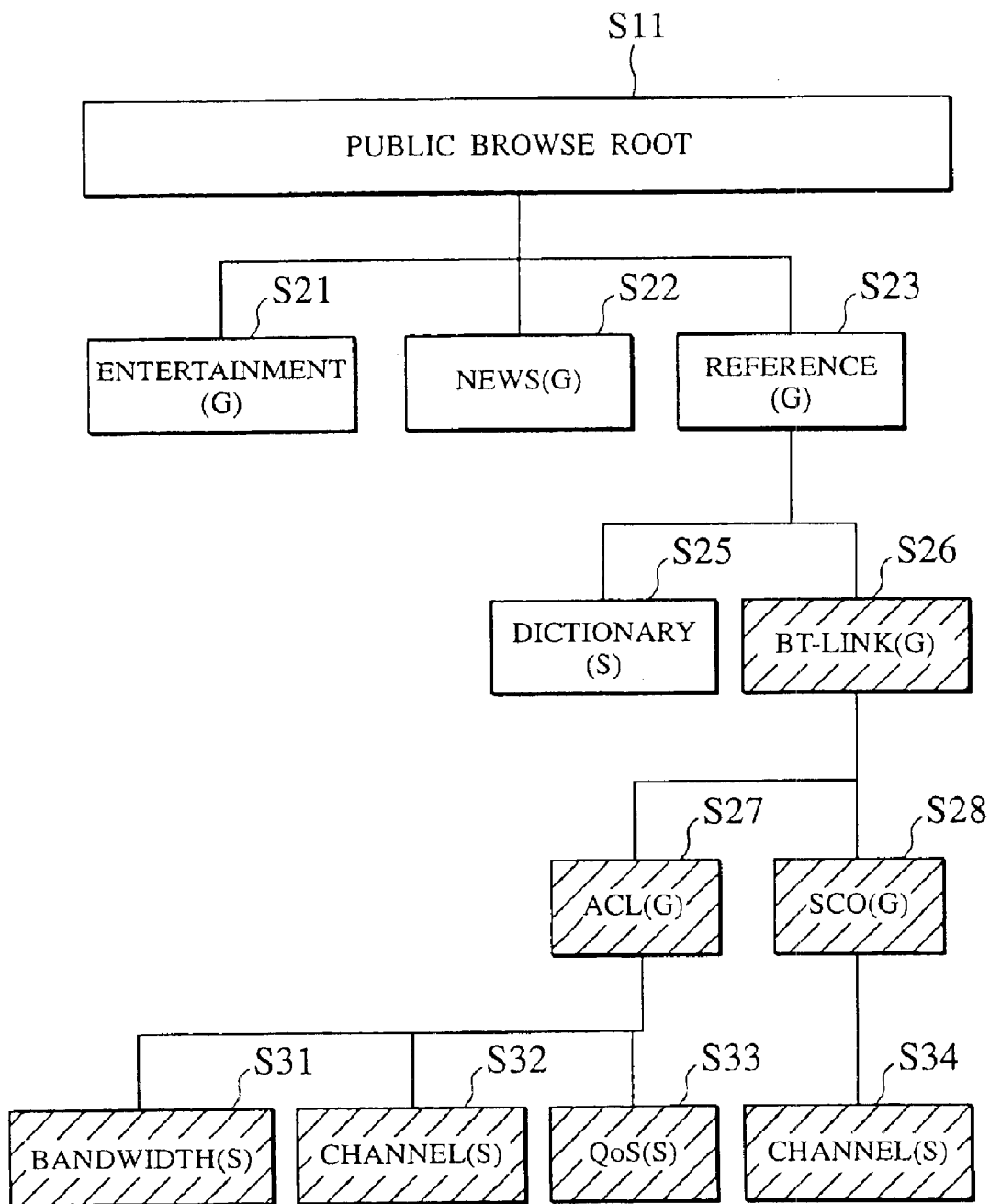

FIG. 5

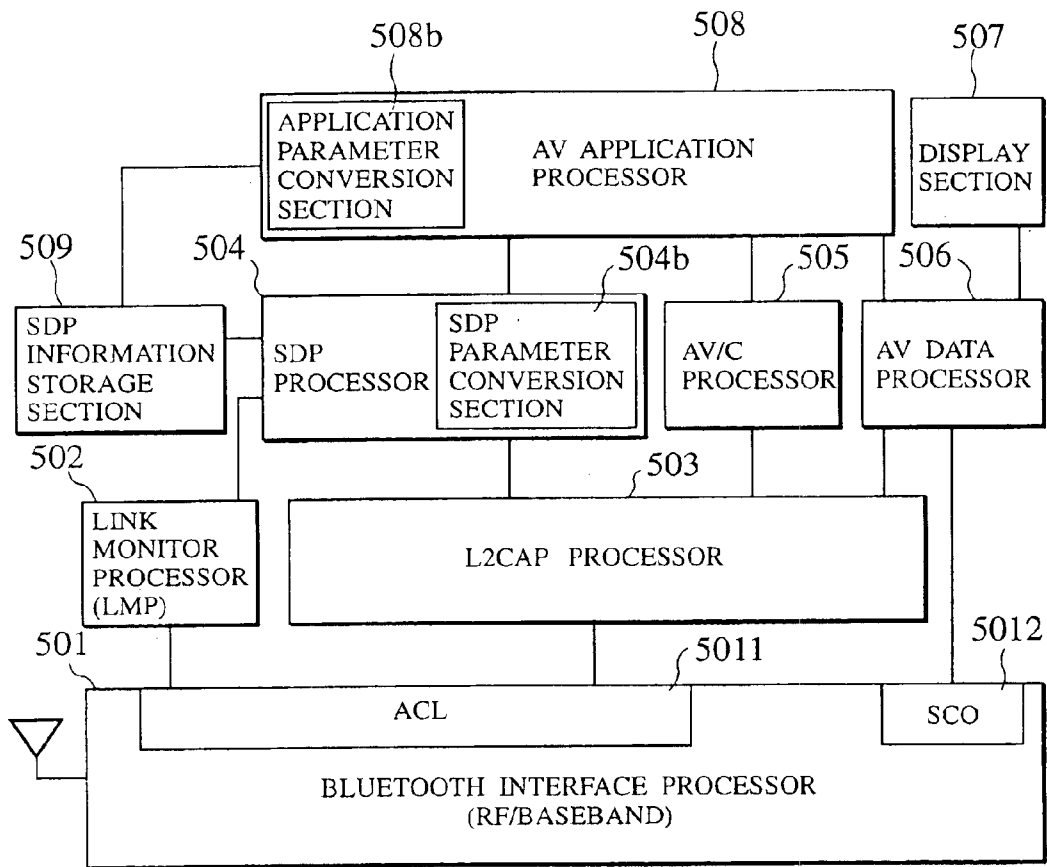

FIG.6

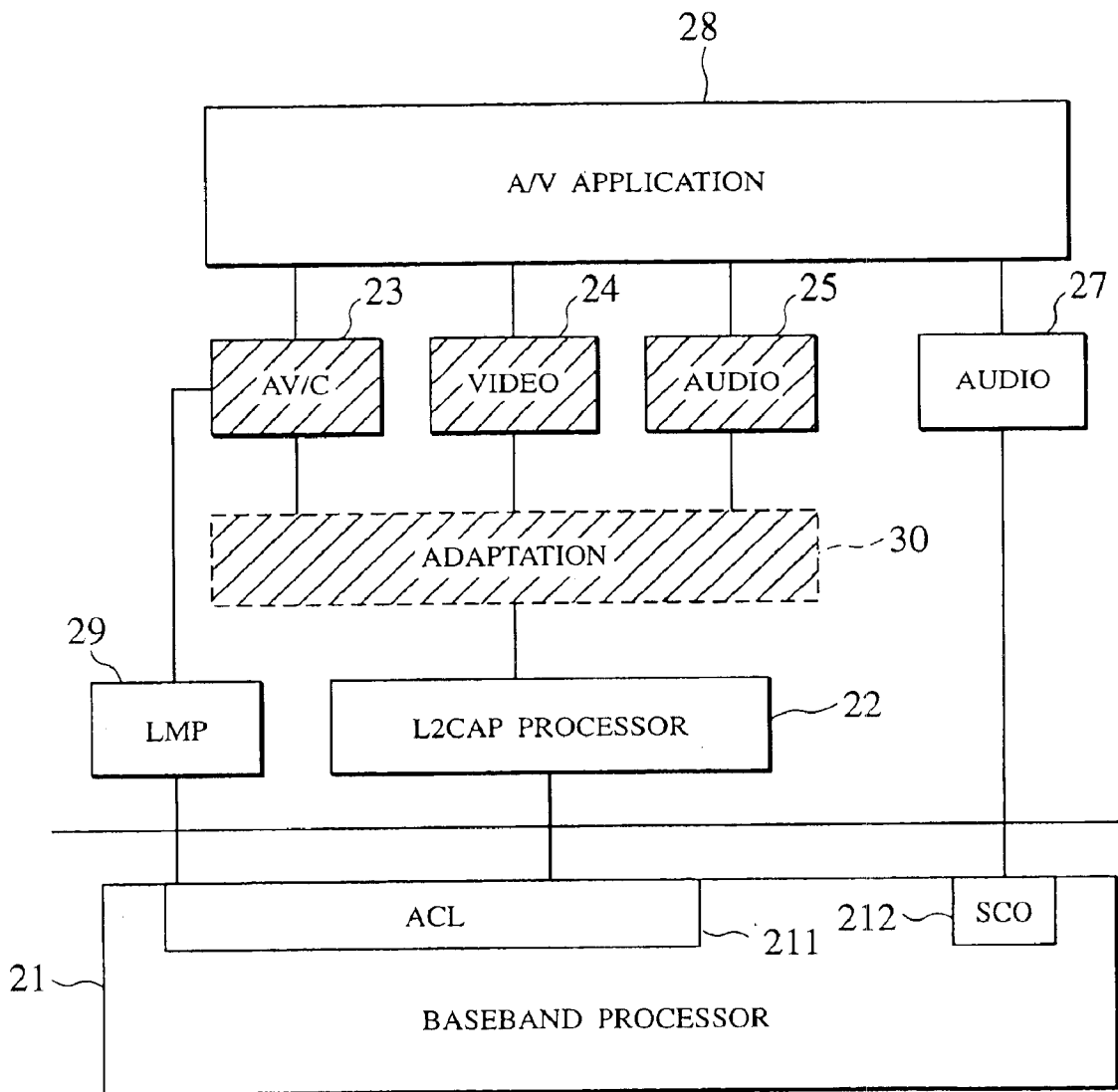

FIG. 7

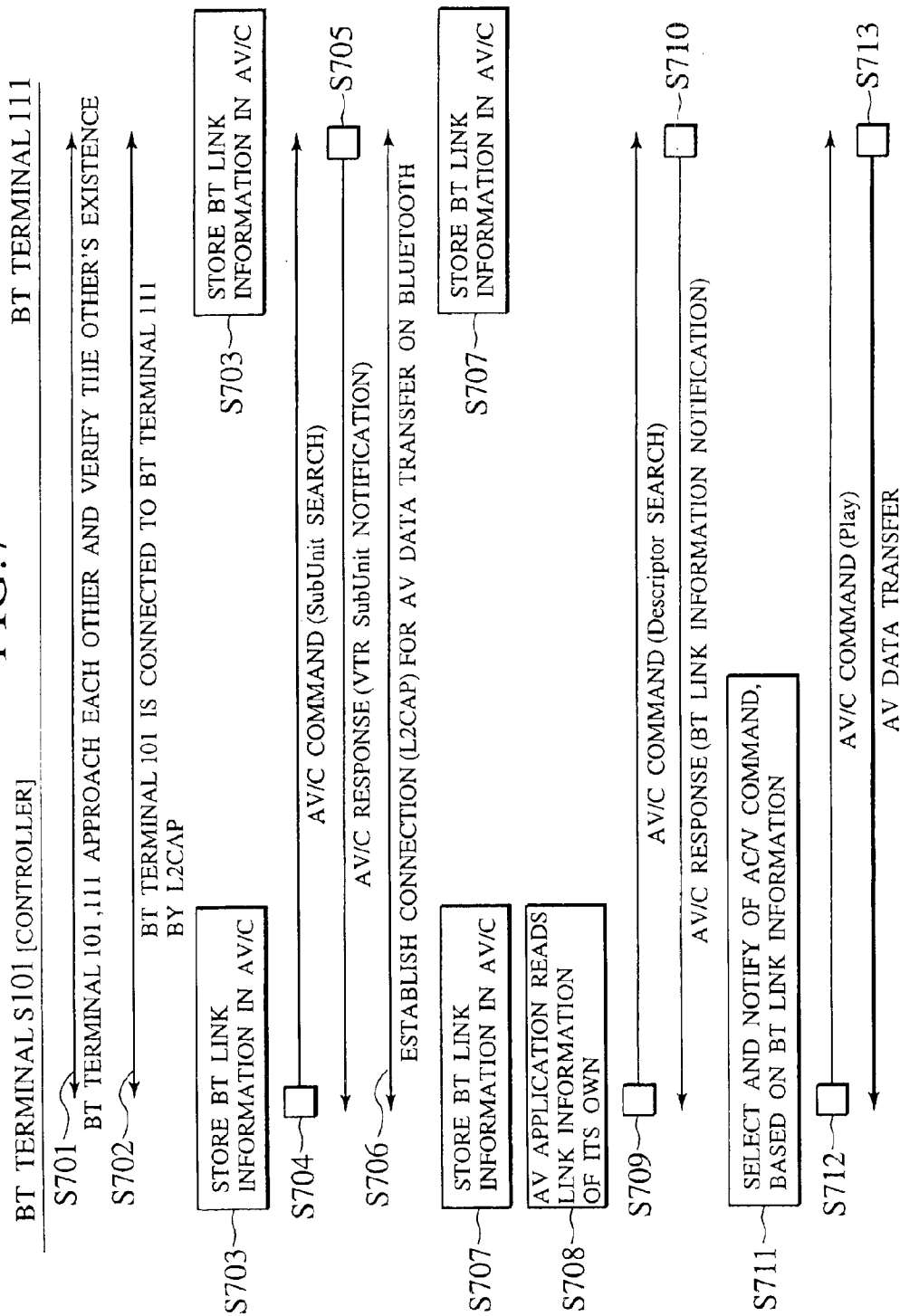

FIG. 8

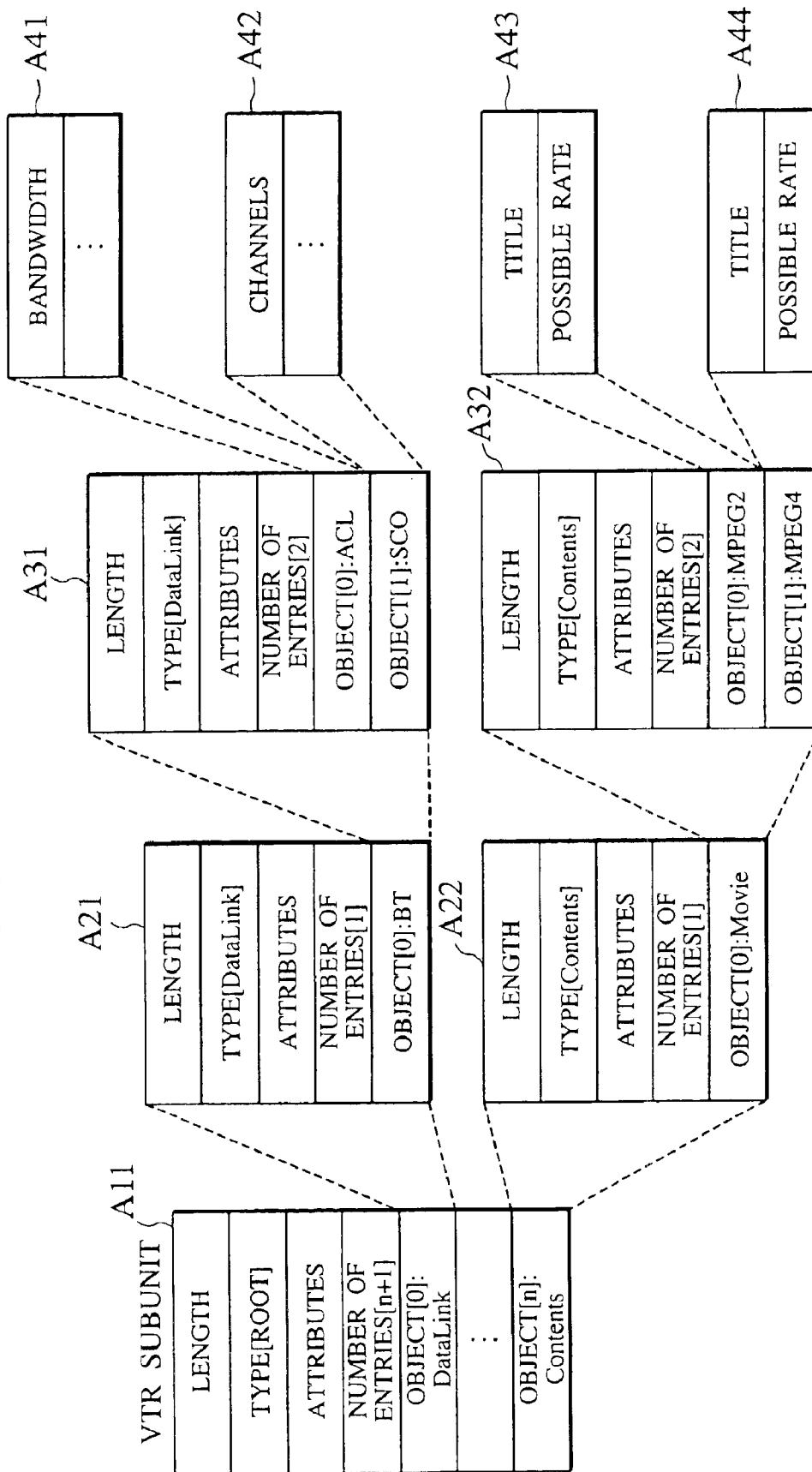

FIG. 9

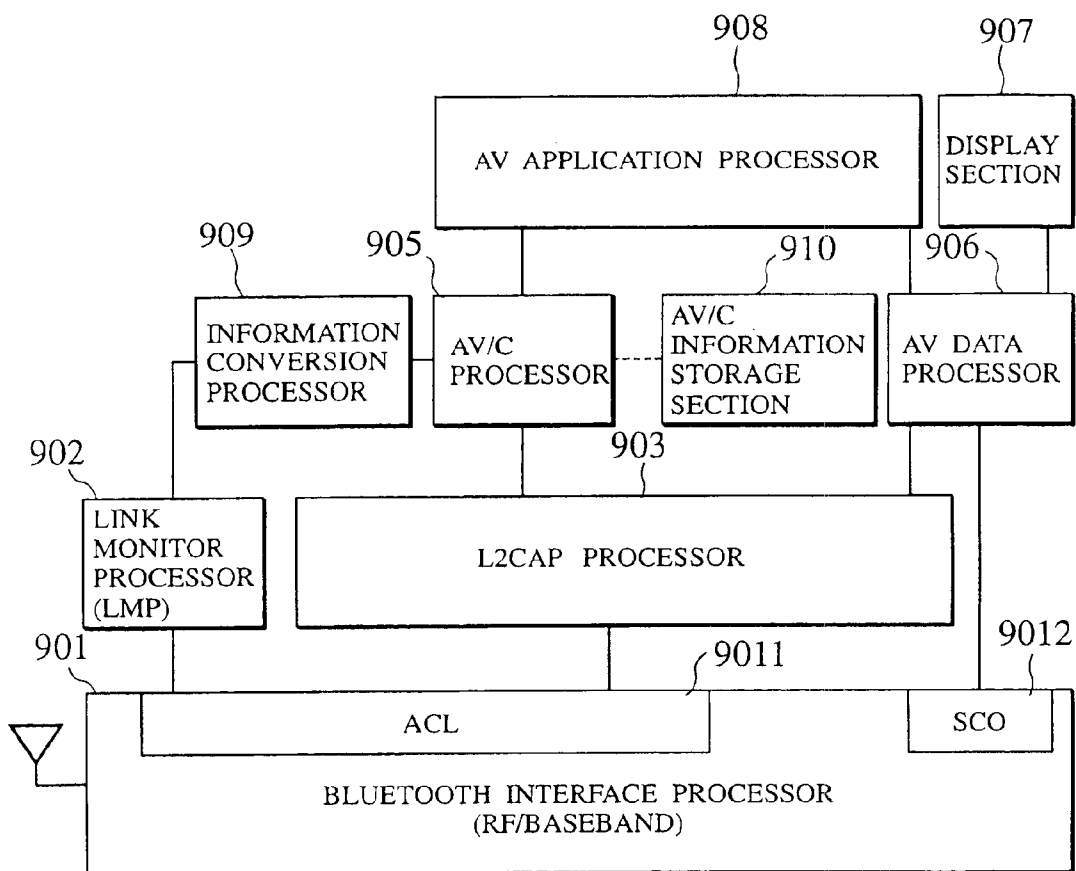
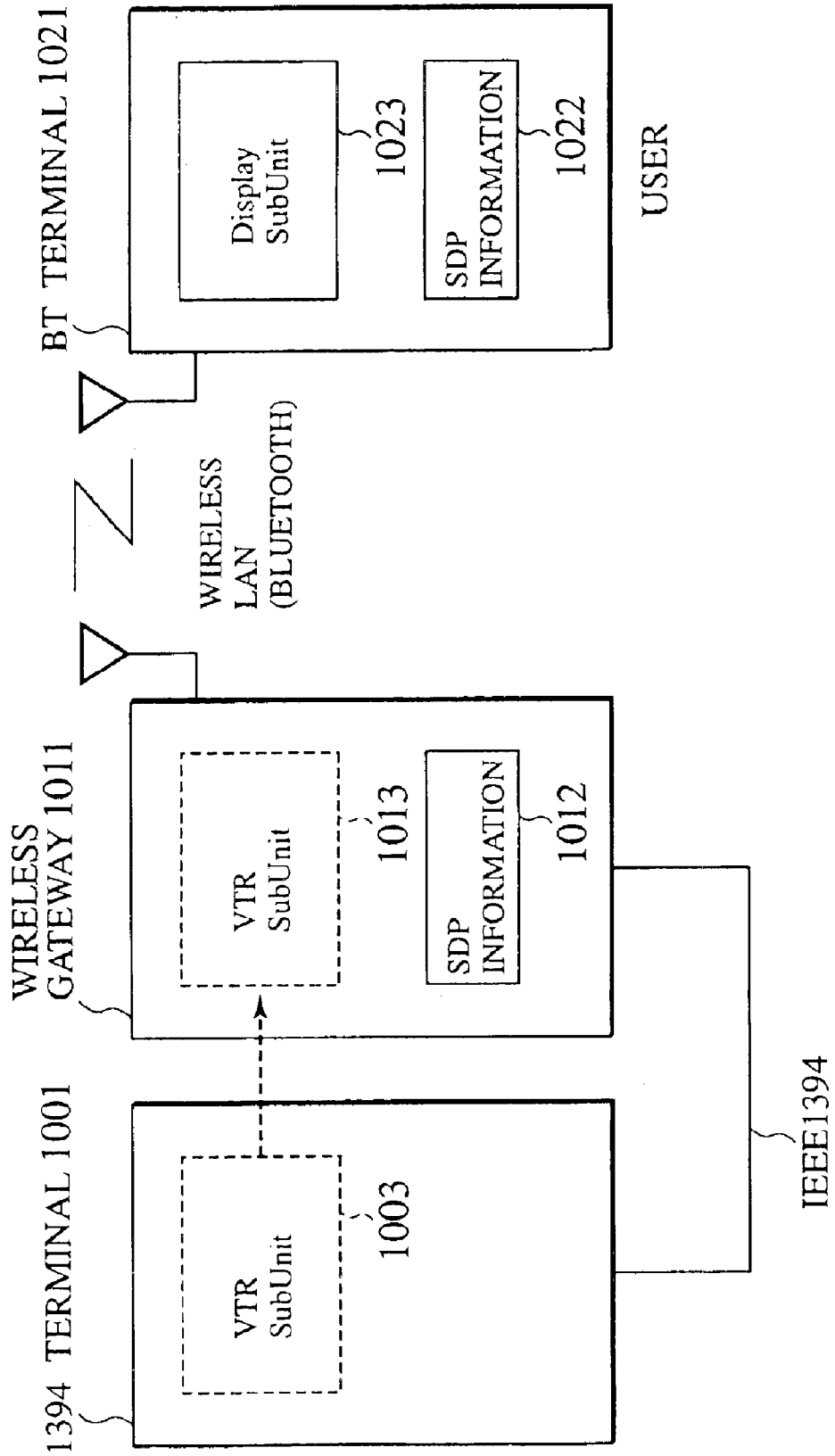

FIG. 10



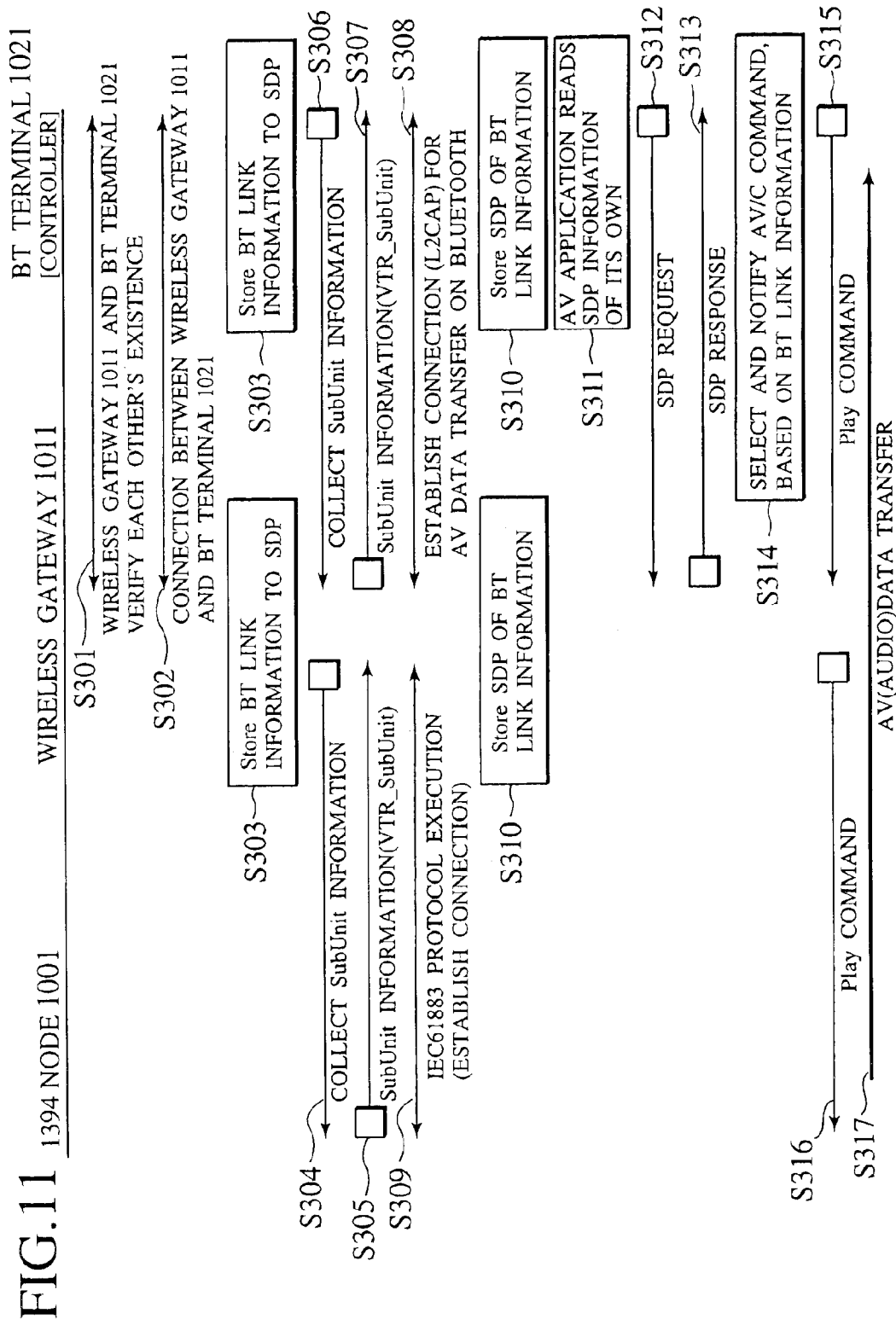

FIG. 12

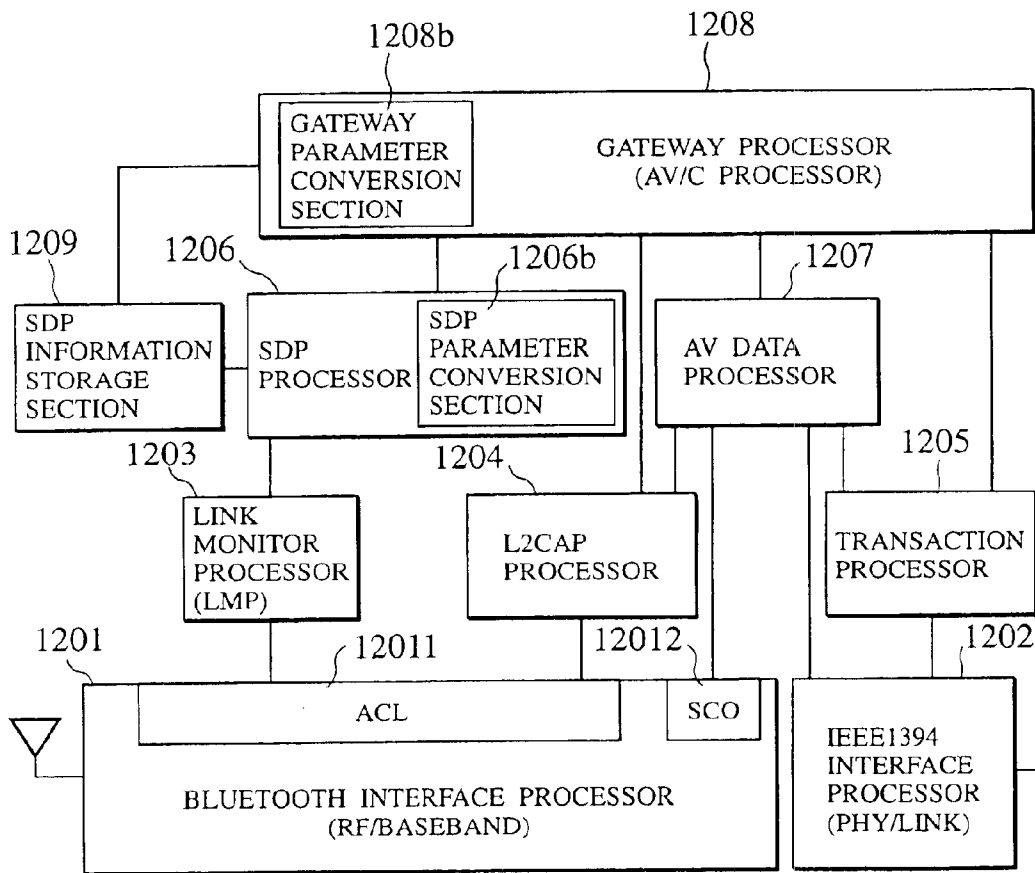

FIG. 13

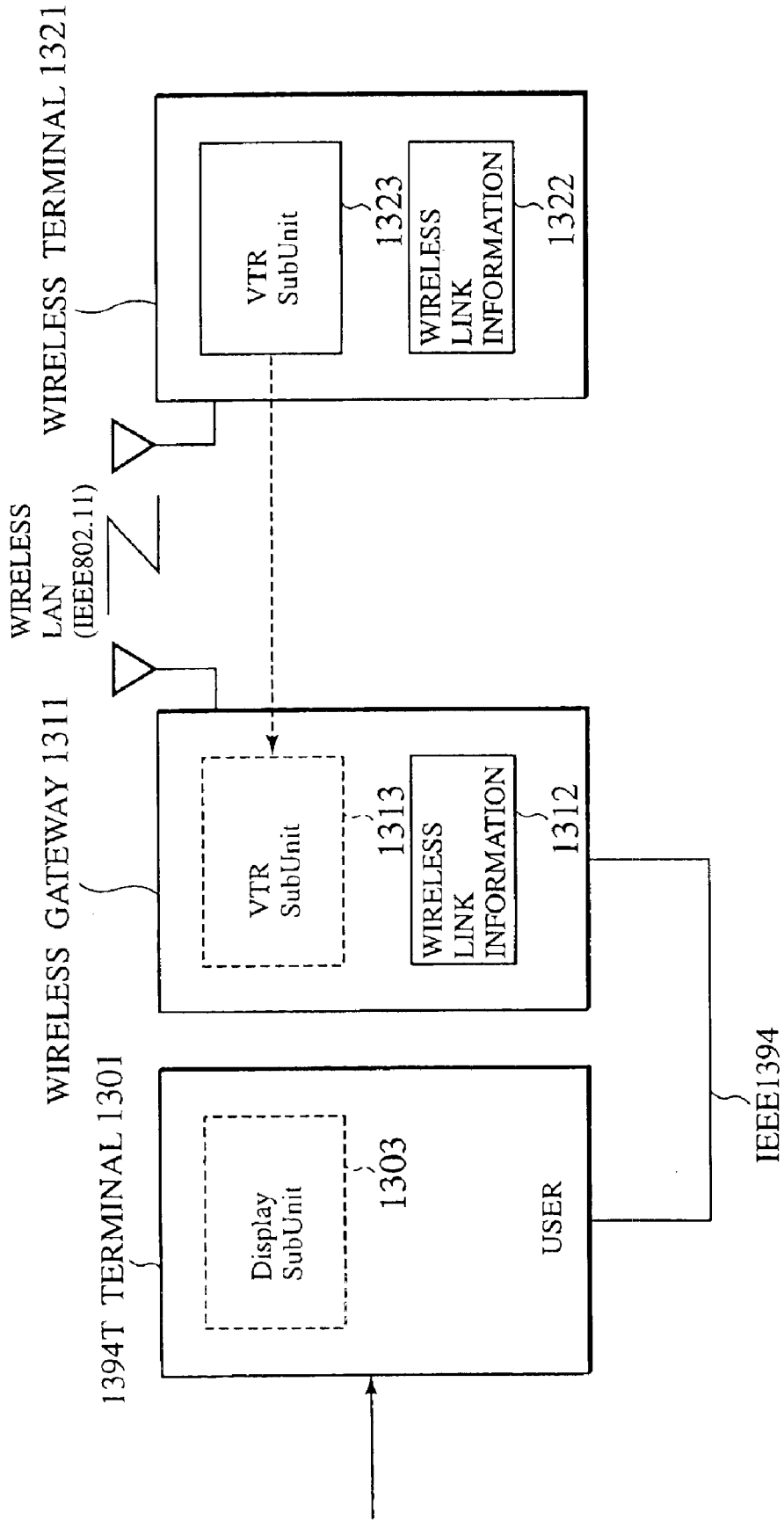
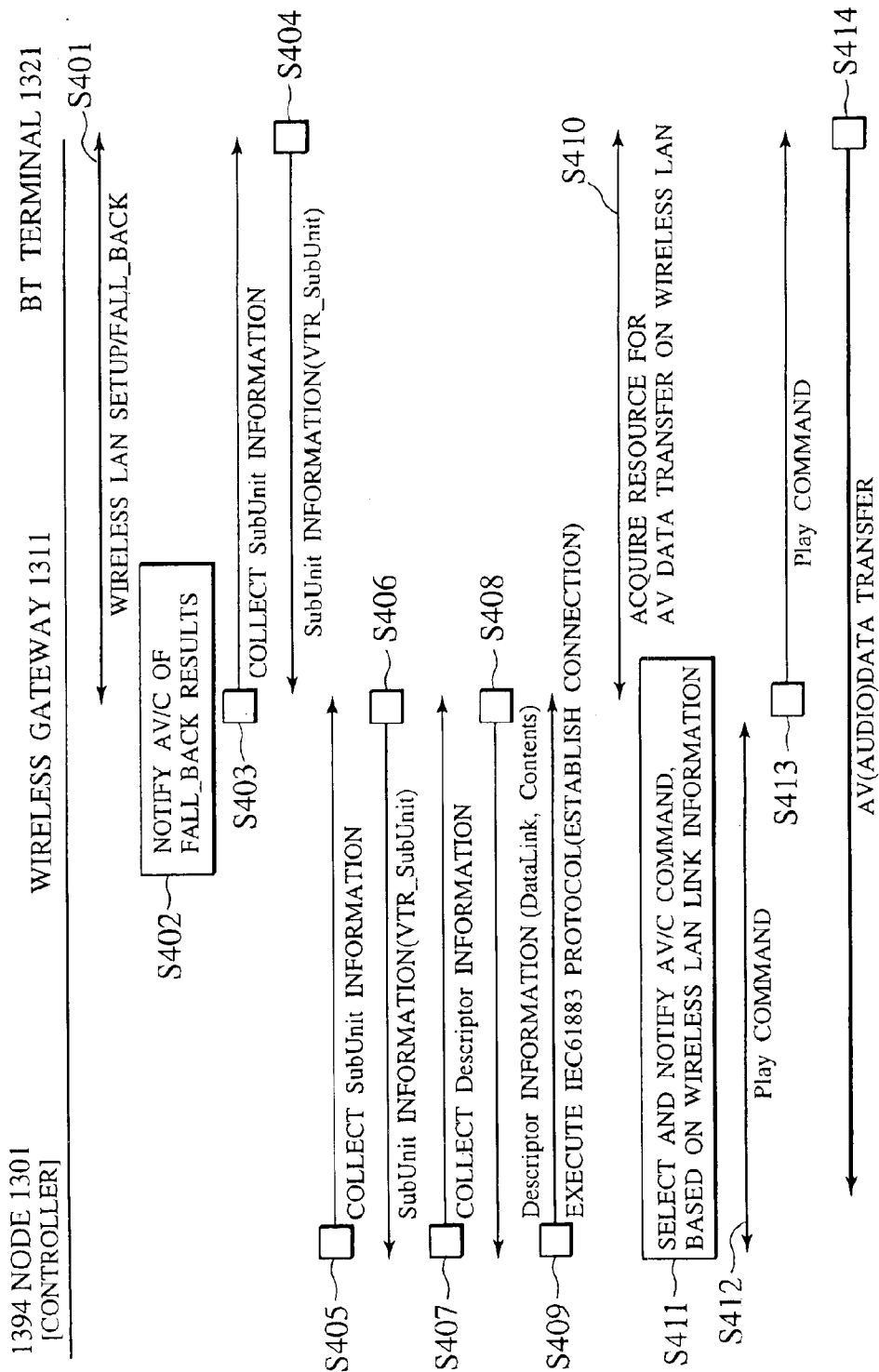

FIG. 14



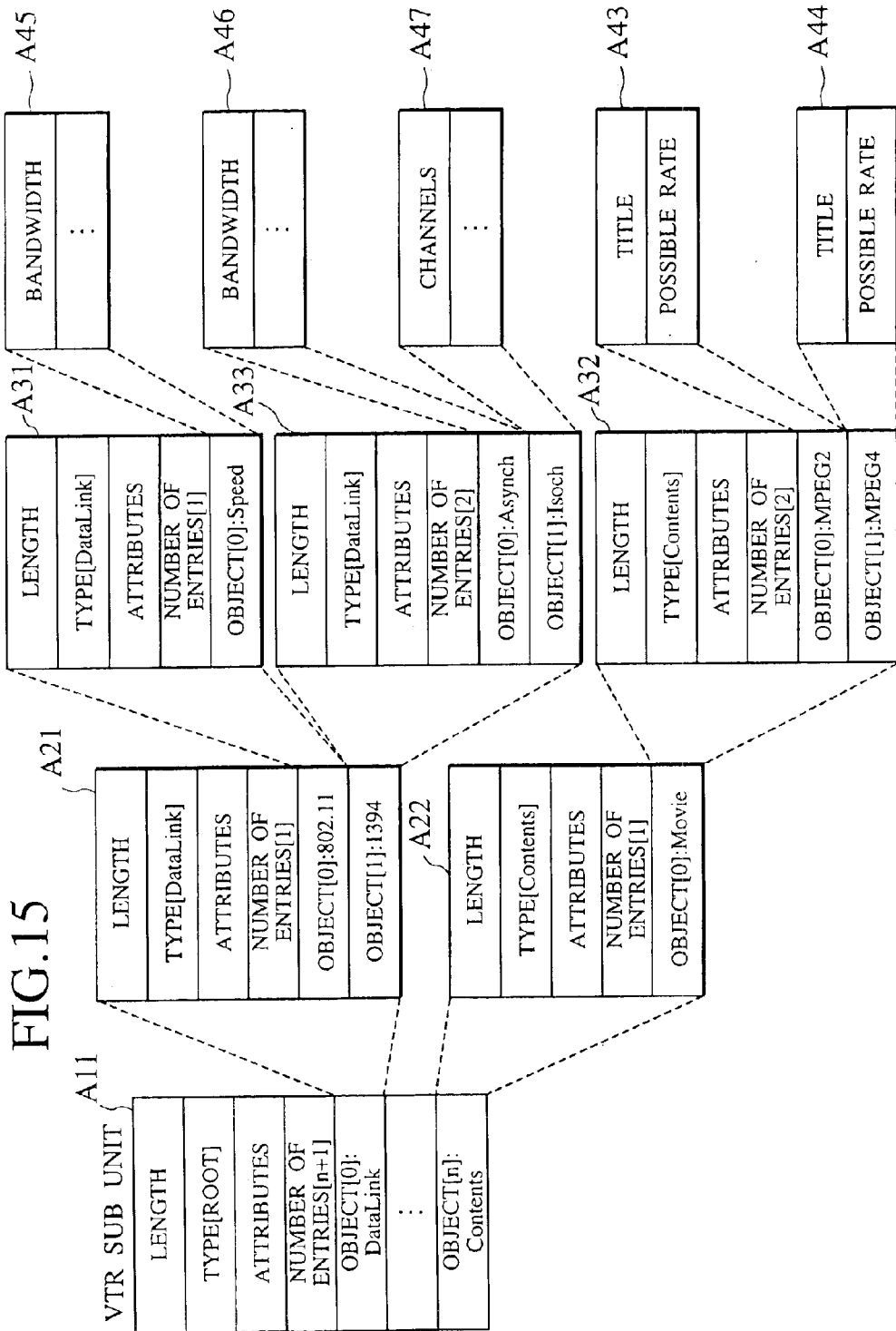
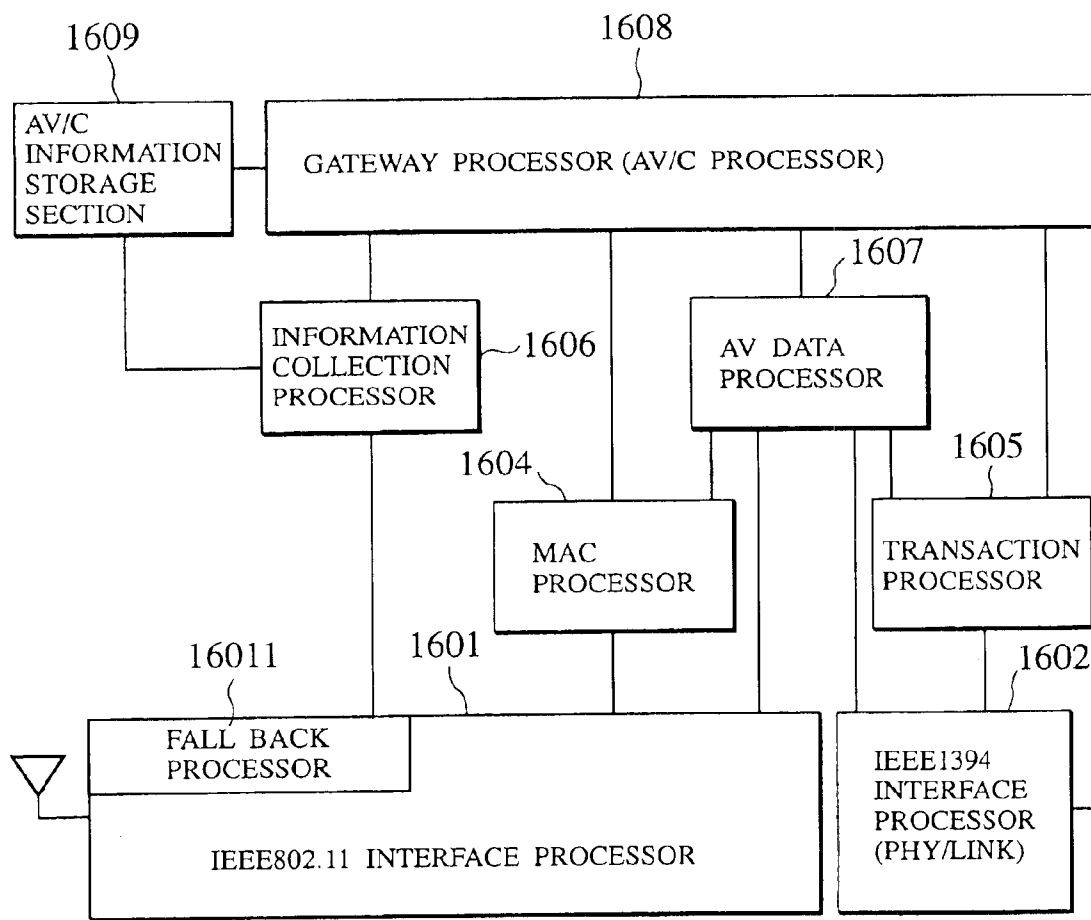

FIG.16



US 6,885,643 B1

1

METHOD AND DEVICE FOR FACILITATING EFFICIENT DATA TRANSFER VIA A WIRELESS COMMUNICATION NETWORK

BACKGROUND OF THE INVENTION

1. Field of the Invention

The present invention relates to a wireless terminal device, a gateway device, and a wireless data transfer control method. In particular, it relates to technology in a data communication system which executes an upper application such as an AV (audio/video) protocol as to a wireless network exhibiting dynamic variations in the condition of the wireless link or in an integrated network system encompassing a wireless network and wired network so as to perform efficient transfer of content data.

2. Related Art

With the recent increase in the use of digital equipment, the implementation of networks in the home has gained attention. At present, the IEEE Std 1394 (hereinafter abbreviated IEEE 1394), which was devised as a connecting wired for connection between AV equipment, has gained attention as a home-use network media. The IEEE 1394 is a high-speed bus capable of connection between a plurality of terminals by a daisy chain or star-configured connection, with transfer of broad band data performed at speeds exceeding 100 Mbps. It is possible on a single wired to perform transfer both asynchronous data and isochronous data.

The achievement of high speeds in wireless networks (wireless LANs) is also gaining attention, and wireless LAN products conforming to IEEE Std 802.11 have already appeared and are going through a process of price reduction. Along with advancing speeds and price reductions for such wireless technology, there are active efforts being made to apply this wireless technology in the home network as well. In the US, such industry groups as Home RF and Bluetooth have been established, and great advances are expected in the future.

A high-speed, low-cost wireless network is thought to be highly acceptable for use in the home network. For this reason, a system that combines a high-speed, low-cost wireless LAN and the IEEE 1394 is expected to form the core of home networks in the future.

However, in an environment in which the IEEE 1394 bus is integrated with a wireless LAN, there are a number of problems.

The first problem is that protocols executed on the IEEE 1394 bus (for example, the AV/C Digital Interface Command Set General Specification, IEEE 1394-1995), were originally developed with the assumption of execution on a wired medium, and did not envision execution in a wireless environment. However, in contrast to a wired network, it is known that there are changes related to the condition of the wireless link (for example, the bandwidth that can be used for transmission). To accommodate such wireless link condition changes, a method (such as fallback) is employed, wherein the wireless transfer speed (or type of modulation to be used) is established, for example, when the wireless LAN is started up, so as to start data communication at transfer speed suited to the wireless link condition. For this reason, when executing an upper layer protocol such as AV/C in a wireless environment, unless the condition of the lower layers is known, a problem can be envisioned such as when a request is made of a lower layer for transfer of content data (such as AV (audiovisual) data) which in reality cannot be transferred.

2

In current wireless LAN specifications (such as Bluetooth), however, there are no functions for “acquiring condition information of the wireless link” or “notify an upper application of the condition of the wireless link.” Additionally, because upper applications on the IEEE 1394 (such as the AV/C Protocol) were devised with the assumption of execution in a wired network, these upper applications also lack an “information element for holding link condition information” and a function for “acquiring link condition information.”

In the case in which AV data is transferred on a medium in which the link condition (such as usable transmission bandwidth) varies, such as in a wireless network, when an upper layer protocol (upper application) such as AV/C is executed, it was not possible to ascertain the condition of the link, which represents a downstream layer. For this reason, it was difficult to select the AV data type and transfer rate usable on the linked to be used and to perform smooth, efficient AV data transfer.

SUMMARY OF THE INVENTION

Accordingly, it is an object of the present invention to provide a wireless terminal device, a gateway device, and a wireless data transfer control method in an environment exhibiting dynamic variations, such as a wireless environment, or an environment in which there is connection between a wired network and a wireless network, which enable efficient data transfer processing, giving consideration to variation in the condition of the wireless link.

A feature of the present invention is that the condition of a dynamically varying wireless link condition information is disclosed to an upper application, and that a determination of whether or not data transfer is possible is made, and the transfer parameters for AV (audio/video) content data being established in accordance with the wireless link condition.

An aspect of the present invention is a terminal device for control of data between communicating entities on a network via a wireless link comprising

- a interface section for performing sending and receiving of packets with a remote communicating entity,
- a link setting section for setting a link for control and for data transfer with the remote communicating entity,
- a wireless link information acquisition section for acquiring wireless link information indicating the condition of a wireless link between said terminal device and a remote communicating entity in the network at the time of setting the link, and for updating the wireless link information acquired at the time of setting the link by the current dynamically acquired wireless link information,
- a wireless link information storage section for storing the above-noted acquired or updated wireless link information, and
- an application section for, based on the wireless link information stored in the wireless link information storage section, for determining whether or not data can be transferred and, if data transfer is possible, optimizing a transfer parameter for transfer of data with the remote communicating entity, in accordance with the wireless link information, this transfer parameter being used to receive data from or send data to the remote communicating entity, via the interface section.

It is possible to use the Descriptor in the SDP Protocol, for example, as a wireless link information storage means.

It is preferable that the wireless link information stored in the wireless link information storage section includes wire-

US 6,885,643 B1

3

less link information with regard to said terminal device and wireless link information with regard to the remote communicating entity.

It is preferable that the wireless link information acquisition section includes

a remote wireless link information requesting section for requesting notification of wireless link information with regard to the remote communicating entity that the remote communicating entity has, at the time of startup by the application section, and

a remote wireless link information receiving section for receiving wireless link information of the remote communicating entity, notification of which is made from the remote communicating entity.

It is preferable that the terminal device further has a wireless link information updating section for changing wireless link information stored in the wireless link information storage section to a format interpretable by the application section and for passing this wireless link information to the application section.

It is preferable that the wireless link storage information section store wireless link information as information relating to a constituent element of said terminal device.

It is preferable that the SubUnit defined in the AV/C Protocol be used as the constituent element.

It is preferable in the present invention further have a wireless link monitoring section for monitoring the condition of a wireless link in the network, for outputting wireless link information acquired by the monitoring to the wireless link information acquisition section. It is possible to use HCI as a wireless link condition monitoring means.

It is preferable that the terminal device further has a local wireless link information sending section for sending wireless link information of said terminal device to the remote communicating entity, in response to a request from the remote communicating entity.

It is preferable that the terminal device further has a user interface section for, based on wireless link information stored in the wireless link information storage section, providing to a user a list of data candidates for transfer, and waiting for input from the user of data selected from the list.

It is preferable that the wireless link information includes at least one of the packet discard rate, the usable bandwidth, the number of usable channels, the usable transfer rate, or observable information on which these are based.

It is preferable that the transfer parameter be at least one of an AV/C command or content data to be transferred.

By doing the above, it is possible for an upper application to consider, for example, a dynamically varying network condition, in making a selection of a type of operation (command) with respect to AV data (content data), and is also possible to make selection of AV data to be accessed from a plurality of AV data.

Another aspect of the present invention is a terminal device for transfer of data between communicating entities over a network via a wireless link, this device having:

an interface section for performing sending and receiving of packets with a remote party,

a link setting section for setting a link for control and for data transfer with the remote communicating entity,

a wireless link information acquisition section for acquiring wireless link information indicating the condition of a wireless link between said terminal device and a remote communicating entity in the network at the time of setting the link, and for updating the wireless link information acquired at the time of setting the link by the current dynamically acquired wireless link information,

4

a wireless link information storage section for storing the above-noted acquired or updated wireless link information, and

a local wireless link information notification section for receiving from the remote communicating entity a request for the local wireless link information of said terminal and for sending the local wireless link information to the remote party.

Another aspect of the present invention is a gateway device for controlling transfer of data between a first terminal device on a wired network and a second terminal device on a wireless network, this gate device comprising,

a first interface section for sending and receiving packets via the wireless network,

a second interface section for sending and receiving packets via the wired network,

a first link setting section for setting a link for control and for data transfer with the second terminal device,

a second link setting section for setting a link data transfer with the first terminal device,

a wireless link information acquisition section for acquiring wireless link information indicating the condition of a wireless link between said terminal device and the second terminal device on the wireless network at the time of setting the link, and for updating the wireless link information acquired at the time of setting the link by the current dynamically acquired wireless link information,

a wireless link information storage section for storing the above-noted acquired or updated wireless link information, and

a network connection processor for, based on wireless link information stored in the wireless link information storage section, performing receiving or sending of data between the first terminal device and the second terminal device via the first interface section and second interface section.

This gateway device further has a proxy means which uses a device on the wired network, or a service or sub-unit on such a device as belonging to said device, disclosing this to the wireless network side. The wireless network is, for example, Bluetooth, IEEE Std 802.11 or the like. The wired network is, for example, the IEEE 1394 bus.

It is preferable that this gateway device further comprises a local wireless link information sending section for, in response to a request from the first terminal device on the wired network or from the second terminal device on the wireless network, sending the local terminal wireless link information to the first terminal device or the second terminal device, respectively.

It is preferable that the wireless link information acquisition section of this gateway device includes

a remote link information requesting section for requesting notification of remote link information of the first terminal device to the first terminal device on the wired network, and

a remote link information receiving section for receiving remote link information, notification of which is made by the first terminal device.

Another aspect of the present invention is a method for controlling transfer of data via a wireless link with a remote communicating entities on a network, this method having

a step of setting a link for control with a remote communicating entity,

a step of acquiring wireless link information indicating the condition of a wireless link between said terminal

US 6,885,643 B1

5

device and a remote communicating entity on the network at the time of setting the link,
 a step of setting a link for data transfer with the remote communicating entity,
 a step of updating wireless link information acquired at the time of setting of the link with current dynamically acquired wireless link information acquired after the setting of the link for data transfer,
 a step of determining whether or not transfer of data is possible, based on the updated wireless link information, and
 a step of optimizing a parameter for transfer of data with the remote communicating entity, in accordance with the wireless link information in the case in which data transfer is possible and performing receiving or sending of data with the remote communicating entity, using the optimized parameter for transfer.

It is preferable in this control method that the wireless link information include wireless link information with regard to said terminal device and information with regard the remote communicating entity.

It is preferable in this control method that the wireless link information updating step includes a step of requesting notification of remote link information of the remote communicating entity to the remote communicating entity at the time of the startup by an application, and a step of receiving wireless link information of the remote communicating entity, notification of which is made by the remote communicating entity.

Another aspect of the present invention is a method for transfer of data via a wireless link with a remote communicating entity on a network, this method having

a step of setting a link for control with the remote communicating entity,
 a step of acquiring wireless link information indicating the condition of a wireless link between said terminal device and the remote communicating entity on the network at the time of setting the link,
 a step of setting a link for data transfer with the remote communicating entity,
 a step of updating the wireless link information acquired at the time of setting of the link with current dynamically acquired wireless link information acquired after the setting of the link, and
 a step of receiving a notification request sent from the remote communicating party for said terminal device wireless link information of said terminal device, and sending wireless link information of said terminal device to the remote communicating entity in response to this request.

Another aspect of the present invention is a method of controlling transfer of data between a first terminal device on a wired network and a second terminal device on a wireless network, this method having

a step of setting a link for control with the second terminal device,
 a step of acquiring, at the time of setting of the link, wireless link information indicating the condition of a wireless link between said terminal device and the second terminal device on the wireless network,
 a step of setting a link for data transfer with the second terminal device,
 a step of updating the wireless link information acquired at the time of setting the link with current dynamically acquired wireless link information acquired after the setting of the link for data transfer,

6

a step of setting a link with the first terminal device, and a step of performing receiving or sending of data between the first terminal device and the second terminal device, based on the wireless link information.

Other features and advantages of the present invention will become apparent from the following descriptions, taken in conjunction with the accompanying drawings.

BRIEF DESCRIPTION OF THE DRAWING

The accompanying drawings, which are incorporated in and constitute a part of the specification, illustrate presently preferred embodiments of the present invention, and together with the general description given above and the detailed description of the preferred embodiments given below, serve to explain the principles of the present invention.

FIG. 1 is a block diagram showing an example a home-use wireless AV network system using a terminal device according to a first embodiment of the present invention;

FIG. 2 is a drawing showing an example of a protocol stack within a wireless terminal device for the case of performing AV data transfer using Bluetooth;

FIG. 3 is a drawing showing an example of a packet transfer processing sequence between wireless terminals in the first embodiment of the present invention;

FIG. 4 is a drawing showing an example of means for holding wireless link condition information using SDP, in a wireless terminal in the first embodiment of the present invention;

FIG. 5 is a block diagram showing an example of the internal configuration of a wireless terminal in the first embodiment of the present invention;

FIG. 6 is a drawing showing another example of a protocol stack within a wireless terminal according to a second embodiment of the present invention, for the case of performing AV data transfer using Bluetooth;

FIG. 7 is a drawing showing another example of a packet transfer processing sequence between wireless terminals in the second embodiment of the present invention;

FIG. 8 is a drawing showing an example of a method for holding condition information of a wireless link using AC/V in the second embodiment of the present invention;

FIG. 9 is a block diagram showing another example of the internal configuration of a wireless terminal in the second embodiment of the present invention;

FIG. 10 is a drawing showing an example of a home-use AV network system using a gateway device according to a third embodiment of the present invention;

FIG. 11 is a drawing showing an example of a packet transfer processing sequence via the gateway device according to the third embodiment of the present invention;

FIG. 12 is a block diagram showing an example of the internal configuration of a gateway device according to the third embodiment of the present invention;

FIG. 13 is a drawing showing another example of a home-use wireless AV network system using a gateway device according to a fourth embodiment of the present invention;

FIG. 14 is a drawing showing another example of a packet transfer processing sequence via a gateway device according to the fourth embodiment of the present invention;

FIG. 15 is a drawing showing an example of a method for holding wireless link information using AV/C in a gateway device according to the fourth embodiment of the present invention; and

FIG. 16 is a drawing showing another example of the internal configuration of a gateway device according to the fourth embodiment of the present invention.

DETAILED DESCRIPTION OF THE PREFERRED EMBODIMENTS

Preferred embodiments of a wireless terminal device, a gateway device, and a method for data transfer control according to the present invention are described in detail below, with reference being made to relevant accompanying drawings.

First Embodiment

A wireless network system according to the first embodiment of the present invention is described in detail below, with reference made to FIG. 1 to FIG. 5.

In the first embodiment, a wireless terminal performing communication using a wireless LAN such as Bluetooth, for example, has function for obtaining wireless link condition information from a local terminal or collected it from another terminal and storing this information. Additionally, the first embodiment has function for giving notification of or disclosing to an upper application (for example AC/V protocol) wireless link condition information collected by the above-noted information collection function, function for storing this notified information, and function for using this wireless link condition information to control the execution of the upper application. By doing this, it is possible to use the wireless link condition information to control the execution of an upper application.

More specifically, the above-noted "wireless link condition information" includes the type of transfer system (link type) usable, the condition of the transfer system (usable bandwidth and usable number of channels), the packet discard rate, the version information of the wireless link, the electrical power mode, the data compression ratio, the data encoding method, or observable information forming the basis of these types of information on the wireless link.

For example, this wireless link condition information is held as Descriptor information defined in the SDP Protocol of Bluetooth, and Descriptor information defined in the AV/C Protocol, thereby enabling an upper AV application to efficiently execute AV data transfer using this wireless link condition information. If this type of wireless link condition information is held as Descriptor information, because it is possible to access not only wireless link condition information in the local terminal device but also such information from another terminal, it becomes possible to easily execute an AV application with consideration given to this dynamically changing wireless link information.

According to the first embodiment, it is possible to easily achieve data transfer such as transfer of AV data (content data) using a medium such as a wireless environment, in which the link condition constantly changes. Additionally, even in a network environment such as the IEEE 1394, in which a connection is made between a wired network and a wireless network, it is possible to perform AV data transfer while consideration is given to the link condition in the wireless network.

In the description that follows, the assumptions are those of a wireless LAN system having means for collecting service information of each wireless terminal (such as the SDP (Service Discovery Protocol) of Bluetooth), and of the case in which execution of the AV/C Protocol application as an upper application, which is a transfer control method for AV data on the IEEE 1394 bus.

The SDP in Bluetooth assumes, at a terminal in a Bluetooth network, a method of storing information such as

vender types and corresponding service types for each terminal, and an executable protocol stack that can be stored, and a protocol for exchange of this information (service information) between each of the terminals. The assumption is that means for storing this service information is that of a Descriptors defining databases into which hierarchal storage is made of each service. In the SDP, hierarchal service classes are defined, services handled by the SDP being assigned to each class.

FIG. 1 shows an example of the basic configuration for transfer of AV data between wireless terminals (101 and 111) connected by a wireless link.

In this case, Bluetooth will be taken as the example of the wireless link. Therefore, the wireless terminal in this case is a Bluetooth terminal (the BT terminals 101 and 111).

As shown in FIG. 1, the BT terminal 101 has a display function, this display function existing as a Display_SubUnit 102, which is one functional unit (SubUnit) in the AV/C Protocol. In the BT terminal 101, SDP information 103, which is acquired, collected and stored service information or the like on the Bluetooth in accordance with an SDP protocol, which constitutes an information acquiring means.

The BT terminal 111 has a VTR function, and a VTR_SubUnit 112 as a functional element in the AV/C Protocol. There is also an SDP information 113 in accordance with the SDP protocol, which is a collection means for service information and the like in Bluetooth.

This AV/C Protocol recognizes each node in terms of Units, and recognizes constituent elements within each node (such as the Display of the BT terminal 101 and the VTR of the BT terminal 111) as sub-units. In the transfer protocol for AV/C control commands (for example, commands such as "play", "stop" and "fast forward"), the sending of a command and the receiving of the response thereto are treated as one set.

Because the BT terminal 101 and the BT terminal 111 are connected by means of a wireless link (Bluetooth), at what rate AV data existing within the VTR_SubUnit of the BT terminal 111 can be transferred to the BT terminal 101 is established by the condition of the wireless link. Specifically, this transfer rate is established by (1) what type of link is used to transfer AV data (for example, ACL (Asynchronous Connectionless) or SCO (Synchronous Connection-Oriented)) on the wireless link (Bluetooth) and (2) the condition of the wireless link, such as how much noise there is on the wireless link (this noise condition affecting the rate at which data can be transferred). For this reason, in the case in which an AV application at upper layer executes AV data transfer via a wireless link such as Bluetooth, it is necessary for the AV application to obtain the condition information of Bluetooth via some means such as the SDP and to execute a data transfer related protocol such as the AV/C Protocol based on this condition information.

FIG. 2 shows an example of a protocol stacking BT terminal having a function that collects and stores condition information with regard to a wireless link.

In FIG. 2, an L2CAP processor 22 that executes a data link layer specification (L2CAP) using an ACL transfer mode 211 of Baseband processor resides on a Baseband processor 21, which is the physical layer specification of Bluetooth. An Audio 27 executing processing such as processing for voice telephone resides as an upper protocol that uses the SCO transfer mode 212 of the Baseband processing. Additionally, an AV/C protocol 23 is defined, along with AV data protocol such as an Audio 25 and Video 24 and the like, as an upstream protocol using the above-noted L2CAP processor 22.

US 6,885,643 B1

9

Additionally, an SDP protocol **26** is defined in a parallel position with these upper protocols. In the first embodiment, the example shown is that in which an AV application **28** is executed while using these upper protocols. While protocols in addition to the above, such as the RFCOMM protocol, are defined in Bluetooth, these are omitted, since they are not directly related to the first embodiment. In the drawing, reference numeral **30** denotes a transport protocol such as an adaptation layer protocol **30** (for example, RTP (Realtime Transport Protocol)).

Because the BT terminals **101** and **111** have the protocol configurations shown in FIG. 2, in the case in which the AV application **28** is executed and AV data sending and receiving processing is performed between the BT terminal **101** and the BT terminal **111**, the AV application **28** acquires wireless link condition information via the SDP protocol **26** and executes the AV/C Protocol **23** after interpreting this wireless link condition information. In accordance with AV/C commands sent to the AV/C protocol **23**, AV data is transferred via the protocol to the Audio **25** and the Video **24**, for example.

In the current Bluetooth specifications, one specific method of acquiring the above-noted wireless link condition information that can be envisioned is that in which an HCI protocol (Host Controller Interface) defined as a Bluetooth protocol is provided at either the BT terminal **101** or the BT terminal **111**, and a “collect wireless link condition information” command is executed by the API (Application Programming Interface) of this protocol.

FIG. 3 shows an example of the processing sequence in which, in the wireless communication between BT terminals having the hardware configuration shown in FIG. 1, the BT terminal **101** serves as a controller, AV data (that is, data that is stored in the VTR_SubUnit of the BT terminal **111**) being readout via Bluetooth for viewing or the like. The specific sequence is as follows.

(1) BT terminal **101** and BT terminal **111** approach one another and each recognizes that it is in a region enabling communication with the other (processing performed by the Baseband processor **21**) (step **S101**).

(2) A connection is set up between the BT terminal **101** and the BT terminal **111** for the purpose of transfer of an AV/C command therebetween (processing performed by the L2CAP processor **22**) (step **S102**).

(3) The BT terminal **101** and the BT terminal **111** use a protocol (HCI) on the Bluetooth to collect wireless link condition information (in particular, ACL link information) in which processing step (2) caused a change, and use the SDP protocol to store same within a Descriptor. In this case, the SDP information (**103**, **113**) in FIG. 1 corresponds to the Descriptor used in the SDP Protocol (step **S103**). Initialization information with regard to the wireless link condition is stored within the Descriptor, this initialization information being replaceable by the information collected in processing step (3), as appropriate.

(4) The BT terminal **101** uses the SubUnit_Info command of the AV/C Protocol to collect SubUnit information existing in the BT terminal **111**. What is used for this is a logical connection on the L2CAP set at (2) (step **S104**).

(5) The BT terminal **111** makes notification of an AV/C response to the BT terminal **101** to the effect that the VTR_SubUnit **1112** exists as a SubUnit within the local terminal device (step **S105**).

(6) The BT terminal **101** sets a logical connection on Bluetooth for the purpose of receiving AV data from the BT terminal **111** (processing performed by the L2CAP processor **22**).

10

(7) The BT terminal **101** and the BT terminal **111** use a protocol (HCI) on the Bluetooth to collect wireless link condition information (in particular, ACL link information) in which (6) caused a change, and use the SDP protocol to store same within a Descriptor (**103**, **113**) (step **S107**).

(8) An AV application at the BT terminal **101** reads the Descriptor information in the SDP protocol of the local terminal device, and obtains link condition information in Bluetooth (step **S108**).

(9) An AV application at the BT terminal **101**, in order to read the Descriptor information on the SDP protocol of the BT terminal **111**, sends an SDP_Request command to the BT terminal **111** (step **S109**).

(10) The BT terminal **101** gives notification of the Descriptor information in the SDP protocol of the local terminal to the BT terminal **101**. The Descriptor information with regard to which notification is given from the BT terminal **111** is appended as Descriptor information of the SDP protocol of the BT terminal **101** and stored. By doing this, the AV application at the BT terminal **101** acquires link condition information on Bluetooth at the BT terminal **111** side (step **S110**).

(11) An AV application at the BT terminal **101** accesses the wireless link condition information collected by the processing steps (8) to (10), and selects an AV/C command to send to the VTR_SubUnit of the BT terminal **111**. At this point, whether or not AV data transfer can be done, and also the selection of the AV data to be played and the transfer rate are specified with consideration to the wireless link condition information, and other various transfer parameters of processing details and the processing method can be made selectable (step **S111**). Additionally, it is possible for the above selection to be made by the intervention of a user. For example, a GUI can be used to present a list of AV content that can be transferred and viewed, in response to the wireless link condition information, the user being caused to select from this content the desired AV content.

(12) The BT terminal **101** sends an AV/C command (play command) for the purpose of playing back desired AV data, for example, using a transfer parameter established at the processing (11) to the BT terminal **111** (step **S112**). What is used at this point is a logical connection on the L2CAP set at the processing (6).

(13) The BT terminal **111** starts the AV data transfer in response to the Play command (step **S113**). What is used at this point is the logical connection on the L2CAP set at the processing (6).

By performing processing as described above, the AV data transfer at the wireless terminals can be executed according to the wireless link condition thereof.

The Bluetooth link condition information (wireless link condition information) collected in processing steps (3) and (7) of the above processing sequence can be envisioned as being, for example, a type of transfer that can be used on the Bluetooth at this point (for example, ACL or SCO) and conditions of that transfer method (such as bandwidth information or channel information). Notice can also be made of the version information of the Bluetooth (for example, Ver. 1 or Ver. 2) and the operating electrical power mode of the Bluetooth (for example, high-power mode or low-power mode). Additionally, it can be envisioned that notification is given of the data link layer information, such as the number of logical connection settings on the L2CAP. If possible, BT terminal hardware information (for example, wireless processing section function information and version information of the protocol being followed) can also be captured as part of the wireless link condition information. An upper AV

US 6,885,643 B1

11

application, in response to this wireless link condition information, can perform processing such as establishing whether or not data transfer can be done, changing the data transfer rate, or retrying the transfer.

In the processing steps (3) and (7) of the above processing sequence, however, it is not necessarily possible to directly collect such link condition information itself, such as usable transfer type (ACL or SCO) or bandwidth information and mode. The reason for this is that the information that can be collected from the ACI that is defined in the HCI is information that is only recognized within that protocol, and there are cases in which information itself, such as a specific bandwidth is not collected (for example, when the packet discard rate or number of channels being used is collected). For this reason, there are cases in which the SDP protocol 26 or an AV application 28 at the BT terminal 101 must rewrite (convert) the obtained wireless link condition information into information that has meaning to the AV application 28, such as the bandwidth information or Bluetooth mode information, in order to perform processing.

FIG. 4 shows an example of Descriptor information held by the SDP protocol executed in the first embodiment.

As shown in FIG. 4, under a Public Browse Root (S11) that is the origin when searching for Descriptor information in the SDP Protocol, there are service groups such as Entertainment (S21), News (S22), and Reference (S23) and the like. For example, under the Entertainment group (S21), there is coded types of stored new sources.

In the first embodiment, under the Reference group (S23), a BT-Link group (S26) is defined, in which information with regard to the wireless link (Bluetooth) stored. Under the BT-Link group there is an information group with regard to the ACL (S27) and an information group with regard to the SCO (S28). Under the information group with regard to the ACL link (S27), there is coded information such as the usable bandwidth on the ACL link (S31), information of the usable channel numbers (S32), and information with regard to the corresponding QOS (Quality of Service) (S33). Under the information group with regard to the SCO link (S28), there is information with regard to, for example, the number of usable SCO channels (S34). Additionally, although not shown in FIG. 4, in addition to information by the type of transfer, such as ACL or SCO, this Descriptor information can have coded in it as Bluetooth condition information other condition information such as Bluetooth version information or electrical power mode and hardware information.

By using a Descriptor such as described above, it is possible using the SDP protocol 26 to collect BT-Link information of a local BT terminal, or to read out BT-Link information of another BT terminal. Specifically, in the processing steps (3) and (7) of the processing sequence of FIG. 3, information under the information group (S27) with regard to the ACL link of the local BT terminal is collected, and at the processing steps (9) and (10), information of the information group (S27) with regard to the ACL link of the BT terminal 111 is read out.

FIG. 5 shows an example of a block diagram of the internal configuration of a BT terminal 101 used in the first embodiment of the present invention.

The BT terminal 101 in the first embodiment is capable of wireless communication using Bluetooth, and has for this purpose a Bluetooth interface processor 501 that executes physical layer processing.

The Bluetooth interface processor 501 has two types of defined transfer modes, an ACL mode 5011 and an SCO mode 5012. As a data link layer function using the ACL mode 5011, there exists a L2CAP processor 503, and as a

12

data link layer management function, there exists a link monitor processor (LMP) 502. This link monitor processor 502 monitors and collects link condition information of Bluetooth, and gives notification thereof to an SDP processor 504.

At the L2CAP processor 503, there resides an SDP processor 504 for accessing, notification, and response with respect to service information (including wireless link condition information) existing at the BT terminal 101, an AV/C processor 505 for execution of a control protocol for AV data transfer with the BT terminal 111, an AV data processor 506 for execution of AV data transfer with the BT terminal 111, and an SDP information storage section 509 for storage of wireless link condition information. Although in this case the AV data handled by the AV data processor 506 is basically data that is received by transfer via the L2CAP processor 503, it will be understood that the first embodiment is not restricted in this manner, and that there is the case in which audio data from the SCO mode 5012 that handles audio data used in a normal telephone is handled.

At this point, notification of information collected at the Link monitor 502 is made to the SDP processor 504, and link condition information of Bluetooth stored in the SDP information storage section 509 is read out by the AV application processor 508.

When this is done, the wireless link condition information collected at the Link monitor processor 502 is not limited to parameters codable as SDP information. Additionally, the parameters representing wireless link condition information coded in the SDP processor 504 are not necessarily parameter that can be read out by an upper AV application processor 508. Therefore, in the SDP processor 504 a function of performing processing to convert information collected at the link monitor processor 502 to a parameter that is readable by the SDP processor 504 is provided within the SDP processor 504 (this being executed in by the SDP parameter conversion section 504b in FIG. 5), and a function of performing processing to convert information coded within the SDP processor 504 to a parameter that is readable by an AV application processor 508 is provided within the AV application processor 508 (the application parameter conversion section 508b in FIG. 5).

Additionally, the AV application processor 508, based on this wireless link condition information, establishes the processing that the AV/C processor 505 and the AV data processor 506 should perform and gives notification of the same.

Specifically, the AV application processor 508, in response to this wireless link condition information, performs such AV application processing as determining whether or not data transfer is possible, changing the data transfer rate, and re-transmitting data, executing this processing while controlling the SDP processor 504, the AV/C processor 505, and the AV data processor 506. The BT terminal 101 has a display section 507 for displaying video data (or AV data) processed by the AV data processor 506. For example, the display section 507 can display a list of AV data (content) that can be transferred, and the user can be made to select AV data to be transferred from this list.

The BT terminal 111 that transfers AV data, in contrast to the BT terminal 101 that acts as a controller, can be provided with all functions, or can have the AV application processor 508 and display section 507 omitted.

According to the first embodiment of the present invention, in a wireless network in which the condition of a link varies dynamically, it is possible for an upper application to perform AV data transfer while consideration is given to the wireless link condition.

US 6,885,643 B1

13

Second Embodiment

A second embodiment of a wireless network system according to the present invention is described below, with reference made to FIG. 6 to FIG. 9.

The second embodiment is another form of the first embodiment shown in FIG. 1, in which AV data transfer is performed between a BT terminal 101 and a BT terminal 111. In the second embodiment, similar to the case of the first embodiment, because the BT terminal 101 and the BT terminal 111 are connected by Bluetooth, a what transfer rate AV data at the BT terminal 111 can be transferred is established by the link type used in Bluetooth, and the degree of noise on Bluetooth.

In the second embodiment, a method of giving notice of the Bluetooth link condition information to an AV application is not that of using an SDP protocol as is done in the first embodiment, but rather that of giving notification by using an AV/C Protocol used by an AV application.

FIG. 6 shows an example of a protocol stacking BT terminal in the above case.

In FIG. 6, there is no SDP protocol processor 26 which in the first embodiment performs processing for passing wireless link condition information. In its place, there is an LMP (Link Management Protocol) processor 29 that using the ACL mode 211 of a Baseband processor 21, similar to the L2CAP processor 22. This LMP protocol processor 29 collects wireless link condition information. The collected wireless link condition information is converted to a format that can be interpreted by an AV/C Protocol processor 23 defined as a protocol at the L2CAP 22, notification thereof being made to the AV/C Protocol processor 23. In the second embodiment, therefore, when performing sending and receiving of AV data between BT terminals, an AV application 28 can collect wireless link condition information from the AV/C Protocol processor 23.

In the example described below, the notification of the wireless link condition information using the AV/C Protocol processor 23 is described for the case in which the method of using the Descriptor at the AV/C Protocol is that in which the wireless link condition information is appended to part of the Descriptor information. Other methods of giving notification of the wireless link condition information to an upper application using the AV/C Protocol that can be envisioned include the method of writing the wireless link condition information to response information to a command to collect SubUnit information defined as an AV/C Protocol command (SubUnit_Information command), and the method of defining a separate AV/C Protocol command for reading out and giving notification of a wireless link condition.

FIG. 7 shows an example of the processing sequence in the second embodiment, wherein with the hardware configuration shown in FIG. 1, a BT terminal 101 reads out AV data (video data stored within the VTR_SubUnit 112 of the BT terminal 111) for viewing.

The actual steps of the processing sequence are as follows.

(1) BT terminal 101 and BT terminal 111 approach one another and each recognizes that it is in a region enabling communication with the other (processing performed by the Baseband processor 21) (step S701).

(2) A connection is set up between the BT terminal 101 and the BT terminal 111 for the purpose of transfer of an AV/C message therebetween (processing performed by the L2CAP processor 22) (step S702).

(3) The BT terminal 101 and the BT terminal 111 use a protocol (HCI) on the Bluetooth to collect wireless link

14

condition information in which processing step (2) caused a change, and store the same within a Descriptor used in the AV/C Protocol (step S703). In this case, the SDP information (103, 113) in FIG. 1 is replaced by the Descriptor used in the AV/C Protocol.

(4) The BT terminal 101 uses the SubUnit_Info command of the AV/C Protocol to collect SubUnit information existing in the BT terminal 111. What is used for this is a logical connection on the L2CAP set at processing (2) (step S704).

(5) The BT terminal 111 makes notification of an AV/C response to the BT terminal 101 to the effect that the VTR_SubUnit 112 exists as a SubUnit within the local terminal device (step S705).

(6) The BT terminal 101 sets a logical connection on Bluetooth for the purpose of receiving AV data from the BT terminal 111 (processing performed by the L2CAP processor 21) (step S706).

(7) The BT terminal 101 and the BT terminal 111 use a protocol (HCI) on the Bluetooth to collect wireless link condition information in which processing (6) caused a change, and stores the same within a Descriptor used in the AV/C Protocol (step S707). In this case, the SDP information 103 and 113 shown in FIG. 1 is replaced by the Descriptor information in the AV/C Protocol.

(8) An AV application at the BT terminal 101 reads the Descriptor information in the AV/C Protocol of the local terminal device, and obtains link condition information in Bluetooth (step S708).

(9) The BT terminal 101, in order to obtain information with regard to the VTR_SubUnit 112 within the BT terminal 111, sends a Read_Descriptor command (AV/C Protocol command) to the BT terminal 11 for the purpose of reading the Descriptor in the AV/C Protocol (step S709). What is used at this point is the logical connection set at the processing (2).

(10) The BT terminal 111 gives notification of the Descriptor information in the AV/C Protocol of the VTR_SubUnit 112 of the local terminal device to the BT terminal 101 (step S701). When this is done, notification is also made of wireless link condition information (which can include, for example, content information such as the encoding method). The wireless link condition information for which notification is made is appended to the coding of the Descriptor information of AV/C to be stored in the AV/C information storage section 910 shown in FIG. 9. What is used in this notification is the logical connection on the L2CAP set at the processing (2).

(11) The BT terminal 101 reads the link condition information of the received Descriptor, and selects an AV/C command in accordance with these link conditions for the purpose of acquiring content (step S711). Also a selection is made of a transfer method (ACL or SCO) that is required by the AV data and capable of use by the Bluetooth. For example, it is possible to make selection of various processing details and methods, such as selection of AV data to be played and specification of rates, giving consideration to the wireless link condition. Additionally, it is possible for the above selection to be made by the intervention of a user. For example, a GUI can be used to present a list of AV data that can be transferred and viewed, in response to the wireless link condition information, the user being caused to select from this listed content the desired AV content.

(12) The BT terminal 101 transfers the above-noted selected AV/C command to the BT terminal 111 so as to specify AV data, after which it sends an AV data playback command (play command) to the BT terminal 111. What is

US 6,885,643 B1

15

used at this point is a logical connection on the L2CAP set at processing (2).

(13) The BT terminal **111** start the AV data transfer in response to the "play" command. What is used at this point is the logical connection on the L2CAP set at the processing (6).

By performing processing as described above, AV data transfer between wireless terminals can be performed efficiently, in accordance with the associated wireless link condition.

As described above, in addition to the method of reading the Descriptor to collect wireless link condition information on the AV/C protocol, there is the method of notation in the response information to the collection command (SubUnit_Info command) of the SubUnit information at processing (5). It can be envisioned that at processing (9), rather than sending a Read_Descriptor command, a command for the purpose of collecting wireless link condition information (for example, a Read_DataLinkInfo) is defined and then used.

The wireless link condition information about which notification is made at the processing (10) in the above-noted processing sequence, similar to the case of the first embodiment, can be envisioned as including such information as the type of transfer and condition of transfer possible on Bluetooth, Bluetooth version information, or electrical power mode information. At the processing (3) and (7) in the above-noted processing sequence, it is assumed that there is a case in which it is necessary to perform some type of Information conversion so as to adapt the collected wireless link condition information to the representation in the Descriptor of the AV/C Protocol.

At processing (10) of the above-noted processing sequence, although a selection is made of content to be received, in accordance with wireless link condition information (the content information being included in the received Descriptor information), a different method for adapting to the wireless link condition information from that of selecting content. For example, in the case in which the VTR_SubUnit **112** of the BT terminal **111** has a real-time encoder function, it can be envisioned that the encoding rate of the encoder is controlled in accordance with the wireless link condition information. In the case in which the VTR_SubUnit **112** has a plurality of encoding functions (for example, an MPEG2 encoding function and an MPEG4 encoding function), a method can also be envisioned in which a type of encoding function to be executed is selected in accordance with this wireless link condition information, and an encoding method capable of providing a rate that can be used on the wireless link is used to encode and sent AV data within the VTR_SubUnit **112**.

FIG. 8 shows an example of Descriptor information within an AC/V Protocol within a BT terminal **111** of the second embodiment.

FIG. 8 shows the case in which a Descriptor is defined in each SubUnit identifiable by the AV/C Protocol, the Descriptors for each SubUnit being represented hierarchally. In the example shown in FIG. 8, first a DataLink_Descriptor (**A21**) corresponding to a communication interface of the BT terminal **111** and a Contents_Descriptor (**A22**) corresponding to a stored movie or game are indicated as an Object group existing within a Root Descriptor (**A11**) of the VTR_SubUnit **112**. As the Objects, the DataLink_Descriptor (**A21**) has the Bluetooth Object (**A31**) and the Contents_Descriptor (**A22**) has the Movie Object (**A32**). Each Object group (**A31** and **A32**) has the specific parameters indicated such as the bandwidth at which transfer can be performed in

16

the Bluetooth ACL mode (**A41**), information with regard, for example, to the number of channels that can be used in SCO (**A42**), the title of an MPEG2 encoded movie and the usable transfer speed (**A43**), and the title of an MPEG4 encoded movie and the usable transfer speed (**A44**). Although not shown in FIG. 8, in addition to information by the type of transfer, such as ACL or SCO, this Descriptor information can have coded in it as Bluetooth condition information other condition information such as Bluetooth version information or electrical power mode and BT terminal **111** hardware information.

FIG. 9 shows an example of a block diagram of the internal configuration of a BT terminal **101** used in the second embodiment.

The BT terminal **101** of the second embodiment has a Bluetooth interface processor **901**, for executing Bluetooth physical layer processing, an L2CAP processor **903** using an ACL mode **9011** defined in the Bluetooth interface processor **901**, and a link monitor processor (LMP) **902**. The link monitor processor **902** collects Bluetooth link condition information and makes notification of this wireless link condition information to an AV/C processor **905**. At this point, the wireless link condition information collected at the Link monitor processor **902** is not necessarily information that is readable by the AV/C Protocol. For this reason, an information conversion processor **909** exists between the link monitor processor **902** and the AV/C processor **905** for the purpose of converting wireless link condition information collected at the link monitor processor **902** to a format that enables inclusion in the Descriptor information of AV/C protocol.

An AC/V processor **905** that executes the AV/C Protocol and an AV data processor **906** that performs transfer of the actual AV data using the ACL mode **9011** or the SCO mode **9012** remain at the L2CAP processor **903**. The Bluetooth link condition information collected by the link monitor processor **902** and about which notification is made to the AV/C processor **905** is held and stored in an AC/V information storage section **910**, and is read out by the AV application processor **908**. The AV application processor **908**, based on the read-out wireless link condition information, makes a determination and notification of the processing to be performed by the AV/C processor **905** and AV data processor **906**. A display section **907** exists for the display of video data processed by the AV data processor **906**.

According to the second embodiment of the present invention, in a wireless network in which the link condition varies dynamically, it is possible using the Descriptor of the AV/C Protocol to perform optimum AV data transfer, giving consideration to the wireless link condition information.

Third Embodiment

Next, a wireless network system according to a third embodiment of the present invention is described in detail below, with references made to FIG. 10 to FIG. 12. The third embodiment provides a function of performing optimized data transfer in a network configuration formed by the integration of a wireless network and a wired network, in which the wireless link condition information is considered.

FIG. 10 shows an example of the configuration of a network formed by integrating a wireless LAN (Bluetooth) and IEEE 1394, for the case of performing AV data transfer.

In FIG. 10, a 1394 terminal **1001** on the IEEE 1394 bus and a BT terminal **1021** on the Bluetooth perform AV data transfer via a wireless gateway (GW) apparatus **1011** that connects the IEEE 1394 with Bluetooth.

In the third embodiment, the BT terminal **1021** has a display function and a Display_SubUnit **1023** in the AV/C Protocol, and holds the SDP information **1022** for Bluetooth.

US 6,885,643 B1

17

The 1394 terminal **1001** has a VTR function, and holds the VTR_SubUnit **1003** in the AV/C Protocol.

Additionally, the wireless gateway apparatus **1011** that connects the IEEE 1394 and the Bluetooth provides a proxy function for the purpose of connecting the IEEE 1394 bus and the Bluetooth on the AV/C Protocol layer.

Specifically, the wireless gateway apparatus **1011** make the BT terminal **1021** recognize the VTR_SubUnit **1003**, which actually exists within the 1394 terminal **1001**, as if it existed within the local terminal device (in the gateway apparatus **1011**). That is, the BT terminal **1021** recognizes the existence of the VTR_SubUnit **1003** within the wireless gateway apparatus **1011**. By executing this proxy processing the BT terminal **1021**, without being aware of the specific network configuration (the fact that the Bluetooth is actually connected to the IEEE 1394), just executes the AV/C Protocol defined on the Bluetooth, thereby enabling execution of the AV/C Protocol between it and the 1394 terminal **1001** on the IEEE 1394. The wireless gateway apparatus **1011** also holds SDP information **1012** on the Bluetooth.

In the third embodiment as well, similar to the case of the first embodiment, because the BT terminal **1021** and the wireless gateway **1011** are connected by a wireless LAN (Bluetooth), at what transfer speed it is possible to perform AV data transfer between the BT terminal **1021** and the 1394 terminal is dependent upon the link condition of the wireless LAN (Bluetooth). In the third embodiment, a protocol stack (refer to FIG. 2) similar to that of the first embodiment is used to execute an AV application on Bluetooth, the SDP information **1012** on the wireless gateway apparatus **1011** and the SDP information **1022** on the BT terminal **1021** being directly read from the AV application. Therefore, use of an API in the HCI protocol is assumed to be used as means for collecting Bluetooth link condition information in the third embodiment as well.

FIG. 11 shows an example of the processing sequence in the third embodiment, for the case in which the BT terminal **1021**, which serves as a controller, reads out AV data (data stored in the VTR_SubUnit **1003** of the 1394 terminal **1001**) for viewing or the like. The actual processing steps are as follows.

(1) The BT terminal **1021** and wireless gateway apparatus **1011** approach one another and each recognizes that it is in a region enabling communication with the other (processing performed by the Baseband processor **21**) (step **S301**).

(2) A logical connection is set up for the purpose of AV/C message transfer between the BT terminal **1021** and the wireless gateway apparatus **1011** (processing being performed by the L2CAP processor **22**) (step **S302**).

(3) The BT terminal **1021** and the wireless gateway **1011** collect wireless link condition information (Bluetooth condition information) in which processing (2) cause as change, and store same within the SDP information storage sections **1012** and **1022** (Descriptors used by the SDP protocol), respectively (step **S303**).

(4) Before and after the processing (1) through (3), the wireless gateway **1011** uses a SubUnit_Info command of the AV/C Protocol to collect SubUnit information that exists in the 1394 terminal **1001** (step **S304**).

(5) The 1394 terminal **1001** makes notification to the wireless gateway **1011** of the fact that a VTR_SubUnit **1003** exists as a SubUnit in the local terminal device, in the form of an AV/C response (step **S305**).

(6) The BT terminal **1021** uses SubUnit_Info command of the AV/C Protocol to collect SubUnit information existing in the connected wireless gateway apparatus **1011** (step **S306**). What is used at this point is a logical connection on the L2CAP set by processing (2).

18

(7) The wireless gateway **1011** makes notification of the VTR_SubUnit **1003** as a SubUnit existing at the local terminal (actually VTR_SubUnit is a SubUnit existing in the 1394 terminal) to the BT terminal **1021** as a VTR_SubUnit **1013** within the local terminal device (step **S307**). What is used at this time is the logical connection on the L2CAP set at processing (2).

(8) The BT terminal **1021** sets up a logical connection on the L2CAP for the purpose of receiving AV data from the wireless gateway apparatus **1011** (step **S308**), processing being performed by the L2CAP processor **22**.

(9) The wireless gateway apparatus **1011** establishes a connection on the IEEE 1394 bus for the purpose of receiving AV data from the 1394 terminal **1001** (step **S309**) (executes the IEC 61883 Protocol).

(10) The BT terminal **1021** and the wireless gateway apparatus **1011** each use the HCI Protocol to collect wireless link condition information (Bluetooth condition information) in which a change resulted from the above-noted processing (8), and store same into the SDP information **1012** and **1020** (Descriptors used in the SDP Protocol), respectively (step **S310**).

(11) An AV application at the BT terminal **1021** read the SDP Protocol Descriptor information of the local terminal device and obtains the Bluetooth link condition information (step **S311**).

(12) The AV application at the BT terminal **1021** sends an SDP_Request command to the wireless gateway **1011** for the purpose of reading the Descriptor information in the SDP Protocol of the wireless gateway apparatus **1011** (step **S312**).

(13) The wireless gateway apparatus **1011** gives notification to the BT terminal **1021** of the Descriptor information in the SDP Protocol at the local terminal device (step **S313**). The Descriptor information in the SDP Protocol at the local device of which notification is given is added to the coding of the Descriptor information of the SDP Protocol at the BT terminal **1021** and stored in the SDP information storage section (the same as the SDP information storage section **509** of FIG. 5).

(14) The BT terminal **1021** accesses the link condition information collected at processing (12) and selects an AV/C command to be sent to the VTR_SubUnit **1013** of the wireless gateway **1011** (step **S314**). It is possible, for example, to make selectable various processing details and processing methods, such as the selection of AV data to be played back and the rate, giving consideration to the condition of the wireless link. The above-noted selection can be made with the intervention of a user. For example, a GUI can be used to present a list of AV content that can be viewed, and the user can be made to select the desired AV content from the list.

(15) The BT terminal **1021** transfers to the wireless gateway **1011** an AV/C command (play command) for the purpose of playing back desired AV data (step **S315**). What is used at this time is a logical connection on the L2CAP set at processing (2).

(16) The wireless gateway apparatus **1011** transfers the received command (Play command) to the VTR_SubUnit **1003** that is the destination of this command within the 1394 terminal **1001** on the IEEE 1394 bus corresponding to the VTR_SubUnit **1013** (step **S316**).

(17) The VTR_SubUnit **1003** within the 1394 terminal **1001** starts the transfer of AV data (step **S317**). What is used at this time is a connection on the IEEE 1394 bus set at processing (9).

By performing processing in this manner, it is possible to efficiently execute the transfer of AV data across an IEEE

1394 bus and a wireless LAN (Bluetooth), in accordance with the condition of the wireless link, and in doing this, it is possible to use the same type of the Bluetooth link condition information and method of notification to the SDP Protocol of the collected link condition information as described with regard to the first embodiment.

Although it is not shown in the drawing, the Descriptor information in the SDP Protocol held in the wireless gateway **1011** of the third embodiment is the same as the Descriptor information (refer to FIG. 4) in the case of the first embodiment. However, because the wireless gateway apparatus **1011** does not only have a Bluetooth interface, but also has an IEEE 1394 interface, in the AV/C Protocol layer, link information of this IEEE 1394 bus is also stored and accessed.

FIG. 12 shows an example of the block diagram of the internal configuration of a wireless gateway **1011** used in the third embodiment. In the third embodiment, the BT terminal **1021** on the wireless network can be implemented by the same type of wireless terminal device as in the first embodiment shown in FIG. 1 or the second embodiment shown in FIG. 9. Because there is no need to consider a network beyond the wireless gateway apparatus, the 1394 terminal **1001** on the wired network can be the same type of terminal device as used in the conventional art.

The wireless gateway apparatus **1011** of the third embodiment can perform both wireless communication by Bluetooth and wired communication by the IEEE 1394, and performs connection processing between these differing communication interfaces. It is also possible to perform proxy processing that enables execution of an AV/C Protocol that bridges across the IEEE 1394 bus and Bluetooth.

In order to perform this processing, within the wireless gateway **1011** in the third embodiment, there is a Bluetooth interface processor **1201** that executes the Bluetooth physical layer, and an IEEE 1394 interface processor **1202** that executes the physical layer and the link layer of the IEEE 1394.

In the Bluetooth interface processor **1201** there are two types of data transfer modes, an ACL mode **12011** and an SCO mode **12012**. An L2CAP processor **1204** exists as a data link layer function using the ACL mode **12011** and a link monitor processor **1203** exists as a data link layer management function. The link monitor processor **1203** collects Bluetooth link condition information, and makes notification thereof to the SDP processor **1206**. The Bluetooth link condition information collected at the link monitor processor **1203** and of which notification is made to the SDP processor **1206** is held and stored in the SDP information storage section **1209**, and is read out by the gateway function processor (AV/C processor) **1208**.

When this is done, the wireless link condition information collected at the link monitor processor **1203** is not necessarily a parameter that can be coded as SDP information. Additionally, parameters that represent the wireless link condition information coded in the SDP processor **1206** are not necessarily parameters that can be read by the upper gateway processor (AV/C processor) **1208**. Therefore, in this case, for example, a function that performs processing (calculation processing) for conversion of information collected at the link monitor processor **1203** to parameters that can be understood by the SDP processor **1206** can be provided within the SDP processor **1206** (this being executed by the SDP conversion section **1206b** shown in FIG. 12), and a function that performs conversion processing (calculation processing) for conversion of information coded within that SDP processor **1206** to parameters that can

be understood by the gateway function processor **1208** can be provided within the gateway function processor **1208** (this being executed by the gateway conversion section **1208b** shown in FIG. 12).

In the IEEE 1394 interface processor **1202**, there exists a transaction processor **1205** for executing transaction processing for performing data transfer in the asynchronous mode on the IEEE 1394 bus.

At the AV data processor **1207** that executes AV data transfer between Bluetooth and the IEEE 1394 bus, protocol processing is performed, protocol processing with respect to data such as audio data from the SCO mode **12012** at the baseband processing **1201** of Bluetooth and AV data that is sent and received via the L2CAP processor **1204** from the ACL mode **12011**. It is possible to use an isochronous channel or asynchronous packets on the IEEE 1394 bus to execute protocol processing of AV data, and to transfer AV data that bridges across Bluetooth and the IEEE 1394 bus.

Additionally, to enable execution of an AV/C Protocol that bridges across Bluetooth and the IEEE 1394 bus via the wireless gateway apparatus **1011**, there is a gateway function processor **1208**. At this gateway function processor **1208**, in addition to execution of the AV/C Protocol proxy processing, processing such as determining whether or not data transfer is possible, establishing the transfer parameters, and controlling transfer is also performed, in accordance with the wireless link condition information.

According to the third embodiment of the present invention, by using the above-noted wireless gateway apparatus, it is possible to perform AV data transfer and data transfer control that bridges across a wireless LAN such as Bluetooth and the IEEE 1394. It is sufficient that a BT terminal on the wireless network (a wireless terminal) execute data transfer control with respect to the wireless gateway **1011**, and it is not necessary to be aware of the IEEE 1394 protocol beyond the gateway. Without having to make a functional expansion of a conventional terminal device as used in a wired network, it is possible to achieve efficient AV data transfer via a gateway apparatus with respect to a wireless terminal on a wireless network.

Fourth Embodiment

A wireless network system according to the fourth embodiment of the present invention is described in detail below, with references being made to FIG. 13 to FIG. 16.

In the fourth embodiment, the difference with respect to the above embodiments is that it is assumed in this embodiment that a user accesses a 1394 terminal **1301** on the IEEE 1394 bus to view AV data within a wireless terminal **1321** existing on the wireless LAN. Similar to the case of the third embodiment, a wireless gateway apparatus **1311** makes a connection between the wireless LAN and the IEEE 1394 bus. In the fourth embodiment, an assumption made is that of the use of a LAN having a fall-back function (a function which changes the transfer rate in response to the wireless condition when the wireless LAN is started up) such as in IEEE 802.11 as the wireless LAN.

FIG. 13 shows an example of the network configuration for the case in which AV data transfer is performed with a configuration formed by the integration of a wireless LAN (Bluetooth) with an IEEE 1394.

In the fourth embodiment, there is a Display_SubUnit **1303** within the 1394 terminal **1301**, and a VTR_SubUnit **1323** within the wireless terminal **1321**. The wireless gateway apparatus **1311** provides a proxy function for executing an AV/C Protocol that bridges across the IEEE 1394 and the wireless LAN (same function as that of wireless gateway in the third embodiment), and makes the 1394 terminal **1301**

US 6,885,643 B1

21

recognize the VTR_SubUnit **1313** corresponding to the VTR_SubUnit **1323** actually existing in the wireless terminal **1321** as the SubUnit existing in the local terminal device. Additionally, condition information for the wireless link, including the fall-back function information of the wireless LAN is stored in the link information **1312** and **1322** within the wireless gateway **1311** and wireless gateway **1321**, respectively.

In the fourth embodiment, as shown in FIG. **14**, the same type of protocol stack as in the case of the second embodiment (refer to FIG. **6**) is used to execute an AV application on the wireless LAN. However, the Bluetooth physical layer part and the L2CAP processor each correspond to the physical layer part and the MAC layer part of the IEEE 802.11 wireless LAN, respectively. On the IEEE 802.11 wireless LAN as well, a protocol that collects wireless link condition information similar to LMP is separately defined.

FIG. **15** shows an example of the processing sequence for the case in which, in the fourth embodiment, AV data (data stored within the VTR_SubUnit **1323** of the wireless terminal **1321**) is read out from 1394 terminal **1301** and viewed. The actual processing steps are as follows.

(1) The wireless LAN is started, and a modulation system is established so as to achieve a transfer rate commensurate with the condition between the wireless gateway **1311** and the wireless terminal **1321** (step **S401**).

(2) The wireless gateway apparatus **1311**, as a result of fall-back, makes notification of the selected transfer rate and the like to the AV/C Protocol (step **S402**).

(3) The wireless gateway apparatus **1311**, using a SubUnit_Info command of the AV/C Protocol, collects SubUnit information existing in the wireless terminal **1321** (step **S403**).

(4) The wireless terminal **1321** makes notification to the wireless gateway apparatus **1311** of the AV/C response, to the effect that the VTR_SubUnit **1323** exists within the local terminal device, in the form of AV/C response (step **S404**).

(5) The 1394 terminal **1301**, for example, uses the SubUnit_Info command of the AV/C Protocol to collect SubUnit information existing at the wireless gateway apparatus **1311** (step **S405**).

(6) The wireless gateway apparatus **1311** makes notification to the 1394 terminal **1301** of the VTR_SubUnit **1323** actually existing within the wireless terminal **1321** as a SubUnit existing within the local terminal (as the VTR_SubUnit **1311** existing within the local terminal) (step **S406**).

(7) The 1394 terminal **1301**, in order to obtain information with regard to the VTR_SubUnit **1313** within the wireless gateway apparatus **1311**, sends a Read_Descriptor command for reading the associated Descriptor (step **S407**).

(8) The wireless gateway apparatus **1311** makes notification to the 1394 terminal **1301** of the Descriptor information of the VTR_SubUnit within the local terminal (step **S408**). At this time, the fall-back information as well as the content information is notified to the wireless gateway apparatus **1301**.

(9) The 1394 terminal **1301** establishes a connection on the IEEE 1394 bus in order to receive AV data from the wireless gateway apparatus **1311** (and for this purpose executes the IEC 61883 Protocol) (step **S409**).

(10) The wireless gateway apparatus **1311** establishes a communication resource on the wireless LAN for the purpose of receiving AV data from the wireless terminal **1321** (operation in the PCF mode) (step **S410**).

(11) The 1394 terminal **1301**, accessing Descriptor information that received at processing (8), selects an AV/C

22

command to be sent to the VTR_SubUnit **1303** of the wireless gateway apparatus **1311** (step **S411**). Furthermore, immediately before the operation of selecting this AV/C command it is possible to perform the processing of (7) and (8) again with the wireless gateway apparatus, and further for the wireless gateway apparatus **1311** to request notification of Descriptor information from the BT terminal **1321**, so as to obtain the wireless link condition and content information when transmitting data. In the selection of this AV/C command, it is possible to perform selection of the AV data to be played and specification of the rate. Additionally, for example, it is possible to make settings of various processing details and methods, such as the selection of AV data to be played and the transfer rate selectable. It further possible to make the above-noted selections by intervention of a user. For example, a GUI can be used to present a list of AV content that can be transferred and viewed, in accordance with the wireless link condition information, and the user being caused to select from this listed content the desired AV content.

(12) The 1394 terminal **1301** sends an AV/C command (play command), for the purpose of playing back the desired AV data, to the wireless gateway apparatus **1311** (step **S412**).

(13) The wireless gateway apparatus **1311** sends the received command (play command) to the VTR_SubUnit **1323** that is the destination of this command within the wireless terminal **1321** on the wireless LAN corresponding to the VTR_SubUnit **1313** (step **S413**).

(14) The VTR_SubUnit **1323** within the wireless terminal **1321** starts AV data transfer with respect to the 1394 terminal **1301** (step **S414**).

By performing the above processing, it is possible to perform highly efficient AV data transfer that bridges across the IEEE 1394 and a wireless LAN (IEEE 802.11), responsive to the condition of the wireless link therebetween.

FIG. **15** is a drawing showing an example of the Descriptor information within the wireless gateway apparatus **1311** of the fourth embodiment.

The Descriptor information of the fourth embodiment as well, similar to the case of the second embodiment, indicates the case in which the Descriptor is defined for each SubUnit identifiable in the AV/C Protocol.

In the example shown in FIG. **15**, the object group existing within the Root Descriptor (**A11**) of the VTR_SubUnit **1313** shows the DataLink_Descriptor (**A21**) corresponding to the communication interface of the wireless gateway apparatus **1311** and the Contents_Descriptor (**A22**) corresponding to a stored video or game or the like. The individual objects that exist are an object (**A31**) corresponding to the IEEE 802.11 in the DataLink_Descriptor (**A21**) and a movie object (**A32**) in the Contents_Descriptor (**A22**). Each of the object groups (**A31**, **A32**, and **A33**) has specific parameters such as the transfer rate after fall-back on the IEEE 802.11 (**A45**), the usable bandwidth in the asynchronous mode on the IEEE 1394 (**A46**), the number of channels set for the isochronous mode (**A47**), the title of an MPEG2 encoded movie and the usable transfer rate (**A43**), and the title of an MPEG4 encoded movie and the usable transfer rate (**A44**). Although it is not shown in FIG. **15**, this Descriptor information can have coded in it condition information such as the type and version of the installed protocol, the sending electrical power mode, and hardware information of the wireless terminal **1321**.

FIG. **16** is an example of a block diagram of the internal configuration of the wireless gateway apparatus **1311** used in the fourth embodiment.

The wireless gateway apparatus **1311** of the fourth embodiment can perform both wireless communication

US 6,885,643 B1

23

using the IEEE 802.11 and wired communication using IEEE 1394, and executes connection processing between these differing interfaces. Proxy processing to enable execution of the AV/C Protocol that bridges across the IEEE 1394 bus and the IEEE 802.11 is also performed in the wireless gateway apparatus **1311**.

In order to perform this processing, the wireless gateway apparatus **1311** of the fourth embodiment comprises an IEEE 802.11 interface processor **1601**, which executes IEEE 802.11 wireless LAN physical layer processing, and an IEEE 1394 interface processor **1602**, which executes IEEE 1394 bus physical layer processing and link layer processing.

Within the IEEE 802.11 interface processor **1601** there exists a fall-back processor **16011**, which executes fall-back processing at the time of wireless LAN startup, and this fall-back processor **16011** is connected to an information collection processor **1606** that collects transfer rate information resulting from the fall-back processing and send the collected information to an AV/C information storage section **1609** which stores the wireless link condition information.

The IEEE 1394 interface processor **1602** is connected to a transaction processor **1605**, which executes transaction processing for performing data transfer in the asynchronous mode on the IEEE 1394 bus.

There is an AV data processor **1607**, which executes AV data transfer between the MAC processor **1604** executing MAC protocol processing of the IEEE 802.11 or IEEE 802.11 wireless LAN and the IEEE 1394 bus, this performing processing of sending and receiving of AV data from the IEEE 802.11 or the IEEE 1394.

Additionally, there is a gateway function processor **1608** for the purpose of enabling execution of the AV/C Protocol bridging across the IEEE 802.11 wireless LAN and the IEEE 1394, via the wireless gateway apparatus **1311**. At this gateway function processor **1608**, in addition to execution of AV/C Protocol proxy processing and the like, in accordance with wireless link condition information, control is executed of whether or not transfer is possible, the transfer parameters, and AV data transfer.

According to the fourth embodiment, by using the above-described wireless gateway apparatus, it is possible to perform AV data transfer and transfer control thereof that bridges across a wireless LAN such as the IEEE 802.11 and the IEEE 1394 bus.

In the foregoing embodiments, it is possible to have a terminal and gateway apparatus that acquire the topology information and data link information and the like for AV data transfer, that is, wireless link condition information, by the local device only, and alternatively possible either to have this acquisition performed by other (remote) devices only, or by both the local device and other devices. The AV application used as an example of an upper application can execute bi-directional data transfer.

In the foregoing embodiments, although the descriptions were for the case in which an upper application at a data receiving side performed selection of AV processing based on notified Information, it is alternatively possible for the upper application at a data sending side to perform selection of processing based on notified information.

The present invention can be applied to a home network and further to various networks in an office or other environment.

The present invention related to an apparatus can also be implemented as a method, and a method according to the present invention can be implemented as an apparatus.

24

The present invention as it relates to a method or apparatus can further be implemented as a computer-readable recording medium, into which is stored a program for the purpose of execution by a computer the procedures corresponding to the present invention (or for the purpose of having a computer function as a means corresponding to the present invention, or further for the purpose of implementing on a computer a function corresponding to the present invention).

All or part of the above-noted functions can be implemented as hardware, in the form of a personal computer or a PDA (personal digital assistant), an AV equipment, or a communication device such as an access point and a home router, or as software executed on this type of hardware.

The above-described embodiments can be implemented as a computer-readable recording medium, into which is stored a program for the purpose of execution by a computer of a prescribed means (or for the purpose of having a computer function as the prescribed means, or further for the purpose of implementing on a computer a prescribed means). This recording medium can be loaded into a CPU of a computer and executed, thereby achieving the functions of the above-described embodiments.

In summary, according to the present invention, it is possible even in an environment formed by a connection between a wired network and a wireless network, such as between a wireless network environment exhibiting network condition variations and an IEEE 1394 bus, to perform highly efficient data transfer, in accordance with the link condition in the wireless network.

It is to be noted that, besides the embodiments described above, many modifications and variations of the above embodiments may be made without departing from the novel and advantageous features of the present invention. Accordingly, all such modifications and variations are intended to be included within the scope of the appended claims.

What is claimed is:

1. A terminal device for control of data between communicating entities on a network via a wireless link, comprising:

an interface section for performing sending and receiving of packets with a remote communicating entity;

a link setting section for setting a link for control and for data transfer with the remote communicating entity;

a wireless link information acquisition section for acquiring wireless link information indicating the condition of a wireless link between said terminal device the remote communicating entity in the network at the time of setting the link, and for updating the wireless link information acquired at the time of setting the link by the current dynamically acquired wireless link information, the wireless link information including at least transmittable bandwidth information;

a wireless link information storage section for storing the acquired or updated wireless link information as Descriptor information referable by the remote communicating entity; and

an application section for, based on the wireless link information stored in the wireless link information storage section, determining whether or not data can be transferred and, if data transfer is possible, changing a transmission rate for transfer of data with the remote communicating entity, in accordance with the wireless link information.

2. The terminal device according to claim 1, wherein the wireless link information stored in the wireless link infor-

US 6,885,643 B1

25

information storage section includes wireless link information with regard to said terminal device and wireless link information with regard to the remote communicating entity.

3. The terminal device according to claim 2, wherein the wireless link information acquisition section includes:

a remote wireless link information requesting section for requesting notification of wireless link information with regard to the remote communicating entity that the remote communicating entity has, at the time of startup by the application section; and

a remote wireless link information receiving section for receiving wireless link information of the remote communication entity, notification of which is made from the remote communication entity.

4. The terminal device according to claim 1, further comprising:

a wireless link information updating section for changing wireless link information stored in the wireless link information storage section to a format interpretable by the application section and for passing the wireless link information to the application section.

5. The terminal device according to claim 1, wherein the wireless link information storage section stores wireless link information as information related to a constituent element of said terminal device.

6. The terminal device according to claim 5, wherein a SubUnit defined in the AV/C Protocol, upper layer protocol of the IEEE 1394, is used as the constituent element.

7. The terminal device according to claim 1, further comprising:

a wireless link monitoring section for monitoring the condition of a wireless link in the network, for outputting wireless link information acquired by the monitoring to the wireless link information acquisition section.

8. The terminal device according to claim 1, further comprising:

a local wireless link information sending section for sending wireless link information of said terminal device to the remote communicating entity, in response to a request from the remote communicating entity.

9. The terminal device according to claim 1, further comprising:

a user interface section for, based on wireless link information stored in the wireless link information storage section, providing to a user a list of data candidates for transfer, and waiting for input from the user of data selected from the list.

10. The terminal device according to claim 1, wherein the wireless link information includes at least one of a packet discard rate, a usable bandwidth, a number of usable channels, a usable transfer rate, or observable information on which these are based.

11. The terminal device according to claim 1, wherein the transfer parameter is at least one of an AV/C command or content data to be transferred.

12. A terminal device for transfer of data between communicating entities over a network via a wireless link, comprising:

an interface section for performing sending and receiving of packets with a remote communicating entity, and a link setting section for setting a link for control and for data transfer with the remote communicating entity;

a wireless link information acquisition section for acquiring wireless link information indicating a condition of

26

a wireless link between a local terminal device and the remote communicating entity in the network at the time of setting the link, and for updating the wireless link information acquired at the time of setting the link by the current dynamically acquired wireless link information, the wireless link information including at least transmittable bandwidth information;

a wireless link information storage section for storing the acquired or updated wireless link information as Descriptor information referable by the remote communicating entity; and

a local terminal wireless link information notification section for receiving from the remote entity a request for local wireless link information of the local terminal and for sending the local wireless link information to the remote communicating entity.

13. A gateway device for controlling transfer of data between a first terminal device on a wired network and a second terminal device on a wireless network, the gateway device comprising:

a first interface section for sending and receiving packets via the wireless network,

a second interface section for sending and receiving packets via the wired network,

a first link setting section for setting a link for control and for data transfer with the second terminal device;

a second link setting section for setting a link with the first terminal device;

a wireless link information acquisition section for acquiring wireless link information indicating a condition of a wireless link between the gateway device and the second terminal device on the wireless network at the time of setting the link, and for updating the wireless link information acquired at the time of setting the link by the current dynamically acquired wireless link information, the wireless link information including at least transmittable bandwidth information;

a wireless link information storage section for storing the acquired or updated wireless link information as Descriptor information referable by the first and second terminal devices; and

a network connection processor for, based on the wireless link information stored in the wireless link information storage section, performing receiving or sending of data between the first terminal device and the second terminal device via the first interface section and the second interface section.

14. The gateway device according to claim 13, further comprising: a local terminal wireless link information sending section for, in response to a request from the first terminal device on the wired network or from the second terminal device on the wireless network, for sending local wireless link information to the first terminal device or the second terminal device, respectively.

15. The gateway device according to claim 13, wherein the wireless link information acquisition section includes:

a remote link information requesting section for requesting notification of the remote link information of the second terminal device to the first terminal device on the wired network; and

a remote link information receiving section for receiving remote link information, notification of which is made by the first terminal device.

16. A method for controlling transfer of data via a wireless link with a remote communicating entity over a network, comprising:

US 6,885,643 B1

27

setting a link for control with the remote communicating entity;

acquiring wireless link information indicating a condition of a wireless link between a local terminal device and the remote communicating entity at the time of setting the link, the wireless link information including at least transmittable bandwidth information;

setting a link for data transfer with the remote communicating entity;

updating wireless link information acquired at the time of setting of the link with current dynamically acquired wireless link information acquired after the setting of the link for data transfer;

storing the acquired or updated wireless link information as Descriptor information referable by the remote communicating entity;

determining whether or not transfer of data is possible, based on the updated wireless link information; and

changing a transmission rate for transfer of data with the remote communicating entity, in accordance with wireless link information in the case in which data transfer is possible, and performing receiving or sending of content data with the remote communicating entity, using the changed transmission rate.

17. The method according to claim 16, wherein the wireless link information includes wireless link information with regard to the local terminal device and information with regard the remote communicating entity.

18. The method according to claim 17, wherein the wireless link information updating includes:

requesting notification of the remote wireless link information of the remote communicating entity at the time of the startup of an application; and

receiving wireless link information of the remote communicating entity, notification of which is made by the remote communicating entity.

19. A method for transfer of content data via a wireless link with a remote communicating party on a network, comprising:

setting a link for control with the remote communicating entity;

acquiring wireless link information indicating a condition of a wireless link between a local terminal device and the remote communicating entity on the network at the time of setting the link, the wireless link information including at least transmittable bandwidth information;

setting a link for data transfer with the remote communicating entity;

updating the wireless link information acquired at the time of setting of the link with current dynamically acquired wireless link information acquired after the setting of the link;

storing the acquired or updated wireless link information as Descriptor information referable by the remote communicating entity; and

receiving a notification request sent from the remote communicating entity for the local wireless link information of the local terminal device, and sending to the remote communicating entity wireless link information of the local terminal device in response to the request.

20. A method for transfer of content data between a first terminal device on a wired network and a second terminal device on a wireless network, this method comprising:

28

setting a link for control with the second terminal device; acquiring, at the time of setting of the link, wireless link information indicating a condition of a wireless link between the first terminal device and the second terminal device on the wireless network, the wireless link information including at least transmittable bandwidth information;

setting a link for data transfer with the second terminal device;

updating the wireless link information acquired at the time of setting the link with current dynamically acquired wireless link information acquired after the setting of the link;

setting a link with the first terminal device;

storing the acquired or updated wireless link information as Descriptor information referable by the first and second terminal devices; and

performing receiving or sending of data between the first terminal device and the second terminal device, based on the wireless link information.

21. A terminal device for control of data between communicating entities on a network via a wireless link, comprising:

an interface section for performing sending and receiving of packets with a remote communicating entity;

a link setting section for setting a link for control and for data transfer with the remote communicating entity;

a wireless link information acquisition section for acquiring wireless link information indicating the condition of a wireless link between said terminal device and the remote communicating entity in the network at the time of setting the link, and for updating the wireless link information acquired at the time of setting the link by the current dynamically acquired wireless link information;

a wireless link information storage section for storing the acquired or updated wireless link information; and

an application section for, based on the wireless link information stored in the wireless link information storage section, determining whether or not data can be transferred and, if data transfer is possible, optimizing a transfer parameter for transfer of data with the remote communicating entity, in accordance with the wireless link information, this transfer parameter being used to receive data from or send data to the remote communicating entity, via the interface section, wherein

the wireless link information stored in the wireless link information storage section includes wireless link information with regard to the terminal device and wireless link information with regard to the remote communicating entity, and

the wireless link information acquisition section includes:

a remote wireless link information requesting section for requesting notification of wireless link information with regard to the remote communicating entity that the remote communicating entity has, at the time of startup of the application; and

a remote wireless link information receiving section for receiving wireless link information of the remote communicating entity, notification of which is made from the remote communicating entity.

22. A gateway device for controlling transfer of data between a first terminal device on a wired network and a second terminal device on a wireless network, the gateway device comprising:

US 6,885,643 B1

29

a first interface section for sending and receiving packets via the wireless network,

a second interface section for sending and receiving packets via the wired network,

a first link setting section for setting a link for control and for data transfer with the second terminal device;

a second link setting section for setting a link with the first terminal device;

a wireless link information acquisition section for acquiring wireless link information indicating a condition of a wireless link between the gateway device and the second terminal device on the wireless network at the time of setting the link, and for updating the wireless link information acquired at the time of setting the link by the current dynamically acquired wireless link information;

a wireless link information storage section for storing the acquired or updated wireless link information; and

a network connection processor for, based on the wireless link information stored in the wireless link information storage section, performing receiving or sending of data between the first terminal device and the second terminal device via the first interface section and the second interface section, wherein

the wireless link information acquisition section includes:

a remote link information requesting section for requesting notification of the remote link information of the second terminal device to the first terminal device on the wired network; and

a remote link information receiving section for receiving remote link information, notification of which is made by the first terminal device.

23. A method for controlling transfer of data via a wireless link with a remote communicating entity over a network, comprising:

30

setting a link for control with the remote communicating entity;

acquiring wireless link information indicating a condition of a wireless link between a local terminal device and the remote communicating entity at the time of setting the link;

setting a link for data transfer with the remote communicating entity;

updating wireless link information acquired at the time of setting of the link with current dynamically acquired wireless link information acquired after the setting of the link for data transfer;

determining whether or not transfer of data is possible, based on the updated wireless link information; and

optimizing a parameter for transfer of data with the remote communicating entity, in accordance with wireless link information in the case in which data transfer is possible, and performing receiving or sending of content data with the remote communicating entity, using the optimized parameter for transfer, wherein

the wireless link information includes wireless link information with regard to the local terminal device and information with regard to the remote communicating entity, and the wireless link information updating includes:

requesting notification of the remote wireless link information of the remote communicating entity at the time of the startup of an application; and

receiving wireless link information of the remote communicating entity, notification of which is made by the remote communicating entity.

* * * * *

EXHIBIT 2

TP-Link WiFi Routers (using 802.11 Wi-Fi)

IEEE Std 802.11™-2012
(Revision of
IEEE Std 802.11-2007)

IEEE Standard for Information technology—
Telecommunications and information exchange between systems
Local and metropolitan area networks—
Specific requirements

Part 11: Wireless LAN Medium Access Control (MAC) and Physical Layer (PHY) Specifications

Sponsor
LAN/MAN Standards Committee
of the
IEEE Computer Society



1. A terminal device for control of data between communicating entities on a network via a wireless link, comprising:
 - an interface section for performing sending and receiving of packets with a remote communicating entity;
 - a link setting section for setting a link for control and for data transfer with the remote communicating entity;
 - a wireless link information acquisition section for acquiring wireless link information indicating the condition of a wireless link between said terminal device the remote communicating entity in the network at the time of setting the link, and for updating the wireless link information acquired at the time of setting the link by the current dynamically acquired wireless link information, the wireless link information including at least transmittable bandwidth information;
 - a wireless link information storage section for storing the acquired or updated wireless link information as Descriptor information referable by the remote communicating entity; and
 - an application section for, based on the wireless link information stored in the wireless link information storage section, determining whether or not data can be transferred and, if data transfer is possible, changing a transmission rate for transfer of data with the remote communicating entity, in accordance with the wireless link information.

Claim 1	
<p>A terminal device for control of data between communicating entities on a network via a wireless link, comprising:</p>	<p>Source: https://www.tp-link.com/us/home-networking/wifi-router/archer-c7/</p>  <p>The image shows a black TP-Link Archer C7 AC1750 wireless router. It has a sleek, rectangular design with three black antennas protruding from the top. The front panel features a row of seven green LED status lights and the model number 'AC1750' printed on the right side. The router is centered within a red dashed rectangular border.</p>

Claim 1	
<p>A terminal device for control of data between communicating entities on a network via a wireless link, comprising:</p>	<p>Source: https://www.tp-link.com/us/home-networking/wifi-router/archer-c7/</p> <p>AC1750 Wireless Dual Band Gigabit Router</p> <p>Archer C7 V5 ▾</p> <ul style="list-style-type: none">• Supports 802.11ac standard - 3 times faster than wireless N speeds*• Simultaneous 2.4GHz 450 Mbps and 5GHz 1300 Mbps connections for 1.75Gbps of total available bandwidth• USB Port - easily shares files & media with networked devices or remotely via FTP server• Guest Network Access - provides secure Wi-Fi access for guests sharing your home or office network• Easy setup and management with Tether App

Claim 1

A terminal device for control of data between communicating entities on a network via a wireless link, comprising:

Source: IEEE Std 802.11™-2012: Part 11: Wireless LAN Medium Access Control (MAC) and Physical Layer (PHY) Specifications

PART 11: WIRELESS LAN MAC AND PHY SPECIFICATIONS

IEEE
Std 802.11-2012

Figure 4-11 combines the components from previous figures with both types of services to show the complete IEEE 802.11 architecture.

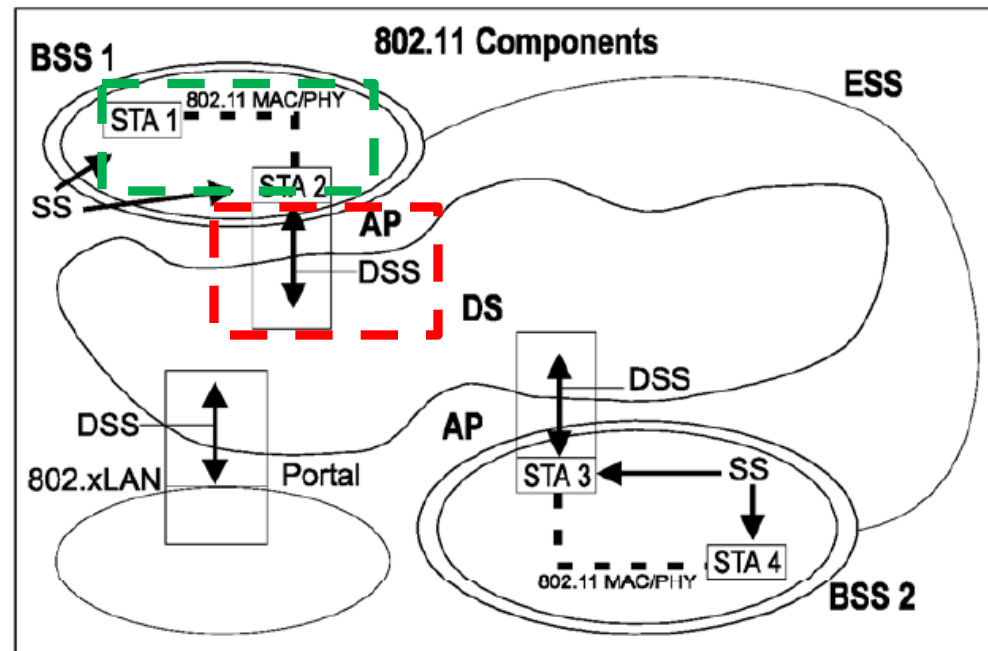

Figure 4-11—Complete IEEE 802.11 architecture

Claim 1

a link setting
section for setting
a link for control
and for data
transfer with the
remote
communicating
entity;

Source: <https://www.clearToSend.net/cts-047-troubleshooting-wifi-wireshark/>

No.	Time	Source	Destination	Length	Info
1	07:11:58.066	d8:bb:2c:1b:4f:05	ff:ff:ff:ff:ff:ff	151	Probe Request, SN=891, FN=0, Flags=.....C, SSID=TEST
2	07:11:58.067	0c:68:03:d6:88:78	d8:bb:2c:1b:4f:05	263	Probe Response, SN=2134, FN=0, Flags=...R...C, BI=102,

▶ Frame 1: 151 bytes on wire (1208 bits), 151 bytes captured (1208 bits)

▼ Radiotap Header v0, Length 25

- Header revision: 0
- Header pad: 0
- Header length: 25
- ▶ Present flags
- MAC timestamp: 909104562
- ▶ Flags: 0x12
- Data Rate: 6.0 Mb/s
- Channel frequency: 5240 [A 48]
- ▶ Channel flags: 0x0140, Orthogonal Frequency-Division Multiplexing (OFDM), 5 GHz spectrum
- SSI Signal: -40 dBm
- SSI Noise: -95 dBm
- Antenna: 1

▶ 802.11 radio information

▼ IEEE 802.11 Probe Request, Flags:C

- Type/Subtype: Probe Request (0x0004)
- ▶ Frame Control Field: 0x4000
- .000 0000 0000 0000 = Duration: 0 microseconds
- Receiver address: ff:ff:ff:ff:ff:ff
- Destination address: ff:ff:ff:ff:ff:ff
- Transmitter address: d8:bb:2c:1b:4f:05
- Source address: d8:bb:2c:1b:4f:05
- BSS Id: ff:ff:ff:ff:ff:ff
- 0000 = Fragment number: 0
- 0011 0111 1011 = Sequence number: 891
- ▶ Frame check sequence: 0x6528f9cd [correct]

▼ IEEE 802.11 wireless LAN management frame

▼ Tagged parameters (98 bytes)

- ▶ Tag: SSID parameter set: TEST
- ▶ Tag: Supported Rates 6, 9, 12, 18, 24, 36, 48, 54, [Mbit/sec]
- ▶ Tag: HT Capabilities (802.11n D1.10)
- ▶ Tag: Extended Capabilities (8 octets)
- ▶ Tag: Interworking
- ▶ Tag: VHT Capabilities (IEEE Std 802.11ac/D3.1)
- ▶ Tag: Vendor Specific: 00:50:f2: Unknown 8
- ▶ Tag: Vendor Specific: 00:10:18

Claim 1

a wireless link
 information acquisition
 section for acquiring
 wireless link
 information indicating
 the condition of a
 wireless link between
 said terminal device
 the remote
 communicating entity
 in the network

Source: IEEE Std 802.11™-2012: Part 11: Wireless LAN Medium Access Control (MAC) and Physical Layer (PHY) Specifications (also in IEEE Std 802-11-2016 “ax”)

IEEE Std 802.11-2012 LOCAL AND METROPOLITAN AREA NETWORKS—SPECIFIC REQUIREMENTS

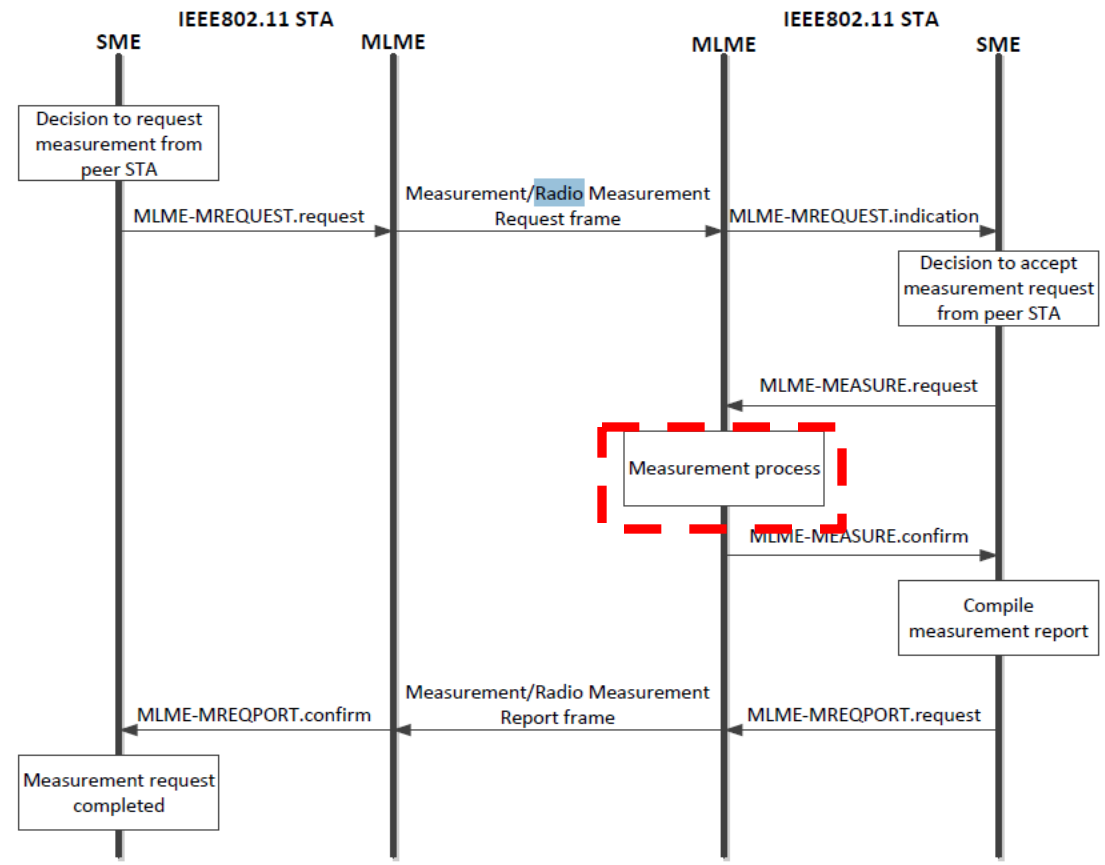

Figure 6-3—Measurement request—accepted

Claim 1

at the time of
setting the link,

Source: <https://www.clearToSend.net/cts-047-troubleshooting-wifi-wireshark/>

No.	Time	Source	Destination	Length	Info
1	07:11:58.066	d8:bb:2c:1b:4f:05	ff:ff:ff:ff:ff:ff	151	Probe Request, SN=891, FN=0, Flags=.....C, SSID=TEST
2	07:11:58.067	0c:68:03:d6:88:78	d8:bb:2c:1b:4f:05	263	Probe Response, SN=2134, FN=0, Flags=...R...C, BI=102,

▶ Frame 1: 151 bytes on wire (1208 bits), 151 bytes captured (1208 bits)

▼ Radiotap Header v0, Length 25

- Header revision: 0
- Header pad: 0
- Header length: 25
- ▶ Present flags
- MAC timestamp: 909104562
- ▶ Flags: 0x12
- Data Rate: 6.0 Mb/s
- Channel frequency: 5240 [A 48]
- ▶ Channel flags: 0x0140, Orthogonal Frequency-Division Multiplexing (OFDM), 5 GHz spectrum
- SSI Signal: -40 dBm
- SSI Noise: -95 dBm
- Antenna: 1

▶ 802.11 Radio Information

▼ IEEE 802.11 Probe Request, Flags:C

- Type/Subtype: Probe Request (0x0004)
- ▶ Frame Control Field: 0x4000
- .000 0000 0000 0000 = Duration: 0 microseconds
- Receiver address: ff:ff:ff:ff:ff:ff
- Destination address: ff:ff:ff:ff:ff:ff
- Transmitter address: d8:bb:2c:1b:4f:05
- Source address: d8:bb:2c:1b:4f:05
- BSS Id: ff:ff:ff:ff:ff:ff
- 0000 = Fragment number: 0
- 0011 0111 1011 = Sequence number: 891
- ▶ Frame check sequence: 0x6528f9cd [correct]

▼ IEEE 802.11 wireless LAN management frame

▼ Tagged parameters (98 bytes)

- ▶ Tag: SSID parameter set: TEST
- ▶ Tag: Supported Rates 6, 9, 12, 18, 24, 36, 48, 54, [Mbit/sec]
- ▶ Tag: HT Capabilities (802.11n D1.10)
- ▶ Tag: Extended Capabilities (8 octets)
- ▶ Tag: Interworking
- ▶ Tag: VHT Capabilities (IEEE Std 802.11ac/D3.1)
- ▶ Tag: Vendor Specific: 00:50:f2: Unknown 8
- ▶ Tag: Vendor Specific: 00:10:18

Claim 1

and for updating the wireless link information acquired at the time of setting the link by the current dynamically acquired wireless link information,

Source: IEEE Std 802.11™-2012: Part 11: Wireless LAN Medium Access Control (MAC) and Physical Layer (PHY) Specifications (also in IEEE Std 802-11-2016 “ax’)

Table 6-7—ESS Link Parameter Set

Name	Type	Valid range	Description
PeakOperationalRate	Integer	As defined in 8.4.2.3	The integer representing the desired peak modulation data rate used for data frame transmission.
MinimumOperationalRate	Integer	As defined in 8.4.2.3	The integer encoding of the desired minimum modulation data rate used in data frame transmission.
NetworkDowntimeInterval	Integer	0 – 65 535	Desired advance warning time interval, in TUs, for MSGCF-ESS-Link-Going-Down events.
DataFrameRSSI	Integer	-100 to 40	The received signal strength in dBm of received Data frames from the network. This may be time-averaged over recent history by a vendor-specific smoothing function.
BeaconRSSI	Integer	-100 to 40	The received signal strength in dBm of Beacon frames received on the channel. This may be time-averaged over recent history by a vendor-specific smoothing function.
BeaconSNR	Integer	0–100	The signal to noise ratio of the received data frames, in dB. This may be time-averaged over recent history by a vendor-specific smoothing function.
DataFrameSNR	Integer	0–100	The signal to noise ratio of the received Beacon frames, in dB. This may be time-averaged over recent history by a vendor-specific smoothing function.
DataThroughput	Integer	0 – 65 535	The data throughput in megabits per second, rounded to the nearest megabit. This may be time-averaged over recent history by a vendor-specific smoothing function.

Claim 1

the wireless link information including at least transmittable bandwidth information;

Source: IEEE Std 802.11™-2012: Part 11: Wireless LAN Medium Access Control (MAC) and Physical Layer (PHY) Specifications

Table 6-7—ESS Link Parameter Set

Name	Type	Valid range	Description
PeakOperationalRate	Integer	As defined in 8.4.2.3	The integer representing the desired peak modulation data rate used for data frame transmission.
MinimumOperationalRate	Integer	As defined in 8.4.2.3	The integer encoding of the desired minimum modulation data rate used in data frame transmission.
NetworkDowntimeInterval	Integer	0 – 65 535	Desired advance warning time interval, in TUs, for MSGCF-ESS-Link-Going-Down events.
DataFrameRSSI	Integer	-100 to 40	The received signal strength in dBm of received Data frames from the network. This may be time-averaged over recent history by a vendor-specific smoothing function.
BeaconRSSI	Integer	-100 to 40	The received signal strength in dBm of Beacon frames received on the channel. This may be time-averaged over recent history by a vendor-specific smoothing function.
BeaconSNR	Integer	0–100	The signal to noise ratio of the received data frames, in dB. This may be time-averaged over recent history by a vendor-specific smoothing function.
DataFrameSNR	Integer	0–100	The signal to noise ratio of the received Beacon frames, in dB. This may be time-averaged over recent history by a vendor-specific smoothing function.
DataThroughput	Integer	0 – 65 535	The data throughput in megabits per second, rounded to the nearest megabit. This may be time-averaged over recent history by a vendor-specific smoothing function.

Claim 1

a wireless link information storage section for storing the acquired or updated wireless link information as Descriptor information referable by the remote communicating entity; and

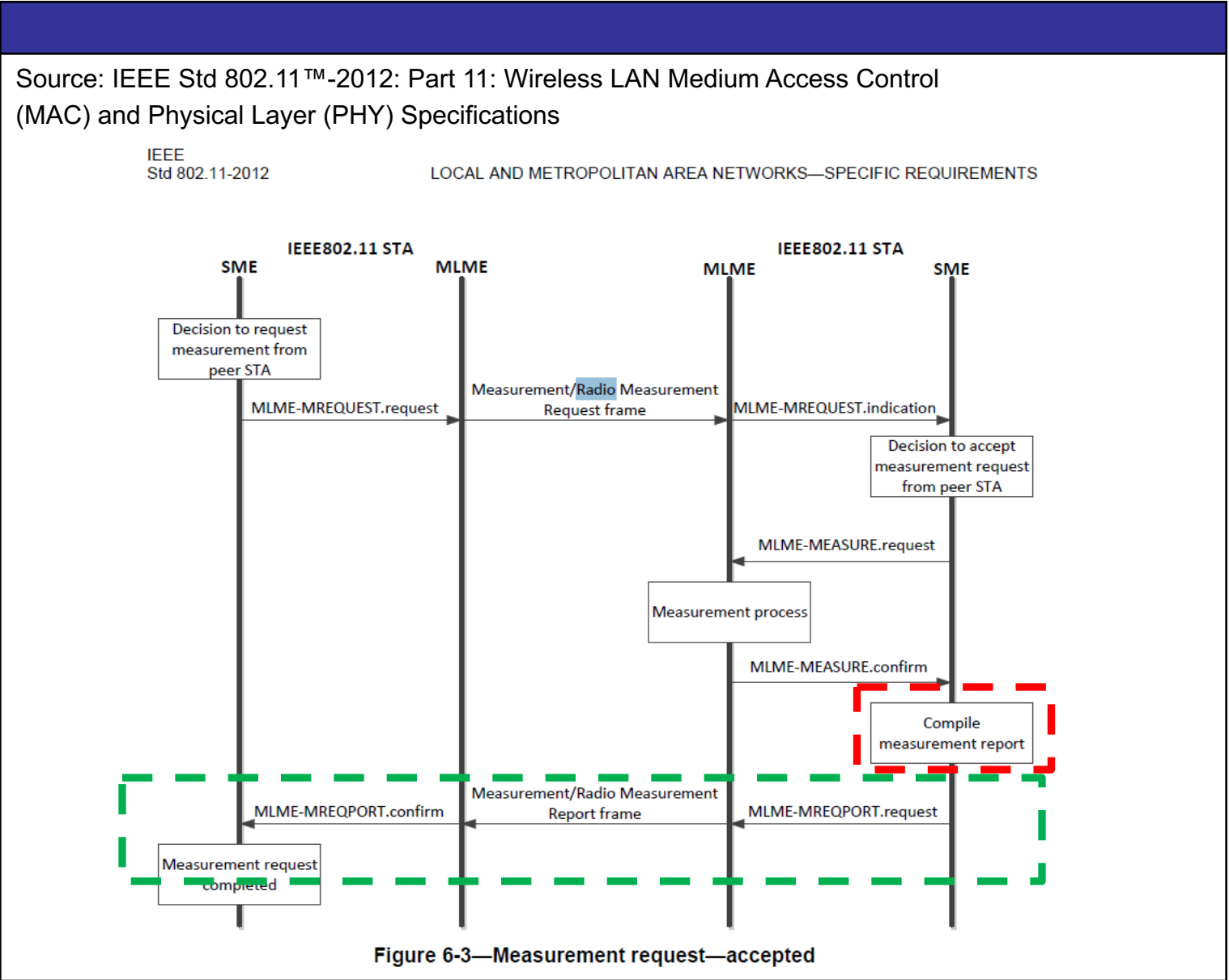

Claim 1

an application section for, based on the wireless link information stored in the wireless link information storage section, determining whether or not data can be transferred

Source: <https://www.microcontrollertips.com/teardown-inside-tp-link-archer-c7-wireless-router/>

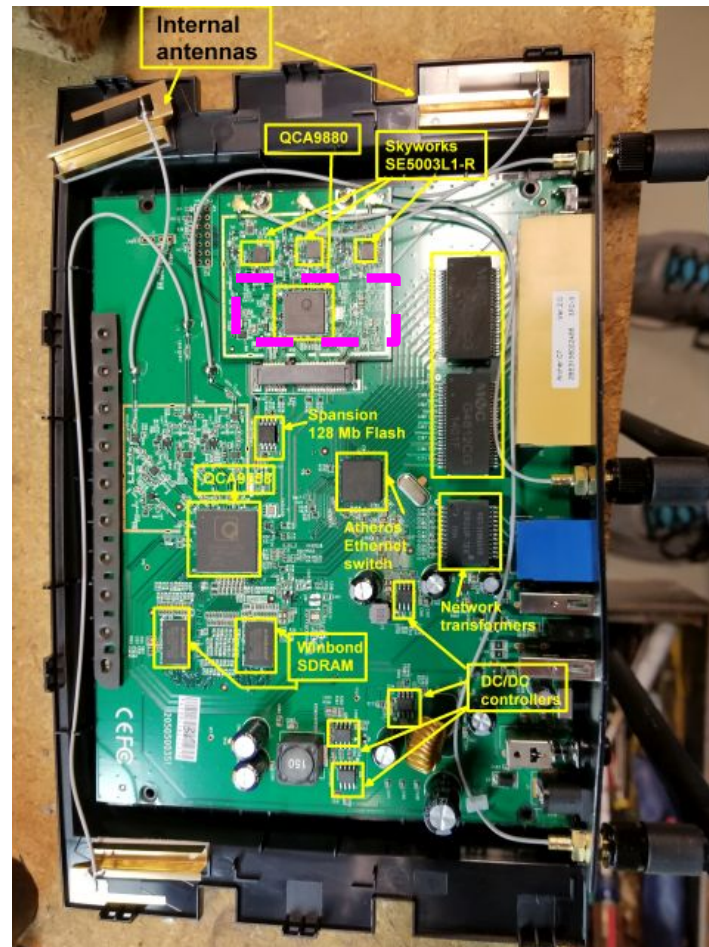

Claim 1

an application section for, based on the wireless link information stored in the wireless link information storage section, determining whether or not data can be transferred

Source: <http://www.revolutionwifi.net/revolutionwifi/2014/09/wi-fi-snr-to-mcs-data-rate-mapping.html>
 (Cached): https://drive.google.com/open?id=1TBUzWUG758_HJLcH1sjLeNjDgjtX50hP

MCS is "Modulation and Coding Scheme"

MCS Value Achieved by Clients at Various Signal to Noise Ratio Levels (SNR)

Protocol	Channel	1	2	3	4	5	6	7	8	9	10		
802.11b	20MHz	None	None	None	MCS 0	MCS 0	MCS 0	MCS 1	MCS 1	MCS 1	MCS 1	Modulation Key	
802.11a/g	20MHz	None	MCS 0	MCS 0	MCS 1	MCS 2	MCS 2	MCS 2	MCS 2	MCS 3	MCS 3		None = Grey
802.11n	20MHz	None	MCS 0	MCS 0	MCS 0	MCS 1	MCS 1	MCS 1	MCS 1	MCS 2	MCS 2		BPSK = Red
802.11n	40MHz	None	None	None	None	MCS 0	MCS 0	MCS 0	MCS 1	MCS 1	MCS 1		QPSK = Orange
802.11ac	20MHz	None	MCS 0	MCS 0	MCS 0	MCS 1	MCS 1	MCS 1	MCS 1	MCS 2	MCS 2		16-QAM = Yellow
802.11ac	40MHz	None	None	None	None	MCS 0	MCS 0	MCS 0	MCS 1	MCS 1	MCS 1		64-QAM = Blue
802.11ac	80MHz	None	None	None	None	None	None	None	MCS 0	MCS 0	MCS 0		256-QAM = Green
802.11ac	160MHz	None	None	None	None	None	None	None	None	None	None		
	SNR in dB	11	12	13	14	15	16	17	18	19	20		
802.11b	20MHz	MCS 2	MCS 2	MCS 2	MCS 2	MCS 2	MCS 3	MCS 3	MCS 3	MCS 3	MCS 3		802.11 Type Key
802.11a/g	20MHz	MCS 4	MCS 4	MCS 4	MCS 4	MCS 5	MCS 5	MCS 5	MCS 6	MCS 6	MCS 7	802.11b	
802.11n	20MHz	MCS 3	MCS 3	MCS 3	MCS 3	MCS 4	MCS 4	MCS 4	MCS 5	MCS 5	MCS 6	802.11ag	
802.11n	40MHz	MCS 1	MCS 2	MCS 2	MCS 3	MCS 3	MCS 3	MCS 3	MCS 4	MCS 4	MCS 4	802.11n	
802.11ac	20MHz	MCS 3	MCS 3	MCS 3	MCS 3	MCS 4	MCS 4	MCS 4	MCS 5	MCS 5	MCS 6	802.11ac	
802.11ac	40MHz	MCS 1	MCS 2	MCS 2	MCS 3	MCS 3	MCS 3	MCS 3	MCS 4	MCS 4	MCS 4		
802.11ac	80MHz	MCS 1	MCS 1	MCS 1	MCS 1	MCS 2	MCS 2	MCS 3	MCS 3	MCS 3	MCS 3		
802.11ac	160MHz	MCS 0	MCS 0	MCS 0	MCS 1	MCS 1	MCS 1	MCS 1	MCS 2	MCS 2	MCS 3		

Claim 1

if data transfer is possible, changing a transmission rate for transfer of data with the remote communicating entity, in accordance with the wireless link information.

Source: <http://www.revolutionwifi.net/revolutionwifi/2014/09/wi-fi-snr-to-mcs-data-rate-mapping.html>
 (Cached): https://drive.google.com/open?id=1TBUzWUG758_HJLcH1sjLeNjDgjtX50hP

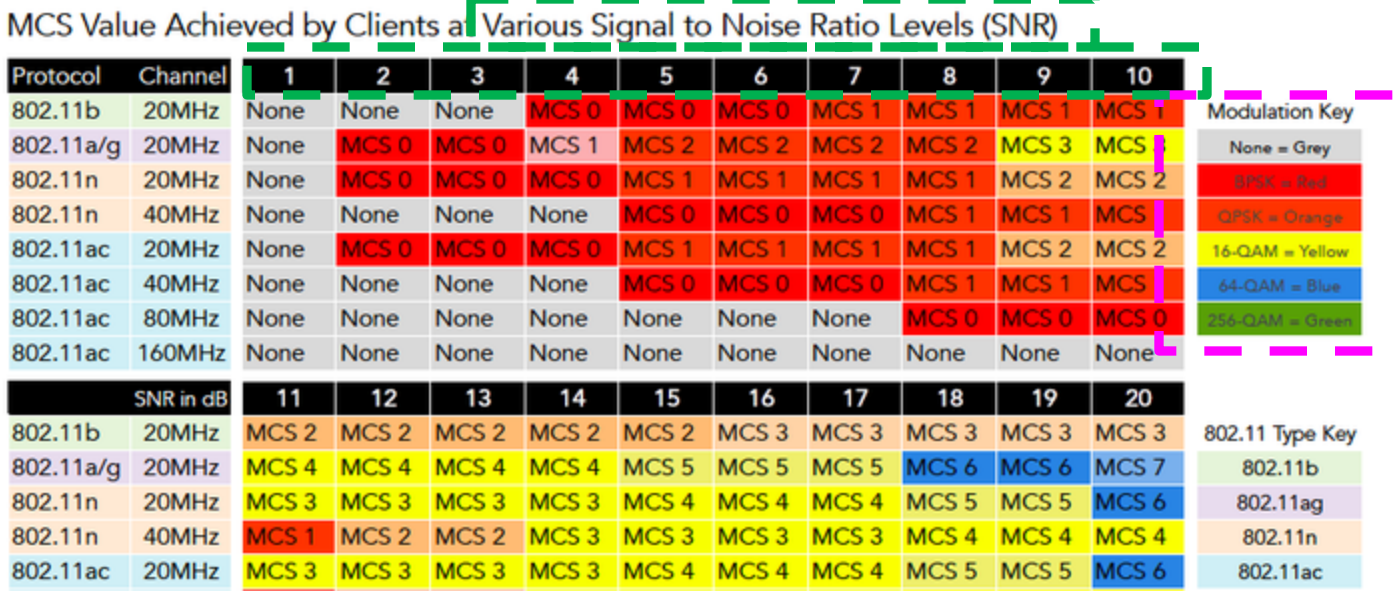

Table 9-5—Non-HT reference rate

Modulation	Coding rate (R)	Non-HT reference rate (Mb/s)
BPSK	1/2	6
BPSK	3/4	9
QPSK	1/2	12
QPSK	3/4	18
16-QAM	1/2	24

Source: IEEE Std 802.11™-2012: Part 11: Wireless LAN Medium Access Control (MAC) and Physical Layer (PHY) Specifications

EXHIBIT 3

(12) **United States Patent**
Yoshizawa

(10) **Patent No.:** US 6,928,166 B2
 (45) **Date of Patent:** Aug. 9, 2005

(54) **RADIO COMMUNICATION DEVICE AND USER AUTHENTICATION METHOD FOR USE THEREWITH**

(75) Inventor: **Junichi Yoshizawa, Ome (JP)**

(73) Assignee: **Kabushiki Kaisha Toshiba, Kawasaki (JP)**

(*) Notice: Subject to any disclaimer, the term of this patent is extended or adjusted under 35 U.S.C. 154(b) by 887 days.

(21) Appl. No.: **09/795,355**

(22) Filed: **Mar. 1, 2001**

(65) **Prior Publication Data**

US 2001/0036273 A1 Nov. 1, 2001

(30) **Foreign Application Priority Data**

Apr. 28, 2000 (JP) 2000-131861

(51) **Int. Cl.⁷** **H04K 1/00; H04L 9/16**

(52) **U.S. Cl.** **380/247; 380/255; 713/168**

(58) **Field of Search** **380/247, 270, 380/255; 713/168, 169, 171, 201**

(56) **References Cited**

U.S. PATENT DOCUMENTS

5,442,805 A 8/1995 Sagers et al.
 6,748,195 B1 * 6/2004 Phillips 455/41.2
 6,766,160 B1 * 7/2004 Lemilainen et al. 455/411
 2002/0132605 A1 * 9/2002 Smeets et al. 455/411
 2004/0128509 A1 * 7/2004 Gehrman 713/171

FOREIGN PATENT DOCUMENTS

EP WO 97/26769 7/1997
 EP WO 01/74011 A1 10/2001
 GB 2350971 A * 12/2000 G06F/1/00
 JP 09-233223 9/1997
 JP 2872996 1/1999

OTHER PUBLICATIONS

Johannes Elg, "Specification of the Bluetooth System," ver. 1.0 B, pp. 186-199, Nov. 29, 1999.

English abstract of JP 11-275661 published Oct. 8, 1999.

* cited by examiner

Primary Examiner—Matthew Smithers

(74) *Attorney, Agent, or Firm*—Finnegan, Henderson, Farabow, Garrett & Dunner, L.L.P.

(57) **ABSTRACT**

To allow flexible security level switching according communication situations, a password holding section holds a plurality of device authentication passwords, for example, a temporary password and a private password. The temporary password is valid only under a certain situation and the private password has a high level of confidentiality to increase the device security. A password management section allows the user to add a new password to the password holding section and delete an existing password therefrom. A password selecting section selects the most suitable password for current connection from among passwords in the password holding section according to a user event, information acquired by an external factor acquisition section, and information from a time control section. The selected password is output to a password checking section.

19 Claims, 5 Drawing Sheets

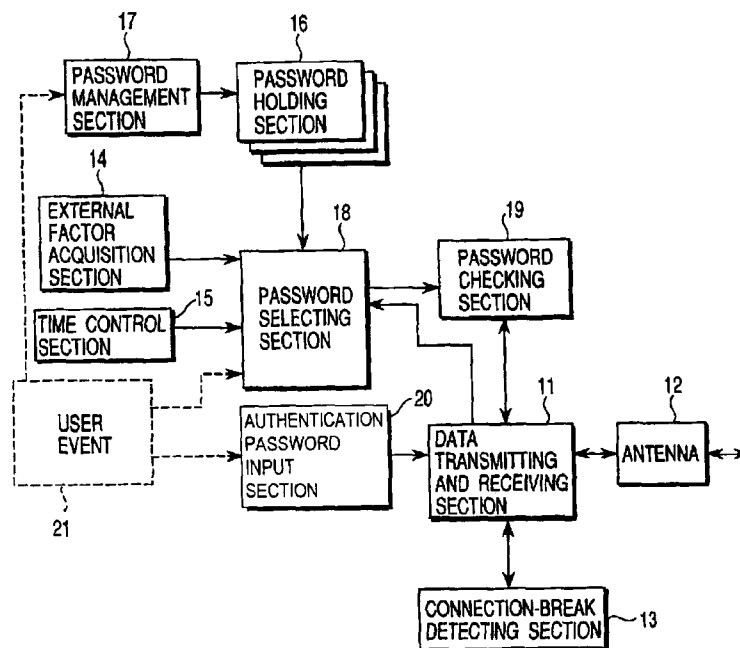

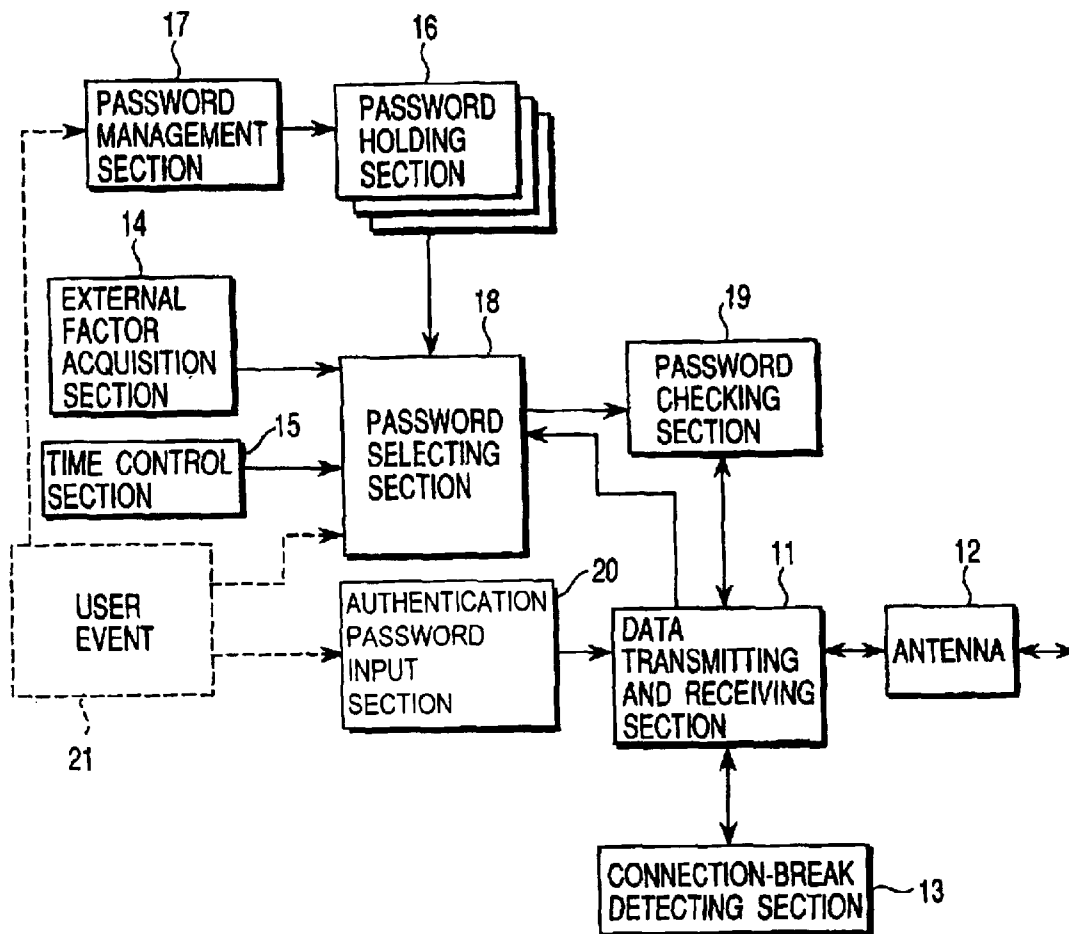
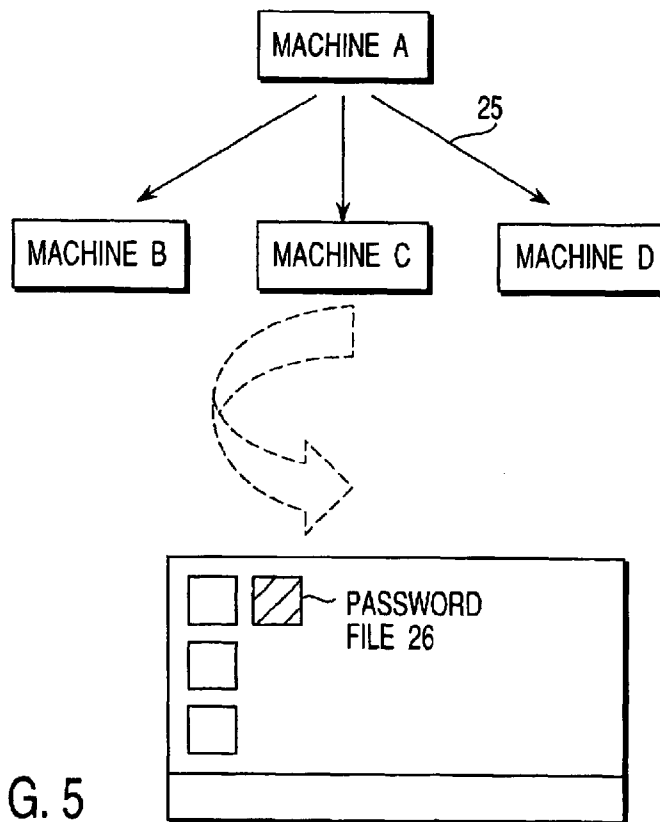
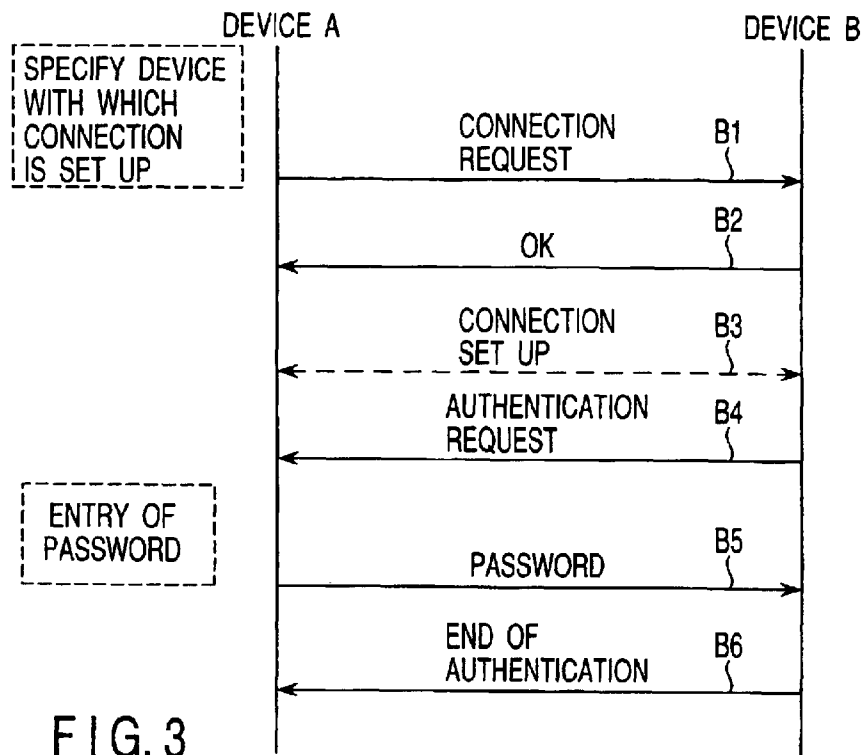

FIG. 1



FIG. 2



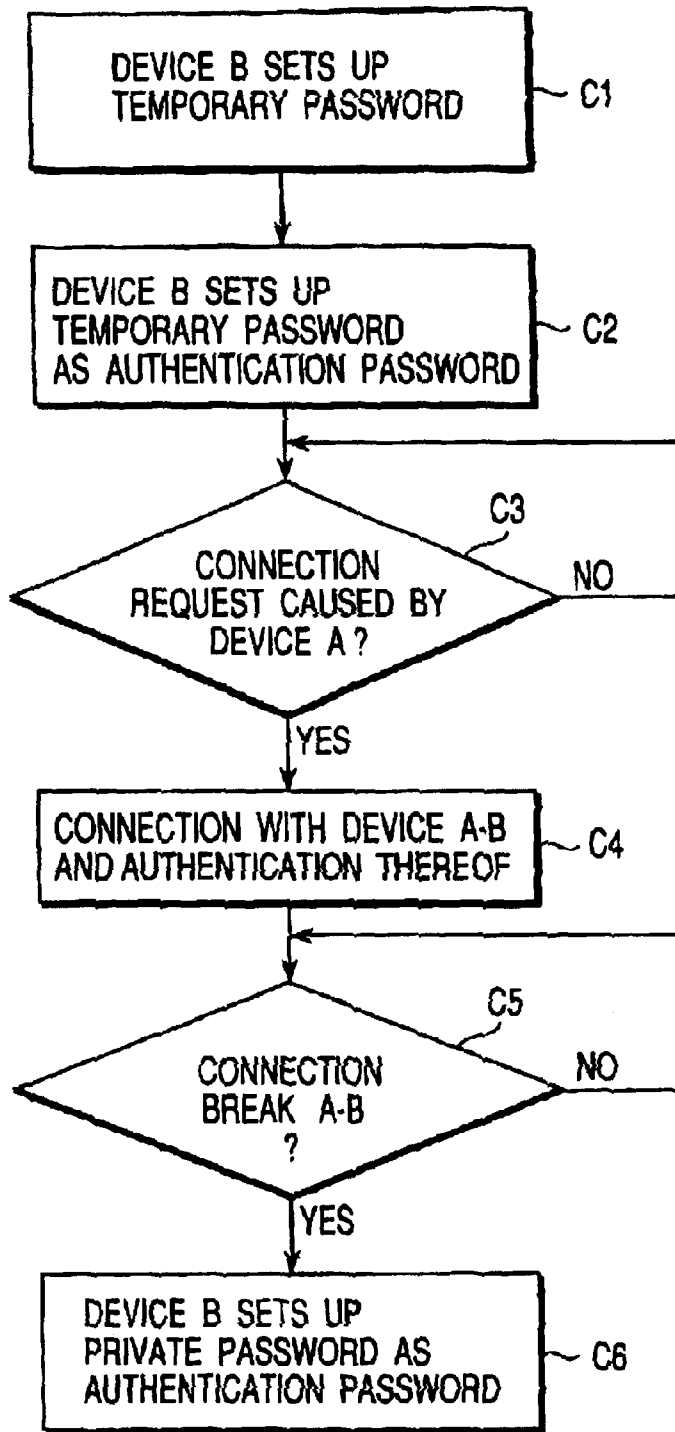

FIG. 4

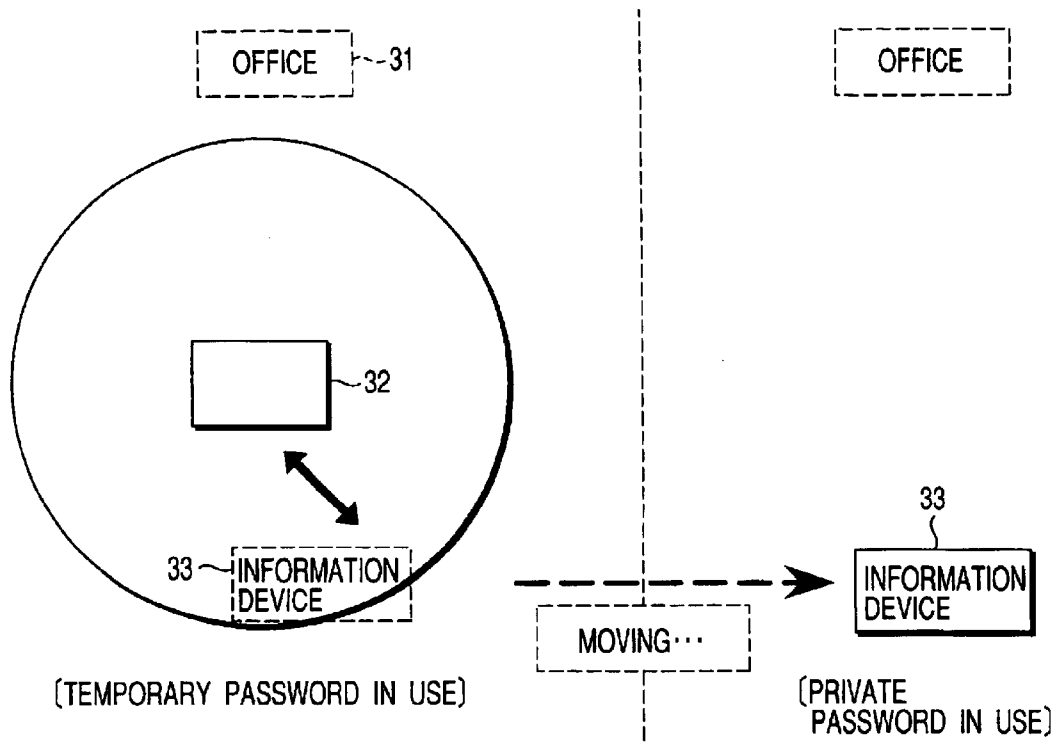

FIG. 6

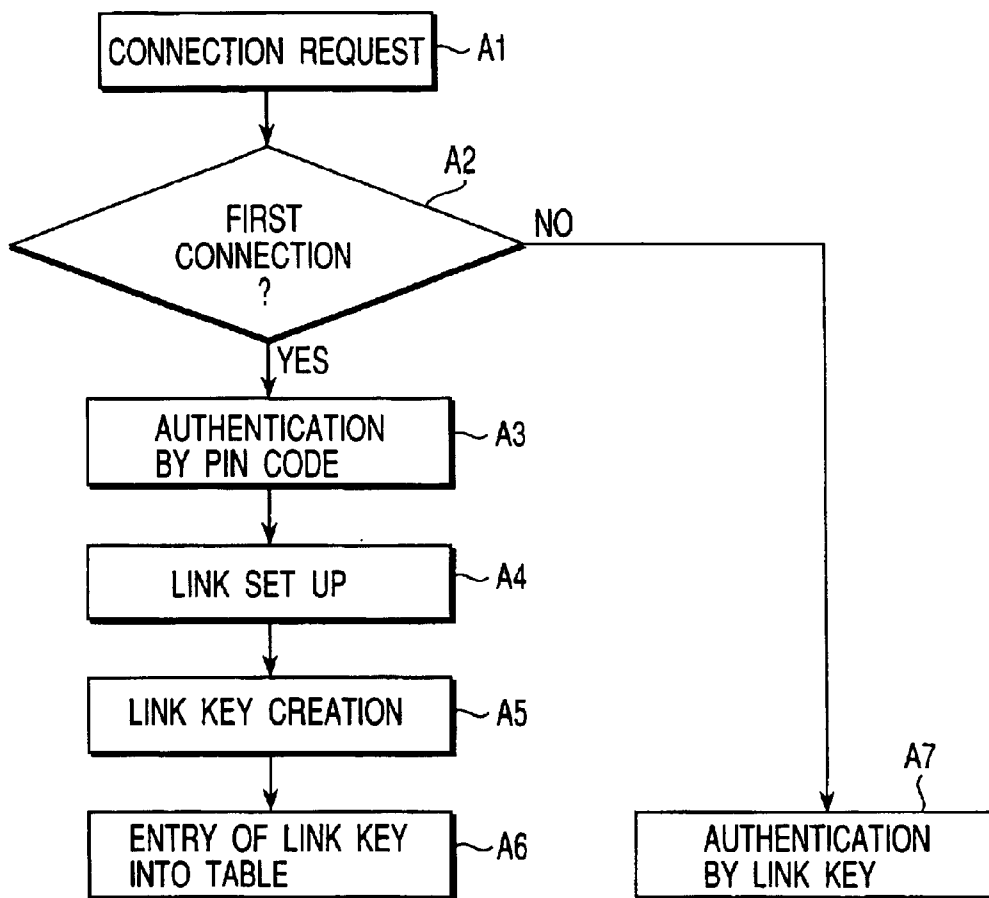

FIG. 7 (PRIOR ART)

UNIQUE ADDRESS (Hex)	LINK KEY
A36B35	*****
4B3346	*****
.....

FIG. 8 (PRIOR ART)

US 6,928,166 B2

1

RADIO COMMUNICATION DEVICE AND USER AUTHENTICATION METHOD FOR USE THEREWITH

CROSS-REFERENCE TO RELATED APPLICATIONS

This application is based upon and claims the benefit of priority from the prior Japanese Patent Application No. 2000-131861, filed Apr. 28, 2000, the entire contents of which are incorporated herein by reference.

BACKGROUND OF THE INVENTION

The present invention relates to a radio communication device and a user authentication method using user authentication passwords.

In recent years, attention has been paid to radio communication systems adapted for personal areas, such as IrDA, Bluetooth, HomeRF, etc. Particularly, Bluetooth and HomeRF have merits of no directivity and high transparency over infrared communication systems, such as IrDA, and are greatly expected to develop and find wide application in the future. The Bluetooth is short-haul radio communication standards and establishes radio communications within 10 m or 100 m using the ISM (Industrial Science Medical) band of 2.4 GHz band. The Bluetooth adopts frequency-hopping spectrum-spreading techniques and allows for connection of up to eight devices through the use of time-division multiplexing techniques.

In addition to allowance for simultaneous connection of multiple devices, the radio communication systems, such as Bluetooth, HomeRF, etc., make a great feature of a relatively long transmission distance of, say, 10 to 100 m in comparison with the infrared communication systems, such as IrDA. This provides an advantage of ease of handling, but on the other hand sufficient attention must be paid to assure system security and confidentiality.

Conventional security systems for radio communication systems include the radio terminal security system as described in Japanese Patent No. 2872996 and the one-time password system as used in the Internet.

These security systems include electronic keys and radio terminals and prohibit successive use of the same key to increase security, thereby providing increased safety against loss and theft of the key.

Next, the user authentication system used in the Bluetooth will be described.

The user authentication system used in the Bluetooth is subject to two: a unique password set up on each device (called a PIN (Personal Identification Number) code) and an encryption key (called link key) created by the password and an ID code unique to the device (information, such as a 48-bit address, assigned by IEEE). This system will be described in brief below with reference to a flowchart shown in FIG. 7.

Consider now the case where a device A makes access to a device B. The device A makes a request for connection to the device B (step A1), whereupon the device B checks the presence or absence of the link key to see if the connection to the device A is set up for the first time (step A2). That is, the device B is stored with a list of link keys besides PIN codes. This list is a table of unique addresses of devices connected so far to the device B and corresponding link keys. An example of this table is illustrated in FIG. 8.

In the situation in which the device A and the device B are connected for the first time, the device A is required to input

2

the PIN code of the device B. Upon receiving the PIN code from the device A, the device B checks it for validity (step A3). If the PIN code is authenticated, then the device B establishes a link (step A4) and creates a link key for the device A (step A5). The resulting link key is entered into the list together with the unique address of the device A (step A6).

If, on the other hand, the device A was sometimes connected to the device B in the past, since the link key has already been entered into the table in the device B, authentication is made through that link key (step A7).

The Bluetooth provides authentication using the PIN code unique to each device and the link key based on the PIN code. The PIN code, while being unique, can be altered by the device user into any other string of characters.

The security system disclosed in Japanese Patent No. 2872996, the one-time password system in the Internet and the user authentication system in the Bluetooth can be said to be password management and authentication systems intended to provide only increased security.

The use of the user authentication system in ad hoc network environment causes problems as described below.

As an application of the user authentication system used in the Bluetooth, consider a table conferencing system made up of a plurality of information devices. Each individual device is required to establish a fiduciary relationship based on the above user authentication system with the others.

However, in order for each individual user having his own private PIN code to ensure the security of his own device, it is desirable to adopt a method involving creating a temporary PIN code and changing it to the original private PIN code at the termination of the table conferencing rather than establishing the fiduciary relationship by informing the other users of the private PIN code.

To adopt the user authentication system as described above, therefore, it is required to take the following steps:

S1: Each individual user sets up a temporary PIN code on his own device and informs the other users of that PIN code.

S2: Holds table conferencing.

S3: At the termination of the conferencing, each individual user makes a change from the temporary PIN code to his original private PIN code.

With the above approach, however, not only does it take long to set up the PIN code, but also the security level is considerably lowered in the event that the user forgot to make a change from the PIN code to the original PIN code; for, in such case, the temporary PIN code will come to be used successively.

BRIEF SUMMARY OF THE INVENTION

It is therefore an object of the present invention to provide a radio communication device and a user authentication method for use therewith which permit the security level to be changed with flexibility according to communication situations without imposing any operating burden on users.

According to one aspect of the present invention, there is provided an authentication processing apparatus of a radio communication which authenticates a device, the apparatus comprising: means for selecting a security level from a plurality of security levels in accordance with a condition of the radio communication;

means for receiving a request for an authentication and authentication information from the device; means for checking whether the received information from the device

US 6,928,166 B2

3

is valid or not depending on the selected security level; and means for sending a response of the check result which authenticates or rejects the device thereto.

According to another aspect of the present invention, there is provided a radio communication device having a password unique to it and adapted for authenticating another device by use of the password, comprising: password holding means for holding at least a first password intended for temporary use and a second password intended for regular use; password selecting means for selecting an appropriate password from the password holding means according to a current communication condition; and password checking means for checking a password sent from another device with the password selected by the password selecting means to thereby authenticate the another device.

According to still another aspect of the present invention, there is provided a authentication processing method of a radio communication which authenticates a device, the method comprising the steps of: selecting a security level from a plurality of security levels in accordance with a condition of the radio communication; receiving a request for an authentication from the device; receiving authentication information from the device; checking whether the received information from the device is valid or not depending on the selected security level; and sending a response of the check result which authenticates or rejects the device thereto.

According to still another aspect of the present invention, there is provided a radio communication method communicating with a device, the method comprising the steps of: storing a first password intended for temporary use and a second password intended for regular use; selecting the first password depending on a variable security level; receiving a request for a connection from the device; receiving a password for an authentication from the device; checking whether the received password from the device and the selected first password correspond or not; sending a response of the check result which authenticates or rejects the device thereto; performing a low-security-level communication with the authenticated device based on the connection; and changing over, when the communication is terminated, the security level to higher one than that of the first password and selecting the second password.

Additional objects and advantages of the invention will be set forth in the description which follows, and in part will be obvious from the description, or may be learned by practice of the invention. The objects and advantages of the invention may be realized and obtained by means of the instrumentalities and combinations particularly pointed out hereinafter.

BRIEF DESCRIPTION OF THE SEVERAL VIEWS OF THE DRAWING

The accompanying drawings, which are incorporated in and constitute a part of the specification, illustrate presently preferred embodiments of the invention, and together with the general description given above and the detailed description of the preferred embodiments given below, serve to explain the principles of the invention.

FIG. 1 is a block diagram of a radio communication device according to an embodiment of the present invention;

FIG. 2 is a diagram for use in explanation of device-to-device communication in the embodiment;

FIG. 3 illustrates the flow of processing from a request for connection to the completion of authentication in the embodiment;

4

FIG. 4 is a flowchart for switching between a temporary password and a private password in the embodiment;

FIG. 5 is a diagram for use in explanation of how conferencing passwords are selected in an electronic conferencing system;

FIG. 6 is a diagram for use in explanation of management of passwords of slave stations through ID information of a master station in a radio communication system composed of multiple radio communication devices;

FIG. 7 is a flowchart for user authentication in the Bluetooth system; and

FIG. 8 shows the contents of the table used in the user authentication processing shown in FIG. 7.

DETAILED DESCRIPTION OF THE INVENTION

FIG. 1 is a block diagram of a radio communication device according to an embodiment of the present invention, which comprises a data transmitting and receiving section 11, an antenna 12, a connection-break detecting section 13, an external factor acquisition section 14, a time control section 15, a password holding section, a password management section 17, a password selecting section, a password checking section 19, and an authentication password input section 20. User events 21 are applied to the password management section 17, the password selecting section 18, and the authentication password input section 20.

The data transmitting and receiving section 11 makes radio communication with other devices through the antenna 12, performs low-level framing and synchronous processing, and can perform error detection and correction as required.

The connection-break detecting section 13 examines data receiving conditions in the data transmitting and receiving section 11 to detect whether the device with which the connection has been set up lies outside the coverage area and presents the result to the password selecting section 18. The connection-break detecting section 13 is also configured to allow the user to set arbitrarily parameters, such as timer values, receiving sensitivity, etc., for recognizing connection break, that is, to set optimum values so that the password is not readily switched to another one in the event of bad data receiving conditions. Although, in FIG. 1, the connection-break detecting section 13 is provided independently, it may be incorporated into the external factor acquisition section 14.

The external factor acquisition section 14 identifies external factors, for example, the presence or absence of AC power supply, the presence or absence of wireless connection, such as Bluetooth, IrDA, etc., or wired connection, such as USB, IEEE1394, etc., and controls the password selecting section 18 correspondingly.

The time control section 15 controls time information in terms of absolute time or relative time and, at the occurrence of timer runout, notifies the password selecting section 18 of it.

The password holding section 16 is a memory that stores a plurality of passwords for authenticating the device (e.g., two passwords: a temporary password and a private password). The temporary password is one which is valid only during the duration of connection with a certain device and intended for temporary use, whereas the private password is one which ensures high confidentiality to increase the security of the device and is intended for regular use. The password management section 17 is adapted to add new

US 6,928,166 B2

5

passwords to the contents of the password holding section 16 or deleting existing passwords therefrom according to events 21 from the user.

The password selecting section 18 selects the most suitable password for current connection from among the passwords stored in the password holding section 16 according to the user events 21, information acquired by the external factor acquisition section 14, and information from the time control section 15 and sends it to the password checking section 19. The password selecting section is configured to be able to establish priority among the user event 21, the external factor acquisition section 14, and the time control section 15.

When operating on an external factor acquired by the external factor acquisition section 14, the password selecting section 18 carries out a password changing operation dependent on the external factor, as follows:

(a) In the absence of AC power supply, i.e., when the device is battery-powered, the device is recognized as being in the mobile environment and hence the private password is chosen.

(b) When a cable is connected, the device is recognized as being in the indoor environment and as a result the temporary password is chosen.

(c) When no radio carrier signal is received from a server, the device is recognized as having moved from the office to the outside, in which case the private password is chosen.

The password checking section 19 checks the password determined by the password selecting section 18 with an authentication password sent from a person with which the connection has been set up, thus implementing appropriate user authentication. The authentication password input section 20 enters the authentication password into the data transmitting and receiving section 11 according to the user event 21.

Next, the authentication operation according to the present embodiment will be described.

Suppose now that devices A and B are about to be connected together as shown in FIG. 2. In this case, the authentication procedure is performed when the device A enters the authentication password for the device B.

As shown in FIG. 3, first, the user at the device A makes a request for connection. In response to this, the data transmitting and receiving section 11 in the device A issues a request for connection and transmits information from the antenna 12 (step B1).

Upon receiving the connection request from the device A, the data transmitting and receiving section 11 in the device B examines the received data and, in the case of no problem, sends a message to establish connection to the device A (step B2). After that, the connection is set up between the devices A and B (step B3). The connection in this case means the connection in low-level layer (e.g., the situation in which a virtual network address has been set up) and does not necessarily means high application services.

After the connection has been set up, the authentication procedure on the password is carried out. That is, the device B upon setting up the connection issues a request for authentication to the device A and prompts it to enter a password (step B4). In response to this, the user at the device A enters the password to the device B from the password input section 20 into the data transmitting and receiving section 11 for transmission to the device B (step B5).

Upon receipt of the password, the device B checks it with an authentication password chosen by the password select-

6

ing section 18. If the result indicates that the received password is improper, then the device B sends to the device A a message to the effect that the password is incorrect. If, on the other hand, the received password is correct, then the user authentication procedure comes to an end (step B6).

In the user authentication procedure, each individual user generally uses an authentication password having much increased confidentiality, thereby providing increased security for his own device. However, in applications of highly ad hoc nature, such as table conferencing, card exchange, etc., an easy-to-handle environment may be expected to be built up even if the security for devices is lowered temporarily. The procedure for implementing such an environment will be described below.

Consider now the case of card exchange with a complete stranger in a card exchange application installed in personal digital assistants (PDAs). In this case as well, user authentication is performed between the devices A and B.

The user at the device B generally uses a private password having much increased confidentiality as the authentication password so as to increase the security for his own device. However, to inform a stranger of the private password in such a situation as in this example is not desirable from the viewpoint of security. For this reason, the user at the device B sets up such a password (temporary password) as is valid only while the connection with the device A is set up and uses the temporary password for user authentication.

The switching control between the private password and the temporary password (security level control) will be described below with reference to a flowchart illustrated in FIG. 4.

The user at the device B issues a command which is based on the event 21 to the password selecting section 18 (step C1) and then sets up the temporary password as the authentication password (step C2). After that, the device B is placed in the wait state until a connection request is generated from the device A (step C3). The temporary password is very simple one (e.g., "ABC") as compared with the private password and presented to the user at the device A. In an extreme case, communication could be made between the devices A and B with no password. Making the temporary password simple as described above will make it possible to notify the user at the device A of the temporary password orally. Additionally, the temporary password may be sent to the device A along with electronic mail.

The user at the device A received notification from the device B makes a request to the device for connection and enters the temporary password.

In response to the connection request by the device A, the device B sets up the connection with the device A and then carries out authentication processing on the temporary password. After that, the devices A and B make data communications with each other on the card exchange application.

The device B makes a check for the termination of the card exchange application, i.e., for the break of the connection with the device A (step C5). Upon detecting the break of the connection, the device B negates the validity of the temporary password and makes an automatic change from the temporary password to the private password (step C6).

One method to automatically make a change from the temporary password to the private password is to associate the lifetime of the temporary password with the lifetime of the communication connection as will be described below.

That is, in FIG. 1, at the time of a break of the connection set up with the current temporary password the connection

US 6,928,166 B2

7

break detecting section **13** notifies the password selecting section **18** that the connection has been broken. The password selecting section then makes a change from the currently selected password to the private password.

The temporary password may be associated with time information using the time control section **15** rather than with the connection. In this case, a timer value for the temporary password can be freely set by the user in the time control section **15**. For example, if there is a two-hour conference, then the temporary password is used for two hours and changed to the private password two hours later.

A password which is to be made valid at present is usually chosen by the user through the graphical user interface (GUI). Alternatively, the password may be chosen by an operation of double clicking a password file. For example, in using an application such as an electronic conferencing system, a method can be utilized by which a password file **26** storing information used for selecting a conferencing password is distributed beforehand from a device **A** to other devices **B**, **C** and **D** over a communication path such as for electronic mail **25** and conference participants are allowed to choose a conferencing password by merely double clicking the file. In this case, the password selecting section **18** chooses a password held in the password holding section **16** according to the information read from the password file **26**.

The use of the password file **26** allows an appropriate password to be chosen by a simple operation of double clicking that file with a mouse. Also, the use of the password file allows passwords to be set up without their contents becoming known to the conference participants.

The password file **26** may be stored with passwords themselves rather than password select information. In this case, a password selected from the file may be automatically set up as the authentication password.

The password file **26** may be distributed to devices through electronic mail by radio.

Next, in a radio communication system made up of a plurality of radio communication devices each having the above functions, the management of passwords of the slave devices through ID information of the master device will be described.

Switching is made between authentication passwords in order to, for example, lower the security level of an information device when it is inside an office so that anybody can make access to it and enhance the security level when it is outside the office to prevent access by a third party.

Specifically, as shown in FIG. 6, a server (master device) **32** for managing the security level is installed in office **31** to detect whether an information device (slave device) **33** stays in the range of connection with the server through its connection break detecting section **13**. In the situation where the information device **33** is connected with the server **32**, a temporary password (or no password) is selected. In the situation where the connection with the server is broken, the private password is chosen.

The above configuration causes the server **32** to act as the key to password switching.

Although the embodiment has been described in terms of one-way authentication between the devices **A** and **B**, mutual authentication is also possible.

According to the present invention, as described in detail above, a radio communication device adapted to perform a authentication procedure on another device using its unique address is configured to hold at least two separate passwords of a temporary password and a private password and make

8

a choice from the two passwords for the procedure of authenticating the other device according to the current communication situations. Accordingly, depending upon what application is used, an appropriate password can be used for authentication and an easy-to-handle communication environment can be implemented in which a high level of security can be maintained at the time of usual communication and the security level can be lowered at the time of temporary communication.

Moreover, the inventive device is configured to usually choose the private password as authentication password, use the temporary password at the time of occurrence of a request by a user at another device for authentication thereof, and reuse the private password after the connection set up by the authentication procedure using the temporary password has been broken; therefore, there is no need for users to be conscious of a change from the temporary password to the private password.

Furthermore, the inventive device is configured to have external factor acquisition means, choose either of the temporary password and the private password for authentication of another device on the basis of information acquired by the external factor acquisition means; thus, the most suitable password can be automatically chosen according to communication situations.

In addition, the inventive device is configured to acquire position information of the device by external factor acquisition means or connection break detecting means and allow switching between the temporary password and the private password according to the position information; thus, the security level of the device can be changed automatically according to its location.

Additional advantages and modifications will readily occur to those skilled in the art. Therefore, the invention in its broader aspects is not limited to the specific details and representative embodiments shown and described herein. Accordingly, various modifications may be made without departing from the spirit or scope of the general inventive concept as defined by the appended claims and their equivalents.

What is claimed is:

1. An authentication processing apparatus of a radio communication which authenticates a device, the apparatus comprising:

means for acquiring an external factor which is associated with a security level;

means for selecting a security level from a plurality of security levels in accordance with the external factor;

means for receiving a request for an authentication and authentication information from the device;

means for checking whether the received information from the device is valid or not depending on the selected security level; and

means for sending a response of the check result which authenticates or rejects the device thereto.

2. An authentication processing apparatus according to claim **1**, wherein said authentication information includes a PIN (Personal Identification Number) code.

3. An authentication processing apparatus according to claim **2**, further comprising means for storing a link-key comprising said PIN code and a unique ID of said device.

4. An authentication processing apparatus according to claim **1**, further comprising means for detecting a connection-break from the device and changing over said security level in response to the connection-break.

5. A radio communication device having a password unique to it and adapted for authenticating another device by use of the password, comprising:

US 6,928,166 B2

9

password holding means for holding at least a first password intended for temporary use and a second password intended for regular use;

password selecting means for selecting an appropriate password from the password holding means according to a current communication condition; and

password checking means for checking a password sent from another device with the password selected by the password selecting means to thereby authenticate the other device.

6. The radio communication device according to claim 5, wherein said password selecting means selects a password according to information from a password file.

7. A radio communication device having a password unique to it and adapted for authenticating another device by use of the password, comprising:

password holding means for holding at least a first password intended for temporary use and a second password intended for regular use;

password management means for entering a new password into the password holding means and deleting an existing password in the password holding means;

password selecting means for selecting an appropriate password from the password holding means according to current communication situations; and

password checking means for checking a password sent from another device with the password selected by the password selecting means to thereby authenticate the other device.

8. A radio communication device having a password unique to it and adapted for authenticating another device by use of the password, comprising:

password holding means for holding at least a first password intended for temporary use and a second password intended for regular use;

password selecting means for selecting an appropriate password from the password holding means according to current communication situations;

password checking means for checking a password sent from another device with the password selected by the password selecting means to thereby authenticate the other device; and

connection break detecting means for detecting radio communication conditions and, upon detecting a connection break as a result of the device having moved to the outside of a communication service area, notifying the password selecting means of the connection break, the password selecting means usually choosing the second password as an authentication password, using the first password at the time of occurrence of a request by a user at the other device as the authentication password, and reusing the second password after the connection set up by the authentication procedure using the first password has been broken.

9. The radio communication device according to claim 8, wherein the connection break detecting means includes means for setting parameters containing timer values and receiving sensitivity for recognizing the connection break.

10. A radio communication device having a password unique to it and adapted for authenticating another device by use of the password, comprising:

password holding means for holding at least a first password intended for temporary use and a second password intended for regular use;

external factor acquisition means;

10

password selecting means for selecting an authentication password from the password holding means on the basis of information acquired by the external factor acquisition means; and

password checking means for checking a password sent from another device with the password selected by the password selecting means to thereby authenticate the other device.

11. A radio communication device having a password unique to it and adapted for authenticating another device by use of the password, comprising:

password holding means for holding at least a first password intended for temporary use and a second password intended for regular use;

password selecting means for selecting an appropriate password from the password holding means according to current communication situations;

password checking means for checking a password sent from another device with the password selected by the password selecting means to thereby authenticate the other device; and

time control means for counting time to provide management information on a set time to the password selecting means,

the password selecting means usually choosing the second password as an authentication password, using the first password at the time of occurrence of a request by a user at the other device as the authentication password, and setting the second password as the authentication password at the expiration of the time set by the time management means.

12. A radio communication device having a password unique to it and adapted for authenticating another device by use of the password, comprising:

password holding means for holding at least a first password intended for temporary use and a second password intended for regular use;

password selecting means for selecting an appropriate password from the password holding means according to current communication situations; and

password checking means for checking a password sent from another device with the password selected by the password selecting means to thereby authenticate the other device,

each of the devices acting as slave stations recognizing information unique to a master station, selecting one of the first and second passwords in a state where it can communicate with the master station, and selecting the other password in a state where it cannot communicate with the master station.

13. An authentication processing method of a radio communication which authenticates a device, the method comprising:

selecting a security level from a plurality of security levels in accordance with a condition of the radio communication;

receiving a request for an authentication from the device; receiving authentication information from the device;

checking whether the received information from the device is valid or not depending on the selected security level; and

sending a response of the check result which authenticates or rejects the device thereto.

14. An authentication processing method according to claim 13, wherein said authentication information includes a PIN (Personal Identification Number) code.

US 6,928,166 B2

11

15. An authentication processing method according to claim 14, further comprising the step of storing a link-key comprising said PIN code and a unique ID of said device.

16. An authentication processing method according to claim 13, further comprising the step of acquiring an external factor which is associated with said security level. 5

17. A radio communication method communicating with a device, the method comprising:

storing a first password intended for temporary use and a second password intended for regular use; 10

acquiring an external factor which is associated with a variable security level;

selecting the first password depending on a variable security level;

receiving a request for a connection from the device; 15

receiving a password for an authentication from the device;

12

checking whether the received password from the device and the selected first password correspond or not;

sending a response of the check result which authenticates or rejects the device thereto;

performing a low-security-level communication with the authenticated device based on the connection; and

changing over, when the communication is terminated, said security level to a higher one than that of said first

password and selecting said second password.

18. A radio communication method according to claim 17, wherein said second password includes a PIN (Personal Identification Number) code.

19. A radio communication method according to claim 18, further comprising the step of storing a link-key comprising said PIN code and a unique ID of said device.

* * * * *

EXHIBIT 4

TP-Link WiFi Routers



AC1200 Wireless Dual Band Router

Archer C50 V5

- Supports 802.11ac standard
- Simultaneous 2.4GHz 300 Mbps and 5GHz 867 Mbps connections for 1200 Mbps of total available bandwidth
- 2 external antennas provide stable wireless connections and optimal coverage
- Easy network management at your fingertips with TP-Link Tether
- Supports IGMP Proxy/Snooping, Bridge and Tag VLAN to optimize IPTV streaming
- Supports Access Point mode to create a new Wi-Fi access point

13. An authentication processing method of a radio communication which authenticates a device, the method comprising:

selecting a security level from a plurality of security levels in accordance with a condition of the radio communication;

receiving a request for an authentication from the device;

receiving authentication information from the device;

checking whether the received information from the device is valid or not depending on the selected security level; and

sending a response of the check result which authenticates or rejects the device thereto.

Claim 13

Source: <https://www.TP-Link.com/us/home-networking/wifi-router/archer-c90/>

An authentication processing method of a radio communication which authenticates a device, the method comprising:



4. 4. Configure the Router in Access Point Mode

In this mode, your router connects to a wired or wireless router via an Ethernet cable and extends the wireless coverage of your existing network. Advanced functions like NAT, Parental Controls and QoS are not supported in this mode.

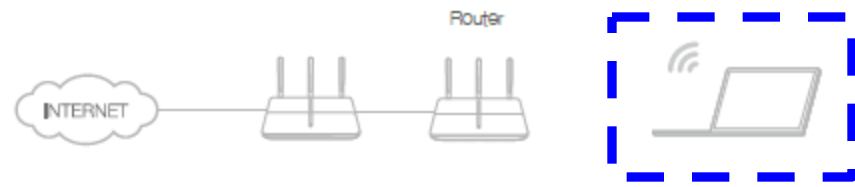

Claim 13

selecting a security level from a plurality of security levels in accordance with a condition of the radio communication;

Source: https://static.tp-link.com/2018/201802/20180224/1910012180_Archer%20C1200_UG.pdf pg 27.

Wireless 2.4GHz | 5GHz

2.4GHz Wireless: Enable Guest Network

Network Name (SSID): Hide SSID

Security: No Security WPA/WPA2-Personal

Version: Auto WPA-PSK WPA2-PSK

Encryption: Auto TKIP AES

Password:

Save

{e.g. "condition" is 2.4 Ghz or 5 Ghz}

Claim 13

Source: <http://80211notes.blogspot.com/2013/11/sta-ap-wpa2-psk-connection-establishment.html>

receiving a
request for an
authentication
from the device;

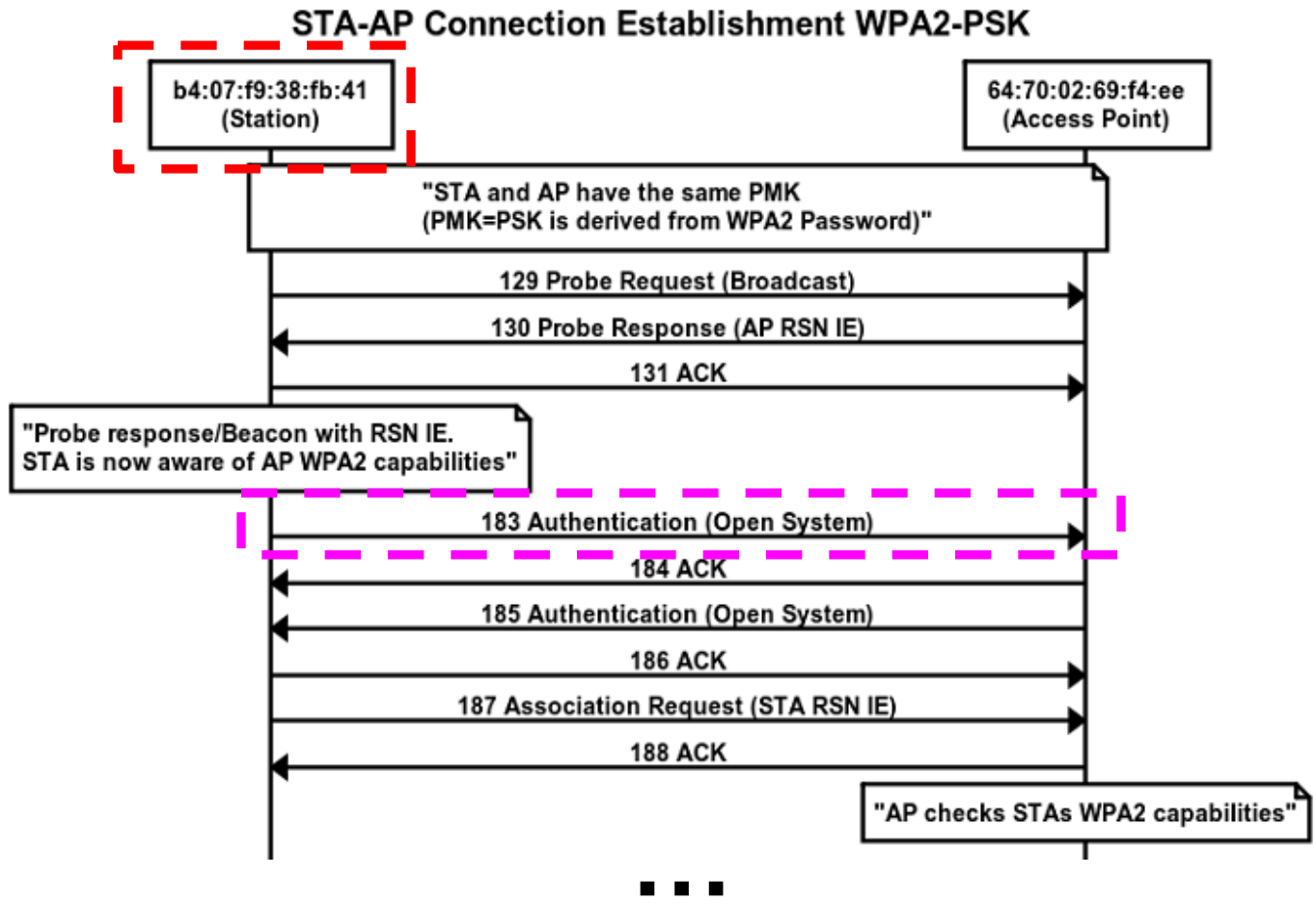

Claim 13

receiving authentication information from the device;

checking whether the received information from the device is valid or not depending on the selected security level; and

Source: <http://80211notes.blogspot.com/2013/11/sta-ap-wpa2-psk-connection-establishment.html>

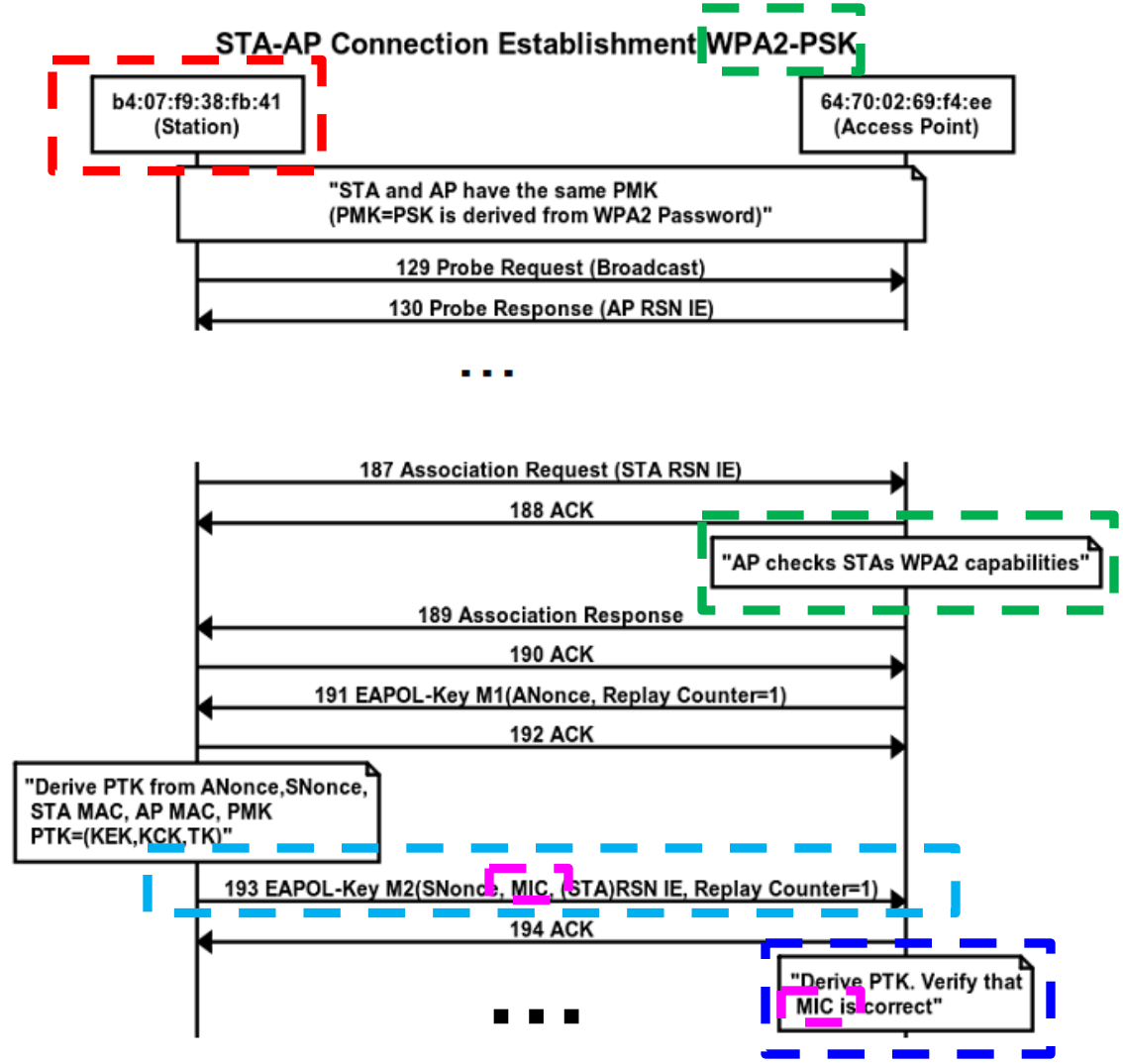

Claim 13

sending a response of the check result which authenticates or rejects the device thereto.

Source: <http://80211notes.blogspot.com/2013/11/sta-ap-wpa2-psk-connection-establishment.html>

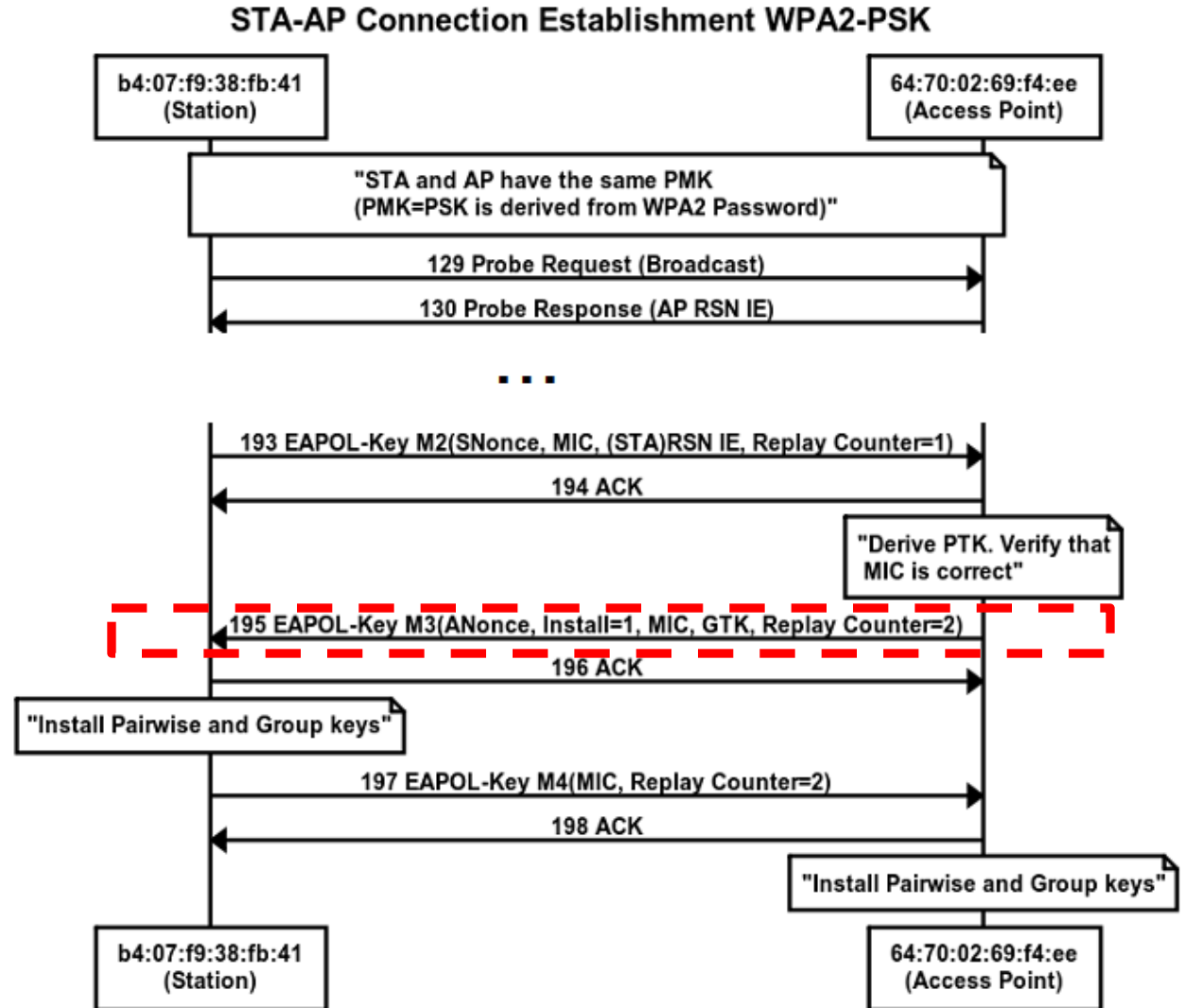

EXHIBIT 5



US007039445B1

(12) **United States Patent**
Yoshizawa

(10) **Patent No.:** **US 7,039,445 B1**
(45) **Date of Patent:** **May 2, 2006**

(54) **COMMUNICATION SYSTEM,
COMMUNICATION APPARATUS, AND
COMMUNICATION METHOD**

(75) Inventor: **Junichi Yoshizawa, Ome (JP)**

(73) Assignee: **Kabushiki Kaisha Toshiba, Kawasaki (JP)**

(*) Notice: Subject to any disclaimer, the term of this patent is extended or adjusted under 35 U.S.C. 154(b) by 778 days.

(21) Appl. No.: **09/713,250**

(22) Filed: **Nov. 16, 2000**

(30) **Foreign Application Priority Data**

Nov. 18, 1999 (JP) 11-328327

(51) **Int. Cl.**
H04M 1/00 (2006.01)

(52) **U.S. Cl.** **455/575.7; 455/293; 455/41.2; 455/63.4; 343/754**

(58) **Field of Classification Search** 455/41.1-41.3, 455/25, 193.1, 269, 271, 273-277.2, 281, 455/575.7, 575.1, 550.1, 66.1, 344, 461, 455/63.4; 343/754-766

See application file for complete search history.

(56) **References Cited**

U.S. PATENT DOCUMENTS

5,636,243	A *	6/1997	Tanaka	375/219
5,714,961	A *	2/1998	Kot et al.	343/769
5,737,325	A *	4/1998	Fukuda	370/337
5,781,860	A *	7/1998	Lopponen et al.	455/426.1
5,790,938	A *	8/1998	Talaro	455/11.1
5,842,130	A *	11/1998	Oprescu-Surcobe et al.	455/456.2
5,907,794	A *	5/1999	Lehmusto et al.	455/11.1
5,995,500	A *	11/1999	Ma et al.	370/337
6,115,370	A *	9/2000	Struhsaker et al.	370/342

6,137,785	A *	10/2000	Bar-Ness	370/328
6,188,913	B1 *	2/2001	Fukagawa et al.	455/562.1
6,246,376	B1 *	6/2001	Bork et al.	343/760
6,289,218	B1 *	9/2001	Liu	455/426.1
6,370,377	B1 *	4/2002	Take et al.	455/432.1
6,456,856	B1 *	9/2002	Werling et al.	455/575.5
6,480,699	B1 *	11/2002	Lovoi	455/41.2
6,484,027	B1 *	11/2002	Mauney et al.	455/421
6,654,614	B1 *	11/2003	Morris et al.	455/426.1
2001/0051530	A1 *	12/2001	Shiotsu et al.	455/522

FOREIGN PATENT DOCUMENTS

JP	9-186649	7/1997
JP	2002271229 A *	9/2002
WO	WO94/05101	* 8/1992

OTHER PUBLICATIONS

Copy of U.S. Patent Appl. No. 09/694,793, filed Oct. 24, 2000, to Ito.

* cited by examiner

Primary Examiner—Charles Craver

(74) *Attorney, Agent, or Firm*—Finnegan, Henderson, Farabow, Garrett & Dunner, LLP.

(57) **ABSTRACT**

A communication apparatus transmits, to another apparatus or apparatuses, a message for searching for an apparatus as a connection target by radio communication, and receives a response message from another apparatus which has received the message, thereby searching for an apparatus as a connection target. The control information setting section of the device body of a communication apparatus inputs a search range in which a station finding message reaches in accordance with designation by a user and sets it as set information. The station finding procedure section of the radio communication apparatus transmits the station finding message in accordance with a transmission power corresponding to the control information set by the control information setting section.

23 Claims, 10 Drawing Sheets

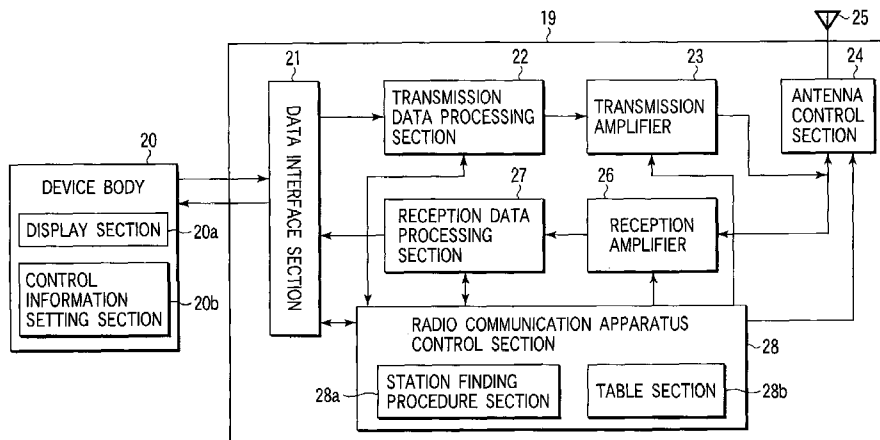

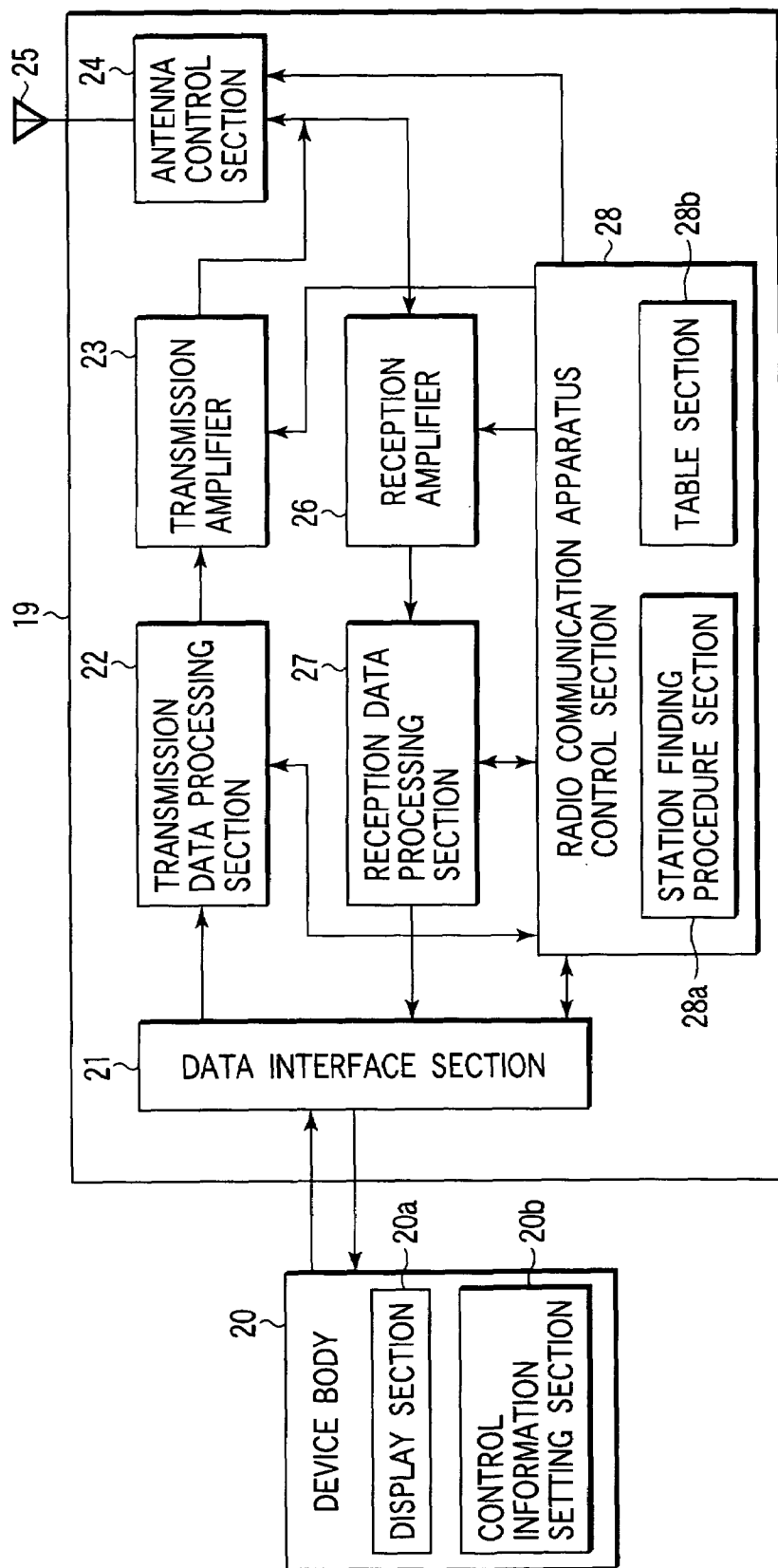

FIG. 1

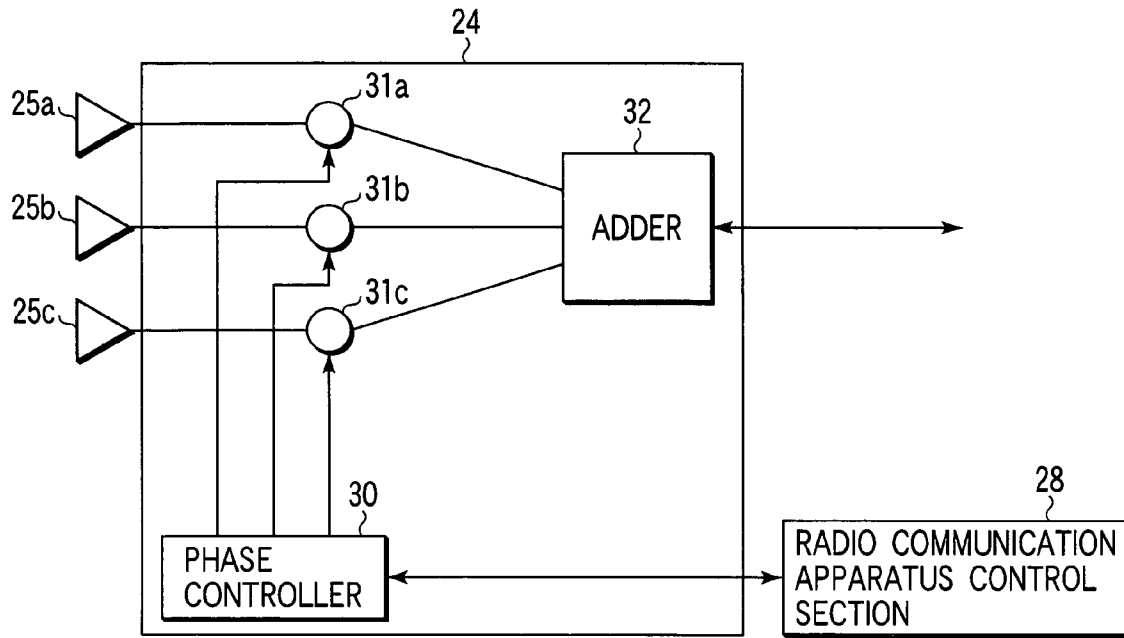
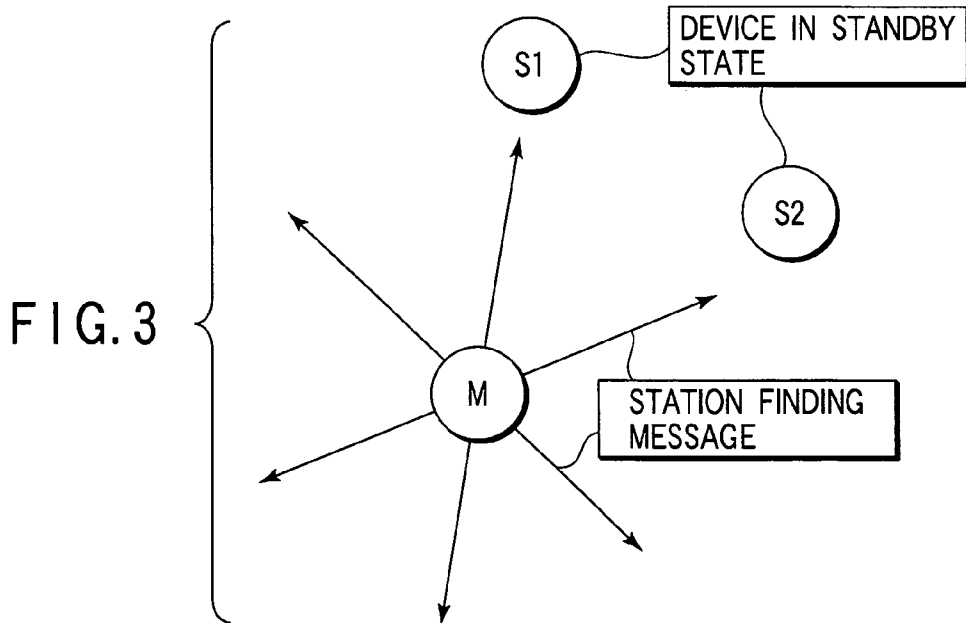

FIG. 2



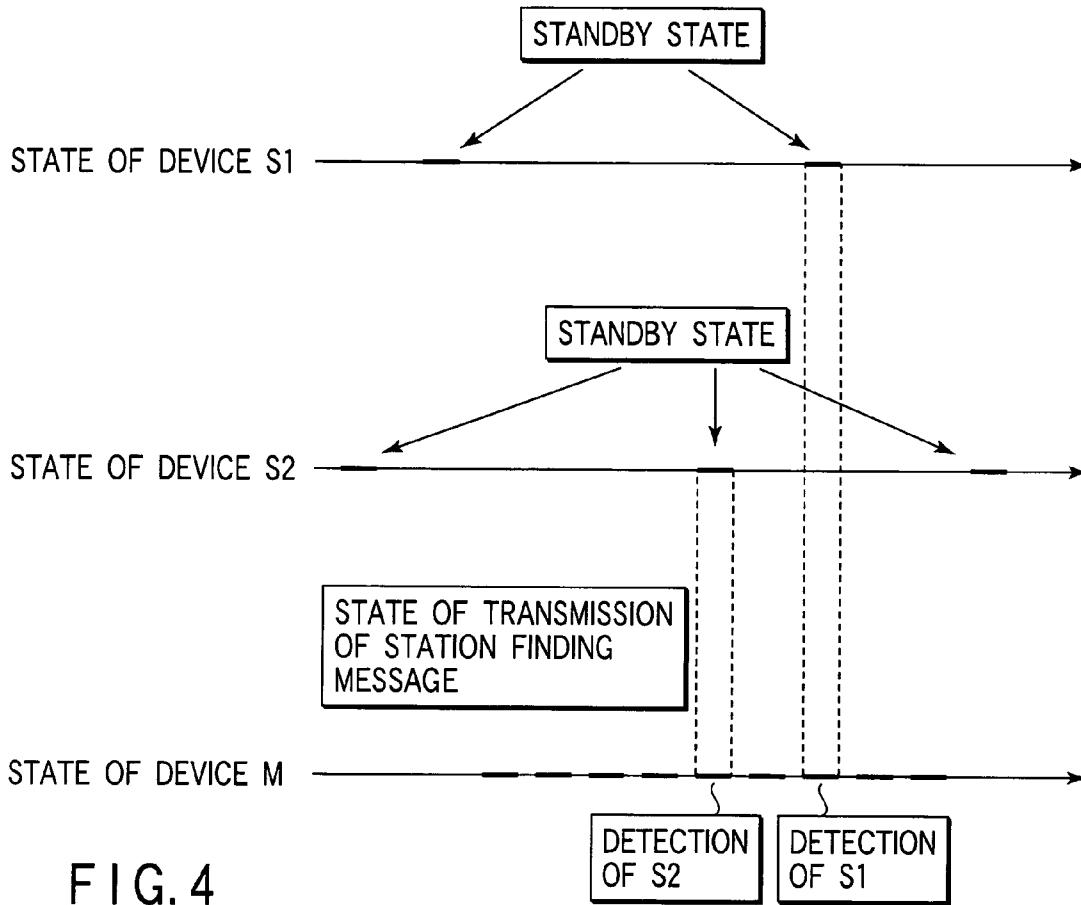

FIG. 4

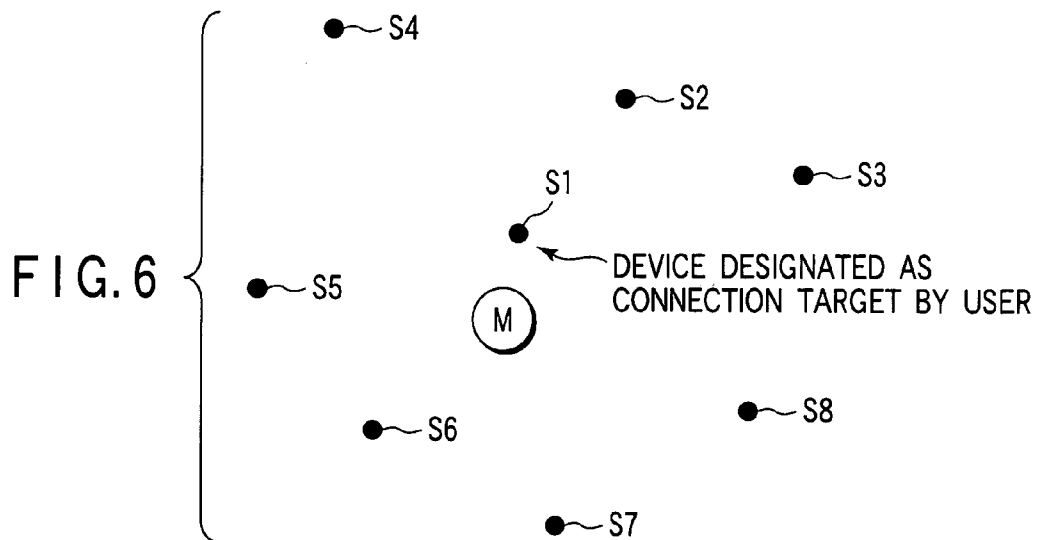

FIG. 6

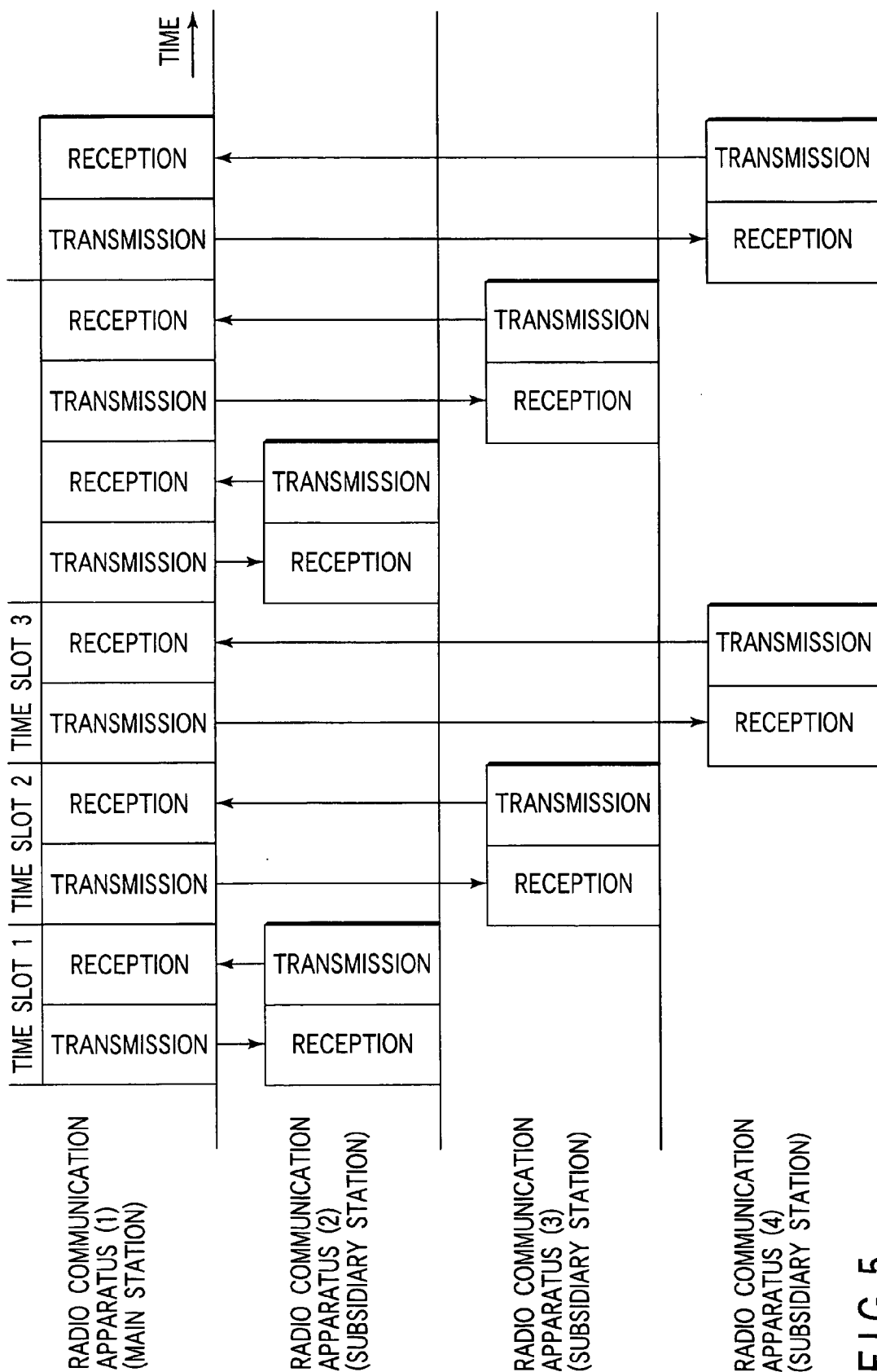

FIG. 5

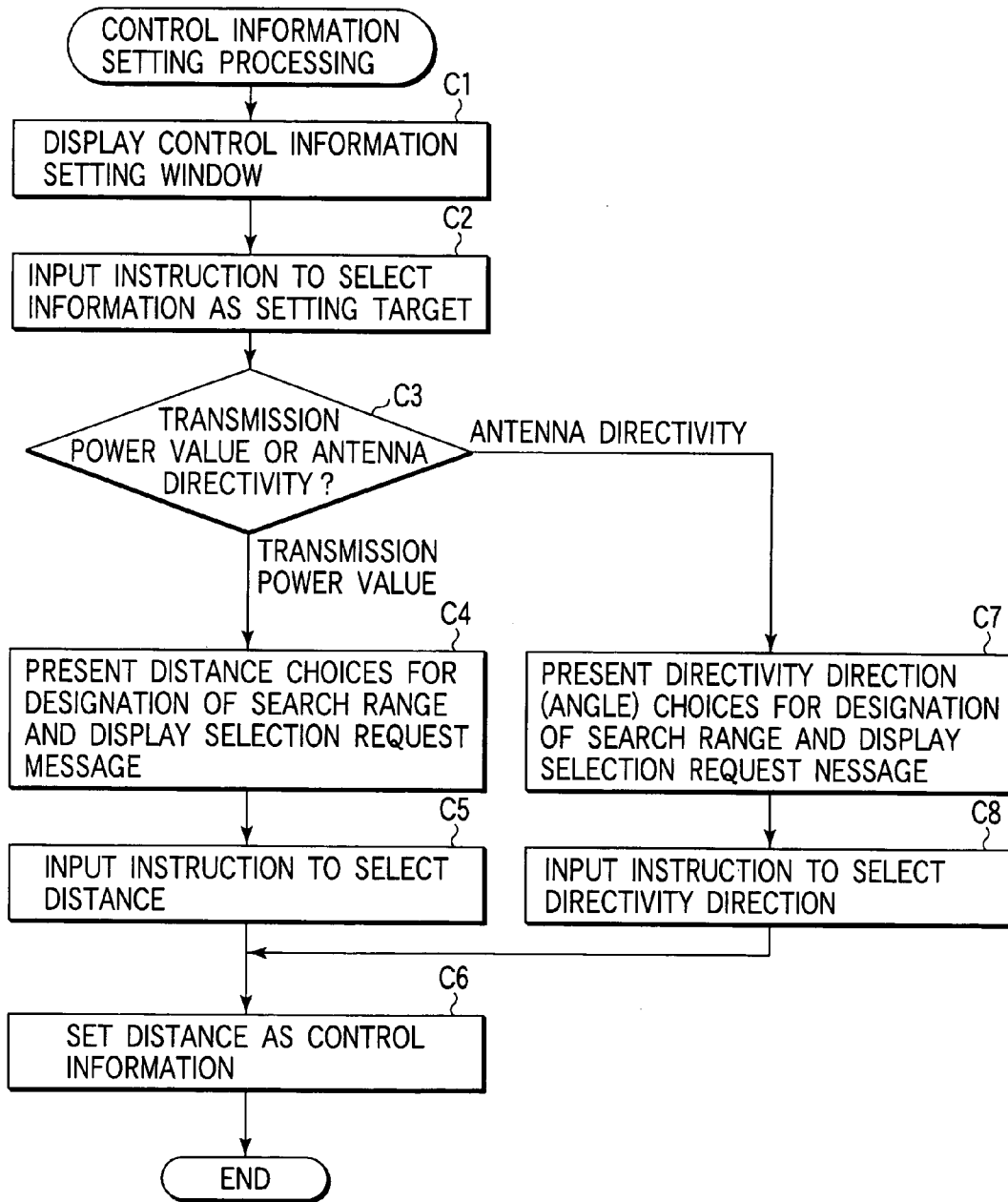

FIG. 7

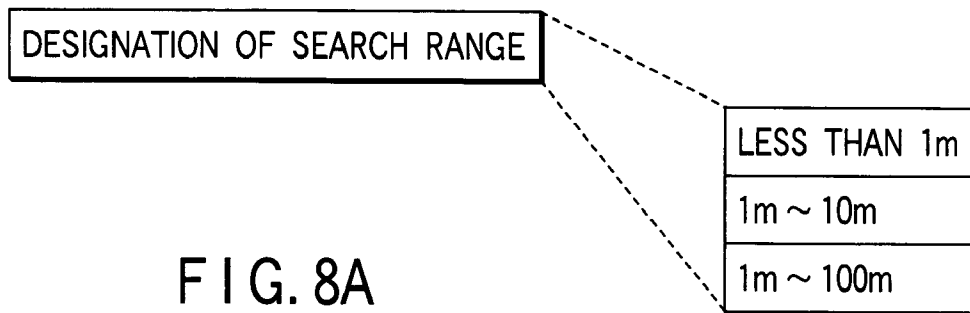

FIG. 8A

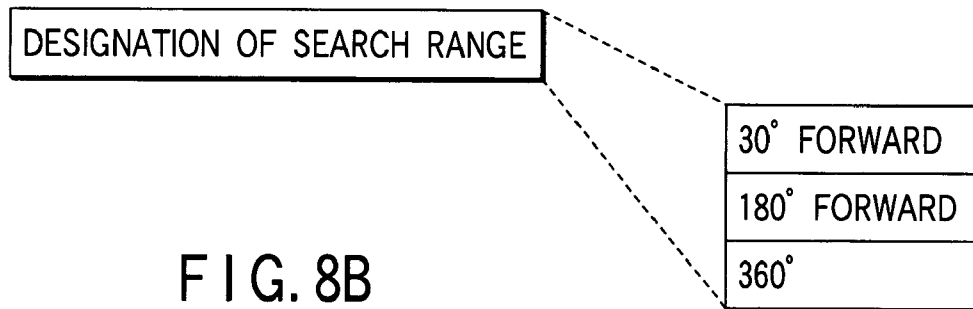

FIG. 8B

SEARCH RANGE	TRANSMISSION POWER
1m	1mW
1 ~ 10m	10mW
10 ~ 100	100mW

FIG. 9

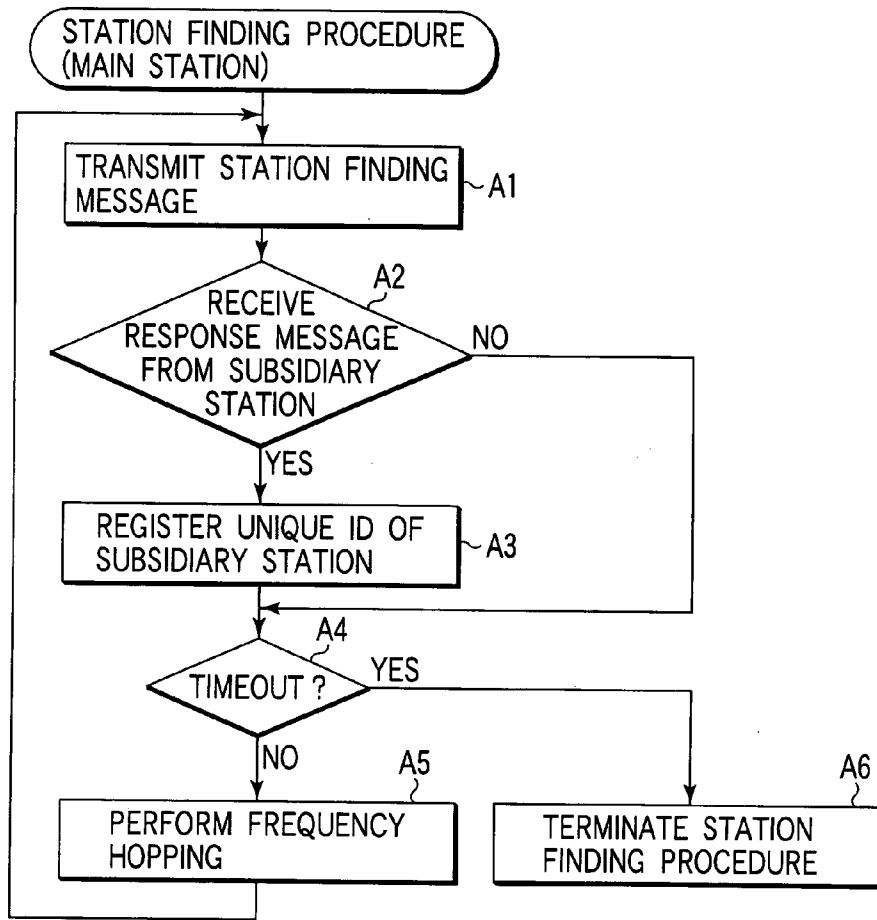

FIG. 10

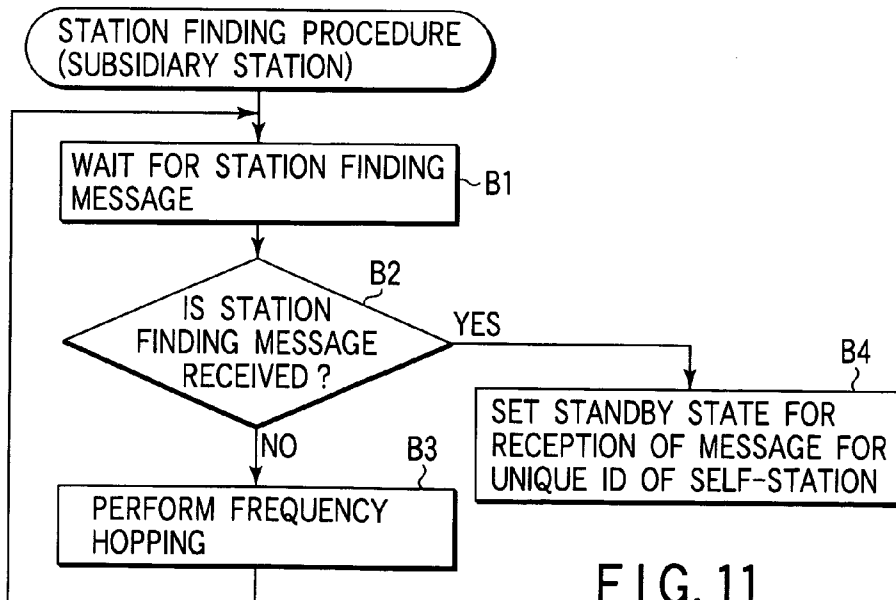
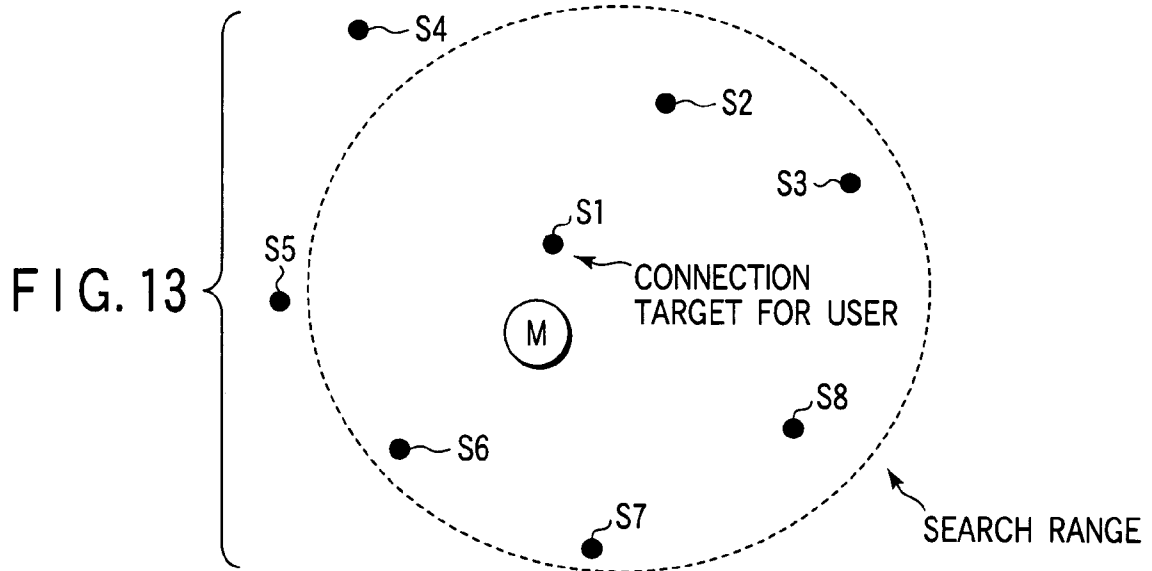
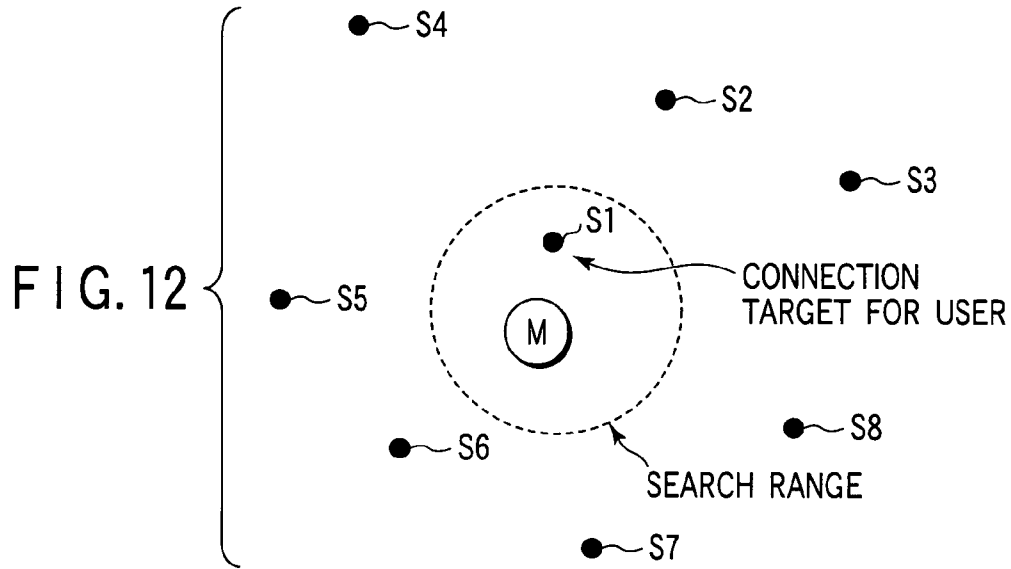

FIG. 11



TRANSMISSION POWER VALUE	STATION FINDING PROCEDURE TIME
10mW	1SECOND
100mW	5SECOND
1W	10SECOND

FIG. 14

DEVICE NUMBER	DEVICE ADDRESS
1	A39B31
2	244A15
...	...

FIG. 16A

DEVICE NUMBER	DEVICE CLASSIFICATION	DEVICE NAME
1	PC	LUNA
2	PRINTER	APOLON
...

FIG. 16B

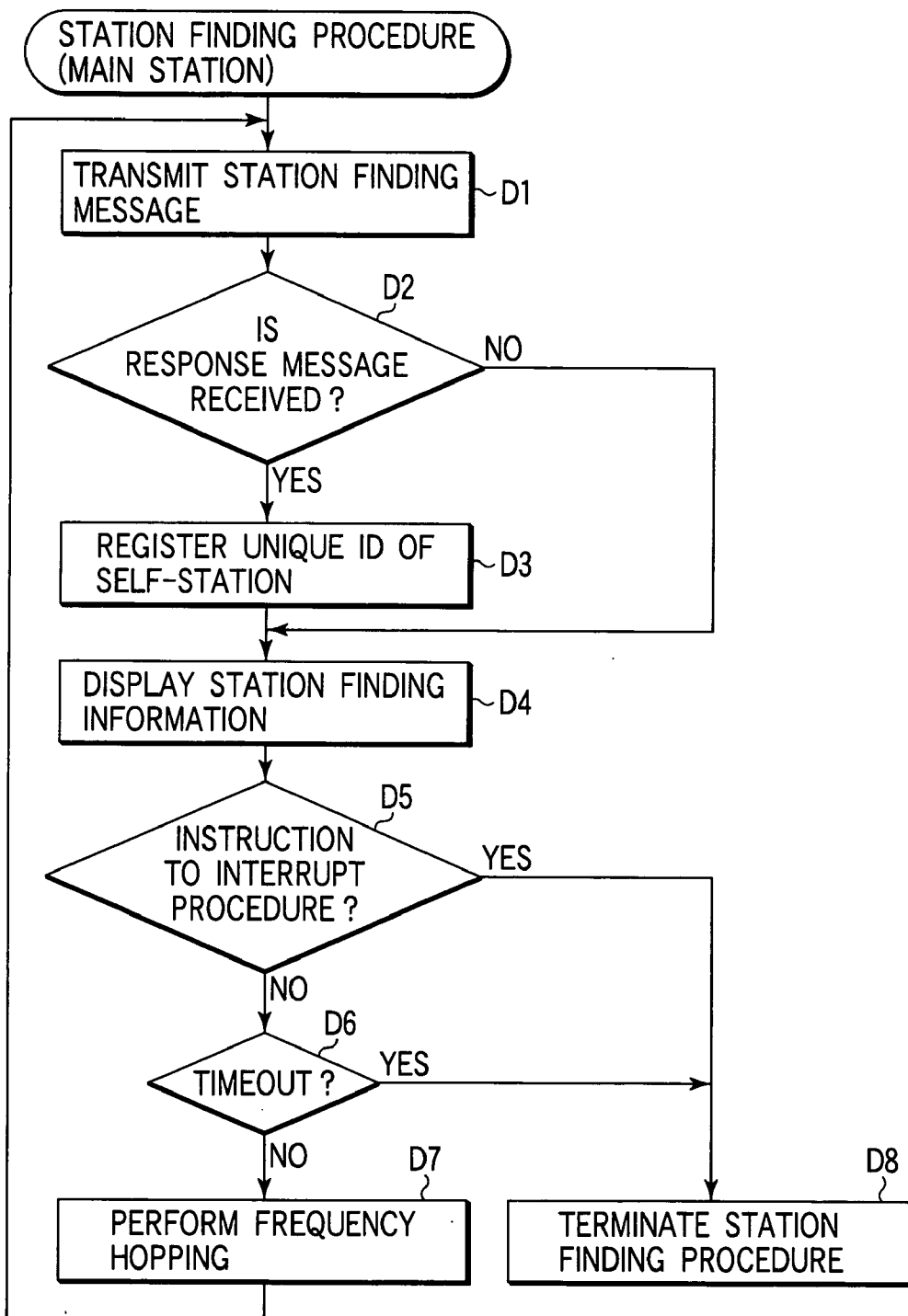

FIG. 15

US 7,039,445 B1

1

**COMMUNICATION SYSTEM,
COMMUNICATION APPARATUS, AND
COMMUNICATION METHOD**

CROSS-REFERENCE TO RELATED
APPLICATIONS

This application is based upon and claims the benefit of priority from the prior Japanese Patent Application No. 11-328327, filed Nov. 18, 1999, the entire contents of which are incorporated herein by reference.

BACKGROUND OF THE INVENTION

The present invention relates to a communication system having a main station and at least one subsidiary station, and a communication apparatus and method used in the system.

Recently, a great deal of attention has been paid to radio communication systems for personal areas, e.g., IrDA, Bluetooth, HomeRF systems. The Bluetooth and HomeRF systems, in particular, use RF signals, and hence have merits, e.g., no directivity and high transparency, as compared with infrared communication schemes such as the IrDA system. Therefore, further development and popularization of the Bluetooth and HomeRF systems are greatly expected.

Such a radio communication system allows simultaneous connection of a plurality of devices. In addition, one of the noticeable characteristic features of this system is that the transmission distance is relatively long (10 to 100 m). For this reason, in the Bluetooth or HomeRF system, when devices are to be actually connected to each other, there is no need to face them each other, unlike a communication system with a high directivity, e.g., the IrDA system, in which devices must be faced each other to specify the partner devices. In the case of Bluetooth, HomeRF, or the like, a station finding message is transmitted as a broadcast message from the main station, and response messages from subsidiary stations which have received the station finding message are received by the main station, thereby searching for a device that can communicate.

When Bluetooth, HomeRF, or the like is used, although the lack of directivity facilitates handling, since the station finding message is transmitted to all devices in a search range, response messages from devices other than target devices are received. As a consequence, a long time is spent to find a station. In addition, in general, all pieces of information received from devices in the search range must be displayed on a display means such as a display to notify a user of the information. Consequently, many pieces of information from stations other than stations that need to communicate are displayed. This makes it difficult for the user to perform a subsequent procedure for designating a destination station on the basis of the displayed information.

The present invention has been made in consideration of the above situation, and has as its object to provide a communication system and communication apparatus and method which can efficiently perform a station finding procedure in a short period of time by changing the reachable range of a station finding message in searching for a station as a connection target, efficiently perform designation of a station thereafter, and are easy for a user to use.

BRIEF SUMMARY OF THE INVENTION

According to the present invention, there is provided a communication apparatus for transmitting, to another apparatus, a message for searching for an apparatus as a con-

2

nection target by radio communication, and receiving a response message from another apparatus which has received the message, thereby searching for an apparatus as a connection target, comprising means for setting a range in which the message can reach, and means for transmitting the message in accordance with the set range by the setting means.

According to this arrangement, when another apparatus as a connection target is located near the self-apparatus, the reachable range of the message for searching for an apparatus as a connection target is narrowed to save the processing performed between the self-apparatus and other apparatuses that need not be connected, thereby efficiently performing a station finding procedure in a short period of time.

Additional objects and advantages of the invention will be set forth in the description which follows, and in part will be obvious from the description, or may be learned by practice of the invention. The objects and advantages of the invention may be realized and obtained by means of the instrumentalities and combinations particularly pointed out hereinafter.

BRIEF DESCRIPTION OF THE SEVERAL
VIEWS OF THE DRAWING

The accompanying drawings, which are incorporated in and constitute a part of the specification, illustrate presently preferred embodiments of the invention, and together with the general description given above and the detailed description of the preferred embodiments given below, serve to explain the principles of the invention.

FIG. 1 is a block diagram showing the arrangement of a device used in a communication system according to this embodiment;

FIG. 2 is a block diagram showing the detailed arrangements of an antenna control section 24 and antenna 25;

FIG. 3 is a view showing how a station finding procedure is performed;

FIG. 4 is a view showing how the station finding procedure is performed;

FIG. 5 is a timing chart showing the timing of data transmission/reception in a case wherein a main station and a plurality of subsidiary stations are searched;

FIG. 6 is a view for explaining the positional relationship between an apparatus (subsidiary station) designated as a connection target by the user and the user (main station);

FIG. 7 is a flow chart showing control information setting processing for setting control information;

FIGS. 8A and 8B are views each showing an example of a field configuration in which choices for designation of a search range are presented;

FIG. 9 is a view showing the relationship between each distance as a search range and a corresponding transmission power for transmission of the station finding message from a radio communication apparatus 19;

FIG. 10 is a flow chart showing a station finding procedure in the main station on the basis of the control information set by control information setting processing;

FIG. 11 is a flow chart showing a station finding procedure in a subsidiary station on the basis of the control information set by control information setting processing;

FIG. 12 is a view for explaining how the search range is changed by a station finding procedure based on control information (when transmission power control is performed);

US 7,039,445 B1

3

FIG. 13 is a view for explaining how the search range is changed by a station finding procedure based on control information (when transmission power control is not performed);

FIG. 14 is a view showing an example of a table which links station finding procedure time choices to transmission power values prepared in advance;

FIG. 15 is a flow chart showing another method of a station finding procedure; and

FIGS. 16A and 16B are views each showing an example of display of station finding information.

DETAILED DESCRIPTION OF THE INVENTION

An embodiment of the present invention will be described below with reference to the views of the accompanying drawing. FIG. 1 is a block diagram showing the arrangement of a device used in a communication system according to this embodiment.

The communication system of this embodiment is formed such that a device functioning as a single main station (master) and at least one device functioning as a subsidiary station (slave) communicate with each other by radio. The communication system forms a radio network by using a plurality of radio communication apparatus mounted in the respective devices. FIG. 1 shows the arrangement of the device functioning as the main station.

As shown in FIG. 1, each device in this embodiment has a radio communication apparatus 19 for performing radio communication and a device body 20. The radio communication apparatus 19 is mounted and used in various types of information processing devices (personal computers and the like), communication devices, and the like. For example, the radio communication apparatus 19 performs radio communication by using the Bluetooth or HomeRF scheme.

Bluetooth and HomeRF are short-range radio communication standards. By using a 2.4-GHz ISM (Industry Science Medical) band, Bluetooth and HomeRF implement radio communication within 10 m and 50 m, respectively.

Bluetooth and HomeRF use a frequency hopping scheme as a spread spectrum technique. By using time-division multiplexing, in Bluetooth, it is possible to connect a maximum of eight devices; HomeRF, a maximum of 127 devices.

According to Bluetooth or HomeRF, a network is formed by using devices connected to each other by time-division multiplexing, with one device functioning as a main station (first device) and the remaining devices functioning as subsidiary stations (second devices). This network has the function of performing connection authentication by using a password called a PIN (Personal Identification Number) code.

The radio communication apparatus 19 has a data interface section 21, transmission data processing section 22, transmission amplifier 23, antenna control section 24, antenna 25, reception amplifier 26, reception data processing section 27, and radio communication apparatus control section 28. After a device (radio communication apparatus) serving as a target subsidiary station is detected by station finding processing (transmission of a station finding message and reception of a response message), the radio communication apparatus 19 executes basic data transmission/reception processing between the respective devices as follows.

In data transmission, the radio communication apparatus 19 converts transmission data received from the device body 20 through the data interface section 21 into an RF signal by

4

using the transmission data processing section 22. The apparatus 19 then amplifies the RF signal by using the transmission amplifier 23 and radiates the signal from the antenna 25 through the antenna control section 24 (to be described in detail later with reference to FIG. 2).

In data reception, the reception amplifier 26 amplifies an RF signal received by the antenna 25 and obtained through the antenna control section 24, and demodulates the RF signal by using the reception amplifier 26, thereby reconstructing the reception data. The apparatus 19 then outputs the data from the data interface section 21 to the device body 20.

The reception amplifier 26 executes data processing for the reception data amplified by the reception amplifier 26 and having an effective level upon checking identification information (ID) or the like for identifying the data transmission source device.

The radio communication apparatus control section 28 implements the above data transmission/reception by controlling the respective sections, and has a station finding procedure section 28a and table section 28b. The station finding procedure section 28a controls the transmission data processing section 22, transmission amplifier 23 and antenna control section 24 so as to transmit a station finding message as a broadcast message, and to receive a response message from a subsidiary station which has received the station finding message, thereby searching for a device that can communicate. The radio communication apparatus control section 28 has the function of changing the transmission power value by controlling the transmission amplifier 23 or changing the antenna directivity by controlling the antenna control section 24 in accordance with the control information set by a control information setting section 20b of the device body 20.

The finding processing is executed on the basis of the control information set by the control information setting section 20b, thereby a device (subsidiary station) desired by a user can be efficiently searched out. In the reception data processing section 27, the control information set by the control information setting section 20b of the device body 20 is registered. The station finding procedure section 28a refers to this information.

The device body 20 has the functions of a display section 20a and the control information setting section 20b.

The device body 20 is comprised of the main components of an information processing device or the like, i.e., a processor, memory, storage unit, display unit, input unit, and the like. For example, the device body 20 is implemented by a computer designed to load a program recorded on a recording medium such as a CD-ROM, DVD, or magnetic disk and be controlled by the program.

The display section 20a displays information (station finding information) about a device as a subsidiary station searched out by the radio communication apparatus 19 (station finding procedure section 28a).

The control information setting section 20b sets control information that is used to efficiently search for a device (subsidiary station) desired by the user according to the station finding processing executed by the radio communication apparatus 19 (station finding procedure section 28a). In this embodiment, the control information setting section 20b can set a transmission power value, antenna directivity, and station finding procedure time as control information in accordance with an instruction from the user (to be described in detail later).

FIG. 2 is a block diagram showing the detailed arrangements of the antenna control section 24 and antenna 25.

US 7,039,445 B1

5

The antenna control section **24** has the function of changing the antenna directivity under the control of the radio communication apparatus control section **28**, and implements a change in directivity by using an adaptive array antenna. By changing the antenna directivity, the direction in which a station finding message is to be transmitted can be specified. This makes it possible to limit the reachable range of the station finding message.

In the case shown in FIG. **2**, a phase controller **30**, which operates under the control of the radio communication apparatus control section **28**, sets the phases of phase shifters **31a**, **31b**, and **31c** corresponding to three antenna elements **25a**, **25b**, and **25c** to change the radiation characteristics (directivity).

The phase shifters **31a**, **31b**, and **31c** corresponding to the antenna elements **25a**, **25b**, and **25c** are connected to the transmission amplifier **23** and reception amplifier **26** through an adder **32**. The arrangement shown in FIG. **2** includes the three antenna elements **25a**, **25b**, and **25c**. However, the number of antenna elements is not limited to three, and an antenna directivity can be produced as long as a plurality of antenna elements are used.

The basic operation of the communication system of this embodiment will be described first.

As described above, the radio communication apparatus **19** executes radio communication by using, for example, the Bluetooth or HomeRF technique. The Bluetooth and HomeRF techniques and the like use SS (Spread Spectrum) techniques to effectively use limited bands. Of the SS techniques, FH-TDD (Frequency Hopping-Time Division Duplex) (this scheme is the same as that used in Bluetooth) is used.

FIGS. **3** and **4** show a state wherein a station finding procedure is executed.

In general, when a station finding message is to be issued, the unique ID (unique address) of a device as a connection target is unknown. For this reason, as shown in FIG. **3**, the main station **M** transmits a station finding message as a broadcast message that is independent of a device ID.

In this case, as shown in FIG. **4**, the main station consecutively transmits the station finding message while changing the frequency channel at predetermined intervals in accordance with a proper frequency hopping sequence so as to cover all the frequency channels. In this case, since the main station does not obtain information about standby intervals in subsidiary stations, the main station generally transmits the station finding message for a relatively long period of time.

Devices (subsidiary stations **S1** and **S2**) in the standby state monitor this broadcast message while periodically changing standby frequencies in accordance with proper frequency hopping sequences (set in the standby state).

In this state, when the transmission frequency from the main station coincides with the standby frequency at a subsidiary station, the subsidiary station can receive the station finding message from the main station and return a response message in response to the received message.

The response message includes information about the unique ID of the station. This allows the main station to designate the unique subsidiary station (specific device) in the following processing. After the overall station finding procedure is completed, the main station obtains the pieces of unique ID information of all the subsidiary stations set in the standby state within the search range.

The data transmission/reception timing in a case wherein the main station and a plurality of subsidiary stations are searched will be described next with reference to the timing

6

chart of FIG. **5**. Referring to FIG. **5**, a radio communication apparatus (**1**) is mounted in a device serving as a main station, and radio communication apparatuses (**2**), (**3**), and (**4**) are mounted in devices serving as subsidiary stations.

The radio communication apparatus control section **28** of each device holds network information, and determines the timing of data transmission/reception in the radio network on the basis of this network information. In the case of the main station, network information indicates the IDs of all the subsidiary stations in the network and the transmission/reception timing with respect to each subsidiary station. In the case of each subsidiary station, network information indicates the ID of the main station in the network and the transmission/reception timing with respect to the main station.

As shown in FIG. **5**, data communication is performed between the main station and the subsidiary stations by time-division multiplexing. More specifically, in time slot **1**, the radio communication apparatus (**1**) serving as the main station transmits/receives data to/from the radio communication apparatus (**2**) on a one-to-one basis. In time slot **2**, the radio communication apparatus (**1**) transmits/receive data to/from the radio communication apparatus (**3**) in a one-to-one basis. In time slot **3**, the radio communication apparatus (**1**) transmits/receives data to/from the radio communication apparatus (**4**) on a one-to-one basis. Likewise, the radio communication apparatus (**1**) executes data transmission/reception while changing the target radio communication apparatus in units of time slots.

Consider a case wherein a device (subsidiary station) that is designated as a connection target by the user is located at a relatively short distance from the user (main station). Assume that in an office environment, a PC on a desk and a PDA (Personal Digital Assistant) used by the user at the desk are to be connected to each other by radio, and the PC need not be connected to other devices for a while.

Assume that in FIG. **6**, the PC is a main station **M**, and the PDA is a subsidiary station **S1** desired as a connection target by the user. Assume also that the main station **M** need not be connected to nearby subsidiary stations **S2** to **S8**.

In general, if the subsidiary stations **S1** to **S8** exist within the reachable range of the station finding message transmitted from the main station **M** (PC), these stations become search targets, as described above. In this embodiment, however, only a subsidiary station located near the main station **M1** or in a specific direction can be designated as a search target by limiting a search range (the reachable range of the station finding message) by setting control information for limiting the search range in advance.

Control information setting processing for setting control information will be described next with referenced to the flow chart of FIG. **7**.

Control information setting processing is executed by the device body **20** of the device such as a PC serving as a main station. When the user generates a request to execute control information setting processing, the device body **20** starts the control information setting section **20b** to display a control information setting window on the display unit (step **C1**).

In the control information setting window, for example, an instruction to select information to be set (step **C2**). In this embodiment, as control information to be set, for example, a transmission power value and antenna directivity can be arbitrarily designated.

In this case, if a request to set a transmission power value is generated (step **C3**), the control information setting section **20b** displays, for example, the message "Designate a

US 7,039,445 B1

7

distance as a search range”, together with distance choices (selection fields) for the designation of a search range (step C4).

FIG. 8A shows an example of field configuration in which choices for transmission power control are presented. In the case shown in FIG. 8A, as a search range, a distance can be selected from “less than 1 m”, “1 to 10 m”, and “10 to 100 m”.

For example, as shown in FIG. 9, the respective distances as search ranges are set in advance to correspond to the transmission powers required to transmit the station finding message from the radio communication apparatus 19. Assume that the data shown in FIG. 9 are set in the device body 20 in advance.

In the case shown in FIG. 9, if “less than 1 m” is selected as a search range, the station finding message is transmitted with a transmission power of “1 mW”. Likewise, a transmission power of “10 mW” is set for the search range “1 to 10 m”, and a transmission power of “100 W” is set for the search range of “10 to 100 m”.

When, therefore, a device (e.g., a PDA) serving as a subsidiary station is to be connected to a device (e.g., a PC) serving as a main station, the reachable range of a station finding message is limited by designating a search range in accordance with the installation position of the device serving as a subsidiary station, thereby preventing the station finding message from being sent to devices that need not be connected.

In this case, if an instruction to select a distance as a search range from choices is input (step C5), the control information setting section 20b sets a transmission power as control information in accordance with a relationship with search ranges like those shown in FIG. 9 (step C6).

If a request to set an antenna directivity is received in step C3, the control information setting section 20b displays the message “Designate a directivity direction as a search range”, together with directivity direction (angle) choices (selection fields) in which the station finding message for designating a search range is to be transmitted (step C4).

FIG. 8B shows an example of a field configuration in which choices for antenna directivity control are presented. In the case shown in FIG. 8B, as a directivity direction, an angle can be selected from “30° forward”, “180° forward”, and “360°”.

For the respective directivity directions, data are prepared in advance in the antenna control section 24 of the radio communication apparatus 19 to allow the phase controller 30 to set the phase shifters 31a, 31b, and 31c in accordance with a directivity direction.

When, therefore, a device (e.g., a PDA) serving as a subsidiary station is to be connected to a device (e.g., a PC) serving as a main station, the reachable range (angle) of a station finding message is limited by designating a directivity direction range in accordance with the installation direction of the device serving as a subsidiary station, thereby preventing the station finding message from being sent to devices that need not be connected.

In this case, if an instruction to select a directivity direction as a search range from choices is input (step C8), the control information setting section 20b sets data for setting the phase shifters 31a, 31b, and 31c as control information in accordance with the selected directivity direction (step C6).

The control information set by the control information setting section 20b in this manner is transmitted to the radio communication apparatus 19 and registered in the table

8

section 28b of the radio communication apparatus control section 28 through the data interface section 21.

According to the above description, control information is obtained by the control information setting section 20b of the device body 20 in accordance with the search range (distance and directivity direction) designated by the user, and transmitted to the radio communication apparatus 19 (radio communication apparatus control section 28). However, the control information setting section 20b may transmit only data representing the search range designated by the user to the radio communication apparatus control section 28, and the radio communication apparatus control section 28 may convert the data into control information in accordance with the specifications of said self-apparatus (the performance of the transmission amplifier 23 and the number of phase shifters provided for the antenna control section 24) and register the information in the table section 28b.

Station finding processing based on the control information set by control information setting processing will be described next with reference to the flow charts of FIGS. 10 and 11.

FIG. 10 is a flow chart showing station finding processing in the main station. FIG. 11 is a flow chart showing station finding processing in a subsidiary station (see FIG. 4 for the timing of the operation of the main station and subsidiary station).

If an instruction to execute station finding processing is received, the station finding procedure section 28a starts the station finding processing. First of all, the station finding procedure section 28a transmits the unique station finding message set in advance by control operation corresponding to the control information registered in the table section 28b (step A1 in FIG. 10). That is, the station finding procedure section 28a causes the transmission data processing section 22 to transmit the station finding message through the transmission amplifier 23 and antenna control section 24.

If, for example, control information for controlling transmission power is set in the table section 28b, the station finding procedure section 28a controls (amplifies) the transmission amplifier 23 to set the transmission power represented by the control information, thus transmitting the station finding message.

If control information for controlling the directivity direction is set in the table section 28b, the station finding procedure section 28a causes the phase controller 30 of the antenna control section 24 to set the phases of the phase shifters 31a, 31b, and 31c to set the designated directivity direction, thereby producing the directivity of the antenna 25.

The station finding message under control corresponding to control information in this manner is transmitted, thereby connection targets can be limited to only the devices (subsidiary stations) that are present in the search range designated by the user.

Each subsidiary station in the standby state is monitoring the station finding message at predetermined intervals (step B1 in FIG. 11). If the station finding message is not received (step B2), the subsidiary station changes the standby frequency (frequency hopping), and the flow returns to the first step (step B3).

If the station finding message is received in the standby state (step B2), the subsidiary station transmits a response message including the unique ID information of the self-station in response to the station finding message, and is set in the standby state to wait for the message addressed to the unique ID of the self-station (step B4).

US 7,039,445 B1

9

Upon reception of the response message from the subsidiary station for the station finding message (step A2 in FIG. 10), the reception data processing section 27 of the main station identifies the unique ID information included in the response message, and internally registers the unique ID information of the subsidiary station as information representing the subsidiary station as a communication target.

The main station checks whether a timer value associated with the station finding message transmission time indicates a timeout, regardless of whether a response message is received from the subsidiary station (step A4).

If the timer value does not indicate a timeout, the main station changes the frequency channel by frequency hopping in accordance with a proper frequency hopping sequence (step A5), and the flow returns to the first step to transmit the station finding message (step A1). If the timer value indicates a timeout, the station finding procedure is terminated (step A6).

As the above timer value, if a sufficient time for a search for subsidiary stations existing around the main station is ensured, which is not excessively long. The user may change the timeout period as a timer value in accordance with the search range designated by the user. If, for example, the search range is changed from "1 to 10 m", to "less than 1 m" upon designation, the timeout period as a timer value may be shortened.

FIGS. 12 and 13 show how the search range changes by station finding processing based on control information like that described above. FIGS. 12 and 13 show a case wherein the user designates the distance from the main station as a search range, and transmission power control for the station finding message is performed.

As shown in FIGS. 12 and 13, the plurality of subsidiary stations S1 to S8 are present around the main station M. Of the plurality of subsidiary stations S1 to S8, the subsidiary station S1 nearest to the main station M is a subsidiary station designated as a connection target by the user.

In such a state, as shown in FIG. 12, the search range can be limited by designating a short distance from the main station M so as to include only the subsidiary station S1, thereby setting the subsidiary stations S2 to S8 outside the search range.

If no control information is set and no transmission power control is performed, the search range shown in FIG. 13 is set. In the case shown in FIG. 13, subsidiary stations other than the subsidiary stations S4 and S5 are included in the search range.

The main station M therefore receives response messages from many subsidiary stations for the transmitted station finding message. For this reason, the main station M must specify one of the subsidiary stations which have returned the response messages as a connection target.

In contrast to this, if the search range is limited as shown in FIG. 12, the station finding message transmitted from the main station M is received by only the subsidiary station S1. Consequently, the main station M receives the response message from only the subsidiary station S1. This makes it possible to simplify specification of a subsidiary station as a connection target and prevent an excessively long period of time from being spent to find a station.

In the case shown in FIGS. 12 and 13, transmission power control is performed. If, however, antenna directivity control is to be performed, the search range is set to include only a subsidiary station existing within a specific range from the main station.

If, for example, the user designates "30° forward" as a search range, only the subsidiary station S1 becomes a

10

search target as a subsidiary station that exists at a position corresponding to "30° forward" with respect to the main station M. The main station M can therefore receive a response message from only the subsidiary station S1 for the station finding message.

Setting control information in advance by using the control information setting section 20b in accordance with the search range (distance and directivity direction) designated by the user makes it possible to limit the reachable range of the station finding message which is transmitted from the radio communication apparatus 19 mounted in the device serving as the main station to search for a subsidiary station as a connection target.

Subsidiary stations that need not be connected can therefore be excluded in advance. When, for example, a device (PC) which is placed on a table and serves as a main station and a nearby device (PDA) are to be connected to each other, if the search range is narrowed in advance, the main station can be connected to the device (PDA) desired by the user, and other devices that need not be connected are excluded from the station finding procedure, thus preventing an excessively long period of time from being spent to find a station.

When a subsidiary station to be connected is selected from a plurality of subsidiary stations that have been searched out, since subsidiary stations that need not be connected are excluded in advance, the user can easily select a subsidiary station serving as a connection target, thus improving operability.

In addition, as the transmission power used to transmit the station finding message can be minimized, a reduction in power consumption can be attained.

According to the above description, the search range is limited in accordance with the distance from the main station or antenna directivity designated by the user. However, the search range can be determined in the following manner.

In searching for a subsidiary station as a connection target by station finding processing, the station finding message is transmitted, and a corresponding response message is received to acquire information (e.g., the unique ID information) of the subsidiary station.

The station finding procedure (protocol) needs to be variously operated to prevent collision between response messages returned from a plurality of subsidiary stations upon transmission of a station finding message to all subsidiary stations existing in the search range.

In general, as the search range extends, the number of subsidiary stations included in the search range increases. As a consequence, a longer time is required for the station finding procedure. Assume that as the search range is widened by one step (e.g., from "less than 1 m" to "1 to 10 m"), the number of subsidiary stations newly included in the search range increases. In this case, since the station finding procedure must be variously operated for each subsidiary station, the time required for the station finding procedure abruptly increases.

In the control information setting processing executed by the control information setting section 20b of the device body 20, therefore, the user designates a station finding procedure time as a search range.

In this case, the control information setting section 20b displays, for example, the message "Designate a station finding procedure time", together with station finding procedure time choices (selection fields) for the designation of a search range. As the station finding procedure time choices, "1 second", "5 seconds", "10 seconds", and the like are displayed.

US 7,039,445 B1

11

If the station finding procedure time choices, a table for linking transmission power values to station finding procedure times, like the one shown in FIG. 14, is prepared in advance. The control information setting section 20b sets, as control information, a transmission power value corresponding to the station finding procedure time designated by the user in accordance with the contents set in this table, and transmits it to the radio communication apparatus 19.

The radio communication apparatus 19 transmits the station finding message with an output corresponding to the transmission power value corresponding to the control information set by the control information setting section 20b (the details of this operation are the same as those in the station finding procedure for the case of transmission power control described with reference to FIGS. 11 and 12).

This operation makes it possible to prevent the station finding message from reaching at least subsidiary stations existing outside the search range corresponding to the time designated by the user.

If the search range narrows, the number of subsidiary stations existing in the search range may decrease. When, however, many subsidiary stations are present only near the main station, the number of subsidiary stations that can receive the station finding message may not greatly change even if the search range is narrowed. In such a special case, the time required for the station finding procedure for each subsidiary station remains the same.

The control information setting section 20b therefore may output a designated station finding procedure time itself as control information to the radio communication apparatus 19 as well as setting a search range by setting a transmission power value in accordance with the station finding procedure time designated by the user.

In this case, the radio communication apparatus control section 28 of the radio communication apparatus 19 transmits the station finding message in accordance with the transmission power value, and monitors the time that has elapsed since the start of the transmission of the station finding message to determine whether the station finding message has reached within the station finding procedure time set as the control information.

If the station finding message has reached within the station finding procedure time, the transmission of the station finding message is forcibly stopped, and the station finding processing is terminated. This makes it possible to complete the station finding procedure within the station finding procedure time designated by the user.

The above case is a special case. In general, even if the station finding procedure is terminated within the station finding procedure time, the subsidiary station designated as a connection target by the user is registered as long as the station finding procedure is completed between the main station and all the subsidiary stations existing in the search range within the station finding procedure time. In addition, even if the station finding procedure for all the subsidiary stations is not complete, there is a good possibility that the subsidiary station designated as a connection target by the user is registered (because the user designates a station finding procedure time as circumstances demand).

Since a search range can be set by designating a station finding procedure time in this manner, an optimal station finding procedure conforming to a request from the user, i.e., a station finding procedure optimized to prevent an excessively long period of time from being spent to register a subsidiary station (device) as a connection target, can be executed. This makes it possible to efficiently search for a station that needs to be connected.

12

In the control information setting processing described with reference to the flow chart of FIG. 7, the distance from the main station (transmission power control) or antenna directivity can be arbitrarily designated by the user. However, such information including the above station finding procedure time may be arbitrarily designated.

Another method for a station finding procedure will be described next with reference to the flow chart of FIG. 15. Steps D1 to D3 and D6 to D8 in the flow chart of FIG. 15 respectively correspond to steps A1 to A3 and A4 to A6 in the flow chart of FIG. 10, and the same processing is executed in these steps. Hence, a detailed description of these steps will be omitted.

In the station finding procedure described above, when a station finding message is transmitted, and response messages from subsidiary stations existing in the search range for the station finding message are received, all the pieces of unique ID information of the subsidiary stations, contained in the respective response messages, are sequentially registered.

If, however, the station finding procedure is terminated when registration about the subsidiary station (device) designated as a connection target by the user is complete, the time required for the processing can be further shortened.

In the station finding procedure, when the unique ID information of a subsidiary station, contained in a response message received from the subsidiary station, is registered (step D3), the station finding procedure section 28a notifies the device body 20 of its unique ID information, as shown in the flow chart of FIG. 15.

The display section 20a in the device body 20 displays station finding information on the basis of the unique ID information of the subsidiary station, acquired from the response message by the radio communication apparatus 19 (step D4).

If, for example, the station finding information is a device address, the display section 20a displays information that can be acquired from the received response message, as shown in FIG. 16A.

In the case shown in FIG. 16A, device numbers starting from "1" are sequentially assigned in the order in which the devices are searched out, and device addresses, e.g., "A39B31", are displayed in correspondence with the device numbers.

In this manner, the display section 20a sequentially displays pieces of station finding information (device addresses) while assigning the device numbers "2", "3", . . . every time a response message for the station finding message is received from a subsidiary station, i.e., a subsidiary station can be searched out.

If, therefore, the user remembers the device address of a device as a connection target, the user of the main station can know in real time that the desired device is searched out by the station finding procedure.

Even if the user does not remember the device address of a device as a connection target, since a character at a predetermined digit position of the device address generally indicates the type of device, the user of the main station can determine on the basis of the character whether the desired device is searched out.

The display section 20a displays the station finding information about the subsidiary station that has been searched out, and accepts an instruction to interrupt the station finding procedure executed by the station finding procedure section 28a.

When, therefore, the user confirms, on the basis of the station finding information displayed during the station

US 7,039,445 B1

13

finding procedure, that the search for the desired device is complete, the user of the main station can generate an instruction to interrupt the station finding procedure.

Upon reception of the instruction to interrupt the station finding procedure, the device body 20 notifies the radio communication apparatus control section 28 in the radio communication apparatus 19 of the instruction. The station finding procedure section 28a of the radio communication apparatus control section 28 then terminates the station finding procedure in accordance with the notification from the device body 20 (steps D5 and D8).

In this manner, if the user knows information about a subsidiary station as a connection target in advance, information (station finding information) about a subsidiary station acquired by the station finding procedure is sequentially displayed to notify the user of the information so as to interrupt the station finding procedure in accordance with a notification from the user, thus saving an unnecessary time for the station finding procedure. This scheme allows more efficient station finding if a scheme of widening the reachable range of the station finding message stepwise is used, in particular.

As an example of displaying station finding information, FIG. 16A shows an example of displaying only device addresses. However, as shown in FIG. 16B, name information about a device as a connection target may be acquired and displayed to notify the user of a found device so as to allow the user of the main station to easily recognize it.

In the case shown in FIG. 16B, device classifications ("PC", "printer", and the like) and device names ("Luna", "Apolon", and the like) are displayed in correspondence with the device numbers.

Since a character at a predetermined digit position of each device address represents the type of a device, device classifications can be discriminated and displayed on the basis of such characters.

The device names are acquired by performing procedures such as device connection (Paging procedure) and name request command procedure (a service by Link Manager).

The device connection procedure and name request command procedure described above may be omitted by storing device name information acquired in the past, together with device addresses, and acquiring the stored device name information on the basis of the device address acquired by the station finding procedure.

If various pieces of information about a device set as a connection target can be independently registered as well as the device name, the user can be notified of the found device so as to more easily recognize it by displaying these pieces of information together with the device name.

By displaying other information such as a device name in this manner instead of displaying only a device address, the user can be notified of a device as a connection target so as to more easily recognize it.

In the arrangement shown in FIG. 1, the functions implemented by the display section 20a and control information setting section 20b are provided for the device body 20. However, these functions may be provided for the radio communication apparatus 19.

The techniques in the station finding procedure described in the above embodiment can be stored as computer-executable programs in a storage medium such as a magnetic disk (e.g., a floppy disk or hard disk), an optical disk (e.g., a CD-ROM or DVD), or a semiconductor memory and can be provided for various apparatuses. These programs can also be transmitted and provided for various apparatuses through communication media. A computer for implementing this

14

apparatus loads a program recorded on a recording medium or receives it through a communication medium, and the operation of the computer is controlled by the program, thereby executing the above processing.

As has been described above, according to the present invention, the reachable range of the station finding message is changed in searching for a station as a connection target so as to efficiently perform a station finding procedure in a short period of time. In addition, since stations that need not be connected are excluded, a station as a connection target can be efficiently designated from stations that can be searched out afterward. This makes it possible to implement a station finding procedure with high operability for the user.

Additional advantages and modifications will readily occur to those skilled in the art. Therefore, the invention in its broader aspects is not limited to the specific details and representative embodiments shown and described herein. Accordingly, various modifications may be made without departing from the spirit or scope of the general inventive concept as defined by the appended claims and their equivalents.

What is claimed is:

1. A communication system comprising a first device and a second device for communicating with the first device through a wireless link,

the first device including:

a section which sets a range for a message transmitted from the first device, wherein the message is for searching for the second device to be communicated with the first device, and

a section which causes the first device to transmit a message in accordance with the range set by said setting section, wherein the range set by said setting section is a directivity of the message transmitted from the first device,

the second device including:

a section which sets the message, and
a section which responds to the message from the first device so as to set the wireless link.

2. A system according to claim 1, wherein the range which is set by said setting section is a distance from the first device.

3. A communication method for setting a wireless link between a first device and a second device, comprising:

setting a range for a message transmitted from the first device, wherein the message is for searching for the second device to be communicated with the first device;

causing the first device to transmit a message in accordance with the set range, wherein the range set by said setting step is a directivity of the message transmitted from the first device;

receiving the message from the first device and outputting a response with respect to the received message from the second device; and

setting the wireless link between the first device and second device based on the response.

4. A method according to claim 3, wherein the range which is set by said setting step is a distance from the first device.

5. A communication apparatus comprising:

a section which sets a range for a message, wherein the message is for searching for another device to be communicated with the apparatus through a wireless link; and

a section which transmits the message in accordance with the set range by said setting section;

US 7,039,445 B1

15

wherein said setting section inputs a direction from the apparatus as a range, and said message transmission section includes a section for changing a direction in which the message is transmitted, and controls said changing section in accordance with the direction set by said setting section so as to transmit the message.

6. An apparatus according to claim 5, wherein said setting section inputs a distance from the self-apparatus as a range for the message, and

said message transmission section transmits a message with a transmission power value corresponding to the distance input by said setting section.

7. An apparatus according to claim 5, wherein said setting section comprises a section for inputting a time during which transmission of the message continues, and

said message transmission section transmits the message only for the time input by said setting section.

8. An apparatus according to claim 5, further comprising: a section for sequentially displaying information acquired by the response message from the another apparatus every time the response message is received; and a section for terminating transmission of the message when an instruction to interrupt the transmission of the message is input in accordance with the information displayed by said display section.

9. A communication system having a first device and a second device for communicating with the first device through a wireless link, comprising:

a first device which transmits a message for searching for the second device by radio communication, wherein the first device comprises:

a main body which sets a range for the message transmitted from the first device and which outputs first control information in accordance with the set range;

a controller, connected to the main body via a data interface section, which receives the first control information from the main body and which outputs second control information based on the received first control information;

a transmission amplifier, connected to the controller, which amplifies the message based on the second control information and which transmits the amplified message to an antenna so as to transmit the message in accordance with the range set by the main body; and an antenna control section, connected to the controller and the antenna, which controls an antenna directivity of the antenna based on the second control information output from the controller so as to transmit the message in accordance with the range set by the main body.

10. A communication system according to claim 9, wherein the range set by the main body indicates a distance from the first device.

11. A communication system according to claim 9, wherein the range set by the main body indicates a directivity of the message transmitted from the first device.

12. A communication system according to claim 9, wherein the controller has a table which stores the first control information output from the main body and the controller outputs the first control information to one of the transmission amplifier and antenna control section.

13. A communication method for setting a wireless link between a first device and a second device, comprising the steps of:

setting a range for a message transmitted from the first device in a main body of the first device and outputting first control information in accordance with the set

16

range from the main body, wherein the message is for searching for the second device;

receiving the first control information from the main body in a controller connected to the main body via a data interface, and outputting second control information based on the received first control information from the controller; and

controlling one of a transmission amplifier, connected to the controller, which amplifies the message based on the second control information and which transmits the amplified message to an antenna and an antenna control section, connected to the controller and the antenna, which controls an antenna directivity of the antenna based on the second control information output from the controller.

14. A communication apparatus comprising:

a main body which sets a range for a message transmitted from the communication apparatus and which outputs control information in accordance with the set range, wherein the message is for searching for a device as a connection target by radio communication;

a controller, connected to the main body via a data interface section, which receives the first control information from the main body and which outputs second control information based on the received first control information;

a transmission amplifier, connected to the controller, which amplifies the message based on the second control information and which transmits the amplified message to an antenna so as to transmit the message in accordance with the range set by the main body; and

an antenna control section, connected to the controller and the antenna, which controls an antenna directivity of the antenna based on the second control information output from the controller so as to transmit the message in accordance with the range set by the main body.

15. A communication apparatus according to claim 14, wherein the range set by the main body indicates a distance from the communication apparatus.

16. A communication apparatus according to claim 14, wherein the range set by the main body indicates a directivity of the message transmitted from the communication apparatus.

17. A communication apparatus according to claim 14, wherein the controller has a table which stores the first control information output from the main body and the controller outputs the first control information to one of the transmission amplifier and antenna control section.

18. A communication system having a first device and a second device for communicating with the first device through a wireless link, comprising:

the first device including;

a first outputting section for outputting a message to a first range in which the second device and an external device are positioned,

a second outputting section for outputting the message to a second range in which the second device is positioned, the external device positioning out of the second range, wherein the second range represents a directivity of the message transmitted from the first device, and

a section which selects one of the first outputting section and the second outputting section,

US 7,039,445 B1

17

the second device including;
a section which receives the message, and a section which responds to the message from the first device so as to set the wireless link.

19. A communication system according to claim 18, 5
wherein the second range represents a distance from the first device.

20. A communication device for communicating with an external device through a wireless link, comprising:

- a first outputting section which outputs a message to a first 10
range in relation to a position of the external device, the message being used to set the wireless link, wherein the first range represents a directivity of the message transmitted from the communication device;
- a second outputting section which outputs the message to 15
a second range different from the first range; and
- a section which selects one of the first outputting section and the second outputting section.

21. A communication device according to claim 20, 20
wherein the first range represents a distance from the communication device.

22. A method for setting a wireless link between a first device and a second device, comprising the steps of:
determining one of a first range and a second range in relation to the position of the second device;

18

outputting a message from the first device to one of the first range and second range determined, wherein the first range represents a distance from the first device and the second range represents a directivity of the message transmitted from the first device;

receiving a response to the message, from the device; and setting the wireless link on the basis of the response.

23. A communication system comprising a first device and a second device for communicating with the first device through a wireless link,

the first device including:

- a section which sets a user-designated search range for a message transmitted from the first device, wherein the message is for searching for the second device to be communicated by the first device, and
- a section which causes the first device to transmit a message in accordance with the range set by said setting section,

the second device including:

- a section which sets the message, and
- a section which responds to the message from the first device so as to set the wireless link.

* * * * *

EXHIBIT 6

TP-Link WiFi Routers w/ Beamforming



AC1900 Wireless MU-MIMO Gigabit Router

Archer C90

- **802.11ac Wave2 WiFi** – 1300 Mbps on the 5 GHz band and 600 Mbps on the 2.4 GHz band*
- **MU-MIMO Technology** – Three simultaneous data streams help your devices achieve optimal performance by making communication more efficient**
- **Boosted WiFi Coverage** – Beamforming technology delivers a highly efficient wireless connection*
- **Advanced Security** – Advanced features like Parental Controls, Guest Network and Access Control provide advanced security for your WiFi

13. A communication method for setting a wireless link between a first device and a second device, comprising the steps of:

setting a range for a message transmitted from the first device in a main body of the first device and outputting first control information in accordance with the set range from the main body, wherein the message is for searching for the second device;

receiving the first control information from the main body in a controller connected to the main body via a data interface, and outputting second control information based on the received first control information from the controller; and

controlling one of a transmission amplifier, connected to the controller, which amplifies the message based on the second control information and which transmits the amplified message to an antenna and an antenna control section, connected to the controller and the antenna, which controls an antenna directivity of the antenna based on the second control information output from the controller.

Claim 13

A communication method for setting a wireless link between a first device and a second device, comprising:

Source: <https://www.TP-Link.com/us/home-networking/wifi-router/archer-c90/>



Strong Signal. Great Coverage.

Three external antennas and one internal antenna transmit WiFi signals to every corner of your home. Beamforming technology detects devices, even if they are far away or low-powered, and concentrates wireless signal strength towards them.

Claim 13	
<p>setting a range for a message transmitted from the first device in a main body of the first device and outputting first control information in accordance with the set range from the main body, wherein the message is for searching for the second device;</p>	<p>Source: https://www.TP-Link.com/ar/support/faq/2291/</p> <p>Q2: What's the range of an 11AC wireless product or how far can it cover?</p> <p>A2: Same as 11N product, range of 11AC will be influenced by kinds of environmental interferences. Relatively speaking, 11AC signal is less powerful than 2.4GHz to when it has to deal with walls or obstacle alike.</p> <p>Under unknown environmental factors, range of 2.4GHz is about 20 meters while 5GHz should be within 15 meters to guarantee a good networking experience.</p> <p>We can adjust the location of the router or angle of antennas to increase Wi-Fi range. And choosing a least used channel based on scanning result of wireless networks nearby is also recommended.</p> <p>Note:</p> <ol style="list-style-type: none">1. For portable product, such as Mi-Fi M7350/M5350 or TL-WR710N/TL-WR702N, range is about 10 meters.2. Range of high power product, such as TL-WR841HP, is generally better than standard product like TL-WR841N and specific range is published on official website.3. Product equipped with internal antennas has shorter range than standard one, but not too much. For example, compared with C20, C20i's range is a little bit shorter.4. Beamforming feature makes product such as C3200 has better range than those 11AC product without Beamforming in terms of 5GHz.

Claim 13

Source: <https://community.cisco.com/t5/wireless-mobility-documents/the-significance-of-beacon-frames-and-how-to-configure-the/ta-p/3132525>

setting a range for a message transmitted from the first device in a main body of the first device and outputting first control information in accordance with the set range from the main body, wherein the message is for searching for the second device;

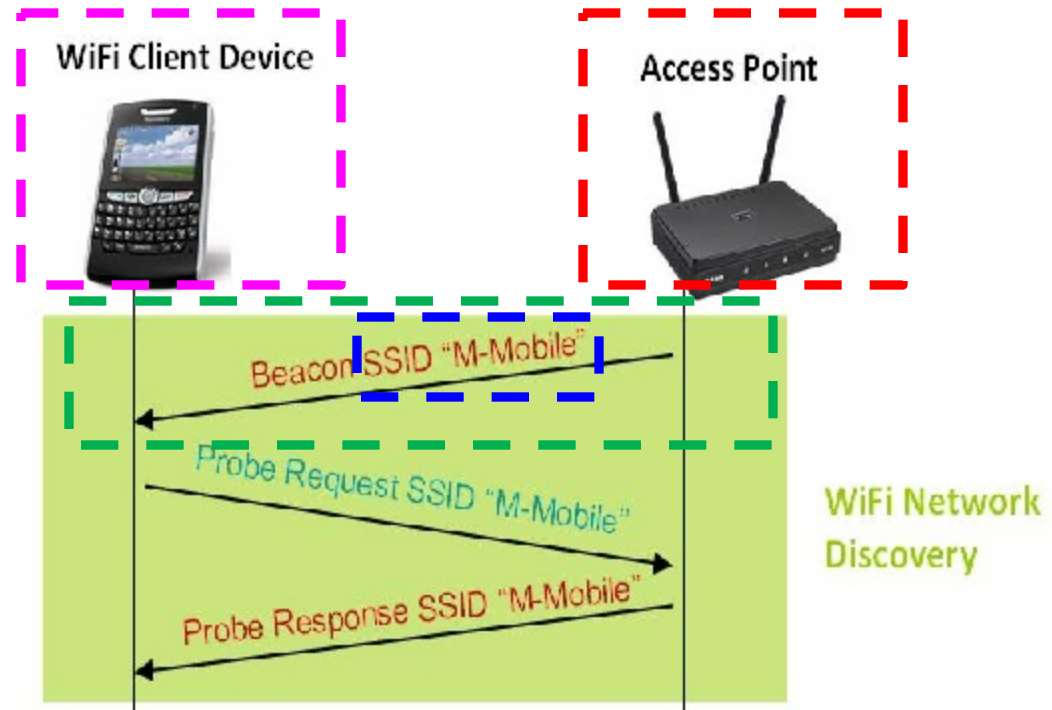

Claim 13

receiving the first control information from the main body in a controller connected to the main body via a data interface, and outputting second control information based on the received first control information from the controller; and

Source: <https://www.microcontrollertips.com/teardown-inside-TP-Link-archer-c7-wireless-router/>

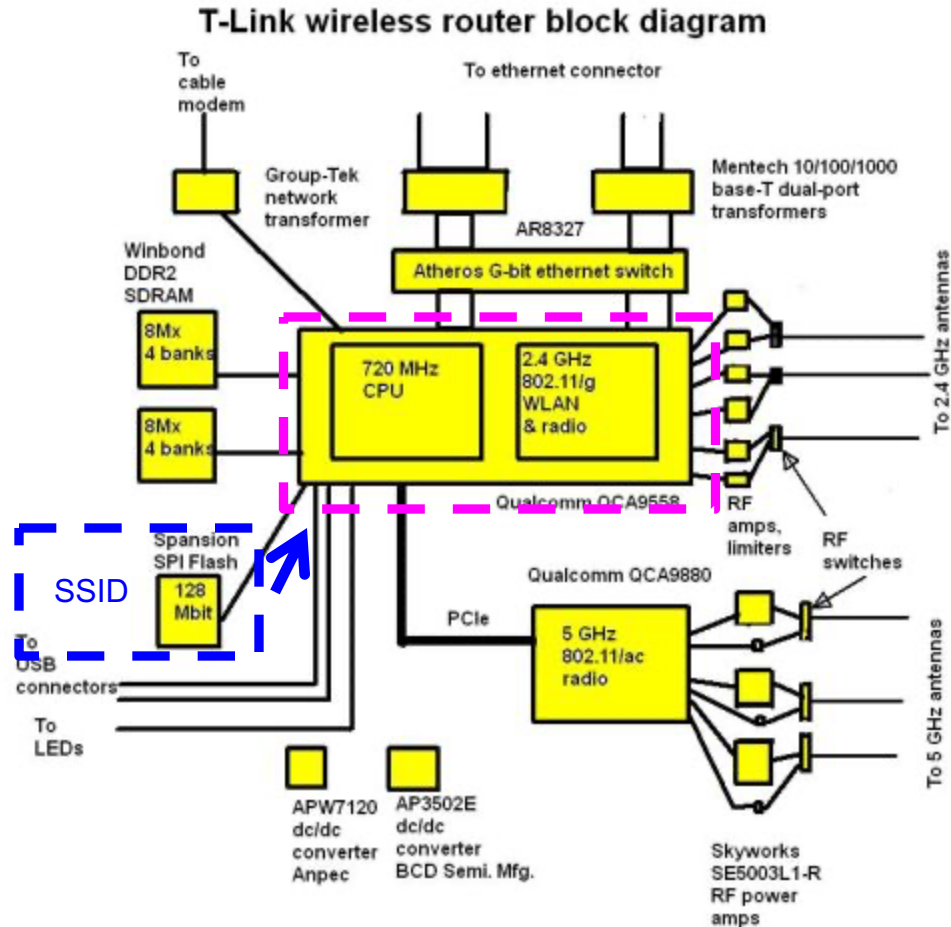

Claim 13

receiving the first control information from the main body in a controller connected to the main body via a data interface, and outputting second control information based on the received first control information from the controller; and

Source: <https://www.rfwireless-world.com/Terminology/Analog-Beamforming-vs-Digital-Beamforming.html>

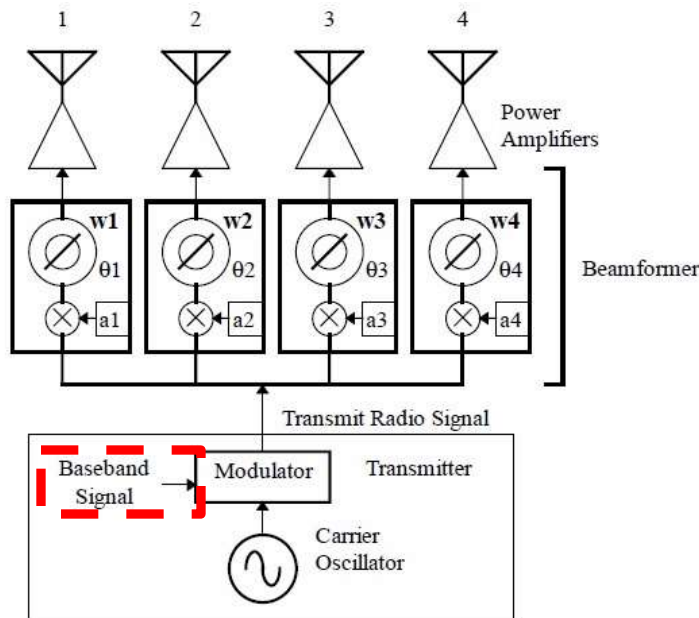

Source: <https://www.microcontrollertips.com/teardown-inside-TP-Link-archer-c7-wireless-router/>

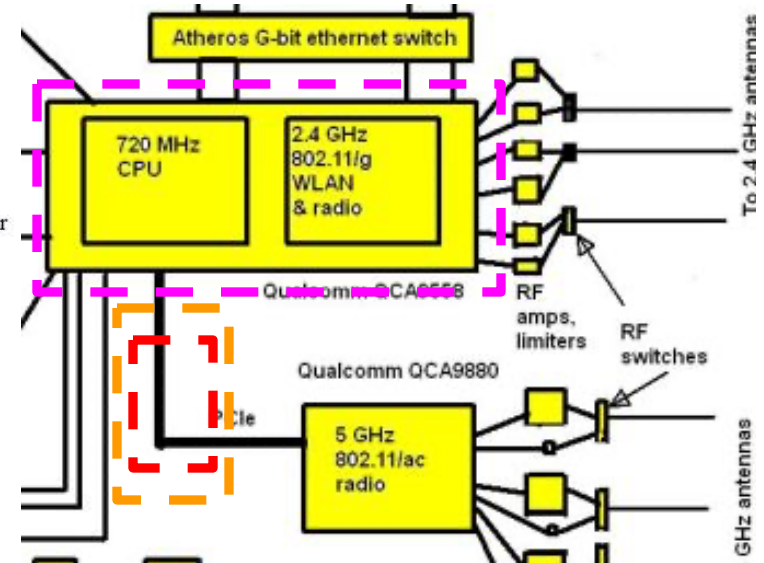

Claim 13

controlling one of a transmission amplifier, connected to the controller, which amplifies the message based on the second control information and which transmits the amplified message to an antenna and an antenna control section, connected to the controller and the antenna

Source: <https://www.rfwireless-world.com/Terminology/Analog-Beamforming-vs-Digital-Beamforming.html>

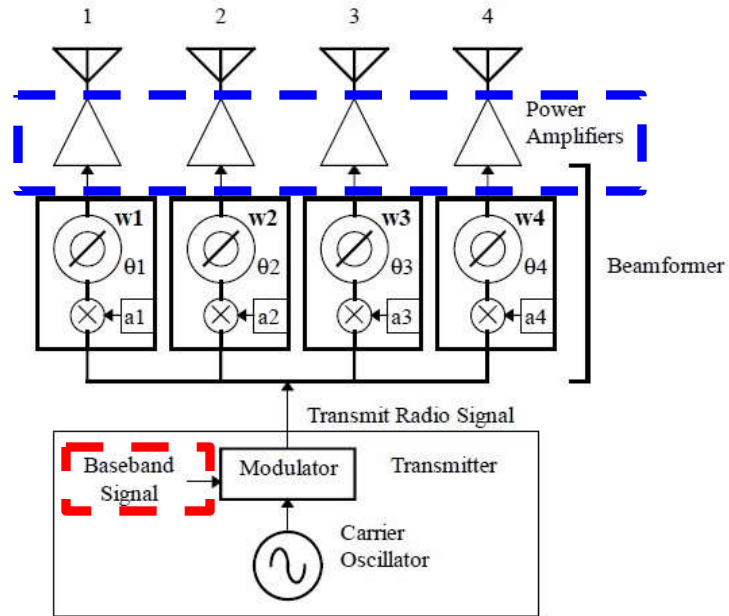

Claim 13

controlling one of a transmission amplifier, connected to the controller, which amplifies the message based on the second control information and which transmits the amplified message to an antenna and an antenna control section, connected to the controller and the antenna

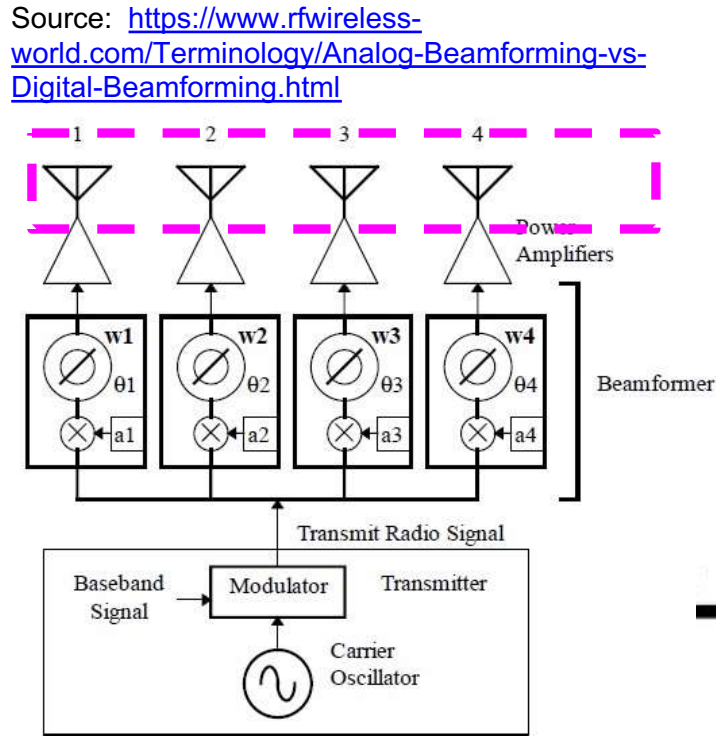

Source: <https://www.microcontrollertips.com/teardown-inside-TP-Link-archer-c7-wireless-router/>

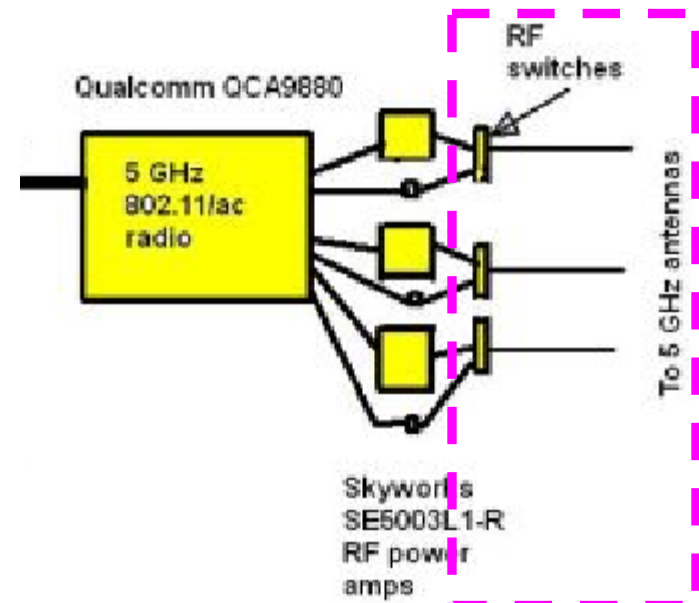

Claim 13

which controls an antenna directivity of the antenna based on the second control information output from the controller.

Source: <https://www.TP-Link.com/us/support/faq/2096/>

What is TP-Link EAP Beamforming?

Q&A of functional explanation or specification parameters

Updated 02-13-2018 08:53:19 AM 15608

This Article Applies to: ♥

Beamforming is a signal processing technique. In simple words, it can locate the Wi-Fi devices and then strengthen the signal in the specific direction from AP to client.

With Omni antenna, AP broadcasts Wi-Fi signal in all directions, which means no matter where your Wi-Fi devices are located, they all receive the signal with similar strength in same distance.

With Beamforming technology, the AP will locate the Wi-Fi devices and then strengthen the signal in that direction, extending Wi-Fi coverage, reducing unnecessary RF interference and creating a stronger, faster and more reliable wireless communication.



(1) Without Beamforming



(2) Beamforming

minis

Claim 13

which controls an antenna directivity of the antenna based on the second control information output from the controller.

Source: <https://www.rfwireless-world.com/Terminology/Analog-Beamforming-vs-Digital-Beamforming.html>

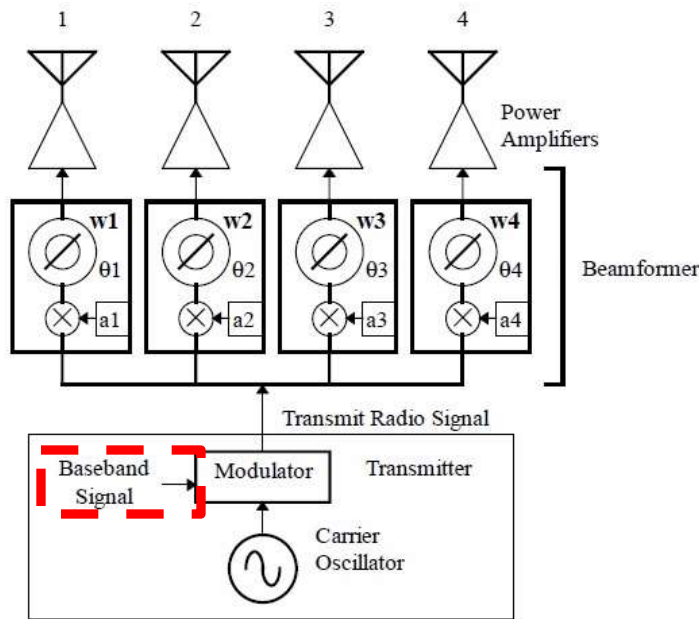

Source: <https://www.microcontrollertips.com/teardo-wn-inside-TP-Link-archer-c7-wireless-router/>

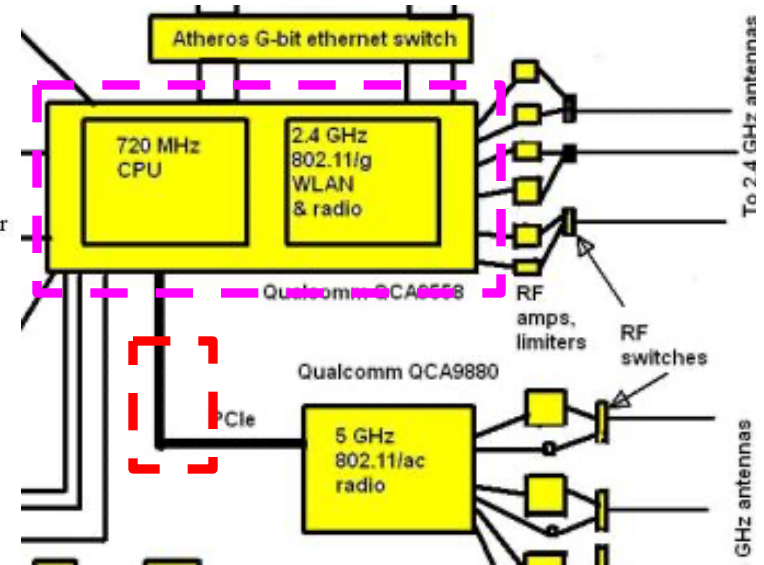

EXHIBIT 7



US007127210B2

(12) **United States Patent**
Aoyagi

(10) **Patent No.:** **US 7,127,210 B2**
 (45) **Date of Patent:** **Oct. 24, 2006**

(54) **WIRELESS COMMUNICATION APPARATUS**

(75) Inventor: **Kazunori Aoyagi**, Fussa (JP)

(73) Assignee: **Kabushiki Kaisha Toshiba**, Tokyo (JP)

(*) Notice: Subject to any disclaimer, the term of this patent is extended or adjusted under 35 U.S.C. 154(b) by 576 days.

(21) Appl. No.: **10/096,678**

(22) Filed: **Mar. 14, 2002**

(65) **Prior Publication Data**

US 2003/0114107 A1 Jun. 19, 2003

(30) **Foreign Application Priority Data**

Sep. 20, 2001 (JP) 2001-287376

(51) **Int. Cl.**
H04B 7/00 (2006.01)

(52) **U.S. Cl.** **455/41.2; 455/403; 455/417; 370/259; 370/260; 370/261**

(58) **Field of Classification Search** 455/403, 455/450, 410, 41.2, 41.3, 416, 417; 370/259, 370/260, 261, 262, 263, 264, 265, 266, 267, 370/268, 269, 270

See application file for complete search history.

(56) **References Cited**

U.S. PATENT DOCUMENTS

2002/0164953 A1* 11/2002 Curtis 455/41
 2003/0054794 A1* 3/2003 Zhang 455/403

FOREIGN PATENT DOCUMENTS

JP 2000-209646 7/2000
 JP 2001-189974 7/2001
 JP 2000-018082 1/2002

* cited by examiner

Primary Examiner—Matthew D. Anderson

Assistant Examiner—Sanh Phu

(74) *Attorney, Agent, or Firm*—Finnegan, Henderson, Farabow, Garrett & Dunner, L.L.P.

(57) **ABSTRACT**

This invention relates to a wireless communication apparatus including a discovery unit which discovers the completion of connection with another wireless communication apparatus, a mode setup unit which sets up a mode which defines processing for a signal for performing communication with the wireless communication apparatus from a wireless communication apparatus except for another wireless communication apparatus, and a shift unit which shifts to the mode set up by the mode setup unit when the discovery unit discovers the completion of connection.

21 Claims, 5 Drawing Sheets

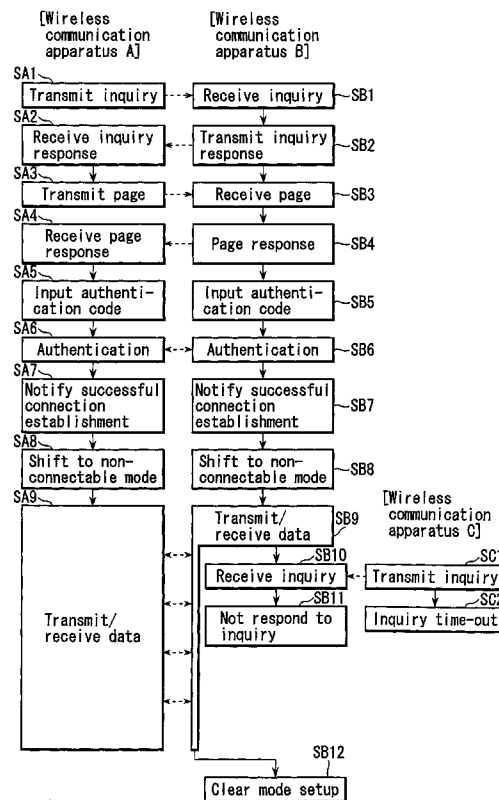

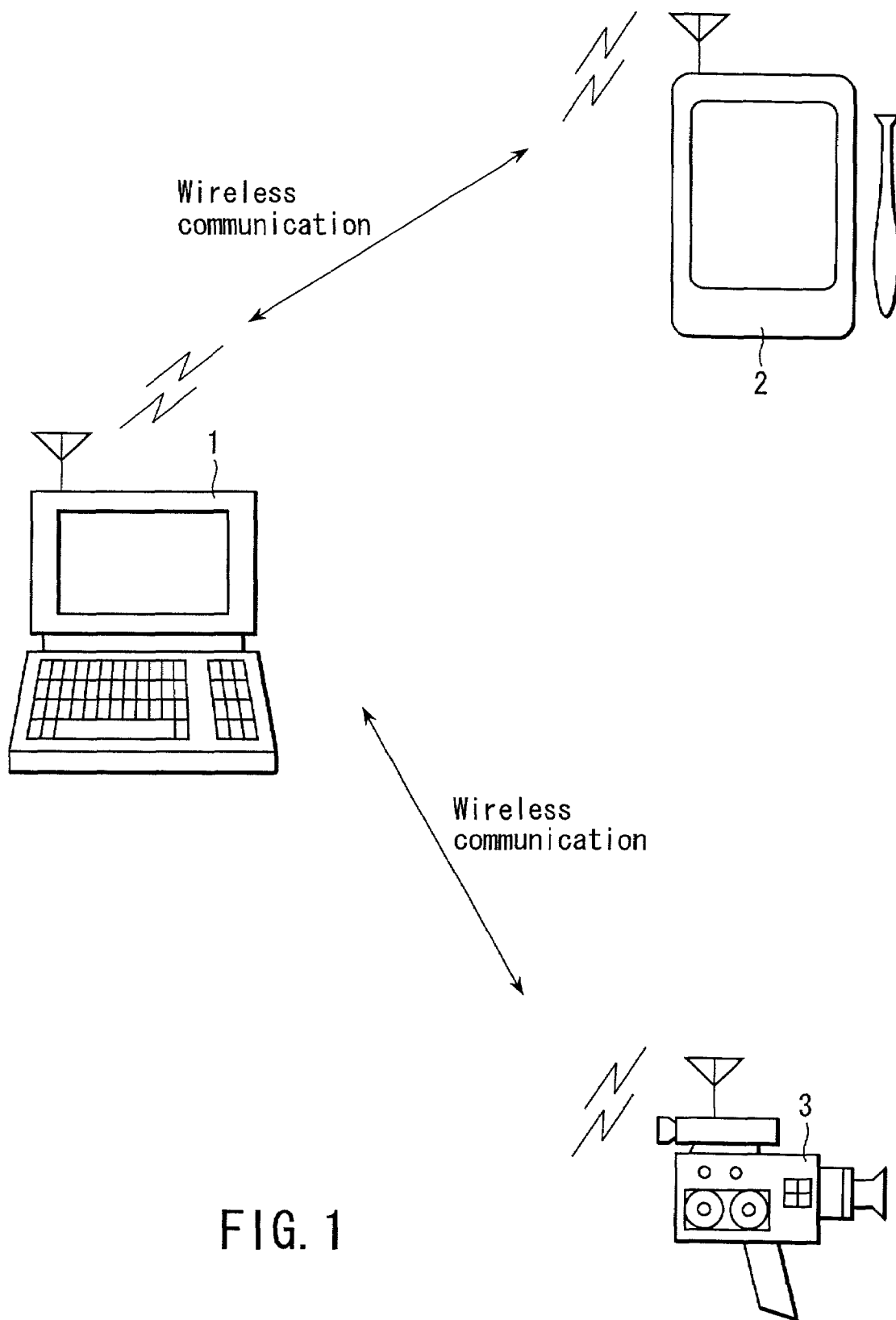

FIG. 1

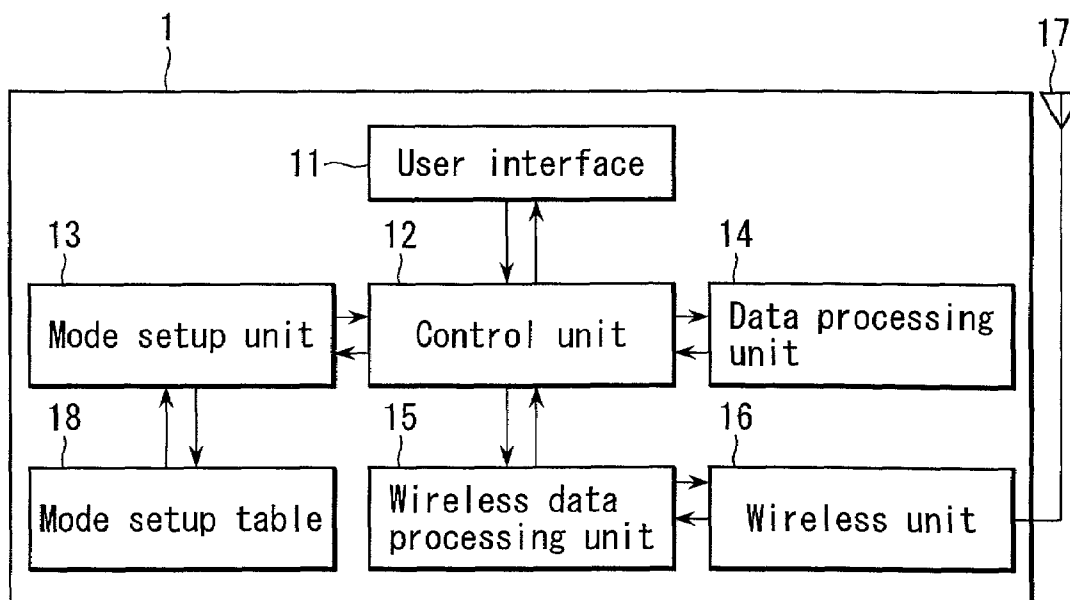

FIG. 2

Unique address	Mode selected upon connection establishment
Unique address A	Non-connectable mode 1
Unique address B	Non-discoverable mode
Unique address C	Non-connectable mode 2
Unique address D	Non-discoverable mode
Unique address E	Non-connectable mode 1
:	:

FIG. 3

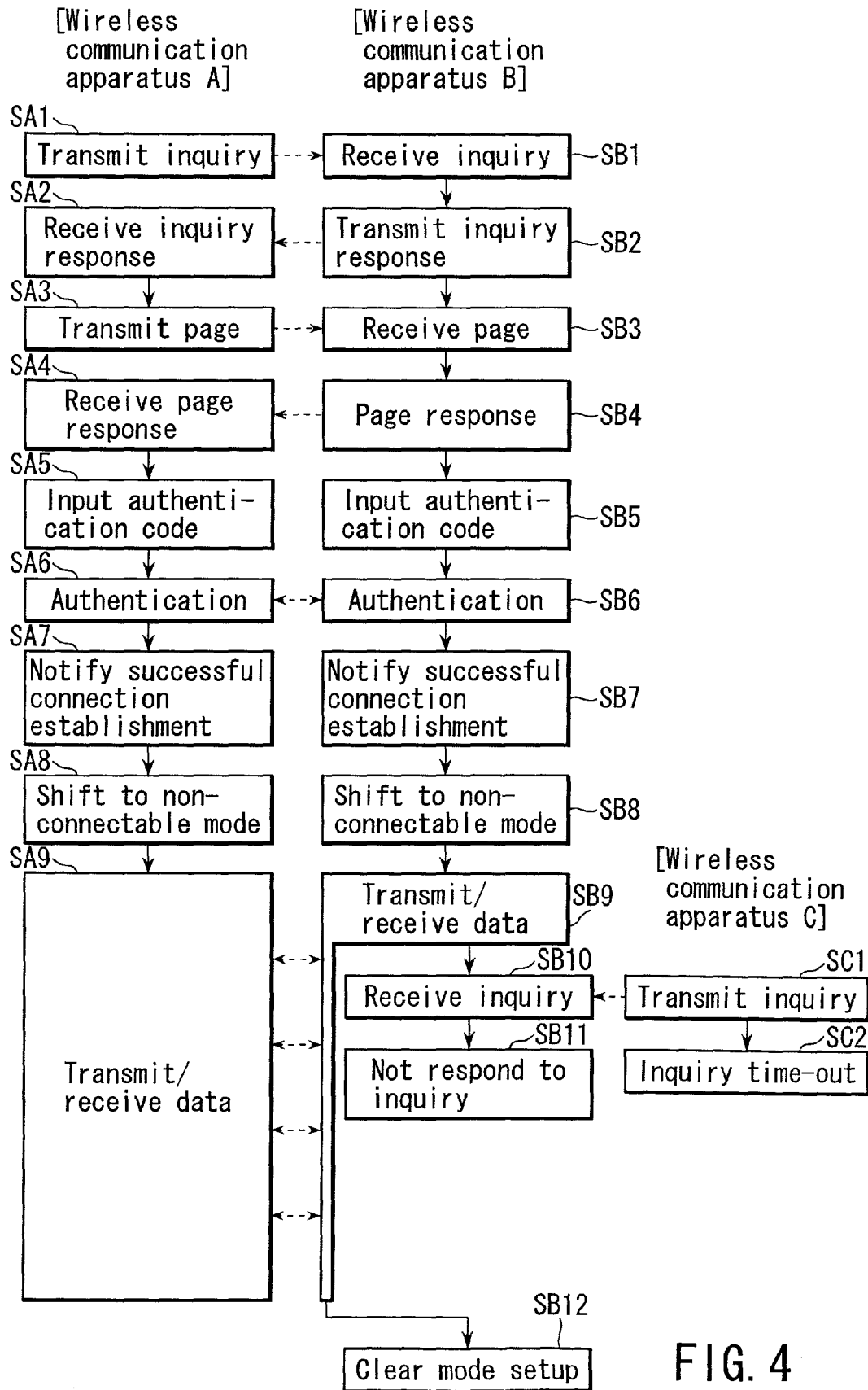

FIG. 4

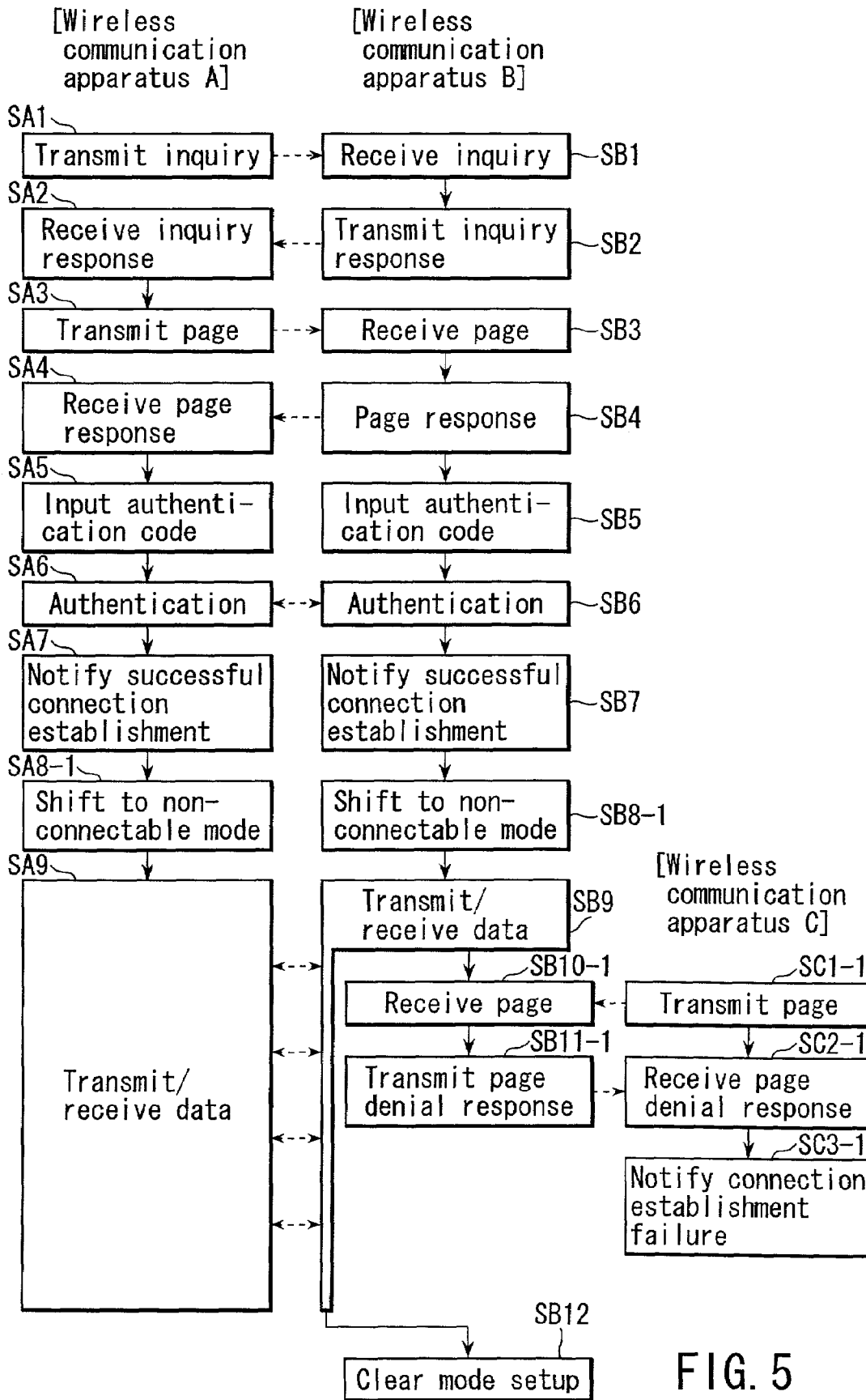

FIG. 5

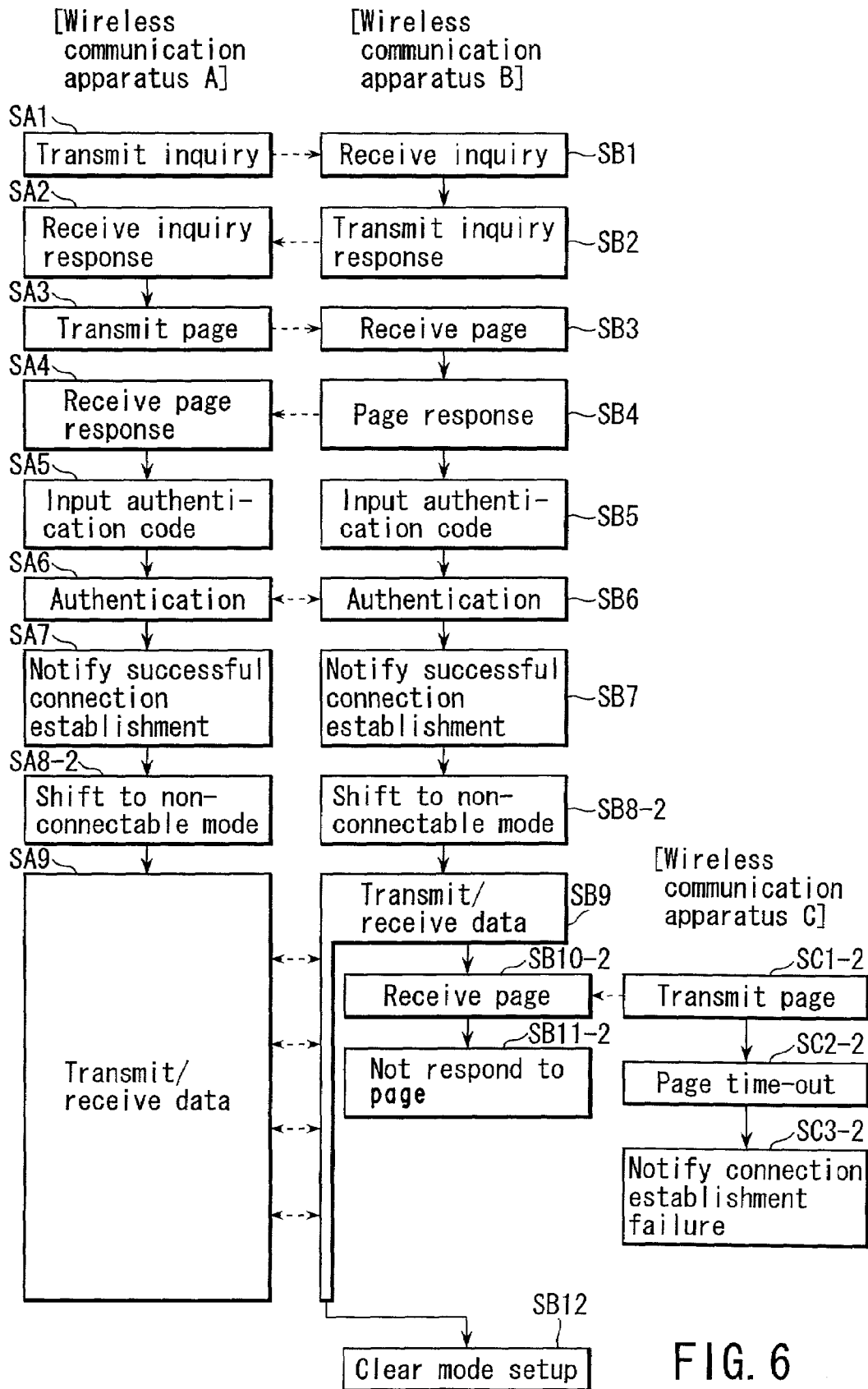

FIG. 6

US 7,127,210 B2

1

WIRELESS COMMUNICATION APPARATUSCROSS-REFERENCE TO RELATED
APPLICATIONS

This application is based upon and claims the benefit of priority from the prior Japanese Patent Application No. 2001-287376, filed Sep. 20, 2001, the entire contents of which are incorporated herein by reference.

BACKGROUND OF THE INVENTION

1. Field of the Invention

The present invention relates to a wireless communication apparatus and, more particularly, to a wireless communication apparatus which, after establishing connection with another wireless communication apparatus, automatically changes setups for discovery or connection with respect to still another wireless communication apparatus except for the connected wireless communication apparatus.

2. Description of the Related Art

The Bluetooth technique capable of achieving short-distance wireless communication between a plurality of wireless communication apparatuses has recently been developed along with the development of the wireless communication technology. An example of techniques adopting the Bluetooth technique is Jpn. Pat. Appln. KOKAI Publication No. 2001-189974.

Regarding the process up to establishing connection between wireless communication apparatuses in Bluetooth which is one of wireless communication schemes, the prior art reads,

“To communicate with another device, a given device makes an inquiry to check whether a device equipped with Bluetooth exists in a range where its radio waves can reach. The device checks an inquiry from another device by inquiry scan, and responds to the inquiry by an inquiry response function. The device can know the 48-bit address of the partner through an inquiry response which transmits an FHS (Frequency Hopping Synchronization) packet. Connection is set between these devices by the address. The paging device which wants to set connection starts a page process by using a specific address. At this time, the paged device periodically performs page scan. Since the normal page period is longer than the page scan period, the paged device can set connection with the paging device. Upon recognizing through page scan that it has been paged, the paged device immediately starts a process of setting connection. In a normal state, connection is set.”

As described above, when wireless communication apparatuses are to communicate with each other, the first wireless communication apparatus which wants to perform wireless communication sends an inquiry signal to peripheral wireless communication apparatuses. The second wireless communication apparatus which has received the inquiry signal sends back a response to the first wireless communication apparatus. The first wireless communication apparatus receives the response to the inquiry, and discovers the wireless communication apparatus which exists near itself. To request connection, the first wireless communication apparatus sends a page signal to the second wireless communication which has sent back the response. Then, the second wireless communication apparatus receives the page signal, and sends back a page response to the first wireless communication apparatus. Connection between the wireless communication apparatuses is established through this process, and wireless communication is enabled.

2

Bluetooth assumes that a wireless communication apparatus establishes connections with a plurality of wireless communication apparatuses and communicates with them. Even if a wireless communication apparatus establishes connection with another wireless communication apparatus and does not want to be connected to still another wireless communication apparatus, the wireless communication apparatus performs response processing to an inquiry or page sent from still another wireless communication apparatus. This may interfere with communication with the currently connected wireless communication apparatus.

When authentication is set to be performed in connection, the wireless communication apparatus is prompted to input an authentication code every time it receives a page from another wireless communication apparatus. This forces the user to perform an unwanted operation.

BRIEF SUMMARY OF THE INVENTION

An object of the present invention is to provide a communication apparatus which, after establishing connection with a wireless communication apparatus, controls connection establishment with another wireless communication apparatus.

To achieve the above object, according to a first aspect of the invention, there is provided a communication apparatus comprising means for discovering completion of connection with another wireless communication apparatus, mode setup means for setting up a mode which defines processing for a signal for performing communication with the wireless communication apparatus from a wireless communication apparatus except for the another wireless communication apparatus, and means for shifting to the mode set up by the mode setup means when the discovery means discovers the completion of connection.

According to a second aspect of the invention, there is provided a communication method in a communication apparatus, comprising discovering completion of connection with another wireless communication apparatus and inhibiting connection with a wireless communication apparatus except for the another wireless communication apparatus.

According to the present invention, after a wireless communication apparatus establishes communication with another wireless communication apparatus, it can inhibit communication with still another wireless communication apparatus except for the currently connected wireless communication apparatus. This can prevent interference with communication with the connected wireless communication apparatus.

Additional objects and advantages of the invention will be set forth in the description which follows, and in part will be obvious from the description, or may be learned by practice of the invention. The objects and advantages of the invention may be realized and obtained by means of the instrumentalities and combinations particularly pointed out hereinafter.

BRIEF DESCRIPTION OF THE SEVERAL
VIEWS OF THE DRAWING

The accompanying drawings, which are incorporated in and constitute a part of the specification, illustrate embodiments of the invention, and together with the general description given above and the detailed description of the embodiments given below, serve to explain the principles of the invention.

US 7,127,210 B2

3

FIG. 1 is a view showing an example of the use environment of a wireless communication apparatus according to an embodiment of the present invention;

FIG. 2 is a functional block diagram showing a notebook type personal computer 1 as a wireless communication apparatus;

FIG. 3 is a table showing a mode setup table representing the relationship between a unique address and a mode selected upon connection establishment;

FIG. 4 is a flow chart for explaining the operation of the notebook type personal computer according to the first embodiment of the present invention;

FIG. 5 is a flow chart for explaining the operation of a wireless communication apparatus according to the second embodiment of the present invention; and

FIG. 6 is a flow chart for explaining the operation of a wireless communication apparatus according to the third embodiment of the present invention.

DETAILED DESCRIPTION OF THE INVENTION

First Embodiment

A wireless communication apparatus according to an embodiment of the present invention will be described below with reference to the several views of the accompanying drawing.

FIG. 1 is a view showing an example of the use environment of the wireless communication apparatus according to the embodiment of the present invention. In FIG. 1, a notebook type personal computer 1, PDA (Personal Digital Assistant) 2, and VTR camera 3 have Bluetooth modules, and are in a wireless communicable environment.

FIG. 2 is a functional block diagram showing the notebook type personal computer 1 as a wireless communication apparatus. Although FIG. 2 shows the notebook type personal computer 1, the PDA 2 and VTR camera 3 as other wireless communication apparatuses also have the same functions.

As shown in FIG. 2, the notebook type personal computer 1 comprises a user interface 11, control unit 12, mode setup unit 13, data processing unit 14, wireless data processing unit 15, wireless unit 16, and antenna 17.

The user interface 11 receives an inquiry or paging from the user, and sends the command to the control unit 12.

The control unit 12 sends the command from the user interface 11 as control data to the wireless data processing unit 15. The control unit 12 checks whether the received data which is demodulated and output from the wireless data processing unit 15 is control data or general data, and executes processing corresponding to the received data. If the received data is general data, the control unit 12 sends it to the data processing unit 14 which performs data processing.

If the received data is control data, the control unit 12 sends back corresponding control data to the wireless data processing unit 15, and sends the control information to the user interface 11 and mode setup unit 13.

The wireless data processing unit 15 modulates the control data and sends it to the wireless unit 16. The control data is transmitted to another wireless communication apparatus by generating radio waves from the antenna 17. The wireless data processing unit 15 demodulates received data and sends it to the control unit 12.

4

The wireless unit 16 uses the antenna 17 to receive radio waves generated from another wireless communication apparatus, and sends them to the wireless data processing unit 15.

When the mode setup unit 13 receives control data representing the completion of connection with another wireless communication apparatus, the mode setup unit 13 automatically changes setups for an inquiry or paging from still another wireless communication apparatus.

The setups of the mode are done for a mode setup table 18 representing the relationship between a unique address and a mode selected upon connection establishment, as shown in FIG. 3.

In FIG. 3, when connection with a device corresponding to unique address A is established, this means that the mode changes to non-connectable mode 1. When connection with a device corresponding to unique address B is established, this means that the mode changes to a non-discoverable mode.

The non-connectable mode and non-discoverable mode are defined by the Bluetooth standard. The "non-connectable mode" in which the wireless communication apparatus does not respond to a page signal from another wireless communication apparatus means that the wireless communication apparatus does not change to a page scan state. The non-discoverable mode in which the wireless communication apparatus does not respond to an inquiry signal from another wireless communication apparatus means that the wireless communication apparatus does not change to an inquiry signal response state.

The Bluetooth standard defines two types of non-connectable modes because the wireless communication apparatus either does not respond to a page or sends back a page denial upon reception of a page signal (to be described later).

When received data demodulated by the wireless data processing unit 15 concerns an inquiry or paging from another wireless communication apparatus, the control unit 12 sends a response to the inquiry or paging from the wireless communication apparatus to the wireless data processing unit 14 on the basis of a mode set up by the mode setup unit 13.

The operation of the notebook type personal computer according to the first embodiment of the present invention will be explained with reference to the flow chart of FIG. 4. In FIG. 4, the notebook type personal computer 1 is described as a wireless communication apparatus A; the PDA 2, as a wireless communication apparatus B; and the VTR camera 3, as a wireless communication apparatus C.

The user of the wireless communication apparatus A which is to start wireless communication instructs the control unit 12 through the user interface 11 to check wireless communication apparatuses present around the wireless communication apparatus A. The control unit 12 generates inquiry data upon reception of the request through the user interface 11. The inquiry data is sent to the wireless data processing unit 15 where it is modulated. The modulated inquiry data is sent to the wireless unit 16 and transmitted from the antenna 17 (SA1).

The wireless communication apparatus B receives the inquiry transmitted from the wireless communication apparatus A, and outputs the received inquiry from the wireless unit 16 to the wireless data processing unit 15. The wireless data processing unit 15 demodulates the received inquiry and sends it to the control unit 12 (SB1).

The control unit 12 of the wireless communication apparatus B determines that the inquiry has been received. Then, the control unit 12 generates inquiry response data including

US 7,127,210 B2

5

the unique address of the wireless communication apparatus B and sends it to the wireless data processing unit 15. The wireless data processing unit 15 modulates the inquiry response data and sends the modulated inquiry response data to the wireless unit 16. The inquiry response data is transmitted from the antenna 17 (SB2).

The wireless communication apparatus A receives by the antenna 17 the inquiry response transmitted from the wireless communication apparatus B. The received inquiry response is sent from the wireless unit 16 to the wireless data processing unit 15. The wireless data processing unit 15 modulates the received inquiry response and sends it to the control unit 12. The control unit 12 determines that the inquiry response has been received (SA2), and sends unique address information of the wireless communication apparatus B included in the received inquiry response to the user interface 11. The user interface 11 displays the unique address information of the wireless communication apparatus B.

The user of the wireless communication apparatus A which wants connection with the wireless communication apparatus B designates the unique address of the wireless communication apparatus B as a destination through the user interface 11, and sends a paging signal to the control unit 12. The control unit 12 generates page data to the wireless communication apparatus B and sends it to the wireless data processing unit 15. The page data modulated by the wireless data processing unit 15 is sent to the wireless unit 16 and transmitted from the antenna 17 (SA3).

The wireless communication apparatus B receives by the antenna 17 the page transmitted from the wireless communication apparatus A. The received page is demodulated by the wireless data processing unit 15 and sent to the control unit 12. The control unit 12 determines that the page has been received (SB3). The control unit 12 generates page response data and sends it to the wireless data processing unit 15. The page response data modulated by the wireless data processing unit 15 is sent to the wireless unit 16 and transmitted from the antenna 17 (SB4).

The wireless communication apparatus A receives by the antenna 17 the page response transmitted from the wireless communication apparatus B. The received page response is demodulated by the wireless data processing unit 15 and sent to the control unit 12. The control unit 12 determines that the page response has been received (SA4). If authentication is necessary, the control unit 12 causes the user interface 11 to display an authentication code input request. The user of the wireless communication apparatus A inputs the authentication code (SA5). The wireless communication apparatus A exchanges the authentication data with the wireless communication apparatus B and performs authentication (SA6).

After the wireless communication apparatus B transmits the page response, it causes the user interface 11 to display an authentication code input request if authentication with the wireless communication apparatus A is necessary. The user of the wireless communication apparatus B inputs the authentication code (SB5). The wireless communication apparatus B exchanges the authentication data with the wireless communication apparatus A and performs authentication (SB6).

If authentication in steps SA6 and SB6 succeeds, the wireless communication apparatuses A and B determine that connection is established, and send connection establishment information to their user interfaces 11. The user interfaces 11 of the respective wireless communication

6

apparatuses notify the users of the wireless communication apparatuses of connection establishment (SA7 and SB7).

If the control unit 12 determines in step SA7 in the wireless communication apparatus A or in step SB7 in the wireless communication apparatus B that connection has been established, the control unit 12 notifies the mode setup unit 13 of connection establishment. In the wireless communication apparatus A, the mode setup unit 13 sends to the control unit 12 an instruction for shifting to the non-discoverable mode, in accordance with a mode setup set in the mode setup table 18 in advance. Similarly in the wireless communication apparatus B, the mode setup unit 13 sends to the control unit 12 an instruction for shifting to the non-discoverable mode. Note that the mode setup tables 18 of the wireless communication apparatuses A and B are so set as to shift the mode to the non-discoverable mode when connection is established between the wireless communication apparatuses A and B. After connection is established between the wireless communication apparatuses A and B, the mode automatically shifts to the non-discoverable mode (SA8 and SB8). After connection establishment, data is exchanged between the wireless communication apparatuses A and B (SA9 and SB9).

If the third wireless communication apparatus C wants connection with the wireless communication apparatus B, the wireless communication apparatus C transmits an inquiry in step SC1 similarly to step SA1 of the wireless communication apparatus A.

In step SB10, the wireless communication apparatus B receives the inquiry from the wireless communication apparatus C by the same procedure as that in step SB1. The wireless communication apparatus B has received the inquiry from the wireless communication apparatus C, but the control unit 12 does not generate any response data to the inquiry because the wireless communication apparatus B has shifted to the non-discoverable mode. In step SB11, the wireless communication apparatus B does not transmit any inquiry response.

Since the wireless communication apparatus C cannot receive any inquiry response from the wireless communication apparatus B, it cannot discover the wireless communication apparatus B. In step SC2, an inquiry time-out occurs. The wireless communication apparatus C cannot acquire the unique address of the wireless communication apparatus B, and cannot request connection. The wireless communication apparatus C does not interfere with data transmission/reception between the wireless communication apparatuses A and B in steps SA9 and SB9.

After data transmission/reception between the wireless communication apparatuses A and B in steps SA9 and SB9 ends, the mode setup, i.e., non-discoverable mode is cleared in the wireless communication apparatus B (SB12). The wireless communication apparatus B shifts to a normal mode.

The wireless communication apparatus according to the first embodiment shifts to the non-discoverable mode after connection establishment. This can prevent interference with communication with a connected wireless communication apparatus.

Second Embodiment

The operation of a wireless communication apparatus according to the second embodiment of the present invention will be described with reference to the flow chart of FIG. 5.

US 7,127,210 B2

7

The process up to establishing connection between wireless communication apparatuses A and B, i.e., the process from step SA1 to step SA7 and from step SB1 to step SB7 is the same as that shown in FIG. 4.

If a control unit 12 determines in step SA7 in the wireless communication apparatus A or in step SB7 in the wireless communication apparatus B that connection has been established, the control unit 12 notifies a mode setup unit 13 of connection establishment. In the wireless communication apparatus A, the mode setup unit 13 sends, to the control unit 12 in accordance with a preset mode setup, an instruction for shifting to the non-connectable mode in which the wireless communication apparatus A sends a denial response to the received page. Also in the wireless communication apparatus B, the mode setup unit 13 sends to the control unit 12 an instruction for shifting to the non-connectable mode in which the wireless communication apparatus B sends a denial response to the received page. Note that mode setup tables 18 of the wireless communication apparatuses A and B are so set as to shift the mode to the non-connectable mode when connection is established between the wireless communication apparatuses A and B. After connection is established between the wireless communication apparatuses A and B, the mode automatically shifts to the non-connectable mode in which the wireless communication apparatus sends a denial response to a received page (SA8-1 and SB8-1).

Assume that a third wireless communication apparatus C wants connection with the wireless communication apparatus B. Further, assume that the wireless communication apparatus C acquires the unique address of the wireless communication apparatus B in advance by sending an inquiry and receiving an inquiry response before the wireless communication apparatus B shifts to the non-discoverable mode.

In step SC1-1, the wireless communication apparatus C designates the unique address of the wireless communication apparatus B and transmits a page. In step SB10-1, the wireless communication apparatus B receives the page from the wireless communication apparatus C. However, the wireless communication apparatus B has already shifted to the non-connectable mode. Thus, the control unit 12 generates a page denial response data (SB10-1) and transmits the page denial response (SB11-1).

The wireless communication apparatus C receives the page denial response from the wireless communication apparatus B (SC2-1). Since connection establishment fails, the control unit 12 notifies a user interface 11 of the connection establishment failure, and causes the user interface 11 to display the connection establishment failure (SC3-1). The wireless communication apparatus C cannot establish connection with the wireless communication apparatus B. The wireless communication apparatus C does not interfere with data transmission/reception between the wireless communication apparatuses A and B in steps SA9 and SB9.

After data transmission/reception between the wireless communication apparatuses A and B in steps SA9 and SB9 ends, the mode setup, i.e., non-discoverable mode is cleared in the wireless communication apparatus B (SB12). The wireless communication apparatus B shifts to a normal mode.

The wireless communication apparatus according to the second embodiment shifts to the non-connectable mode after connection establishment, and transmits a page denial signal in response to a page signal from another wireless commu-

8

nication apparatus. This can prevent interference with communication with a connected wireless communication apparatus.

Third Embodiment

The operation of a wireless communication apparatus according to the third embodiment of the present invention will be described with reference to the flow chart of FIG. 6.

The process up to establishing connection between wireless communication apparatuses A and B, i.e., the process from step SA1 to step SA7 and from step SB1 to step SB8 is the same as that shown in FIG. 4.

If a control unit 12 determines in step SA7 in the wireless communication apparatus A or in step SB7 in the wireless communication apparatus B that connection has been established, the control unit 12 notifies a mode setup unit 13 of connection establishment.

In the wireless communication apparatus A, the mode setup unit 13 sends, to the control unit 12 in accordance with a preset mode setup, an instruction for shifting to the non-connectable mode in which the wireless communication apparatus A does not respond to a received page. Also in the wireless communication apparatus B, the mode setup unit 13 sends to the control unit 12 an instruction for shifting to the non-connectable mode in which the wireless communication apparatus B does not respond to a received page. Note that mode setup tables 18 of the wireless communication apparatuses A and B are so set as to shift the mode to the non-connectable mode when connection is established between the wireless communication apparatuses A and B. After connection is established between the wireless communication apparatuses A and B, the mode automatically shifts to the non-connectable mode in which the wireless communication apparatus does not respond to a received page (SA8-2 and SB8-2).

Assume that a third wireless communication apparatus C wants connection with the wireless communication apparatus B. Further, assume that the wireless communication apparatus C acquires the unique address of the wireless communication apparatus B in advance by sending an inquiry and receiving an inquiry response before the wireless communication apparatus B shifts to the non-discoverable mode.

In step SC1-2, the wireless communication apparatus C designates the unique address of the wireless communication apparatus B and transmits a page. In step SB10-2, the wireless communication apparatus B receives the page from the wireless communication apparatus C. However, the wireless communication apparatus B has already shifted to the non-connectable mode. Thus, the control unit 12 does not generate any response data to the page, and does not transmit any response to the page (SB11-1).

The wireless communication apparatus C does not receive any page response from the wireless communication apparatus B. A time-out occurs (SC2-2), and the wireless communication apparatus C fails to establish connection. Since the wireless communication apparatus C fails to establish connection with the wireless communication apparatus B, the control unit 12 notifies a user interface 11 of the connection establishment failure, and causes the user interface 11 to display the connection establishment failure (SC3-2). The wireless communication apparatus C cannot establish connection with the wireless communication apparatus B. The wireless communication apparatus C does not

US 7,127,210 B2

9

interfere with data transmission/reception between the wireless communication apparatuses A and B in steps SA9 and SB9.

The wireless communication apparatus according to the third embodiment shifts to the non-connectable mode after connection establishment, and does not respond to a page signal from another wireless communication apparatus. This can prevent interference with communication with a connected wireless communication apparatus.

The above embodiments have separately described shift to the non-connectable mode and shift to the non-discoverable mode. However, the wireless communication apparatus may simultaneously shift to the non-connectable mode and non-discoverable mode after connection is established.

In the above embodiments, the third wireless communication apparatus C sends a paging signal to the wireless communication apparatus B which receives a page from the wireless communication apparatus A and responds to the page to establish the first connection with the wireless communication apparatus A. The present invention is also effective when the wireless communication apparatus C sends a paging signal to the wireless communication apparatus A because the wireless communication apparatus A also automatically shifts to the non-discoverable mode or non-connectable mode after the first connection is established.

As described above, the wireless communication apparatus of the embodiments establishes connection with another wireless communication apparatus, and then automatically changes setups for an inquiry or paging with respect to still another wireless communication apparatus. The wireless communication apparatus does not send back any response or sends back an inquiry denial response, thereby denying connection establishment with still another wireless communication apparatus except for the currently connected wireless communication apparatus. This can prevent interference with communication between currently connected wireless communication apparatuses.

The present invention is not limited to the above-described embodiments, and can be variously modified without departing from the spirit and scope of the invention in practical use. The respective embodiments can be combined as properly as possible. In this case, the effects of the combination can be obtained. The embodiments include inventions on various stages, and various inventions can be extracted by an appropriate combination of building components disclosed. For example, when an invention is extracted by omitting several building components from all the building components described in the embodiments, the omission is properly compensated for by a well-known technique in practicing the extracted invention.

As has been described in detail, the present invention can provide a wireless communication apparatus which, after establishing connection with another wireless communication apparatus, denies connection establishment with still another wireless communication apparatus except for the currently connected wireless communication apparatus, and does not interfere with communication between the currently connected wireless communication apparatuses.

Additional advantages and modifications will readily occur to those skilled in the art. Therefore, the invention in its broader aspects is not limited to the specific details and representative embodiments shown and described herein. Accordingly, various modifications may be made without departing from the spirit or scope of the general inventive concept as defined by the appended claims and their equivalents.

10

What is claimed is:

1. A wireless communication apparatus comprising:
 - a unit configured to set up a first mode where the wireless communication apparatus is connectable with at least a first wireless communication device and a second wireless communication device and accepts a connection request from the first wireless communication device;
 - a unit configured to establish a connection with the first wireless communication device;
 - a unit configured to discover a completion of the connection with the first wireless communication device;
 - a unit configured to set up a second mode where, in a state where the connection with the first wireless communication device is established, the wireless communication apparatus is inhibited from establishing a connection with the second wireless communication device with respect to a connection request from the second wireless communication device; and
 - a unit configured to shift from the first mode to the second mode when said discovering unit discovers the completion of the connection.
2. An apparatus according to claim 1, wherein the second mode includes a non-discoverable mode in which the wireless communication apparatus does not respond to an inquiry signal.
3. An apparatus according to claim 1, wherein the second mode includes a non-connectable mode in which no connection is performed for paging.
4. An apparatus according to claim 2, wherein the second mode includes a non-discoverable mode based on a Bluetooth standard.
5. An apparatus according to claim 3, wherein the second mode includes a non-connectable mode based on a Bluetooth standard.
6. An apparatus according to claim 4, wherein the non-discoverable mode does not respond to an inquiry.
7. An apparatus according to claim 5, wherein the non-connectable mode sends a connection denial response to a paging signal.
8. An apparatus according to claim 5, wherein the non-connectable mode does not respond to a paging signal.
9. An apparatus according to claim 1, wherein the second mode includes a non-discoverable mode and non-connectable mode based on a Bluetooth standard.
10. An apparatus according to claim 1, wherein the second mode inhibits connection with another wireless communication apparatus.
11. An apparatus according to claim 1, wherein the second mode is canceled after end of communication with the first wireless communication device.
12. A communication method in a wireless communication apparatus, comprising:
 - setting up a first mode where the wireless communication apparatus is connectable with at least a first wireless communication device and a second wireless communication device and accepts a connection request from the first wireless communication device;
 - establishing a connection with the first wireless communication device;
 - discovering a completion of the connection with the wireless communication apparatus;
 - setting up a second mode where, in a state where the connection with the first wireless communication device is established, the wireless communication

US 7,127,210 B2

11

apparatus is inhibited from establishing a connection with the second wireless communication device with respect to a connection request from the second wireless communication device; and shifting from the first mode to the second mode after the completion of the connection. 5

13. A method according to claim 12, wherein the second mode includes a non-discoverable mode in which the wireless communication apparatus does not respond to an inquiry signal. 10

14. A method according to claim 12, wherein the second mode includes a non-connectable mode in which no connection is performed for paging.

15. A method according to claim 13, wherein the second mode includes a non-discoverable mode based on a Bluetooth standard. 15

16. A method according to claim 14, wherein the second mode includes a non-connectable mode based on a Bluetooth standard.

17. A method according to claim 15, wherein the wireless communication apparatus does not respond to an inquiry signal from another wireless communication apparatus after shifting to the second mode. 20

18. A method according to claim 16, wherein the wireless communication apparatus sends a connection denial response to a paging signal after shifting to the second mode. 25

19. A method according to claim 16, wherein the wireless communication apparatus does not respond to a paging signal after shifting to the second mode.

12

20. A communication apparatus comprising: a unit configured to establish a connection with a first wireless communication apparatus in a first mode; and a unit configured to control a connection from a second wireless communication apparatus when the connection with the first wireless communication apparatus is established, wherein the control unit sets up a second mode in which, in a state where the connection with the first wireless communication device is established, the communication apparatus is inhibited from establishing a connection with the second wireless communication apparatus with respect to a connection request from the second wireless communication device.

21. A communication method in a communication apparatus, comprising: establishing a connection with a first wireless communication apparatus in a first mode; and controlling a connection from a second wireless communication apparatus when the connection with the first wireless communication apparatus is established, wherein controlling includes setting up a second mode in which, in a state where the connection with the first wireless communication device is established, the communication apparatus is inhibited from establishing a connection with the second wireless communication apparatus with respect to a connection request from the second wireless communication device.

* * * * *

EXHIBIT 8

TP-Link Bluetooth Music Receiver



20. A communication apparatus comprising:

a unit configured to establish a connection with a first wireless communication apparatus in a first mode;

and

a unit configured to control a connection from a second wireless communication apparatus when the connection with the first wireless communication apparatus is established, wherein the control unit sets up a second mode in which, in a state where the connection with the first wireless communication device is established, the communication apparatus is inhibited from establishing a connection with the second wireless communication apparatus with respect to a connection request from the second wireless communication device.

Claim 20

Source: https://static.tp-link.com/res/down/doc/HA100_V1_UG.pdf "HA100 User Guide Bluetooth Music Receiver"

20. A communication device, comprising:



Claim 20

<https://fccid.io/TE7HA100/Internal-Photos/Internal-Photos-rev-2-2639363>

a unit configured to establish a connection with a first wireless communication apparatus in a first mode; and

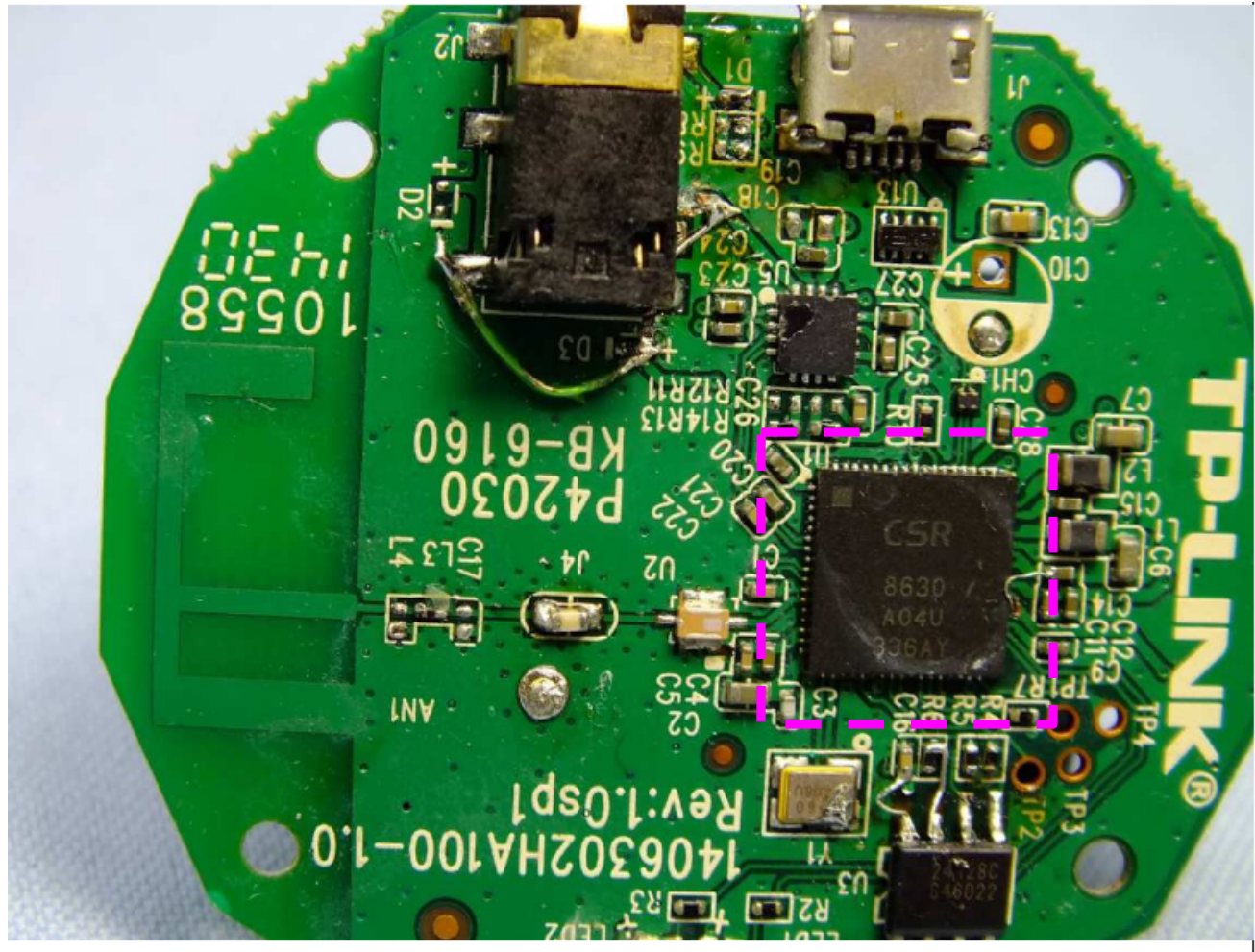

Claim 20

Source: https://www.youtube.com/watch?v=ovHoseuc_gs "TP-Link HA100 Bluetooth Music Receiver"

a unit configured to establish a connection with a first wireless communication apparatus in a first mode; and

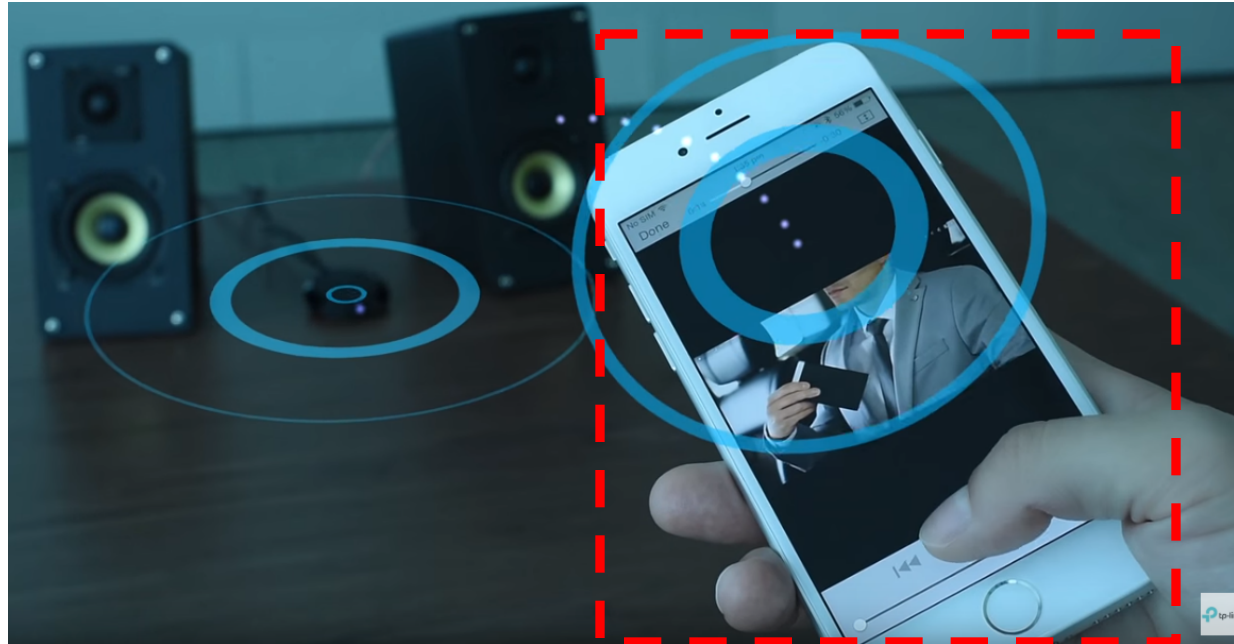

Claim 20										
<p>a unit configured to establish a connection with a first wireless communication apparatus in a first mode; and</p>	<p>Source: https://static.tp-link.com/res/down/doc/HA100_V1_UG.pdf "HA100 User Guide Bluetooth Music Receiver" Page 2</p> <p>The music receiver's LED is located on the top panel.</p> <table border="1"> <thead> <tr> <th data-bbox="428 654 763 718">Name</th> <th data-bbox="763 654 898 718">Status</th> <th data-bbox="898 654 1806 718">Indication</th> </tr> </thead> <tbody> <tr> <td data-bbox="428 718 763 835">Status LED</td> <td data-bbox="763 718 898 835">On</td> <td data-bbox="898 718 1806 835">White: The music receiver is powered on and ready to be paired. Blue: A smart device is connected.</td> </tr> <tr> <td data-bbox="428 835 763 882"></td> <td data-bbox="763 835 898 882">Off</td> <td data-bbox="898 835 1806 882">The music receiver is powered off.</td> </tr> </tbody> </table>	Name	Status	Indication	Status LED	On	White: The music receiver is powered on and ready to be paired. Blue: A smart device is connected.		Off	The music receiver is powered off.
Name	Status	Indication								
Status LED	On	White: The music receiver is powered on and ready to be paired. Blue: A smart device is connected.								
	Off	The music receiver is powered off.								

Claim 20

a unit configured to control a connection from a second wireless communication apparatus when the connection with the first wireless communication apparatus is established

<https://fccid.io/TE7HA100/Internal-Photos/Internal-Photos-rev-2-2639363/>

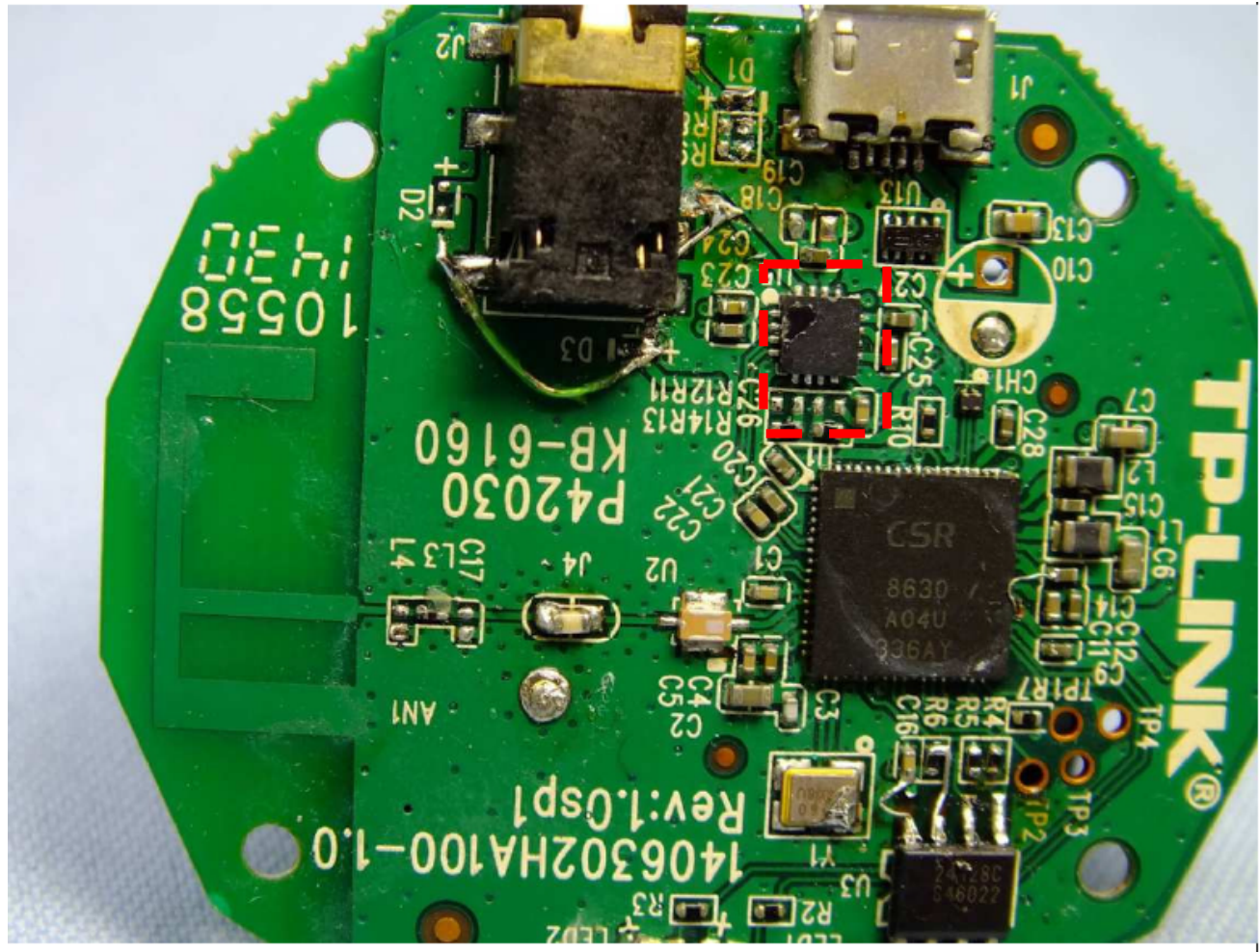

Claim 20	
<p>wherein the control unit sets up a second mode in which, in a state where the connection with the first wireless communication device is established</p>	<p>https://stackoverflow.com/questions/27360338/how-does-bluetooth-pairing-work</p> <p>The diagram shows the following steps:</p> <ol style="list-style-type: none"> 1) User wishes to complete an action "Add Device" -> Searching... (A box labeled "Searching / Discoverable" is shown) 2) Device List <ol style="list-style-type: none"> If device(s) in the Device List -> User may select device from list If no device in the Device List -> "No Devices Found" -> "Add Device" (A vertical line separates the Initiator's actions from the Responder's actions.) 3) Select Device (may be implicit) -> Select device from the Device List 4) Accept Connection from <Initiator Name>? (may be implicit) <ul style="list-style-type: none"> -> "YES" Device accepts connection -> "NO" Device denies connection <p>Annotations:</p> <ul style="list-style-type: none"> The arrow "->" shows that there is some UI impact (pointing to the arrow between step 1 and 2) If in the middle, interaction may occur on one or both sides (pointing to the Device List step) If a line divides the roles, there are separate interactions happening (pointing to the vertical line between steps 2 and 3)

Claim 20	
<p>the communication apparatus is inhibited from establishing a connection with the second wireless communication apparatus with respect to a connection request from the second wireless communication device.</p>	<p>Source: https://static.tp-link.com/res/down/doc/HA100_V1_UG.pdf "HA100 User Guide Bluetooth Music Receiver" Page 3</p> <div data-bbox="502 392 1864 621"><p>Usage Tips:</p><ol style="list-style-type: none">1. Tapping the paired music receiver will disconnect or reconnect it.2. To pair a new smart device, disconnect the current one first.3. You can connect the music receiver to two previously paired devices, but it can only play music from one device at a time.4. The music receiver will be disconnected if your device's Bluetooth signal has been blocked or out of range (66 feet/20 meters) for more than 5 minutes.</div> <p>https://stackoverflow.com/questions/27360338/how-does-bluetooth-pairing-work</p> <p>NOTE: Devices in Device List may be filtered</p> <div data-bbox="531 1135 956 1192"><p>3) Select Device (may be implicit) -> Select device from the Device List</p></div> <div data-bbox="1207 1206 1719 1320"><p>4) Accept Connection from <Initiator Name>? (may be implicit) -> "YES" Device accepts connection > "NO" Device denies connection</p></div> <p>If a line divides the roles, there are separate interactions happening</p>

EXHIBIT 9



US007460477B2

(12) **United States Patent**
Yata et al.

(10) **Patent No.:** **US 7,460,477 B2**
 (45) **Date of Patent:** **Dec. 2, 2008**

- (54) **ELECTRONIC APPARATUS WITH COMMUNICATION DEVICE**
- (75) Inventors: **Koichi Yata**, Hanno (JP); **Tooru Homma**, Kawaguchi (JP)
- (73) Assignee: **Kabushiki Kaisha Toshiba**, Tokyo (JP)
- (*) Notice: Subject to any disclaimer, the term of this patent is extended or adjusted under 35 U.S.C. 154(b) by 834 days.

2002/0081977	A1*	6/2002	McCune, Jr.	455/67.1
2002/0131388	A1	9/2002	Ami et al.	
2002/0191722	A1	12/2002	Naruse	
2003/0112784	A1*	6/2003	Lohtia et al.	370/342
2003/0165148	A1*	9/2003	Bishard	370/412
2004/0004973	A1*	1/2004	Lee	370/445
2004/0023660	A1*	2/2004	Ben-Eli	455/450
2004/0125797	A1*	7/2004	Raisanen	370/389
2004/0233903	A1*	11/2004	Samaras et al.	370/389

FOREIGN PATENT DOCUMENTS

EP 1 133 095 A1 9/2001

(Continued)

OTHER PUBLICATIONS

English-language translation of Notification of Reasons for Rejection, issued by the Japanese Patent Office, mailed Feb. 8, 2005, for Japanese Patent Application No. 2003-065410.
 Notification of Reasons for Rejection mailed May 31, 2005, by the Japanese Patent Office, in Japanese Patent Application No. 2003-065410.

(Continued)

Primary Examiner—Ricky Ngo
Assistant Examiner—Wei-Po Kao
 (74) *Attorney, Agent, or Firm*—Finnegan, Henderson, Farabow, Garrett & Dunner, L.L.P.

(57) **ABSTRACT**

An electronic apparatus executes communication with an external device. The electronic apparatus includes an encoder that encodes source data to generate transmission data, a communication device that transmits the transmission data generated by the encoder to the external device, a unit that determines the quality with which the source data is to be transmitted, in accordance with the type of the source data, and a unit that controls the encoder to vary an amount of the generated transmission data on the basis of the determined quality.

12 Claims, 6 Drawing Sheets

- (21) Appl. No.: **10/795,974**
- (22) Filed: **Mar. 10, 2004**
- (65) **Prior Publication Data**
 US 2004/0240418 A1 Dec. 2, 2004
- (30) **Foreign Application Priority Data**
 Mar. 11, 2003 (JP) 2003-065410
- (51) **Int. Cl.**
H04L 12/26 (2006.01)
- (52) **U.S. Cl.** **370/232**
- (58) **Field of Classification Search** 370/389,
 370/252, 347, 280, 336, 223, 431, 412, 329,
 370/335, 229, 230, 232, 310; 375/242, 262,
 375/295; 709/241, 238, 239
 See application file for complete search history.

- (56) **References Cited**
 U.S. PATENT DOCUMENTS
 6,163,577 A * 12/2000 Ekudden et al. 375/242
 6,385,183 B1 * 5/2002 Takeo 370/335
 6,782,429 B1 * 8/2004 Kisor 709/241
 6,879,572 B1 * 4/2005 Ayyagari et al. 370/335
 6,920,118 B2 * 7/2005 Lozano 370/329

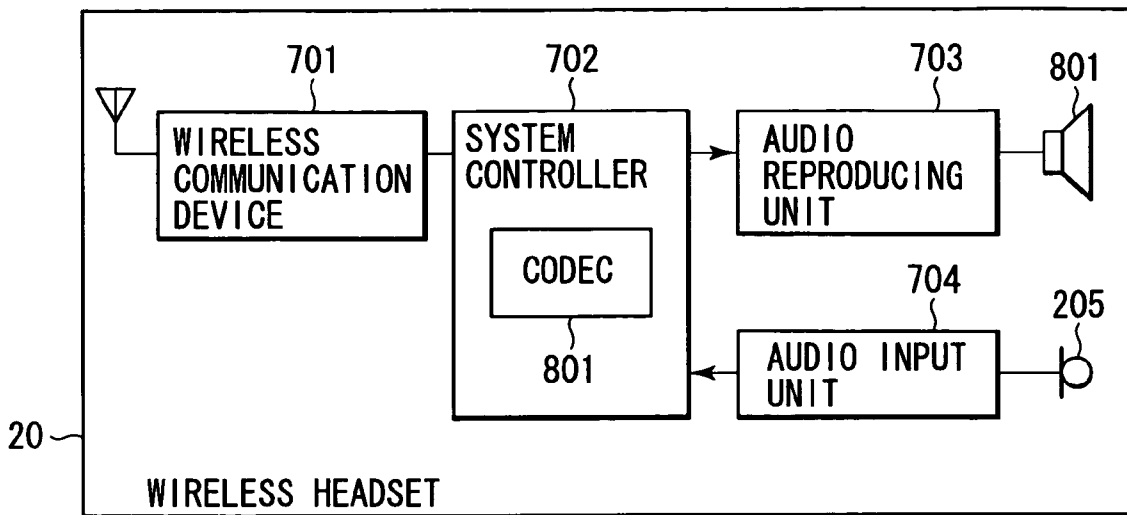

US 7,460,477 B2

Page 2

FOREIGN PATENT DOCUMENTS

JP	7-222245	8/1995
JP	2002-112383	4/2002
JP	2002-288073	10/2002
JP	2002-290974	10/2002
JP	2002-344941	11/2002

OTHER PUBLICATIONS

Communication dated Dec. 19, 2007 from the European Patent Office transmitting European Search Report for European Patent Application No. 04005002.3.

* cited by examiner

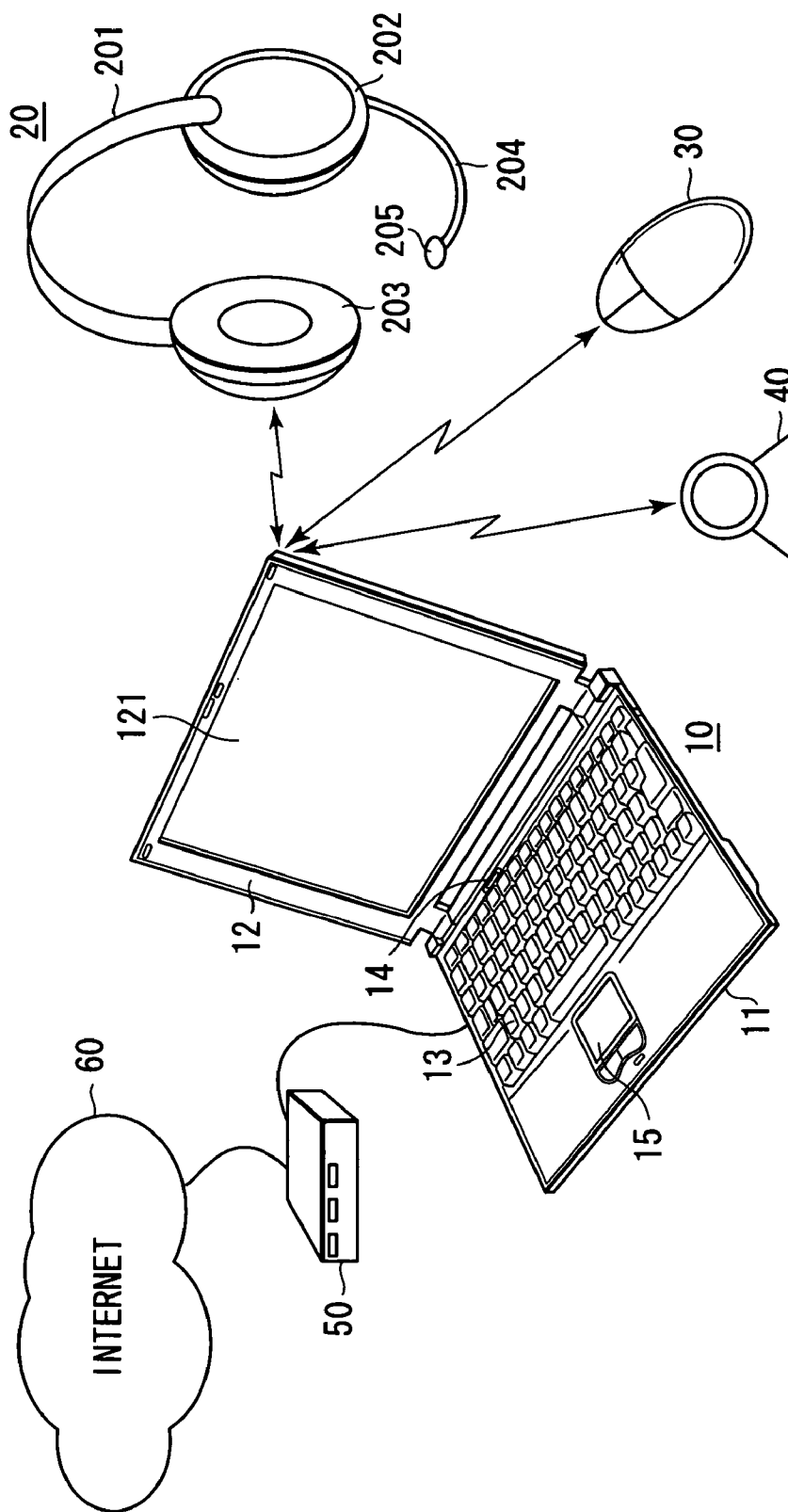

FIG. 1

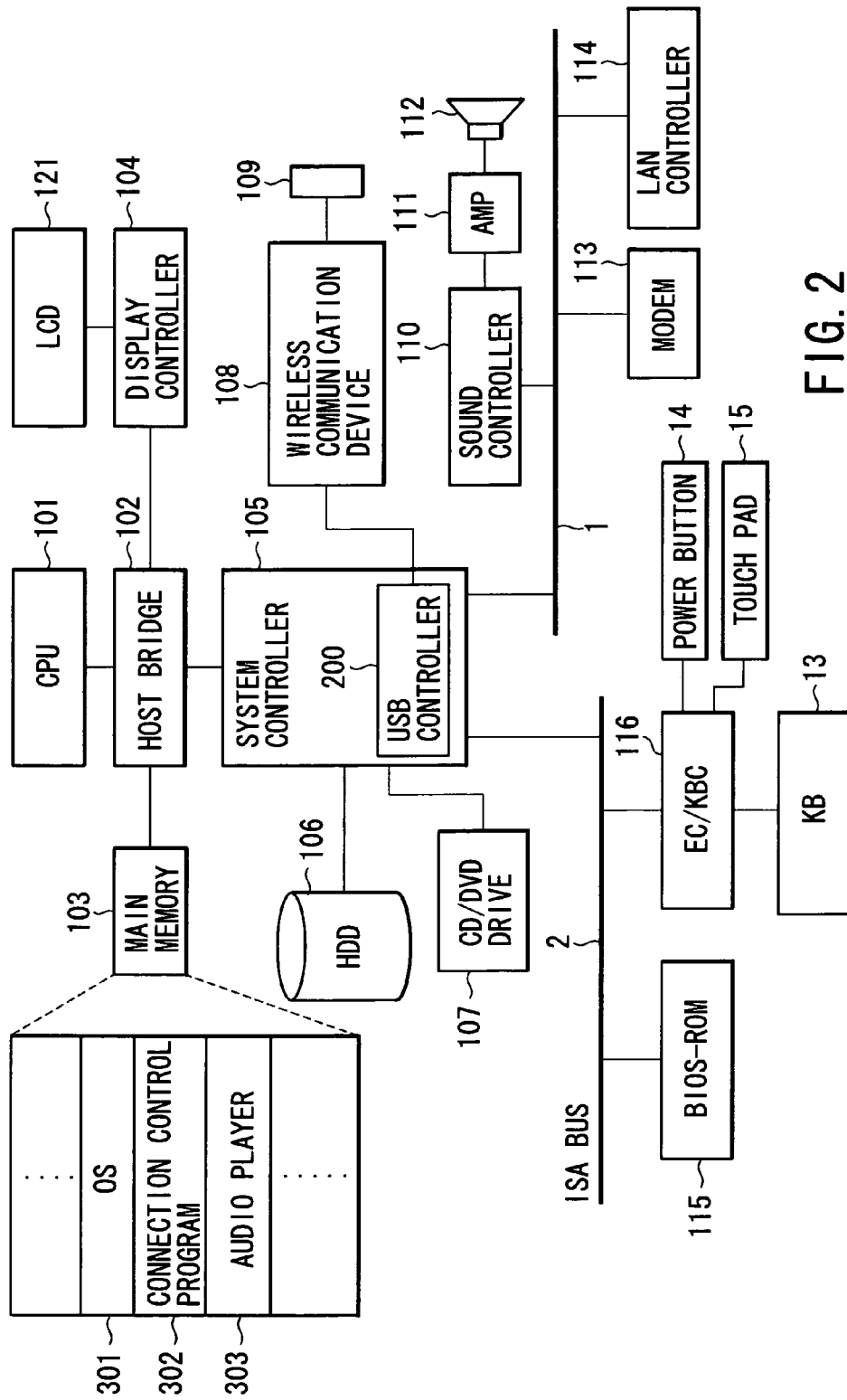

FIG. 2

300
{

TYPE OF AUDIO (S)	DRIVE/INTERNET	QUALITY
1	HDD	×
2	CD/DVD DRIVE	○
3	INTERNET (HIGH-SPEED)	○
4	INTERNET (LOW-SPEED)	×
5	NON-DEFINED	○

FIG. 3

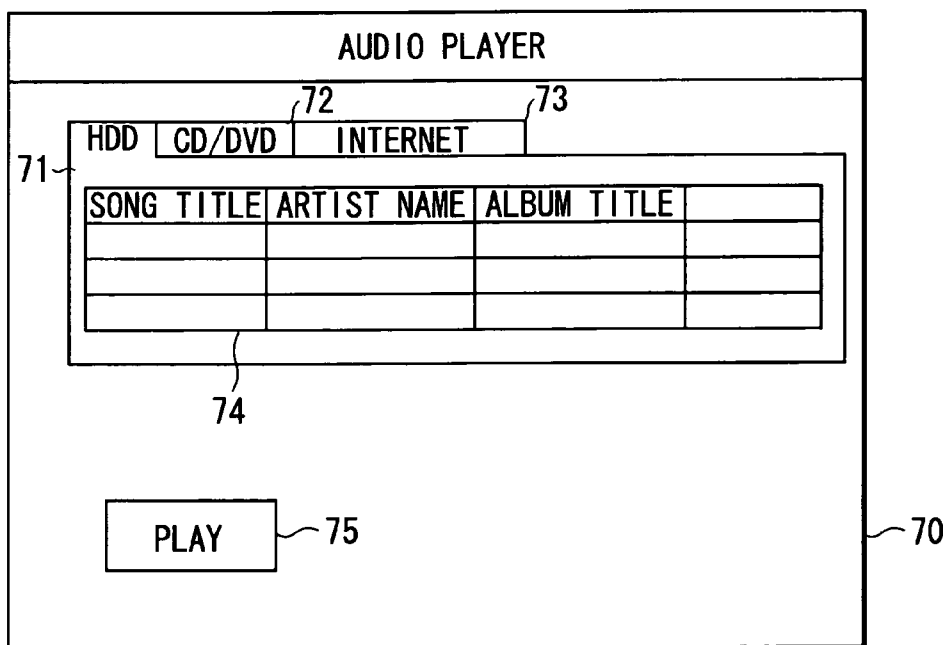

FIG. 4

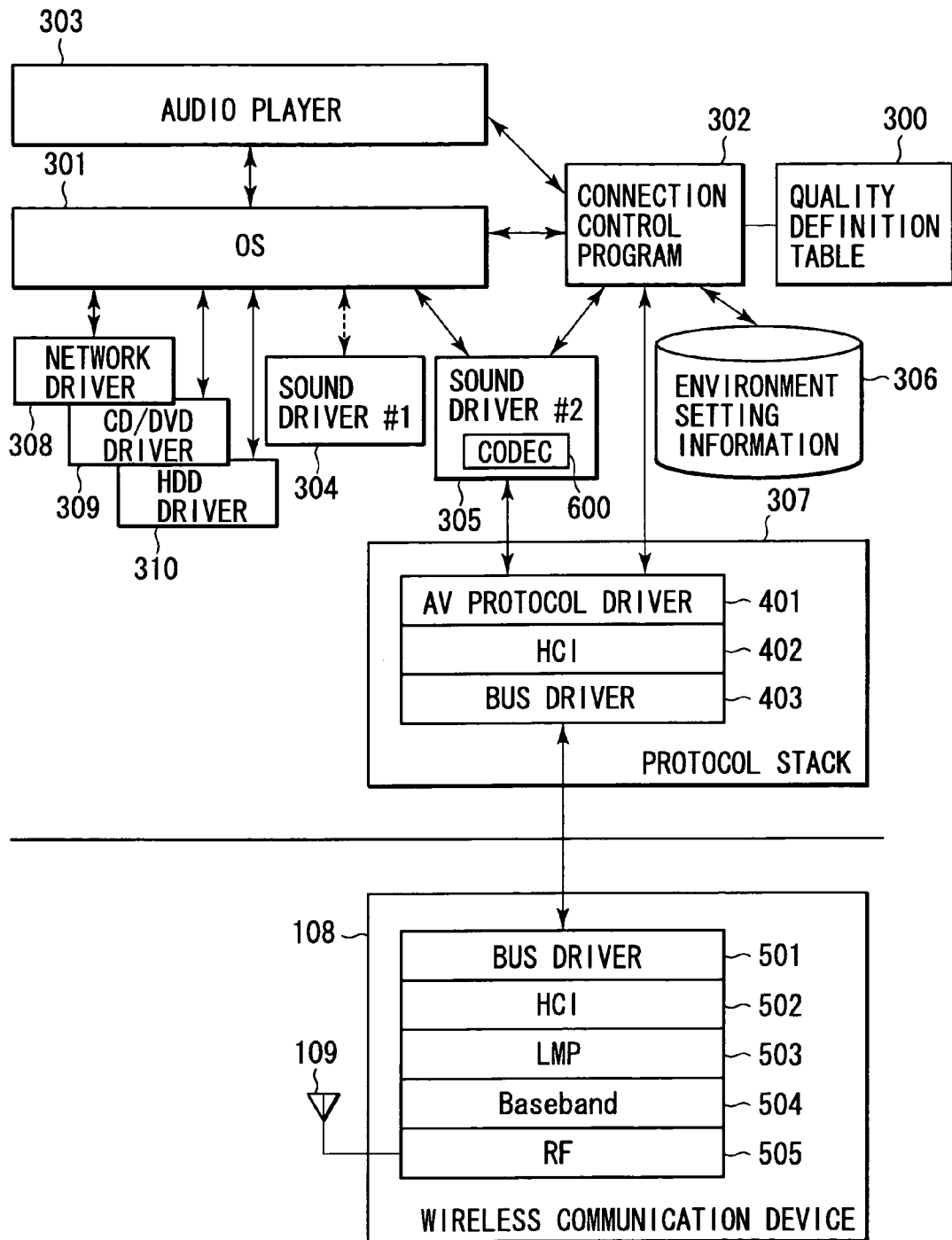

FIG. 5

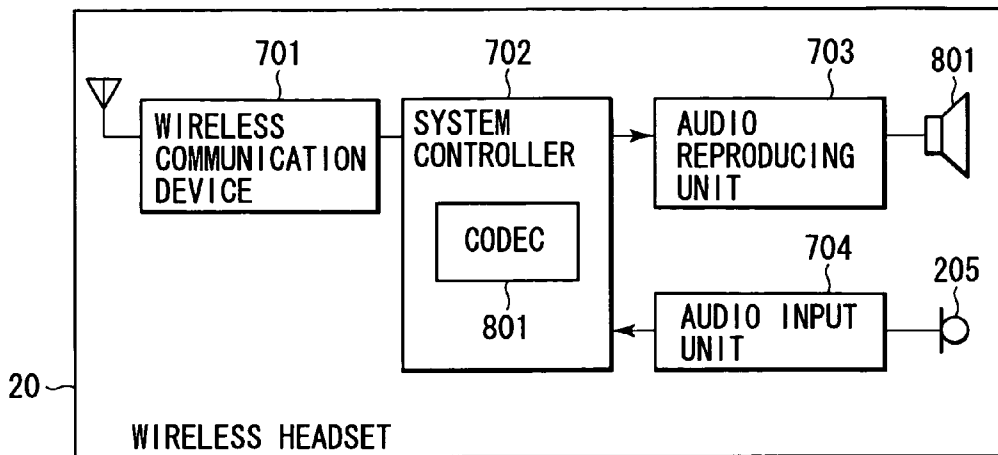

FIG. 6

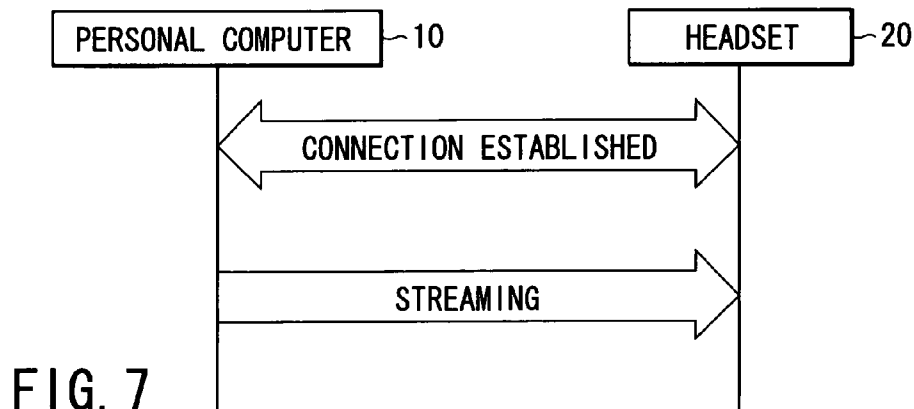

FIG. 7

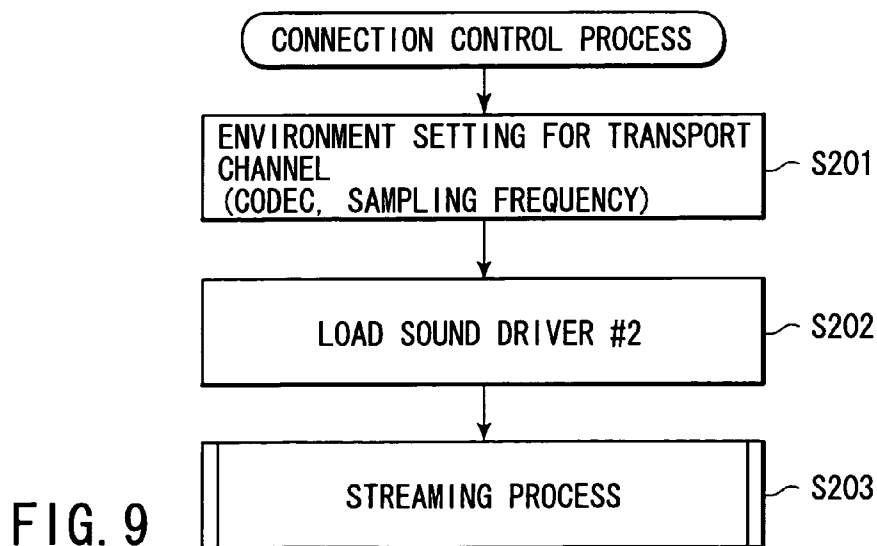

FIG. 9

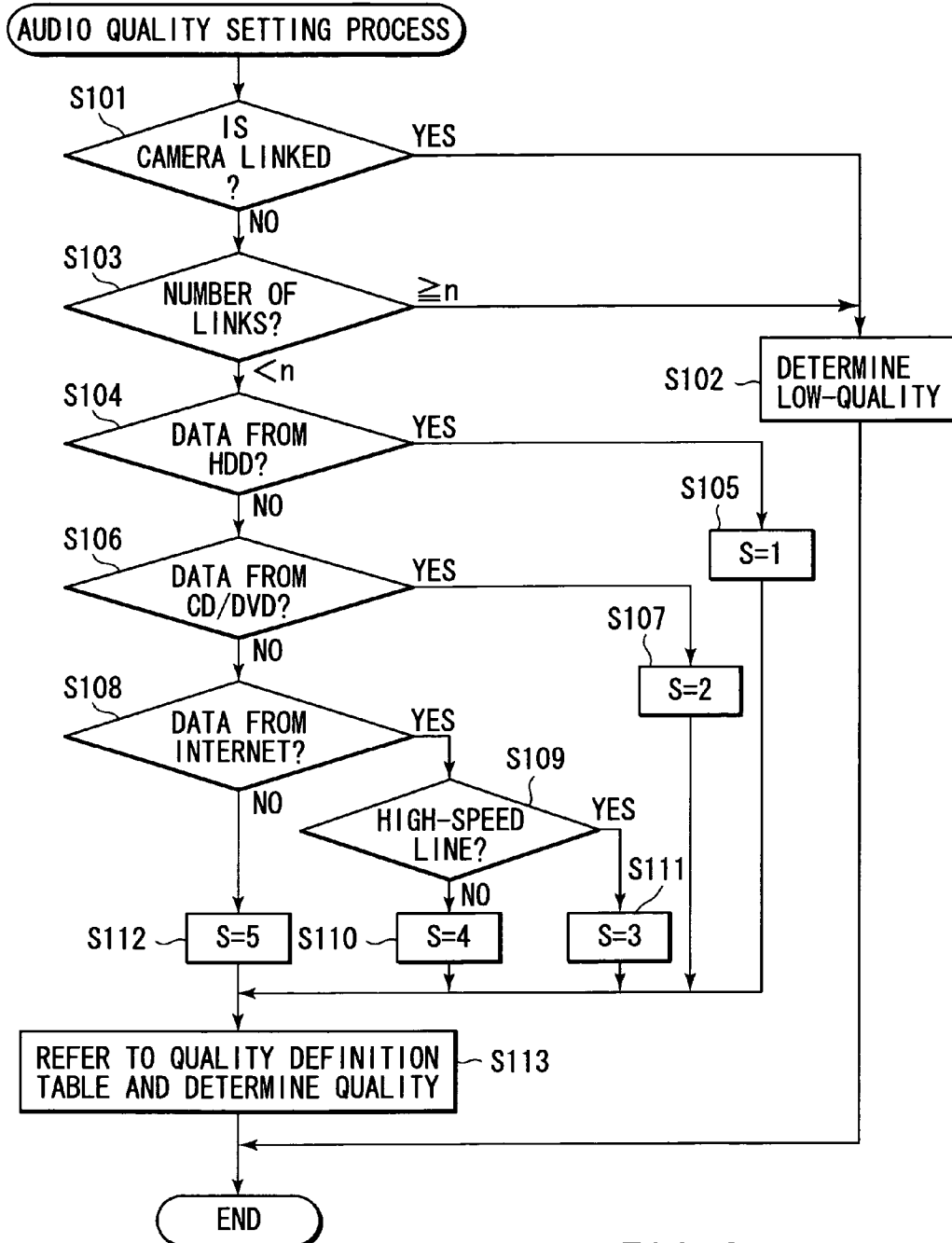

FIG. 8

US 7,460,477 B2

1

**ELECTRONIC APPARATUS WITH
COMMUNICATION DEVICE****CROSS-REFERENCE TO RELATED
APPLICATIONS**

This application is based upon and claims the benefit of priority from prior Japanese Patent Application No. 2003-65410, filed Mar. 11, 2003, the entire contents of which are incorporated herein by reference.

BACKGROUND OF THE INVENTION**1. Field of the Invention**

The present invention relates to an electronic apparatus capable of transmitting content such as music to an external device, and also relates to a program for controlling communication of the electronic apparatus.

2. Description of the Related Art

In recent years, attention has been paid to Bluetooth™ as a wireless communication technology. Bluetooth™ is a low-cost, low-power-consumption, short-range wireless communication technology suitable for mobile devices. Bluetooth™ is used for mutual connection of various mobile information devices owned by individual users. The devices are wirelessly connected and, compared to conventional connection by wire, the devices can be connected more freely, simply and easily.

Jpn. Pat. Appln. KOKAI Publication No. 2002-112383 discloses a system wherein music data is transmitted from an electronic device such as a music player to headphones by means of radio signals.

In order to reproduce music with high quality by headphones, it is necessary to enhance the quality relating to transmission of music data from the electronic apparatus to the headphones.

Bluetooth™ is capable of not only one-to-one communication, but also one-to-many communication. However, the wireless communication bandwidth of Bluetooth™ is narrow. If music data is always transmitted with high quality, almost all the available wireless communication bandwidth is occupied by the transmission of music data. In this case, such a problem arises that wireless communication between a device other than the headphones and the electronic apparatus is disrupted.

In addition, in a case where the quality of music source itself is low, even if the music source is transmitted with high quality using a wide communication bandwidth, an excess communication bandwidth is uselessly occupied without enhancing the quality of music reproduced from the headphones.

BRIEF SUMMARY OF THE INVENTION

According to an embodiment of the present invention, there is provided an electronic apparatus comprising: an encoder that encodes source data to generate transmission data; a communication device that transmits the transmission data generated by the encoder to an external device; means for determining a quality with which the source data is to be transmitted, in accordance with a type of the source data; and means for controlling the encoder to vary an amount of the generated transmission data on the basis of the determined quality.

2

**BRIEF DESCRIPTION OF THE SEVERAL
VIEWS OF THE DRAWING**

The accompanying drawings, which are incorporated in and constitute a part of the specification, illustrate embodiments of the invention, and together with the general description given above and the detailed description of the embodiments given below, serve to explain the principles of the invention.

FIG. 1 shows an external appearance of a computer according to an embodiment of the present invention;

FIG. 2 is a block diagram showing the system configuration of the computer of FIG. 1;

FIG. 3 shows an example of a quality definition table for use in the computer of FIG. 1;

FIG. 4 shows an example of an operation screen of an audio player that is used in the computer of FIG. 1;

FIG. 5 is a block diagram showing the software scheme of the computer of FIG. 1;

FIG. 6 is a block diagram showing a system configuration of a headset that is wirelessly connected to the computer of FIG. 1;

FIG. 7 illustrates a connection establishing process that is executed by the computer of FIG. 1;

FIG. 8 is a flow chart illustrating the procedure of a transmission quality determination process that is executed by the computer of FIG. 1; and

FIG. 9 is a flow chart illustrating the procedure of a connection control process that is executed by the computer of FIG. 1.

DETAILED DESCRIPTION OF THE INVENTION

An embodiment of the present invention will now be described with reference to the accompanying drawings.

FIG. 1 shows the external appearance of an electronic apparatus 10 according to an embodiment of the invention. The electronic apparatus 10 is configured to be able to transmit a stream of content data such as music or voice to an external device 20 by radio signals. The electronic apparatus 10 is realized by, e.g. a notebook personal computer, and the external device 20 is realized by, e.g. a wireless headset.

The personal computer 10 is a portable information processing apparatus that can be driven by a battery. The personal computer 10 comprises a computer main body 11 and a display unit 12. A display device composed of an LCD (Liquid Crystal Display) 121 is built in the display unit 12. The LCD 121 is positioned at a substantially central area of the display unit 12.

The display unit 12 is attached to be rotatable between an open position and a closed position relative to the computer main body 11. The computer main body 11 has a thin box-shaped casing. A keyboard 13, a power button 14 for powering on/off the computer 10, a touch pad (pointing device) 15, etc. are disposed on the upper surface of the computer main body 11.

A wireless communication device is built in the computer main body 11. The wireless communication device enables the computer 10 to perform communication with the headset 20. The wireless communication device is configured to execute wireless communication according to Bluetooth™ standards.

In Bluetooth™, SS-FH (spread spectrum-frequency hopping) is used. 79 frequency channels are assigned to a frequency band of 2.4 GHz at intervals of 1 MHz. Frequency channels that are used are switched in units of a packet according to a hopping sequence ("frequency hopping").

US 7,460,477 B2

3

Wireless communication by Bluetooth™ standards is realized by a master-slave configuration, and the master manages the hopping sequence. Using the same hopping pattern, a wireless network called “piconet” can be formed between one master and seven or less slaves.

The computer **10** can perform, using the wireless network, communication with a mouse **30** and a camera **40** as well as with the headset **20**.

A connection control program, which is a program for controlling wireless communication with the headset **20**, is installed in the computer **10**. The connection control program controls transmission of audio data such as music from the computer **10** to the headset **20**.

In Bluetooth™, Advanced Audio Distribution Profile (A2DP) is specified as a profile relating to transmission of audio data. A2DP is a function for transmitting audio data such as music with high quality. In A2DP, an asynchronous data channel called ACL (Asynchronous Connectionless) is utilized.

The connection control program controls the wireless communication device, thereby executing a procedure for transmitting audio data to the headset **20** using A2DP. Not only various audio data stored as music data files in the computer **10** but also various audio data received from the Internet **60** via a modem **50** can be used as source data of audio that is to be reproduced by the headset **20**.

The connection control program has a function of dynamically varying the quality, with which source data is to be transmitted, in accordance with the type of the source data that is to be reproduced by the headset **20**. The source data is converted to transmission data having a predetermined transmission data format, and the transmission data is transmitted as an audio stream from the computer **10** to the headset **20**. The transmission data is generated by encoding the source data by an encoder provided in the computer **10**.

The quality relating to the transmission of source data becomes higher as the amount of transmission data generated from the source data increases. The connection control program controls the operation of the encoder, thereby varying the quality relating to the transmission of source data. The generated transmission data is sent from the computer **10** to headset **20** as an audio stream.

The headset **20** is an output device that reproduces an audio stream of music, voice, etc., which is sent from the computer **10** by radio, and generates sound corresponding to the audio data of the audio stream. In the headset **20**, the audio stream sent from the computer **10** is decoded and the decoded audio stream is reproduced.

The headset has a microphone **205**. A signal of voice of the user, which is input from the microphone **25**, is transmitted by radio to the computer **10**.

The headset **20** is configured to be wearable on the head of the user. The headset **20**, as shown in FIG. 1, comprises a head arm **201**, and two ear pads **202** and **203** provided at both ends of the head arm **201**. Each ear pad **202**, **203** incorporates a speaker. Each ear pad **202**, **203** functions as a speaker unit.

In the state in which the headset **20** is worn on the head of the user, the two ear pads **202** and **203** cover the right and left ears of the user. One end of a microphone arm **204** is attached to the pad **202**, and the other end thereof is provided with the microphone **205**.

Next, the system configuration of the computer **10** is described referring to FIG. 2.

The computer **10**, as shown in FIG. 2, comprises a CPU **101**, a host bridge **102**, a main memory **103**, a display controller **104**, a system controller **105**, a hard disk drive (HDD) **106**, a CD/DVD drive **107**, a wireless communication device

4

108, a sound controller **110**, an audio amplifier **111**, a speaker **112**, a modem **113**, a LAN controller **114**, a BIOS-ROM **115**, and an embedded controller/keyboard controller IC (EC/KBC) **116**.

The CPU **101** is a processor provided to control the operations of the computer **10**. The CPU **101** executes an operating system (OS) **301** and various application/utility programs, which are loaded in the main memory **103** from the hard disk drive (HDD) **106**. The CPU **101** also executes a BIOS (Basic Input/Output System) stored in the BIOS-ROM **115**.

In the computer **10**, the aforementioned connection control program **302** is pre-installed as one of the utility programs. In addition, an audio player **303** is installed as an application program for reproducing audio data.

Using a quality definition table **300** as shown in FIG. 3, the connection control program **302** determines an optimal transmission quality that is suited to source data to be reproduced. The quality definition table **300** prestores definition information indicative of whether high-quality transmission is necessary or not in association with each type (S=1 to 5) of source data. In the quality definition table **300** shown in FIG. 3, “○” designates source data requiring high-quality transmission, and “X” designates source data requiring only low-quality transmission. The value (S) is used as an index for searching the quality definition table **300**.

In the present embodiment, the type of source data is classified according to the type of input device (disk drives and Internet-connection communication devices) that inputs source data to be reproduced by the headset **20**.

Normally, audio data stored in storage media such as CDs/DVDs is high-quality data that is specifically used for music, which is sampled at a high sampling frequency. On the other hand, the quality of audio data stored in the HDD is, in many cases, not so high. Thus, the connection control program **302** classifies the type of source data according to the type of disk drive in which the source data to be reproduced by the headset **20** is stored.

In addition, in the case where audio data such as music data, which is present on Web sites on the Internet **60**, is used as source data, the connection control program **302** classifies the type of the source data (data requiring high-quality transmission or data requiring only low-quality transmission) according to whether the communication line for connection to the Internet **60** is a broadband high-speed line or a narrow-band low-speed line.

In this way, in accordance with the type of input device for inputting source data, the optimal transmission quality for the source data is determined.

In practice, in order to prevent adverse effect on communication between the computer **10** and a device other than the headset **20**, the connection control program **302** determines the quality with which source data is to be transmitted, taking into account not only the type of the source data to be sent to the headset **20**, but also the number of devices (number of links) currently wirelessly connected to the computer **10** and the establishment/non-establishment of the link with the camera **40**.

If high-quality transmission of audio data to the headset **20** is started in the state in which video data such as motion video is being transmitted from the camera **40** to the computer **10**, faults such as halt of video data transmission or halt of audio data transmission may occur. In the present embodiment, when the number of links is relatively large or when the link between the camera **40** and computer **10** is established, the transmission quality of audio data is set at a low level.

In FIG. 2, the host bridge **102** is a bridge device that connects the local bus of the CPU **101** and the system con-

US 7,460,477 B2

5

troller **105**. The host bridge **102** includes a memory controller that controls access to the main memory **103**. The display controller **104** controls the LCD **121** that is used as a display monitor of the computer **10**.

The system controller **105** controls each device on a PCI (Peripheral Component Interconnect) bus **1** and each device on an ISA (Industry Standard Architecture) bus **2**. The system controller **105** includes an IDE (Integrated Drive Electronics) controller for controlling the HDD **106** and CD/DVD drive **107**. The system controller **105** also includes a USB (Universal Serial Bus) controller **200**. The wireless communication device **108** is connected to the USB controller **200**.

The wireless communication device **108** is a device for executing wireless communication and includes a baseband unit and an RF (Radio Frequency) unit. The RF unit performs transmission/reception of a radio signal via an antenna (ANT) **109**. The wireless communication device **108** is configured to execute wireless communication according to Bluetooth™ standards.

The sound controller **110** is a device for reproducing audio data. An audio signal output from the sound controller **110** is delivered to the speaker **112** via the audio amplifier (AMP) **111**. The speaker **112** produces the audio signal as sound. The modem **113** and LAN controller **114** are wired communication devices capable of communicating with the Internet **60**. The modem **113** is used to connect the computer **10** to the Internet **60** via a narrowband low-speed communication line such as a telephone line. The LAN controller **114** is used to connect the computer **10** to the Internet **60** via a broadband high-speed communication line such as an xDSL or CATV. The LAN controller **114** is connected to the xDSL or CATV via the modem **50** designed for the xDSL or CATV.

The embedded controller/keyboard controller IC (EC/KBC) **116** is a one-chip microcomputer in which an embedded controller for power management and a keyboard controller for controlling the keyboard (KB) **13** and touch pad **15** are integrated. The keyboard (KB) **13** and touch pad **15** are user interface units that can be operated by the user. In addition, the embedded controller/keyboard controller IC (EC/KBC) **116** has a function of powering on/off the computer **10** in accordance with the operation of the power button **14** by the user.

FIG. 4 shows an example of an operation screen **70** that is displayed on the LCD **121** by the audio player **303**.

The operation screen **70** is a window that prompts the user to select audio data to be reproduced. The operation screen **70** contains an [HDD] tab **71**, a [CD/DVD] tab **72**, an [INTERNET] tab **73**, and a [PLAY] button **75**.

If the user clicks the [HDD] tab **71**, a source data list **74** that presents audio data items stored in the HDD **106** is displayed. The source data list **74** displays the song title, artist name, and album title for each of audio data. The user can select audio data to be reproduced, from the source data list **74**. Similarly, when the user clicks the [CD/DVD] tab **72**, a source data list that presents audio data items stored in the CD/DVD drive **107** is displayed. When the user clicks the [INTERNET] tab **73**, a source data list that presents audio data items stored on a specific Web site on the Internet **60** is displayed.

When the [PLAY] button **75** is clicked, the audio player **303** starts reproduction of audio data selected from the source data list. The connection control program **302** cooperates with the audio player **303** and executes a process for transmitting a stream of the selected audio data to the headset **20** with a transmission quality corresponding to the type of the selected audio data.

The scheme of software for controlling the wireless communication device **108** is described referring to FIG. 5.

6

The wireless communication device **108** comprises a hardware logic (baseband unit **504** and RF unit **505**) and firmware for controlling the hardware logic. The firmware includes a BUS driver **501**, an HCI (Host Control Interface) driver **502**, and an LMP (Link Management Protocol) **503**. The BUS driver **501** is a driver for connecting the wireless communication device **108** to a bus such as a USB. The HCI driver **502** is a driver for communication with the host (computer **10**) via the BUS driver **501**. The LMP **503** is a driver for controlling a physical wireless link.

As programs for controlling the wireless communication device **108**, protocol drivers **307** that constitute a protocol stack, as well as the aforementioned connection control program **302**, are installed in the computer **10**.

The protocol drivers **307** include an AV (audio/video) protocol driver **401** for executing an A2DP function, an HCI driver **402** for executing communication with the wireless communication device **108**, and a BUS driver **403** for controlling the bus such as a USB, to which the wireless communication device **108** is connected.

The connection control program **302** controls the wireless communication device **108** via the protocol drivers **307**, thereby controlling transmission of an audio data stream between the headset **20** and computer **10**. The connection control program **302** can acquire, through the operating system (OS) **301** or audio player **303**, information indicative of the type of the input device for inputting source data to be reproduced (i.e. the type of disk drive in which the source data is stored, or the type of communication device for receiving the source data from the Internet). The connection control program **302** determines the transmission quality of source data in accordance with the type of input device, by referring to the quality definition table **300**.

In the connection establishing process for streaming, the connection control program **302** sets communication conditions associated with the determined transmission quality in the computer **10** and headset **20** in accordance with the content of an environment setting information file **306**.

The setting of the communication conditions is executed using predetermined parameter information associated with the high-quality transmission and low-quality transmission. The parameter information is information for controlling the data amount of transmission data to be generated, and it includes various parameter values such as the kind of CODEC (COmpression/DECompression) to be applied to source data that is to be transmitted, and the value of sampling frequency used in the CODEC.

The parameter indicative of the kind of CODEC designates a compression-encoding scheme by which the source data to be transmitted is compressed and encoded. This parameter is set in an encoder provided in the computer **10** and in a decoder provided in the headset **20**. The parameter indicative of the value of sampling frequency designates a sampling frequency with which source data to be transmitted should be sampled in the encoding of the source data. This parameter, too, is set in the encoder provided in the computer **10** and in the decoder provided in the headset **20**.

The environment setting information file **306** prestores parameter information corresponding to the communication conditions for realizing high-quality transmission (e.g. the kind of compression-encoding scheme applied to source data, and the value of sampling frequency), and parameter information corresponding to the communication conditions for realizing low-quality transmission (e.g. the kind of compression-encoding scheme applied to source data, and the value of sampling frequency).

US 7,460,477 B2

7

In the high-quality streaming, for example, low-compression SBC (Subband Codec) is used. SBC is a compression-encoding/decoding scheme for music data, and a relatively large amount of arithmetic operations are needed for the processing of SBC. SBC, however, realizes sound reproduction with a sufficiently high quality on the receiving side.

In the low-quality streaming, SBC or μ -law is used. The value of sampling frequency used in SBC in the low-quality streaming is lower than the value of sampling frequency used in SBC in the high-quality streaming.

As has been described above, the parameter values such as the kind of CODEC and the sampling frequency are varied according to the quality with which the source data is to be transmitted. As a result, the data amount of transmission data (the bit rate of transmission data), which is generated from the source data, is changed. Accordingly, the wireless communication bandwidth required for transmitting source data is varied in accordance with the type of the source data.

A network driver 308 is a driver program for controlling the modem 113 or LAN controller 114 under control of the OS 301. Audio data, which is transferred by streaming from a Web site on the Internet 60, is sent to the audio player 303 via the network driver 308 and OS 301. A CD/DVD driver 309 is a driver program for controlling the CD/DVD drive 107 under control of the OS 301. Audio data, which is read out of the CD/DVD drive 107, is sent to the audio player 303 via the CD/DVD driver 309 and OS 301. An HDD driver 310 is a driver program for controlling the HDD 106 under control of the OS 301. Audio data, which is read out of the HDD 106, is sent to the audio player 303 via the HDD driver 310 and OS 301.

Audio data reproduced by the audio player 303 is delivered to a first sound driver 304 or a second sound driver 305 via the OS 301. The first sound driver 304 is a driver for controlling the sound controller 110. The first sound driver 304 is used to produce sound from the built-in speaker 112 via the sound controller 110. The second sound driver 305 is a driver for transmitting audio data to the wireless communication device 108 via the protocol drivers 307.

The connection control program 302 loads the second sound driver 305 in the main memory 103, thereby to send audio data to the headset 20 by radio. The second sound driver 305 has a higher priority than the first sound driver 304.

After the second sound driver 305 is loaded, the second sound driver 305, in place of the first sound driver 304, is used by the OS 301. Accordingly, audio data reproduced by the audio player 303 is sent to the second sound driver 305 as source data to be reproduced by the headset 20.

The second sound driver 305 has a CODEC 600 associated with both SBC and μ -law. The CODEC 600 includes an encoder, which encodes source data using SBC or μ -law and generates transmission data, and a decoder that decodes transmission data using SBC and μ -law.

The second sound driver 305 encodes source data (audio data) to be transmitted, using a compression-encoding scheme designated by the connection control program 302. The value of sampling frequency used in the compression-encoding process is also designated by the connection control program 302. By the encoding process, the source data is converted to transmission data.

Referring now to FIG. 6, the system configuration of the headset 20 is described.

The headset 20, as shown in FIG. 6, comprises a wireless communication device 701, a system controller 702, an audio reproducing unit 703, and an audio input unit 704.

The system controller 702 is a processor provided to control the operations of the headset 20. The system controller

8

702 controls the wireless communication device 701, audio reproducing unit 703 and audio input unit 704. The system controller 702 includes a CODEC 801 associated with both SBC and μ -law. The CODEC 801 includes a decoder that decodes transmission data received as an audio stream, using SBC and μ -law, and an encoder that encodes an input voice signal from the microphone 205, using SBC and μ -law, and generates transmission data.

The wireless communication device 701, like the wireless communication device 108 of computer 10, executes wireless communication on the basis of a procedure according to Bluetooth™ standards.

The audio reproducing unit 703 executes a data reproduction process for streaming reproduction. That is, in this process, while receiving an audio data stream sent from the computer 10 via the wireless communication device 701 and system controller 702, the audio reproducing unit 703 converts the audio data stream to an electric signal that can be output as sound from a speaker 206 built in each pad 202, 203. The audio input unit 704 converts an analog voice signal input from the microphone 205 to a digital signal, and delivers it to the system controller 702.

FIG. 7 illustrates a connection establishing process that is executed by the connection control program 302.

The connection control program 302 controls the wireless communication device 108 of the computer 10, thereby starting the connection establishing process. In the connection establishing process, a procedure is executed for establishing a channel (transport channel) for transmitting audio data such as music from the computer 10 to the headset 20.

In the connection establishing process, the connection control program 302 sets communication conditions, which correspond to the transmission quality determined according to the type of source data, in both the computer 10 and headset 20 that are to function as stream end points of the transport channel. In this case, in practice, the connection control program 302 detects the capability of the headset 20 by executing negotiation with the headset 20. Based on the detected capability of the headset 20 and the communication conditions corresponding to the determined transmission quality, the connection control program 302 determines optimal communication conditions that are to be actually used in the data streaming between the computer 10 and headset 20, and sets the optimal communication conditions in the CODEC 600 of computer 10 and the CODEC 801 of headset 20.

The computer 10 functions as a source device for transmitting audio data via the established transport channel. The headset 20 functions as a sink device for receiving audio data that is transmitted via the established transport channel. Following the connection establishing process, a process (streaming) for transmitting audio data from the computer 10 to the headset 20 is started.

The procedure of a transmission quality determination process that is executed by the connection control program 302 will now be described with reference to a flow chart of FIG. 8.

The connection control program 302 executes the following transmission quality determination, for example, when the [PLAY] button 75 on the operation screen 70 shown in FIG. 4 is clicked.

To start with, the connection control program 302 determines whether the camera 40 is wirelessly connected to the computer 10, that is, whether a link between the wireless communication device 108 and camera 40 is established (step S101). If the camera 40 is wirelessly connected to the computer 10 (YES in step S101), the connection control program 302 determines a low quality as the quality for transmission of audio data to be reproduced, which is selected on the opera-

US 7,460,477 B2

9

tion screen **70** (step **S102**). Thus, the transmission of image data such as moving image between the camera **40** and the computer **10** is executed with priority over transmission of the audio data from the computer **10** to the headset **20**.

If the camera **40** is not wirelessly connected to the computer **10** (NO in step **S101**), the connection control program **302** determines whether the number of devices (number of links) currently wirelessly connected to the computer **10** is a predetermined number (n) or more (step **S103**). If the number of links is n or more, the connection control program **302** determines a low quality as the quality for transmission of audio data to be reproduced (step **S102**). The default value of n is, e.g. 3. The value n can be varied by the user.

If the number of links is less than n , the connection control program **302** detects the type of audio data to be reproduced, that is, the type of input device used for inputting audio data to be reproduced.

Specifically, the connection control program **302** determines whether the audio data to be reproduced is audio data stored in the HDD **106** (step **S104**). If the audio data to be reproduced is the data stored in the HDD **106** (YES in step **S104**), the connection control program **302** sets $S=1$ (step **S105**). If the audio data to be reproduced is not data stored in the HDD **106** (NO in step **S104**), the connection control program **302** determines whether the audio data to be reproduced is audio data stored in the CD/DVD drive **107** (step **S106**).

If the audio data to be reproduced is the audio data stored in the CD/DVD drive **107** (YES in step **S106**), the connection control program **302** sets $S=2$ (step **S107**). If the audio data to be reproduced is not data stored in the CD/DVD drive **107** (NO in step **S106**), the connection control program **302** determines whether the audio data to be reproduced is audio data stored on a Web site on the Internet **60** (step **S108**). If the audio data to be reproduced is audio data stored on the Web site on the Internet **60**, that is, audio data transferred from the Internet **60** (YES in step **S108**), the connection control program **302** asks the OS **301** whether the communication device currently used for connection to the Internet **60** is the modem **113** or LAN controller **114**, thereby determining whether the communication line currently used for connection to the Internet **60** is a high-speed line (step **S109**). If the communication line is the high-speed line (YES in step **S109**), the connection control program **302** sets $S=3$ (step **S111**). If the communication line is a low-speed line (NO in step **S109**), the connection control program **302** sets $S=4$ (step **S110**).

If the audio data to be reproduced is not data transferred from the Internet **60** (NO in step **S108**), the connection control program **302** sets $S=5$ (step **S112**).

Then, the connection control program **302** searches the quality definition table **300** using the set value S as an index, thereby determining the quality with which the audio data to be reproduced is to be transmitted (step **S113**).

Next, a connection control process that is executed by the connection control program **302** is described with reference to a flow chart of FIG. **9**.

After determining the quality with which the to-be-reproduced audio data is to be transmitted, the connection control program **302** executes the following connection control process in order to establish the transport channel for transmitting audio data from the computer **10** to the headset **20** with the determined quality.

In order to set a communication environment for wirelessly transmitting audio data to the headset **20** with the determined quality, the connection control program **302** starts the connection establishing process. In the connection establishing process, the connection control program **302** sets communi-

10

cation conditions (the kind of CODEC and the value of sampling frequency), which correspond to the quality determined by the process of FIG. **8**, in the computer **10** and headset **20** that are to function as stream end points of the transfer channel (step **S201**). Specifically, the parameter information including the kind of CODEC and the value of sampling frequency is set in the CODEC **600** of the computer **10** and in the CODEC **801** of the headset **20**. The setting of the communication conditions is effected via a control channel that is established between the computer **10** and headset **20**.

The role of the sink device is assigned to the remote device, that is, the headset **20**. The role of the source device is assigned to the local device, that is, the computer **10**. The processing in step **S201** establishes the transport channel for transmitting audio data such as music from the computer **10** to the headset **20** with the determined quality.

Then, the connection control program **302** loads the second sound driver **305** (step **S202**), and informs the headset **20** of the start of streaming, thus executing a streaming process (step **S203**). In step **S203**, transmission data (audio stream) is generated from source data such as music or voice by the CODEC **600**, and the audio stream is wirelessly transmitted from the computer **10** to the headset **20**.

As has been described above, according to the present embodiment, the transmission quality, with which source data that is to be reproduced by the headset **20** is to be transmitted, is automatically optimized according to the kind of the source data. Therefore, the source data to be reproduced, such as music, can efficiently be wirelessly transmitted, without occupying the entirety of the wireless communication bandwidth of Bluetooth™. Moreover, the quality for transmitting the source data is determined by also taking into account the number of links and the connection/disconnection of the camera **40**. Thus, the source data to be reproduced, such as music, can be transmitted to the headset **20**, without adversely affecting wireless communication between the computer **10** and a device other than the headset **20**.

All the quality determination process and connection control process are realized by the computer program. Therefore, the same advantages as with the present embodiment can easily be obtained by simply installing the computer program in a computer with a wireless communication function, using a computer-readable storage medium storing this computer program.

Additional advantages and modifications will readily occur to those skilled in the art. Therefore, the invention in its broader aspects is not limited to the specific details and representative embodiments shown and described herein. Accordingly, various modifications may be made without departing from the spirit or scope of the general inventive concept as defined by the appended claims and their equivalents.

What is claimed is:

1. An electronic apparatus comprising:

an encoder that encodes source data to generate transmission data;

a wireless communication device that executes communication with an external device via a wireless network, and transmits the transmission data generated by the encoder to the external device;

means for detecting the number of devices connected to the wireless communication device via the wireless network;

means for determining a rate at which the source data is to be transmitted, on the basis of the detected number of devices and a type of the source data, wherein when the detected number is greater than a preset value, the rate is

US 7,460,477 B2

11

determined lower than when the detected number is not greater than the preset value; and
 means for controlling the encoder to vary an amount of the generated transmission data on the basis of the determined rate of the source data.

2. The electronic apparatus according to claim 1, wherein the controlling means includes means for setting in the encoder a value of sampling frequency, which is to be used in the encoding of the source data, in accordance with the determined rate of the source data.

3. The electronic apparatus according to claim 1, wherein the controlling means includes means for setting in the encoder a kind of an encoding scheme, which is to be used in the encoding of the source data, in accordance with the determined rate of the source data.

4. The electronic apparatus according to claim 1, wherein the controlling means includes means for setting in the encoder a kind of an encoding scheme, which is to be used in the encoding of the source data, and a value of sampling frequency, which is to be used in the encoding of the source data, in accordance with the determined rate of the source data.

5. The electronic apparatus according to claim 1, further comprising a plurality of input devices capable of inputting data,
 wherein the rate determining means includes means for detecting the type of the source data by determining from which of the input devices the source data is input.

6. The electronic apparatus according to claim 1, wherein: the source data includes audio data,
 the electronic apparatus further includes means for determining whether a device that transmits image data is connected to the wireless communication device via the wireless network, and
 the rate determining means includes means for setting, when the device that transmits image data is connected to the wireless communication device, the rate of the source data at a first rate which is lower than a given rate.

7. A program that is stored in a computer-readable medium and controls wireless communication for transmitting transmission data, which is generated by encoding source data, from a computer to an external device via a wireless network, comprising:
 causing the computer to execute a process of detecting the number of devices connected to the computer via the wireless network;

12

causing the computer to determine a rate at which the source data is to be transmitted, on the basis of the detected number of devices and a type of the source data, wherein when the detected number is greater than a preset value, the rate is determined lower than when the detected number is not greater than the preset value; and causing the computer to execute a process of controlling an operation of the encoding to vary an amount of the generated transmission data on the basis of the determined rate of the source data.

8. The program according to claim 7, wherein said causing the computer to execute the process of controlling the operation of the encoding includes causing the computer to execute a process of determining a value of sampling frequency, which is to be used in the encoding process, in accordance with the determined rate of the source data.

9. The program according to claim 7, wherein said causing the computer to execute the process of controlling the operation of the encoding includes causing the computer to a process of determining a kind of an encoding scheme, which is to be used in the encoding process, in accordance with the determined rate of the source data.

10. The program according to claim 7, wherein said causing the computer to execute the process of controlling the operation of the encoding includes causing the computer to execute a process of determining a kind of an encoding scheme, which is to be used in the encoding process, and a value of sampling frequency, which is to be used in the encoding process, in accordance with the determined rate of the source data.

11. The program according to claim 7, wherein said causing the computer to determine the rate includes causing the computer to execute a process of detecting the type of the source data by determining from which of a plurality of input devices of the computer the source data is input.

12. The program according to claim 7, wherein:
 the source data includes audio data,
 the program further includes causing the computer to execute a process of determining whether a device that transmits image data is connected to the computer via the wireless network, and
 said causing the computer to determine the rate includes causing the computer to execute a process of setting, when the device that transmits image data is connected to the wireless communication device, the rate of the source data at a first rate which is lower than a given rate.

* * * * *

UNITED STATES PATENT AND TRADEMARK OFFICE
CERTIFICATE OF CORRECTION

PATENT NO. : 7,460,477 B2
APPLICATION NO. : 10/795974
DATED : December 2, 2008
INVENTOR(S) : Yata et al.

Page 1 of 1

It is certified that error appears in the above-identified patent and that said Letters Patent is hereby corrected as shown below:

Claim 9, column 12, line 19, change "to a" to --to execute a--.

Signed and Sealed this

Third Day of March, 2009

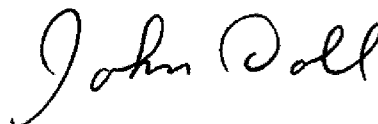

JOHN DOLL
Acting Director of the United States Patent and Trademark Office

EXHIBIT 10

TP-Link WiFi Routers



AC1200 Wireless Dual Band Router

Archer C50 V5

- Supports 802.11ac standard
- Simultaneous 2.4GHz 300 Mbps and 5GHz 867 Mbps connections for 1200 Mbps of total available bandwidth
- 2 external antennas provide stable wireless connections and optimal coverage
- Easy network management at your fingertips with TP-Link Tether
- Supports IGMP Proxy/Snooping, Bridge and Tag VLAN to optimize IPTV streaming
- Supports Access Point mode to create a new Wi-Fi access point

7. A program that is stored in a computer-readable medium and controls wireless communication for transmitting transmission data, which is generated by encoding source data, from a computer to an external device via a wireless network, comprising:

causing the computer to execute a process of detecting the number of devices connected to the computer via the wireless network;

causing the computer to determine a rate at which the source data is to be transmitted, on the basis of the detected number of devices and a type of the source data, wherein when the detected number is greater than a preset value, the rate is determined lower than when the detected number is not greater than the preset value; and

causing the computer to execute a process of controlling an operation of the encoding to vary an amount of the generated transmission data on the basis of the determined rate of the source data.

Claim 7

A program that is stored in a computer-readable medium and controls wireless communication for transmitting transmission data, which is generated by encoding source data, from a computer to an external device via a wireless network, comprising:

Source: <https://www.microcontrollertips.com/teardown-inside-TP-Link-archer-c7-wireless-router/>

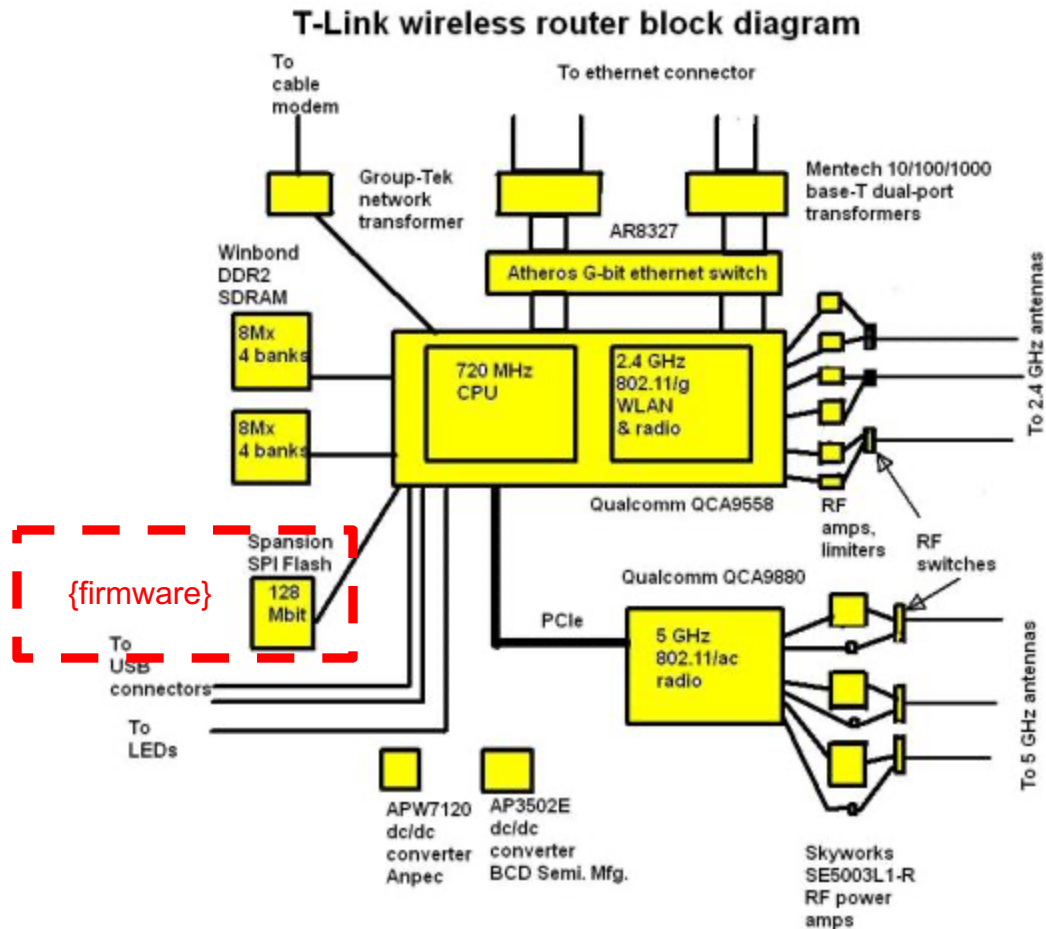

Claim 7

A program that is stored in a computer-readable medium and controls wireless communication for transmitting transmission data, which is generated by encoding source data, from a computer to an external device via a wireless network, comprising:

Source: <https://www.microcontrollertips.com/teardown-inside-TP-Link-archer-c7-wireless-router/>

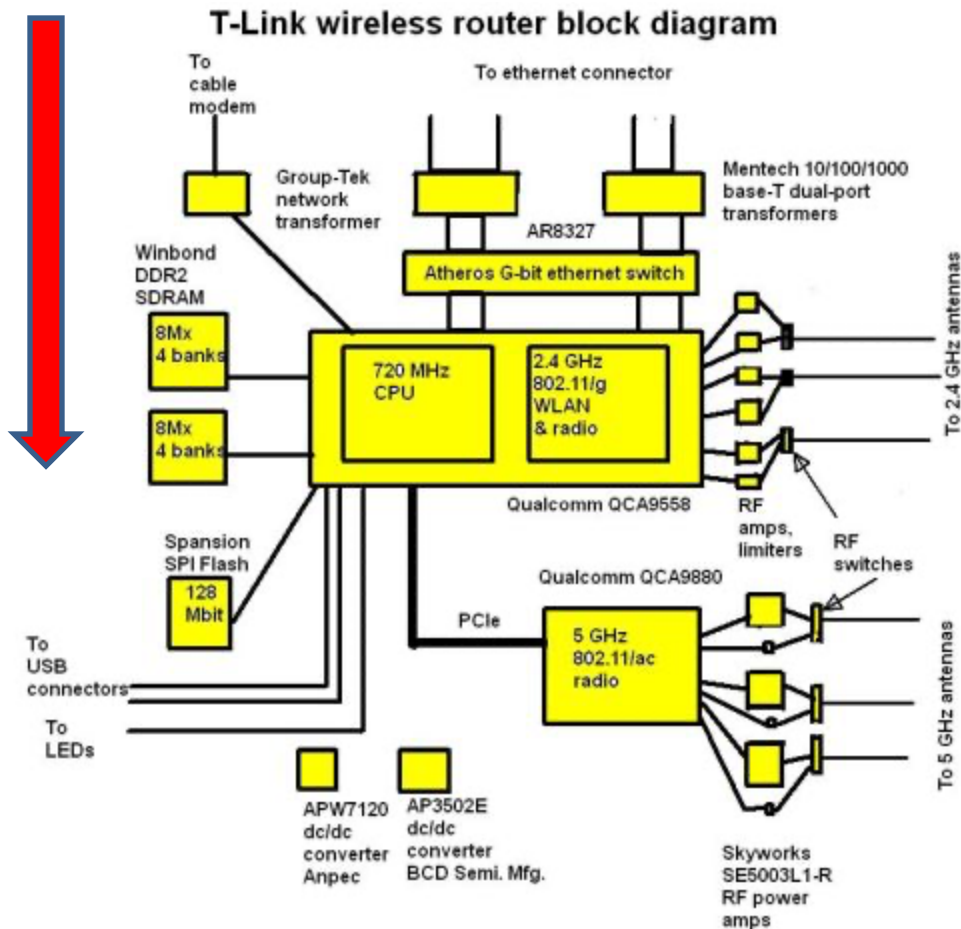

Claim 7

A program that is stored in a computer-readable medium and controls wireless communication for transmitting transmission data, which is generated by encoding source data, from a computer to an external device via a wireless network, comprising:

4. 4. Configure the Router in Access Point Mode

In this mode, your router connects to a wired or wireless router via an Ethernet cable and extends the wireless coverage of your existing network. Advanced functions like NAT, Parental Controls and QoS are not supported in this mode.

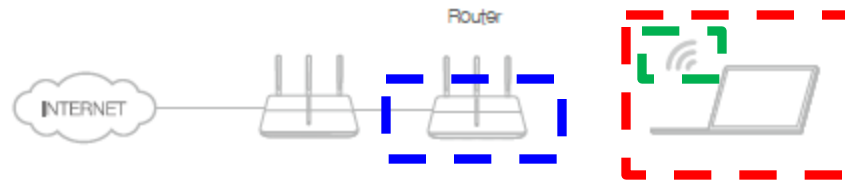

https://static.tp-link.com/2018/201802/20180224/1910012180_Archer%20C1200_UG.pdf

Page 19

Claim 7

causing the computer to execute a process of detecting the number of devices connected to the computer via the wireless network;

Source: <https://www.tp-link.com/us/support/faq/1104/>

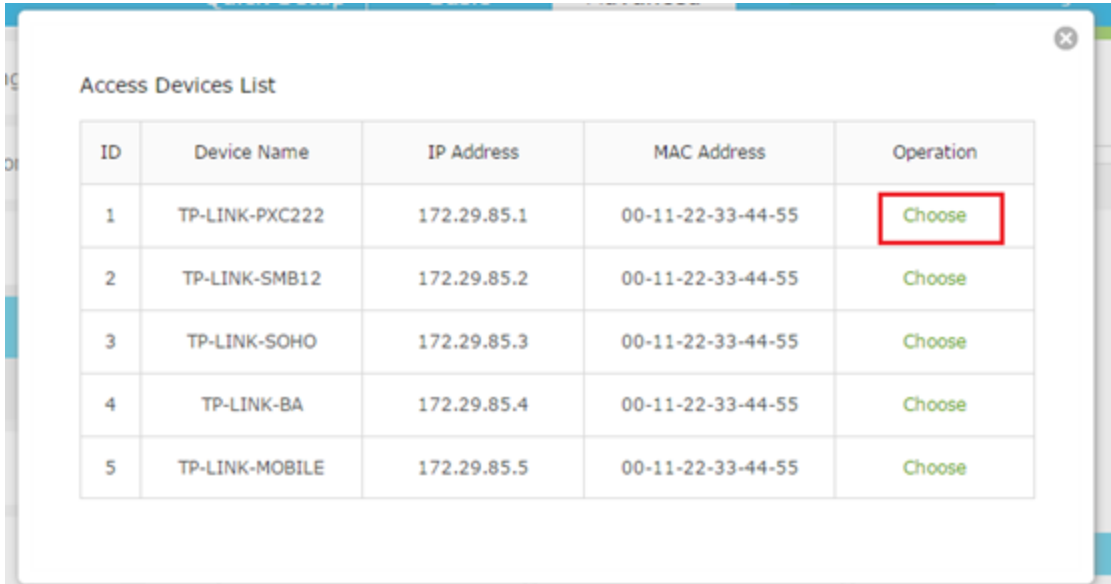

The screenshot shows a web interface titled "Access Devices List" with a table containing five rows of device information. The first row's "Choose" button is highlighted with a red box. The table is enclosed in a dashed magenta border.

ID	Device Name	IP Address	MAC Address	Operation
1	TP-LINK-PXC222	172.29.85.1	00-11-22-33-44-55	Choose
2	TP-LINK-SMB12	172.29.85.2	00-11-22-33-44-55	Choose
3	TP-LINK-SOHO	172.29.85.3	00-11-22-33-44-55	Choose
4	TP-LINK-BA	172.29.85.4	00-11-22-33-44-55	Choose
5	TP-LINK-MOBILE	172.29.85.5	00-11-22-33-44-55	Choose

Claim 7

causing the computer to determine a rate at which the source data is to be transmitted, on the basis of the detected number of devices and a type of the source data

Source: https://static.tp-link.com/2018/201802/20180224/1910012180_Archer%20C1200_UG.pdf pg 43

QoS

Enable QoS

Upload Bandwidth: 1000 Mbps

Download Bandwidth: 1000 Mbps

Advanced

High Priority: 60%

Middle Priority: 30%

Low Priority: 10%

Save

Claim 7

causing the computer to determine a rate at which the source data is to be transmitted, on the basis of the detected number of devices and a type of the source data

2) Set a middle priority rule for the phone.

a. Click **Add** in the Middle Priority section.

b. Select **By Device** and then click **View Existing Devices**.

QoS Rule

Type: By Device By Application

Device Name: **View Existing Devices**

MAC Address:

Cancel OK

Source: <https://www.tp-link.com/us/support/faq/1104/>

c. Choose the respective device from the list.

ID	Device Name	IP Address	MAC Address	Operation
1	TP-LINK-PXC222	172.29.85.1	00-11-22-33-44-55	Choose
2	TP-LINK-SMB12	172.29.85.2	00-11-22-33-44-55	Choose

Then the QoS rules list will display in the table.

d. Click **OK**.

QoS Rule

Type: By Device

Device Name: TP-LINK-PXC222 **View Existing Devices**

MAC Address: 00-11-22-33-44-55

Cancel **OK**

QoS Rule List

Priority	Rule Name	Operation
High Priority: 60%	FTP	Trash
Middle Priority: 30%	TP LINK PXC222	Trash

{Note: Example from TP-Link shows one detected device, but routers can have more}

Claim 7

causing the computer to determine a rate at which the source data is to be transmitted, on the basis of the detected number of devices and a type of the source data

Source: <https://www.tp-link.com/us/support/fag/1104/>

- 1) Set a high priority rule for the ftp server.
 - a. Click **Add** in the High Priority section.
 - b. Select **By Application** and then select **ftp** in the list. Click **OK**.

QoS Rule

Type: By Device By Application

Application

<input type="checkbox"/> SSH	<input type="checkbox"/> BT	<input type="checkbox"/> SMTP
<input type="checkbox"/> Telnet	<input type="checkbox"/> Emule	<input type="checkbox"/> POP3
<input type="checkbox"/> VPN	<input type="checkbox"/> Facebook	<input checked="" type="checkbox"/> FTP
<input type="checkbox"/> WWW	<input type="checkbox"/> Vonage	<input type="checkbox"/> PPTP
<input type="checkbox"/> DNS	<input type="checkbox"/> netTalk	<input type="checkbox"/> L2TP
<input type="checkbox"/> ICMP	<input type="checkbox"/> iTalkBB	<input type="checkbox"/> IPsec
<input type="checkbox"/> NNTP	<input type="checkbox"/> GTalk	<input type="checkbox"/> WhatsApp
<input type="checkbox"/> MSN	<input type="checkbox"/> HTTP	
<input type="checkbox"/> Skype	<input type="checkbox"/> HTTPS	

Custom Application >

Cancel OK

Then the QoS rules list will display in the table.

High Priority:60%	Middle Priority:30%
FTP	TP LINK PXC222

Claim 7

wherein when the detected number is greater than a preset value, the rate is determined lower than when the detected number is not greater than the preset value; and

Source: <https://community.tp-link.com/us/home/forum/topic/161574?replyId=328672>

Pretty simple QoS question, untagged traffic priority?

2019-05-23 08:41:29

... What about traffic from an IP not listed in the table (so called 'bulk' traffic)? Does bulk traffic automatically get tagged as 'low priority'? ...

{Note: "preset value" would be count of all devices allocated priority higher than "low", which is one in this example from TP-Link.}

High Priority:60%	Middle Priority:30%	Low Priority:10%
FTP	TP LINK PKG212	
Add	Add	Add



TP-Link Tony

2019-05-24 09:58:40

Re:Pretty simple QoS question, untagged traffic priority?

@mscully

The way you explained QoS is pretty much on point.

With respect to your question about devices not on the QoS list. By default they will work as if they were on low priority.

Claim 7

wherein when the detected number is greater than a preset value, the rate is determined lower than when the detected number is not greater than the preset value; and

Source: <https://www.tp-link.com/us/support/fag/1104/>

{Note: With # of devices=preset value, the rate is determined higher}

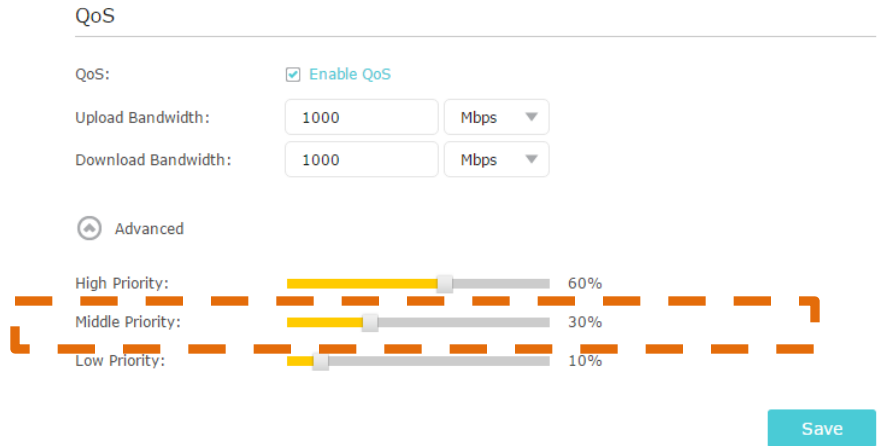
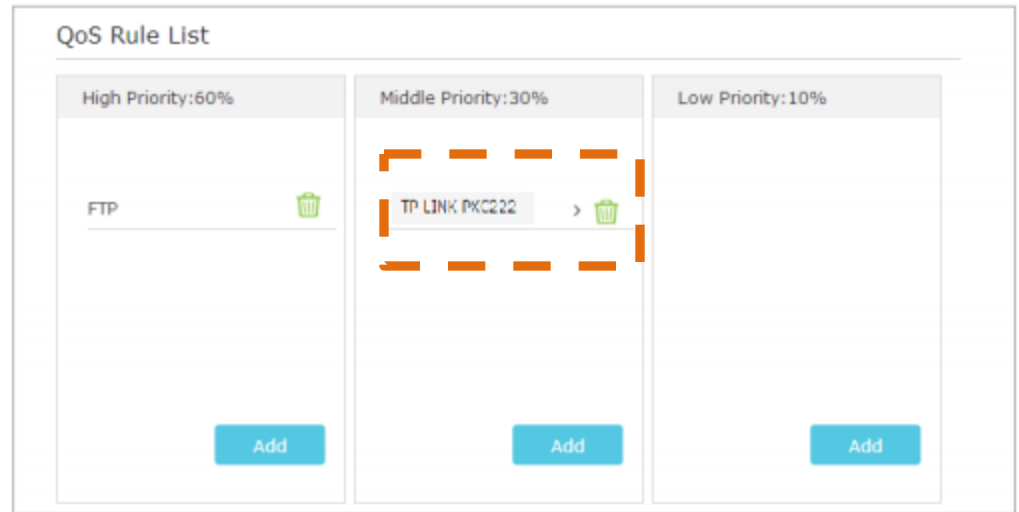

Claim 7

causing the computer to execute a process of controlling an operation of the encoding to vary an amount of the generated transmission data on the basis of the determined rate of the source data.

Source: <https://www.tp-link.com/us/support/faq/1104/>

Why do we need QoS?

QoS (Quality of Service), is designed to ensure the efficient operation of the network when the network overload or congest. It can specify priority of traffic and minimize the impact caused when the connection is under heavy load.

How to configure QoS?

Scenario:

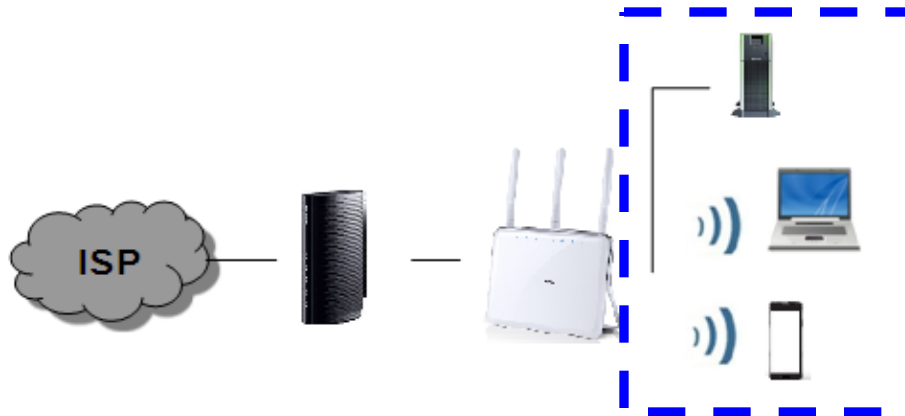

For example, I have several devices that are connected to my wireless network.

I would like to:

- Set my ftp server with faster surfing speed;
- Set my phone with intermediate speed on the Internet.

EXHIBIT 11

Patent 6,885,643
Claim 1

Product	WiFi Certified Model	Alternate Model Name
AC1350 Wireless Dual Band Gigabit Router	EC230-G1	Archer C60, Archer C59, Archer C58
AC1200 Wireless Dual Band Gigabit Router	Archer C1210	
AC1750 Wireless Dual Band Gigabit Router	C7	
AC1200 Wireless Dual Band Gigabit VoIP VDSL/ADSL Modem Router	Archer VR500v	
AC1200 Wireless Dual Band Gigabit Router	Archer C5	
AC1900 Wireless Dual Band Gigabit Router	EC330-G5u	
AC1200 Wireless Dual Band Gigabit VoIP VDSL/ADSL Modem Router	VC221-G3v	C6
AC1900 Wireless Dual Band Gigabit Router	C9	
AC1750 Wireless Dual Band Gigabit Router	C8	Archer A7, Archer C7, Archer C8
AC1200 Wireless Dual Band Gigabit VoIP VDSL/ADSL Modem Router	Archer VR1200v	
AC1200 Wireless Dual Band Gigabit Router	Archer C1200	
AC1200 Wireless Dual Band Gigabit Router	Archer C5	
AC1900 Touch Screen Wi-Fi Gigabit Router	Touch P5	
AC1200 Whole Home Mesh Wi-Fi System	HC221-G1	
AC900 Wireless Dual Band Router		Archer C25
AC5200 Wireless Tri-Band MU-MIMO Gigabit Router		Archer C5200
AC5400 Wireless Tri-Band MU-MIMO Gigabit Router		Archer C5400
Talon AD7200 Multi-Band Wi-Fi Router		AD7200
AC3000 Wireless Tri-Band Gigabit Router		Archer C3000
AC2600 Wireless Dual Band Gigabit Router		Archer C2600
AC750 Wireless Dual Band Gigabit Router		Archer C2, TL-WR902AC
AX11000 Next-Gen Tri-Band Gaming Router		Archer AX11000
AX6000 Next-Gen Wi-Fi Router		Archer AX6000
AX3000 Dual Band Gigabit Wi-Fi 6 Router		Archer AX50
AX3000 Dual Band Gigabit Wi-Fi 6 Router		Archer AX3000

AX1500 Wi-Fi 6 Router

Archer AX10

AX1500 Wi-Fi 6 Router

Archer AX1500

AC4000 MU-MIMO Tri-Band Wi-Fi Router

Archer C4000, Archer A20

AC2300 Wireless MU-MIMO Gigabit Router

Archer C2300

Patent **6,928,166**
Claim **13**

Product**WiFi Certified Model****Alternate Model Name**

300Mbps Wireless N Gigabit Access Point

EAP120

300Mbps Universal Wi-Fi Range Extender

TL-WA850RE

AC750 Wireless Dual Band 4G LTE Router

Archer MR200

300Mbps Wireless N VDSL/ADSL Modem Router

VN020-F3

AC750 Wireless Dual Band 4G LTE Router

Archer MR200

AC750 Wireless Dual Band Router

C20i

150Mbps Wireless N ADSL2+Modem Router

TD-W8951ND

AC750 Wireless Dual Band Gigabit Router

AC750 Wireless Dual
Band Gigabit Router

Archer C2

N600 Wireless Dual Band Gigabit Access Point

EAP220

300Mbps Wireless N VDSL/ADSL VoIP Modem Router

TP-Link 100v

AC1350 Wireless Dual Band Gigabit Router

EC230-G1

Archer C60, Archer C59, Archer C58

AC1200 Wireless Dual Band Gigabit Router

Archer C1210

AC1750 Wireless Dual Band Gigabit Router

C7

Archer A7, Archer C7, Archer C8

AC1200 Wireless Dual Band Gigabit VoIP VDSL/ADSL
Modem Router

Archer VR500v

AC1200 Wireless Dual Band Gigabit Router

Archer C5

300Mbps Wireless N Access Point

EAP110

AC1900 Wireless Dual Band Gigabit Router

EC330-G5u

Archer C1900

AC1200 Wireless Dual Band Gigabit VoIP VDSL/ADSL
Modem Router

VC221-G3v

300Mbps Wireless N USB VDSL2 Modem Router

TD-W9970

AC1900 Wireless Dual Band Gigabit Router

C9

AC1750 Wireless Dual Band Gigabit Router

C8

Wireless Dual Band 4G LTE Router	Archer MR200	
AC1200 Wireless Dual Band Gigabit VoIP VDSL/ADSL Modem Router	Archer VR1200v	
AC1200 Wireless Dual Band Gigabit Router	Archer C1200	Archer C6
AC1200 Wireless Dual Band Gigabit Router	Archer C5	
AC1900 Touch Screen Wi-Fi Gigabit Router	Touch P5	
AC1200 Whole Home Mesh Wi-Fi System	HC221-G1	
AC900 Wireless Dual Band Router		Archer C25
AC5200 Wireless Tri-Band MU-MIMO Gigabit Router		Archer C5200
AC5400 Wireless Tri-Band MU-MIMO Gigabit Router		Archer C5400
Talon AD7200 Multi-Band Wi-Fi Router		AD7200
AC3000 Wireless Tri-Band Gigabit Router		Archer C3000
AC2600 Wireless Dual Band Gigabit Router		Archer C2600
AC750 Wireless Dual Band Gigabit Router		Archer C2, TL-WR902AC
AX11000 Next-Gen Tri-Band Gaming Router		Archer AX11000
AX6000 Next-Gen Wi-Fi Router		Archer AX6000
AX3000 Dual Band Gigabit Wi-Fi 6 Router		Archer AX50
AX3000 Dual Band Gigabit Wi-Fi 6 Router		Archer AX3000
AX1500 Wi-Fi 6 Router		Archer AX10
AX1500 Wi-Fi 6 Router		Archer AX1500
AC4000 MU-MIMO Tri-Band Wi-Fi Router		Archer C4000, Archer A20
AC2300 Wireless MU-MIMO Gigabit Router		Archer C2300

Patent 7,039,445
Claim 13

Product	WiFi Certified Model	Alternate Model Name
AC1900 Wireless Dual Band Gigabit Router	C9	Archer C1900
AC1750 Wireless Dual Band Gigabit Router	C8	Archer A7, Archer C7, Archer C8
AC1200 Wireless Dual Band Gigabit Router	Archer C5	Archer C1200, Archer C1210, Archer C6
AC1900 Touch Screen Wi-Fi Gigabit Router	Touch P5	
AX11000 Next-Gen Tri-Band Gaming Router		Archer AX11000

AX6000 Next-Gen Wi-Fi Router	Archer AX6000
AX3000 Dual Band Gigabit Wi-Fi 6 Router	Archer AX50
AX3000 Dual Band Gigabit Wi-Fi 6 Router	Archer AX3000
AX1500 Wi-Fi 6 Router	Archer AX10
AX1500 Wi-Fi 6 Router	Archer AX1500
AC4000 MU-MIMO Tri-Band Wi-Fi Router	Archer C4000, Archer A20
AC2300 Wireless MU-MIMO Gigabit Router	Archer C2300

Patent 7,460,477
Claim 7

Product	WiFi Certified Model	Alternate Model Name
AC1350 Wireless Dual Band Gigabit Router	EC230-G1	Archer C60, Archer C59, Archer C58
AC1900 Wireless Dual Band Gigabit Router	EC330-G5u	Archer C9, Archer C1900
AC1900 Touch Screen Wi-Fi Gigabit Router	Touch P5	
AC5200 Wireless Tri-Band MU-MIMO Gigabit Router		Archer C5200
AC5400 Wireless Tri-Band MU-MIMO Gigabit Router		Archer C5400
Talon AD7200 Multi-Band Wi-Fi Router		AD7200
AC1200 Wireless Dual Band Gigabit Router	Archer C1200	
AC3000 Wireless Tri-Band Gigabit Router		Archer C3000
AC2600 Wireless Dual Band Gigabit Router		Archer C2600
AC750 Wireless Dual Band Gigabit Router		Archer C2 (V3)
AC1750 Wireless Dual Band Gigabit Router	C8	Archer A7, Archer C7, Archer C8
AX3000 Dual Band Gigabit Wi-Fi 6 Router		Archer AX50
AX1500 Wi-Fi 6 Router		Archer AX10
AC4000 MU-MIMO Tri-Band Wi-Fi Router		Archer C4000, Archer A20
AC5400 Wireless Tri-Band MU-MIMO Gigabit Router		Archer C5400
AX6000 Next-Gen Wi-Fi Router		Archer AX6000
AX1500 Wi-Fi 6 Router		Archer AX1500
AX3000 Dual Band Gigabit Wi-Fi 6 Router		Archer AX3000

Patent 7,127,210

Claim 20

Product

HA100 - Bluetooth Music Receiver