

**IN THE UNITED STATES DISTRICT COURT
FOR THE WESTERN DISTRICT OF TEXAS
WACO DIVISION**

Health Discovery Corporation

Plaintiff,

v.

Intel Corporation

Defendant.

Civil Action No. 6:20-cv-666

JURY TRIAL DEMANDED

COMPLAINT FOR PATENT INFRINGEMENT

TO THE HONORABLE JUDGE OF SAID COURT:

Plaintiff Health Discovery Corporation (“HDC”), files this Complaint for Patent Infringement and Damages against Defendant Intel Corporation (“Intel” or “Defendant”), and would respectfully show the Court as follows:

PARTIES

1. Plaintiff HDC is a Georgia corporation with its principal place of business at 2002 Summit Blvd., NE, Suite 300, Atlanta, Georgia 30319.
2. On information and belief, Defendant Intel is a Delaware corporation with its principal place of business at 2200 Mission College Boulevard, Santa Clara, California 95054.
3. On information and belief, Intel has multiple places of business within this judicial district, including at least: 1300 S. Mopac Expressway, Austin, TX 78746; 6500 River Place Blvd., Building 7, Austin, TX 78730; and 5113 Southwest Parkway, Austin, TX 78735 (collectively, “Austin Offices”).
<<https://www.intel.com/content/www/us/en/location/usa.html>>. Intel is registered to conduct business in Texas (Texas Taxpayer Number 19416727436), and may be served

through its registered agent, CT Corporation System, 1999 Bryan Street, Suite 900, Dallas, Texas 75201-3136.

A SUMMARY OF THE CONTROVERSY

4. HDC and Intel are not strangers. In fact, the controversy between the parties has been ongoing for nearly a decade. In November 2010, after realizing that Intel had obtained a patent on a learning machine technology (SVM-RFE) that HDC already owned and patented, HDC sought to provoke an interference with Intel's Patent No. 7,685,077 ("Intel's '077 patent"). On October 3, 2011, HDC filed for re-examination of Intel's '077 patent. HDC also later successfully provoked the interference before the Patent Trial and Appeal Board (PTAB) between Intel's '077 patent and HDC's then-pending application directed towards the same SVM-RFE technology. On November 10, 2011, HDC sent a letter to counsel for Intel, advising it of the reexamination and potential interference proceedings, and offering Intel the opportunity to license the HDC patents. In December 2011, counsel for Intel responded to HDC's letter, stating that Intel would likely not fight the patent office proceedings unless Intel was using the SVM-RFE technology. Intel did fight, and thus began a 9-year battle including a three-year interference proceeding during which Intel implemented a scorched-earth strategy, first attempting to claim it was the rightful owner of the SVM-RFE technology at issue, but in the event that failed (which it ultimately did), Intel also tried to invalidate all of the HDC patents-in-suit, as well as sacrifice its own '077 patent in the process, seemingly to continue using the SVM-RFE technology. Ultimately, HDC won the interference proceeding, and Intel's '077 patent was cancelled. During this lengthy exchange with the PTAB, not once did Intel expressly deny using the patented technology. Rather its actions in fighting HDC in the Patent Office for

nearly a decade, and its willingness to invalidate its own patent in exchange for the PTO invalidating the HDC patents, demonstrate that the opposite is true, and that Intel has and continues to use the SVM-RFE technology – a technology patented and owned by HDC. A more detailed timeline of the parties’ interactions and communications is presented in ¶¶ 30-31 *infra*.

5. HDC’s Support Vector Machine-Recursive Feature Elimination (SVM-RFE) is an important technology that is utilized across a broad spectrum of applications (*e.g.*, artificial intelligence, drug discovery, healthcare, economics, coding, data collection and data mining, etc.) and is widely used today. SVM-RFE uses learning machines (*e.g.*, Support Vector Machines-SVM) to identify relevant patterns in datasets, and more specifically, selects features within the datasets that best enable classification of the data (*e.g.*, Recursive Feature Elimination-RFE). As of the date of this complaint, the academic paper that first described HDC’s SVM-RFE technology (discussed in greater detail below) has been cited at least 8,098 times across numerous academic and industry mediums (books, journals, reports, patents, etc.), including at least 378 times in 2020 alone (and counting). Defendant Intel, itself, seems to concede that SVM-RFE is important, as it attempted to patent it for itself – its ‘077 patent – and fought to either keep its ‘077 patent or otherwise destroy all SVM-RFE related patents. As explained below, Intel has itself published numerous technical articles admitting that it has used the SVM-RFE technology in designing and optimizing certain of its microprocessor lines. Given the widespread and continuing use of the SVM-RFE technology by potential customers of Intel, there is no reason to believe Intel has stopped using the technology. In fact, the widespread use of SVM-RFE would require Intel to continue to conduct SVM-RFE testing, validation and

verification tasks, to ensure their processors and Field Programmable Gate Array (FPGA) products can successfully run the SVM-RFE processes required by their customers.

JURISDICTION AND VENUE

6. This is a civil action for patent infringement arising under the Patent Laws of the United States as set forth in 35 U.S.C. §§ 271, *et seq.*
7. This Court has federal subject matter jurisdiction over this action pursuant to 28 U.S.C. §§ 1331 and 1338(a) and pendant jurisdiction over the other claims for relief asserted herein.
8. This Court has personal jurisdiction over Defendant pursuant to TEX. CIV. PRAC. & REM. CODE § 17.041 *et seq.* Personal jurisdiction exists over Defendant because Defendant has minimum contacts with this forum as a result of business regularly conducted within the State of Texas and within this judicial district, and, on information and belief, specifically as a result of, at least, committing the tort of patent infringement within Texas and this judicial district. Personal jurisdiction also exists because, on information and belief, Defendant, *inter alia*:
 - a. has substantial, continuous, and systematic business contacts in this judicial district (for over 20 years – <https://www.intel.com/content/www/us/en/corporate-responsibility/intel-in-texas.html>);
 - b. owns, manages, and operates facilities within this judicial district (*e.g.*, the Austin Offices);
 - c. actively advertises to residents within the judicial district to purchase infringing products;
 - d. actively advertises to residents within the judicial district to work for Intel;

- e. employs residents from the judicial district;
- f. transacts business within the State of Texas;
- g. continues to conduct such business in Texas through the continued operation within the judicial district; and
- h. operates the Internet website, www.intel.com, which is available to and accessed by customers and potential customers of the Defendant within this judicial district.

Accordingly, this Court's jurisdiction over the Defendant comports with the constitutional standards of fair play and substantial justice and arises directly from the Defendant's purposeful minimum contacts with the State of Texas.

9. This Court also has personal jurisdiction over the Defendant as Defendant has purposefully and voluntarily availed itself of the privilege of conducting business in the United States, the State of Texas, and this judicial district (specifically) by continuously and systematically placing goods into the stream of commerce through an established distribution channel with the expectation that such goods will be purchased by consumers within the United States, Texas, and this judicial district. Defendant, either directly and/or through intermediaries, uses, sells, offers to sell, distributes, advertises, and/or otherwise promotes the accused products in this judicial district.

10. On information and belief, Intel has authorized distributors (<https://www.intel.com/content/www/us/en/partner/where-to-buy/overview.html>) within this judicial district that include, *inter alia*:

- a. Arrow Electronics Inc., operates the online store, <https://www.arrow.com/en/manufacturers/intel>, which is available to and accessed by customers and potential customers of the Defendant within this judicial

district, and has an office location within the judicial district at 1908 Kramer Lane, Suite 200, Austin, TX 78758.

- b. Digi-Key Electronics operates the online store, <<https://www.digikey.com/>>, which is available to and accessed by customers and potential customers of the Defendant within this judicial district.
- c. Macnica Americas operates the online store, <<https://www.macnica.com/americas/>>, which is available to and accessed by customers and potential customers of the Defendant within this judicial district.
- d. Mouser Electronics, operates the online store, <<https://www.mouser.com/>>, which is available to and accessed by customers and potential customers of Defendant within this judicial district.

11. On information and belief, Intel partners with at least seventeen (17) virtual appliance and accelerator solutions providers, seven (7) original equipment manufacturer (OEM) server providers, and six (6) system integrators to offer the Intel FPGA Acceleration Hub, <<https://www.intel.com/content/www/us/en/programmable/solutions/acceleration-hub/partners.html>>, which is available to and accessed by customers and potential customers of the Defendant within this judicial district. Several of these Intel partners, *inter alia*, have offices within this judicial district:

- a. Juniper Networks, virtual appliance and accelerator solutions provider, has an office at 1120 S. Capital of Texas Hwy #120, Austin, TX 78746.
- b. Insight Enterprises, a system integrator, has offices located at 11001 Lakeline, Blvd., Building 1, Suite 350, Austin, TX 78717 and 2525 Brockton Dr., Suite 390, Austin, TX 78758.

- c. World Wide Technology, Inc., a system integrator, has offices located at 101 E. Old Settlers Blvd., Round Rock, Texas 78664 and 200 Concord Plaza Dr., Suite 600, San Antonio, TX 78216.
 - d. Dell EMC, an OEM server provider, has multiple offices within this judicial district, including in Austin and San Antonio.
 - e. Hewlett Packard Enterprise, an OEM server provider, has an office located at 14231 Tandem Blvd., Austin, TX 78728.
12. On information and belief, Intel products are sold to and by third parties, such as *inter alia* Best Buy and stores of certain Partners discussed in ¶11, which have multiple locations within this judicial district. Further, one of Intel's top customers, Dell Technologies, Inc., is headquartered in this judicial district at 1 Dell Way, Round Rock, TX 78682.
13. Venue is proper in this Court under 28 U.S.C. §§ 1391(b), (c), (d) and 28 U.S.C. § 1400(b) based on the information and belief that the Defendant has committed or induced acts of infringement, and/or advertise, market, sell, and/or offer to sell products, including infringing products, in this judicial district, as discussed above in ¶¶ 3 and 8-12, which are incorporated by reference herein.
14. On information and belief, Intel has litigated/is litigating cases before this Court, and Intel has admitted the venue was proper and did not contest personal jurisdiction. *See, e.g., FG SRC, LLC v. Intel Corporation*, 6:20-cv-00315-ADA (W.D. Tex.); *ParkerVision, Inc. v. Intel Corporation*, 6:20-cv-00108-ADA (W.D. Tex.); *VLSI Technology LLC v. Intel Corporation*, 1:19-cv-00977-ADA (W.D. Tex.) (Intel unsuccessfully sought transfer for reasons that are absent from the present action, but admitted that if not for those specific

reasons the district's venue and personal jurisdiction would be appropriate. The Court denied the transfer.)

THE PATENTS-IN-SUIT

15. On October 3, 2006, United States Patent No. 7,117,188 (“the ‘188 patent”), entitled “Methods of Identifying Patterns in Biological Systems and Uses Thereof,” was duly and legally issued by the United States Patent and Trademark Office (“USPTO”) to Isabelle Guyon and Jason Weston, with the Health Discovery Corporation (“HDC”) as ultimate assignee. A copy of the ‘188 patent is attached hereto as **Exhibit A**.
16. On June 2, 2009, United States Patent No. 7,542,959 (“the ‘959 patent”), entitled “Feature Selection Method Using Support Vector Machine Classifier,” was duly and legally issued by the USPTO to Stephen Barnhill, Isabelle Guyon and Jason Weston, with the Health Discovery Corporation (“HDC”) as ultimate assignee. A copy of the ‘959 patent is attached hereto as **Exhibit B**.
17. On June 10, 2012, United States Patent No. 8,095,483 (“the ‘483 patent”), entitled “Support Vector Machine – Recursive Feature Elimination (SVM-RFE),” was duly and legally issued by the USPTO to Jason Weston and Isabelle Guyon, with the Health Discovery Corporation (“HDC”) as ultimate assignee. A copy of the ‘483 patent is attached hereto as **Exhibit C**.
18. On September 3, 2019, United States Patent No. 10,402,685 (“the ‘685 patent”), entitled “Recursive Feature Elimination Method Using Support Vector Machines,” was duly and legally issued by the USPTO to Isabelle Guyon and Jason Weston and, with the Health Discovery Corporation (“HDC”) as ultimate assignee. A copy of the ‘685 patent is attached hereto as **Exhibit D**.

19. The '188, '959, '483 and '685 patents are referred to hereinafter as “the HDC Patents.”
20. Plaintiff Health Discovery Corporation is the owner of the entire right, title, and interest in and to the HDC Patents, with the right to sue in its own name.
 - a. Assignment of the '188 patent to HDC was executed between July 28, 2004 and June 1, 2005 and recorded with the USTPO on June 2, 2005.
 - b. Assignment of the '959 patent to HDC was executed between July 28, 2004 and June 1, 2005 and recorded with the USPTO on January 14, 2008.
 - c. Assignment of the '483 patent to HDC was executed between July 28, 2004 and June 1, 2005 and recorded with the USPTO on May 5, 2011.
 - d. Assignment of the '685 patent to HDC was executed between July 28, 2004 and June 1, 2005 and recorded with the USPTO on May 5, 2011.
21. Each of the HDC Patents are presumed valid under 35 U.S.C. § 282.

HDC'S SVM-RFE INVENTORS

22. The inventors of HDC's SVM-RFE patents, Dr. Weston and Dr. Guyon, are world leaders in the field of machine learning. In the late 1980's Dr. Guyon established herself as a leader in the field of artificial intelligence, collaborating at AT&T Bell Labs with renowned mathematicians Vladimir Vapnik and Bernard Boser on the invention of the support vector machine (SVM). Dr. Weston studied under Dr. Vapnik at Bell Labs while working on his PhD, awarded in 2000, where he also began working with Dr. Guyon on leading-edge innovations in machine learning. Today, Dr. Weston and Dr. Guyon are widely recognized as being among the most influential scholars in the field.
23. The first version of the manuscript of the paper that originally disclosed HDC's patented SVM-RFE technology, entitled “Gene Selection for Cancer Classification Using Support

Vector Machines,” with Jason Weston and Isabelle Guyon as co-authors along with Stephen Barnhill and Vladimir Vapnik, was submitted for publication in the journal Machine Learning in 2000. This same manuscript was filed in the United States Patent and Trademark Office on March 22, 2000 as provisional application number 60/191,219, the application having the same title (*hereinafter* referred to as the “Weston paper”). Hong Zhang Declaration, ¶¶ 24 and 25 (**Exhibit E**).

24. In the years following publication of the Weston paper, the CBCL-MIT research group (Center for Biological and Computational Learning at MIT), a major hub of artificial intelligence research and innovation, published several papers on the subject of using support vector machines for cancer classification. In each paper, the CBCL-MIT group credits Weston and Guyon as the source of SVM-RFE technology:

- a. Ramaswamy, et al., in “Multiclass cancer diagnosis using tumor gene expression signatures,” Proceedings of the National Academy of Sciences, 98(26):15149-15143 (2001), describes the use of SVM-RFE for feature selection, citing to the Weston paper. **Exhibit F**.
- b. Rifkin, et al., “An Analytical Method for Multi-class Molecular Cancer Classification,” SIAM Review, 45(4):706-723 (2003), describes the use of SVM-RFE. In the Rifkin paper, the CBCL-MIT research group recognizes and describes the distinctions between conventional linear SVM and SVM-RFE. **Exhibit G**.
- c. Similar discussions and distinctions between conventional SVM and SVM-RFE are offered by Mukherjee in “Classifying Microarray Data Using Support Vector Machines,” Chapter 9 of Understanding and Using Microarray Analysis

Techniques: A Practical Guide, Springer-Verlag, Heidelberg, 2003, pp. 166-185.

Exhibit H.

- d. The CBCL-MIT group included researchers who were luminaries in their field. If they had thought Weston's SVM-RFE was simply an insignificant variation of conventional SVM, they would not have consistently recognized Weston's contribution of the SVM-RFE method. Hong Zhang Declaration, ¶ 29 (**Exhibit E**).
25. Further evidence of the recognition and acceptance that SVM-RFE has achieved in the field is provided by the large number of academic publications that have cited the Weston paper. The Weston paper represented a significant portion of the invention disclosure for the related HDC patents. A search for the Weston paper using Google® Scholar, a web search engine that indexes the full text or metadata of scholarly literature, yields results indicating that from publication in 2002 to 2017, about 5,300 books, academic journals, conference papers, theses, technical reports, patents, and other publications have cited the Weston paper as an authority in the field of SVM and feature selection. Hong Zhang Declaration, ¶ 30 (**Exhibit E**).
26. An updated Google® Scholar search yields that, as of the date of this complaint, the Weston paper has been cited at least 8,098 times, in books, academic journals, conference papers, theses, technical reports, patents, and other publications.

HDC'S SVM-RFE TECHNOLOGY

27. Each of the HDC patents-in-suit relate to innovative technology for using learning machines (*e.g.*, Support Vector Machines) to identify relevant patterns in datasets, and more specifically, to a selection of features within the datasets that best enable classification of the data (*e.g.*, Recursive Feature Elimination).

28. SVMs are mathematical algorithms that allow computers to sift through large, complex datasets to identify patterns. SVMs are known for their ability to discover hidden relationships in these complex datasets. SVMs, with the ability to handle what is known as infinite dimensional space, are broadly considered to be an improvement to neural networks and other mathematical techniques. SVM is a core machine learning technology with strong theoretical foundations and excellent empirical successes. SVMs have become widely established as one of the leading approaches to pattern recognition and machine learning worldwide and have replaced other technologies in a variety of fields, including engineering, information retrieval, and bioinformatics.

29. Support Vector Machine — Recursive Feature Elimination (“SVM-RFE”) is an application of SVM that was invented by Dr. Weston and Dr. Guyon as members of HDC’s science team, to find discriminate relationships within clinical datasets, as well as within gene expression and proteomic datasets created from micro-arrays of tumor versus normal tissues. In general, SVMs identify patterns — for instance, a biomarker/genetic expression signature of a disease. The SVM-RFE utilizes this pattern recognition capability to identify, rank and order the features that contribute most to the desired results, and successively eliminate the features with the lowest rank order, until the optimal feature set is obtained to define the model.

A LONG HISTORY OF INTEL’S USE OF HDC’S SVM-RFE TECHNOLOGY

30. As discussed above, the controversy at hand has been ongoing for nearly a decade. The following is an abbreviated timeline of key events. Paragraph 31 provides additional background and context (bolded entries relate to proceedings in the Patent Office).

DATE	EVENT
November 11, 2010	HDC seeks to provoke interference with Intel's Patent No. 7,685,077.
October 3, 2011	HDC files a request for reexamination of Intel's '077 patent.
November 10, 2011	HDC sends a courtesy letter to Intel advising of the re-examination and potential interference, and attempting to begin communications on a potential collaboration between HDC and Intel.
December 2011	An Intel Senior Patent Attorney states that he is looking into the matter for Intel and that Intel would likely not fight the re-examination if it is not using the SVM-RFE technology.
February 21, 2012	Intel Senior Patent Attorney writes that he is unaware of infringing activity.
March 15, 2012	HDC's response to the February 21, 2012 letter provides copies of publications by Intel researchers describing Intel's use of SVM-RFE, Northwestern University's acknowledgement of Intel's contribution of and to the SVM-RFE package, and commenting on Intel's filing of a response to rejection of all claims in the '077 re-examination; HDC invites further negotiation for a license.
September 19, 2016	A Declaration of Interference is filed with the PTAB, naming HDC as the Senior Party and Intel as the Junior Party.
September 26, 2016	HDC's Chairman sends another courtesy letter to Intel, this time regarding the Declaration of Interference and again offering a mutually beneficial collaboration between the two parties.
September 30, 2016	Intel emails HDC asking what HDC needs to resolve this interference. HDC responds that Intel needs to license SVM-RFE from HDC and disclaim its '077 patent.

October 3, 2016	HDC discusses the possibility of Intel licensing SVM-RFE from HDC with Intel's outside counsel.
November 2016	Counsel for HDC and Counsel for Intel exchange emails in which Intel stated it does not need a license, the HDC patents are invalid, and Intel does not infringe.
January 23, 2017	Intel concedes to the PTAB that HDC has priority over the invention, and files two separate motions attempting to invalidate all the patents-in-suit, and Intel's own '077 patent if necessary.
April 19, 2017	Counsel for Intel states that Intel is unlikely to settle.
May 1, 2017	HDC's Chairman sends another letter to Intel, this time to Intel's President, offering a mutually beneficial collaboration. Intel did not respond.
February 27, 2019	HDC wins the interference.
March 26, 2019	HDC's Chairman sends another email to Intel's President offering a mutually beneficial collaboration. Again, Intel did not respond.
September 3, 2019	The USPTO issues U.S. Patent No. 10,402,685 ("SVM-RFE Patent") (one of the Patents-in-Suit) for HDC's patent application that provoked the interference.

31. The following provides additional background and context for the abbreviated timeline presented in Paragraph 30:

- a. On November 11, 2010, HDC filed patent application 12/944,197 in an effort to provoke an interference with Intel's Patent No. 7,685,077 ("Intel's '077 patent").¹ HDC's application directly copied the claims of Intel's '077 patent to provoke the interference. Nearly nine years later, HDC's application was granted as U.S. Patent No. 10,402,685 (one of the patents-in-suit).
- b. On October 3, 2011 HDC filed an *Ex parte* reexamination request on Intel's '077 patent.
- c. On November 10, 2011, HDC sent a letter to Intel's Steven Rodgers (*see infra* ¶ 49 for more information) advising Intel that HDC had sought re-examination of Intel's '077 patent, and was also seeking to initiate an interference proceeding regarding Intel's '077 patent. In the November 10, 2011 letter:
 - i. HDC explained that Dr. Isabelle Guyon, an HDC inventor, was both an original inventor of the SVM technology (*see, e.g.*, U.S. Patent No. 5,649,068) and an original inventor of the SVM-RFE technology (*see, e.g.*, Guyon, et al. "Gene Selection for Cancer Classification Using Support Vector Machines," *Machine Learning* (2002)). Guyon's 2002 paper serves as the basis for HDC's U.S. Patent No. 7,177,188 and No. 7,542,959 (both patents-in-suit), two additional pending U.S. applications (both granted as the remaining patents-in-suit), and additional foreign patents.

¹ Intel's '077 patent is entitled "Recursive Feature Eliminating Method based on a Support Vector Machine," which directly echoes HDC's patented Support Vector Machine-Recursive Feature Elimination technology. HDC sought to provoke the interference to determine which party was the first to invent an invention that was claimed in two (or more) independently owned patent applications.

- ii. HDC attempted to discuss a mutually beneficial collaboration with Intel, whereby Intel could obtain proper authorization to use HDC's patented SVM-RFE technology (and possibly other HDC technologies) by license, and both parties could avoid unnecessary and costly legal proceedings.
- d. On November 21, 2011, HDC received a letter from an Intel Senior Patent Attorney advising that he would be handling the matter.
- e. In December 2011, HDC's counsel and Intel's Senior Patent Attorney had a telephone conference in which Intel's attorney stated he would look into the matter and that Intel probably would not fight if Intel was not using the technology. In fact, Intel continued to fight the PTO proceedings for another eight years.
- f. On February 21, 2012, HDC received a letter from Intel's Senior Patent Attorney asking for specific Intel products to be identified.
- g. On March 15, 2012, HDC sent a letter to Intel identifying Intel publications and presentations describing Intel's admitted use of the SVM-RFE technology.
- h. On September 19, 2016 the Declaration of Interference was filed before the Patent Trial and Appeal Board (PTAB), naming HDC as the Senior Party and Intel as the Junior Party.
- i. On September 26, 2016, HDC's Chairman sent a letter to an Intel Senior Patent Attorney regarding the Declaration of Interference and again offering to collaborate with Intel, to benefit both parties. In this letter, HDC shared its future goals for SVM-RFE and machine learning, hoping to find common ground with Intel.
- j. On September 30, 2016, HDC received an email from Intel's Patent Group Counsel asking what HDC wanted in order to resolve the interference. HDC responded

requesting that Intel licenses SVM-RFE from HDC and disclaims Intel's '077 patent.

- k. On October 3, 2016, HDC had a telephone conference with outside counsel for Intel regarding the possibility of a license and followed up via email regarding the same.
- l. On November 3-4, 2016, emails exchanged between HDC and Intel's outside counsel stated, for the first time, that Intel (wrongly) believed that HDC's patents were invalid and Intel did not infringe.
- m. On January 23, 2017, Intel conceded that HDC has priority over the invention – as Intel's alleged priority date of July 20, 2006 was after HDC's accorded priority date of January 31, 2005. *See* Interference Doc. 23.
- n. After conceding priority, however, on the same day, January 23, 2017, Intel filed a motion in the Interference arguing that all the claims of HDC's 12/944,197 application (which were directly copied from Intel's '077 patent) were unpatentable as being directed to patent-ineligible subject matter. *See* Interference Doc. 21.
- o. On the same day, January 23, 2017, Intel filed another motion in the Interference arguing that HDC's Patent Nos. 7,117,188, 7,542,959, and 8,095,483 (all patents-in-suit) were also unpatentable as being directed to patent-ineligible subject matter. *See* Interference Doc. 20.
- p. On April 19, 2017, Intel's outside counsel stated that Intel was unlikely to settle.
- q. On May 1, 2017, HDC's Chairman sent Intel's President a letter again offering a mutually beneficial collaboration. Intel's President did not respond.
- r. On February 27, 2019, the PTAB filed a judgement on the interference in favor of HDC and cancelled Intel's '077 patent.

- s. On March 26, 2019, HDC's Chairman again emailed Intel's President offering a mutually beneficial collaboration. Again, Intel's President did not respond.
 - t. On September 3, 2019, the USPTO issued U.S. Patent No. 10,402,685 ("SVM-RFE Patent") (one of the Patents-in-Suit) for HDC's patent application covering SVM-RFE methods. Health Discovery Corporation now owns four patents in the United States and five international patents related to SVM-RFE and is the sole owner of all patents related to SVM-RFE.
32. On information and belief, Defendant Intel would not have so rigorously, and at great expense of time and resources, defended Intel's '077 patent unless it was actually using and benefiting from SVM-RFE.
33. On information and belief, Intel's admission in December 2011 that it would not fight the re-examination of its '077 patent unless it was actually using the SVM-RFE technology indicates that Intel is using the technology, as it did fight both the re-examination and the interference.
34. In this near decade long controversy, Intel has never explicitly denied using SVM-RFE technology. Rather, on information and belief, Intel's actions (*e.g.*, fighting the re-examination; fighting the interference; attempting to patent SVM-RFE technology for itself; remaining silent on whether it is or is not using SVM-RFE; attempting to invalidate all patents related to SVM-RFE), is evidence of, or at least strongly suggestive, that Intel is in fact using HDC's SVM-RFE technology.
35. Further, Intel has admitted (many times) in numerous publications and presentations to using SVM-RFE in the development and optimization of certain of Intel's products. On information and belief, Intel has used the SVM-RFE method as a tool in developing,

testing, validating, verifying and optimizing certain of Intel's products (software, hardware, packages, etc.). The publications and presentations by Intel researchers describing Intel's unauthorized use of SVM-RFE date back at least as far as May 2005. A non-exhaustive list of such publications/presentations includes, *inter alia*:

- a. Yurong Chen, et al., "Performance Scalability of Data-Mining Workloads in Bioinformatics," *Intel Technology Journal*, Vol. 9, Issue 2, May 19, 2005. **Exhibit I.**
- b. Uma Srinivasan, et al., "Characterization and Analysis of HMMER and SVM-RFE," *Proceedings of the IEEE International Symposium on Workload Characterization (IISWC)*, Oct. 2005. **Exhibit J.**
- c. Joseph Zambreno, et al., "Performance Characterization of Data Mining Applications using MineBench," *Proceedings of the Workshop on Computer Architecture Evaluation using Commercial Workloads (CAECW)*, February 2006. **Exhibit K.**
- d. Jayaprakash Pisharath, "Accelerating Data Mining Workloads: Current Approaches and Future Challenges in System Architecture Design," *Proceedings of the International Workshop on High Performance Data Mining (HPDM)*, April 2006. **Exhibit L.**
- e. Ramanathan Narayanan, "MineBench: A Benchmark Suite for Data Mining Workloads," *Proceedings of the International Symposium on Workload Characterization (IISWC)*, October 2006. **Exhibit M.**
- f. Aamer Jaleel, et al., "Last Level Cache (LLC) Performance of Data Mining Workloads on a CMP- A Case Study of Parallel Bioinformatics Workloads,"

Proceedings of the 12th IEEE International Symposium on High Performance Computer Architecture (HPCA), 2006. **Exhibit N.**

- g. A. Choudhary, et al., "Optimizing Data Mining Workloads using Hardware Accelerators," *Proceedings of the Workshop on Computer Architecture Evaluation using Commercial Workloads (CAECW)*, February 2007. **Exhibit O.**
- h. Wenlong Li, et al., "Understanding the Memory Performance of Data-Mining Workloads on Small, Medium, and Large-Scale CMPs Using Hardware-Software Co-simulation," *Proceedings of the IEEE International Symposium on Performance Analysis of Systems & Software (ISPASS)*, April 2007. **Exhibit P.**
- i. Youfeng Wu, et al., "Impacts of Multiprocessor Configurations on Workloads in Bioinformatics," *Proceedings of the 19th International Symposium on Computer Architecture and High-Performance Computing (SBAC-PAD '07)*, October 2007. **Exhibit Q.**
- j. Jiaqi Zhang, et al., "Exploring the Emerging Applications for Transactional Memory," *Proceedings of the IEEE Ninth International Conference on Parallel and Distributed Computing, Applications and Technologies (PDCAT 2008)*, December 2008. **Exhibit R.**
- k. U.S. Patent Publication No. US 2010/0315337 A1 and WIPO Publication No. WO2010/147704, Ferren et al., "Optical Capacitive Thumb Control with Pressure Sensor."
- l. U.S. Patent No. 8,347,301 B2, Wenlong Li, et al., "Device, System, and Method of Scheduling Tasks of a Multithreaded Application." (This Intel patent issued January 1, 2013 and describes the use of SVM-RFE at least at 3:43-44, 7:25 and 7:48-52).

36. On information and belief, Intel's January 23, 2017 motions before the PTO in connection with the Interference proceeding (*supra* ¶ 31(n-o)) were Intel's "scorched-earth" effort at mutual destruction. By arguing that all the claims of HDC's 12/944,197 application were unpatentable, Intel was effectively trying to destroy its own patent (the '077 patent), which HDC had directly copied to provoke the interference. On information and belief, Intel's attempt to destroy both HDC's pending application (and thus Intel's own patent) and HDC's SVM-RFE related patents, was either extremely spiteful or otherwise indicative that Intel is using the SVM-RFE invention (such that Intel tried to destroy all the patents so that it could continue to use the SVM-RFE invention). On further information and belief, this action by Intel indicates clear intent and motivation for Intel's continued use.
37. On information and belief, Defendant Intel has reaped significant benefit, and continues to do so, by exploiting HDC's patented invention to develop, improve, and optimize Intel products, and embed SVM-RFE capabilities in its products. Further, such exploitation has also added value to Intel's commercial offerings.
38. On information and belief, Intel's increased interest in health and life science applications (*e.g.*, healthcare big data, personalized medicine, etc.) suggests Intel's continued and probable use of SVM-RFE technology.

COUNT I
INFRINGEMENT OF THE '188 PATENT

39. Plaintiff HDC repeats and realleges the above paragraphs, which are incorporated by reference as if fully restated herein.
40. Plaintiff HDC is the owner by assignment of all right, title, and interest in the '188 patent, including all right to recover for any and all infringement thereof.
41. Defendant is not licensed or otherwise authorized to practice the '188 patent.

42. The '188 patent is valid and enforceable. In this regard, the '188 patent is presumed valid under 35 U.S.C. §282.
43. The '188 patent relates to, among other things, methods for using learning machines (*e.g.*, Support Vector Machines) to identify relevant patterns in datasets and select relevant features within the datasets to optimize data classification (*e.g.*, using Recursive Feature Elimination). The '188 patent invented such methods, for example, to identify patterns in biological systems (*e.g.*, genes, gene products, proteins, lipids, and combinations of the same) to help, *e.g.*, diagnose and predict abnormal physiological states.
44. On information and belief, Defendant manufactures and markets infringing products, and uses software that infringes HDC's method and apparatus claims. *See*, ¶¶ 52-54, *infra*. Such products infringe on the inventive aspects of the '188 patent and include, *inter alia*, Intel processors (*e.g.*, Intel Xeon series; etc.), Intel Field Programmable Gate Arrays (FPGAs) and System on Chips (SoCs) (*e.g.*, Intel Agilex Series; Intel Stratix Series; etc.), and Intel software (*e.g.*, Intel Data Analytics Acceleration Library). Intel processors, FPGAs, SoCs, and software are deployed, for example, in Intel/Intel-partnered computers, workstations, network-computer architectures, and cloud-based architectures. On information and belief, Intel uses machine learning software programs in-house to test, validate, verify and optimize their processors and conduct comparative studies, and these machine learning software programs employ SVM-RFE methods claimed in HDC's patents.
45. The '188 patent is well-known in the SVM-RFE industry. It has been cited in at least 77 U.S. patents and patent applications, including patents and patent applications filed by

industry leaders, such as Google Inc., Microsoft Corporation, General Electric Company, and Siemens Ag.

46. On information and belief, Defendant has been aware of the '188 patent since at least May 15, 2008. According to the records of the U.S. Patent and Trademark Office, on or about May 15, 2008, Defendant Intel cited the '188 patent to the U.S. Patent and Trademark Office in connection with the prosecution of U.S. Patent Application 12/152,568, entitled "Forward Feature Selection For Support Vector Machines." Specifically, Intel filed an "Information Disclosure Statement by Applicant" listing the '188 patent as the only document, thus demonstrating Defendant's knowledge of the '188 patent.
47. In addition, the '188 patent was cited in at least the following Intel patent, which further demonstrates Defendant's knowledge of the '188 patent: US 8,756,174 entitled "Forward Feature Selection For Support Vector Machines," a continuation of U.S. Patent Application 12/152,568 cited in ¶ 46 *supra*. Specifically, on October 7, 2013, Intel filed an "Information Disclosure Statement by Applicant" listing the '188 patent, thus demonstrating Defendant's knowledge of the '188 patent.
48. The '188 patent was cited in at least one Intel Corporation patents via family-to-family citations, including:
 - a. WO Patent No. 2007016814, "A Recursive Feature Eliminating Method Based on a Support Vector Machine," with a publication date of February 15, 2007. Notably, this World Intellectual Property Organization patent is the same as Intel's '077 Patent.
49. Moreover, Plaintiff HDC began corresponding with Defendant about the SVM-RFE patents, including the '188 patent, in November 2011. Specifically, HDC sent a letter to

Steven Rodgers on November 10, 2011, advising of a reexamination of Intel Patent No. 7,685,077, and a filing to provoke an interference with the '077 patent. On information and belief, Steven Rodgers was Intel's Vice President of Legal and Corporate Affairs in November 2011. At the time of this filing, Rodgers is now Executive Vice President and General Counsel for Intel.

50. Therefore, Defendant had actual and constructive knowledge of the '188 patent, as well as actual and constructive knowledge of the relevance and significance of the '188 patent to its research and development, as well as its product offerings, at least no later than May 15, 2008 (per Intel's IDS solely citing the '188 patent), and certainly no later than November 10, 2011 (per HDC direct correspondence).

Defendant's Direct Infringement of the '188 Patent

51. On information and belief, in violation of 35 U.S.C. § 271(a), Defendant has directly infringed, continues to directly infringe, and will continue to directly infringe, absent the Court's intervention, one or more claims of the '188 patent, including for example (but not limited to) at least computer-implemented method claims 1-12, 13-18, and 19-23 of the '188 patent, either literally or under the doctrine of equivalents, by making, using, testing, selling, and/or offering to sell within the United States, or importing into the United States, without license or authority, Defendant's infringing products, including, but not limited to, at least Intel AI-optimizing/machine learning processors, FPGAs, SoCs, and/or software – which are, *inter alia*, deployed in Intel/Intel-partnered computers, workstations, network-computer architectures, and cloud-based architectures. Defendant's infringing products also include software applications or libraries that incorporate SVM-RFE algorithms, such as Intel's Data Analytics Acceleration Library

(DAAL) that utilizes SVM-RFE algorithms contained in the scikit-learn open source software. The following products and software are representative, *see* paragraphs 52-54 *infra*, of Intel's infringement.

52. **Representative Intel Processors:**

Intel's Xeon Family

According to Intel, the **Intel® Xeon® Processor Family** is the processor brand of Intel® geared towards mission-critical businesses and for big data insights, the brand including Intel® Xeon® D Processors (optimized for density and lower power), Intel® Xeon® W Processors (optimized for mainstream workstations), and Intel® Xeon® E Processors (offer essential performance for entry servers and entry workstations).





Source: <https://www.intel.com/content/www/us/en/products/processors/xeon.html> (last accessed July 1, 2020)



Source: <https://www.intel.com/content/www/us/en/benchmarks/intel-data-center-performance.html> (last accessed July 1, 2020)

	
<p>Scalable Performance</p> <p>Intel® Xeon® Scalable processors are designed for the performance demands of complex, data-demanding workloads such as in-memory databases, and real-time business analytics.</p> <p>Learn more about Intel® Xeon® Scalable processors ></p>	<p>Big Data Analytics</p> <p>To realize the full potential of big data, organizations must find a new approach to capturing, storing, and analyzing data. Our infrastructure technologies are specifically designed for data-intensive, enterprise environments.</p> <p>Learn about Intel® big data technologies using Apache Hadoop® software ></p>

Source: <https://www.intel.com/content/www/us/en/benchmarks/intel-data-center-performance.html> (last accessed July 1, 2020)

	
<p>Density</p> <p>As an emerging server form factor, microservers are designed to process workloads for hyper-scale data centers. Employ microservers to eliminate the space and power consumption of duplicate infrastructure components.</p> <p>Find out about high-density processors ></p>	<p>Enabled Software</p> <p>Optimized independent software vendor (ISV) applications for Intel® Xeon® E5-2600 v4 processor product family—increasing the speed and performance of vital applications.</p> <p>More on enabled technical computing software ></p>

Source: <https://www.intel.com/content/www/us/en/benchmarks/intel-data-center-performance.html> (last accessed July 1, 2020)

<p>High Performance Computing</p> <p>Designed to help solve your biggest challenges faster and with greater efficiency, the Intel® Xeon Phi™ processor enables machines to rapidly learn without being explicitly programmed, in addition to helping drive new breakthroughs using high performance modeling and simulation, visualization and data analytics.</p> <p>More on high performance computing ></p>

Source: <https://www.intel.com/content/www/us/en/benchmarks/intel-data-center-performance.html> (last accessed July 1, 2020)

53. Representative Field Programmable Gate Arrays (FPGAs):

Intel's Stratix Family (e.g., Intel Stratix 10 NX FPGAs)

According to Intel, the *Intel® Stratix® 10 NX FPGA* is an AI-optimized FPGA of Intel® for AI acceleration applications that require high-bandwidth and low-latency memory bandwidth. It can be used for, *inter alia*, natural language processing, security, genomics, and real time video analytics.



Intel® Stratix® 10 NX FPGA is an AI-optimized FPGA for high-bandwidth, low-latency artificial intelligence (AI) acceleration applications. The Intel® Stratix® 10 NX FPGA delivers accelerated AI compute solution through AI-optimized compute blocks with up to 15X more INT8¹ throughput than standard Intel® Stratix® 10 FPGA DSP Block; in package 3D stacked HBM high-bandwidth DRAM; and up to 57.8G PAM4 transceivers.

Source: <https://www.intel.com/content/www/us/en/products/programmable/fpga/stratix-10/nx.html> (last accessed July 1, 2020)

Up to 15X More INT8¹ Throughput for AI Applications

The Intel® Stratix® 10 NX FPGA embed a new type of AI-optimized block called the AI Tensor Block. The AI Tensor Block is tuned for the common matrix-matrix or vector-matrix multiplications used in AI computations, with capabilities designed to work efficiently for both small and large matrix sizes. A single AI Tensor Block achieves up to 15X more INT8¹ throughput than standard Intel® Stratix® 10 FPGA DSP Block.

High Low-Latency Memory Bandwidth for Memory Bound Solution

The integrated memory stacks allow for large, persistent AI models to be stored on-chip, which results in lower latency with large memory bandwidth to prevent memory-bound performance challenges in large models.

Source: <https://www.intel.com/content/www/us/en/products/programmable/fpga/stratix-10/nx.html> (last accessed July 1, 2020)

Scalable and Flexible I/O Connectivity Bandwidth

Intel® Stratix® 10 NX FPGA include up to 57.8 Gbps PAM4 transceivers to implement multi-node AI inference solutions, reducing or eliminating bandwidth connectivity as a limiting factor in multi-node designs. The Intel® Stratix® 10 NX FPGA also incorporates hard IP such as PCIe Gen3 x16 and 10/25/100G Ethernet MAC/PCS/FEC. These transceivers provide a scalable connectivity solution and the flexibility to adapt to market requirements.

Source: <https://www.intel.com/content/www/us/en/products/programmable/fpga/stratix-10/nx.html> (last accessed July 1, 2020)

AI Tensor Block

Using Intel® Stratix® 10 NX FPGA, AI acceleration designs can achieve up to 15X more INT8² throughput than standard Intel® Stratix® 10 FPGA DSP Block. This computational throughput is made possible by a new type of AI-optimized computation block called the AI Tensor Block. The AI Tensor Block contains dense arrays of lower-precision multipliers typically used in AI applications. The AI Tensor Block's architecture is tuned for common matrix-matrix or vector-matrix multiplications used in a wide range of AI computations, with capabilities designed to work efficiently for both small and large matrix sizes.

Intel® Stratix® 10 NX FPGA AI Tensor Block

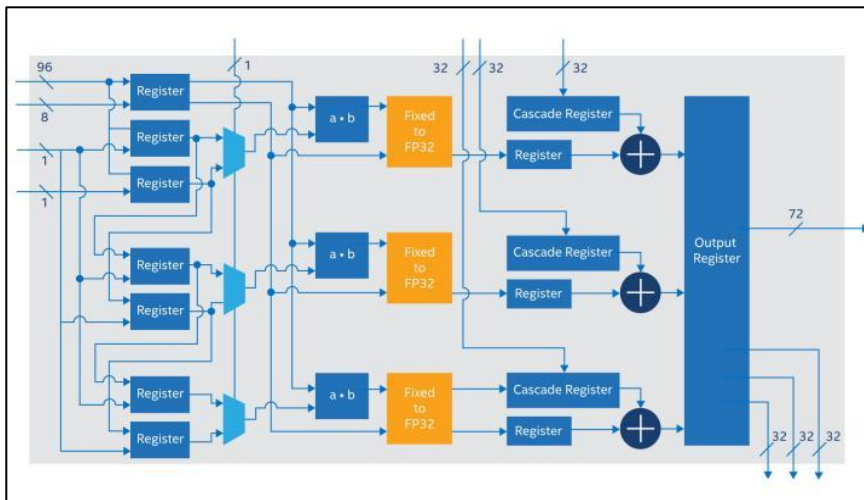

The AI Tensor Block multipliers have base precisions of INT8 and INT4 and support FP16 and FP12 numerical formats through shared-exponent support hardware. All additions or accumulations can be performed with INT32 or IEEE754 single-precision floating point (FP32) precision and multiple AI Tensor Block can be cascaded together to support larger matrices.

Source: <https://www.intel.com/content/www/us/en/products/programmable/fpga/stratix-10/features.html> (last accessed July 1, 2020)

Intel's Agilex Family (e.g., Agilex F-Series FPGAs and SoCs)

According to Intel, the *Intel® Agilex™ F-Series FPGAs & SoCs* are FPGAs and SoCs of Intel® that provide agility and flexibility across diverse markets for a wide range of applications in Data Center, Networking, and Edge, providing the customized connectivity and acceleration needed for power sensitive application.



Built on Intel's 10nm process node and 2nd Gen Intel® Hyperflex™ FPGA Architecture, Intel® Agilex™ F-Series FPGAs and SoC FPGAs are optimized for a wide range of applications in Data Center, Networking, and Edge. With transceiver support up to 58Gbps, advanced DSP capabilities, high system integration through Intel's EMIB technology, and options to include quad-core Arm® Cortex- A53 processor Intel® Agilex™ F-Series FPGAs and SoC FPGAs provide customized connectivity and acceleration required by power sensitive applications.

Source: <https://www.intel.com/content/www/us/en/products/programmable/fpga/agilex/f-series.html> (last accessed July 1, 2020)

3D System-in-Package Technology

Intel® Agilex™ F-Series FPGA and SoC FPGA family leverages Intel® EMIB (Embedded multi-die interconnect bridge) technology to deliver configurable heterogeneous architectures in a single package and to accelerate time-to-market for a variety of solutions. Dedicated transceiver tiles which provide up to 58Gbps bandwidth, the ability to integrate custom compute, and Intel® eASIC™ tiles combine to deliver a high degree of agility and flexibility to customize and adapt designs to the changing needs of a host of applications.

DSP Block Innovation

Intel® Agilex™ F-Series FPGA and SoC FPGA family offers up to 2X the number of configurable multipliers per DSP block compared to previous generation products and are highly suitable for Video, Vision analytics, and Radar applications. New innovations to aid AI workloads include half-precision floating point implementation (FP16) and BFLOAT 16 implementation. Intel® Agilex™ FPGA and SoC family also supports low precision configurations from INT7 to INT2 for systems targeting high performance.

Source: <https://www.intel.com/content/www/us/en/products/programmable/fpga/agilex/f-series.html> (last accessed July 1, 2020)

2nd Gen Intel® Hyperflex™ Architecture

Continuous improvements to the acclaimed Intel® Hyperflex™ architecture deliver improved performance compared to Intel® Stratix® 10 device designs. The 2nd Gen Intel® Hyperflex™ architecture will be extended to all densities and variants of Intel® Agilex™ FPGA and SoC family and thus greatly improve the productivity of customers and reduce time-to-market.

Hard Processor System Architecture

Intel® Agilex™ F-Series FPGA and SoC FPGA family provides the option to combine a quad-core Arm® Cortex-A53 hard processor system with Intel's 2nd Gen Intel® Hyperflex™ FPGA Architecture to deliver high power efficiency and system integration. Backward compatibility with previous generation Intel® Stratix® 10 SoCs allows software re-use. A broad ecosystem of Arm® software and tools greatly improves productivity for designers.

Source: <https://www.intel.com/content/www/us/en/products/programmable/fpga/agilex/f-series.html> (last accessed July 1, 2020)

Intel's Programmable Acceleration Card with Intel Arria

According to Intel, this *PCI Express* (PCIe*)-based FPGA accelerator card* for data centers provides the performance and versatility of FPGA acceleration and is one of several platforms supported by the Acceleration Stack for Intel® Xeon® CPU with FPGAs. Along with acceleration libraries and development tools, the acceleration stack

saves developers time and enables code re-use across multiple Intel FPGA platforms. The Intel Programmable Acceleration Card with Intel Arria® 10 GX FPGA can be implemented in many market segments, such as big data analytics, artificial intelligence, genomics, video transcoding, cybersecurity, and financial trading.

Source: https://www.intel.com/content/www/us/en/programmable/products/boards_and_kits/dev-kits/altera/acceleration-card-arria-10-gx/overview.html (last accessed July 1, 2020)

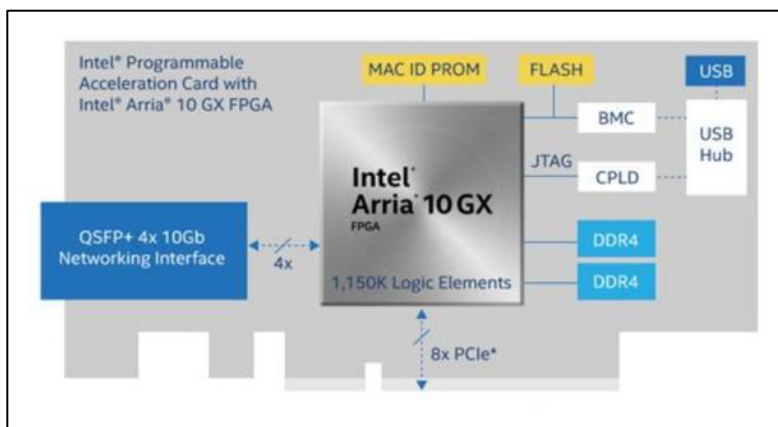

Source: https://www.intel.com/content/www/us/en/programmable/products/boards_and_kits/dev-kits/altera/acceleration-card-arria-10-gx/overview.html (last accessed July 1, 2020)

54. Representative Software Used by Intel:

Intel Using Scikit-learn with Intel’s Data Analytics Acceleration Library (DAAL).

Intel® Data Analytics Acceleration Library (Intel® DAAL): according to Intel, this is the library of Intel® Architecture optimized building blocks covering all data analytics stages: data acquisition from a data source, preprocessing, transformation, data mining, modeling, validation, and decision making.

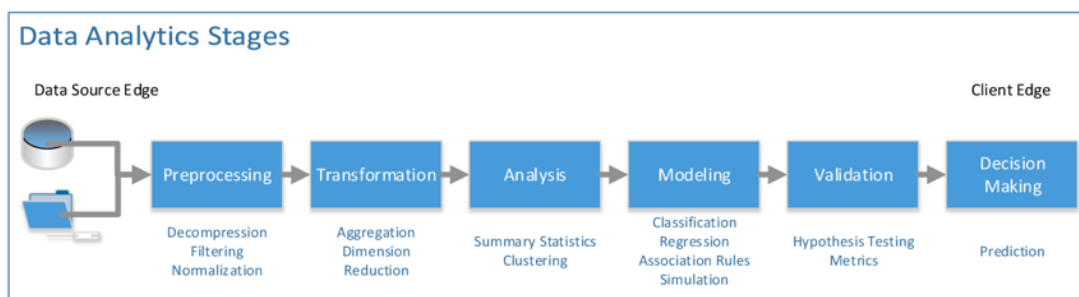

Source: Intel Data Analytics Acceleration Library 2020 Update 1 – Developer Guide, p. 9

Intel DAAL is closely integrated with and leverages the capabilities of the Scikit-learn machine language. In fact, Intel admits that its AI Analytics Toolkit includes Scikit-learn:

“Using this toolkit, you can:

- Deliver high-performance deep learning (DL) training on CPUs and integrate fast inference into your AI applications with Intel-optimized DL frameworks: TensorFlow* and PyTorch*.
- Achieve drop-in acceleration for data analytics and machine learning workflows with compute-intensive Python* packages – Pandas, NumPy, SciPy, **Scikit-learn***, and XGboost*.”

Source: https://software.intel.com/content/www/us/en/develop/tools/oneapi/ai-analytics-toolkit.html?cid=sem&source=sa360&campid=2020_q2_iags_us_iagsoapi_iagsoapiee_awa_text-link_brand_bmm_cd_dpd-oneapi-analytic-toolkit_O-20WWS_google_div_oos_non-pbm&ad_group=brand_oneapi-ai-toolkit_awa&intel_term=%2Bintel+%2Bscikit-learn&sa360id=43700053515352496&&gclid=EAIAIQobChMI3ry37PzZ6gIVCLLICh28rAhFEAAYASAAEgLGQfD_BwE (last accessed July 17, 2020) (emphasis added)

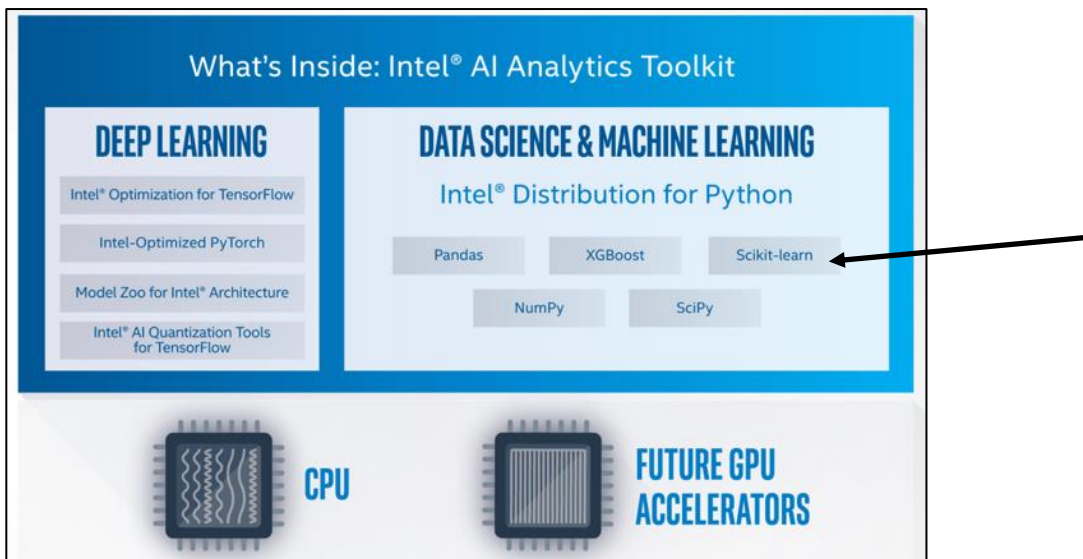

Source: https://software.intel.com/content/www/us/en/develop/tools/oneapi/ai-analytics-toolkit.html?cid=sem&source=sa360&campid=2020_q2_iags_us_iagsoapi_iagsoapiee_awa_text-link_brand_bmm_cd_dpd-oneapi-analytic-toolkit_O-20WWS_google_div_oos_non-pbm&ad_group=brand_oneapi-ai-toolkit_awa&intel_term=%2Bintel+%2Bscikit-learn&sa360id=43700053515352496&&gclid=EAIAIQobChMI3ry37PzZ6gIVCLLICh28rAhFEAAYASAAEgLGQfD_BwE (last accessed July 17, 2020) (emphasis added)

Scikit-Learn Machine Language: Scikit-learn is an open source software machine learning library for the Python programming language. Scikit-learn comprises various classification, regression and clustering algorithms including support vector machines

(SVMs), random forests and gradient boosting, and is designed to interoperate with the Python numerical and scientific libraries NumPy and SciPy. Importantly, Scikit-learn uses feature ranking with recursive feature elimination (RFE) for feature selection as shown below:

```
class sklearn.feature_selection.RFE(estimator, *, n_features_to_select=None, step=1, verbose=0)
```

Source: https://scikit-learn.org/stable/modules/generated/sklearn.feature_selection.RFE.html (last accessed July 7, 2020)

As described on the Scikit-learn website:

Given an external estimator that assigns weights to features (*e.g.*, the coefficients of a linear model), the **goal of recursive feature elimination (RFE) is to select features by recursively considering smaller and smaller sets of features**. First, the estimator is trained on the initial set of features and the importance of each feature is obtained either through a `coef_` attribute or through a `feature_importances_` attribute. Then, **the least important features are pruned from current set of features. That procedure is recursively repeated on the pruned set until the desired number of features to select is eventually reached.**

Source: https://scikit-learn.org/stable/modules/generated/sklearn.feature_selection.RFE.html (last accessed July 7, 2020) (emphasis added)

The Recursive Feature Elimination (RFE) ranking function is further described with reference to graphical data on the Scikit-learn website as follows:

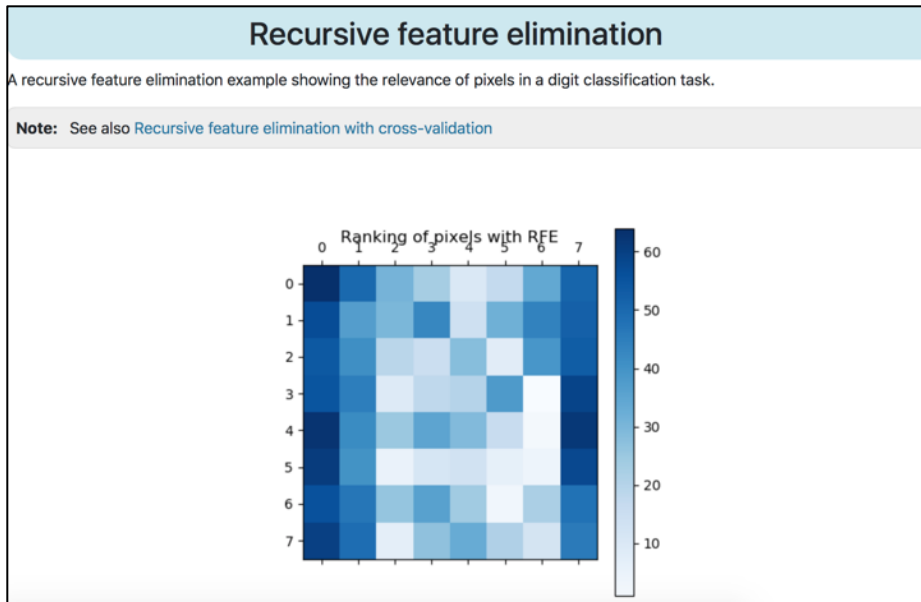

Source: https://scikit-learn.org/stable/auto_examples/feature_selection/plot_rfe_digits.html#sphx-glr-auto-examples-feature-selection-plot-rfe-digits-py (last accessed July 7, 2020)

Note in the sample code below, the SVM classifier is initially imported, then the RFE function is imported for feature selection, with the ranking based on a linear kernel:

```
print(__doc__)

from sklearn.svm import SVC
from sklearn.datasets import load_digits
from sklearn.feature_selection import RFE
import matplotlib.pyplot as plt

# Load the digits dataset
digits = load_digits()
X = digits.images.reshape((len(digits.images), -1))
y = digits.target

# Create the RFE object and rank each pixel
svc = SVC(kernel="linear", C=1)
rfe = RFE(estimator=svc, n_features_to_select=1, step=1)
rfe.fit(X, y)
ranking = rfe.ranking_.reshape(digits.images[0].shape)

# Plot pixel ranking
plt.matshow(ranking, cmap=plt.cm.Blues)
plt.colorbar()
plt.title("Ranking of pixels with RFE")
plt.show()
```

Source: https://scikit-learn.org/stable/auto_examples/feature_selection/plot_rfe_digits.html#sphx-glr-auto-examples-feature-selection-plot-rfe-digits-py (last accessed July 7, 2020)

Another example of the integrated nature of scikit-learn and Intel DAAL is set forth below, highlighting the API compatibility between the two software programs, including Support Vector Machine (SVM) algorithms:

scikit-learn API

The `daal4py.sklearn` package contains scikit-learn compatible API which implement a subset of scikit-learn algorithms using Intel® DAAL.

Currently, these include:

1. `daal4py.sklearn.neighbors.KNeighborsClassifier`
2. `daal4py.sklearn.ensemble.RandomForestClassifier`
3. `daal4py.sklearn.ensemble.RandomForestRegressor`
4. `daal4py.sklearn.cluster.KMeans`
5. `daal4py.sklearn.decomposition.PCA`
6. `daal4py.sklearn.linear_model.Ridge`
7. `daal4py.sklearn.svm.SVC`
8. `daal4py.sklearn.linear_model.logistic_regression_path`
9. `daal4py.sklearn.linear_model.LogisticRegression`

Source: <https://intelpython.github.io/daal4py/sklearn.html> (last accessed July 7, 2020)

Direct Infringement Allegations

55. On information and belief, Intel's infringing products contain substantially similar componentry and functionality at least insofar as the claimed inventions are concerned. The allegations below illustrate how Intel's infringing products (*e.g.*, processors, FPGAs, SoCs, and Software) embody the claimed computer-implemented methods. Reasonable discovery will confirm these interpretations. Such infringement by these products is exemplified through the independent claims of the '188 patent, which are representative of the scope of Intel's infringement.
56. As Defendant Intel is in the sole and complete possession of its relevant source code, algorithms, etc., with such information not publicly available, Plaintiff HDC respectfully requests early, limited discovery pursuant to Western District of Texas Local Rules (*i.e.*,

Order Governing Procedures – Patent Case) to confirm which Intel products or uses infringe. The Local Rules state:

Except with regard to discovery necessary for claim construction, all other discovery is stayed until after the Markman hearing. Notwithstanding this general stay of discovery, the Court will permit limited discovery by agreement of the parties, or upon request, where exceptional circumstances warrant.

57. Plaintiff HDC is requesting early discovery to confirm exactly which Intel products or uses of the SVM-RFE invention infringe the ‘188 patent. Due to the nature of Intel’s business, the information required to determine exactly which Intel products or uses infringe is, in large part, not publicly available. However, although said information is not publicly available, Intel has publicly admitted (on several occasions) that it uses/used SVM-RFE in the development and optimization of its products (software, hardware, packages, libraries, etc.). HDC did not authorize Intel’s use of SVM-RFE, for any reason, and therefore Intel’s admissions of using SVM-RFE makes it highly probable that Intel is infringing the ‘188 patent. Intel may also be using the SVM-RFE technology, but referring to it by a different name to conceal infringing activities. The following citations, *inter alia*, include examples of Intel’s admissions in the past, and there is no reason to believe they have ceased using the invention. *Supra* ¶ 35 for additional publications.

- a. A. Jaleel, et al., “Last Level Cache (LLC) Performance in Data Mining Workloads on a CMP – A Case Study of Parallel Bioinformatics Workloads,” *Proc. of the 12th Int’l Symp. on High Performance Computer Architecture (HPCA)*, 2006. [2 of 3 authors were Intel employees]. **Exhibit N.**
- b. Y. Chen, et al., “Performance Scalability of Data-Mining Workloads in Bioinformatics,” *Intel Technology Journal*, Vol. 9, No. 2, May 19, 2005. [9 of 9

authors were Intel employees, including the two named inventors of Intel SVM-RFE patent US7,685,077]. **Exhibit I.**

- c. U. Srinivasan, et al., “Characterization and Analysis of HMMER and SVM-RFE Parallel Bioinformatics Applications,” *Proc. of the IEEE Int’l Symp. on Workload Characterization (IISWC)*, Oct. 2005. [8 of 8 authors were Intel employees; including the two named inventors of Intel SVM-RFE patent US7,685,077] [In endnote 7, authors attribute SVM-RFE to Guyon and Weston, two of the named inventors of the ‘188 patent]. **Exhibit J.**

58. On information and belief, Defendant Intel performs each limitation of claim 1 of the ‘188 patent:

“1. A computer-implemented method for identifying patterns in data, the method comprising:

(a) inputting into at least one support vector machine of a plurality of support vector machines a training set having known outcomes, the at least one support vector machine comprising a decision function having a plurality of weights, each having a weight value, wherein the training set comprises features corresponding to the data and wherein each feature has a corresponding weight;

(b) optimizing the plurality of weights so that classifier error is minimized;

(c) computing ranking criteria using the optimized plurality of weights;

(d) eliminating at least one feature corresponding to the smallest ranking criterion;

(e) repeating steps (a) through (d) for a plurality of iterations until a subset of features of pre-determined size remains; and

(f) inputting into the at least one support vector machine a live set of data wherein the features within the live set are selected according to the subset of features.”

59. On information and belief, Defendant Intel’s accused products and software, through their optimization, development, sale, and operation, embody a computer implemented method for identifying patterns in data. Reasonable discovery will confirm this interpretation. As evidence, and for example, one such computer-implemented method from the bioinformatics community was conducted by Intel engineers on a liver patient dataset to predict whether a person has liver disease (hereinafter “*liver patient dataset*”). See

<<https://software.intel.com/content/www/us/en/develop/articles/liver-patient-dataset-classification-using-the-intel-distribution-for-python.html>> at page 1 (published May 3, 2018). As an additional example, one such computer-implemented method from the financial metrics community was conducted by Intel engineers on a credit risk dataset to predict whether a person is a good credit risk or not (hereinafter “*credit risk dataset*”) (published April 20, 2018).

“Using the advantage of optimized scikit-learn* (Scikit-learn with Intel DAAL) that comes with Intel® Distribution for Python, we were able to achieve good results for the prediction problem.”

Source:< <https://software.intel.com/content/www/us/en/develop/articles/credit-risk-classification-faster-machine-learning-with-intel-optimized-packages.html>> p.1

“Using Intel optimized performance libraries in Intel® Xeon® Gold 6128 processor helped machine-learning applications to make predictions faster.”

Source:< <https://software.intel.com/content/www/us/en/develop/articles/credit-risk-classification-faster-machine-learning-with-intel-optimized-packages.html>> p.10

60. On information and belief, Defendant Intel’s accused products and software, through their optimization, development, sale, and operation, embody a computer implemented method for (a) inputting into at least one support vector machine of a plurality of support vector machines a training set having known outcomes, the at least one support vector machine comprising a decision function having a plurality of weights, each having a weight value, wherein the training set comprises features corresponding to the data and wherein each feature has a corresponding weight. Reasonable discovery will confirm this interpretation. As evidence, and for example, Intel used the *liver patient dataset* comprising a plurality of features (*e.g.*, ten), and two classes (*e.g.*, liver patient or not) as shown in Table 2 below:

Liver Patient Dataset

Table 2. Dataset description.

Attribute Name	Attribute Description
V1	Age of the patient. Any patient whose age exceeded 89 is listed as being age 90.
V2	Gender of the patient
V3	Total bilirubin
V4	Direct bilirubin
V5	Alkphos alkaline phosphatase
V6	Sgpt alanine aminotransferase
V7	Sgot aspartate aminotransferase
V8	Total proteins
V9	Albumin
V10	A/G ratio albumin and globulin ratio
Class	Liver patient or not

Source:< <https://software.intel.com/content/www/us/en/develop/articles/liver-patient-dataset-classification-using-the-intel-distribution-for-python.html> > p.2

Feature selection is used to identify the most important features in the dataset that can build the model from the dataset.

“Feature selection is mainly applied to large datasets to reduce high dimensionality. This helps to identify the most important features in the dataset that can be given for model building.”

Source:< <https://software.intel.com/content/www/us/en/develop/articles/liver-patient-dataset-classification-using-the-intel-distribution-for-python.html> > p.4

In the *liver patient dataset* example described by Intel engineers, they used the random forest algorithm (a classifier) in order to visualize feature importance. However, as shown in the graphical data below for the receiver operating characteristics (ROC), additional classifiers were used on the *liver patient dataset*, including a support vector machine (SVM).

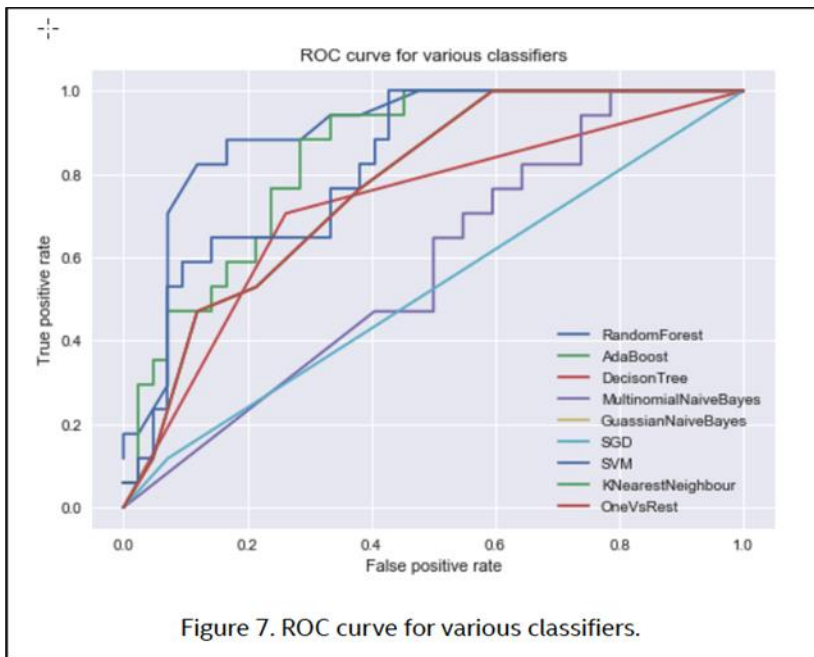

Source: <<https://software.intel.com/content/www/us/en/develop/articles/liver-patient-dataset-classification-using-the-intel-distribution-for-python.html>> p.4

For the *credit risk dataset*, Intel’s classification comprised a plurality of features (*e.g.*, 21), and two classes (*e.g.*, good credit or bad credit) as shown in Table 3 below:

Credit Risk Dataset

Table 3. Dataset Description.

Attribute Name	Attribute Description
checking_status	Status of existing checking account, in Deutsche Marks (DM)
duration	Duration in months
credit_history	Credit history (credits taken, paid back duly, delays, critical accounts)
purpose	Purpose of the credit (car, television, etc.)
credit_amount	Credit loan amount, in Deutsche Marks (DM)
savings_status	Status of savings account and bonds, in Deutsche Marks
employment	Present employment, in number of years
installment_commitment	Installment rate in percentage of disposable income
personal_status	Personal status (married, single, etc.) and sex
other_parties	Other debtors and guarantors
residence_since	Present residence since X years
property_magnitude	Property (e.g., real estate)
age	Age in years
other_payment_plans	Other installment plans (banks, stores, etc.)
housing	Housing (rent, own)
existing_credits	Number of existing credits at this bank
job	Job
num_dependents	Number of people being liable to provide maintenance for
own_telephone	Telephone (yes and no)
foreign_worker	Foreign worker (yes and no)
class	Good credit or bad credit

Source: < <https://software.intel.com/content/www/us/en/develop/articles/credit-risk-classification-faster-machine-learning-with-intel-optimized-packages.html>> p.2-3

As shown in the graph below for the receiver operating characteristics (ROC), one of the support vector classifiers for the *credit risk dataset* is a support vector machine (SVM).

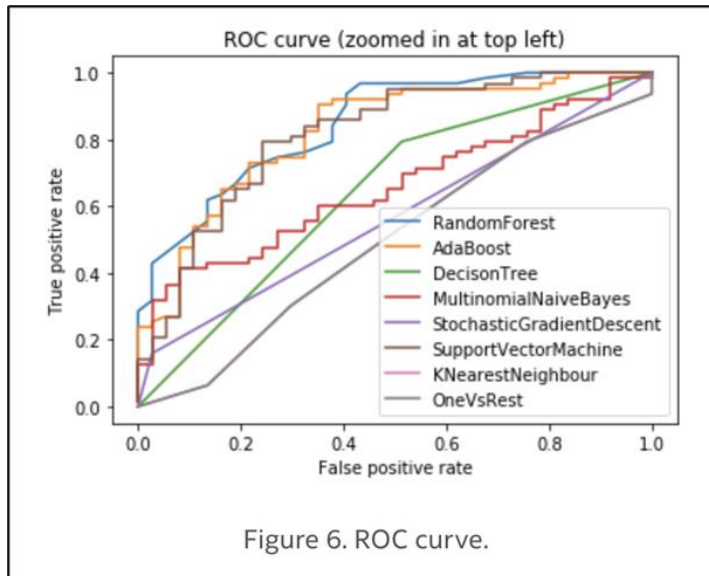

Figure 6. ROC curve.

Source:< <https://software.intel.com/content/www/us/en/develop/articles/credit-risk-classification-faster-machine-learning-with-intel-optimized-packages.html> > at p.9

61. On information and belief, Defendant Intel’s accused products and software, through their optimization, development, sale, and operation, embody a computer implemented method for (b) optimizing the plurality of weights so that classifier error is minimized. For example, and on information and belief, Intel optimizes the plurality of weights and determines the relative importance of the features within their processors, FPGAs, SoCs, and/or software using Scikit-Learn (a machine learning library) function – ExtraTreesClassifier(). While Intel may have used this function in relation to an alternate feature selection algorithm, as shown above Intel has used up to eight other classifiers including SVM during the *liver patient dataset* analysis.

“The ExtraTreesClassifier() function from the sklearn.ensemble package is used for calculation.”

Source:< <https://software.intel.com/content/www/us/en/develop/articles/liver-patient-dataset-classification-using-the-intel-distribution-for-python.html> > p.4

In the *liver patient dataset* method, 90% of the dataset was used to train the model, and 10% was used for testing/predicting the model outcomes. Another scikit-learn (a machine learning library) function was used to split the training and test data – StratifiedShuffleSplit.

“A part of the whole dataset was given for training the model and the rest was given for testing. In this experiment, 90 percent of the data was given for training and 10 percent for testing. Since StratifiedShuffleSplit (a function in scikit-learn) was applied to split the train-test data, the percentage of samples for each class was preserved, that is, in this case, 90 percent of samples from each class was taken for training and the remaining 10 percent from each class was given for testing. Classifiers from the scikit-learn package were used for model building.”

Source: <<https://software.intel.com/content/www/us/en/develop/articles/liver-patient-dataset-classification-using-the-intel-distribution-for-python.html>> p.5

For the *credit risk dataset* example, and on information and belief, the method included optimizing the plurality of weights and determining the relative importance of the features is calculated using scikit-learn.

“Classifier is implemented using two packages: scikit-learn with Intel DAAL and PyDAAL.”

Source: <<https://software.intel.com/content/www/us/en/develop/articles/credit-risk-classification-faster-machine-learning-with-intel-optimized-packages.html>> p.7

In the *credit risk dataset* method, 90% of the dataset was used to train the model, and 10% was used for testing/predicting the model outcomes.

“Data Split

Splitting the train and test data: The data is then split into train and test sets for further analysis. 90% of the data is used for training and 10% is for testing. The train_test_split function in scikit-learn is used for data splitting.”

Source: <<https://software.intel.com/content/www/us/en/develop/articles/credit-risk-classification-faster-machine-learning-with-intel-optimized-packages.html>> p.7

62. On information and belief, Defendant Intel’s accused products and software, through their optimization, development, sale, and operation, embody a computer implemented method for (c) computing ranking criteria using the optimized plurality of weights. Reasonable

discovery will confirm this interpretation. As evidence, and for the *liver patient dataset* example, the rankings were computed and plotted on the graph shown in Figure 5 below, showing the relative importance of the features. Note, while Intel may have used the forest of trees algorithm for feature importance, as shown above Intel has used up to eight other classifiers including SVM during the *liver patient dataset* analysis.

Liver Patient Dataset

“Figure 5 shows the feature importance with forests of trees. From the figure, it is clear that the most important feature is V5 (alkphos alkaline phosphatase) and the least important is V2 (gender).”

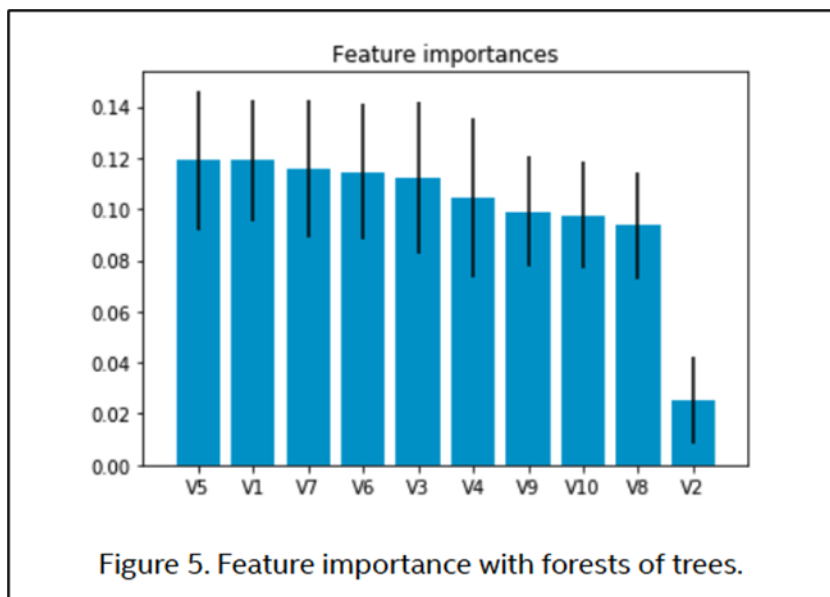

Source: <https://software.intel.com/content/www/us/en/develop/articles/liver-patient-dataset-classification-using-the-intel-distribution-for-python.html> at p.4

For the *credit risk dataset* example, the rankings were computed and plotted on the graph shown in Table 5 below, showing the relative importance of the features.

Credit Risk Dataset

Table 5. Feature Importance.

Feature	Score
credit_amount	0.1724
duration	0.1122
age	0.1057
purpose	0.0634
checking_status_no checking	0.0423
installment_commitment	0.0341
plan_none	0.0309
employment_4<=X<7	0.0293
residence_since	0.0260
credit_history_all paid	0.0244

Source: <https://software.intel.com/content/www/us/en/develop/articles/credit-risk-classification-faster-machine-learning-with-intel-optimized-packages.html> at p.4

63. On information and belief, Defendant Intel’s accused products and software, through their optimization, development, sale, and operation, embody a computer implemented method for (d) eliminating at least one feature corresponding to the smallest ranking criterion. Reasonable discovery will confirm this interpretation. As evidence, and for *liver patient dataset* example, features with the smallest ranking criteria were made available to be eliminated, in this case it was V2 (gender of the patient), V8 (total proteins), V10 (A/G ratio albumin and globulin ratio), and V9 (albumin).

“Removing the least significant features help to reduce the processing time without significantly affecting the accuracy of the model. Here V2 (gender of the patient), V8 (total proteins), V10 (A/G ratio albumin and globulin ratio), and V9 (albumin) are dropped in order to reduce the number of features for model building.”

Source: <https://software.intel.com/content/www/us/en/develop/articles/liver-patient-dataset-classification-using-the-intel-distribution-for-python.html> at p.4

The *credit risk dataset* example also used such a ranking criterion.

Feature Selection

“Datasets may contain irrelevant or redundant features that might make the machine-learning model more complicated. **In this step, we aim to remove the irrelevant features which may cause an increase in run time, generate complex patterns, etc.**”

Source: <https://software.intel.com/content/www/us/en/develop/articles/credit-risk-classification-faster-machine-learning-with-intel-optimized-packages.html> at p.6 (emphasis added)

64. On information and belief, Defendant Intel’s accused products and software, through their optimization, development, sale, and operation, embody a computer implemented method for (e) repeating steps (a) through (d) for a plurality of iterations until a subset of features of pre-determined size remains. Reasonable discovery will confirm this interpretation. On information and belief, and for example, the process of computing ranking criteria and eliminating the features with smaller ranking criteria, can be continued until the desired subset of features remains. In the *liver patient dataset*, there were four smaller ranking features, which could have been eliminated in one round, or several rounds of ranking and eliminating, depending on the engineer’s desired protocol.

“Removing the least significant features help to reduce the processing time without significantly affecting the accuracy of the model. Here V2 (gender of the patient), V8 (total proteins), V10 (A/G ratio albumin and globulin ratio), and V9 (albumin) are dropped in order to reduce the number of features for model building.”

Source: <https://software.intel.com/content/www/us/en/develop/articles/liver-patient-dataset-classification-using-the-intel-distribution-for-python.html> at p.4

Similar to the *liver patient dataset* example, and on information and belief, during the *credit risk dataset*, computing ranking criteria and eliminating the features with smaller ranking criteria, can be continued until the desired subset of features remains. For the *credit risk dataset*, when the irrelevant features were removed, the classifier performance improved slightly, but there was a significant improvement in run time, due to the reduced feature set.

“There was only a slight improvement in classifier performance when the **irrelevant features were removed**, but there was a significant improvement in run time.”

Source: <https://software.intel.com/content/www/us/en/develop/articles/credit-risk-classification-faster-machine-learning-with-intel-optimized-packages.html> at p.9 (emphasis added)

65. On information and belief, Defendant Intel’s accused products and software, through their optimization, development, sale, and operation, embody a computer implemented method for (f) inputting into the at least one support vector machine a live set of data wherein the features within the live set are selected according to the subset of features. Reasonable discovery will confirm this interpretation. As evidence, and for the *liver patient dataset* example, the figure below illustrates the receiver operating characteristic (ROC), of the various classifiers. The ROC curve is created by plotting the true positive rate against the false positive rate at various threshold settings. As shown in the graph below for the receiver operating characteristics (ROC), one of the support vector classifiers for the *liver patient dataset* is a support vector machine (SVM).

Liver Patient Dataset

“The ROC curves for various classifiers are given in figure 7. The classifier output quality of different classifiers can be evaluated using this.”

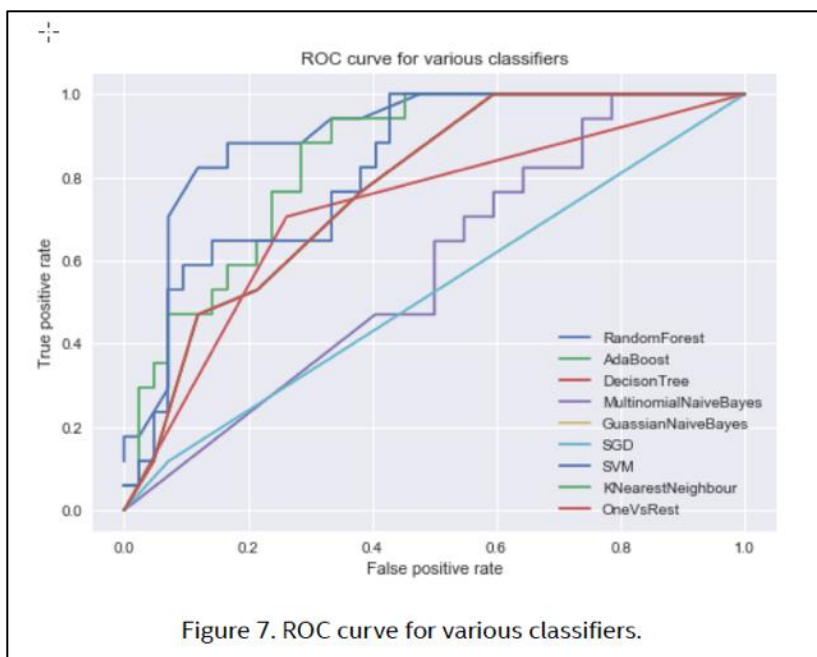

Source: <https://software.intel.com/content/www/us/en/develop/articles/liver-patient-dataset-classification-using-the-intel-distribution-for-python.html> at p.8

For the *credit risk dataset* example, the figure below illustrates the receiver operating characteristic (ROC), of the various classifiers. The ROC curve is created by plotting the true positive rate against the false positive rate at various threshold settings. One of those classifiers for the *credit risk dataset* is a Support Vector Machine (SVM).

Credit Risk Dataset

“Figure 6 shows the ROC curve for classifiers in scikit-learn with Intel® DAAL. ROC curve demonstrates that Random Forest Classifier and Ada Boost classifier are the best classifiers.”

Source: <https://software.intel.com/content/www/us/en/develop/articles/credit-risk-classification-faster-machine-learning-with-intel-optimized-packages.html> at p.9

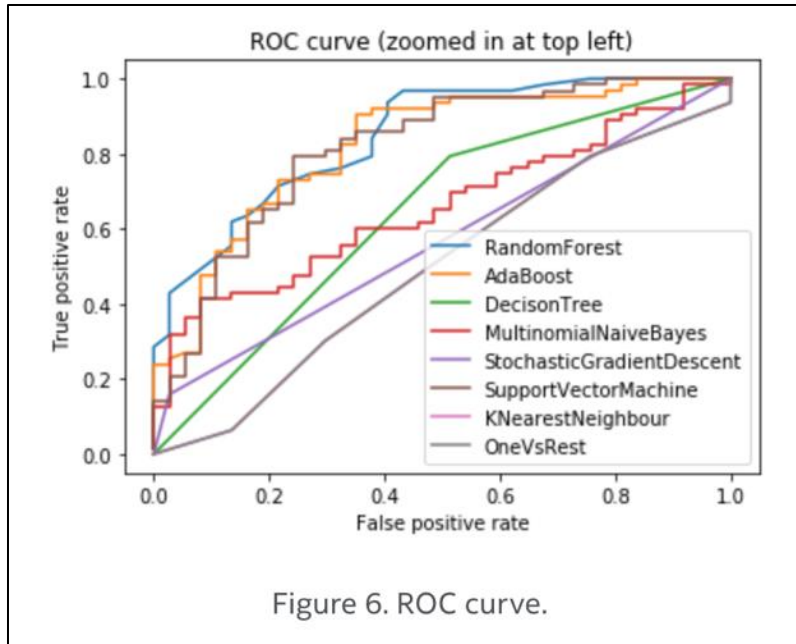

Source: <https://software.intel.com/content/www/us/en/develop/articles/credit-risk-classification-faster-machine-learning-with-intel-optimized-packages.html> at p.9

66. On information and belief, Defendant Intel performs each limitation of claim 13 of the

‘188 patent:

“13. A computer-implemented method for identifying determinative genes for use in diagnosis, prognosis or treatment of a disease, the method comprising:

(a) inputting into a support vector machine a training data set of gene expression data having known outcomes with respect to the disease, the support vector machine comprising a decision function having a plurality of weights, each having a weight value, wherein the training set comprises features corresponding to the gene expression data and each feature has a corresponding weight;

(b) optimizing the plurality of weights so that classifier error is minimized;

(c) computing ranking criteria using the optimized plurality of weights;

(d) eliminating at least one feature corresponding to the smallest ranking criterion;

(e) repeating steps (a) through (d) for a plurality of iterations until an optimum subset of features remains; and

(f) inputting into the support vector machine a live data set of gene expression data wherein the features within the live data set are selected according to the optimum subset of features.”

67. On information and belief, Defendant Intel performs each limitation of claim 19 of the

‘188 patent:

“19. A computer-implemented method for identifying patterns in biological data, the method comprising:

(a) inputting into at least some of a plurality of support vector machines a training data set, wherein the training data set comprises features corresponding to the biological data and each feature has a corresponding weight, and wherein each support vector machine comprises a decision function having a plurality of weights;

(b) optimizing the plurality of weights so that classification confidence is optimized;

(c) computing ranking criteria using the optimized plurality of weights;

(d) eliminating at least one feature corresponding to the smallest ranking criteria;

(e) repeating steps (a) through (d) for a plurality of iterations until an optimum subset of features remains; and

(f) inputting into the plurality of support vector machines a live set of biological data wherein the features within the live set are selected according to the optimum subset of features.”

68. As alleged in ¶¶ 66 and 67, independent claims 13 and 19 are computer-implemented method claims for identifying patterns in data, and are of similar content and scope to claim 1 of the ‘188 patent, with just slight differences related to the type of datasets upon which the SVM-RFE method is implemented. Accordingly, the direct infringement allegations of ¶¶ 59-65 are incorporated by reference herein and apply to claims 13 and 19. Defendant Intel’s accused products and software perform and infringe each limitation of claim 13 and each limitation of claim 19.

69. On information and belief, Defendant Intel’s accused products and software embody each limitation of the dependent claims 2-12, 14-18, and 20-23 of the ‘188 patent. Reasonable discovery will confirm this interpretation and confirm exactly which Intel products implement and use (in testing, validating, verifying, optimizing, operating, etc.) HDC’s patented SVM-RFE machine-learning algorithm.

Defendant’s Direct Infringement of the Method Claims

70. Defendant performs the methods recited in claims 1-23 of the ‘188 patent. Infringement of a method claim requires performing every step of the claimed method. Defendant performs every step of the methods recited in claims 1-23. As set forth above, Defendant

performs, for example, the method recited in claim 1, *i.e.*, a computer-implemented method for identifying patterns in data, the method comprising: (a) inputting into at least one support vector machine of a plurality of support vector machines a training set having known outcomes, the at least one support vector machine comprising a decision function having a plurality of weights, each having a weight value, wherein the training set comprises features corresponding to the data and wherein each feature has a corresponding weight; (b) optimizing the plurality of weights so that classifier error is minimized; (c) computing ranking criteria using the optimized plurality of weights; (d) eliminating at least one feature corresponding to the smallest ranking criterion; (e) repeating steps (a) through (d) for a plurality of iterations until a subset of features of pre-determined size remains; and (f) inputting into the at least one support vector machine a live set of data wherein the features within the live set are selected according to the subset of features.

71. Even if one or more steps recited in method claims 1-23 of the '188 patent are performed on technologies, computers, workstations, network-computer architectures, cloud-based architectures, etc., not in the physical possession of the Defendant (*e.g.*, in the possession of Intel partners, resellers, end-users, etc.), the claimed methods are specifically performed by Intel's processors, FPGAs, SoCs, and/or software. Defendant directly infringes as its processors, FPGAs, SoCs, and/or software dictate the performance of the claimed steps, such as the "inputting," "optimizing," "computing," "eliminating," "repeating," and "inputting" steps recited in claim 1 of the '188 patent. Defendant's processors, FPGAs, SoCs, and/or software are designed and built by Defendant to perform the claimed steps automatically. Such processors, FPGAs, SoCs, and/or software identify patterns in data. On information and belief, only Defendant can modify the functionality

relating to these activities; no one else can modify such functionality. Defendant therefore performs all of the claimed steps and directly infringes the asserted method claims of the '188 patent.

72. ***Additionally or alternatively***, to the extent third parties or end-users perform one or more steps of the methods recited in claims 1-23 of the '188 patent, any such action by third parties or end-users is attributable to Defendant, such that Defendant is liable for directly infringing such claims in a multiple actor or joint infringement situation, because Defendant directs or controls the other actor(s). In this regard, Defendant conditions participation in activities, as well as the receipt of benefits, upon performance of any such step by any such third party or end-user. Defendant exercises control over the methods performed by its processors, FPGAs, SoCs, and/or software and benefit from others' use, including without limitation creating and receiving ongoing revenue streams from the accused products and related goods, and improvement/enhancement of its processors, FPGAs, SoCs, and/or software. End-users and third parties receive a benefit from fiscal gains (*e.g.*, third-party developers embedding Defendant's processors, FPGAs, SoCs, and/or software in their own products) and efficient and optimized data output – which forms the basis of entire businesses. Defendant also establishes the manner and timing of that performance by the third-party or end-user, as dictated by the claimed method steps. All third-party and end-user involvement, if any, is incidental, ancillary, or contractual.
73. Thus, to the extent that any step of the asserted method claims is performed by someone other than Defendant (*e.g.*, an end-user), Defendant nonetheless directly infringes the '188 patent at least by one or more of: (1) providing processors, FPGAs, SoCs, and/or software built and designed to perform methods covered by the asserted method claims; (2)

dictating via software and associated directions and instructions (*e.g.*, to end-users) the use of the accused products such that, when used as built and designed by Defendant, such products perform the claimed methods; (3) having the ability to terminate others' access to and use of the accused products and related goods and services if the accused products are not used in accordance with Defendant's required terms; (4) marketing and advertising the accused products, and otherwise instructing and directing the use of the accused products in ways covered by the asserted method claims; and (5) updating and providing ongoing support and maintenance for the accused products.

Induced Infringement

74. Defendant has induced and will continue to induce others' infringement of claims 1-23 of the '188 patent, in violation of 35 U.S.C. § 271(b). Defendant has actively encouraged infringement of the '188 patent, knowing that the acts it induced constituted infringement of the '188 patent, and its encouraging acts actually resulted in direct patent infringement by others.
75. As discussed above, Defendant had actual and constructive knowledge of the '188 patent, as well as actual and constructive knowledge of the relevance and significance of the '188 patent to its research and development, as well as its product offerings, at least no later than May 15, 2008 (per Intel's IDS solely citing the '188 patent), and certainly no later than November 10, 2011 (per HDC direct correspondence).
76. To the extent Defendant do not specify and control the relevant algorithms and machine learning capabilities of the accused products in the claimed manner (which it does), Defendant—with full knowledge of the '188 patent and its relevance to its product offerings—actively encourages others (*e.g.*, end-users and third parties such as

professionals, businesses, developers, Intel partners, etc.)—to use the accused products as claimed. Such active encouragement by Defendant takes many forms, and includes promotional and instructional materials, as well as technical specifications and requirements, and continuing technical assistance.

77. On information and belief, Defendant engaged in these acts with the actual intent to cause the acts which it knew or should have known would induce actual infringement, or otherwise exercised willful blindness of a high probability that it has induced infringement.

Contributory Infringement

78. Defendant has contributed and will continue to contribute to others' infringement of claims 1-23 of the '188 patent, in violation of 35 U.S.C. § 271(c). Defendant has offered to sell and sold within the United States, or imported into the United States, material or apparatus for use in practicing the patented computer-implemented methods, constituting a material part of the patented methods, knowing the same to be especially made or especially adapted for use in infringing the '188 patent, and not a staple article or commodity of commerce for substantial non-infringing use.
79. As discussed above, Defendant had actual and constructive knowledge of the '188 patent, as well as actual and constructive knowledge of the relevance and significance of the '188 patent to its research and development, as well as its product offerings, at least no later than May 15, 2008 (per Intel's IDS solely citing the '188 patent), and certainly no later than November 10, 2011 (per HDC direct correspondence).
80. To the extent Defendant do not specify and control the relevant algorithms and machine learning capabilities of the accused products in the claimed manner (which it does),

Defendant supplies the accused products to others (*e.g.*, end-users and third parties) that perform the claimed data pattern identification and optimization, and/or that, when combined with other components, constitute the claimed computer implemented methods. The accused products embody SVM-RFE processes, which constitute a material part of the claimed inventions, if not the entire claimed inventions themselves. Defendant dictates and controls the optimization and identification componentry and techniques in the accused products, with full knowledge of the '188 patent and its relevance to its research development, as well as its product offerings, and know the same to be especially made and especially adapted for the infringement of the '188 patent.

81. On information and belief, the portions of Defendant's products that identify patterns in data and implement SVM-RFE, including Intel branded products made, marketed, used, sold, offered to sell, or imported by Defendant, are not staple articles or commodities of commerce suitable for substantial non-infringing use.

Willful Infringement

82. As set forth above, Defendant had actual and constructive knowledge of the '188 patent, as well as actual and constructive knowledge of the relevance and significance of the '188 patent to its research and development, as well as its product offerings, at least no later than May 15, 2008 (per Intel's IDS solely citing the '188 patent), and certainly no later than November 10, 2011 (per HDC direct correspondence).
83. Still further, as set forth in ¶¶ 30-31 *supra*, Plaintiff and Defendant were engaged in an Interference proceeding in the USPTO, that began on September 19, 2016 and ended in February 2019. On February 27, 2019, the USPTO ruled in favor of Health Discovery Corporation on the SVM-RFE Patent application, finding that Health Discovery

Corporation was entitled to claim exclusive ownership rights to the SVM-RFE technology as set forth in the SVM-RFE Patent application that was filed to provoke the Interference. The decision ordered Intel Corporation's Patent No. 7,685,077 to be cancelled. The decision also dismissed Intel Corporation's motions challenging the validity of Health Discovery Corporation's pending claims and issued patents covering SVM-RFE. On September 3, 2019, the USPTO issued U.S. Patent No. 10,402,685 ("SVM-RFE Patent") (one of the Patents-in-Suit) for Health Discovery Corporation's patent application covering SVM-RFE methods.

84. Defendant therefore had continuing actual and constructive knowledge of HDC's SVM-RFE patent portfolio, which included the '188 patent, and the relevance and significance of the SVM-RFE portfolio to Intel's research and development.
85. Defendant's infringement, as demonstrated above, is egregious, and combined with Defendant's clear knowledge, has been willful. Plaintiff respectfully requests that the Court award enhanced damages based on Defendant's conduct.

Damage to Health Discovery Corporation

86. On information and belief, Defendant's actions have and will continue to constitute direct and indirect (induced and contributory) infringement of at least claims 1-23 of the '188 patent in violation of 35 U.S.C. §271.
87. As a result of Defendant's infringement of at least claims 1-23 of the '188 patent, HDC has suffered monetary damages in an amount yet to be determined, in no event less than a reasonable royalty, and will continue to suffer damages in the future unless Defendant's infringing activities are enjoined by this Court.

88. Defendant's wrongful acts have damaged and will continue to damage HDC irreparably, and Plaintiff has no adequate remedy at law for those wrongs and injuries. In addition to its actual damages, Plaintiff HDC is entitled to a permanent injunction restraining and enjoining Defendant and its respective agents, servants, and employees, and all person acting thereunder, in concert with, or on its behalf, from infringing at least claims 1-23 of the '188 patent.

COUNT II
INFRINGEMENT OF THE '959 PATENT

89. Plaintiff HDC repeats and realleges the above paragraphs, which are incorporated by reference as if fully restated herein.

90. Plaintiff HDC is the owner by assignment of all right, title, and interest in the '959 patent, including all right to recover for any and all infringement thereof.

91. Defendant is not licensed or otherwise authorized to practice the '959 patent.

92. The '959 patent is valid and enforceable. In this regard, the '959 patent is presumed valid under 35 U.S.C. §282.

93. The '959 patent relates to, among other things, a method, computer program product, and apparatus for using learning machines (*e.g.*, Support Vector Machines) to identify relevant patterns in datasets and select relevant features within the datasets to optimize data classification (*e.g.*, as Recursive Feature Elimination). The '959 patent invented such method, product, and apparatus, for example, to identify patterns in biological systems (*e.g.*, genes, gene products, proteins, lipids, and combinations of the same) to help, *e.g.*, diagnose and predict abnormal physiological states.

94. On information and belief, Defendant manufactures and markets infringing products. *See*, ¶¶ 52-54, *supra*. Such products infringe on the inventive aspects of the '959 patent and

include, *inter alia*, Intel processors (e.g., Intel Xeon series; etc.), Intel Field Programmable Gate Arrays (FPGAs) and System on Chips (SoCs) (e.g., Intel Agilex Series; Intel Stratix Series; etc.), and Intel software (e.g., Intel Data Analytics Acceleration Library). Intel processors, FPGAs, SoCs, and software are deployed in Intel/Intel-partnered computers, workstations, network-computer architectures, and cloud-based architectures.

95. The '959 patent is well-known in the SVM-RFE industry. It has been cited in at least 74 U.S. patents and patent applications, including patents and patent applications filed by industry leaders, such as Google Inc., Microsoft Corporation, and International Business Machines Corporation.

96. The '959 patent was cited in at least two Intel Corporation patents via family-to-family citations, including:

- a. U.S. Patent No. 7,146,050, "Facial Classification of Static Images Using Support Vector Machines," with a publication date of December 5, 2006.
- b. U.S. Patent No. 7,174,040, "Fast Method for Training and Evaluating Support Vector Machines with a Large Set of Linea Features," with a publication date of February 6, 2007.

97. The '959 patent was cited in at least one Intel Corporation scholarly article written by 9 Intel employees, which included the two named inventors of Intel's SVM-RFE U.S. Patent No. 7,685,077, which was the subject of the Interference Proceeding in the USPTO:

- a. Y. Chen, et al., "Performance Scalability of Data-Mining Workloads in Bioinformatics," *Intel Technology Journal*, Vol. 9, No. 2, May 19, 2005. **Exhibit I.**

98. Moreover, Plaintiff HDC began corresponding with Defendant about the SVM-RFE patents, including the '959 patent, in November 2011. Specifically, HDC sent a letter to Steven Rodgers on November 10, 2011, advising of a reexamination of Intel Patent No. 7,685,077, and a filing to provoke an interference with the '077 patent. On information and belief, Steven Rodgers was Intel's Vice President of Legal and Corporate Affairs in November 2011. At the time of this filing, Rodgers is now Executive Vice President and General Counsel for Intel.
99. Therefore, Defendant had actual and constructive knowledge of the '959 patent, as well as actual and constructive knowledge of the relevance and significance of the '959 patent to its research and development, as well as its product offerings, at least no later than May 19, 2005 (per scholarly article), no later than December 5, 2006 (per family-to-family USPTO citation), and certainly no later than November 10, 2011 (per HDC direct correspondence).

Defendant's Direct Infringement of the '959 Patent

100. On information and belief, in violation of 35 U.S.C. § 271(a), Defendant has directly infringed, continues to directly infringe, and will continue to directly infringe, absent the Court's intervention, one or more claims of the '959 patent, including for example (but not limited to) at least computer-implemented method claims 1-11, computer program product claims 12-15, and apparatus claims 16-19 of the '959 patent, either literally or under the doctrine of equivalents, by making, using, testing, selling, and/or offering to sell within the United States, or importing into the United States, without license or authority, Defendant's infringing products, including, but not limited to, at least Intel AI-optimizing/machine learning processors, FPGAs, SoCs, and/or software – which

are, *inter alia*, deployed in Intel/Intel-partnered computers, workstations, network-computer architectures, and cloud-based architectures. Defendant's infringing products also include software applications or libraries that incorporate SVM-RFE algorithms, such as Intel's Data Analytics Acceleration Library (DAAL) that utilizes SVM-RFE algorithms contained in the scikit-learn open source software. The following products and software are representative, *see* paragraphs 52-54 *supra*, of Intel's infringement.

Direct Infringement Allegation

101. On information and belief, Intel's infringing products contain substantially similar componentry and functionality at least insofar as the claimed inventions are concerned. The allegations illustrate how Intel's infringing products (*e.g.*, processors, FPGAs, SoCs, and Software) embody the claimed computer-implemented methods, computer program products, and apparatuses. Such infringement by these products is exemplified through the independent claims of the '959 patent, which are representative of the scope of Intel's infringement.

102. As Defendant Intel is in the sole and complete possession of its relevant infringing source code, algorithms, etc., with such information not publicly available, Plaintiff HDC respectfully requests early, limited discovery to confirm which Intel products and uses by Intel infringe. *See* ¶ 56.

103. Plaintiff HDC is requesting early discovery to confirm exactly which Intel products or uses of the SVM-RFE invention infringe the '959 patent. Due to the nature of Intel's business, the information required to determine exactly which Intel products or uses infringe is, in large part, not publicly available. However, although said information is not publicly available, Intel has publicly admitted (on several occasions) that it uses/used

SVM-RFE in the development and optimization of its products (software, hardware, packages, libraries, etc.). HDC did not authorize Intel's use of SVM-RFE, for any reason, and therefore Intel's admissions of using SVM-RFE makes it highly probable that Intel is infringing the '959 patent. Intel may also be using the SVM-RFE technology, but referring to it by a different name to conceal infringing activities. The following citations, *inter alia*, include examples of Intel's admissions in the past, and there is no reason to believe they have ceased using the invention. *Supra* ¶ 35 for additional publications.

- a. A. Jaleel, et al., "Last Level Cache (LLC) Performance in Data Mining Workloads on a CMP – A Case Study of Parallel Bioinformatics Workloads," *Proc. of the 12th Int'l Symp. on High Performance Computer Architecture (HPCA)*, 2006. [2 of 3 authors were Intel employees]. **Exhibit N.**
 - b. Y. Chen, et al., "Performance Scalability of Data-Mining Workloads in Bioinformatics," *Intel Technology Journal*, Vol. 9, No. 2, May 19, 2005. [9 of 9 authors were Intel employees, including the two named inventors of Intel SVM-RFE patent US7,685,077]. **Exhibit I.**
 - c. U. Srinivasan, et al., "Characterization and Analysis of HMMER and SVM-RFE Parallel Bioinformatics Applications," *Proc. of the IEEE Int'l Symp. on Workload Characterization (IISWC)*, Oct. 2005. [8 of 8 authors were Intel employees; including the two named inventors of Intel SVM-RFE patent US7,685,077] [In endnote 7, authors attribute SVM-RFE to Guyon and Weston, two of the named inventors of the '959 patent]. **Exhibit J.**
104. On information and belief, Defendant Intel performs each limitation of claim 1 of the '959 patent:

“1. A computer-implemented method for predicting patterns in biological data, wherein the data comprises a large set of features that describe the data and a sample set from which the biological data is obtained is much smaller than the large set of features, the method comprising:

identifying a determinative subset of features that are most correlated to the patterns comprising:

(a) inputting the data into a computer processor programmed for executing support vector machine classifiers;

(b) training a support vector machine classifier with a training data set comprising at least a portion of the sample set and having known outcomes with respect to the patterns, wherein the classifier comprises weights having weight values that correspond to the features in the data set and removal of a subset of features affects the weight values;

(c) ranking the features according to their corresponding weight values;

(d) removing one or more features corresponding to the smallest weight values;

(e) training a new classifier with the remaining features;

(f) repeating steps (c) through (e) for a plurality of iterations until a final subset having a pre-determined number of features remains; and

generating at a printer or display device a report comprising a listing of the features in the final subset, wherein the final subset comprises the determinative subset of features for determining biological characteristics of the sample set.”

105. On information and belief, Defendant Intel’s accused products and software, through their optimization, development, sale, and operation, embody a computer-implemented method for predicting patterns in biological data, wherein the data comprises a large set of features that describe the data and a sample set from which the biological data is obtained is much smaller than the large set of features. Reasonable discovery will confirm this interpretation. As evidence, and for example, one such computer-implemented method from the bioinformatics community was conducted by Intel engineers on a liver patient dataset to predict whether a person has liver disease (hereinafter “*liver patient dataset*”). <https://software.intel.com/content/www/us/en/develop/articles/liver-patient-dataset-classification-using-the-intel-distribution-for-python.html> at page 1 (published May 3, 2018). As an additional example, one such computer-implemented method from the

financial metrics community was conducted by Intel engineers on a credit risk dataset to predict whether a person is a good credit risk or not (hereinafter “*credit risk dataset*”) (published April 20, 2018).

“Using the advantage of optimized scikit-learn* (Scikit-learn with Intel DAAL) that comes with Intel® Distribution for Python, we were able to achieve good results for the prediction problem.”

Source:< <https://software.intel.com/content/www/us/en/develop/articles/credit-risk-classification-faster-machine-learning-with-intel-optimized-packages.html>> p.1

“Using Intel optimized performance libraries in Intel® Xeon® Gold 6128 processor helped machine-learning applications to make predictions faster.”

Source:< <https://software.intel.com/content/www/us/en/develop/articles/credit-risk-classification-faster-machine-learning-with-intel-optimized-packages.html>> p.10

106. On information and belief, Defendant Intel’s accused products and software, through their optimization, development, sale, and operation, embody a computer-implemented method for identifying a determinative subset of features that are most correlated to the patterns. Reasonable discovery will confirm this interpretation. As evidence, and for example, Intel used the *liver patient dataset* comprising a plurality of features (*e.g.*, ten), and two classes (*e.g.*, liver patient or not) as shown in Table 2 below:

Liver Patient Dataset

Table 2. Dataset description.

Attribute Name	Attribute Description
V1	Age of the patient. Any patient whose age exceeded 89 is listed as being age 90.
V2	Gender of the patient
V3	Total bilirubin
V4	Direct bilirubin
V5	Alkphos alkaline phosphatase
V6	Sgpt alanine aminotransferase
V7	Sgot aspartate aminotransferase
V8	Total proteins
V9	Albumin
V10	A/G ratio albumin and globulin ratio
Class	Liver patient or not

Source:< <https://software.intel.com/content/www/us/en/develop/articles/liver-patient-dataset-classification-using-the-intel-distribution-for-python.html> > p.2

Feature selection is used to identify the most important features in the dataset that can build the model from the dataset.

“Feature selection is mainly applied to large datasets to reduce high dimensionality. This helps to identify the most important features in the dataset that can be given for model building.”

Source:< <https://software.intel.com/content/www/us/en/develop/articles/liver-patient-dataset-classification-using-the-intel-distribution-for-python.html> > p.4

In the *liver patient dataset* example described by Intel engineers, they used the random forest algorithm (a classifier) in order to visualize feature importance. However, as shown in the graphical data below for the receiver operating characteristics (ROC), additional classifiers were used on the *liver patient dataset*, including a support vector machine (SVM).

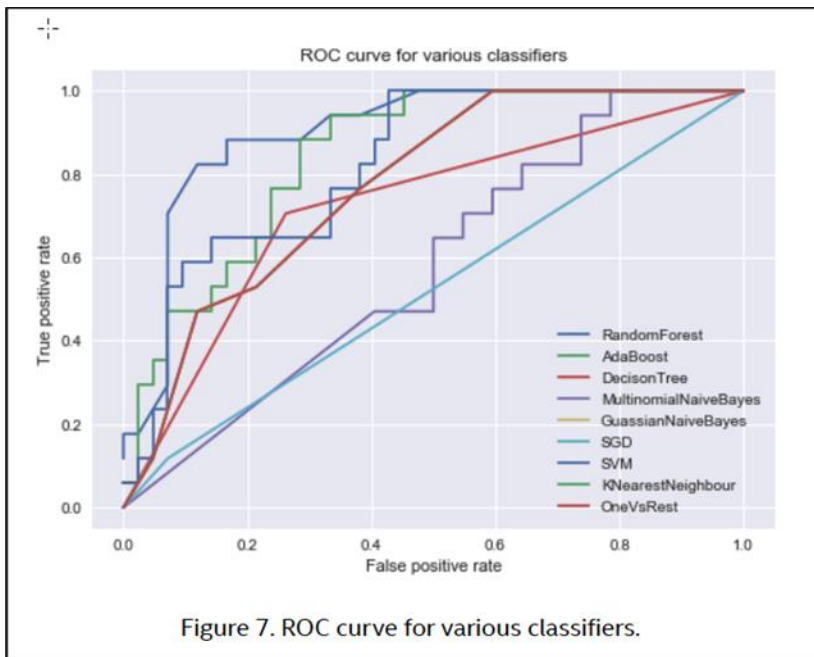

Source: <https://software.intel.com/content/www/us/en/develop/articles/liver-patient-dataset-classification-using-the-intel-distribution-for-python.html> at p.4

For the *credit risk dataset*, Intel’s classification comprised a plurality of features (*e.g.*, 21), and two classes (*e.g.*, good credit or bad credit) as shown in Table 3 below:

Credit Risk Dataset

Table 3. Dataset Description.

Attribute Name	Attribute Description
checking_status	Status of existing checking account, in Deutsche Marks (DM)
duration	Duration in months
credit_history	Credit history (credits taken, paid back duly, delays, critical accounts)
purpose	Purpose of the credit (car, television, etc.)
credit_amount	Credit loan amount, in Deutsche Marks (DM)
savings_status	Status of savings account and bonds, in Deutsche Marks
employment	Present employment, in number of years
installment_commitment	Installment rate in percentage of disposable income
personal_status	Personal status (married, single, etc.) and sex
other_parties	Other debtors and guarantors
residence_since	Present residence since X years
property_magnitude	Property (e.g., real estate)
age	Age in years
other_payment_plans	Other installment plans (banks, stores, etc.)
housing	Housing (rent, own)
existing_credits	Number of existing credits at this bank
job	Job
num_dependents	Number of people being liable to provide maintenance for
own_telephone	Telephone (yes and no)
foreign_worker	Foreign worker (yes and no)
class	Good credit or bad credit

Source: <https://software.intel.com/content/www/us/en/develop/articles/credit-risk-classification-faster-machine-learning-with-intel-optimized-packages.html> at p.2-3

As shown in the graph below for the receiver operating characteristics (ROC), one of the support vector classifiers for the *credit risk dataset* is a support vector machine (SVM).

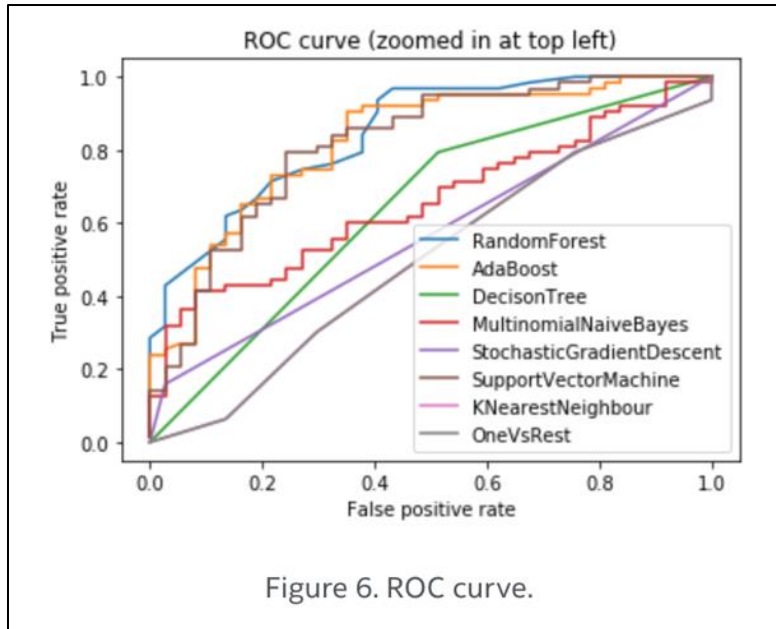

Source: <https://software.intel.com/content/www/us/en/develop/articles/credit-risk-classification-faster-machine-learning-with-intel-optimized-packages.html> at p.9

107. On information and belief, Defendant Intel's accused products and software, through their optimization, development, sale, and operation, embody a computer-implemented method for (a) inputting the data into a computer processor programmed for executing support vector machine classifiers. Reasonable discovery will confirm this interpretation. *See* ¶ 106 for additional information.

108. On information and belief, Defendant Intel's accused products and software, through their optimization, development, sale, and operation, embody a computer-implemented method for (b) training a support vector machine classifier with a training data set comprising at least a portion of the sample set and having known outcomes with respect to the patterns, wherein the classifier comprises weights having weight values that correspond to the features in the data set and removal of a subset of features affects the weight values. Reasonable discovery will confirm this interpretation. For example, and on information and belief, Intel optimizes the plurality of weights and determines the relative importance of the features within their processors, FPGAs, SoCs, and/or software using

Scikit-Learn (a machine learning library) function – ExtraTreesClassifier(). While Intel may have used this function in relation to an alternate feature selection algorithm, as shown above Intel has used up to eight other classifiers including SVM while conducting the *liver patient dataset* analysis.

“The ExtraTreesClassifier() function from the sklearn.ensemble package is used for calculation.”

Source: < <https://software.intel.com/content/www/us/en/develop/articles/liver-patient-dataset-classification-using-the-intel-distribution-for-python.html> > p.4

In the *liver patient dataset* method, 90% of the dataset was used to train the model, and 10% was used for testing/predicting the model outcomes. Another scikit-learn (a machine learning library) function was used to split the training and test data – StratifiedShuffleSplit.

“A part of the whole dataset was given for training the model and the rest was given for testing. In this experiment, 90 percent of the data was given for training and 10 percent for testing. Since StratifiedShuffleSplit (a function in scikit-learn) was applied to split the train-test data, the percentage of samples for each class was preserved, that is, in this case, 90 percent of samples from each class was taken for training and the remaining 10 percent from each class was given for testing. Classifiers from the scikit-learn package were used for model building.”

Source: < <https://software.intel.com/content/www/us/en/develop/articles/liver-patient-dataset-classification-using-the-intel-distribution-for-python.html> > p.5

For the *credit risk dataset* example, and on information and belief, the method included optimizing the plurality of weights and determining the relative importance of the features is calculated using scikit-learn.

“Classifier is implemented using two packages: scikit-learn with Intel DAAL and PyDAAL.”

Source: < <https://software.intel.com/content/www/us/en/develop/articles/credit-risk-classification-faster-machine-learning-with-intel-optimized-packages.html> > p.7

In the *credit risk dataset* method, 90% of the dataset was used to train the model, and 10% was used for testing/predicting the model outcomes.

“Data Split

Splitting the train and test data: The data is then split into train and test sets for further analysis. 90% of the data is used for training and 10% is for testing. The `train_test_split` function in `scikit-learn` is used for data splitting.”

Source: <<https://software.intel.com/content/www/us/en/develop/articles/credit-risk-classification-faster-machine-learning-with-intel-optimized-packages.html>> p.7

109. On information and belief, Defendant Intel’s accused products and software, through their optimization, development, sale, and operation, embody a computer-implemented method for (c) ranking the features according to their corresponding weight values. Reasonable discovery will confirm this interpretation. As evidence, and for the *liver patient dataset* example, the rankings were computed and plotted on the graph shown in Figure 5 below, showing the relative importance of the features. Note, while Intel may have used the forest of trees algorithm for feature importance, as shown above Intel has used up to eight other classifiers including SVM during the *liver patient dataset* analysis.

Liver Patient Dataset

“Figure 5 shows the feature importance with forests of trees. From the figure, it is clear that the most important feature is V5 (alkphos alkaline phosphatase) and the least important is V2 (gender).”

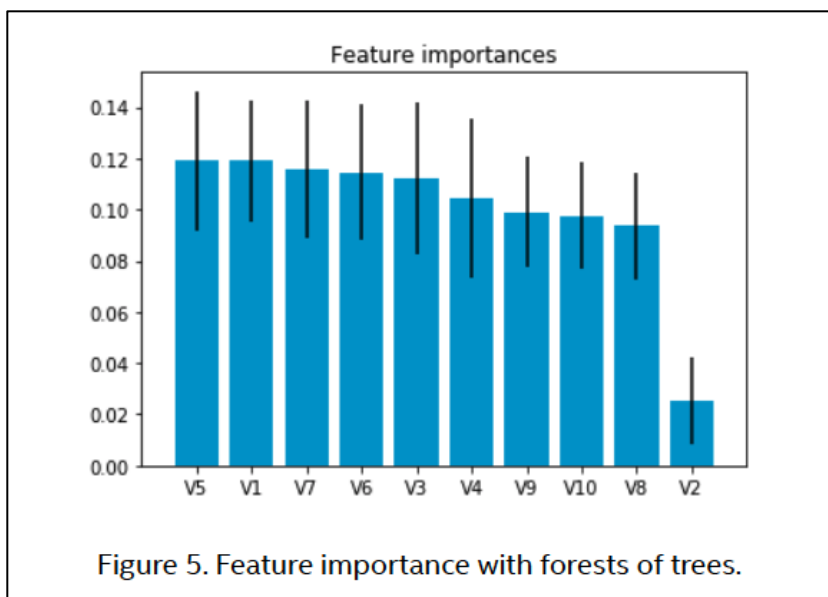

Source: <https://software.intel.com/content/www/us/en/develop/articles/liver-patient-dataset-classification-using-the-intel-distribution-for-python.html> at p.4

For the *credit risk dataset* example, the rankings were computed and plotted on the graph shown in Table 5 below, showing the relative importance of the features.

Credit Risk Dataset

Table 5. Feature Importance.

Feature	Score
credit_amount	0.1724
duration	0.1122
age	0.1057
purpose	0.0634
checking_status_no checking	0.0423
installment_commitment	0.0341
plan_none	0.0309
employment_4<=X<7	0.0293
residence_since	0.0260
credit_history_all paid	0.0244

Source: <https://software.intel.com/content/www/us/en/develop/articles/credit-risk-classification-faster-machine-learning-with-intel-optimized-packages.html> at p.4

110. On information and belief, Defendant Intel’s accused products and software, through their optimization, development, sale, and operation, embody a computer-implemented method for (d) removing one or more features corresponding to the smallest weight values. Reasonable discovery will confirm this interpretation. As evidence, and for *liver patient dataset* example, features with the smallest ranking criteria were made available to be eliminated, in this case it was V2 (gender of the patient), V8 (total proteins), V10 (A/G ratio albumin and globulin ratio), and V9 (albumin).

“Removing the least significant features help to reduce the processing time without significantly affecting the accuracy of the model. Here V2 (gender of the patient), V8 (total proteins), V10 (A/G ratio albumin and globulin ratio), and V9 (albumin) are dropped in order to reduce the number of features for model building.”

Source: <https://software.intel.com/content/www/us/en/develop/articles/liver-patient-dataset-classification-using-the-intel-distribution-for-python.html> at p.4

The *credit risk dataset* example also used such a ranking criterion.

Feature Selection

“Datasets may contain irrelevant or redundant features that might make the machine-learning model more complicated. **In this step, we aim to remove the irrelevant features which may cause an increase in run time, generate complex patterns, etc.**”

Source: <https://software.intel.com/content/www/us/en/develop/articles/credit-risk-classification-faster-machine-learning-with-intel-optimized-packages.html> at p.6 (emphasis added)

On information and belief, Defendant Intel’s accused products and software, through their optimization, development, sale, and operation, embody a computer-implemented method for (e) training a new classifier with the remaining features. Reasonable discovery will confirm this interpretation. On information and belief, in the *liver patient dataset* example, Intel engineers used the random forest algorithm (a classifier) to visualize feature

importance. However, as shown in the graphical data below for the receiver operating characteristics (ROC), additional classifiers were used on the *liver patient dataset*, including a support vector machine (SVM). It is reasonable that Intel trained each new classifier (*e.g.*, AdaBoost, DecisionTree, etc.), which included SVM, with the remaining features from the original random forest visualization.

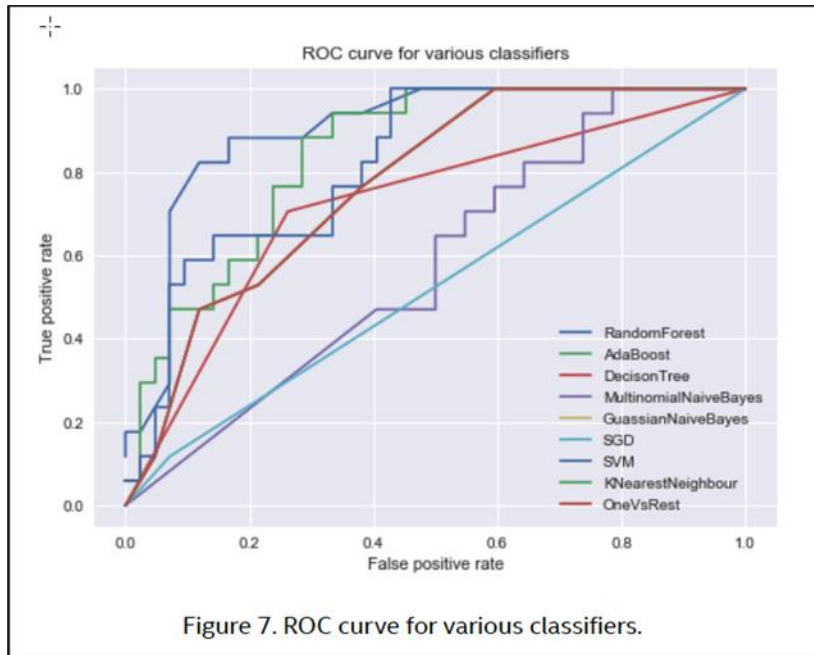

Source: <https://software.intel.com/content/www/us/en/develop/articles/liver-patient-dataset-classification-using-the-intel-distribution-for-python.html> at p.4

As with the liver patient dataset, the graph for the *credit risk dataset*, shows that Intel engineers used multiple classifiers, including SVM. It is reasonable that Intel trained each new classifier (*e.g.*, AdaBoost, DecisionTree, etc.), which included SVM, with the remaining features.

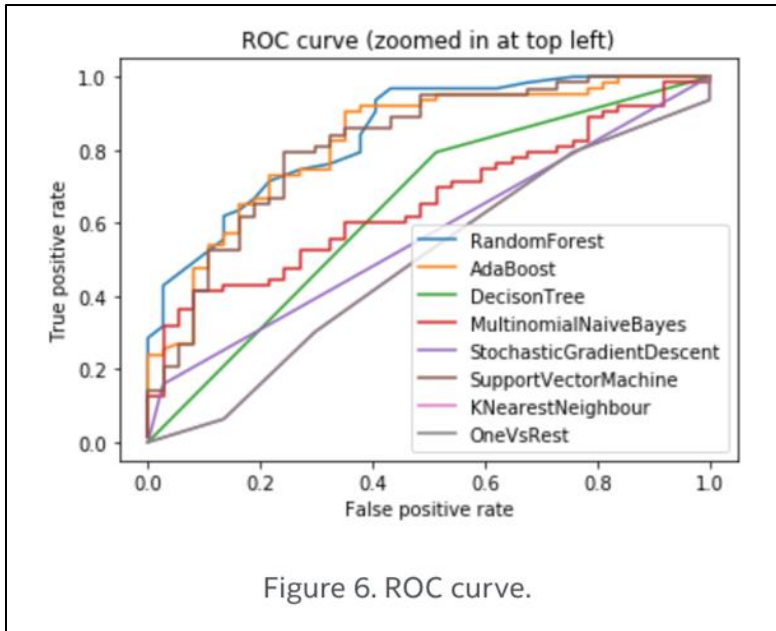

Source: <https://software.intel.com/content/www/us/en/develop/articles/credit-risk-classification-faster-machine-learning-with-intel-optimized-packages.html> at p.9

111. On information and belief, Defendant Intel’s accused products and software, through their optimization, development, sale, and operation, embody a computer-implemented method for (f) repeating steps (c) through (e) for a plurality of iterations until a final subset having a pre-determined number of features remains. Reasonable discovery will confirm this interpretation. On information and belief, and for example, the process of computing ranking criteria and eliminating the features with smaller ranking criteria, can be continued until the desired subset of features remains. In the *liver patient dataset*, there were four smaller ranking features, which could have been eliminated in one round, or several rounds of ranking and eliminating, depending on the engineer’s desired protocol.

“Removing the least significant features help to reduce the processing time without significantly affecting the accuracy of the model. Here V2 (gender of the patient), V8 (total proteins), V10 (A/G ratio albumin and globulin ratio), and V9 (albumin) are dropped in order to reduce the number of features for model building.”

Source: <https://software.intel.com/content/www/us/en/develop/articles/liver-patient-dataset-classification-using-the-intel-distribution-for-python.html> at p.4

Similar to the *liver patient dataset* example, and on information and belief, during the *credit risk dataset*, computing ranking criteria and eliminating the features with smaller ranking criteria, can be continued until the desired subset of features remains. For the *credit risk dataset*, when the irrelevant features were removed, the classifier performance improved slightly, but there was a significant improvement in run time, due to the reduced feature set.

“There was only a slight improvement in classifier performance when the **irrelevant features were removed**, but there was a significant improvement in run time.”

Source: <https://software.intel.com/content/www/us/en/develop/articles/credit-risk-classification-faster-machine-learning-with-intel-optimized-packages.html> at p.9 (emphasis added)

112. On information and belief, Defendant Intel’s accused products and software, through their optimization, development, sale, and operation, embody a computer-implemented method for generating at a printer or display device a report comprising a listing of the features in the final subset, wherein the final subset comprises the determinative subset of features for determining biological characteristics of the sample set. Reasonable discovery will confirm this interpretation. As evidence, and for the *liver patient dataset* example, the figure below illustrates the receiver operating characteristic (ROC), of the various classifiers. The ROC curve is created by plotting the true positive rate against the false positive rate at various threshold settings. As shown in the graph below for the receiver operating characteristics (ROC), one of the support vector classifiers for the *liver patient dataset* is a support vector machine (SVM).

Liver Patient Dataset

“The ROC curves for various classifiers are given in figure 7. The classifier output quality of different classifiers can be evaluated using this.”

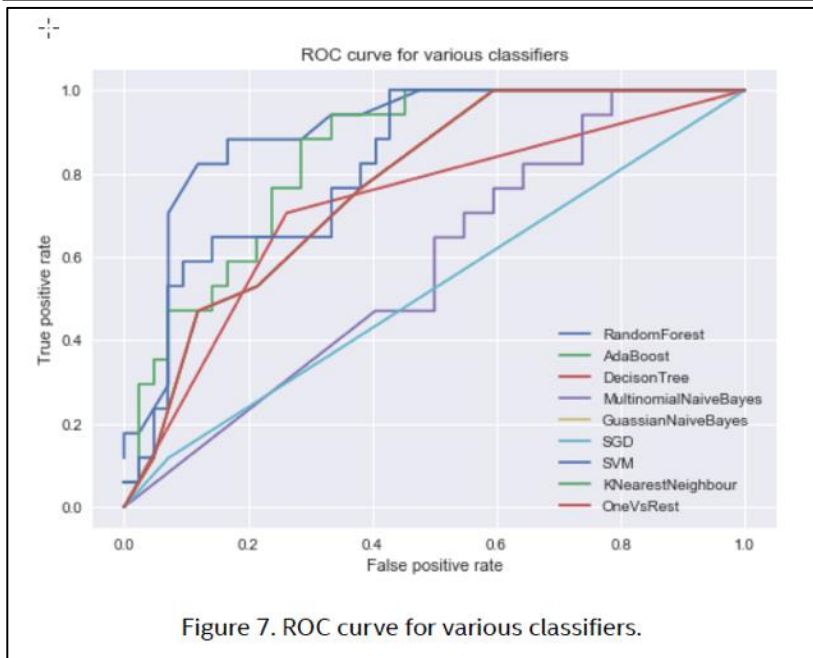

Source:< <https://software.intel.com/content/www/us/en/develop/articles/liver-patient-dataset-classification-using-the-intel-distribution-for-python.html> > p.8

For the *credit risk dataset* example, the figure below illustrates the receiver operating characteristic (ROC), of the various classifiers. The ROC curve is created by plotting the true positive rate against the false positive rate at various threshold settings. One of those classifiers for the *credit risk dataset* is a Support Vector Machine (SVM).

Credit Risk Dataset

“Figure 6 shows the ROC curve for classifiers in scikit-learn with Intel® DAAL. ROC curve demonstrates that Random Forest Classifier and Ada Boost classifier are the best classifiers.”

Source: <https://software.intel.com/content/www/us/en/develop/articles/credit-risk-classification-faster-machine-learning-with-intel-optimized-packages.html> at p.9

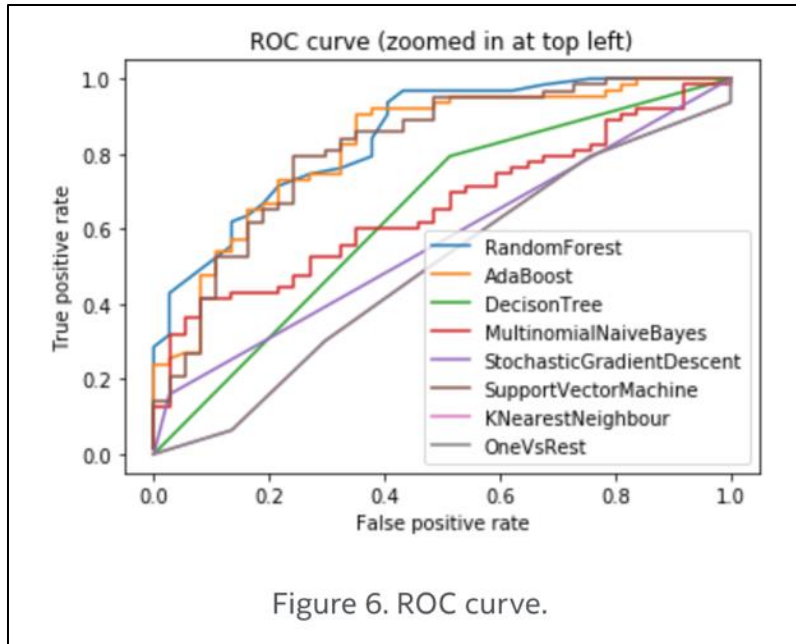

Source: <https://software.intel.com/content/www/us/en/develop/articles/credit-risk-classification-faster-machine-learning-with-intel-optimized-packages.html> at p.9

113. On information and belief, Defendant Intel performs each limitation of claim 12 of the '959 patent:

“12. A computer program product embodied on a computer readable medium for predicting patterns in data without overfitting by identifying a determinative subset of features that are most correlated to the patterns, wherein the data comprises a large set of features that describe the data, the computer program product comprising instructions for executing support vector machine classifiers and further for causing a computer processor to:

- (a) receive the data;
- (b) train a support vector machine classifier with a training data set having known outcomes with respect to the patterns, wherein the training data set has a number of training patterns that is much smaller than the number of features in the large set of features, and wherein the classifier comprises weights having weight values that correspond to the features in the data set and removal of a subset of features affects the weight values;
- (c) rank the features according to their corresponding weight values;
- (d) remove one or more features corresponding to the smallest weight values;
- (e) train a new classifier with the remaining features;
- (f) repeat steps (c) through (e) for a plurality of iterations until a final subset having a pre-determined number of features remains; and
- (g) generate at a printer or display device a report comprising a listing of the features in the final subset, wherein the final subset comprises the determinative subset of features.”

114. As shown in paragraph 113, independent claim 12 is directed to a computer program product for generating a ranked list of determinative features for the dataset. Claim 12 is of similar content and scope to claim 1, with respect to the basic weighing, ranking and eliminating steps of an RFE method. Claim 12 further includes accounting for the issue of predicting patterns in data without overfitting, the issue being resolved by carrying out the steps of the RFE method to generate the ranked list of determinative features. Accordingly, the direct infringement allegations of ¶¶ 105-112 are incorporated by reference herein and apply to claim 12. Defendant Intel's accused products and software perform and infringe each limitation of claim 12.

115. On information and belief, Defendant Intel performs each limitation of claim 16 of the '959 patent:

“16. An apparatus comprising:

a computer processor;

a memory;

a computer readable medium storing a computer program product for predicting patterns in data without overfitting by identifying a determinative subset of features that are most correlated to the patterns, wherein the data comprises a large set of features that describe the data, the computer program product comprising instructions for executing support vector machine classifiers and further for causing a computer processor to:

(a) receive the data;

(b) train a support vector machine classifier with a training data set having known outcomes with respect to the patterns, wherein the training data set has a number of training patterns that is much smaller than the number of features in the large set of features, and wherein the classifier comprises weights having weight values that correspond to the features in the data set and removal of a subset of features affects the weight values;

(c) rank the features according to their corresponding weight values;

(d) remove one or more features corresponding to the smallest weight values;

(e) train a new classifier with the remaining features;

(f) repeat steps (c) through (e) for a plurality of iterations until a final subset having a pre-determined number of features remains; and

(g) generate at a printer or display device a report comprising a listing of the features in the final subset, wherein the final subset comprises the determinative subset of features.”

116. As shown in paragraph 115, Independent claim 16 is directed to an apparatus claim for generating a ranked list of determinative features for the dataset. Claim 16 is of similar content and scope to claim 1 and claim 12, with respect to the basic weighing, ranking and eliminating steps of an RFE method. Like claim 12, claim 16 further includes accounting for the issue of predicting patterns in data without overfitting, the issue being resolved by carrying out the steps of the RFE method to generate the ranked list of determinative features. Claim 16 includes apparatus features of a processor, a memory and a computer-readable medium for storing a computer program product. Clearly Intel provides all three of these apparatus elements, as evidence by reference to ¶¶ 52-53. Accordingly, the direct infringement allegations of ¶¶ 105-112 are incorporated by reference herein and apply to claim 16. Defendant Intel's accused products and software perform and infringe each limitation of claim 16.

117. On information and belief, Defendant Intel's accused products and software embody each limitation of the dependent claims 2-11, 13-15 and 17-19 of the '959 patent. Reasonable discovery will confirm this interpretation and confirm exactly which Intel products implement and use (in testing, validating, verifying, optimizing, operating, etc.) HDC's patented SVM-RFE machine-learning algorithm.

Defendant's Direct Infringement of the Method Claims

118. Defendant performs the methods recited in claims 1-11 of the '959 patent. Infringement of a method claim requires performing every step of the claimed method. Defendant performs every step of the methods recited in claims 1-11. As set forth above, Defendant performs, for example, the method recited in claim 1, *i.e.*, a computer-implemented method for predicting patterns in biological data, wherein the data comprises a large set of features that describe the data and a sample set from which the biological

data is obtained is much smaller than the large set of features, the method comprising: identifying a determinative subset of features that are most correlated to the patterns comprising: (a) inputting the data into a computer processor programmed for executing support vector machine classifiers; (b) training a support vector machine classifier with a training data set comprising at least a portion of the sample set and having known outcomes with respect to the patterns, wherein the classifier comprises weights having weight values that correspond to the features in the data set and removal of a subset of features affects the weight values; (c) ranking the features according to their corresponding weight values; (d) removing one or more features corresponding to the smallest weight values; (e) training a new classifier with the remaining features; (f) repeating steps (c) through (e) for a plurality of iterations until a final subset having a pre-determined number of features remains; and generating at a printer or display device a report comprising a listing of the features in the final subset, wherein the final subset comprises the determinative subset of features for determining biological characteristics of the sample set.

119. Even if one or more steps recited in method claims 1-11 of the '959 patent are performed on technologies, computers, workstations, network-computer architectures, cloud-based architectures, etc., not in the physical possession of the Defendant (*e.g.*, in the possession of Intel partners, resellers, end-users, etc.), the claimed methods are specifically performed by Intel's processors, FPGAs, SoCs, and/or software. Defendant directly infringes as its processors, FPGAs, SoCs, and/or software dictate the performance of the claimed steps, such as the "identifying," "inputting," "training," "ranking," "removing" "training," "repeating," and "generating" steps recited in claim 1 of the '959

patent. Defendant's processors, FPGAs, SoCs, and/or software are designed and built by Defendant to perform the claimed steps automatically. Such processors, FPGAs, SoCs, and/or software predict and identify patterns in data. On information and belief, only Defendant can modify the functionality relating to these activities; no one else can modify such functionality. Defendant therefore performs all of the claimed steps and directly infringe the asserted method claims of the '959 patent.

120. *Additionally or alternatively*, to the extent third parties or end-users perform one or more steps of the methods recited in claims 1-11 of the '959 patent, any such action by third parties or end-users is attributable to Defendant, such that Defendant is liable for directly infringing such claims in a multiple actor or joint infringement situation, because Defendant directs or controls the other actor(s). In this regard, Defendant conditions participation in activities, as well as the receipt of benefits, upon performance of any such step by any such third party or end-user. Defendant exercises control over the methods performed by its processors, FPGAs, SoCs, and/or software, and benefit from others' use, including without limitation creating and receiving ongoing revenue streams from the accused products and related goods, and improvement/enhancement of its processors, FPGAs, SoCs, and/or software. End-users and third parties receive a benefit from fiscal gains (*e.g.*, third-party developers embedding Defendant's processors, FPGAs, SoCs, and/or software in their own products) and efficient and optimized data output – which forms the basis of entire businesses. Defendant also establishes the manner and timing of that performance by the third-party or end-user, as dictated by the claimed method steps. All third-party and end-user involvement, if any, is incidental, ancillary, or contractual.

121. Thus, to the extent that any step of the asserted method claims is performed by someone other than Defendant (*e.g.*, an end-user), Defendant nonetheless directly infringes the '959 patent at least by one or more of: (1) providing processors, FPGAs, SoCs, and/or software built and designed to perform methods covered by the asserted method claims; (2) dictating via software and associated directions and instructions (*e.g.*, to end-users) the use of the accused products such that, when used as built and designed by Defendant, such products perform the claimed methods; (3) having the ability to terminate others' access to and use of the accused products and related goods and services if the accused products are not used in accordance with Defendant's required terms; (4) marketing and advertising the accused products, and otherwise instructing and directing the use of the accused products in ways covered by the asserted method claims; and (5) updating and providing ongoing support and maintenance for the accused products.

**Defendant's Direct Infringement of the
Computer Program Product and Apparatus Claims**

122. Defendant makes, uses, sells, offers to sell, and/or imports the computer program products recited in claims 12-15 and the apparatuses recited in claims 16-19. Such claims are infringed when an accused product or apparatus, having every element of the claimed product or apparatus, is made, used, sold, offered for sale, or imported within the United States. Defendant makes, uses, sells, offers to sell, and/or imports the accused products (or cause such acts to be performed on its behalf), which possess every element recited in claims 12-15 and 16-19, as set forth in more detail above (with independent claims 12 and 16 as representative). Defendant therefore directly infringes the computer program product and apparatus claims of the '959 patent.

Induced Infringement

123. Defendant has induced and will continue to induce others' infringement of claims 1-19 of the '959 patent, in violation of 35 U.S.C. § 271(b). Defendant has actively encouraged infringement of the '959 patent, knowing that the acts it induced constituted infringement of the '959 patent, and its encouraging acts actually resulted in direct patent infringement by others.
124. As discussed above, Defendant had actual and constructive knowledge of the '959 patent, as well as actual and constructive knowledge of the relevance and significance of the '959 patent to its research and development, as well as its product offerings, at least no later than May 19, 2005 (per scholarly article), no later than December 5, 2006 (per family-to-family USPTO citation), and certainly no later than November 10, 2011 (per HDC direct correspondence).
125. To the extent Defendant do not specify and control the relevant algorithms and machine learning capabilities of the accused products in the claimed manner (which it does), Defendant—with full knowledge of the '959 patent and its relevance to Intel's product offerings—actively encourages others (*e.g.*, end-users and third parties such as professionals, businesses, developers, Intel partners, etc.)—to use the accused products as claimed. Such active encouragement by Defendant takes many forms, and includes promotional and instructional materials, as well as technical specifications and requirements, and ongoing technical assistance.
126. On information and belief, Defendant engaged in these acts with the actual intent to cause the acts which it knew or should have known would induce actual infringement,

or otherwise exercised willful blindness of a high probability that it has induced infringement.

Contributory Infringement

127. Defendant has contributed and will continue to contribute to others' infringement of claims 1-19 of the '959 patent, in violation of 35 U.S.C. § 271(c). Defendant has offered to sell and sold within the United States, or imported into the United States, material or apparatus for use in practicing the patented computer-implemented methods, claims 1-11, constituting a material part of the patented methods, knowing the same to be especially made or especially adapted for use in infringing the '959 patent, and not a staple article or commodity of commerce for substantial non-infringing use. Defendant has offered to sell and sold within the United States, or imported into the United States, at least some of the components of the claimed computer program products and apparatuses, claims 12-15 and 16-19 respectively, constituting a material part of the patented computer program products and apparatuses, knowing the same to be especially made or especially adapted for use in infringing the '959 patent, and not a staple article or commodity of commerce for substantial non-infringing use.

128. As discussed above, Defendant had actual and constructive knowledge of the '959 patent, as well as actual and constructive knowledge of the relevance and significance of the '959 patent to its research and development, as well as its product offerings, at least no later than May 19, 2005 (per scholarly article), no later than December 5, 2006 (per family-to-family USPTO citation), and certainly no later than November 10, 2011 (per HDC direct correspondence).

129. To the extent Defendant do not specify and control the relevant algorithms and machine learning capabilities of the accused products in the claimed manner (which it does), Defendant supplies the accused products to others (*e.g.*, end-users and third parties) that perform the claimed data pattern identification and optimization, and/or that, when combined with other components, constitute the claimed computer implemented methods. The accused products embody SVM-RFE processes, which constitute a material part of the claimed inventions, if not the entire claimed inventions themselves. Defendant dictates and controls the optimization and identification componentry and techniques in the accused products, with full knowledge of the '959 patent and its relevance to its research development, as well as its product offerings, and know the same to be especially made and especially adapted for the infringement of the '959 patent.

130. On information and belief, the portions of Defendant's products that identify patterns in data and implement SVM-RFE, including Intel branded products made, marketed, used, sold, offered to sell, or imported by Defendant, are not staple articles or commodities of commerce suitable for substantial non-infringing use.

Willful Infringement

131. As set forth above, Defendant had actual and constructive knowledge of the '959 patent, as well as actual and constructive knowledge of the relevance and significance of the '959 patent to its research and development, as well as its product offerings, at least no later than May 19, 2005 (per scholarly article), no later than December 5, 2006 (per family-to-family USPTO citation), and certainly no later than November 10, 2011 (per HDC direct correspondence).

132. Still further, as set forth in ¶¶ 30-31 *supra*, Plaintiff and Defendant were engaged in an Interference proceeding in the USPTO, that began on September 19, 2016 and ended in February 2019. On February 27, 2019, the USPTO ruled in favor of Health Discovery Corporation on the SVM-RFE Patent application, finding that Health Discovery Corporation was entitled to claim exclusive ownership rights to the SVM-RFE technology as set forth in the SVM-RFE Patent application that was filed to provoke the Interference. The decision ordered Intel Corporation's Patent No. 7,685,077 to be cancelled. The decision also dismissed Intel Corporation's motions challenging the validity of Health Discovery Corporation's pending claims and issued patents covering SVM-RFE. On September 3, 2019, the USPTO issued U.S. Patent No. 10,402,685 ("SVM-RFE Patent") (one of the Patents-in-Suit) for Health Discovery Corporation's patent application covering SVM-RFE methods.

133. Defendant therefore had continuing actual and constructive knowledge of HDC's SVM-RFE patent portfolio, which included the '959 patent, and the relevance and significance of the SVM-RFE portfolio to Intel's research and development.

134. Defendant's infringement, as demonstrated above, is egregious, and combined with Defendant's clear knowledge, has been willful. Plaintiff respectfully request that the Court award enhanced damages based on Defendant's conduct.

Damage to Health Discovery Corporation

135. On information and belief, Defendant's actions have and will continue to constitute direct and indirect (induced and contributory) infringement of at least claims 1-19 of the '959 patent in violation of 35 U.S.C. §271.

136. As a result of Defendant's infringement of at least claims 1-19 of the '959 patent, HDC has suffered monetary damages in an amount yet to be determined, in no event less than a reasonable royalty, and will continue to suffer damages in the future unless Defendant's infringing activities are enjoined by this Court.

137. Defendant's wrongful acts have damaged and will continue to damage HDC irreparably, and Plaintiff has no adequate remedy at law for those wrongs and injuries. In addition to its actual damages, Plaintiff HDC is entitled to a permanent injunction restraining and enjoining Defendant and its respective agents, servants, and employees, and all person acting thereunder, in concert with, or on its behalf, from infringing at least claims 1-19 of the '959 patent.

COUNT III
INFRINGEMENT OF THE '483 PATENT

138. Plaintiff HDC repeats and realleges the above paragraphs, which are incorporated by reference as if fully restated herein.

139. Plaintiff HDC is the owner by assignment of all right, title, and interest in the '483 patent, including all right to recover for any and all infringement thereof.

140. Defendant is not licensed or otherwise authorized to practice the '483 patent.

141. The '484 patent is valid and enforceable. In this regard, the '483 patent is presumed valid under 35 U.S.C. §282.

142. The '483 patent relates to, among other things, methods, computer program products, and non-transitory machine-readable mediums for using learning machines (*e.g.*, Support Vector Machines) to identify relevant patterns in datasets and select relevant features within the datasets to optimize data classification (*e.g.*, as Recursive Feature Elimination). The '483 patent invented such methods, products, and mediums, for

example, as automated knowledge discovery tools. The ‘483 invention is directed, for example, at biological systems to improve diagnosing and predicting *e.g.*, diseases; and testing and treating individuals with changes in their biological systems.

143. On information and belief, Defendant manufactures and markets infringing products. *See*, ¶¶ 52-54, *supra*. Such products infringe on the inventive aspects of the ‘483 patent and include, *inter alia*, Intel processors (*e.g.*, Intel Xeon series; etc.) and Intel Field Programmable Gate Arrays (FPGAs) and System on Chips (SoCs) (*e.g.*, Intel Agilex Series; Intel Stratix Series; etc.), and Intel software (*e.g.*, Intel Data Analytics Acceleration Library). Intel processors, FPGAs, SoCs, and software are deployed in Intel/Intel-partnered computers, workstations, network-computer architectures, and cloud-based architectures. Intel uses machine learning software programs in-house to test, validate, verify and optimize their processors and conduct comparative studies, and these machine learning software programs employ SVM-RFE methods claimed in HDC’s ‘483 patent.

144. The ‘483 patent is well-known in the SVM-RFE industry. It has been cited in at least eleven (11) U.S. patents and patent applications, including patents and patent applications filed by industry leaders, such as Honeywell International Inc. and Qualcomm Incorporated.

145. The ‘483 patent was cited in at least one Intel Corporation patent via family-to-family citations, including:

- a. U.S. Patent No. 8,108,324, “Forward Feature Selection for Support Vector Machines,” with a publication date of January 31, 2012.

146. The '483 patent was cited in at least 1 Intel Corporation scholarly article written by 9 Intel employees, which included the two named inventors of Intel's SVM-RFE U.S. Patent No. 7,685,077, which was the subject of the Interference Proceeding in the USPTO:

- a. Y. Chen, et al., "Performance Scalability of Data-Mining Workloads in Bioinformatics," *Intel Technology Journal*, Vol. 9, No. 2, May 19, 2005. **Exhibit I.**

147. Moreover, Plaintiff HDC began corresponding with Defendant about the SVM-RFE patents, including the '483 patent (which was pending at the time), in November 2011. Specifically, HDC sent a letter to Steven Rodgers on November 10, 2011, advising of a reexamination of Intel Patent No. 7,685,077, and a filing to provoke an interference with the '077 patent. On information and belief, Steven Rodgers was Intel's Vice President of Legal and Corporate Affairs in November 2011. At the time of this filing, Rodgers is now Executive Vice President and General Counsel for Intel.

148. Therefore, Defendant had actual and constructive knowledge of the '483 patent, as well as actual and constructive knowledge of the relevance and significance of the '483 patent to its research and development, as well as its product offerings, at least no later than May 19, 2005 (per scholarly article), no later than November 10, 2011 (per HDC direct correspondence), and certainly no later than January 31, 2012 (per family-to-family USPTO citation).

Defendant's Direct Infringement of the '483 Patent

149. On information and belief, in violation of 35 U.S.C. § 271(a), Defendant has directly infringed, continues to directly infringe, and will continue to directly infringe absent the Court's intervention one or more claims of the '483 patent, including for

example (but not limited to) at least computer-implemented method claims 1-6 and 22-31, computer program product claims 7-12, and non-transitory machine-readable medium claims 13-17, 18-21, and 32-38 of the '483 patent, either literally or under the doctrine of equivalents, by making, using, testing, selling, and/or offering to sell within the United States, or importing into the United States, without license or authority, Defendant's infringing products, including, but not limited to, at least Intel AI-optimizing/machine learning processors, FPGAs, SoCs, and/or software – which are, *inter alia*, deployed in Intel/Intel-partnered computers, workstations, network-computer architectures, and cloud-based architectures. Defendant's infringing products also include software applications or libraries that incorporate SVM-RFE algorithms, such as Intel's Data Analytics Acceleration Library (DAAL) that utilizes SVM-RFE algorithms contained in the scikit-learn open source software. The following products and software are representative, *see* paragraphs 52-54 *supra*, of Intel's infringement.

Direct Infringement Allegations

150. On information and belief, Intel's infringing products contain substantially similar componentry and functionality at least insofar as the claimed inventions are concerned. The allegations below illustrate how Intel's infringing products (*e.g.*, processors, FPGAs, SoCs, and Software) embody the claimed computer-implemented methods, computer program products, and non-transitory machine-readable mediums. Such infringement by these products is exemplified through the independent claims of the '483 patent, which represent the scope of Intel's infringement.

151. As Defendant Intel is in the sole and complete possession of its relevant source code, algorithms, etc., with such information not publicly available, Plaintiff HDC

respectfully requests early, limited discovery to confirm which Intel products and uses by Intel infringe. *See* ¶ 56.

152. Plaintiff HDC is requesting early discovery to confirm exactly which Intel products or uses of the SVM-RFE invention infringe the ‘483 patent. Due to the nature of Intel’s business, the information required to determine exactly which Intel products or uses infringe is, in large part, not publicly available. However, although said information is not publicly available, Intel has publicly admitted (on several occasions) that it uses/used SVM-RFE in the development and optimization of its products (software, hardware, packages, libraries, etc.). HDC did not authorize Intel’s use of SVM-RFE, for any reason, and therefore Intel’s admissions of using SVM-RFE makes it highly probable that Intel is infringing the ‘483 patent. Intel may also be using the SVM-RFE technology, but referring to it by a different name to conceal infringing activities. The following citations, *inter alia*, include examples of Intel’s admissions in the past, and there is no reason to believe they have ceased using the invention. *Supra* ¶ 35 for additional publications.

- a. A. Jaleel, et al., “Last Level Cache (LLC) Performance in Data Mining Workloads on a CMP – A Case Study of Parallel Bioinformatics Workloads,” *Proc. of the 12th Int’l Symp. on High Performance Computer Architecture (HPCA)*, 2006. [2 of 3 authors were Intel employees]. **Exhibit N.**
- b. Y. Chen, et al., “Performance Scalability of Data-Mining Workloads in Bioinformatics,” *Intel Technology Journal*, Vol. 9, No. 2, May 19, 2005. [9 of 9 authors were Intel employees, including the two named inventors of Intel SVM-RFE patent US7,685,077]. **Exhibit I.**

- c. U. Srinivasan, et al., “Characterization and Analysis of HMMER and SVM-RFE Parallel Bioinformatics Applications,” *Proc. of the IEEE Int’l Symp. on Workload Characterization (IISWC)*, Oct. 2005. [8 of 8 authors were Intel employees; including the two named inventors of Intel SVM-RFE patent US7,685,077] [In endnote 7, authors attribute SVM-RFE to Guyon and Weston, two of the named inventors of the ‘483 patent]. **Exhibit J.**

153. On information and belief, Defendant Intel performs each limitation of claim 1 of the ‘483 patent:

1. A computer-implemented method comprising:

(a) inputting into a computer processor programmed to execute a support vector machine a set of training examples having known labels with regard to two or more classes, each training example described by a vector of feature values for a plurality of features, the support vector machine comprising a decision function having a plurality of weights, wherein each feature has a corresponding weight;

(b) training the support vector machine by optimizing the plurality of weights so that a cost function is minimized and support vectors comprising a subset of the training examples are defined, wherein the decision function is based on the support vectors;

(c) computing ranking criteria using the optimized plurality of weights, wherein the ranking criterion estimates for each feature the effect on the cost function of removing that feature, and wherein features having the smallest effect on the cost function have the smallest ranking criteria;

(d) eliminating one or more features corresponding to the smallest ranking criteria to yield a reduced set of features;

(e) repeating steps (c) through (d) for the reduced set of features for a plurality of iterations until a subset of features of predetermined size remains, wherein the subset of features comprises determinative features for separating the set of training examples into the two or more classes; and

(f) generating at a printer or display device an output comprising a listing of the determinative features.

154. On information and belief, Defendant Intel’s accused products and software, through their optimization, development, sale, and operation, embody a computer-implemented method patented by HDC. Reasonable discovery will confirm this interpretation. As evidence, and for example, one such computer-implemented method

from the bioinformatics community was conducted by Intel engineers on a liver patient dataset to predict whether a person has liver disease (hereinafter “*liver patient dataset*”). See <https://software.intel.com/content/www/us/en/develop/articles/liver-patient-dataset-classification-using-the-intel-distribution-for-python.html> at page 1 (published May 3, 2018). As an additional example, one such computer-implemented method from the financial metrics community was conducted by Intel engineers on a credit risk dataset to predict whether a person is a good credit risk or not (hereinafter “*credit risk dataset*”) (published April 20, 2018).

“Using the advantage of optimized scikit-learn* (Scikit-learn with Intel DAAL) that comes with Intel® Distribution for Python, we were able to achieve good results for the prediction problem.”

Source:< <https://software.intel.com/content/www/us/en/develop/articles/credit-risk-classification-faster-machine-learning-with-intel-optimized-packages.html>> p.1

“Using Intel optimized performance libraries in Intel® Xeon® Gold 6128 processor helped machine-learning applications to make predictions faster.”

Source:< <https://software.intel.com/content/www/us/en/develop/articles/credit-risk-classification-faster-machine-learning-with-intel-optimized-packages.html>> p.10

155. On information and belief, Defendant Intel’s accused products and software, through their optimization, development, sale, and operation, embody a computer-implemented method (a) inputting into a computer processor programmed to execute a support vector machine a set of training examples having known labels with regard to two or more classes, each training example described by a vector of feature values for a plurality of features, the support vector machine comprising a decision function having a plurality of weights, wherein each feature has a corresponding weight. Reasonable discovery will confirm this interpretation. As evidence, and for example, Intel used the

liver patient dataset comprising a plurality of features (e.g., ten), and two classes (e.g., liver patient or not) as shown in Table 2 below:

Liver Patient Dataset

Table 2. Dataset description.

Attribute Name	Attribute Description
V1	Age of the patient. Any patient whose age exceeded 89 is listed as being age 90.
V2	Gender of the patient
V3	Total bilirubin
V4	Direct bilirubin
V5	Alkphos alkaline phosphatase
V6	Sgpt alanine aminotransferase
V7	Sgot aspartate aminotransferase
V8	Total proteins
V9	Albumin
V10	A/G ratio albumin and globulin ratio
Class	Liver patient or not

Source:< <https://software.intel.com/content/www/us/en/develop/articles/liver-patient-dataset-classification-using-the-intel-distribution-for-python.html> > p.2

Feature selection is used to identify the most important features in the dataset that can build the model from the dataset.

“Feature selection is mainly applied to large datasets to reduce high dimensionality. This helps to identify the most important features in the dataset that can be given for model building.”

Source:< <https://software.intel.com/content/www/us/en/develop/articles/liver-patient-dataset-classification-using-the-intel-distribution-for-python.html> > p.4

In the *liver patient dataset* example described by Intel engineers, they used the random forest algorithm (a classifier) in order to visualize feature importance. However, as shown in the graphical data below for the receiver operating characteristics (ROC), additional classifiers were used on the *liver patient dataset*, including a support vector machine (SVM).

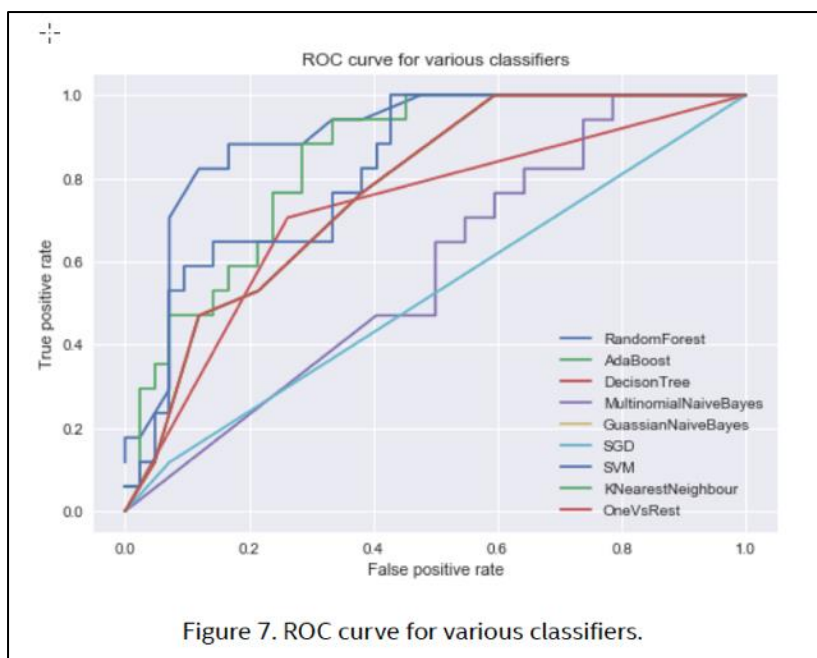

Source: <https://software.intel.com/content/www/us/en/develop/articles/liver-patient-dataset-classification-using-the-intel-distribution-for-python.html> at p.4

For the *credit risk dataset*, Intel's classification comprised a plurality of features (*e.g.*, 21), and two classes (*e.g.*, good credit or bad credit) as shown in Table 3 below:

Credit Risk Dataset

Table 3. Dataset Description.

Attribute Name	Attribute Description
checking_status	Status of existing checking account, in Deutsche Marks (DM)
duration	Duration in months
credit_history	Credit history (credits taken, paid back duly, delays, critical accounts)
purpose	Purpose of the credit (car, television, etc.)
credit_amount	Credit loan amount, in Deutsche Marks (DM)
savings_status	Status of savings account and bonds, in Deutsche Marks
employment	Present employment, in number of years
installment_commitment	Installment rate in percentage of disposable income
personal_status	Personal status (married, single, etc.) and sex
other_parties	Other debtors and guarantors
residence_since	Present residence since X years
property_magnitude	Property (e.g., real estate)
age	Age in years
other_payment_plans	Other installment plans (banks, stores, etc.)
housing	Housing (rent, own)
existing_credits	Number of existing credits at this bank
job	Job
num_dependents	Number of people being liable to provide maintenance for
own_telephone	Telephone (yes and no)
foreign_worker	Foreign worker (yes and no)
class	Good credit or bad credit

Source:< <https://software.intel.com/content/www/us/en/develop/articles/credit-risk-classification-faster-machine-learning-with-intel-optimized-packages.html>> p. 2-3

As shown in the graph below for the receiver operating characteristics (ROC), one of the support vector classifiers for the *credit risk dataset* is a support vector machine (SVM).

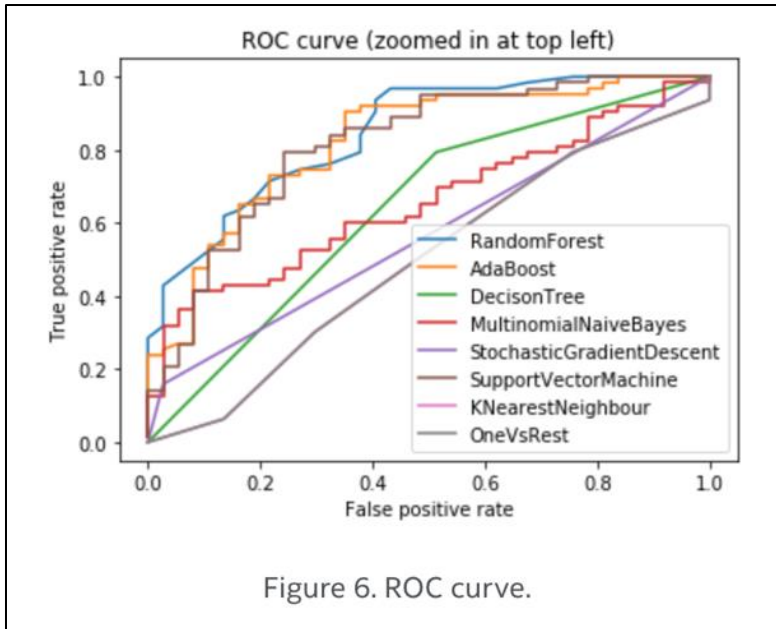

Source: <https://software.intel.com/content/www/us/en/develop/articles/credit-risk-classification-faster-machine-learning-with-intel-optimized-packages.html> at p.9

156. On information and belief, Defendant Intel's accused products and software, through their optimization, development, sale, and operation, embody a computer-implemented method (b) training the support vector machine by optimizing the plurality of weights so that a cost function is minimized and support vectors comprising a subset of the training examples are defined, wherein the decision function is based on the support vectors. Reasonable discovery will confirm this interpretation. For example, and on information and belief, Intel optimizes the plurality of weights and determines the relative importance of the features within their processors, FPGAs, SoCs, and/or software using Scikit-Learn (a machine learning library) function – `ExtraTreesClassifier()`. While Intel may have used this function in relation to an alternate feature selection algorithm, as shown above Intel has used up to eight other classifiers including SVM during the *liver patient dataset* analysis.

“The ExtraTreesClassifier() function from the sklearn.ensemble package is used for calculation.”

Source:< <https://software.intel.com/content/www/us/en/develop/articles/liver-patient-dataset-classification-using-the-intel-distribution-for-python.html> > p.4

In the *liver patient dataset* method, 90% of the dataset was used to train the model, and 10% was used for testing/predicting the model outcomes. Another scikit-learn (a machine learning library) function was used to split the training and test data – StratifiedShuffleSplit.

“A part of the whole dataset was given for training the model and the rest was given for testing. In this experiment, 90 percent of the data was given for training and 10 percent for testing. Since StratifiedShuffleSplit (a function in scikit-learn) was applied to split the train-test data, the percentage of samples for each class was preserved, that is, in this case, 90 percent of samples from each class was taken for training and the remaining 10 percent from each class was given for testing. Classifiers from the scikit-learn package were used for model building.”

Source:< <https://software.intel.com/content/www/us/en/develop/articles/liver-patient-dataset-classification-using-the-intel-distribution-for-python.html> > p.5

For the *credit risk dataset* example, and on information and belief, the method included optimizing the plurality of weights and determining the relative importance of the features is calculated using scikit-learn.

“Classifier is implemented using two packages: scikit-learn with Intel DAAL and PyDAAL.”

Source: <<https://software.intel.com/content/www/us/en/develop/articles/credit-risk-classification-faster-machine-learning-with-intel-optimized-packages.html>> p.7

In the *credit risk dataset* method, 90% of the dataset was used to train the model, and 10% was used for testing/predicting the model outcomes.

“Data Split

Splitting the train and test data: The data is then split into train and test sets for further analysis. 90% of the data is used for training and 10% is for testing. The train_test_split function in scikit-learn is used for data splitting.”

Source: <<https://software.intel.com/content/www/us/en/develop/articles/credit-risk-classification-faster-machine-learning-with-intel-optimized-packages.html>> p.7

157. On information and belief, Defendant Intel’s accused products and software, through their optimization, development, sale, and operation, embody a computer-implemented method (c) computing ranking criteria using the optimized plurality of weights, wherein the ranking criterion estimates for each feature the effect on the cost function of removing that feature, and wherein features having the smallest effect on the cost function have the smallest ranking criteria. Reasonable discovery will confirm this interpretation. As evidence, and for the *liver patient dataset* example, the rankings were computed and plotted on the graph shown in Figure 5 below, showing the relative importance of the features. Note, while Intel may have used the forest of trees algorithm for feature importance, as shown above Intel has used up to eight other classifiers including SVM during the *liver patient dataset* analysis.

Liver Patient Dataset

“Figure 5 shows the feature importance with forests of trees. From the figure, it is clear that the most important feature is V5 (alkphos alkaline phosphatase) and the least important is V2 (gender).”

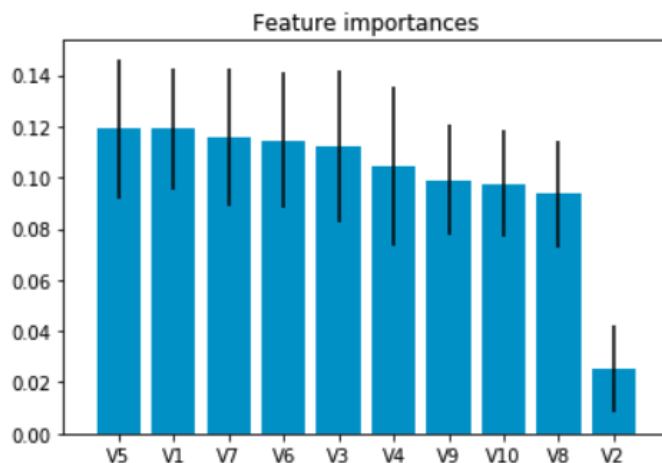

Figure 5. Feature importance with forests of trees.

Source:< <https://software.intel.com/content/www/us/en/develop/articles/liver-patient-dataset-classification-using-the-intel-distribution-for-python.html>> p.4

For the *credit risk dataset* example, the rankings were computed and plotted on the graph shown in Table 5 below, showing the relative importance of the features.

Credit Risk Dataset

Table 5. Feature Importance.

Feature	Score
credit_amount	0.1724
duration	0.1122
age	0.1057
purpose	0.0634
checking_status_no checking	0.0423
installment_commitment	0.0341
plan_none	0.0309
employment_4<=X<7	0.0293
residence_since	0.0260
credit_history_all paid	0.0244

Source: <https://software.intel.com/content/www/us/en/develop/articles/credit-risk-classification-faster-machine-learning-with-intel-optimized-packages.html> at p.4

158. On information and belief, Defendant Intel's accused products and software, through their optimization, development, sale, and operation, embody a computer-implemented method (d) eliminating one or more features corresponding to the smallest ranking criteria to yield a reduced set of features. Reasonable discovery will confirm this interpretation. As evidence, and for *liver patient dataset* example, features with the smallest ranking criteria were made available to be eliminated, in this case it was V2 (gender of the patient), V8 (total proteins), V10 (A/G ratio albumin and globulin ratio), and V9 (albumin).

“Removing the least significant features help to reduce the processing time without significantly affecting the accuracy of the model. Here V2 (gender of the patient), V8 (total proteins), V10 (A/G ratio albumin and globulin ratio), and V9 (albumin) are dropped in order to reduce the number of features for model building.”

Source: <https://software.intel.com/content/www/us/en/develop/articles/liver-patient-dataset-classification-using-the-intel-distribution-for-python.html> at p.4

The *credit risk dataset* example also used such a ranking criterion.

Feature Selection

“Datasets may contain irrelevant or redundant features that might make the machine-learning model more complicated. **In this step, we aim to remove the irrelevant features which may cause an increase in run time, generate complex patterns, etc.**”

Source: <https://software.intel.com/content/www/us/en/develop/articles/credit-risk-classification-faster-machine-learning-with-intel-optimized-packages.html> at p.6 (emphasis added)

159. On information and belief, Defendant Intel’s accused products and software, through their optimization, development, sale, and operation, embody a computer-implemented method (e) repeating steps (c) through (d) for the reduced set of features for a plurality of iterations until a subset of features of predetermined size remains, wherein the subset of features comprises determinative features for separating the set of training examples into the two or more classes. Reasonable discovery will confirm this interpretation. On information and belief, and for example, the process of computing ranking criteria and eliminating the features with smaller ranking criteria, can be continued until the desired subset of features remains. In the *liver patient dataset*, there were four smaller ranking features, which could have been eliminated in one round, or several rounds of ranking and eliminating, depending on the engineer’s desired protocol.

“Removing the least significant features help to reduce the processing time without significantly affecting the accuracy of the model. Here V2 (gender of the patient), V8 (total proteins), V10 (A/G ratio albumin and globulin ratio), and V9 (albumin) are dropped in order to reduce the number of features for model building.”

Source: <https://software.intel.com/content/www/us/en/develop/articles/liver-patient-dataset-classification-using-the-intel-distribution-for-python.html> at p.4

Similar to the *liver patient dataset* example, and on information and belief, during the *credit risk dataset*, computing ranking criteria and eliminating the features with smaller ranking criteria, can be continued until the desired subset of features remains. For the *credit risk dataset*, when the irrelevant features were removed, the classifier performance improved slightly, but there was a significant improvement in run time, due to the reduced feature set.

“There was only a slight improvement in classifier performance when the **irrelevant features were removed**, but there was a significant improvement in run time.”

Source: <https://software.intel.com/content/www/us/en/develop/articles/credit-risk-classification-faster-machine-learning-with-intel-optimized-packages.html> at p.9 (emphasis added)

160. On information and belief, Defendant Intel’s accused products and software, through their optimization, development, sale, and operation, embody a computer-implemented method (f) generating at a printer or display device an output comprising a listing of the determinative features. Reasonable discovery will confirm this interpretation. As evidence, and for the *liver patient dataset* example, the figure below illustrates the receiver operating characteristic (ROC), of the various classifiers. The ROC curve is created by plotting the true positive rate against the false positive rate at various threshold settings. As shown in the graph below for the receiver operating characteristics (ROC), one of the support vector classifiers for the *liver patient dataset* is a support vector machine (SVM).

Liver Patient Dataset

“The ROC curves for various classifiers are given in figure 7. The classifier output quality of different classifiers can be evaluated using this.”

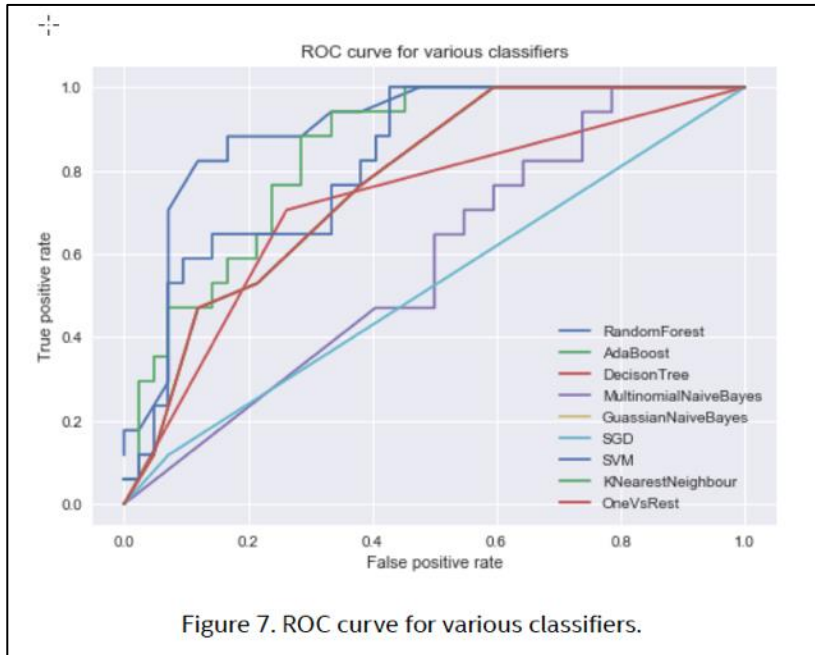

Source:< <https://software.intel.com/content/www/us/en/develop/articles/liver-patient-dataset-classification-using-the-intel-distribution-for-python.html>> p.8

For the *credit risk dataset* example, the figure below illustrates the receiver operating characteristic (ROC), of the various classifiers. The ROC curve is created by plotting the true positive rate against the false positive rate at various threshold settings. One of those classifiers for the *credit risk dataset* is a Support Vector Machine (SVM).

Credit Risk Dataset

“Figure 6 shows the ROC curve for classifiers in scikit-learn with Intel® DAAL. ROC curve demonstrates that Random Forest Classifier and Ada Boost classifier are the best classifiers.”

Source: <https://software.intel.com/content/www/us/en/develop/articles/credit-risk-classification-faster-machine-learning-with-intel-optimized-packages.html> at p.9

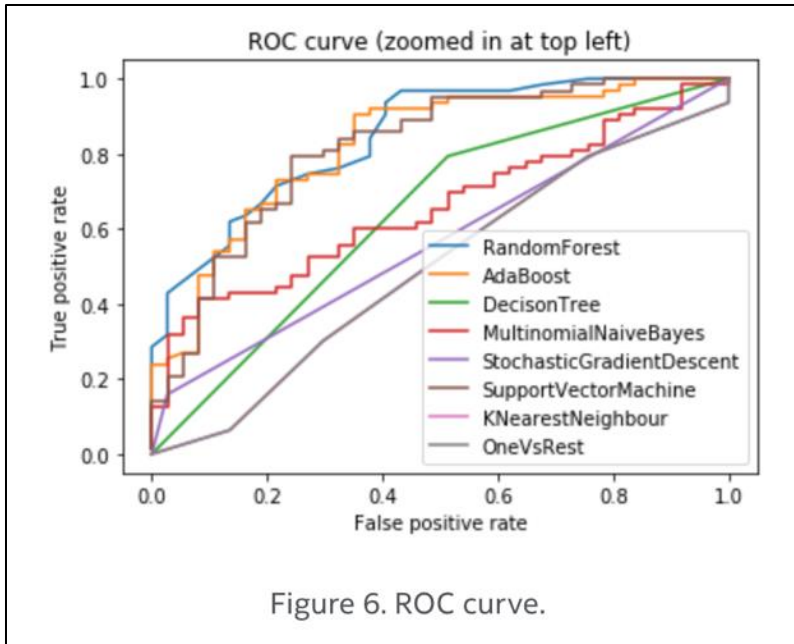

Source: <https://software.intel.com/content/www/us/en/develop/articles/credit-risk-classification-faster-machine-learning-with-intel-optimized-packages.html> at p.9

161. On information and belief, Defendant Intel performs each limitation of claim 22 of

the '483 patent:

“22. A computer-implemented method comprising:

(a) inputting into a computer processor programmed to execute a support vector machine a set of training examples having known labels with regard to two or more classes, each training example described by a vector of feature values for a plurality of features, the support vector machine comprising a decision function having a plurality of weights, wherein each feature has a corresponding weight;

(b) training the support vector machine by optimizing the plurality of weights so that a cost function is minimized and support vectors comprising a subset of the training examples are defined, wherein the decision function is based on the support vectors;

(c) computing ranking criteria using the optimized plurality of weights, wherein the ranking criterion estimates for each feature the effect on the cost function of removing that feature, and wherein features having the smallest effect on the cost function have the smallest ranking criteria;

(d) eliminating one or more features corresponding to the smallest ranking criteria to yield a reduced set of features;

(e) repeating steps (c) through (d) for the reduced set of features for a plurality of iterations until a subset of features of predetermined size remains, wherein the subset of features comprises determinative features for separating the set of training examples into the two or more classes; and

(f) transferring a listing of the determinative features to a media.”

162. As shown in paragraph 161, independent claim 22 is also directed to a computer-implemented method for identifying a determinative list of features for predicting patterns in the data, and is of similar content and scope to claim 1, with differences related to how the determinative list of features is presented, either by print or displaying in claim 1 versus transferring the list to a form of media in claim 22. Accordingly, the direct infringement allegations of ¶¶ 154-160 are incorporated by reference herein and apply to claims 22. Defendant Intel's accused products and software perform and infringe each limitation of claim 22.

163. On information and belief, Defendant Intel performs each limitation of claim 7 of the '483 patent:

7. A computer-program product embodied on a non-transitory computer-readable medium comprising instructions for executing a support vector machine, and further comprising instructions for:

training the support vector machine to determine a value for each feature in a group of features provided by a set of training samples having known labels corresponding to two or more classes, wherein training comprises generating a kernel matrix of components, each component comprising a dot product of two training samples, and adjusting a multiplier corresponding to each training sample to minimize a cost function;

eliminating at least one feature with a minimum value from the group to provide a reduced group of features;

generating an updated kernel matrix using the reduced group of features while keeping the multiplier unchanged;

determining an updated value for each feature in the reduced group of features;

repeating the steps of eliminating at least one feature, generating an updated kernel matrix and determining an updated value until a predetermined number of features remains; and

outputting a ranked list of features.

164. As shown in paragraph 163, independent claim 7 is directed to a computer program product for outputting a ranked list of features. Claim 7 is of similar content and scope to claim 1, with respect to the basic weighing, ranking and eliminating steps of an RFE method. Claim 7 further includes generating and updating a kernel matrix. On information

and belief, Defendant Intel's accused products and software embody these limitations. For example, Intel DAAL includes both Linear and Radial Basis Function Kernel classes, and the particular class would be selected by the user based on the dataset and features, and the predicted outcomes. Note that Radial Basis Function Kernels are commonly used in support vector machine classification.

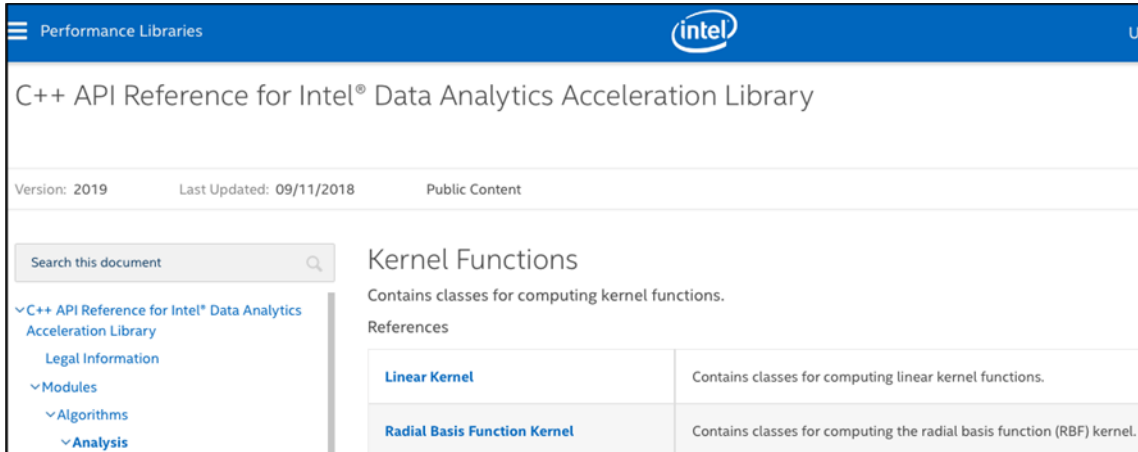

Source: <https://software.intel.com/content/www/us/en/develop/documentation/daal-cpp-api-reference/top/modules/algorithms/analysis/kernel-functions.html?wapkw=%22preprocessing%22%20and%20%22kernel%22>

Reasonable discovery will confirm this interpretation. Accordingly, the direct infringement allegations of ¶¶ 154-160 are incorporated by reference herein and apply to claim 7. Defendant Intel's accused products and software perform and infringe each limitation of claim 7.

165. On information and belief, Defendant Intel performs each limitation of claim 13 of the '483 patent:

"13. A non-transitory machine-readable medium comprising a plurality of instructions, which in response to being executed, result in a computing system:

(a) training a support vector machine by generating a kernel matrix from a set of training samples and adjusting a multiplier corresponding to each training sample to minimize a cost function;

(b) determining a weight value for each feature in a group of features that describe the training samples;

(c) eliminating at least one feature with a minimum weight value from the group;

(d) generating an updated kernel matrix while keeping the multiplier unchanged;

- (e) updating the weight value for each feature of the group based on the updated kernel matrix;
- (f) repeating steps (c) through (e) until a predetermined number of features remains to generate a ranked list of features; and
- (g) generating a report to a printer or display device comprising the ranked list of features.”

166. On information and belief, Defendant Intel performs each limitation of claim 18 of the ‘483 patent:

18. A non-transitory machine-readable medium comprising a plurality of instructions, which in response to being executed, result in a computing system:

identifying a determinative subset of features that are most correlated to patterns in sample data by:

retrieving a training data having class labels with respect to the patterns from a memory in communication with a computer processor programmed for executing a support vector machine comprising a kernel;

calculating a kernel matrix using the training data to determine a value for each feature in the group of features;

eliminating at least one feature with a minimum value from the group;

calculating an updated kernel matrix, each component of the updated kernel matrix comprising a dot product of two training samples provided by at least a part of the training data that corresponds to the eliminated feature;

determining an updated value for each remaining feature of the group of features based on the updated kernel matrix;

repeating steps eliminating, calculating an updated kernel matrix and determining an updated value for a plurality of iterations until a pre-determined number of features in the group remain; and

generating an output comprising a ranked list of features, wherein the features in the ranked list comprise the determinative subset of features for predicting patterns in new data.

167. On information and belief, Defendant Intel performs each limitation of claim 32 of the ‘483 patent:

32. A non-transitory machine-readable medium comprising a plurality of instructions, which in response to being executed, result in a computing system:

(a) training a support vector machine by generating a kernel matrix from a set of training samples and adjusting a multiplier corresponding to each training sample to minimize a cost function;

(b) determining a weight value for each feature in a group of features that describe the training samples;

(c) eliminating at least one feature with a minimum weight value from the group;

(d) generating an updated kernel matrix while keeping the multiplier unchanged;

(e) updating the weight value for each feature of the group based on the updated kernel matrix;

(f) repeating steps (c) through (e) until a predetermined number of features remains to generate a ranked list of features; and

(g) transferring the ranked list of features to a media.

168. As shown in paragraphs 165-167, independent claims 13, 18 and 32 are directed to a non-transitory machine-readable medium for outputting a ranked list of features. Claims 13, 18 and 32 are of similar content and scope to claim 1, with respect to the basic weighing, ranking and eliminating steps of an RFE method. Claims 13, 18 and 32 further include generating and updating a kernel matrix. On information and belief, Defendant Intel's accused products and software embody these kernel limitations, as set forth in ¶ 164 above, and are incorporated herein by reference. Reasonable discovery will confirm this interpretation. Accordingly, the direct infringement allegations of ¶¶ 154-160 are incorporated by reference herein and apply to claims 13, 18 and 32. Defendant Intel's accused products and software perform and infringe each limitation of claims 13, 18, and 32.

169. On information and belief, Defendant Intel's accused products and software embody each limitation of the dependent claims 2-6, 8-12, 14-17, 19-21, 23-31 and 33-38 of the '483 patent. Reasonable discovery will confirm this interpretation and confirm exactly which Intel products implement and use (in testing, validating, verifying, optimizing, operating, etc.) HDC's patented SVM-RFE machine-learning algorithm.

Defendant's Direct Infringement of the Method Claims

170. Defendant performs the methods recited in claims 1-6 and 23-31 of the '483 patent. Infringement of a method claim requires performing every step of the claimed method. Defendant performs every step of the methods recited in claims 1-6 and 23-31. As set

forth above, Defendant performs, for example, the method recited in claim 1, *i.e.*, A computer-implemented method comprising: (a) inputting into a computer processor programmed to execute a support vector machine a set of training examples having known labels with regard to two or more classes, each training example described by a vector of feature values for a plurality of features, the support vector machine comprising a decision function having a plurality of weights, wherein each feature has a corresponding weight; (b) training the support vector machine by optimizing the plurality of weights so that a cost function is minimized and support vectors comprising a subset of the training examples are defined, wherein the decision function is based on the support vectors; (c) computing ranking criteria using the optimized plurality of weights, wherein the ranking criterion estimates for each feature the effect on the cost function of removing that feature, and wherein features having the smallest effect on the cost function have the smallest ranking criteria; (d) eliminating one or more features corresponding to the smallest ranking criteria to yield a reduced set of features; (e) repeating steps (c) through (d) for the reduced set of features for a plurality of iterations until a subset of features of predetermined size remains, wherein the subset of features comprises determinative features for separating the set of training examples into the two or more classes; and (f) generating at a printer or display device an output comprising a listing of the determinative features.

171. Even if one or more steps recited in method claims 1-6 and 23-31 of the '483 patent are performed on technologies, computers, workstations, network-computer architectures, cloud-based architectures, etc., not in the physical possession of the Defendant (*e.g.*, in the possession of Intel partners, resellers, end-users, etc.), the claimed methods are

specifically performed by Intel's processors, FPGAs, SoCs, and/or software. Defendant directly infringes as its processors, FPGAs, SoCs, and/or software dictate the performance of the claimed steps, such as the "inputting," "training," "computing," "eliminating," "repeating," and "generating" steps recited in claim 1 of the '483 patent. Defendant's processors, FPGAs, SoCs, and/or software are designed and built by Defendant to perform the claimed steps automatically. Such processors, FPGAs, SoCs, and/or software predict and identify patterns in data. On information and belief, only Defendant can modify the functionality relating to these activities; no one else can modify such functionality. Defendant therefore performs all of the claimed steps and directly infringe the asserted method claims of the '483 patent.

172. *Additionally or alternatively*, to the extent third parties or end-users perform one or more steps of the methods recited in claims 1-6 and 23-31 of the '483 patent, any such action by third parties or end-users is attributable to Defendant, such that Defendant is liable for directly infringing such claims in a multiple actor or joint infringement situation, because Defendant directs or controls the other actor(s). In this regard, Defendant conditions participation in activities, as well as the receipt of benefits, upon performance of any such step by any such third party or end-user. Defendant exercises control over the methods performed by its processors, FPGAs, SoCs, and/or software, and benefit from others' use, including without limitation creating and receiving ongoing revenue streams from the accused products and related goods, and improvement/enhancement of its processors, FPGAs, SoCs, and/or software. End-users and third parties receive a benefit from fiscal gains (*e.g.*, third-party developers embedding Defendant's processors, FPGAs, SoCs, and/or software in their own products) and efficient and optimized data output –

which forms the basis of entire businesses. Defendant also establishes the manner and timing of that performance by the third-party or end-user, as dictated by the claimed method steps. All third-party and end-user involvement, if any, is incidental, ancillary, or contractual.

173. Thus, to the extent that any step of the asserted method claims is performed by someone other than Defendant (*e.g.*, an end-user), Defendant nonetheless directly infringes the '483 patent at least by one or more of: (1) providing processors, FPGAs, SoCs, and/or software built and designed to perform methods covered by the asserted method claims; (2) dictating via software and associated directions and instructions (*e.g.*, to end-users) the use of the accused products such that, when used as built and designed by Defendant, such products perform the claimed methods; (3) having the ability to terminate others' access to and use of the accused products and related goods and services if the accused products are not used in accordance with Defendant's required terms; (4) marketing and advertising the accused products, and otherwise instructing and directing the use of the accused products in ways covered by the asserted method claims; and (5) updating and providing ongoing support and maintenance for the accused products.

**Defendant's Direct Infringement of the Computer Program Product
and Non-transitory Machine-readable Medium Claims**

174. Defendant makes, uses, sells, offers to sell, and/or imports the computer program products recited in claims 7-12 and the non-transitory machine-readable mediums recited in claims 13-17, 18-21, and 32-38. Such claims are infringed when an accused product or medium, having every element of the claimed product or medium, is made, used, sold, offered for sale, or imported within the United States. Defendant makes, uses, sells, offers to sell, and/or imports the accused products (or cause such acts to be performed on its

behalf), which possess every element recited in claims 7-12, 13-17, 18-21 and 32-38, as set forth in more detail above (with independent claims 7, 13, 18 and 32 as representative). Defendant therefore directly infringes the computer program product and method claims of the '483 patent.

175. ***Additionally or alternatively***, regarding any “use” of the accused products “by customers,” which is a subset of the direct infringement of system claims, Defendant directly infringes in such situations if the machine-readable medium claims are determined to be system claims, as Defendant puts the accused products and services into service and, at the same time, controls the system as a whole and obtains benefit from it. Defendant provides all components in the system and controls all aspects of its functionality. Although third parties (*e.g.*, Intel partners, etc.) and end-users (*e.g.*, developers, professionals, businesses, etc.) may have physical control over certain aspects of the accused systems, Defendant retains control over how the accused system operates (*e.g.*, by having built and designed its processors, FPGAs, SoCs, and/or software to automatically identify patterns in datasets in a particular, non-modifiable manner). The nature and extent of Defendant’s control over the system, and the benefits realized from each element of the claims, was discussed above in connection with the asserted method claims. Such discussion is incorporated herein by reference. Defendant collects valuable data through its control of this system, which in turn is used to optimize, improve, and enhance Intel’s systems, products, services, etc. as a whole – again benefitting Defendant.

176. ***In the alternative***, if the end-user or third-party is deemed to put the invention into service and controls the system as a whole, the end-user and third-party benefit from each element of the claims because Defendant’s processors, FPGAs, SoCs, and/or software are

designed and built by Defendant to perform the claimed steps automatically. End-users (*e.g.*, developers, professionals, businesses, etc.) receive a benefit from putting the invention into service and automatically identifying patterns in datasets, thereby optimizing *e.g.*, workloads and workflows. Third parties (*e.g.*, Intel partners, etc.) receive a benefit from putting the invention into service by improving their own products and service, which improves their own profits. Further, and on information and belief, third-party partners share a fiscally/contractually beneficial relationship with Intel. In both cases, Intel would be liable as an inducing infringer as described below.

Induced Infringement

177. Defendant has induced and will continue to induce others' infringement of claims 1-38 of the '483 patent, in violation of 35 U.S.C. § 271(b). Defendant has actively encouraged infringement of the '483 patent, knowing that the acts it induced constituted infringement of the '483 patent, and its encouraging acts actually resulted in direct patent infringement by others.

178. As discussed above, Defendant had actual and constructive knowledge of the '483 patent, as well as actual and constructive knowledge of the relevance and significance of the '483 patent to its research and development, as well as its product offerings, at least no later than May 19, 2005 (per scholarly article), no later than November 10, 2011 (per HDC direct correspondence), and certainly no later than January 31, 2012 (per family-to-family USPTO citation).

179. To the extent Defendant do not specify and control the relevant algorithms and machine learning capabilities of the accused products in the claimed manner (which it does), Defendant—with full knowledge of the '483 patent and its relevance to Intel's

product offerings—actively encourages others (*e.g.*, end-users and third parties such as professionals, businesses, developers, Intel partners, etc.)—to use the accused products as claimed. Such active encouragement by Defendant takes many forms, and includes promotional and instructional materials, as well as technical specifications and requirements, and ongoing technical assistance.

180. On information and belief, Defendant engaged in these acts with the actual intent to cause the acts which it knew or should have known would induce actual infringement, or otherwise exercised willful blindness of a high probability that it has induced infringement.

Contributory Infringement

181. Defendant has contributed and will continue to contribute to others' infringement of claims 1-38 of the '483 patent, in violation of 35 U.S.C. § 271(c). Defendant has offered to sell and sold within the United States, or imported into the United States, material or apparatus for use in practicing the patented computer-implemented methods, claims 1-6 and 22-31, constituting a material part of the patented methods, knowing the same to be especially made or especially adapted for use in infringing the '483 patent, and not a staple article or commodity of commerce for substantial non-infringing use. Defendant has offered to sell and sold within the United States, or imported into the United States, at least some of the components of the claimed computer program products and non-transitory machine-readable medium, claims 7-12, 13-17, 18-21, and 32-38, constituting a material part of the patented computer program products and mediums, knowing the same to be especially made or especially adapted for use in infringing the '483 patent, and not a staple article or commodity of commerce for substantial non-infringing use.

182. As discussed above, Defendant had actual and constructive knowledge of the ‘483 patent, as well as actual and constructive knowledge of the relevance and significance of the ‘483 patent to its research and development, as well as its product offerings, at least no later than May 19, 2005 (per scholarly article), no later than November 10, 2011 (per HDC direct correspondence), and certainly no later than January 31, 2012 (per family-to-family USPTO citation).

183. To the extent Defendant do not specify and control the relevant algorithms and machine learning capabilities of the accused products in the claimed manner (which it does), Defendant supplies the accused products to others (*e.g.*, end-users and third parties) that perform the claimed dataset pattern identification and optimization, and/or that, when combined with other components, constitute the claimed computer implemented methods. The accused products embody SVM-RFE processes, which constitute a material part of the claimed inventions, if not the entire claimed inventions themselves. Defendant dictates and controls the optimization and identification componentry and techniques in the accused products, with full knowledge of the ‘483 patent and its relevance to its research development, as well as its product offerings, and know the same to be especially made and especially adapted for the infringement of the ‘483 patent.

184. On information and belief, the portions of Defendant’s products that identify patterns in data and implement SVM-RFE, including Intel branded products made, marketed, used, sold, offered to sell, or imported by Defendant, are not staple articles or commodities of commerce suitable for substantial non-infringing use.

Willful Infringement

185. As set forth above, Defendant had actual and constructive knowledge of the ‘483 patent, as well as actual and constructive knowledge of the relevance and significance of the ‘483 patent to its research and development, as well as its product offerings, at least no later than May 19, 2005 (per scholarly article), no later than November 10, 2011 (per HDC direct correspondence), and certainly no later than January 31, 2012 (per family-to-family USPTO citation).

186. Still further, as set forth in ¶¶ 30-31 *supra*, Plaintiff and Defendant were engaged in an Interference proceeding in the USPTO, that began on September 19, 2016 and ended in February 2019. On February 27, 2019, the USPTO ruled in favor of Health Discovery Corporation on the SVM-RFE Patent application, finding that Health Discovery Corporation was entitled to claim exclusive ownership rights to the SVM-RFE technology as set forth in the SVM-RFE Patent application that was filed to provoke the Interference. The decision ordered Intel Corporation’s Patent No. 7,685,077 to be cancelled. The decision also dismissed Intel Corporation’s motions challenging the validity of Health Discovery Corporation’s pending claims and issued patents covering SVM-RFE. On September 3, 2019, the USPTO issued U.S. Patent No. 10,402,685 (“SVM-RFE Patent”) (one of the Patents-in-Suit) for Health Discovery Corporation’s patent application covering SVM-RFE methods.

187. Defendant therefore had continuing actual and constructive knowledge of HDC’s SVM-RFE patent portfolio, which included the ‘483 patent, and the relevance and significance of the SVM-RFE portfolio to Intel’s research and development.

188. Defendant's infringement, as demonstrated above, is egregious, and combined with Defendant's clear knowledge, has been willful. Plaintiff respectfully requests that the Court award enhanced damages based on Defendant's conduct.

Damage to Health Discovery Corporation

189. On information and belief, Defendant's actions have and will continue to constitute direct and indirect (induced and contributory) infringement of at least claims 1-38 of the '483 patent in violation of 35 U.S.C. §271.

190. As a result of Defendant's infringement of at least claims 1-38 of the '483 patent, HDC has suffered monetary damages in an amount yet to be determined, in no event less than a reasonable royalty, and will continue to suffer damages in the future unless Defendant's infringing activities are enjoined by this Court.

191. Defendant's wrongful acts have damaged and will continue to damage HDC irreparably, and Plaintiff has no adequate remedy at law for those wrongs and injuries. In addition to its actual damages, Plaintiff HDC is entitled to a permanent injunction restraining and enjoining Defendant and its respective agents, servants, and employees, and all person acting thereunder, in concert with, or on its behalf, from infringing at least claims 1-38 of the '483 patent.

COUNT IV
INFRINGEMENT OF THE '685 PATENT

192. Plaintiff HDC repeats and realleges the above paragraphs, which are incorporated by reference as if fully restated herein.

193. Plaintiff HDC is the owner by assignment of all right, title, and interest in the '685 patent, including all right to recover for any and all infringement thereof.

194. Defendant is not licensed or otherwise authorized to practice the '685 patent.

195. The '685 patent is valid and enforceable. In this regard, the '685 patent is presumed valid under 35 U.S.C. §282.

196. The '685 patent relates to, among other things, methods and non-transitory machine-readable mediums for using learning machines (*e.g.*, Support Vector Machines) to identify relevant patterns in datasets and select relevant features within the datasets to optimize data classification (*e.g.*, as Recursive Feature Elimination). The '685 patent invented such methods, for example, as automated knowledge discovery tools. The '685 invention is directed, for example, at biological systems to improve diagnosing and predicting *e.g.*, diseases; and testing and treating individuals with changes in their biological systems.

197. On information and belief, Defendant manufactures and markets infringing products. *See*, ¶¶ 52-54, *supra*. Such products infringe on the inventive aspects of the '685 patent and include, *inter alia*, Intel processors (*e.g.*, Intel Xeon series; etc.) and Intel Field Programmable Gate Arrays (FPGAs) and System on Chips (SoCs) (*e.g.*, Intel Agilex Series; Intel Stratix Series; etc.), and Intel software (*e.g.*, Intel Data Analytics Acceleration Library). Intel processors, FPGAs, SoCs, and software are deployed in Intel/Intel-partnered computers, workstations, network-computer architectures, and cloud-based architectures. Intel uses machine learning software programs in-house to test, validate, verify and optimize their processors and conduct comparative studies, and these machine learning software programs employ SVM-RFE methods claimed in HDC's patents.

198. The '685 patent has been cited in one (1) U.S. patent filed by an industry leader, namely Google LLC.

199. Still further, as set forth in ¶¶ 30-31 *supra*, Plaintiff and Defendant were engaged in an Interference proceeding in the USPTO, that began on September 19, 2016 and ended in February 2019. On February 27, 2019, the USPTO ruled in favor of Health Discovery Corporation on the SVM-RFE Patent application, finding that Health Discovery Corporation was entitled to claim exclusive ownership rights to the SVM-RFE technology as set forth in the SVM-RFE Patent application that was filed to provoke the Interference. The decision ordered Intel Corporation's Patent No. 7,685,077 to be cancelled. The decision also dismissed Intel Corporation's motions challenging the validity of Health Discovery Corporation's pending claims and issued patents covering SVM-RFE. On September 3, 2019, the USPTO issued U.S. Patent No. 10,402,685 ("SVM-RFE Patent") (one of the Patents-in-Suit) for Health Discovery Corporation's patent application covering SVM-RFE methods.

200. Therefore, Defendant had actual and constructive knowledge of the '685 patent, as well as actual and constructive knowledge of the relevance and significance of the '685 patent to its research and development, as well as its product offerings, at least no later than January 31, 2012 (per USPTO patent citations) and certainly no later than September 19, 2016 (per initiation of the Interference resulting in HDC's favor).

Defendant's Direct Infringement of the '685 Patent

201. On information and belief, in violation of 35 U.S.C. § 271(a), Defendant has directly infringed, continues to directly infringe, and will continue to directly infringe absent the Court's intervention one or more claims of the '685 patent, including for example (but not limited to) at least method claims 1-6 and 18-23, and non-transitory machine-readable medium claims 7-11 and 12-17 of the '685 patent, either literally or

under the doctrine of equivalents, by making, using, testing, selling, and/or offering to sell within the United States, or importing into the United States, without license or authority, Defendant's infringing products, including, but not limited to, at least Intel AI-optimizing/machine learning processors, FPGAs, SoCs, and/or software – which are, *inter alia*, deployed in Intel/Intel-partnered computers, workstations, network-computer architectures, and cloud-based architectures. Defendant's infringing products also include software applications or libraries that incorporate SVM-RFE algorithms, such as Intel's Data Analytics Acceleration Library (DAAL) that utilizes SVM-RFE algorithms contained in the scikit-learn open source software. The following products and software are representative, *see* paragraphs 52-54 *supra*, of Intel's infringement.

Direct Infringement Allegations

202. On information and belief, Intel's infringing products contain substantially similar componentry and functionality at least insofar as the claimed inventions are concerned. The allegations below illustrate how Intel's infringing products (*e.g.*, processors, FPGAs, SoCs, and Software) embody the claimed computer-implemented methods, computer program products, and non-transitory machine-readable mediums. Such infringement by these products is exemplified through the independent claims of the '685 patent, which are representative of the scope of Intel's infringement.

203. As Defendant Intel is in the sole and complete possession of its relevant source code, algorithms, etc., with such information not publicly available, Plaintiff HDC respectfully requests early, limited discovery to confirm which Intel products and uses by Intel infringe. *See* ¶ 56.

204. Plaintiff HDC is requesting early discovery to confirm exactly which Intel products or uses of the SVM-RFE invention infringe the '685 patent. Due to the nature of Intel's business, the information required to determine exactly which Intel products or uses infringe is, in large part, not publicly available. However, although said information is not publicly available, Intel has publicly admitted (on several occasions) that it uses/used SVM-RFE in the development and optimization of its products (software, hardware, packages, libraries, etc.). HDC did not authorize Intel's use of SVM-RFE, for any reason, and therefore Intel's admissions of using SVM-RFE makes it highly probable that Intel is infringing the '685 patent. Intel may also be using the SVM-RFE technology, but referring to it by a different name to conceal infringing activities. The following citations, *inter alia*, include examples of Intel's admissions in the past, and there is no reason to believe they have ceased using the invention. *Supra* ¶ 35 for additional publications.

- a. A. Jaleel, et al., "Last Level Cache (LLC) Performance in Data Mining Workloads on a CMP – A Case Study of Parallel Bioinformatics Workloads," *Proc. of the 12th Int'l Symp. on High Performance Computer Architecture (HPCA)*, 2006. [2 of 3 authors were Intel employees]. **Exhibit N.**
- b. Y. Chen, et al., "Performance Scalability of Data-Mining Workloads in Bioinformatics," *Intel Technology Journal*, Vol. 9, No. 2, May 19, 2005. [9 of 9 authors were Intel employees, including the two named inventors of Intel SVM-RFE patent US7,685,077]. **Exhibit I.**
- c. U. Srinivasan, et al., "Characterization and Analysis of HMMER and SVM-RFE Parallel Bioinformatics Applications," *Proc. of the IEEE Int'l Symp. on Workload Characterization (IISWC)*, Oct. 2005. [8 of 8 authors were Intel employees;

including the two named inventors of Intel SVM-RFE patent US7,685,077] [In endnote 7, authors attribute SVM-RFE to Guyon and Weston, two of the named inventors of the ‘685 patent]. **Exhibit J.**

205. On information and belief, Defendant Intel performs each limitation of claim 1 of the ‘685 patent:

“1. A method, comprising:

retrieving training data from one or more storage devices in communication with a processor, the processor operable for:

determining a value for each feature in a group of features provided by the training data;

eliminating at least one feature with a minimum ranking criterion from the group, wherein the minimum ranking criterion is obtained based on the value for each feature in the group;

subtracting a matrix from the kernel data to provide an updated kernel data, each component of the matrix comprising a dot product of two of training samples provided by at least a part of the training data that corresponds to the eliminated feature;

updating the value for each feature of the group based on the updated kernel data;

repeating of eliminating the at least one feature from the group and updating the value for each feature of the group until a number of features in the group reaches a predetermined value to generate a feature ranking list; and

recognizing a new data corresponding to the group of features with the feature ranking list.”

206. On information and belief, Defendant Intel’s accused products and software, through their optimization, development, sale, and operation, embody HDC’s patented method. Reasonable discovery will confirm this interpretation. As evidence, and for example, one such computer-implemented method from the bioinformatics community was conducted by Intel engineers on a liver patient dataset to predict whether a person has liver disease (hereinafter “*liver patient dataset*”). See <https://software.intel.com/content/www/us/en/develop/articles/liver-patient-dataset-classification-using-the-intel-distribution-for-python.html> at page 1 (published May 3, 2018). As an additional example, one such computer-implemented method from the

financial metrics community was conducted by Intel engineers on a credit risk dataset to predict whether a person is a good credit risk or not (hereinafter “*credit risk dataset*”) (published April 20, 2018).

“Using the advantage of optimized scikit-learn* (Scikit-learn with Intel DAAL) that comes with Intel® Distribution for Python, we were able to achieve good results for the prediction problem.”

Source:< <https://software.intel.com/content/www/us/en/develop/articles/credit-risk-classification-faster-machine-learning-with-intel-optimized-packages.html>> p.1

“Using Intel optimized performance libraries in Intel® Xeon® Gold 6128 processor helped machine-learning applications to make predictions faster.”

Source:< <https://software.intel.com/content/www/us/en/develop/articles/credit-risk-classification-faster-machine-learning-with-intel-optimized-packages.html>> p.10

207. On information and belief, Defendant Intel’s accused products and software, through their optimization, development, sale, and operation, embody HDC’s patented method comprising retrieving training data from one or more storage devices in communication with a processor, the processor operable for performing the succeeding limitations. Reasonable discovery will confirm this interpretation. As evidence, and for example, Intel used the *liver patient dataset* comprising a plurality of features (*e.g.*, ten), and two classes (*e.g.*, liver patient or not) as shown in Table 2 below:

Liver Patient Dataset

Table 2. Dataset description.

Attribute Name	Attribute Description
V1	Age of the patient. Any patient whose age exceeded 89 is listed as being age 90.
V2	Gender of the patient
V3	Total bilirubin
V4	Direct bilirubin
V5	Alkphos alkaline phosphatase
V6	Sgpt alanine aminotransferase
V7	Sgot aspartate aminotransferase
V8	Total proteins
V9	Albumin
V10	A/G ratio albumin and globulin ratio
Class	Liver patient or not

Source:< <https://software.intel.com/content/www/us/en/develop/articles/liver-patient-dataset-classification-using-the-intel-distribution-for-python.html> > p.2

Feature selection is used to identify the most important features in the dataset that can build the model from the dataset.

“Feature selection is mainly applied to large datasets to reduce high dimensionality. This helps to identify the most important features in the dataset that can be given for model building.”

Source:< <https://software.intel.com/content/www/us/en/develop/articles/liver-patient-dataset-classification-using-the-intel-distribution-for-python.html> > p.4

In the *liver patient dataset* example described by Intel engineers, they used the random forest algorithm (a classifier) in order to visualize feature importance. However, as shown in the graphical data below for the receiver operating characteristics (ROC), additional classifiers were used on the *liver patient dataset*, including a support vector machine (SVM).

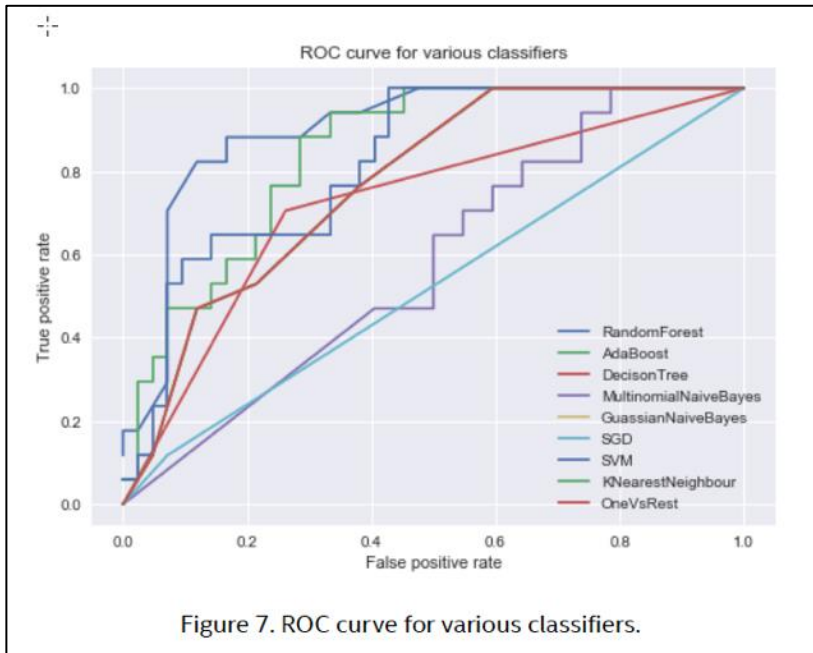

Source: <https://software.intel.com/content/www/us/en/develop/articles/liver-patient-dataset-classification-using-the-intel-distribution-for-python.html> at p.4

For the *credit risk dataset*, Intel's classification comprised a plurality of features (*e.g.*, 21), and two classes (*e.g.*, good credit or bad credit) as shown in Table 3 below:

Credit Risk Dataset

Table 3. Dataset Description.

Attribute Name	Attribute Description
checking_status	Status of existing checking account, in Deutsche Marks (DM)
duration	Duration in months
credit_history	Credit history (credits taken, paid back duly, delays, critical accounts)
purpose	Purpose of the credit (car, television, etc.)
credit_amount	Credit loan amount, in Deutsche Marks (DM)
savings_status	Status of savings account and bonds, in Deutsche Marks
employment	Present employment, in number of years
installment_commitment	Installment rate in percentage of disposable income
personal_status	Personal status (married, single, etc.) and sex
other_parties	Other debtors and guarantors
residence_since	Present residence since X years
property_magnitude	Property (e.g., real estate)
age	Age in years
other_payment_plans	Other installment plans (banks, stores, etc.)
housing	Housing (rent, own)
existing_credits	Number of existing credits at this bank
job	Job
num_dependents	Number of people being liable to provide maintenance for
own_telephone	Telephone (yes and no)
foreign_worker	Foreign worker (yes and no)
class	Good credit or bad credit

Source: <https://software.intel.com/content/www/us/en/develop/articles/credit-risk-classification-faster-machine-learning-with-intel-optimized-packages.html> at p.2-3

As shown in the graph below for the receiver operating characteristics (ROC), one of the support vector classifiers for the *credit risk dataset* is a support vector machine (SVM).

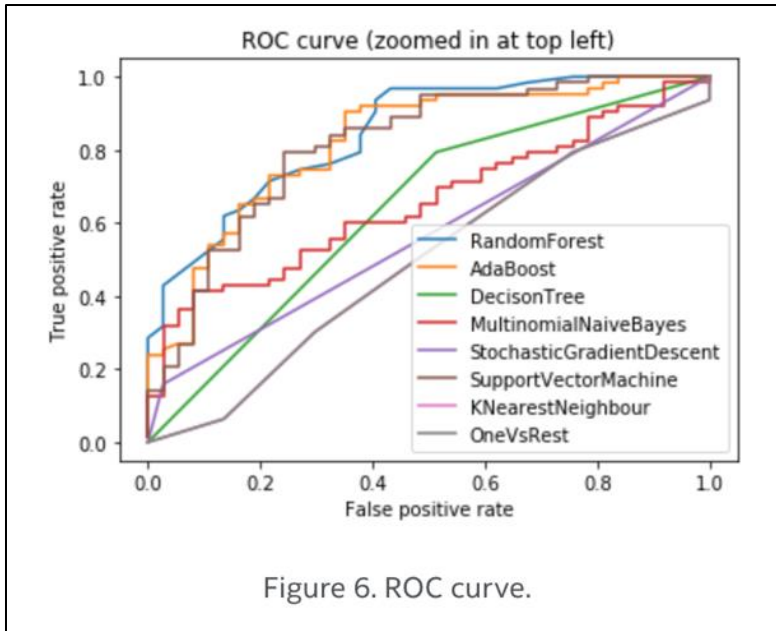

Source: <https://software.intel.com/content/www/us/en/develop/articles/credit-risk-classification-faster-machine-learning-with-intel-optimized-packages.html> at p.9

208. On information and belief, Defendant Intel's accused products and software, through their optimization, development, sale, and operation, embody HDC's patented method comprising retrieving training data from one or more storage devices in communication with a processor, the processor operable for determining a value for each feature in a group of features provided by the training data. Reasonable discovery will confirm this interpretation. For example, and on information and belief, Intel optimizes the plurality of weights and determines the relative importance of the features within their processors, FPGAs, SoCs, and/or software using Scikit-Learn (a machine learning library) function – `ExtraTreesClassifier()`. While Intel may have used this function in relation to an alternate feature selection algorithm, as shown above Intel has used up to eight other classifiers including SVM while conducting the *liver patient dataset* analysis.

“The ExtraTreesClassifier() function from the sklearn.ensemble package is used for calculation.”

Source:< <https://software.intel.com/content/www/us/en/develop/articles/liver-patient-dataset-classification-using-the-intel-distribution-for-python.html> > p.4

In the *liver patient dataset* method, 90% of the dataset was used to train the model, and 10% was used for testing/predicting the model outcomes. Another scikit-learn (a machine learning library) function was used to split the training and test data – StratifiedShuffleSplit.

“A part of the whole dataset was given for training the model and the rest was given for testing. In this experiment, 90 percent of the data was given for training and 10 percent for testing. Since StratifiedShuffleSplit (a function in scikit-learn) was applied to split the train-test data, the percentage of samples for each class was preserved, that is, in this case, 90 percent of samples from each class was taken for training and the remaining 10 percent from each class was given for testing. Classifiers from the scikit-learn package were used for model building.”

Source:< <https://software.intel.com/content/www/us/en/develop/articles/liver-patient-dataset-classification-using-the-intel-distribution-for-python.html> > p.5

For the *credit risk dataset* example, and on information and belief, the method included optimizing the plurality of weights and determining the relative importance of the features is calculated using scikit-learn.

“Classifier is implemented using two packages: scikit-learn with Intel DAAL and PyDAAL.”

Source: <<https://software.intel.com/content/www/us/en/develop/articles/credit-risk-classification-faster-machine-learning-with-intel-optimized-packages.html>> p.7

In the *credit risk dataset* method, 90% of the dataset was used to train the model, and 10% was used for testing/predicting the model outcomes.

“Data Split

Splitting the train and test data: The data is then split into train and test sets for further analysis. 90% of the data is used for training and 10% is for testing. The train_test_split function in scikit-learn is used for data splitting.”

Source: <<https://software.intel.com/content/www/us/en/develop/articles/credit-risk-classification-faster-machine-learning-with-intel-optimized-packages.html>> p.7

209. On information and belief, Defendant Intel’s accused products and software, through their optimization, development, sale, and operation, embody HDC’s patented method comprising retrieving training data from one or more storage devices in communication with a processor, the processor operable for eliminating at least one feature with a minimum ranking criterion from the group, wherein the minimum ranking criterion is obtained based on the value for each feature in the group. As evidence, and for *liver patient dataset* example, features with the smallest ranking criteria were made available to be eliminated, in this case it was V2 (gender of the patient), V8 (total proteins), V10 (A/G ratio albumin and globulin ratio), and V9 (albumin).

Liver Patient Dataset

“Removing the least significant features help to reduce the processing time without significantly affecting the accuracy of the model. Here V2 (gender of the patient), V8 (total proteins), V10 (A/G ratio albumin and globulin ratio), and V9 (albumin) are dropped in order to reduce the number of features for model building.”

Source: <https://software.intel.com/content/www/us/en/develop/articles/liver-patient-dataset-classification-using-the-intel-distribution-for-python.html> at p.4

For the *liver patient dataset* example, the rankings were computed and plotted on the graph shown in Figure 5 below, showing the relative importance of the features. Note, while Intel may have used the forest of trees algorithm for feature importance, as shown above Intel has used up to eight other classifiers including SVM during the *liver patient dataset* analysis.

“Figure 5 shows the feature importance with forests of trees. From the figure, it is clear that the most important feature is V5 (alkphos alkaline phosphatase) and the least important is V2 (gender).”

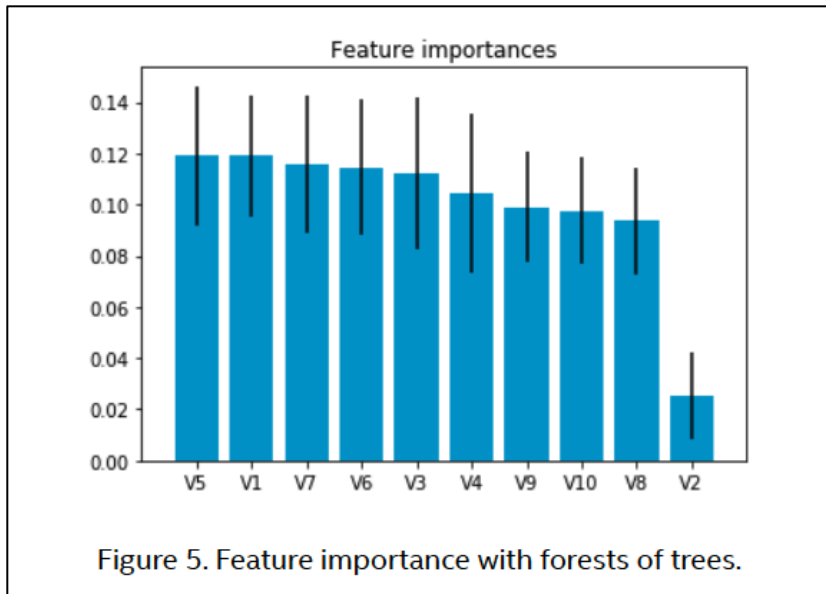

Source: <https://software.intel.com/content/www/us/en/develop/articles/liver-patient-dataset-classification-using-the-intel-distribution-for-python.html> at p.4

Credit Risk Dataset

The *credit risk dataset* example also used such a ranking criterion.

Feature Selection

“Datasets may contain irrelevant or redundant features that might make the machine-learning model more complicated. **In this step, we aim to remove the irrelevant features which may cause an increase in run time, generate complex patterns, etc.**”

Source: <https://software.intel.com/content/www/us/en/develop/articles/credit-risk-classification-faster-machine-learning-with-intel-optimized-packages.html> at p.6 (emphasis added)

For the *credit risk dataset* example, the rankings were computed and plotted on the graph shown in Table 5 below, showing the relative importance of the features.

Table 5. Feature Importance.

Feature	Score
credit_amount	0.1724
duration	0.1122
age	0.1057
purpose	0.0634
checking_status_no checking	0.0423
installment_commitment	0.0341
plan_none	0.0309
employment_4<=X<7	0.0293
residence_since	0.0260
credit_history_all paid	0.0244

Source: <https://software.intel.com/content/www/us/en/develop/articles/credit-risk-classification-faster-machine-learning-with-intel-optimized-packages.html> at p.4

210. On information and belief, Defendant Intel's accused products and software, through their optimization, development, sale, and operation, embody HDC's patented method comprising retrieving training data from one or more storage devices in communication with a processor, the processor operable for subtracting a matrix from the kernel data to provide an updated kernel data, each component of the matrix comprising a dot product of two of training samples provided by at least a part of the training data that corresponds to the eliminated feature. Reasonable discovery will confirm that Intel performs this limitation. For example, Intel DAAL includes both Linear and Radial Basis Function Kernel classes, and the particular class would be selected by the user based on the dataset and features, and the predicted outcomes. Note that Radial Basis Function Kernels are commonly used in support vector machine classification.

Performance Libraries  U

C++ API Reference for Intel® Data Analytics Acceleration Library

Version: 2019 Last Updated: 09/11/2018 Public Content

Search this document

- ✓ C++ API Reference for Intel® Data Analytics Acceleration Library
 - Legal Information
 - ✓ Modules
 - ✓ Algorithms
 - ✓ Analysis

Kernel Functions

Contains classes for computing kernel functions.

References

Linear Kernel	Contains classes for computing linear kernel functions.
Radial Basis Function Kernel	Contains classes for computing the radial basis function (RBF) kernel.

Source: <https://software.intel.com/content/www/us/en/develop/documentation/daal-cpp-api-reference/top/modules/algorithms/analysis/kernel-functions.html?wapkw=%22preprocessing%22%20and%20%22kernel%22>

211. On information and belief, Defendant Intel's accused products and software, through their optimization, development, sale, and operation, embody HDC's patented method comprising retrieving training data from one or more storage devices in communication with a processor, the processor operable for updating the value for each feature of the group based on the updated kernel data. Reasonable discovery will confirm this interpretation. For example, Intel DAAL includes both Linear and Radial Basis Function Kernel classes, and the particular class would be selected by the user based on the dataset and features, and the predicted outcomes. Note that Radial Basis Function Kernels are commonly used in support vector machine classification.

Performance Libraries 

C++ API Reference for Intel® Data Analytics Acceleration Library

Version: 2019 Last Updated: 09/11/2018 Public Content

Search this document

- ▼ C++ API Reference for Intel® Data Analytics Acceleration Library
 - Legal Information
 - ▼ Modules
 - ▼ Algorithms
 - ▼ Analysis

Kernel Functions

Contains classes for computing kernel functions.

References

Linear Kernel	Contains classes for computing linear kernel functions.
Radial Basis Function Kernel	Contains classes for computing the radial basis function (RBF) kernel.

Source: <https://software.intel.com/content/www/us/en/develop/documentation/daal-cpp-api-reference/top/modules/algorithms/analysis/kernel-functions.html?wapkw=%22preprocessing%22%20and%20%22kernel%22>

212. On information and belief, Defendant Intel’s accused products and software, through their optimization, development, sale, and operation, embody HDC’s patented method comprising retrieving training data from one or more storage devices in communication with a processor, the processor operable for repeating of eliminating the at least one feature from the group and updating the value for each feature of the group until a number of features in the group reaches a predetermined value to generate a feature ranking list. Reasonable discovery will confirm this interpretation.
213. On information and belief, Defendant Intel’s accused products and software, through their optimization, development, sale, and operation, embody HDC’s patented method comprising retrieving training data from one or more storage devices in communication with a processor, the processor operable for recognizing a new data corresponding to the group of features with the feature ranking list. Reasonable discovery will confirm this interpretation.
214. On information and belief, Defendant Intel performs each limitation of claim 7 of the ‘685 patent:

“7. A non-transitory machine-readable medium comprising a plurality of instructions, that in response to being executed, result in a computing system executing a support vector machine, comprising:

a training function to determine a value for each feature in a group of features provided by a training data; and

an eliminate function to eliminate at least one feature with a minimum ranking criterion from the group, wherein the minimum ranking criterion is obtained based on the value for each feature in the group, wherein the training function further comprises a kernel data function to subtract a matrix from the kernel data to provide an updated kernel data, each component of the matrix comprising a dot product of two of training samples provided by at least a part of the training data that corresponds to the eliminated feature, and a value update function to update the value for each feature based on the updated kernel data, and wherein the apparatus support vector machine further repeats eliminating the at least one feature from the group and updating the value for each feature of the group until a number of features in the group reaches a predetermined value, to generate a feature ranking list for a use of recognizing a new data corresponding to the group of features.”

215. On information and belief, Defendant Intel performs each limitation of claim 12 of the ‘685 patent:

“12. A non-transitory machine-readable medium comprising a plurality of instructions that in response to being executed result in a computing system:

determining a value for each feature in a group of features provided by a training data;

eliminating at least one feature with a minimum ranking criterion from the group, wherein the minimum ranking criterion is obtained based on the value for each feature in the group;

subtracting a matrix from the kernel data to provide an updated kernel data, each component of the matrix comprising a dot product of two of training samples provided by at least a part of the training data that corresponds to the eliminated feature;

updating the value for each feature of the group based on the updated kernel data;

repeating of eliminating the at least one feature from the group and updating the value for each feature of the group until a number of features in the group reaches a predetermined value to generate a feature ranking list; and

recognizing a new data corresponding to the group of features with the feature ranking list.”

216. As shown in paragraphs 214-215, independent claims 7 and 12 are directed to a non-transitory machine-readable medium for outputting a ranked list of features. Claims 7 and 12 are of similar content and scope to claim 1. Reasonable discovery will confirm this interpretation. Accordingly, the direct infringement allegations of ¶¶ 206-213 are

incorporated by reference herein and apply to claims 7 and 12. Defendant Intel's accused products and software perform and infringe each limitation of claims 7 and 12.

217. On information and belief, Defendant Intel performs each limitation of claim 18 of the '685 patent:

"18. A computer-implemented method for predicting patterns in sample data, wherein the sample data comprises a group of features that describe the data, the method comprising: identifying a determinative subset of features that are most correlated to the patterns comprising: retrieving a training data having class labels with respect to the patterns from a memory in communication with a computer processor programmed for executing a support vector machine comprising a kernel; calculating a kernel matrix using the training data to determine a value for each feature in the group of features; eliminating at least one feature with a minimum value from the group; calculating an updated kernel matrix, each component of the updated kernel matrix comprising a dot product of two training samples provided by at least a part of the training data that corresponds to the eliminated feature; determining an updated value for each remaining feature of the group of features based on the updated kernel matrix; repeating steps eliminating, calculating an updated kernel matrix and determining an updated value for a plurality of iterations until a pre-determined number of features in the group remain; and generating an output comprising a feature ranking list, wherein the features in the feature ranking list comprise the determinative subset of features for predicting patterns in new data."

218. As shown in paragraph 217, independent claim 18 is directed to a computer-implemented method for identifying a determinative list of features for predicting patterns in the data, and is of similar content and scope to the method claim 1. Reasonable discovery will confirm this interpretation. Accordingly, the direct infringement allegations of ¶¶ 206-213 are incorporated by reference herein and apply to claim 18. Defendant Intel's accused products and software perform and infringe each limitation of claim 18.

219. On information and belief, Defendant Intel's accused products and software embody each limitation of the dependent claims 2-6, 8-11, 13-17 and 19-23 of the '685

patent. Reasonable discovery will confirm this interpretation and confirm exactly which Intel products implement and use (in testing, validating, verifying, optimizing, operating, etc.) HDC's patented SVM-RFE machine-learning algorithm.

Defendant's Direct Infringement of the Method Claims

220. Defendant performs the methods recited in claims 1-6 and 18-23 of the '685 patent. Infringement of a method claim requires performing every step of the claimed method. Defendant performs every step of the methods recited in claims 1-6 and 18-23. As set forth above, Defendant performs, for example, the method recited in claim 1, *i.e.*, a method, comprising: retrieving training data from one or more storage devices in communication with a processor, the processor operable for: determining a value for each feature in a group of features provided by the training data; eliminating at least one feature with a minimum ranking criterion from the group, wherein the minimum ranking criterion is obtained based on the value for each feature in the group; subtracting a matrix from the kernel data to provide an updated kernel data, each component of the matrix comprising a dot product of two of training samples provided by at least a part of the training data that corresponds to the eliminated feature; updating the value for each feature of the group based on the updated kernel data; repeating of eliminating the at least one feature from the group and updating the value for each feature of the group until a number of features in the group reaches a predetermined value to generate a feature ranking list; and recognizing a new data corresponding to the group of features with the feature ranking list.

221. Even if one or more steps recited in method claims 1-6 and 18-23 of the '685 patent are performed on technologies, computers, workstations, network-computer architectures, cloud-based architectures, etc., not in the physical possession of the Defendant (*e.g.*, in

the possession of Intel partners, resellers, end-users, etc.), the claimed methods are specifically performed by Intel's processors, FPGAs, SoCs, and/or software. Defendant directly infringes as its processors, FPGAs, SoCs, and/or software dictate the performance of the claimed steps, such as the "retrieving," "determining," "eliminating," "subtracting," "updating," "repeating," and "recognizing" steps recited in claim 1 of the '685 patent. Defendant's processors, FPGAs, SoCs, and/or software are designed and built by Defendant to perform the claimed steps automatically. Such processors, FPGAs, SoCs, and/or software predict and identify patterns in data. On information and belief, only Defendant can modify the functionality relating to these activities; no one else can modify such functionality. Defendant therefore performs all of the claimed steps and directly infringe the asserted method claims of the '685 patent.

222. *Additionally or alternatively*, to the extent third parties or end-users perform one or more steps of the methods recited in claims 1-6 and 18-23 of the '685 patent, any such action by third parties or end-users is attributable to Defendant, such that Defendant is liable for directly infringing such claims in a multiple actor or joint infringement situation, because Defendant directs or controls the other actor(s). In this regard, Defendant conditions participation in activities, as well as the receipt of benefits, upon performance of any such step by any such third party or end-user. Defendant exercises control over the methods performed by its processors, FPGAs, SoCs, and/or software, and benefit from others' use, including without limitation creating and receiving ongoing revenue streams from the accused products and related goods, and improvement/enhancement of its processors, FPGAs, SoCs, and/or software. End-users and third parties receive a benefit from fiscal gains (e.g., third-party developers embedding Defendant's processors, FPGAs,

SoCs, and/or software in their own products) and efficient and optimized data output – which forms the basis of entire businesses. Defendant also establishes the manner and timing of that performance by the third-party or end-user, as dictated by the claimed method steps. All third-party and end-user involvement, if any, is incidental, ancillary, or contractual.

223. Thus, to the extent that any step of the asserted method claims is performed by someone other than Defendant (*e.g.*, an end-user), Defendant nonetheless directly infringes the ‘685 patent at least by one or more of: (1) providing processors, FPGAs, SoCs, and/or software built and designed to perform methods covered by the asserted method claims; (2) dictating via software and associated directions and instructions (*e.g.*, to end-users) the use of the accused products such that, when used as built and designed by Defendant, such products perform the claimed methods; (3) having the ability to terminate others’ access to and use of the accused products and related goods and services if the accused products are not used in accordance with Defendant’s required terms; (4) marketing and advertising the accused products, and otherwise instructing and directing the use of the accused products in ways covered by the asserted method claims; and (5) updating and providing ongoing support and maintenance for the accused products.

**Defendant’s Direct Infringement of the
Non-transitory Machine-readable Medium Claims**

224. Defendant makes, uses, sells, offers to sell, and/or imports the non-transitory machine-readable mediums recited in claims 7-11 and 12-17. Such claims are infringed when an accused product, having every element of the claimed medium, is made, used, sold, offered for sale, or imported within the United States. Defendant makes, uses, sells, offers to sell, and/or imports the accused products (or cause such acts to be performed on

its behalf), which possess every element recited in claims 7-17, as set forth in more detail in above (with independent claims 7 and 12 as representative). Defendant therefore directly infringes the medium claims of the '685 patent.

225. ***Additionally or alternatively***, regarding any “use” of the accused products “by customers,” which is a subset of the direct infringement of system claims, Defendant directly infringes in such situations if the machine-readable medium claims are determined to be system claims, as Defendant puts the accused products and services into service and, at the same time, controls the system as a whole and obtains benefit from it. Defendant provides all components in the system and controls all aspects of its functionality. Although third parties (*e.g.*, Intel partners, etc.) and end-users (*e.g.*, developers, professionals, businesses, etc.) may have physical control over certain aspects of the accused systems, Defendant retains control over how the accused system operates (*e.g.*, by having built and designed its processors, FPGAs, SoCs, and/or software to automatically identify patterns in datasets in a particular, non-modifiable manner). The nature and extent of Defendant’s control over the system, and the benefits realized from each element of the claims, was discussed above in connection with the asserted method claims. Such discussion is incorporated herein by reference. Defendant collects valuable data through its control of this system, which in turn is used to optimize, improve, and enhance Intel’s systems, products, services, etc. as a whole – again benefitting Defendant.

226. ***In the alternative***, if the end-user or third-party is deemed to put the invention into service and controls the system as a whole, the end-user and third-party benefit from each element of the claims because Defendant’s processors, FPGAs, SoCs, and/or software are designed and built by Defendant to perform the claimed steps automatically. End-users

(*e.g.*, developers, professionals, businesses, etc.) receive a benefit from putting the invention into service and automatically identifying patterns in datasets, thereby optimizing *e.g.*, workloads and workflows. Third parties (*e.g.*, Intel partners, etc.) receive a benefit from putting the invention into service by improving their own products and service, which improves their own profits. Further, and on information and belief, third-party partners share a fiscally/contractually beneficial relationship with Intel. In both cases, Intel would be liable as an inducing infringer as described below.

Induced Infringement

227. Defendant has induced and will continue to induce others' infringement of claims 1-23 of the '685 patent, in violation of 35 U.S.C. § 271(b). Defendant has actively encouraged infringement of the '685 patent, knowing that the acts it induced constituted infringement of the '685 patent, and its encouraging acts actually resulted in direct patent infringement by others.

228. As discussed above, Defendant had actual and constructive knowledge of the '685 patent, as well as actual and constructive knowledge of the relevance and significance of the '685 patent to its research and development, as well as its product offerings, at least no later than January 31, 2012 (per USPTO patent citations) and certainly no later than September 19, 2016 (per initiation of the Interference resulting in HDC's favor).

229. To the extent Defendant do not specify and control the relevant algorithms and machine learning capabilities of the accused products in the claimed manner (which it does), Defendant—with full knowledge of the '685 patent and its relevance to Intel's product offerings—actively encourages others (*e.g.*, end-users and third parties such as professionals, businesses, developers, Intel partners, etc.)—to use the accused products as

claimed. Such active encouragement by Defendant takes many forms, and includes promotional and instructional materials, as well as technical specifications and requirements, and ongoing technical assistance.

230. On information and belief, Defendant engaged in these acts with the actual intent to cause the acts which it knew or should have known would induce actual infringement, or otherwise exercised willful blindness of a high probability that it has induced infringement.

Contributory Infringement

231. Defendant has contributed and will continue to contribute to others' infringement of claims 1-23 of the '685 patent, in violation of 35 U.S.C. § 271(c). Defendant has offered to sell and sold within the United States, or imported into the United States, material or apparatus for use in practicing the patented methods, claims 1-6 and 18-23, constituting a material part of the patented methods, knowing the same to be especially made or especially adapted for use in infringing the '685 patent, and not a staple article or commodity of commerce for substantial non-infringing use. Defendant has offered to sell and sold within the United States, or imported into the United States, at least some of the components of the claimed non-transitory machine-readable mediums, claims 7-11 and 12-17, constituting a material part of the patented mediums, knowing the same to be especially made or especially adapted for use in infringing the '685 patent, and not a staple article or commodity of commerce for substantial non-infringing use.

232. As discussed above, Defendant had actual and constructive knowledge of the '685 patent, as well as actual and constructive knowledge of the relevance and significance of the '685 patent to its research and development, as well as its product offerings, at least

no later than January 31, 2012 (per USPTO patent citations) and certainly no later than September 19, 2016 (per initiation of the Interference resulting in HDC's favor).

233. To the extent Defendant do not specify and control the relevant algorithms and machine learning capabilities of the accused products in the claimed manner (which it does) Defendant supplies the accused products to others (*e.g.*, end-users and third parties) that perform the claimed dataset pattern identification and optimization, and/or that, when combined with other components, constitute the claimed computer implemented methods. The accused products embody SVM-RFE processes, which constitute a material part of the claimed inventions, if not the entire claimed inventions themselves. Defendant dictates and controls the optimization and identification componentry and techniques in the accused products, with full knowledge of the '685 patent and its relevance to its research development, as well as its product offerings, and know the same to be especially made and especially adapted for the infringement of the '685 patent.

234. On information and belief, the portions of Defendant's products that identify patterns in data and implement SVM-RFE, including Intel branded products made, marketed, used, sold, offered to sell, or imported by Defendant, are not staple articles or commodities of commerce suitable for substantial non-infringing use.

Willful Infringement

235. As set forth above, Defendant had actual and constructive knowledge of the '685 patent, as well as actual and constructive knowledge of the relevance and significance of the '685 patent to its research and development, as well as its product offerings, at least no later than January 31, 2012 (per USPTO patent citations) and certainly no later than September 19, 2016 (per initiation of the Interference resulting in HDC's favor).

236. Still further, as set forth in ¶¶ 30-31 *supra*, Plaintiff and Defendant were engaged in an Interference proceeding in the USPTO, that began on September 19, 2016 and ended in February 2019. On February 27, 2019, the USPTO ruled in favor of Health Discovery Corporation on the SVM-RFE Patent application, finding that Health Discovery Corporation was entitled to claim exclusive ownership rights to the SVM-RFE technology as set forth in the SVM-RFE Patent application that was filed to provoke the Interference. The decision ordered Intel Corporation's Patent No. 7,685,077 to be cancelled. The decision also dismissed Intel Corporation's motions challenging the validity of Health Discovery Corporation's pending claims and issued patents covering SVM-RFE. In September 2019, the USPTO issued U.S. Patent No. 10,402,685 ("SVM-RFE Patent") (one of the Patents-in-Suit) for Health Discovery Corporation's patent application covering SVM-RFE methods.

237. Defendant therefore had continuing actual and constructive knowledge of HDC's SVM-RFE patent portfolio, which included the '685 patent, and the relevance and significance of the SVM-RFE portfolio to Intel's research and development.

238. Defendant's infringement, as demonstrated above, is egregious, and combined with Defendant's clear knowledge, has been willful. Plaintiff respectfully request that the Court award enhanced damages based on Defendant's conduct.

Damage to Health Discovery Corporation

239. On information and belief, Defendant's actions have and will continue to constitute direct and indirect (induced and contributory) infringement of at least claims 1-23 of the '685 patent in violation of 35 U.S.C. §271.

240. As a result of Defendant's infringement of at least claims 1-23 of the '685 patent, HDC has suffered monetary damages in an amount yet to be determined, in no event less than a reasonable royalty, and will continue to suffer damages in the future unless Defendant's infringing activities are enjoined by this Court.

241. Defendant's wrongful acts have damaged and will continue to damage HDC irreparably, and Plaintiff has no adequate remedy at law for those wrongs and injuries. In addition to its actual damages, Plaintiff HDC is entitled to a permanent injunction restraining and enjoining Defendant and its respective agents, servants, and employees, and all person acting thereunder, in concert with, or on its behalf, from infringing at least claims 1-23 of the '685 patent.

PRAYER FOR RELIEF

WHEREFORE, Plaintiff Health Discovery Corporation respectfully requests that this Court enter:

- A. A judgment in favor of Plaintiff Health Discovery Corporation that Defendant has been and is infringing at least claims 1-23 of the '188 patent, claims 1-19 of the '959 patent, claims 1-38 of the '483 patent, and claims 1-23 of the '685 patent pursuant to 35 U.S.C. §§ 271(a), 271(b) and/or 271(c);
- B. A preliminary and permanent injunction enjoining Defendant and its respective officers, directors, agents, servants, affiliates, employees, divisions, branches, subsidiaries, parents, and all others acting in concert or privity with any of them from infringing, inducing the infringement of, or contributing to the infringement of at least claims 1-23 of the '188 patent, claims 1-19 of the '959 patent, claims 1-38 of the '483 patent, and claims 1-23 of the '685 patent;

- C. A judgment awarding Plaintiff Health Discovery Corporation all damages adequate to compensate it for Defendant's infringement of the HDC Patents, and in no event less than a reasonable royalty for Defendant's acts of infringement, including all pre-judgment and post-judgment interest at the maximum rate permitted by law, and including all past damages prior to filing this Complaint in accordance with 35 U.S.C. § 286, as a result of Defendant's infringement of at least claims 1-23 of the '188 patent, claims 1-19 of the '959 patent, claims 1-38 of the '483 patent, and claims 1-23 of the '685 patent;
- D. An award of enhanced damages as a result of Defendant Intel's willful infringement of at least claims 1-23 of the '188 patent, claims 1-19 of the '959 patent, claims 1-38 of the '483 patent, and claims 1-23 of the '685 patent, after being apprised of these patents, as provided under 35 U.S.C. § 284;
- E. An assessment of costs, including reasonable attorney fees pursuant to 35 U.S.C. § 285, and prejudgment interest against Defendant; and
- F. Such other and further relief as this Court may deem just and proper.

REQUEST FOR EARLY DISCOVERY

As Defendant Intel is in the sole and complete possession of its relevant source code, algorithms, etc., with such information not publicly available, Plaintiff HDC respectfully requests early, limited discovery pursuant to Local Rules (*i.e.*, Order Governing Procedures – Patent Case) to confirm which Intel products infringe.

JURY TRIAL DEMANDED

Pursuant to FED. R. CIV. P. 38, Plaintiff Health Discovery Corporation hereby demands a trial by jury on all issues so triable.

Dated: July 23, 2020

Respectfully submitted,

By: /s/ Erick Robinson
Erick Robinson (TX Bar No.
24039142)
Dunlap Bennett & Ludwig PLLC
7215 Bosque Blvd
Waco, TX 76710
Telephone: (254) 870-7302
Fax: (713) 583-9737
erobinson@dbllawyers.com

*Counsel for Health Discovery
Corporation*