

**IN THE UNITED STATES DISTRICT COURT
FOR THE WESTERN DISTRICT OF TEXAS
WACO DIVISION**

KIRSCH RESEARCH AND
DEVELOPMENT, LLC,

Plaintiff,

v.

BLUELINX CORPORATION,

Defendant.

Case No. 6:20-cv-316

JURY TRIAL DEMANDED

**FIRST AMENDED COMPLAINT FOR PATENT INFRINGEMENT
AGAINST BLUELINX CORPORATION**

1. Plaintiff Kirsch Research and Development, LLC (“Kirsch” or “Plaintiff”) files this First Amended Complaint against Defendant BlueLinx Corporation (“BlueLinx” or “Defendant”), and alleges as follows:

NATURE OF THE ACTION

2. This is a civil action for infringement under the patent laws of the United States, 35 U.S.C. § 1, *et seq.*

3. The United States Patent and Trademark Office duly and legally issued U.S. Patent No. 6,308,482 (“the ’482 Patent”) on October 30, 2001. Kirsch is the legal owner of the ’482 Patent by assignment. A true and correct copy of the ’482 Patent is attached hereto as Exhibit 1.

4. The United States Patent and Trademark Office duly and legally issued U.S. Patent No. 8,765,251 (“the ’251 Patent”) on July 1, 2014. Kirsch is the legal owner of the ’251 Patent by assignment. A true and correct copy of the ’251 Patent is attached hereto as Exhibit 2.

5. Defendant has infringed and continues to infringe one or more claims of each of the ’482 Patent and the ’251 Patent (collectively, the “Asserted Patents”) at least by making, using,

importing, selling, and/or offering to sell certain synthetic roofing underlayment products. Kirsch seeks, among other things, monetary damages and injunctive relief.

THE PARTIES

6. Plaintiff Kirsch Research and Development, LLC, is a limited liability corporation organized and existing under the laws of the State of California with its principal place of business at 1296 Patricia Avenue, Simi Valley, California 93065.

7. Defendant BlueLinx Corporation is a corporation organized and existing under the laws of the State of Georgia with its principal place of business at 1950 Spectrum Circle, Suite 300, Marietta, Georgia, 30067.

JURISDICTION AND VENUE

8. This Court has subject matter jurisdiction over Kirsch's claims for patent infringement pursuant to 28 U.S.C. §§ 1331 and 1338(a).

9. Defendant is subject to this Court's personal jurisdiction because Defendant has committed acts within this District giving rise to this action, and has established minimum contacts with this forum such that the exercise of jurisdiction over Defendant would not offend traditional notions of fair play and substantial justice. Defendant, directly and through subsidiaries or intermediaries, has committed and continues to commit acts of infringement in this District by, among other things, making, using, importing, offering to sell, and selling products that infringe the Asserted Patents.

10. Venue is proper in this District under 28 U.S.C. §§ 1391(b) and 1400(b) because upon information and belief, Defendant has transacted business in this District and has committed acts of direct and indirect infringement in this District by, among other things, importing, offering to sell, and selling products that infringe the Asserted Patent. Defendant has a regular and

established place of business in the District, including an office at 6990 Market Street, El Paso, Texas 79915. *See* Ex. 6.

FACTUAL ALLEGATIONS

A. Background of Roofing Underlayment

11. As explained in the Asserted Patents, sloped roofs typically include three main components: a roof support deck, an underlayment, and an overlayment. Figure 5 from the specification of the '482 Patent illustrates these basic components.

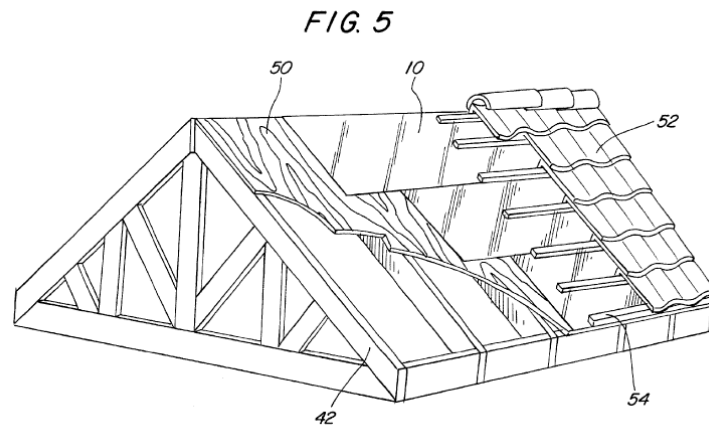

12. The roof support deck (50) provides support and stability for the roof and is typically made of either solid wooden sheathing, such as plywood, oriented strand board, similar to particle board (“OSB”), or spaced sheathing installed over the rafter beams. The overlayment (52) is the outermost layer of the roof and provides protection from weather conditions such as wind, rain, and snowmelt. The overlayment is typically made of shingles, tiles, metal roofing, or other similar materials. The underlayment (10) is sandwiched between the roof support deck (50) and the overlayment (52). The underlayment may also provide an additional waterproof barrier to protect the roof support deck and the interior of the building from moisture or other elements that leak through the overlayment. Ex. 1 at 1:22-29. The underlayment may also form a waterproof

seal so that moisture cannot leak in from around nails or other fasteners used to secure the underlayment or overlayment to the roof support deck. *Id.* at 1:32-34.

13. Roofing underlayment has conventionally been produced by coating organic paper with a layer of asphalt. The market largely consisted of companies who were members in the Asphalt Roofing Manufacturers Association. At one point, this material represented approximately 95% of the pitched roof market (which is generally residential roofs, whereas commercial roofs are generally flat). *Id.* at 1:35-37. This material inevitably resulted in problems because conventional underlayments made of asphalt and paper are not durable against the elements. *Id.* at 1:37-43. For example, over time, moisture tends to accumulate under the overlayment; that moisture causes conventional underlayments to weather and deteriorate. *Id.* Similarly, heat from the sun and the interior of the building causes conventional underlayments to dry out and deteriorate. *Id.* at 1:43-47. The deterioration of the underlayment destroys its ability to function as a waterproof barrier, and the deteriorated underlayment allows moisture to pass through to the roofing support structure, ultimately resulting in roof leaks and damage to the interior of the building. *Id.* at 1:47-50. In some cases, the life of the underlayment is far shorter than the overlayment, with the deleterious effect of the roof outwardly appearing to be sound when it is not.

14. Furthermore, conventional underlayments require the use of a solid support deck, such as plywood, for example. *Id.* at 1:58-61. But when conventional underlayments are used with spaced support structures, their flexible paper tends to drape between the rafters, allowing moisture that gathers under the overlayment to puddle in the draped portions of the underlayment. *Id.* at 1:61-67. The weight of the puddles creates tension on the underlayment in the draped portions and at the points where the underlayment is attached to the rafters, resulting in tearing and leaking. *Id.*

at 1:67-2:5. Conventional underlayment is particularly likely to tear when it is already weakened by exposure to the elements. *Id.* at 2:5-7.

15. A weather-resistant barrier for the underlayment is essential to the integrity of the entire roof structure. *Id.* at 1:50-51. But conventional underlayments often deteriorate much more quickly than the overlayment. *Id.* at 1:51-54. The underlayment therefore often limits the lifespan of the entire roof. *Id.* at 1:55-57. Given that conventional underlayments also require higher labor costs involved in transport and installation, among having other issues, the need existed for a different kind of underlayment material.

B. Kirsch's Innovative Roofing Underlayment Inventions

16. Kirsch was founded by the named inventor of the Asserted Patents, Mark C. Strait, who serves as its Chief Executive Officer. Kirsch's business is focused on commercializing the innovative roofing underlayment solutions claimed in the Asserted Patents. Kirsch is an American-owned and operated developer, manufacturer and distributor of roofing products, which are made in the United States.

17. Mr. Strait has more than 26 years of experience in the roofing and construction business. That experience spans the gamut of the roofing industry, from construction, including decades as a professional roofer, to developing, manufacturing, and selling various roofing related products, including the underlayments that are the subject of this suit, and to founding and leading various trade groups specifically relating to underlayments and roofing. Through his experience, he understood the shortcomings of conventional roof underlayments, which tear easily and are not durable against the elements, and recognized the need for a weather- and tear-resistant underlayment to improve the longevity of roof structures, and which was easier and safer to install.

18. In addition to recognizing such deficiencies in conventional roof underlayments, Mr. Strait's hands-on experience as a professional roofer allowed him to also recognize that changes could be made to underlayments that would improve the installation process. He knew from personal experience that working on roofs posed serious physical risks not only from the sloped roofs that are common with residential buildings, but also from the build-up of construction and natural debris, such as dust, dirt, ceramic granules from asphalt shingles, and other small particles of material, on the underlayment surface as it is being installed, and from fluids, such as rain or dew, all of which may combine to result in a slippery and dangerous surface for workers.

19. The inventions described in the Asserted Patents are aimed at overcoming the shortcomings of conventional roofing underlayments. The Asserted Patents describe different forms of reinforced roofing underlayments with improved resistance to deterioration from the elements, improved tensile strength to resist tearing, and additional features that improved safety and installation, ultimately resulting in a more durable, reliable, and safer weather-resistant barrier. Ex. 1 at 2:21-27, 4:23-32.

1. The '482 Patent

20. The '482 Patent, in one embodiment, describes a reinforced roofing underlayment that has a woven synthetic scrim, coated on at least one side by a layer of thermoplastic material. *Id.* at 2:34-37. This scrim is made of interwoven strands that are strong enough to resist tearing in various directions. *Id.* at 2:37-40. The thermoplastic layer or layers provide a weather-resistant barrier to prevent moisture from passing through the underlayment to the roofing support structure and the interior of the building. *Id.* at 2:40-44. The coating material is preferably a layer of thermoplastic film which may be coextruded over both sides of the scrim. *Id.* at 2:44-46.

21. Figure 1 from the specification of the '482 Patent shows an exploded perspective view of an exemplary embodiment of the invention.

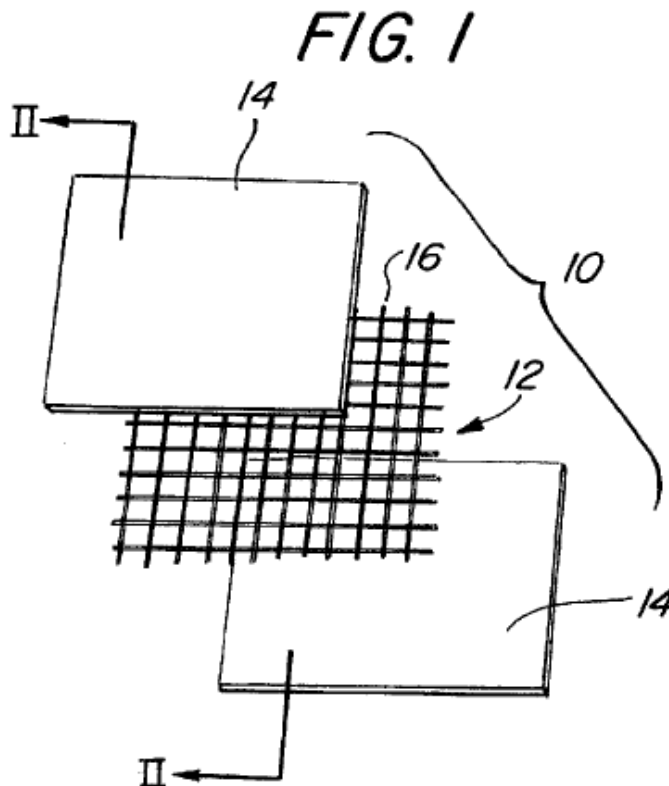

22. In Figure 1, the underlayment (10) includes a reinforcing scrim (12) consisting of a mesh of individual, interwoven strands (16). The scrim (12) has a layer of thermoplastic material affixed to at least one of its sides; the preferred embodiment depicted in Figure 1 has layers of waterproof material (14) affixed to both sides of the scrim (12).

23. The interwoven strands (16) that make up the scrim (12) are preferably made of a thermoplastic polymer such as polypropylene, polyethylene, polyester, nylon, or other similar synthetic material. *Id.* at 3:49-52.

24. The coating material (14) affixed to the scrim (12) is preferably a layer of thermoplastic film extruded over each side of the scrim (12), so that the reinforcing scrim is sandwiched between the two layers. *Id.* at 3:66-4:3.

25. The invention as shown in a preferred embodiment in Figure 1 results in a weather-resistant roofing underlayment that resists deterioration from the elements and that can withstand tensile loads from various directions without tearing. *Id.* at 3:45-49.

26. Figure 2 of the specification of the '482 Patent shows a cross-sectional view of a preferred embodiment of the invention.

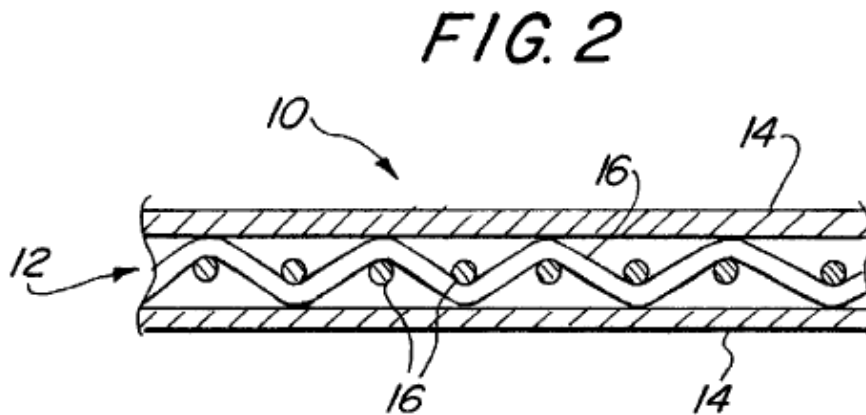

27. As shown in Figure 2, the individual strands (16) that make up the reinforcing scrim (12) are interwoven. Figure 2 depicts the individual strands (16) as round, but the patent explains that they may be any cross-sectional shape or size, depending on the desired characteristics of the scrim (12). *Id.* at 3:57-59.

28. In addition to the woven synthetic scrim and the coating layer or layers, the claimed roofing underlayment may also include a slip-resistant outer surface to let roofers walk on the roofing underlayment without slipping during installation. *Id.* at 2:50-54.

29. Figure 3 depicts a preferred embodiment of the claimed roofing underlayment (10) with a reinforcing scrim (12) with a layer of coating material (14) on either side.

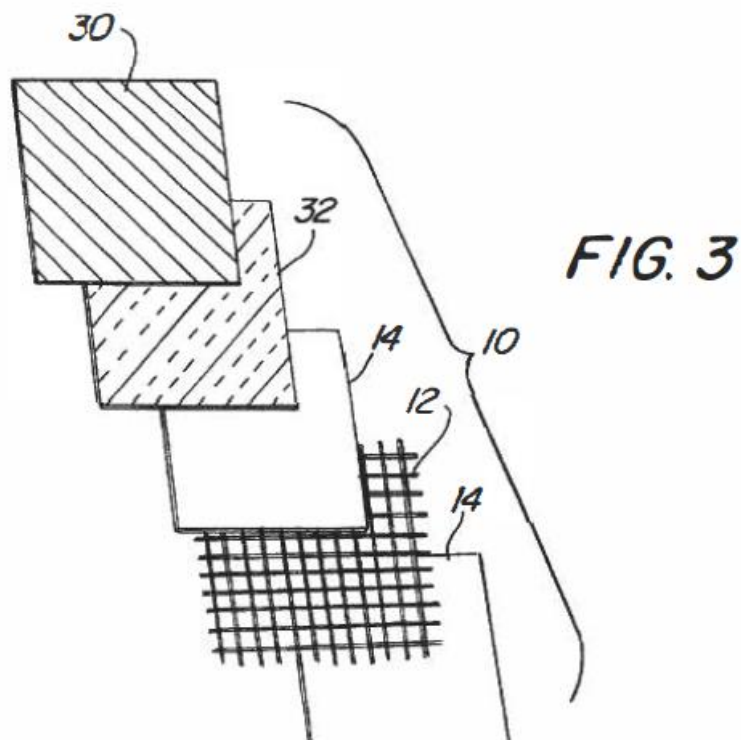

30. In addition, Figure 3 depicts a slip-resistant surface layer (30) positioned over the surface of the underlayment. The slip-resistant layer (30) prevents roofers and other workers from slipping when moving about on the underlayment. *Id.* at 4:23-27. The slip-resistant layer (30) is preferably formed of non-woven polypropylene, which remains slip-resistant while either wet or dry, but any slip-resistant material can be used. *See id.* at 4:28-32.

31. The preferred embodiment in Figure 3 also depicts a radiant barrier layer (32) that reflects solar energy and therefore reduces the transmission of radiant heat through the roofing underlayment (10). *Id.* at 4:33-36. Reducing the transmission of radiant heat can reduce the energy costs for cooling the interior of the building; it can also improve the fire resistance of the roofing underlayment (10). *See id.* at 4:53-57. The radiant barrier layer (32) is preferably a metalized material, such as aluminum foil. *Id.* at 4:36-38. Figure 3 depicts the radiant barrier layer (32) as

positioned between the nonslip surface (30) and a thermoplastic layer (14), but the radiant barrier layer (32) may be positioned at any point within the roofing underlayment (10) other than between two thermoplastic layers (14), where the radiant barrier layer (32) could act as a conductor. *Id.* at 4:43-47.

32. The invention can be used with any kind of roof support, including spaced roof support structures, such as rafters, or solid roof support decks. Figure 4A illustrates the claimed underlayment (10) being draped over and affixed to rafters (42).

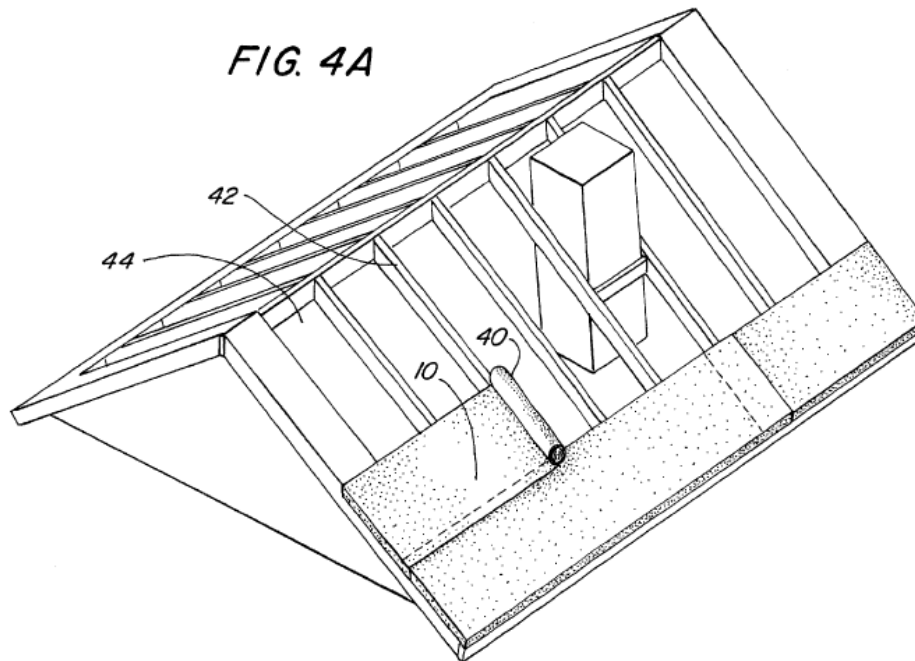

33. As shown in Figure 5, supra ¶ **Error! Reference source not found.**, the underlayment (10) may also be used with a solid roof support deck (50).

2. The '251 Patent

34. The '251 Patent describes a reinforced roofing underlayment that specifically has a top layer of non-woven spun-bond polypropylene fabric, and a waterproof bottom structural layer laminated to the top layer. Ex. 2 at 9:26-30. The waterproof bottom structural layer includes a

woven polypropylene scrim and a polypropylene coating that is applied as a liquid to saturate the scrim and bond the scrim to the non-woven top layer. *Id.* at 9:30-33. The top layer is pressed into the polypropylene coating of the bottom structural layer to form a micro-textured surface. *Id.* at 9:33-36.

35. Figure 1 of the specification of the '251 Patent shows a cross-sectional view of a preferred embodiment of the invention.

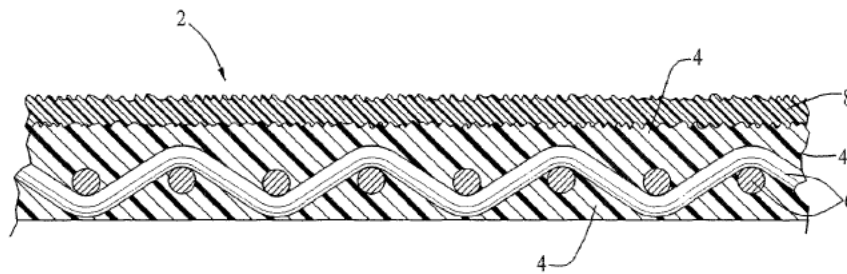

Fig. 1

36. Ex. 2 at Fig. 1. In particular, Figure 1 depicts an enlarged, cross-sectional view of a slip-resistant roofing underlayment embodiment of the invention. *Id.* at 3:8-10, 3:39-41. The roofing underlayment includes a scrim (6) woven from polypropylene fibers or tapes, a top layer (8) made from a non-woven polypropylene fabric (spun-bond polypropylene), and a polypropylene coating (4) applied between the scrim (6) and the top layer (8) so as to bond the scrim and the top layer together. *Id.* at 3:41-46.

37. The non-woven fibers of the spun-bond top layer (8) provide improved traction and slip-resistance, even when exposed to moisture or when covered with debris. *Id.* at 3:60-64. In addition, pressing the non-woven top layer into the coating layer inhibits the fibers in the non-woven top layer from “pencil rolling” or pulling away from the surface of the roof underlayment,

which contributes to the micro-textured surface, thereby improving traction and slip-resistance. *See, e.g., id.* at 1:55-61.

38. Due to the structure and composition of the claimed underlayment of the '251 Patent, the underlayment is also resistant to thermal expansion or contraction, wrinkling, absorbing moisture, scarring, or melting. *Id.* at 3:65-67. It can withstand high temperatures without softening, and may also be ultraviolet resistant and contain antioxidants for even longer-term resistance to heat cycling and other environmental factors. *Id.* at 3:67-4:3. It also resists rotting, drying out, or becoming brittle. *Id.* at 4:3-4. The underlayment also provides added protection against high winds and hail. *Id.* at 4:4-5. And the underlayment is light in weight. *Id.* at 4:5-7.

39. The '251 Patent also describes manufacturing several embodiments of the invention by an extrusion lamination process, which, among other things, improves the bonding between the layers of the underlayment, thereby reducing the chances of delamination while improving shear strength, abrasion resistance, lay-flat quality, and slip-resistance. *Id.* at 1:59-2:2, 2:19-22.

40. Figure 2 of the specification of the '251 Patent is a diagram of a laminating apparatus used in forming a slip-resistant roofing underlayment embodiment of the invention.

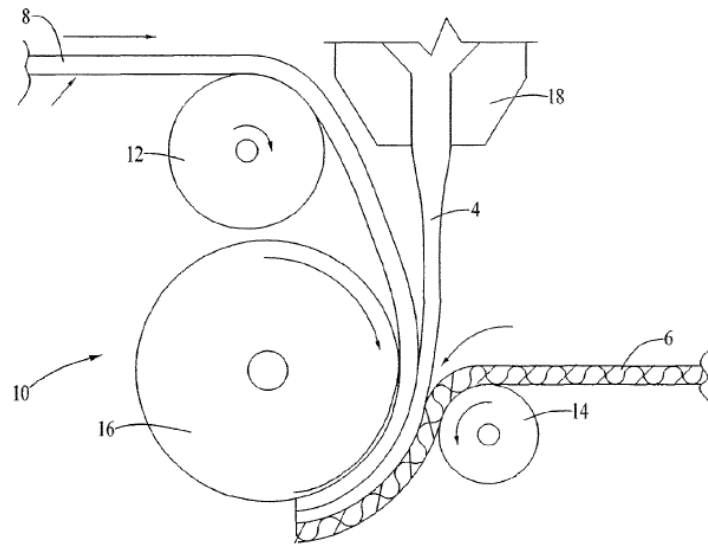

FIG. 2

41. In Figure 2, the lamination apparatus (10) includes a pair of master rolls (not shown) containing a rolled sheet of the scrim material (6) and a rolled sheet of the top layer fabric (8). The top layer fabric (8) is passed over a guide roller (12) and then into a lamination nip sequence formed between a nip roller (14) and a chill roller (16), while the coating (4) is being extruded (in a liquid state) from an extruder (18) and between the layers (6) and (8). Specifically, the top layer fabric (8) is laminated to the scrim fabric (6) as the extruded coating (4) is applied between the top layer fabric (8) and the scrim fabric (6) as the fabrics pass between the nip roller (14) and the chill roller (16). As the scrim fabric (6), the molten polypropylene coating (4), and the top layer fabric (8) pass between the nip roller (14) and the chill roller (16), the scrim fabric (6) and the top layer fabric (8) are pressed together, causing the polypropylene coating (4) to be impregnated into the woven fabric of the scrim (6) at the same time that the top layer fabric (8) is being laminated to the scrim (6). *See id.* at 4:8-34.

42. The '251 Patent also describes other improvements to conventional underlayments, including the addition of a second polypropylene coating on the bottom surface of the bottom

structural layer to further increase durability. The '251 Patent also describes the use of an array of guidelines, including overlap, outer layout, and inner layout guidelines, printed on the top layer to improve the ease of installing, and correctly installing, the underlayment. *Id.* at 4:63-6:4, 7:26-44.

43. The specific limitations represent a significant improvement over conventional roofing underlayments. Ex. 1 at 5:46-50. The thermoplastic layers of the claimed underlayment improve the underlayment's resistance to deterioration from exposure to moisture and other elements. *Id.* at 5:53-59. The reinforcing scrim provides the claimed invention with improved tensile strength to resist tearing from external forces such as puddled moisture and wind. *Id.* at 5:62-65. These improvements over conventional roofing underlayments result in improvements to the longevity and integrity of the entire roof structure. *Id.* at 5:65-6:7. And the slip-resistant layer provides improvements in ease of use and installation, and, importantly, the safety of individuals installing the roofs, and anyone working on the roofs. *Id.* at 4:23-32; *see also* Ex. 2 at 3:65-4:7.

C. Kirsch's Patented Products

44. Kirsch's products are made in the United States. Through its licensee, Kirsch Building Products, LLC, Kirsch manufactures and sells its own patented roof underlayment products, including Sharkskin Comp, Sharkskin Ultra, Sharkskin Ultra SA, and Sharkskin Ultra Radiant. *See* <https://sharkskinroof.com/sharkskin-products/>.

45. Kirsch's products employ the patented technology in various embodiments, including a self-adhesive underlayment (Sharkskin Ultra SA) and an underlayment with a metalized radiant layer (Sharkskin Ultra Radiant).

46. The commercial utility of Kirsch's invention is reflected in customers' satisfaction with Kirsch's products. Customers are "very happy with the results" obtained by using Kirsch's patented products. *See* <https://sharkskinroof.com/sharkskin-testimonials/>. One customer described

how Sharkskin Ultra underlayment “protected a hand-crafted timber-frame home from the extremes of northern Rocky Mountain weather” for eighteen months without being covered by overlayment, preventing a single leak even from 17 inches of heavy, wet, melting snow. *See id.*

47. Pursuant to 35 U.S.C. § 287, Kirsch has given notice to the public that its products are patented by marking its patented products with the '482 Patent. Beginning in or around 2003, Kirsch marked its Sharkskin-branded products with the number of the '482 Patent. Among other things, Kirsch has marked its products themselves as well as product and marketing literature. These products have been continuously marked by Kirsch since this time.

48. Kirsch has also given notice to the public that its products are patented by marking its patented products with the '251 Patent. Beginning in or around late 2014, Kirsch marked its Sharkskin-branded products with the numbers of the '251 Patent. Among other things, Kirsch has marked its products themselves as well as product and marketing literature. These products have been continuously marked by Kirsch since this time.

D. Defendant’s Knowledge Of The Asserted Patents

49. The synthetic underlayment market is relatively small. Kirsch is a well-respected pioneer in the market and, over the last two decades, has manufactured and sold quality products made in the United States. Kirsch was one of the first businesses in the United States to sell synthetic underlayment products and helped to pioneer the industry in the United States.

50. Since at least the introduction of Defendant’s accused products, Kirsch and Defendant have been direct competitors in the synthetic underlayment market. Given Kirsch’s long-time presence in the market and regular advertising efforts, Kirsch’s products are well-known in the industry. Similarly, given that the products and related literature are consistently and

prominently marked, on information and belief, the Asserted Patents are also well-known within the industry.

51. Kirsch attends approximately 6 to 10 trade shows on average a year. Typically, at least Mark C. Strait attends on behalf of Kirsch and personally staffs his company's booths at the shows. Mr. Strait is actively involved at such shows and has become associated with Kirsch at industry shows.

52. At each show, Kirsch brings product literature and product samples that are marked with the numbers of Kirsch's patents. In addition, it conducts various product demonstrations at such shows. Kirsch's product literature and product samples have been marked with the numbers of the '482 Patent since around 2003. The product literature and product samples have been marked with the numbers of the '251 Patent since around late 2014.

53. It is typical at trade shows for competitors to visit each other's booths and obtain information about the competing products. On information and belief, Defendant may have obtained and studied Kirsch's marked materials as a result of its trade show presence.

54. On information and belief, Defendant also learned of the '482 Patent and the '251 Patent as a result of Kirsch's marked products and literature through Defendant's competition with Kirsch and Kirsch's presence at trade shows.

COUNT I

INFRINGEMENT OF PATENT NO. 6,308,482

55. Kirsch realleges and incorporates by reference the foregoing paragraphs as if fully set forth herein.

56. On information and belief, Defendant makes, uses, offers for sale, sells, and/or imports certain products ("Accused Products"), such as the ProLinx line of synthetic underlayment

products, including ProLinx UDL 10, ProLinx UDL 20, and ProLinx UDL 30, and other synthetic underlayment products it sells on behalf of third party manufacturers, that directly infringe, literally and/or under the doctrine of equivalents, at least claims 1 and 2 of the '482 Patent.

57. Defendant also knowingly and intentionally induces infringement of at least claims 1 and 2 of the '482 Patent in violation of 35 U.S.C. § 271(b). As described above, Defendant has been aware of the '482 Patent since at least the introduction of the Accused Products, when Defendant began competing with Kirsch and became aware of Kirsch's competing products and related literature, all of which were marked with the '482 Patent. Defendant's products are very similar (though of lesser quality) in relevant aspects to Kirsch's products. At the very least, Defendant has been willfully blind to its infringement of the '482 Patent by, for example, disregarding its knowledge of the '482 Patent, and ignoring the patent markings on both Kirsch's practicing products and its literature. Despite this knowledge of the '482 Patent, Defendant continues to actively encourage and instruct its customers and end users (for example, through its installation guides, product information and specification sheets, or online instruction materials on its website) to use the Accused Products in ways that directly infringe the '482 Patent. Defendant does so knowing and intending that its customers and end users will commit these infringing acts. Defendant also continues to import, sell for importation, and/or sell in the United States the Accused Products, despite its knowledge of the '482 Patent, thereby specifically intending for and inducing its customers to infringe the '482 Patent through the customers' normal and customary use of the Accused Products.

58. A claim chart comparing claims 1 and 2 of the '482 Patent to a representative Accused Product, ProLinx UDL 10, and including photographs and drawings where applicable, is attached as Exhibit 3.

59. By making, using, offering for sale, selling and/or importing into the United States the Accused Products, Defendant has injured Kirsch and is liable for infringement of the '482 Patent pursuant to 35 U.S.C. § 271.

60. As a result of Defendant's infringement of the '482 Patent, Kirsch is entitled to monetary damages in an amount adequate to compensate for Defendant's infringement, but in no event less than a reasonable royalty for the use made of the invention by Defendant, together with interest and costs as fixed by the Court.

61. Defendant has infringed the '482 Patent, acting with objectively high likelihood that its actions constitute infringement of the '482 Patent. Defendant has known or should have known of this risk at least as early as the release of the Accused Products. Accordingly, Defendant's infringement of the '482 Patent has been willful.

62. Defendant's infringement of the '482 Patent is exceptional and entitles Kirsch to attorney's fees and costs pursuant to 35 U.S.C. § 285.

COUNT II

INFRINGEMENT OF PATENT NO. 8,765,251

63. Kirsch realleges and incorporates by reference the foregoing paragraphs as if fully set forth herein.

64. On information and belief, Defendant makes, uses, offers for sale, sells, and/or imports certain Accused Products (the "Accused Products"), such as the ProLinx line of synthetic underlayment products, including ProLinx UDL 10, ProLinx UDL 20, and ProLinx UDL 30, and Owens Corning's RhinoRoof line of synthetic underlayment products, including RhinoRoof U10, RhinoRoof U15, RhinoRoof U20, and RhinoRoof RSA, that directly infringe, literally and/or under the doctrine of equivalents, at least claims 1 and 11 of the '251 Patent.

65. Defendant also knowingly and intentionally induces infringement of at least claims 1 and 11 of the '251 Patent in violation of 35 U.S.C. § 271(b). As described above, Defendant has been aware of the '251 Patent since at least it began to be marked on Kirsch's products and literature in or around late 2014. Defendant's products are very similar (though of lesser quality) in relevant aspects to Kirsch's products. At the very least, Defendant has been willfully blind to its infringement of the '251 Patent by, for example, disregarding its knowledge of the '251 Patent, and ignoring the patent markings on both Kirsch's practicing products and its literature. Despite this knowledge of the '251 Patent, Defendant continues to actively encourage and instruct its customers and end users (for example, through its installation guides, product information and specification sheets, or online instruction materials on its website) to use the Accused Products in ways that directly infringe the '251 Patent. Defendant does so knowing and intending that its customers and end users will commit these infringing acts. Defendant also continues to import, sell for importation, and/or sell in the United States the Accused Products, despite its knowledge of the '251 Patent, thereby specifically intending for and inducing its customers to infringe the '251 Patent through the customers' normal and customary use of the Accused Products.

66. A claim chart comparing claims 1 and 11 of the '251 Patent to a representative Accused Product, RhinoRoof U20, and including photographs and drawings where applicable, is attached as Exhibit 4. A claim chart comparing claims 1 and 11 of the '251 Patent to a representative Accused Product, ProLinx UDL 30 is attached as Exhibit 5.

67. By making, using, offering for sale, selling and/or importing into the United States the Accused Products, Defendant has injured Kirsch and is liable for infringement of the '251 Patent pursuant to 35 U.S.C. § 271.

68. As a result of Defendant's infringement of the '251 Patent, Kirsch is entitled to monetary damages in an amount adequate to compensate for Defendant's infringement, but in no event less than a reasonable royalty for the use made of the invention by Defendant, together with interest and costs as fixed by the Court.

69. Defendant has infringed the '251 Patent, acting with objectively high likelihood that its actions constitute infringement of the '251 Patent. Defendant has known or should have known of this risk at least as early as the release of the Accused Products, and no later than the filing of this complaint. Accordingly, Defendant's infringement of the '251 Patent has been and continues to be willful.

70. Defendant's infringement of the '251 Patent is exceptional and entitles Kirsch to attorney's fees and costs pursuant to 35 U.S.C. § 285.

PRAYER FOR RELIEF

WHEREFORE, Plaintiff Kirsch respectfully requests the following relief:

1. Judgment in Kirsch's favor and against Defendant on all causes of action alleged herein;
2. An award of damages to Kirsch in an amount to be further proven at trial;
3. Preliminary and permanent injunctive relief against Defendant as to the '251 Patent;
4. A finding that this case is exceptional under 35 U.S.C. § 285 and that Kirsch should be awarded its attorney's fees;
5. An award of enhanced damages to Kirsch as a result of Defendant's willful infringement;
6. An award of prejudgment and post-judgment interest, costs and other expenses; and
7. Such other and further relief as the Court may deem to be just and proper.

DEMAND FOR A JURY TRIAL

Kirsch hereby demands a jury trial for all causes of action, claims, or issues in this action that are triable as a matter of right to a jury.

Dated: August 11, 2020

Respectfully submitted,

RUSS, AUGUST & KABAT

By: */s/ Benjamin T. Wang*
Benjamin T. Wang (CA Bar No. 228712)
Marc A. Fenster (CA Bar No. 181067)
Amy E. Hayden (CA Bar No. 287026)
Theresa M. Troupson (CA Bar No. 301215)
Jonathan Ma (CA Bar No. 312773)
RUSS, AUGUST & KABAT
12424 Wilshire Boulevard, 12th Floor
Los Angeles, California 90025
Telephone: (310) 826-7474
Facsimile: (310) 826-6991
Email: **wang@raklaw.com**
 mfenster@raklaw.com
 ahayden@raklaw.com
 ttroupson@raklaw.com
 jma@raklaw.com

Elizabeth L. DeRieux
State Bar No. 05770585
Capshaw DeRieux, LLP
114 E. Commerce Ave.
Gladewater, TX 75647
Telephone: (903) 845-5770
Email: **ederieux@capshawlaw.com**

Matthew D. Aichele
Russ August & Kabat
800 Main Avenue, SW, Suite 200
Washington, DC 20024
Phone: (202) 664-0623

RINCON VENTURE LAW GROUP
K. Andrew Kent (CA Bar No. 130097)
2801 Townsgate Road, Suite 200
Westlake Village, CA 91361
Telephone: (805) 557-0580
Facsimile: (805) 557-0480
Email: **akent@rincongroup.com**
Attorneys for Plaintiff
Kirsch Research and Development, LLC