

**IN THE UNITED STATES DISTRICT COURT  
FOR THE WESTERN DISTRICT OF TEXAS  
WACO DIVISION**

---

AKURATE DYNAMICS, LLC,

Plaintiff,

v.

CARLISLE FLUID TECHNOLOGIES, INC.,

Defendant.

---

:  
:  
:  
: Civil Action No. 6:20-cv-00606 ADA  
:  
: JURY TRIAL DEMANDED  
:  
:  
:  
:  
:  
:

**FIRST AMENDED COMPLAINT**

Plaintiff, Akurate Dynamics, LLC (“Akurate”), by its counsel, files this First Amended Complaint against Defendant, Carlisle Fluid Technologies, Inc. (“Carlisle Fluid”), and in support thereof avers as follows:

**INTRODUCTION**

1. Akurate brings this action against Carlisle Fluid for patent infringement, trade secret misappropriation, breach of contract, and unjust enrichment to protect Akurate’s rights and investments in its intellectual property, including U.S. Patent No. 10,159,996 (“the ‘996 Patent,” attached as **Exhibit A**).

2. Akurate, based in Houston, is engaged in the business of engineering and manufacturing equipment designed to work in the spray polyurethane and polyurea plastics markets, such as spray foam insulation. Spray foam is a mixture of various plastic foam materials that can be used to insulate buildings and homes. It has various advantages over traditional insulation, including easier application and a higher degree of insulation. In the spray foam insulation process, spray foam is sprayed from a chemical processing machine on to a target surface, such as walls and roof decks. At the point of application, i.e. right as the spray

foam exits the machine’s spray gun, the various chemicals that constitute the spray foam must be mixed at a very precise ratio. Due to the constantly changing nature of the chemicals involved, the spray foam technology over the last 30 years has struggled to mix chemicals in real time and achieve the required ratio at the point of application. This difficulty is significant because failure to achieve the required ratio results in shrinkage of the spray foam or extreme and unpleasant odors. Akurate spent almost ten years creating a dynamic, auto-adjusting system for the spray application of multiple component liquid compounds that are mixed at the point of spray application to release the spray foam insulation at the desired ratio. Akurate’s system corrected the known deficiencies with traditional spray foam systems by exerting very precise control over the volume and/or mass flow rate of several liquid chemicals to achieve and maintain a desired ratio of mixing at the point of spray application. To Akurate’s knowledge, there is no other independently created spray foam technology that can achieve as much control at the point of spray application as Akurate’s system.

3. REDACTED

[REDACTED]

[REDACTED]

[REDACTED]

[REDACTED]

[REDACTED]

[REDACTED]

[REDACTED]

[REDACTED]

[REDACTED] During this time, Akurate learned from industry sources that Carlisle Fluid

was rumored to be developing a spray foam system. In February 2020, at the annual Spray Polyurethane Foam Alliance (“SPFA”) convention in California, Akurate learned that Carlisle Fluid had developed and was advertising a spray foam system that functions nearly identically to Akurate’s spray foam system (hereafter “the Accused System”). Further, Akurate learned that the Accused System uses gear pumps and flow meters from the same German manufacturer that Akurate uses. This information was confidential to Akurate and key to the success of its spray foam system **REDACTED**

**REDACTED**

4. Additionally, Carlisle Fluid prepared and filed its own provisional patent application on a spray foam machine in July 2017, **REDACTED**; this patent application, which is still pending, discloses technology that was invented by Akurate and also technology that is covered by the claims of Akurate’s ’996 Patent.

5. Upon information and belief, Carlisle Fluid misappropriated Akurate’s confidential and trade secret information **REDACTED** **REDACTED** Carlisle Fluid had access to and learned about Akurate’s confidential information, trade secrets, and patented spray foam technology. Based on Akurate’s more than nine years in the industry, Carlisle Fluid could not have developed the Accused System, which is nearly identical to Akurate’s spray foam equipment, in such a short amount of time without the benefit and use of Akurate’s intellectual property. Upon information and belief, Carlisle Fluid unlawfully copied Akurate’s confidential information, trade secrets, and patented system in order to create its own spray foam equipment manufacturing business and compete against Akurate. Carlisle Fluid’s unlawful conduct threatens the loss of a significant portion of Akurate’s revenue, along with its goodwill, reputation, and market share. Akurate comes before

this Court seeking equitable injunctive relief and damages, to put a stop to Carlisle Fluid's patent infringement, theft of trade secrets, breach of contract, and unjust enrichment.

**PARTIES**

6. Plaintiff Akurate is a Texas limited liability company with headquarters located at 7618 Bluff Point Drive, Houston, Texas 77086.

7. Defendant Carlisle Fluid is a Delaware corporation with a headquarters located at 16430 N. Scottsdale Road, Suite 450, Scottsdale, Arizona 85254.

**JURISDICTION AND VENUE**

8. This Court has original jurisdiction under 28 U.S.C. §§ 1331, 1332(a)(1) and 1338. This is a dispute arising under the laws of the United States, including the Defend Trade Secrets Act ("DTSA"), 18 U.S.C. § 1836 *et seq.*, and the United States Patent Act, 35 U.S.C. § 1 *et seq.* Further, the amount in controversy exceeds the sum or value of \$75,000.00, exclusive of interest and costs, and is between citizens of different states.

9. This Court has personal jurisdiction over Carlisle Fluid. Upon information and belief, Carlisle Fluid conducts business in the State of Texas. Carlisle has a place of business in Dallas, Texas. Carlisle Fluid personnel travel throughout Texas marketing and selling devices, including the Accused System. The claims herein arise out of Carlisle Fluid's activities in Texas, including its attempts to sell the Accused System in the Western District of Texas.

10. Venue is proper in this Court under 28 U.S.C. § 1391(b)(2) because a substantial portion of the events giving rise to the causes of action described herein occurred in the Western District of Texas. Upon information and belief, Carlisle Fluid is promoting, using, demonstrating, and offering for sale the Accused System in the Western District of Texas, including in at least Austin, Texas **REDACTED**, a

misappropriation of Akurate's trade secret/confidential information, and an infringement of the '996 Patent. Carlisle's patent infringement claim arises from a common nucleus of operative facts as the core claims in this action—REDACTED

**A. 2013-2016: Akurate Becomes A Leading Innovator in Spray Polyurethane Processing Technology.**

11. Akurate was formed in 2011 in Houston, Texas by Trey Cook and Charlie McAndrew to enter into the spray foam insulation market. In its initial years, Akurate was solely an operating company, applying spray foam insulation to houses and buildings. During that time, Mr. Cook and Mr. McAndrew recognized that a longstanding and unaddressed problem with most spray foam delivery systems was their inability to achieve the required ratio of chemicals and, as a result, avoid shrinkage and odorous off gassing of the spray foam. Mr. Cook and Mr. McAndrew realized they could use their extensive knowledge of fluid dynamics, gained from careers in the oil and gas industry, to create a system to address this deficiency.

12. In 2013, Akurate began designing its own spray polyurethane processing system. In 2015, Akurate started building a spray system that uses pumps in a primary-secondary configuration (commonly known in the art as a "master-slave" configuration): instead of both pumps being controlled by the motor, the primary pump would receive feedback from sensors and automatically adjust the speed of the secondary pump. Flow meters are coupled to the primary-secondary pumps which, in conjunction with pressure sensors, result in precise control over the volume and/or mass flow rate of several liquid chemicals being delivered from the pumps, ultimately achieving precise control over the ratio of chemicals mixed at the point of

spray application. Below is a schematic showing how chemicals move into the Akurate spray system and are regulated by a heating unit and a flow pump (controlled by the embedded software) before being released from the spray gun:

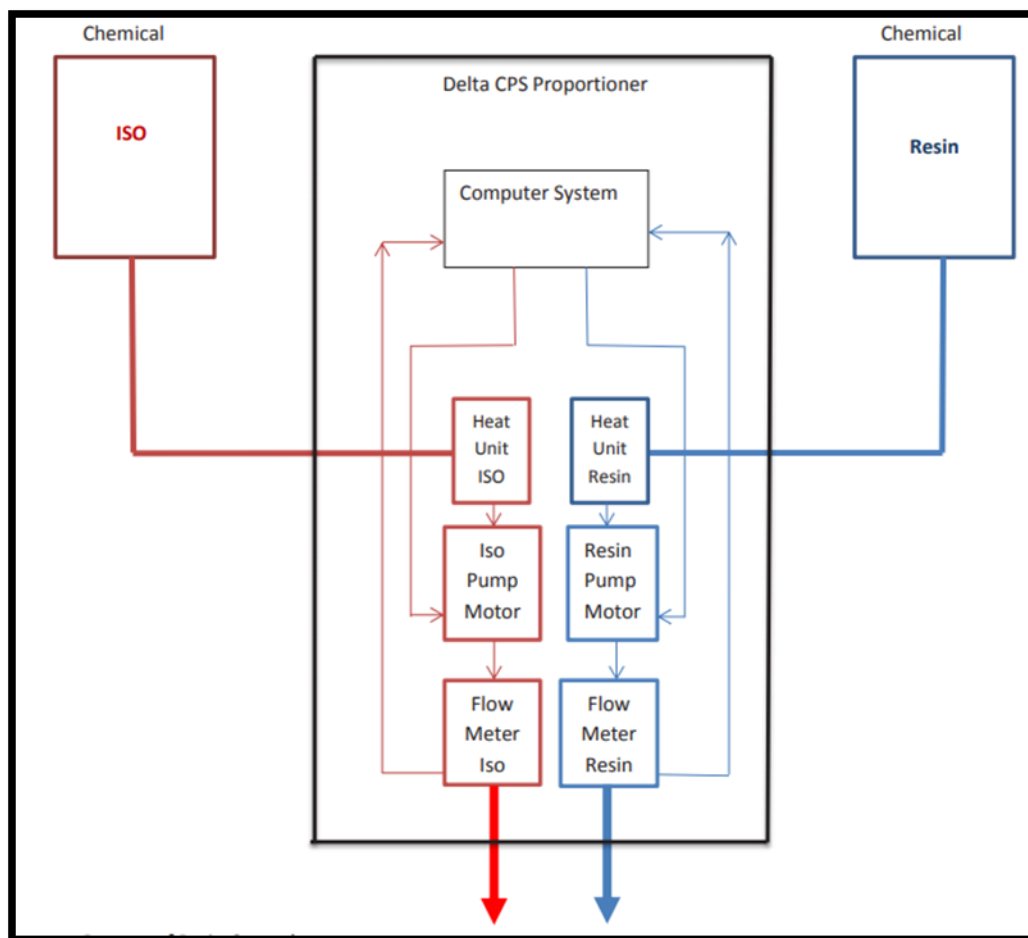

As seen in the above schematic, a flow meter near the pump output reads the amount of each chemical being released; this allows a primary pump to adjust the flow of the chemicals to ensure the desired ratio is consistently achieved at the point of spray application.

13. After successful field trials of the primary-secondary system in 2015, Akurate set out in 2016 to complete development of the system for commercial sale.

14. Akurate's system achieves a higher quality of spray polyurethane foam and increased cost efficiency in the manufacturing process and cost savings for the consumer.

Additionally, Akurate's system maximizes chemical yield and is more efficient and cost effective because both the equipment and the chemicals can be heated more quickly than is possible with more standard equipment. The image on the bottom left shows Akurate's patented system, and the image on the bottom right shows the internal components of the system:



**B. 2016-2019: Akurate Gives Carlisle Fluid Access to its Trade Secrets, Confidential Information, and Patented Technology Pursuant to the Carlisle NDA.**

15. Carlisle Fluid is one of several global companies that are part of Carlisle Companies Incorporated. Carlisle Fluid is in the business of manufacturing equipment used in the application of various coatings and bonding materials.<sup>1</sup> In 2019, Carlisle Fluid had a revenue of \$278.4M and operating income of \$24M.<sup>2</sup>

<sup>1</sup> See Carlisle Fluid Technologies, "About Us," available at <https://www.carlisleleft.com/information/about-us-usa> (last accessed Aug. 12, 2020).

<sup>2</sup> See Carlisle Fluid Technologies, "ESG Annual Report 2019," available at [https://s22.q4cdn.com/386734942/files/doc\\_financials/2019/ar/21799-1\\_CAR\\_AR2020\\_Digital150\\_FINAL.pdf](https://s22.q4cdn.com/386734942/files/doc_financials/2019/ar/21799-1_CAR_AR2020_Digital150_FINAL.pdf) (last accessed Aug. 12, 2020).

16. REDACTED

[REDACTED]

[REDACTED]

[REDACTED]

[REDACTED]

[REDACTED]

[REDACTED]

[REDACTED]

[REDACTED]

[REDACTED]

[REDACTED]

[REDACTED]

[REDACTED]

[REDACTED]

[REDACTED]

[REDACTED]

[REDACTED]

[REDACTED]

REDACTED

[REDACTED]

[REDACTED]

17. REDACTED

[REDACTED]



REDACTED

[REDACTED]

[REDACTED]

[REDACTED]

[REDACTED]

18. REDACTED

[REDACTED]

[REDACTED] This information included its spray applicator system and methodologies, including the primary-secondary pump configuration, the characteristics of components used in the system, like temperature sensors, flow sensors, pressure sensors, pumps, hoses, and heaters, where those components are positioned in the system, the benefits of that positioning including unique data output, and how that unique data is interpreted and used by the embedded software logic to achieve dynamic flow-control. REDACTED

[REDACTED]

[REDACTED]

[REDACTED] REDACTED

[REDACTED] This trade secret and/or confidential information is hereafter referred to as “Akurate’s Trade Secret/Confidential Information.”

19. REDACTED

[REDACTED]

[REDACTED]

[REDACTED]

20. On June 5, 2017, Akurate made the first commercial sale of its spray foam system.

21. On July 21, 2017, REDACTED

REDACTED

REDACTED Carlisle Fluid filed a provisional patent application (U.S. Patent App. No. 62/535,817) entitled “Systems and Methods for Improved Control of Impingement Mixing.” The named inventor of this application is Eric Julius Donaldson, the Vice President of Research and Development at Motion Tech Automation (“Motion Tech”), a product development and design company in the field of motion control.<sup>3</sup> Upon information and belief, Carlisle Fluid would later hire Motion Tech to design its infringing system using Akurate’s Trade Secret/Confidential Information. Carlisle’s patent application disclosed Akurate’s patented spray system and other information REDACTED

REDACTED REDACTED

REDACTED

REDACTED

REDACTED

22. REDACTED

REDACTED

REDACTED

**C. 2019-2020: Akurate Discovers that Carlisle Fluid is Developing a Competing Spray Foam Applicator System.**

23. REDACTED Akurate

learned that Carlisle Fluid was developing a spray foam system for the Spray foam Polyurethane market.

<sup>3</sup> See MTA: Motion Tech Automation, “About Us: Meet the Team,” available at <https://www.motiontech.com/about-mta/meet-the-team/> (last accessed Aug. 12, 2020).

24. In February 2020, Akurate's Vice President Andy Hodgkinson attended the annual SPFA conference in Pasadena, CA, where Carlisle Fluid was advertising, marketing, and promoting equipment designed to work in the spray polyurethane and polyurea plastics markets, i.e. the Accused System. Carlisle Fluid's booth was manned by Mr. Donaldson (the Motion Tech engineer and the named inventor of the Carlisle patent application) and Fred Sutter, Motion Tech's President and CEO. The booth was generally open to SPFA attendants. Upon information and belief, Carlisle Fluid hired Motion Tech to develop Carlisle's spray foam system. When Mr. Hodgkinson attempted to view Carlisle's spray system, Carlisle Fluid refused to open the system and demonstrate the internal components. However, a third-party who is familiar with Akurate's system was permitted to enter Carlisle's booth and reviewed the internal components of the system. The third party confirmed to Akurate that Carlisle Fluid was marketing equipment that was functionally nearly identical to Akurate's. Akurate also learned from the third party that Carlisle's system used the same pump and flowmeter manufacturer that Akurate's system uses. Upon information and belief, Carlisle Fluid refused to show Mr. Hodgkinson the internal components of its Accused System because Carlisle Fluid knew that the Accused System deliberately included Akurate's Trade Secret/Confidential Information and infringed upon Akurate's '996 Patent.<sup>4</sup>

25.

REDACTED

[REDACTED]

26. Upon information and belief, Carlisle Fluid could not have developed its competing and functionally similar Accused System as quickly as it did but for Akurate's Trade

---

<sup>4</sup> Despite Akurate's repeated requests to Carlisle to supply information about the Accused System for Akurate's investigation of its claims in this litigation, to date, Carlisle has refused to do so.

Secret/Confidential Information **REDACTED**, and but for the use of Akurate's patented technology. Upon information and belief, Carlisle Fluid has been touting its manufacturing system and equipment design to win customers in this competitive field. Carlisle Fluid's spray polyurethane foam system, which uses a plurality of chemicals mixed only on application in real time, bears all the hallmarks of Akurate's system. Carlisle Fluid is creating spray foam processing equipment that functions nearly identically to Akurate's.

27. By unlawfully using Akurate's Trade Secret/Confidential Information **REDACTED**, and Akurate's patented technology, Carlisle Fluid was able to bypass three years of development Akurate invested in designing its system and now has the capacity to be a major player in spray foam insulation systems.

28. Upon information and belief, Carlisle Fluid is promoting, advertising, marketing, and offering for sale the Accused System in interstate commerce, a system it built by unlawfully using Akurate Trade Secret/Confidential Information, and Akurate's patented system and methods.

29. In January 2020, Trey Cook, Akurate's President, spoke to one of Carlisle Fluid's customers. Mr. Cook learned that a Carlisle Fluid representative was visiting Houston to market the Accused System to the customer. The Carlisle representative demonstrated the Accused System by spraying foam, touted that the Accused System was superior to other systems, and offered the Accused System for sale with Carlisle's fluids. The customer also informed Mr. Cook that the Carlisle representative's next stop was Austin, where the exact same demonstration was scheduled for another Carlisle Fluid customer. Upon information and belief, Carlisle Fluid demonstrated the Accused System and offered it for sale in Austin to Carlisle Fluid customers.

30. Unless this Court acts quickly to stop Carlisle Fluid's unlawful acts, Akurate will suffer irreparable harm as well as significant monetary damages.

**D. 2020: Akurate Notifies Carlisle Fluid of Its Suspected Misappropriation of Akurate's Trade Secrets and Confidential Information But Gets No Meaningful Response.**

31. On May 26, 2020, counsel for Akurate sent Carlisle Fluid's President, Shelley Bausch, a letter explaining it suspected Carlisle Fluid had REDACTED, misappropriated Akurate Trade Secret/Confidential Information, and infringed Akurate's patents in developing the Accused System, attached as **Exhibit C**. In an effort to resolve the matter without litigation, Akurate requested that Carlisle respond, by June 9, 2020, to its allegations and REDACTED

REDACTED *Id.* Rather than provide any information, On June 12, 2020, counsel for Carlisle Fluid contacted Akurate's counsel and requested that Akurate provide "claim charts...or any other basis for your allegations" that the Accused System infringed Akurate's patents. A true and correct copy of counsel for Carlisle Fluid's correspondence to counsel for Akurate, dated June 12, 2020, is attached hereto as **Exhibit D**. Carlisle's counsel did not show Akurate the Accused System or otherwise provide any bases to refute Akurate's allegations.

32. On July 3, 2020, Akurate notified Carlisle Fluid's counsel that it had filed its Complaint in this Court, and that Akurate did not intend to serve the Complaint until July 10 if "Akurate receives from Carlisle a prospective resolution or substantive response that alleviates Akurate's concerns about the allegations in the Complaint. A true and correct copy of counsel for Akurate's correspondence to counsel for Carlisle Fluid, dated July 3, 2020, is attached hereto as **Exhibit E**. On July 9 and July 13, Carlisle responded that Akurate's allegations were

meritless, but again did not provide any images or drawings of the Accused System to support that position. True and correct copies of counsel for Carlisle Fluid's correspondence, dated July 9 and July 13 respectively, are attached hereto as **Exhibit F**. Akurate served its Original Complaint on July 14, 2020.

**COUNT I—INFRINGEMENT OF THE '996 PATENT**

32. Akurate incorporates by reference the foregoing paragraphs of this Complaint as though the same were set forth at length herein.

33. Akurate owns the entire right, title, and interest in the '996 Patent, attached as **Exhibit A**.

34. The '996 Patent is valid and enforceable under the laws of the United States.

35. Akurate marks its spray foam system with the '996 Patent number.

36. On information and belief, in violation of 35 U.S.C. § 271(a), Carlisle Fluid directly infringed and continues to directly infringe (literally and/or by the doctrine of equivalents) at least claim 20 of the '996 Patent by using the Accused System to perform all of the method steps of claim 20. Akurate has not had access to the Accused System because Carlisle Fluid has repeatedly refused to provide it. However, upon information and belief, the Accused System is disclosed in Carlisle Fluid's U.S. Patent Pub. No. 2019/0022683 ("the '683 Patent Publication"). Attached as **Exhibit G** is a claim chart mapping the operation of system disclosed in Carlisle Fluid's '683 Patent Publication to claim 20 of the '996 Patent. Attached as **Exhibit H** is the '683 Patent Publication. Upon information and belief, Carlisle Fluid has directly infringed claim 20 by using the Accused System to spray foam insulation on surfaces, including in the Western District of Texas.

37. Carlisle Fluid's infringement of the '996 Patent has been and continues to be willful and deliberate. REDACTED

REDACTED When Carlisle Fluid got what it needed, REDACTED and then copied Akurate's system to compete against Akurate in the spray foam market. Carlisle Fluid has had knowledge of the '996 Patent at least since May 26, 2020, when counsel for Akurate sent Carlisle Fluid's President, Shelley Bausch, a notice of infringement. However, upon information and belief, Carlisle Fluid continues to use, sell, and/or offer for sale the Carlisle Fluid Accused System despite the known or obvious risk of infringement.

38. Akurate has been damaged and continues to be damaged by Carlisle Fluid's infringing acts.

**COUNT II—MISAPPROPRIATION OF TRADE SECRETS  
VIOLATION OF DTSA, 18 U.S.C. § 1836 et seq.**

39. Akurate incorporates by reference the foregoing paragraphs of this Complaint as though the same were set forth at length herein.

40. REDACTED

41. Akurate owns Akurate's Trade Secret/Confidential Information under 18 U.S.C. § 1839.

42. Akurate took reasonable measures to keep Akurate's Trade Secret/Confidential Information secret. For example, the trade secret methodology of Akurate's system is partially controlled by software that is embedded in Akurate's system and hidden from the system's operator. Additionally, Akurate did not disclose Akurate's Trade Secret/Confidential

Information to third parties without first securing a non-disclosure agreement, REDACTED

43. Akurate expended considerable time, effort, and expense to develop and protect Akurate's Trade Secret/Confidential Information. Akurate's Trade Secret/Confidential Information was not generally known to the public and was not readily ascertainable by proper means to persons who could derive value from their disclosure or use.

44. Akurate's Trade Secret/Confidential Information derived independent economic value, actual and/or potential, from not being generally known to, and not being readily ascertainable through proper means by, another person who could obtain economic value from their disclosure or that person's use. Akurate's Trade Secret/Confidential Information were of substantial economic value and have conferred a competitive advantage to Akurate over would-be competitors, including Carlisle Fluid. For example, to Akurate's knowledge, no other company has developed a dynamic, auto-adjusting system that achieves the precisely desired ratio of chemicals necessary to avoid shrinkage of spray foam and the release of odorous gasses. This advantage was and is being compromised as a result of Carlisle Fluid's unlawful activities.

45. REDACTED

46. Upon information and belief, Carlisle Fluid misappropriated Akurate's Trade Secret/Confidential Information when it developed a nearly functionally identical competing spray system, which, it could not have done but for Akurate's Trade Secret/Confidential Information.



47. As set forth above, Carlisle Fluid has wrongfully possessed, accessed, used, and/or disclosed Akurate's Trade Secret/Confidential Information without Akurate's express or implied consent. On information and belief, at the time of each such use and/or disclosure,

REDACTED

. To the extent some portion of Akurate's Trade Secret/Confidential Information ever became public information, that portion was misappropriated by Carlisle Fluid before the information became public. Carlisle Fluid has also misappropriated Akurate's Trade Secret/Confidential Information that is not public. As a result of its improper possession, use, and/or disclosure of Akurate's Trade Secret/Confidential Information, Carlisle Fluid has violated the Defend Trade Secrets Act.

48. As set forth above, Carlisle Fluid's conduct was willful and wanton. On information and belief, Carlisle Fluid used and misappropriated Akurate's trade secrets with blatant disregard for Akurate's valid and enforceable rights.

49. As a direct and proximate result of Carlisle Fluid's violation of the Defend Trade Secrets Act, Akurate has sustained damages in an amount to be determined at trial.

50. Unless enjoined by this Court, Carlisle Fluid's actions have caused and will continue to cause Akurate imminent and irreparable harm.

51. Akurate has no adequate remedy at law to redress the conduct complained of herein and will suffer continued imminent and irreparable harm as a result.

**COUNT III—MISAPPROPRIATION OF TRADE SECRETS  
VIOLATION OF TUTSA, TEX. CIV. PRAC. & REM. CODE ANN. § 134A.001 et seq.**

52. Akurate incorporates by reference the foregoing paragraphs of this Complaint as though the same were set forth at length herein.

53.

REDACTED

REDACTED Akurate owns Akurate's Trade Secret/Confidential Information under Tex. Civ. Prac. & Rem. Code § 134A.002(6).

54. Akurate's Trade Secret/Confidential Information are confidential and proprietary information, and Akurate has taken reasonable measures to keep that information secret, as detailed in paragraphs 42 and 43 above.

55. Akurate expended considerable time, effort, and expense to develop and protect Akurate's Trade Secret/Confidential Information. Akurate's Trade Secret/Confidential Information were not generally known to the public and not readily ascertainable by proper means to persons who could derive value from their disclosure or use.

56. Akurate's Trade Secret/Confidential Information derived independent economic value, actual and/or potential, from not being generally known to, and not being readily ascertainable through proper means by, another person who could obtain economic value from their disclosure or that person's use. Akurate's Trade Secret/Confidential Information were of substantial economic value and conferred a competitive advantage on Akurate over would-be competitors, including Carlisle Fluid. For example, to Akurate's knowledge, no other company has developed a dynamic, auto-adjusting system that achieves the precisely desired ratio of chemicals necessary to avoid shrinkage of spray foam and the release of odorous gasses. This advantage was and is being compromised as a result of Carlisle Fluid's unlawful activities.

57.

REDACTED

REDACTED

58. Upon information and belief, Carlisle Fluid misappropriated Akurate's Trade Secret/Confidential Information when it developed a nearly functionally identical competing spray system, which, it could not have done but for Akurate's Trade Secret/Confidential Information.

59. As set forth above, Carlisle Fluid has wrongfully possessed, accessed, used, and/or disclosed Akurate's Trade Secret/Confidential Information without any color of right and without Akurate's express or implied consent. On information and belief, at the time of each such use and/or disclosure, Carlisle Fluid knew or had reason to know that it acquired Akurate's Trade Secret/Confidential Information under circumstances giving rise to a duty to maintain their secrecy and limit their use. To the extent some portion of Akurate's Trade Secret/Confidential Information ever became public information, that portion was misappropriated by Carlisle Fluid before the information became public. Carlisle Fluid has also misappropriated Akurate's Trade Secret/Confidential Information that is not public. As a result of its improper possession, use, and/or disclosure of Akurate's trade secrets, Carlisle Fluid has violated the TUTSA.

60. As set forth above, Carlisle Fluid's conduct was willful and wanton. On information and belief, Carlisle Fluid used and misappropriated Akurate's trade secrets with blatant disregard for Akurate's valid and enforceable rights.

61. As a direct and proximate result of Carlisle Fluid's violation of the TUTSA, Akurate has sustained damages in an amount to be determined at trial.

62. Unless enjoined by this Court, Carlisle Fluid's actions have caused and will continue to cause Akurate imminent and irreparable harm.

63. Akurate has no adequate remedy at law to redress the conduct complained of herein and will suffer continued imminent and irreparable harm as a result.

**COUNT IV—BREACH OF CONTRACT**

64. Akurate incorporates by reference the foregoing paragraphs of this Complaint as though the same were set forth at length herein.

65. REDACTED

66. REDACTED

67. REDACTED

[REDACTED]

68. REDACTED

[REDACTED]

69. REDACTED

[REDACTED]

**COUNT V—UNJUST ENRICHMENT**

70. Akurate incorporates by reference the foregoing paragraphs of this Complaint as through the same were set forth at length herein.

71. As explained above, Carlisle Fluid misappropriated Akurate’s confidential information REDACTED.

72. Carlisle Fluid derived benefits, including commercial advantage and private financial gain, from its unauthorized use of Akurate’s confidential information.

73. Carlisle Fluid was on notice and/or fully aware that Akurate was the sole owner, creator, and source of Akurate's confidential information.

74. Carlisle Fluid obtained the benefit of using Akurate's confidential information without Akurate's notice, authorization, and/or permission.

75. Upon information and belief, Carlisle Fluid accepted and retained the benefit of accessing and using Akurate's confidential information to develop their own competing manufacturing process.

### **PRAYER FOR RELIEF**

WHEREFORE, Akurate demands judgment in its favor and against Carlisle Fluid:

- a. For a judgment finding that Carlisle Fluid directly infringes and has directly infringed the '996 Patent;
- b. For an Order finding that Carlisle Fluid has willfully infringed the '996 Patent;
- c. For damages to compensate Akurate for Carlisle Fluid's infringement of the '996 Patent pursuant to 35 U.S.C § 284, including enhanced damages up to three times the amount of damages found or measured and supplemental damages for any continuing post-verdict infringement up until entry of final judgment, with an accounting, as needed;
- d. An Order enjoining Carlisle Fluid, its officers, agents, employees, and those persons in active concert or participation with any of them, and Carlisle Fluid's successors and assigns, from continuing to infringe the '996 Patent; and
- e. For an Order that this case is exceptional pursuant to 35 U.S.C. § 285 and awarding Akurate its costs, expenses, and reasonable attorneys' fees incurred in this action;

- f. For actual damages that Akurate is entitled to recover as a result of Carlisle Fluid's misappropriation of Akurate's Trade Secret/Confidential Information, and enhanced damages due to Carlisle Fluid's willful and malicious conduct;
- g. For exemplary damages pursuant to 18 U.S.C. § 1836(b)(3)(c);
- h. For actual damages that Akurate is entitled to recover as a result of Carlisle Fluid's breach of the Carlisle NDA;
- i. For an Order requiring Carlisle Fluid to disgorge the profits earned as a result of its unjust enrichment;
- j. For an order awarding Akurate prejudgment and post-judgment interest;
- k. For an order awarding Akurate its costs;
- l. For an order awarding Akurate any other and further relief as the Court deems proper.

**DEMAND FOR JURY TRIAL**

Pursuant to Federal Rule of Civil Procedure 38, Akurate hereby demands a jury trial on issues so triable.

DATED: August 21, 2020

Respectfully submitted,

/s/ Domingo M. Llagostera  
Domingo M. Llagostera (State Bar No. 24070157)  
(Attorney-in-charge)  
Russell T. Wong (State Bar No. 21884235)  
**Blank Rome LLP**  
717 Texas Avenue, Suite 1400  
Houston, TX 77002  
Tel.: (713) 632-8682  
Fax: (713) 228-6605  
[dllagostera@BlankRome.com](mailto:dllagostera@BlankRome.com)  
[rwong@blankrome.com](mailto:rwong@blankrome.com)

**Attorneys for Plaintiff Akurate Dynamics, LLC**

**CERTIFICATE OF SERVICE**

I hereby certify that on August 21, 2020, the foregoing was electronically filed through the Court's CM/ECF system and thereby served on the following recipients:

**Barry K. Shelton**  
Shelton Coburn LLP  
311 Ranch Rd. 620 S., Suite 205  
Austin, TX 78734  
Tel: (512) 263-2165  
[bshelton@sheltoncoburn.com](mailto:bshelton@sheltoncoburn.com)

**Benjamin Behrendt**  
Kirkland and Ellis LLP  
1301 Pennsylvania Ave., NW  
Washington, DC 20004  
Tel: (202) 389-5145  
[benjamin.behrendt@kirkland.com](mailto:benjamin.behrendt@kirkland.com)

**Gregg LoCascio**  
Kirkland and Ellis LLP  
1301 Pennsylvania Ave., NW  
Washington, DC 20004  
Tel: (202) 389-5290  
[gregg.locascio@kirkland.com](mailto:gregg.locascio@kirkland.com)

**Nathan Mammen**  
Kirkland and Ellis LLP  
1301 Pennsylvania Ave., NW  
Washington, DC 20004  
Tel: (202) 389-5949  
[nathan.mammen@kirkland.com](mailto:nathan.mammen@kirkland.com)

*Attorneys for Defendant Carlisle Fluid Technologies, Inc.*

By: /s/ Domingo M. Llagostera  
Domingo M. Llagostera