

**IN THE UNITED STATES DISTRICT COURT  
FOR THE EASTERN DISTRICT OF TEXAS  
MARSHALL DIVISION**

**KARAMELION LLC,**

Plaintiff,

v.

**VERIZON COMMUNICATIONS, INC.,**

Defendant.

C.A. No. 2:20-cv-279

**JURY TRIAL DEMANDED**

**PATENT CASE**

**ORIGINAL COMPLAINT FOR PATENT INFRINGEMENT**

Plaintiff Karamelion LLC, files this Original Complaint for Patent Infringement against Verizon Communications, Inc., and would respectfully show the Court as follows:

**I. THE PARTIES**

1. Plaintiff Karamelion LLC (“Karamelion” or “Plaintiff”) is a Texas limited liability company with its principal place of business at 5570 FM 423, Suite 250 #2022, Frisco, TX 75034.

2. On information and belief, Defendant Verizon Communications, Inc. (“Defendant”) is a corporation organized and existing under the laws of Delaware, with a place of business at 500 E Loop 281, Longview, TX 75605. Defendant has a registered agent at CT Corporation System, 350 North St Paul Street, Dallas, TX 75201.

**II. JURISDICTION AND VENUE**

3. This action arises under the patent laws of the United States, Title 35 of the United States Code. This Court has subject matter jurisdiction of such action under 28 U.S.C. §§ 1331 and 1338(a).

4. On information and belief, Defendant is subject to this Court’s specific and general personal jurisdiction, pursuant to due process and the Texas Long-Arm Statute, due at

least to its business in this forum, including at least a portion of the infringements alleged herein. Furthermore, Defendant is subject to this Court's specific and general personal jurisdiction because it has a place of business at 500 E Loop 281, Longview, TX 75605, 2414 Gilmer Rd #1, Longview, TX 75604, 218 E, FM 544, Murphy, TX 75094, and 2330 Preston Rd Suite 500, Frisco, TX 75034.

5. Without limitation, on information and belief, within this state, Defendant has used the patented inventions thereby committing, and continuing to commit, acts of patent infringement alleged herein. In addition, on information and belief, Defendant has derived revenues from its infringing acts occurring within the Eastern District of Texas and Texas. Further, on information and belief, Defendant is subject to the Court's general jurisdiction, including from regularly doing or soliciting business, engaging in other persistent courses of conduct, and deriving substantial revenue from goods and services provided to persons or entities in Eastern District of Texas and Texas. Further, on information and belief, Defendant is subject to the Court's personal jurisdiction at least due to its sale of products and/or services within the Eastern District of Texas. Defendant has committed such purposeful acts and/or transactions in the Eastern District of Texas such that it reasonably should know and expect that it could be haled into this Court as a consequence of such activity.

6. Venue is proper in this district under 28 U.S.C. § 1400(b). Defendant has a place of business at 500 E Loop 281, Longview, TX 75605, 2414 Gilmer Rd #1, Longview, TX 75604, 218 E, FM 544, Murphy, TX 75094, and 2330 Preston Rd Suite 500, Frisco, TX 75034. On information and belief, from and within this District Defendant has also committed at least a portion of the infringements at issue in this case.

7. For these reasons, personal jurisdiction exists and venue is proper in this Court under 28 U.S.C. § 1400(b).

**III. COUNT I**  
**(PATENT INFRINGEMENT OF UNITED STATES PATENT NO. 6,275,166)**

8. Plaintiff incorporates the above paragraphs herein by reference.

9. On August 14, 2001, United States Patent No. 6,275,166 (“the ‘166 Patent”) was duly and legally issued by the United States Patent and Trademark Office. The application leading to the ‘166 patent was filed on January 19, 1999. (Ex. A at cover). The ‘166 Patent is titled “RF Remote Appliance Control/Monitoring System.” A true and correct copy of the ‘166 Patent is attached hereto as Exhibit A and incorporated herein by reference.

10. Plaintiff is the assignee of all right, title, and interest in the ‘166 patent, including all rights to enforce and prosecute actions for infringement and to collect damages for all relevant times against infringers of the ‘166 Patent. Accordingly, Plaintiff possesses the exclusive right and standing to prosecute the present action for infringement of the ‘166 Patent by Defendant.

11. The invention in the ‘166 Patent relates to control and monitoring of distributed systems in buildings such as systems for controlling and monitoring heating, air conditioning, lighting, security, occupancy, and usage of distributed facilities. (Ex. A at col. 1:5-12). Control of such distributed systems in the prior art commonly used computer networks and business software. (*Id.* at col. 1:11-13). A major difficult with such systems was the expense of wiring inter-connections between elements of the system, particularly when there are additions or changes to be made in the system. (*Id.* at col. 1:14-18). Prior art attempts to reduce the expense of the systems included using efficient network products such as using a widely known Ethernet

standard, using AC power wiring to transmit RF communications to remove controllers, and using a combination of wired and wireless communications. (*Id.* at col. 1:18-27).

12. However, these centralized wireless control systems for building appliances have not been widely used mainly because systems that have a sufficient communication ranges are normally subject to regulations and licensing requirements that are prohibitively expensive. (*Id.* at col. 1:28-32). Also, systems that are powerful enough to be used in widely distributed installations are unnecessarily expensive to be used in smaller installations. (*Id.* at col. 1:32-34). With respect to wireless communication, there is limited availability of RF carrier frequencies, and potential interference with other nearby systems that might be operating in similar frequencies. (*Id.* at col. 1:34-37). Because of the continued deficiencies of the prior art solutions, there was a need for a wireless appliance control system that overcomes the disadvantages of the prior art solutions. (*Id.* at col. 1:38-39).

13. The inventors developed an invention that “meets this need by providing a wireless configuration that uses a distributed array of low power (short range) wireless controllers that are also functional as relay units for communicating with a headend control computer at long range.” (*Id.* at col. 1:42-46).

14. The ‘166 patent discloses exemplary embodiments of the claimed invention. The claimed invention is typically implemented in a building or location that has an appliance control/monitoring system. (*Id.* at col. 3:64 – col. 4:7). For example, the following figure is of a building (11) having a distributed array of appliance management stations (12) that wirelessly communicate with a headend control station (14) (*Id.* at col. 3:66 – col. 4:4):

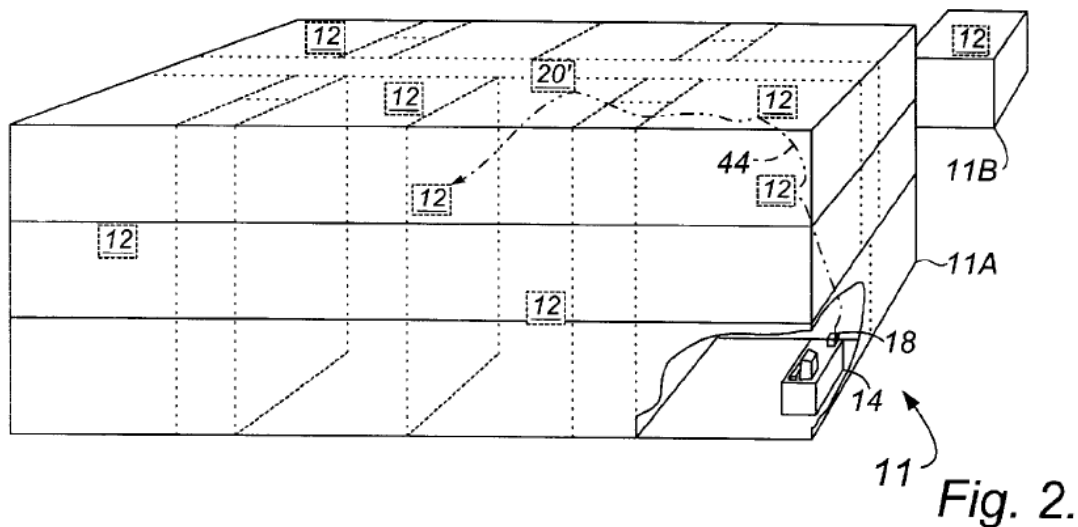

The typical appliances connected to the appliance control/monitoring system are heating, ventilation and air conditioning units (HVAC), temperature sensors, motion detectors, and audio/video devices. (*Id.* at col. 1:5-9, col. 4:54-61). The appliances are interfaced with relay units that have appliance interface/controllers to communicate with the appliance and satellite radio transceivers. (*Id.* at col. 4:62-66). The satellite radio transceivers of the relay units are operable at low power and have a limited wireless communications range that reaches only a portion of the building or location. (*Id.* at col. 4:62-66). In order to for the relay units to communicate beyond their limited wireless range, they communicate by relaying transmissions using intermediate relay units to the intended destination. (*Id.* at col. 4:66 – col. 5:1). An exemplary simplified circuit block diagram of the appliance controller portion of the relay unit, including a satellite radio transceiver, is shown in Figure 3 of the ‘166 patent:

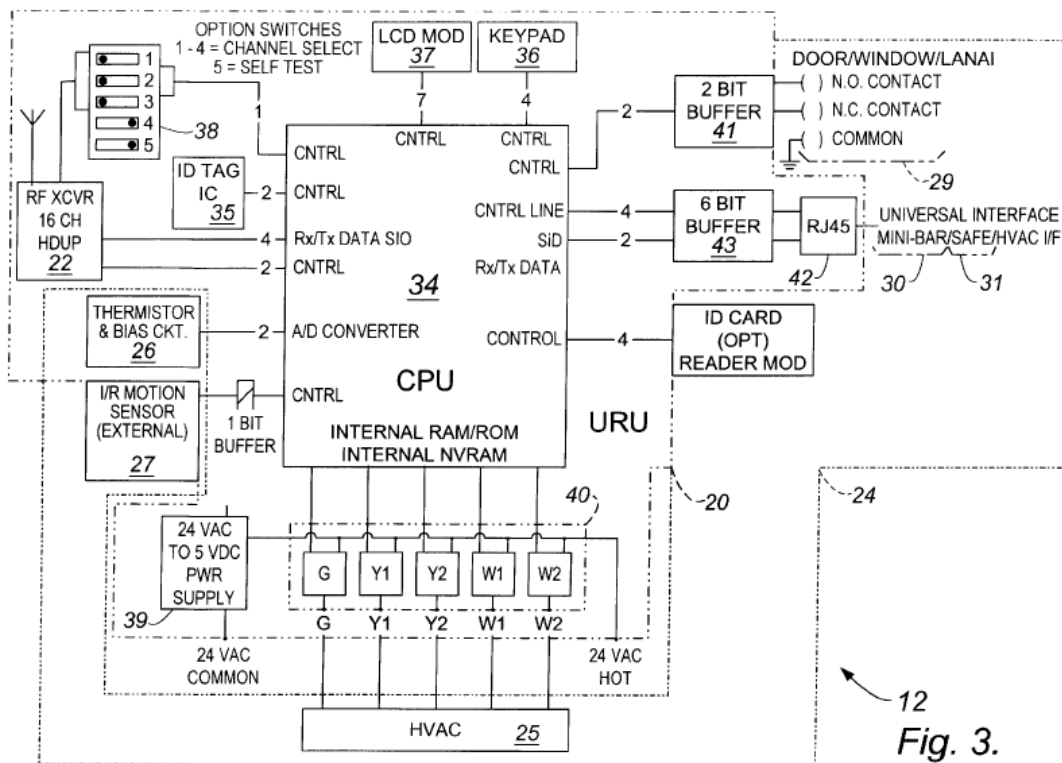

12  
Fig. 3.

(Ex. A). The microprocessor (34) is connected between a satellite transceiver (22) and the appliance device (24). (*Id.* at col. 5:13-15).

15. The '188 patent includes a diagram of an exemplary command protocol (Fig. 4) and exemplary return protocol (Fig. 5):

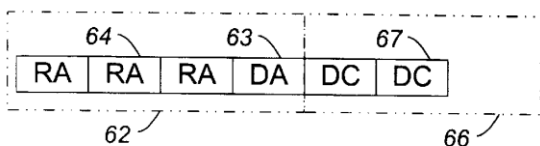

Fig. 4. 60

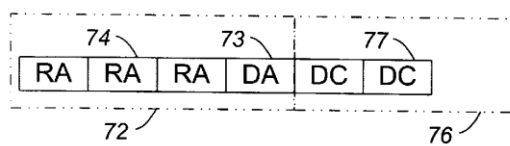

Fig. 5. 70

(Ex. A). The exemplary command protocol includes an address section (62) that includes a destination address (63) and may include relay addresses (64) so that the message may be relayed to another device. (*Id.* at col. 7:40-43). Following the address section is a command section (66) that includes device commands (67) that are directed to particular appliance devices at the destination relay unit. (*Id.* at col. 7:43-47). The exemplary return protocol includes a

counterpart of the address section (72) that includes a destination address (73) and relay addresses (74). (*Id.* at col. 7:48-51). Following the address section of the return protocol is a feedback section (76) that include feedback elements (77) that are responsive to the appliance devices at the destination relay unit. (*Id.* at col. 7:51-55).

16. A pictorial diagram showing an exemplary process for using a portion of the system is shown in Figure 6 of the '166 patent:

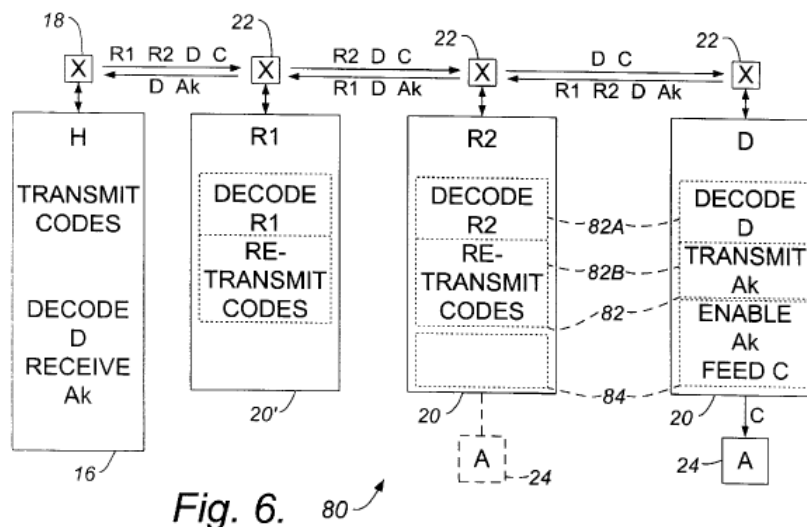

Fig. 6. 80

(Ex. A). A transmitter in the headend computer (H) signals the addresses of relay units (20), with one of the addresses being the destination address (D), and the other addresses include a first and second relay address (R1, R2), and a control signal (C) for appliance (A) being interfaced to the destination relay unit (D). (*Id.* at col. 7:56-65). The first relay unit decodes the first relay address, and transmits the control signal, the second relay address and the destination address from the first relay unit; the same steps occur at the second relay unit but with respect to decoding the second relay address. (*Id.* at col. 7:65 – col. 8:1). The destination relay unit decodes the destination address and feeds the control signal to the appliance; then the destination unit transmits the destination address, the first and second relay addresses, and an acknowledgement signal (Ak). (*Id.* at col. 8:2-6). The second relay unit decodes the second

relay address, and then transmits the acknowledgement signal (Ak), the first relay address, and the destination address; the same steps occur at the first relay unit but with respect to decoding the first relay address. (*Id.* at col. 8:6-9). The headend computer decodes the destination address and receives the acknowledgement signal (Ak). (*Id.* at col. 8:9-11). The decoding and transmitting in the relay units are implemented by first and second instruction portions (82A, 82B), respectively, of the relay program (82). (*Id.* at col. 8:11-14). The feeding of the control signal by the relay unit to the appliance and generating the acknowledgement signal occurs in the appliance program (84). (*Id.* at col. 8:14-16). Both the relay program and appliance program are in the microcomputer memory of each relay unit. (*Id.* at col. 8:16-18).

17. As explained during the prosecution history, the prior art did not teach a relay unit being an appliance controller that communicated with a headend computer using at least two other relay units. The invention therefore overcame the prior art, which were excessively expensive, had insufficient bandwidth, were ineffective in serving multiple devices, were unreliable, and were difficult to use. (Ex. B at col. 1:43-51).

18. **Direct Infringement.** Upon information and belief, Defendant has been directly infringed claim 16 of the '166 patent in Texas, and elsewhere in the United States, by performing actions comprising using an appliance controller for a distributed appliance system having a headend computer to satisfy the method steps of claim 16, including without limitation the Verizon SmartHub and Z-wave connected devices such as the Z-Wave Appliance Switch (“Accused Instrumentality”). (*e.g.*,

[http://web.archive.org/web/20180720091806mp\\_/https://www.verizonwireless.com/home-office-solutions/verizon-smarthub/](http://web.archive.org/web/20180720091806mp_/https://www.verizonwireless.com/home-office-solutions/verizon-smarthub/); <https://www.rvmobileinternet.com/verizon-introduces-smarthub-home-internet-replacement-with-a-huge-catch/>;



<https://www.youtube.com/watch?v=zdvAqNNWvAM;>

[http://web.archive.org/web/20140824002950/https://www.verizon.com/cs/groups/public/documents/onecmsresource/applianceswitch\\_ins\\_0dd6.pdf](http://web.archive.org/web/20140824002950/https://www.verizon.com/cs/groups/public/documents/onecmsresource/applianceswitch_ins_0dd6.pdf)).

19. On information and belief, Defendant performed the step of providing a headend computer having a main radio transceiver. For example, at least through testing and demonstrations, Defendant provides a primary controller such as the SmartHub.

20. On information and belief, Defendant performs the step of providing a distributed array of relay units, each relay unit having a satellite radio transceiver and a unique serial number, at least some of the relay units being electrically interfaced to a corresponding portion of the appliances. For example, Defendant provides a distributed array of relay units (*e.g.*, Z-Wave Appliance Switch acting as a repeater) each relay unit having a satellite radio transceiver (*e.g.*, a Z-Wave radio) and a unique serial number (*e.g.*, a NodeID), at least some of the relay units (*e.g.*, hardware within the appliance that allows for it to function as a repeater) being electrically interfaced to a corresponding portion of the appliances (*e.g.*, the hardware related to an appliance's repeater functionality is electrically connect to an appliance; *e.g.*, in the case of a Z-Wave Appliance Switch, the controller will have hardware allowing for it to serve as a repeater such as a Z-Wave radio, that is electronically connected to an appliance).

SmartHub can do more if you subscribe to Verizon Home, Verizon's new home automation platform. Home customers can unlock internet-connected deadbolts, adjust the brightness and color of smart bulbs, view and record security camera footage, and switch on and off your home's cooling system. And they can create routines using the SmartHub companion app – you could trigger a Nest thermostat when you're heading home from work, for example, or have a Kwikset lock unlock the front door when you pull into the driveway.



<https://www.digitaltrends.com/mobile/verizon-smarthub/>.<sup>1</sup>

---

<sup>1</sup> Red boxes and lines are added unless otherwise noted.

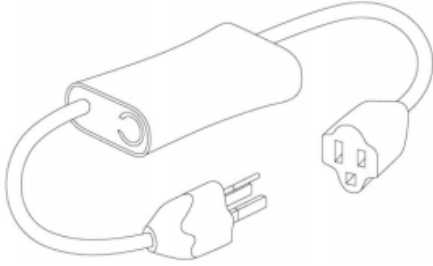

**INSTALLATION INSTRUCTIONS**

**Introduction:**

The Appliance Switch is a Z-Wave Appliance Switch which can report energy usage to a Z-Wave gateway. It can be remotely turned on/off to save electricity when appropriate.

The Appliance Switch is also a repeater in the Z-Wave network. It can act as a bridge for communication, forwarding Z-Wave instructions to their destinations if the gateway is out of range from the destination device.

With an unobtrusive small form factor, the Appliance Switch will not block other nearby AC outlets.

By taking advantage of the Z-Wave mesh network, commands can be routed to their destination via intermediary "listening" Z-Wave products. Products that are Z-Wave certified can be used to communicate with other Z-Wave certified devices.

[http://web.archive.org/web/20140824002950/https://www.verizon.com/cs/groups/public/documents/onecmsresource/applianceswitch\\_ins\\_0dd6.pdf](http://web.archive.org/web/20140824002950/https://www.verizon.com/cs/groups/public/documents/onecmsresource/applianceswitch_ins_0dd6.pdf)).

The Z-Wave Protocol handles transmissions to destinations all over the network. If necessary, other nodes are used as repeaters. This is called routing.

During bootstrapping, the Primary Controller asks the new node to discover its neighbors. Thanks to the neighbor nodes information, the Primary Controller builds a network map and knows the different possible routes to reach a node.

When using repeaters, the Sending node includes the route information in the frame. Each repeater parses the routing information and forwards the frame accordingly.

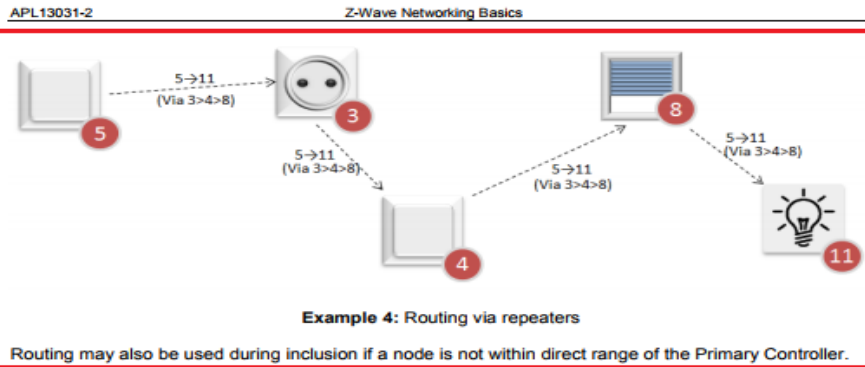

<http://zwavepublic.com/sites/default/files/APL13031-2%20-%20Z-Wave%20Networking%20Basics.pdf>



Z-Wave Alliance Recommendation ZAD12837-1

**Z-Wave Transceivers – Specification of Spectrum Related Components**

(2014)

**Scope**

This Recommendation provides guidelines pertaining to spectrum usage of the short range narrowband digital radiocommunication transceivers complying with ITU-T Recommendation G.9959. ITU-T Recommendation G.9959 contains the system architecture, physical layer (PHY) and medium access control layer (MAC) specifications for G.9959 compliant transceivers.

**References**

[1] Recommendation ITU-T G.9959, *Short range narrowband digital radiocommunication transceivers – PHY & MAC layer specifications*

**Definitions**

This Recommendation uses the following definitions:

**Channel:** a transmission path between nodes. One channel is considered to be one transmission path. Logically a channel is an instance of the communications medium used for the purpose of passing data between two or more nodes.

**Node:** any network device that contains a G.9959 transceiver. In the context of this Recommendation, use of the term ‘node’ without a qualifier means ‘G.9959 node’.

<https://z-wavealliance.org/wp-content/uploads/2015/02/ZAD12837-1.pdf>.

This command is used to set the network route to use when sending commands to the specified NodeID.

The use of this command is NOT RECOMMENDED.

7	6	5	4	3	2	1	0
COMMAND_CLASS = NETWORK_MANAGEMENT_INSTALLATION_MAINTENANCE							
COMMAND = PRIORITY_ROUTE_SET							
NodeID							
Repeater 1 [First repeater]							
Repeater 2							
Repeater 3							
Repeater 4 [Last repeater]							
Speed							

**NodeID (1 byte)**

This field is used to specify the destination NodeID for which a last working route MUST be set.

**Repeater (4 bytes)**

This field is used to specify repeaters for the route. Each byte represents a NodeID and the first field (Repeater 1) is the first repeater of the route.

The value 0x00 MUST indicate that the byte does not represent a repeater. If the route is shorter than four repeaters, unused repeaters fields MUST be set to 0x00. If Repeater 1 is set to 0x00, it means that the Last Working Route is direct (nodes are within direct reach).

([http://zwavepublic.com/sites/default/files/command\\_class\\_specs\\_2017A/SDS13784-4%20Z-Wave%20Network-Protocol%20Command%20Class%20Specification.pdf](http://zwavepublic.com/sites/default/files/command_class_specs_2017A/SDS13784-4%20Z-Wave%20Network-Protocol%20Command%20Class%20Specification.pdf)).

After Inclusion

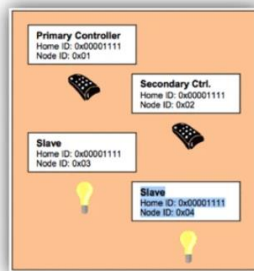

Figure 4 - Network after Inclusion

After successful Inclusion, all nodes have the same Home ID - they are connected to the same network. They also each have a unique Node ID, allowing them to be individually identified and communicate with each other.

In this example there are two controllers. The controller whose Home ID, became the Home ID for all devices, is called the 'primary controller.' All other controllers become 'secondary controllers.'

The primary controller can include further devices, whereas the secondary controller cannot. However, the primary and secondary controllers operate the same in all other respects.

(<https://www.vesternet.com/pages/understanding-z-wave-networks-nodes-devices>).

The Z-Wave routing layer controls the routing of frames from one node to another. Both controllers and slaves can participate in routing of frames in case they're always listening and have a static position. The layer is responsible for both sending a frame with a correct repeater list and ensuring that the frame is repeated from node to node. In the case of the controller device, the routing layer is also responsible for scanning the network topology and maintaining a routing table.

The Z-Wave application layer is responsible for decoding and executing commands in a Z-Wave network. The application layer frame contains a header that describes the type of frame, command information, and associated parameters. Commands are divided into two classes: Z-Wave protocol commands and application-specific commands. For most devices protocol-related commands cover only Home ID and Node ID assignment logic, but in more complex devices, such as the Static Update Controller (SUC) or SUC ID Server (SIS), additional network management functions are added.

Each Z-Wave network has a unique 32-bit identifier called *Home ID*. Controller devices have a preassigned network ID, slave devices obtain the Home ID from the controller upon joining the network. If another controller device joins the network, it inherits the Home ID from the primary controller.

Individual nodes in the network are addressed using an 8-bit *Node ID* that is assigned by the controller as well. The Node ID is unique only in the scope of its network.

To obtain node-specific information, Z-Wave uses a *node information frame*. This frame is part of the Z-Wave protocol and specifies the capabilities of the node. These capabilities are the node type, whether the node is able to repeat frames, and other protocol-relevant issues. The node information frame also contains the Home ID and the Node ID.

It is possible for the application to ask for the node information frame from all nodes in the network and hence enable any node to acquire information regarding any node's features in the network at any given time.

#### Device types

There are two main types of devices defined in Z-Wave protocol: controllers and slaves. *Controllers* are able to initiate transmission as well as hold all the smarts related to network routings. Slaves, on the other hand, are just end devices with general-purpose input output (GPIO)-type functionality that blindly execute the controller's requests. It's true for message retransmission as well: in the received packet the controller instructs a particular slave whether the message should be retransmitted or not.

Controllers are differentiated further depending on their functionality in the network. Major types are portable and static controllers.

(<https://www.embedded.com/catching-the-z-wave/>).

21. On information and belief, in at least internal testing and usage, Defendant performs the step of signaling, by a main transmitter from the headend computer (*e.g.*, the SmartHub serving as a controller) the addresses of at least three relay units, one of the addresses being a destination address, the other addresses including first and second relay addresses (*e.g.*, the address for two Z-Wave devices serving as repeaters and a destination Z-Wave device being controlled), and a control signal for an appliance being interfaced to a destination relay unit (*e.g.*, an appliance attached to the Z-Wave Appliance Switch) having a serial number tied to the destination address (*e.g.*, the destination device's NodeID will be tied to a destination address used in routing). (*Supra* ¶¶19-20).

[http://zwavepublic.com/sites/default/files/command\\_class\\_specs\\_2017A/SDS13782-4%20Z-Wave%20Management%20Command%20Class%20Specification.pdf](http://zwavepublic.com/sites/default/files/command_class_specs_2017A/SDS13782-4%20Z-Wave%20Management%20Command%20Class%20Specification.pdf);

<https://standards.ieee.org/getieee802/download/802.15.4-2011.pdf>;

<https://www.zwaveproducts.com/learn/ask-an-expert/glossary/mesh-network/>;

<http://docslide.us/documents/Z-Wave-technical-basics-small.html>;

<http://www.zwaveproducts.com/learn/Z-Wave>).

22. On information and belief, in at least internal testing and usage, Defendant performed the step of decoding the first relay address at a first relay unit having a corresponding serial number. For example, the Accused Instrumentality will decode a first relay address (*e.g.* the address for a first Z-Wave device used as a repeater) having a corresponding serial number (*e.g.* NodeID). (*Supra* ¶¶19-20).

Z-Wave enables a variety of monitoring and control applications. The basis for the applications is the networking services provided by the Z-Wave Protocol.

The Z-Wave Protocol can add and remove nodes in a network. This is known as inclusion and exclusion.

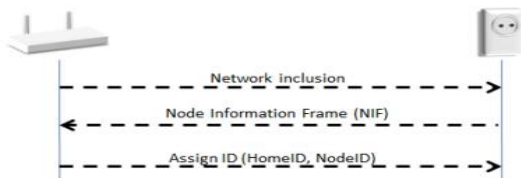

**Example 1:** Gateway adding a lamp to the network

A Z-Wave node is identified by its NodeID. All nodes in the network share the same HomeID. The NodeID and HomeID are assigned during inclusion. Inclusion is managed by a node known as the Primary Controller.

<http://zwavepublic.com/sites/default/files/APL13031-2%20-%20Z-Wave%20Networking%20Basics.pdf>

The Z-Wave Protocol handles transmissions to destinations all over the network. If necessary, other nodes are used as repeaters. This is called routing.

During bootstrapping, the Primary Controller asks the new node to discover its neighbors. Thanks to the neighbor nodes information, the Primary Controller builds a network map and knows the different possible routes to reach a node.

When using repeaters, the Sending node includes the route information in the frame. Each repeater parses the routing information and forwards the frame accordingly.

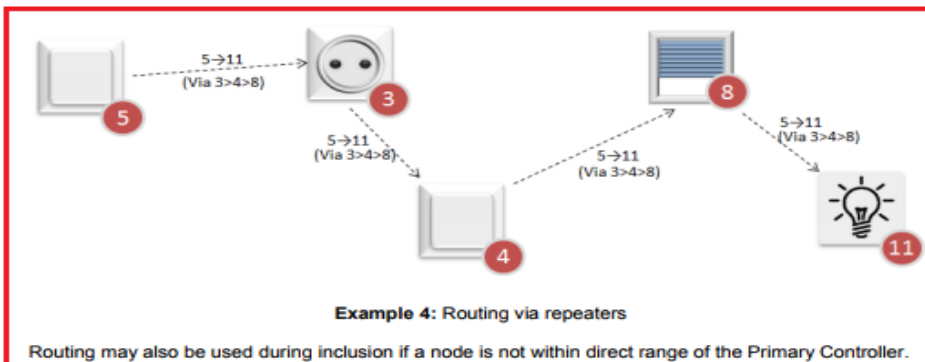

<http://zwavepublic.com/sites/default/files/APL13031-2%20-%20Z-Wave%20Networking%20Basics.pdf>



23. On information and belief, in at least internal testing and usage, Defendant performed the step of transmitting the control signal, the second relay address, and the destination address from the first relay unit. For example, the Accused Instrumentality will transmit the control signal (e.g. a signal to control a Z-Wave device), the second relay address (e.g. the first Z-Wave device serving as a repeater will inform the next repeater of the next device the message should be forwarded to) and the destination address (e.g. the first repeater will inform subsequent repeaters in the chain of the final destination device) from the first relay unit. (*Supra* ¶22).

24. On information and belief, in at least internal testing and usage, Defendant performed the step of feeding the control signal to the appliance from the destination relay unit. For example, the Accused Instrumentality feeds the control signal to the appliance from the destination relay unit (e.g. Z-Wave hardware within a Z-Wave device will feed the control signal to the hardware within the device that actually performs its core function, such as the connected appliance). (*Supra* ¶22).

25. On information and belief, in at least internal testing and usage, Defendant performed the steps of (a) transmitting the destination address, and an acknowledgement signal from the destination relay unit; (b) decoding the second relay address at the second relay unit; (c) transmitting the acknowledgement signal, the first relay address, and the destination address from the second relay unit; (d) decoding the destination address and receiving the acknowledgement signal at the headend computer. For example, Z-Wave devices will send an acknowledgement signal from a destination device back to a headend computer or controller. This is accomplished in a manner reverse of the procedure used to send a control signal from the

headend computer of controller to the destination device via intermediate devices serving as repeaters. (*Supra* ¶122).

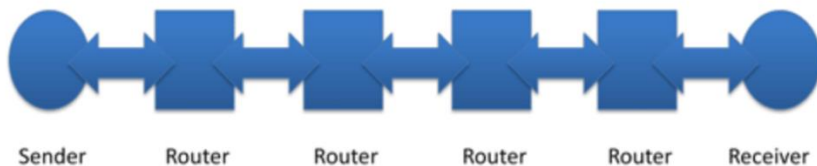

Figure 8 - Maximum distance between two nodes via four repeaters

(<https://www.vesternet.com/pages/understanding-z-wave-networks-nodes-devices>).

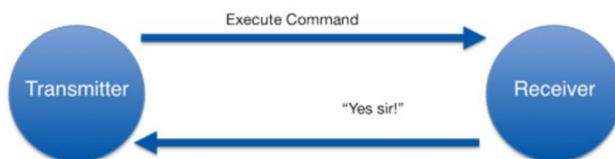

Figure 2 - communication with and without acknowledgment

The return receipt is called **Acknowledge (ACK)**. A Z-Wave transceiver will try up to three-times to send a message while waiting for an ACK. After three unsuccessful attempts the Z-Wave transceiver will give up and report a failure message to the user. The number of unsuccessful attempts is also a good indicator of the network's wireless connection quality.

(<https://www.vesternet.com/pages/understanding-z-wave-networks-nodes-devices>).

Z-Wave enables a variety of monitoring and control applications. The basis for the applications is the networking services provided by the Z-Wave Protocol.

The Z-Wave Protocol can add and remove nodes in a network. This is known as inclusion and exclusion.

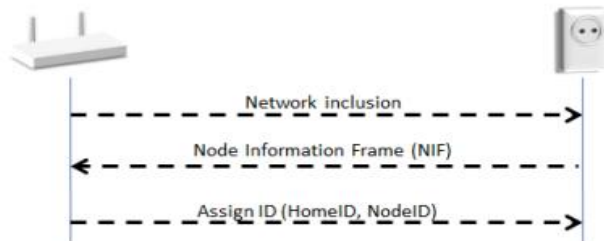

**Example 1:** Gateway adding a lamp to the network

A Z-Wave node is identified by its NodeID. All nodes in the network share the same HomeID. The NodeID and HomeID are assigned during inclusion. Inclusion is managed by a node known as the Primary Controller.

<http://zwavepublic.com/sites/default/files/APL13031-2%20-%20Z-Wave%20Networking%20Basics.pdf>).

**III. COUNT II**  
**(PATENT INFRINGEMENT OF UNITED STATES PATENT NO. 6,873,245)**

26. Plaintiff incorporates the above paragraphs herein by reference.

27. On March 29, 2005, United States Patent No. 6,873,245 (“the ‘245 Patent”) was duly and legally issued by the United States Patent and Trademark Office. The application leading to the ‘245 patent was filed on August 14, 2001, and is a continuation-in-part of the application leading to the ‘166 Patent. (Ex. B at cover). The ‘245 Patent is titled “RF Remote Appliance Control/Monitoring System.” A true and correct copy of the ‘245 Patent is attached hereto as Exhibit B and incorporated herein by reference.

28. Plaintiff is the assignee of all right, title and interest in the ‘245 patent, including all rights to enforce and prosecute actions for infringement and to collect damages for all relevant times against infringers of the ‘245 Patent. Accordingly, Plaintiff possesses the exclusive right and standing to prosecute the present action for infringement of the ‘245 Patent by Defendant.

29. Because the ‘245 patent is a continuation in part of the application leading to the ‘166 patent, the ‘245 patent has a substantially overlapping specification and the background regarding the ‘166 patent is equally applicable and is incorporated by reference with respect to the ‘245 patent. (*Supra* ¶¶11-17).

30. **Direct Infringement.** Upon information and belief, Defendant has been directly infringing at least claim 1 of the ‘245 patent in Texas, and elsewhere in the United States, by performing actions comprising making, using, selling, and/or offering for sale an appliance controller for a distributed appliance systems having a multiplicity of appliances, and a plurality

of relay units, that satisfies the limitations of at least claim 1, including without limitation the Verizon SmartHub and Z-wave connected devices such as the Z-Wave Appliance Switch (“Accused Instrumentality”).

31. Each Accused Instrumentality provides an appliance controller (*e.g.*, Z-Wave Appliance Switch) for a distributed appliance system (*e.g.*, Z-Wave network) having a multiplicity of appliances (*e.g.*, appliances such as lights/fans, etc.), and a plurality of relay units (*e.g.*, repeaters), one of the relay units being the appliance controller (*e.g.*, a SmartHub). (*Supra* ¶20; [http://zwavepublic.com/sites/default/files/command\\_class\\_specs\\_2017A/SDS13782-4%20Z-Wave%20Management%20Command%20Class%20Specification.pdf](http://zwavepublic.com/sites/default/files/command_class_specs_2017A/SDS13782-4%20Z-Wave%20Management%20Command%20Class%20Specification.pdf); <http://zwavepublic.com/sites/default/files/APL13031-2%20-%20Z-Wave%20Networking%20Basics.pdf>)

32. Each Accused Instrumentality has a low power satellite radio transceiver (*e.g.*, radio frequency transceivers within the various Z-Wave devices) having a range being less than a distance to at least some of the appliances. (*Supra* ¶20).

33. Each Accused Instrumentality has an appliance interface for communicating with the at least one local appliance (*e.g.*, an interface which connects and makes possible the transmission of signal to the actual electrical appliance like a light or fan). (*Supra* ¶20).

34. Each Accused Instrumentality has a microcomputer (*e.g.*, microcontroller) connected between the satellite radio transceiver (*e.g.*, Z-Wave transceiver) and the appliance interface and having first program instructions for controlling the satellite transceiver (*e.g.*, the microcontroller controls the transmission of signals from the transceiver to the other Z-Wave nodes in the network) and second program instructions for directing communication between the satellite transceiver and the appliance interface (*e.g.*, the microcontroller within the Z-Wave

device enables the command received from the appliance interface to be communicated to the local appliance by the Z-Wave transceiver so that the intended action can be executed such as control lights or fans). (*Supra* ¶¶20, 22; <https://Z-Wavealliance.org/Z-Wave-oems-developers/>; [http://zwavepublic.com/sites/default/files/command\\_class\\_specs\\_2017A/SDS13782-4%20Z-Wave%20Management%20Command%20Class%20Specification.pdf](http://zwavepublic.com/sites/default/files/command_class_specs_2017A/SDS13782-4%20Z-Wave%20Management%20Command%20Class%20Specification.pdf); <http://www.rfwireless-world.com/Tutorials/Z-Wave-physical-layer.html>).

35. Each Accused Instrumentality has a first program instructions including detecting communications directed by another of the relay units (*e.g.*, another Z-Wave node acting as a repeater) relative to the same appliance controller (*e.g.*, targeted Z-Wave node), signaling receipt of the directed communications (sending acknowledgement signal through the Z-Wave transceiver), and directing communications to the other of the relay units relative to the same appliance controller (*e.g.*, sending status of an appliance or signal from a connected sensor). For example, a Z-Wave controller can send/receive messages to program various connected Z-Wave devices; the Z-Wave Appliance Switch can receive communications to turn on or off appliances or can communicate regarding the status of the appliance. (*Supra* ¶20; <http://zwavepublic.com/sites/default/files/APL13031-2%20-%20Z-Wave%20Networking%20Basics.pdf>; [http://zwavepublic.com/sites/default/files/command\\_class\\_specs\\_2017A/SDS13784-4%20Z-Wave%20Network-Protocol%20Command%20Class%20Specification.pdf](http://zwavepublic.com/sites/default/files/command_class_specs_2017A/SDS13784-4%20Z-Wave%20Network-Protocol%20Command%20Class%20Specification.pdf)).

36. Each Accused Instrumentality has a second program instructions including detecting relay communications directed between the another of the relay units and a different relay unit, transmitting the relay communications, detecting a reply communication from the different relay unit, and transmitting the reply communication to the other of the relay units,

wherein at least some of the relay units communicate with others of the relay units by relay communications using at least two others of the relay units (*e.g.*, a Z-Wave node detects messages from primary controller and checks whether message is intended for itself, if not, then acting as a repeater, transmits it to next intended device in the route. Also, the Z-Wave node detects messages from another Z-Wave node and forwards it to primary controller. N number of nodes may be involved in the process acting as repeaters or relay units). The Accused Instrumentality works on Z-Wave technology which uses mesh network and would communicate with the other relay units by relay communications using at least two others of the relay units (*e.g.*, repeaters). (*Supra* ¶¶20, 24; <http://zwavepublic.com/sites/default/files/APL13031-2%20-%20Z-Wave%20Networking%20Basics.pdf>; [http://zwavepublic.com/sites/default/files/command\\_class\\_specs\\_2017A/SDS13784-4%20Z-Wave%20Network-Protocol%20Command%20Class%20Specification.pdf](http://zwavepublic.com/sites/default/files/command_class_specs_2017A/SDS13784-4%20Z-Wave%20Network-Protocol%20Command%20Class%20Specification.pdf); <https://www.zwaveproducts.com/learn/ask-an-expert/glossary/mesh-network/>; <http://docslide.us/documents/Z-Wave-technical-basics-small.html>; <http://www.zwaveproducts.com/learn/Z-Wave>).

37. Plaintiff has been damaged because of Defendant's infringing conduct. Defendant is thus liable to Plaintiff for damages in an amount that adequately compensates Plaintiff for such Defendant's infringement of the '166 Patent and the '245 Patent, *i.e.*, in an amount that by law cannot be less than would constitute a reasonable royalty for the use of the patented technology, together with interest and costs as fixed by this Court under 35 U.S.C. § 284.

38. On information and belief, Defendant had at least constructive notice of the '166 Patent and the '245 Patent by operation of law, and there are no marking requirements that have not been complied with.

#### **IV. JURY DEMAND**

Plaintiff, under Rule 38 of the Federal Rules of Civil Procedure, requests a trial by jury of any issues so triable by right.

#### **V. PRAYER FOR RELIEF**

WHEREFORE, Plaintiff respectfully requests that the Court find in its favor and against Defendant, and that the Court grant Plaintiff the following relief:

- a. Judgment that one or more claims of United States Patent No. 6,275,166 have been infringed, either literally and/or under the doctrine of equivalents, by Defendant;
- b. Judgment that one or more claims of United States Patent No. 6,873,245 have been infringed, either literally and/or under the doctrine of equivalents, by Defendant;
- c. Judgment that Defendant account for and pay to Plaintiff all damages to and costs incurred by Plaintiff because of Defendant's infringing activities and other conduct complained of herein, and an accounting of all infringements and damages not presented at trial;
- d. That Plaintiff be granted pre-judgment and post-judgment interest on the damages caused by Defendant's infringing activities and other conduct complained of herein;
- e. That Plaintiff be granted such other and further relief as the Court may deem just and proper under the circumstances.

August 27, 2020

Respectfully Submitted,

/s/ David R. Bennett

David R. Bennett

Direction IP Law

P.O. Box 14184

Chicago, IL 60614-0184

(312) 291-1667

dbennett@directionip.com

**ATTORNEYS FOR PLAINTIFF  
KARAMELION LLC**