

**IN THE UNITED STATES DISTRICT COURT
FOR THE DISTRICT OF DELAWARE**

| | | |
|---------------------------------|---|--------------------------|
| VOLTERRA SEMICONDUCTOR LLC, |) | |
| |) | |
| Plaintiffs, |) | |
| |) | |
| v. |) | C.A. No. 19-cv-02240-CFC |
| |) | |
| MONOLITHIC POWER SYSTEMS, INC., |) | [REDACTED] |
| |) | |
| Defendant. |) | |

SECOND AMENDED COMPLAINT FOR PATENT INFRINGEMENT

Pursuant to the Court’s Order at the September 10, 2020 Scheduling Conference, Plaintiff Volterra Semiconductor LLC (“Volterra” or “Plaintiff”) files this Second Amended Complaint for patent infringement against Defendant Monolithic Power Systems, Inc. (“Monolithic” or “Defendant”) and alleges as follows:

NATURE OF THE ACTION

1. This is a civil action for patent infringement under the patent laws of the United States, 35 U.S.C. § 1, *et seq.*
2. Defendant has infringed and continues to infringe, has contributed to and continues to contribute to the infringement of, and has induced and continues to induce the infringement of one or more claims of U.S. Patent Nos. 6,362,986 (“the ’986 patent”); 7,525,408 (“the ’408 patent”); and 7,772,955 (“the ’955 patent”) (collectively, the “Asserted Patents”) at least by making, using, selling, offering for sale, and importing into the United States DC-to-DC power converters that infringe one or more claims of each of the Asserted Patents.
3. Volterra is the legal owner by assignment of the Asserted Patents, which were duly and legally issued by the United States Patent and Trademark Office (“USPTO”). Volterra seeks



monetary damages and injunctive relief to address ongoing infringement of its valuable patent portfolio.

THE PARTIES

4. Plaintiff Volterra Semiconductor LLC (“Volterra”) is a corporation organized and existing under the laws of the State of Delaware and having its principal place of business at 160 Rio Robles, San Jose, California, 95134. Volterra Semiconductor LLC is the successor to Volterra Semiconductor Corporation, a corporation previously existing and incorporated under the laws of the State of Delaware. In October, 2013, Volterra Semiconductor Corporation was acquired by Maxim Integrated Products, Inc. (“Maxim Integrated Products”). On June 27, 2014, Volterra Semiconductor Corporation was converted to a limited liability corporation, Volterra Semiconductor, LLC, pursuant to Section 18-214 of the Delaware Limited Liability Corporation Act. 6 Del. C. § 18-214. Volterra Semiconductor LLC remains a wholly owned subsidiary of Maxim Integrated Products. Maxim Integrated Products, Inc. is a corporation organized under the laws of the State of Delaware.

5. Upon information and belief, Defendant Monolithic Power Systems, Inc. is a Delaware corporation with its principal place of business at 79 Great Oaks Blvd, San Jose, California 95119.

6. Monolithic, either itself and/or through the activities of its subsidiaries, makes, uses, sells, offers for sale, and/or imports throughout the United States, including within this District, products, such as DC-to-DC power converters, that infringe the Asserted Patents.

JURISDICTION AND VENUE

7. This is a civil action for patent infringement arising under the patent laws of the United States, 35 U.S.C. §§ 1 *et seq.*



8. This Court has subject matter jurisdiction over the matters asserted herein under 28 U.S.C. §§ 1331 and 1338(a).

9. Monolithic is subject to this Court's personal jurisdiction. Monolithic is incorporated in this District.

10. The Court therefore has both general and specific personal jurisdiction over Monolithic.

11. Venue is proper in this District pursuant to 28 U.S.C. § 1400(b) at least because, as discussed above, Monolithic is incorporated in this District and hence resides in this District.

FACTUAL BACKGROUND

12. In October, 2013, Volterra Semiconductor Corporation was acquired by Maxim Integrated Products, and subsequently re-organized as Volterra Semiconductor LLC, a wholly owned subsidiary of Maxim Integrated Products.

13. Volterra designed, developed, and marketed leading edge silicon solutions for low-voltage power delivery. The company's product portfolio included advanced switching regulators for the computer, datacom, storage, and portable markets. Volterra focused on creating products with high intellectual property content that match specific customer needs. The company has been an industry leader in high-current, high-performance, and high-density power management solutions and has developed highly integrated solutions primarily for the enterprise, cloud computing, communications, and networking markets. Volterra's portfolio of highly integrated products enables better performance, smaller form factors, enhanced scalability, improved system management, and lower total cost of ownership.

THE ASSERTED PATENTS

14. The '986 patent, issued on March 22, 2001, is entitled "Voltage converter with coupled inductive windings, and associated methods." Aaron M. Schultz and Charles R. Sullivan



are the named inventors. Volterra is the original and current owner by assignment of the '986 patent. A true and correct copy of the '986 patent is attached hereto as Exhibit A.

15. The '408 patent, issued on April 28, 2009, is entitled "Method for making magnetic components with N-phase coupling, and related inductor structures." Jieli Li, Charles R. Sullivan, and Angel Gentchev are the named inventors. Volterra is the original and current owner by assignment of the '408 patent. A true and correct copy of the '408 patent is attached hereto as Exhibit B.

16. The '955 patent, issued on August 10, 2010, is entitled "Method for making magnetic components with N-phase coupling, and related inductor structures." Jieli Li, Charles R. Sullivan, and Angel Gentchev are the named inventors. Volterra is the original and current owner by assignment of the '955 patent. A true and correct copy of the '955 patent is attached hereto as Exhibit C.

ACTS GIVING RISE TO THIS ACTION

17. The allegations provided below are exemplary and without prejudice to Volterra's infringement contentions. In providing these allegations, Volterra does not convey or imply any particular claim constructions or the precise scope of the claims. Volterra's claim construction contentions regarding the meaning and scope of the claim terms will be provided under the Court's scheduling order and local rules.

18. The Accused Products are the 48V-1V Power Solution for CPU, SoC or ASIC Controller that Monolithic demonstrated at the 2019 IEEE Applied Power Electronics Conference and Exposition ("APEC 2019") in Anaheim, CA, as well as any other substantially similar products.

19. As detailed below, each element of at least one claim of each of the Asserted Patents is literally present in the Accused Products, or is literally practiced by the Accused Products. To



the extent that any element is not literally present or practiced, each such element is present or practiced under the doctrine of equivalents.



20. Monolithic has made extensive use of Volterra's patented technologies, including the technology described and claimed in the Asserted Patents. Volterra has no choice but to defend its proprietary and patented technology. Volterra thus requests that this Court award it damages sufficient to compensate for Monolithic's infringement of the Asserted Patents, find this case exceptional and award Volterra its attorneys' fees and costs, and grant an injunction against Monolithic to prevent ongoing infringement of the Asserted Patents.

COUNT I: INFRINGEMENT OF U.S. PATENT NO. 6,362,986

21. Volterra incorporates by reference and realleges all the foregoing paragraphs of this Complaint as if fully set forth herein.

22. On information and belief, Monolithic has directly infringed, continues to infringe, and/or has induced or contributed to the infringement of at least claims 17–18, 20–21, and 23 of the '986 patent by making, using, selling, offering for sale, and/or importing into the United States, without authority or license, the Accused Products in violation of 35 U.S.C. § 271(a). For example, Monolithic directly infringed the '986 patent when it demonstrated its 48V-1V Power Solution for CPU, SoC or ASIC Controller at APEC 2019.

23. Monolithic has had knowledge of the '986 patent and that its activities infringe the '986 patent long before the filing of this action. Specifically, the follow activities demonstrate Monolithic's *presuit* knowledge and intent regarding the '986 patent:

- a. In approximately June 2019, Monolithic engaged in communications with potential customer, . In these discussions, Monolithic specifically discussed the Volterra patent portfolio related to coupled inductor based voltage converters. Monolithic expressed to  that it did not feel that the Volterra

[REDACTED]

patents would be a problem for at least the reason that the patents would be expiring soon. The '986 patent is the first patent to expire in the Volterra patent portfolio related to coupled inductor based voltage converters. As such, the reference by Monolithic to expiring Volterra patents evidences Monolithic's knowledge and intent regarding at least the '986 patent.

- b. In the third quarter of 2019, prior to the filing of the Complaint, Monolithic contacted component manufacturer [REDACTED] and requested that [REDACTED] develop a coupled inductor for Monolithic's use. In response to Monolithic's request, [REDACTED] asked Monolithic about Volterra's coupled inductor patents and asked if Monolithic could satisfy [REDACTED] that there would not be infringement of Volterra patents related to voltage converters based on a coupled inductor architecture. On information and belief, Monolithic did not respond to [REDACTED] request or otherwise satisfy [REDACTED] inquiry.
- c. During the course of Monolithic's work with potential customer [REDACTED] in 2018, an [REDACTED] engineer raised Volterra's coupled inductor patents with Monolithic.
- d. Technical publications by Monolithic engineers, including at least one who has submitted a declaration in this case regarding the products at issue, show that Monolithic specifically was familiar with Volterra's coupled inductor patents, including the '986 patent. This is not surprising since Volterra's coupled inductor patents are widely known in this industry. Multiple Monolithic senior engineers have written technical papers in which they discussed the '986 patent and the Volterra patented designs at length.

- [REDACTED]
- i. Jinghai Zhou is a senior engineer for Monolithic with extensive knowledge of the '986 patent and Volterra's patented designs since 2005. According to Mr. Zhou's LinkedIn profile (<https://www.linkedin.com/in/jinghai-zhou-4b9b5b30/>), he has been continuously employed by Monolithic since February 2006 and held the title of Director of Applications until January 2019 when he became a Senior Director. Mr. Zhou submitted a declaration in this case and claimed to "communicate regularly with customers about MPS products and opportunities to work together on products." (D.I. 43 at ¶ 1). Mr. Zhou's declaration also illustrates his familiarity with the controllers and coupled inductors at issue in this case. Mr. Zhou also has extensive familiarity with the '986 patent as illustrated in his dissertation. In Mr. Zhou's April 22, 2005 Dissertation, entitled "High Frequency, High Current Density Voltage Regulators," he analyzed what he called the "scalable multi-phase surface mount coupling inductor structure *proposed by Volterra.*" To illustrate what he meant by the structure proposed by Volterra, Mr. Zhou *cited the '986 patent* as well as multiple related papers by the inventors of the '986 patent. An excerpt from the dissertation along with the citations is shown below:

Based on this understanding, a scalable multi-phase surface mount coupling inductor structure is proposed by [77, 78], as shown in Figure 4.15. For each phase, there is one copper winding around the H-core so that the leg for leakage flux path (center leg in Figure 4.1) is eliminated.

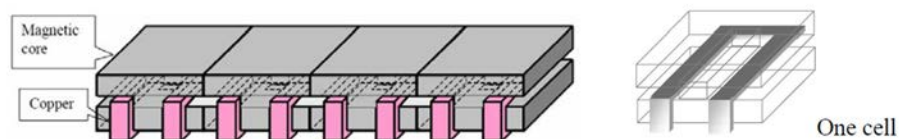

Figure 4.15 A scalable multi-phase surface mount coupling inductor structure proposed by Volterra in [77]



- [76] Jieli Li; Sullivan, C.R.; Schultz, A., "Coupled-inductor design optimization for fast-response low-voltage DC-DC converters," APEC 2002. Seventeenth Annual IEEE, Volume: 2, 10-14 March 2002, Pages: 817 – 823.
- [77] Jieli Li, Schultz, A., Stratakos, A., Sullivan, C.R., "Using Coupled Inductors to Enhance Transient Performance of Multi-Phase Buck Converters," APEC 2004. Seventeenth Annual IEEE, Volume: 2, 10-14 March 2002, Pages: 817 – 823.
- [78] Aaron M. Schultz, Charles R. Sullivan, "Voltage Converter with Coupled Inductive Windings, and Associated Methods," U. S. Patent 6362986 B1, March 26, 2002.

ii. Yan Dong was another Monolithic engineer with long-standing extensive knowledge of the '986 patent and the patented Volterra designs, further confirming the widely known nature of the Volterra patents at Monolithic and throughout the industry. According to Mr. Dong's LinkedIn profile, he began working at Monolithic in November 2008 and held the title of Power Architect/Senior Design Engineer until September 2016. (<https://www.linkedin.com/in/yan-dong-56583639/>). In Mr. Dong's Dissertation, entitled "Investigation of Multiphase Coupled-Inductor Buck Converters in Point-of-Load Applications," he discussed Volterra's inventions and cited papers written by the inventors of the '986 patent.

- [40] J. Li, A. Stratakos, A. Schultz, C. R. Sullivan, "Using coupled-inductors to enhance transient performance of multi-phase buck converters," in Proc. IEEE APEC '04, Feb. 22-26, 2004, Anaheim, CA, pp. 1289–1293.
- [41] Jieli Li, Charles R. Sullivan, Aaron Schultz, "Coupled-inductor design optimization for fast-response low-voltage DC-DC converters", in Proceedings of APEC 2002 - Applied Power Electronics Conf., pp. 817–823 vol.2.
- [42] A. M. Schultz and C. R. Sullivan, "Voltage converter with coupled inductive windings and associated methods", U.S. Patent 6,362,986, Mar. 26, 2002, Volterra Semiconductor Corp.

e. Finally, Volterra realleges that Monolithic's knowledge and intent is further demonstrated by post-suit activity. By at least December 9, 2019, Volterra disclosed, at least by filing its Complaint, the existence of the '986 patent and identified at least some of Monolithic's and others' activities that infringe the '986



patent. Thus, based on this disclosure, Monolithic had knowledge of the '986 patent and that its activities infringe the '986 patent since at least December 9, 2019. Based on Volterra's disclosures, Monolithic has also known or should have known since at least December 9, 2019 that its customers, distributors, suppliers, and other purchasers of the Accused Products are infringing the '986 patent at least because Monolithic has known that it is infringing the '986 patent.

24. Monolithic also actively, knowingly, and intentionally induces infringement of one or more claims of the '986 patent under 35 U.S.C. § 271(b) by actively encouraging others to import into the United States, and/or make, use, sell, and/or offer to sell in the United States, the Accused Products or products containing the infringing components of the Accused Products.

- a. For example, Monolithic actively promotes the sale, use, and importation of the Accused Products in marketing materials and videos made available on its YouTube channel (e.g., www.youtube.com/channel/UCqOx8jWRKEq4TpfcjCz0Isw) as well as at trade shows (e.g., APEC 2019) and through its sales and distribution channels that encourage infringing uses, sales, offers to sell, and importation of the Accused Products.
- b. As another example, Monolithic designs controllers that operate in a Couple Inductor mode, including the MP2888A controller and the MP2965 controller. The MP2888A controller includes a "digital PWM-VID interface compatible with NVIDIA's Open VReg specification" and "supports couple-inductor mode to reduce the overshoot during load releasing." (<https://www.monolithicpower.com/jp/documentview/productdocument/index/ver>



sion/2/document_type/Datasheet/lang/EN/sku/MP2888A). Revision 1.1 of the MP2888A datasheet is dated December 25, 2018, prior to the filing of the Complaint. (*Id.*). The MP2965 is “Intel VR13.HC/IMVP9 Compliant” and “supports couple inductor mode to reduce the overshoot during load releasing.” (https://www.monolithicpower.com/jp/documentview/productdocument/index/version/2/document_type/Datasheet/lang/EN/sku/MP2965). Monolithic makes the datasheets for each of these controllers publicly available, and these datasheets describe Couple Inductor mode and instruct customers how to program the controllers to operate in Couple Inductor mode.

| Bits | Bit Name | Description |
|-------|---------------|---|
| 15:10 | RESERVED | Unused. X indicates that writes are ignored and reads are always 0. |
| 9 | OCW_PWRALT_EN | Enable bit to assert PWR_IN_ALT# when the sensed output current is higher than IOUT_OC_WARN_LIMIT. IOUT_OC_WARN_LIMIT is set with the PMBus command IOUT_OC_WARN_LIMIT (4Ah). 1'b0: does not assert PWR_IN_ALT# when IOUT exceeds the OC warning limit 1'b1: assert PWR_IN_ALERT# when IOUT exceeds the OC warning limit |
| 8 | PH1_CPL_EN | Enable couple inductor mode in 1-phase operation. This bit is for Rail 1 only. When enabled, at 1-phase mode, PWM4 also pulls low when PWM1 is high, so the low-side MOSFET of Phase 4 is on to conduct the Phase 4 coupled current. 1'b0: disable couple inductor mode for 1-phase operation 1'b1: enable couple inductor mode for 1-phase operation |
| 7 | CPL_MODE_EN | Enables Rail 1 couple inductor mode. 1'b0: disable couple inductor mode 1'b1: enable couple inductor mode |

| Bits | Bit Name | Description |
|------|----------------------|--|
| 7:6 | RESERVED | Unused. X indicates that writes are ignored and always read as 0. |
| 5 | COUPLE_INDUCTOR_PWM6 | PWM6 performance selector to fit coupled inductor operating mode. 0: PWM6 remains in tri-state when the controller is running in 1-phase CCM or DCM. This is used for normal inductor operating mode. 1: PWM6 pulls low while PWM1 is high when the controller is running in 1-phase CCM or DCM. This is used for coupled inductor operating mode. |
| 4 | COUPLE_INDUCTOR_EN | Enable bit for coupled inductor operating mode. 0: disable 1: enable |

c. By way of further example, Monolithic provides reference designs, evaluation boards, and evaluation tools to its customers that encourage infringing uses, sales, offers to sell, and importation of the Accused Products. As described above, since



2018, Monolithic has sold the MP2888A Digital, Multi-Phase PWM Controller with PMBus and PWM-VID, which “supports couple-inductor mode to reduce the overshoot during load releasing.” Monolithic supplies Evaluation Tools and Design Resources for this controller on its website. (<https://www.monolithicpower.com/en/mp2888a.html>). On information and belief, Monolithic provides similar Evaluation Tools and Design Resources for all of its controllers that support Couple Inductor mode. (See <https://www.monolithicpower.com/en/mp2965.html>).

- d. As another example, Monolithic coordinates with suppliers of coupled inductors to manufacture the coupled inductors included in the Accused Products. As described above, Monolithic reached out to [REDACTED] to request that [REDACTED] develop a coupled inductor for Monolithic’s use. On information and belief, Monolithic has coordinated with other suppliers of coupled inductors, including the supplier that provided the coupled inductors in the 48V-1V Power Solution for CPU, SoC or ASIC Controller that Monolithic demonstrated at APEC 2019.
- e. By way of further example, on information and belief, Monolithic representatives travel to customer sites for sales and support activity that includes working with customers and suppliers to facilitate these customers’ infringing testing, marketing, importation, and sales activity.
- f. On information and belief, Monolithic supplies its customers, distributors, and suppliers with the Accused Products so that they may be used, sold, offered for sale, and/or imported into the United States by those customers and suppliers.



25. Monolithic further contributes to the infringement of one or more claims of the '986 patent under 35 U.S.C. § 271(c) by offering to sell, selling, and/or importing into the United States a component of the Accused Products, or a material or apparatus for use in practicing a process claimed in the '986 patent, that constitutes a material part of the inventions, knowing the same to be especially made or especially adapted for use in an infringement of the '986 patent, and is not a staple article or commodity of commerce suitable for substantial noninfringing use.

- a. For example, on information and belief, Monolithic contributes to its customers' infringement of the '986 patent when it manufactures, designs, or assists in the design of a material part of the Accused Products. As discussed above, Monolithic manufactures the MP2888A and MP2965 controllers that are designed to operate in Couple Inductor mode. Monolithic makes the datasheets for each of these controllers publicly available, and these datasheets describe Couple Inductor mode and instruct customers how to program the controllers to operate in Couple Inductor mode.
- b. By way of further example, as discussed above, Monolithic provides reference designs, evaluation boards, and evaluation tools to its customers that comprise a material or apparatus for use in practicing a process claimed in the '986 patent.

26. The Accused Products meet all the limitations of at least claims 17–18, 20–21, and 23 of the '986 patent.

27. Claim 17 of the '986 patent recites: A method for reducing ripple in a DC-to-DC converter of the type producing an output voltage from an input voltage, comprising the steps of: orienting, in like direction, first and second windings about a common core to increase coupling

between the windings; and alternatively activating the first winding about 180 degrees out of phase with the second winding, to regulate magnitude of the output voltage.

28. The Accused Products perform a method for reducing ripple in a DC-to-DC converter of the type producing an output voltage from an input voltage. For example, at APEC 2019 Monolithic demonstrated a power converter that produces a 1 volt DC output voltage from a 48 volt DC input voltage. Further, Monolithic advertised the transient performance of the 2-stage structure. By using the methods of the '986 patent, the Accused Products achieve transient response optimization without incurring additional current ripple.

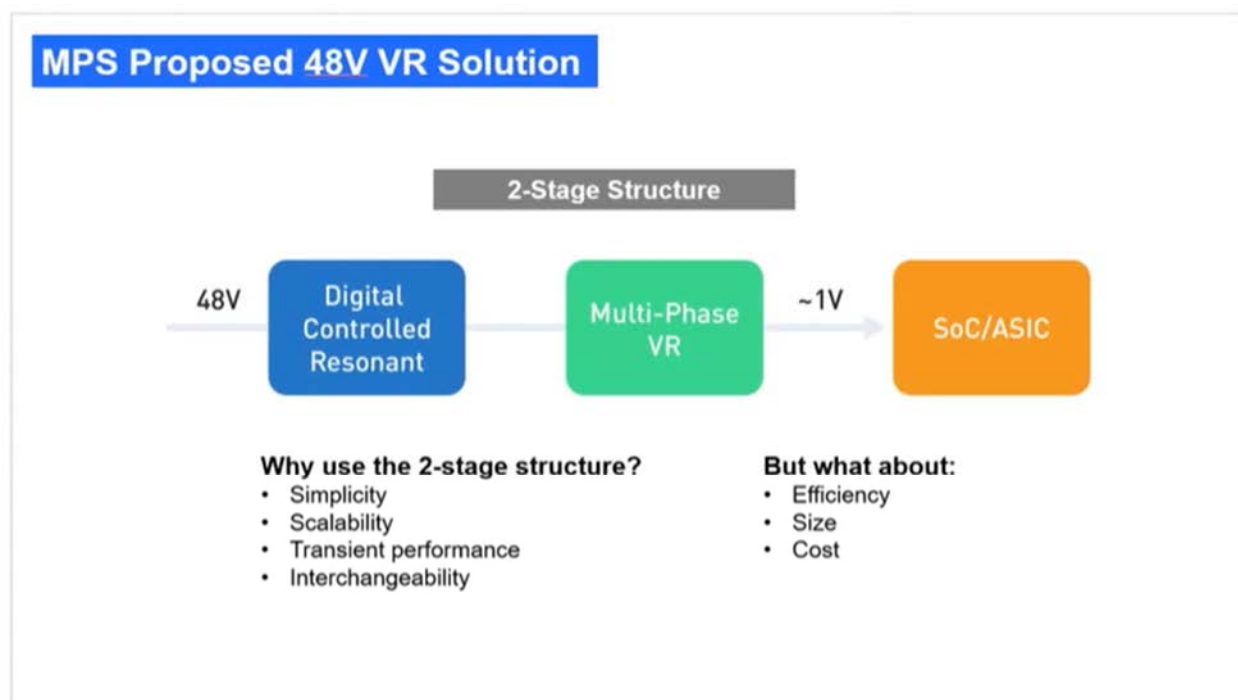

(<https://www.youtube.com/watch?v=w7CmBr1t3Ns>).

29. The Accused Products perform the method of claim 17 by orienting, in like direction, first and second windings about a common core to increase coupling between the windings. For example, the Accused Products include coupled inductors and each coupled

inductor includes first and second inductive windings oriented in a like direction about a common magnetic core to increase coupling between the windings.

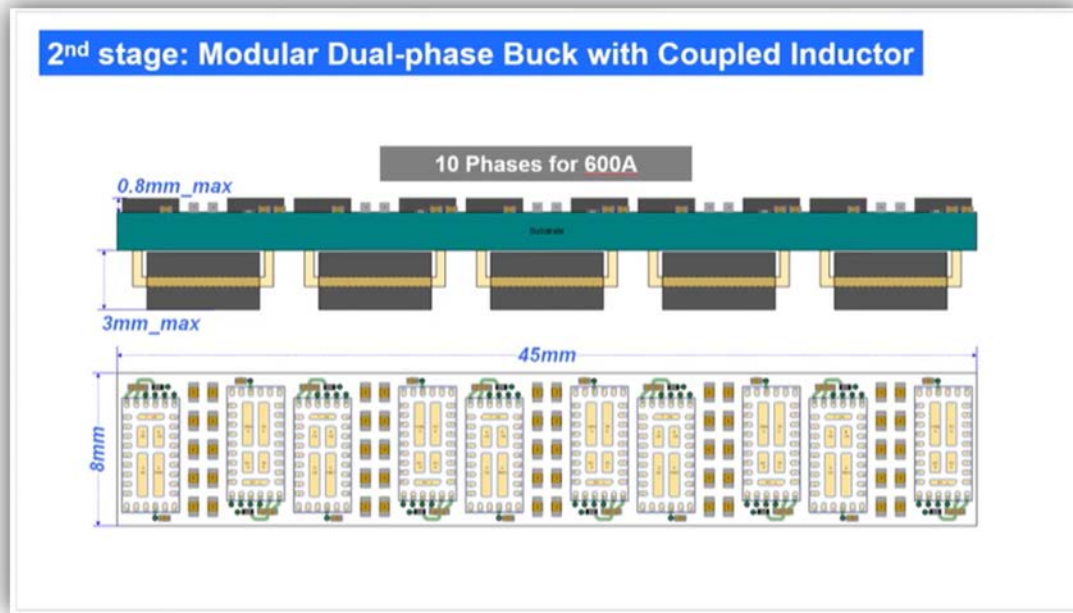

(<https://www.youtube.com/watch?v=w7CmBr1t3Ns>).

30. The Accused Products perform the method of claim 17 by alternatively activating the first winding about 180 degrees out of phase with the second winding, to regulate magnitude of the output voltage. For example, the Accused Products include a pair of control circuits for each dual-phase coupled inductor. In each pair of control circuits, the first control circuit is connected to the first winding and the second control circuit is connected to the second winding. The layout demonstrated at APEC 2019 is titled “Modular *Dual-phase* Buck with *Coupled Inductor*” and “*10 Phases* for 600A,” indicating that each of the five inductors pictured is a 2-phase coupled inductor such that the total amounts to “10 Phases.” Likewise, Monolithic’s demonstration at APEC 2019 discussed an 8-phase power converter, and the video displayed a board with four pairs of control circuits instead of the five pairs shown in the 10-phase layout. The layout and video both show the first control circuit’s physical orientation with respect to the second



control circuit, and the physical orientation of the control circuits is further evidence that each coupled inductor is a 2-phase coupled inductor. The use of 2-phase coupled inductors in the layout demonstrated at APEC 2019 is indicative of the first voltage across the first winding being switched at about 180 degrees out of phase with the second voltage across the second winding. The Accused Products switch the first voltage and second voltage to regulate the magnitude of the output voltage. For example, Monolithic demonstrated regulating an output voltage of 1 volt at APEC 2019.

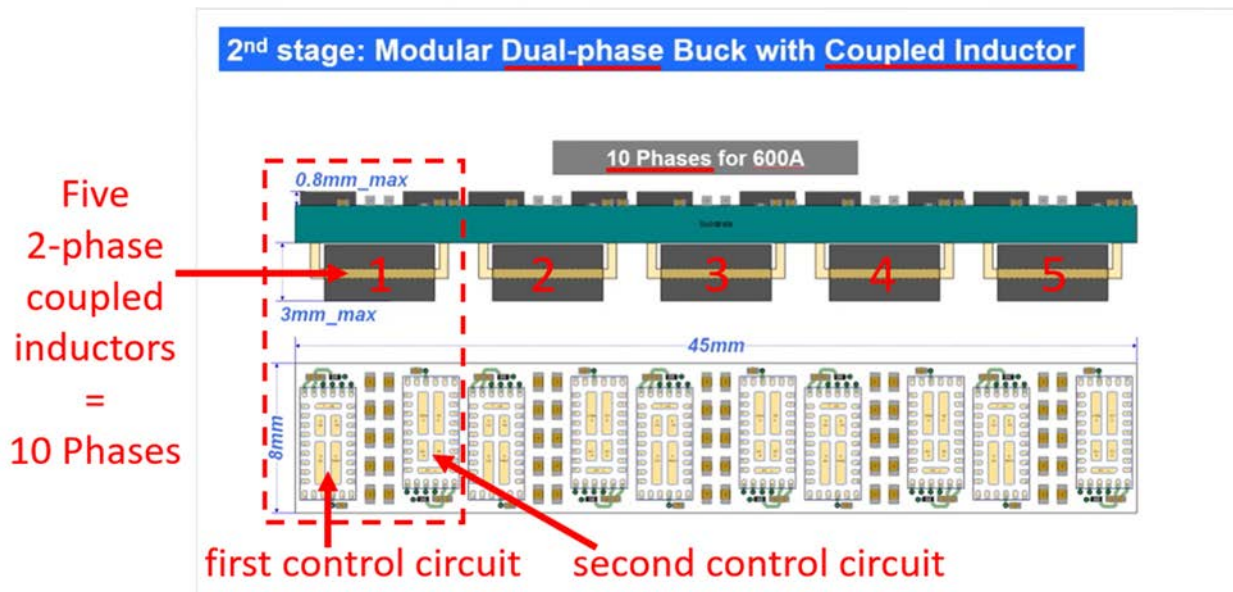

(<https://www.youtube.com/watch?v=w7CmBr1t3Ns> (annotation added)).

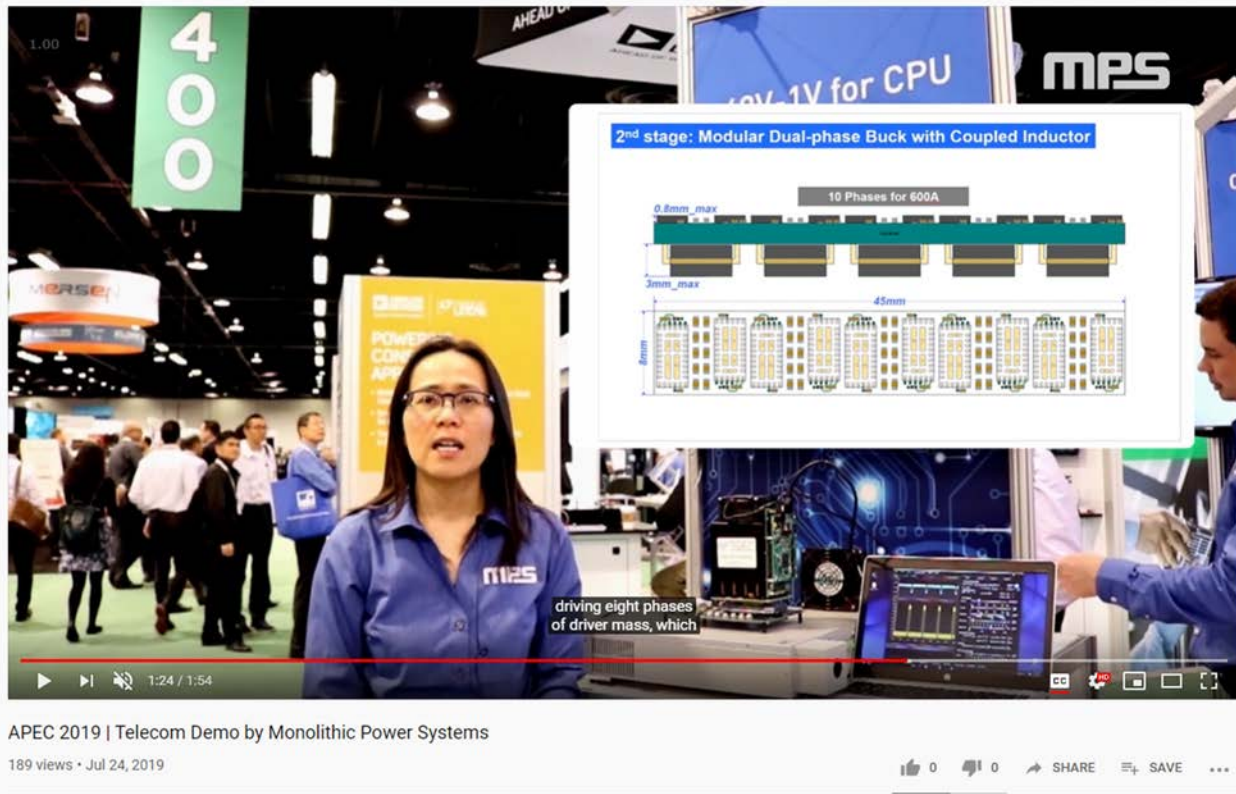

(<https://www.youtube.com/watch?v=w7CmBr1t3Ns>).

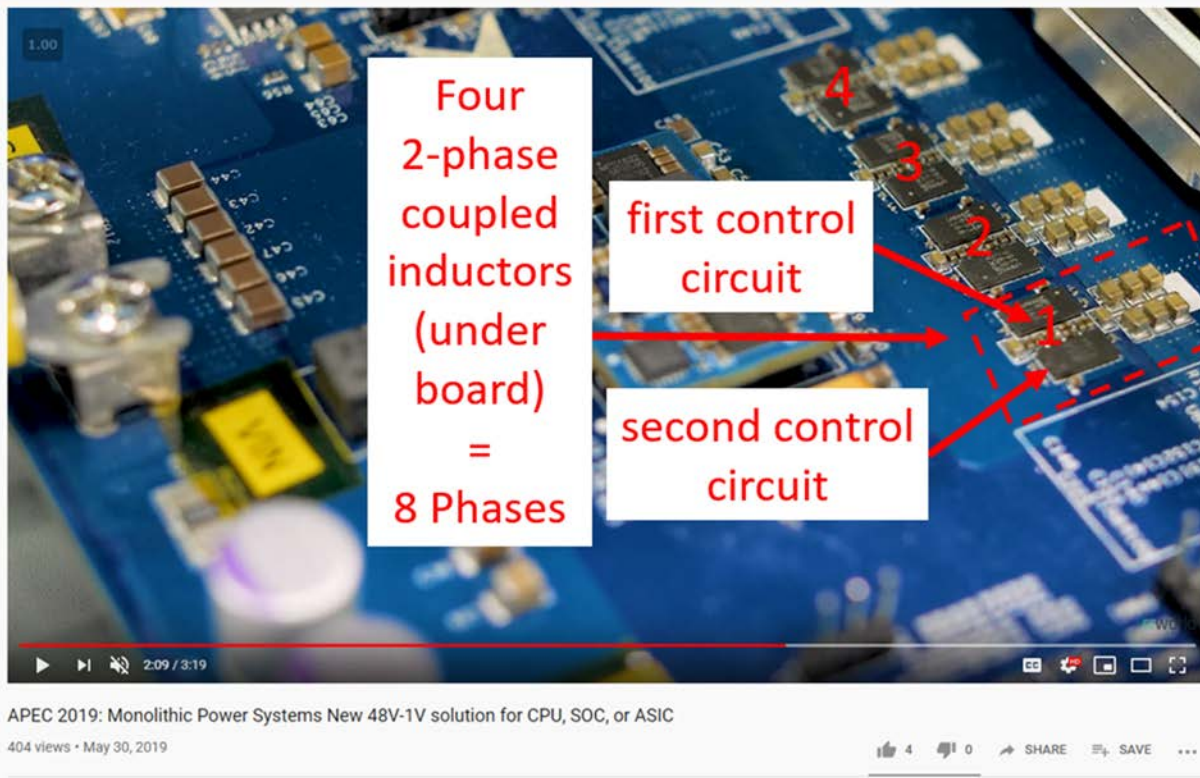



(<https://www.youtube.com/watch?v=WIC2SDWSins> (annotation added)).



(<https://www.youtube.com/watch?v=w7CmBr1t3Ns>).

31. Claim 18 of the '986 patent recites: A method of claim 17, further comprising switching the voltages across the windings by connecting one end of each winding to a common output voltage, and individually switching the other end of each winding between ground and an input voltage.

32. The Accused products perform the method of claim 17, further comprising switching the voltages across the windings by connecting one end of each winding to a common output voltage, and individually switching the other end of each winding between ground and an input voltage. For example, Monolithic demonstrated using a “Dual-phase Buck” converter to regulate an output voltage of 1 volt from an intermediate input voltage of 5–8 volts at APEC 2019. The layout demonstrated at APEC 2019 indicates the intermediate input voltage is switched across



the windings of the 2-phase coupled inductor by connecting one end of each winding to a common 1 volt output voltage and individually switching the other end of each winding between ground and the intermediate 5–8 volt input voltage.

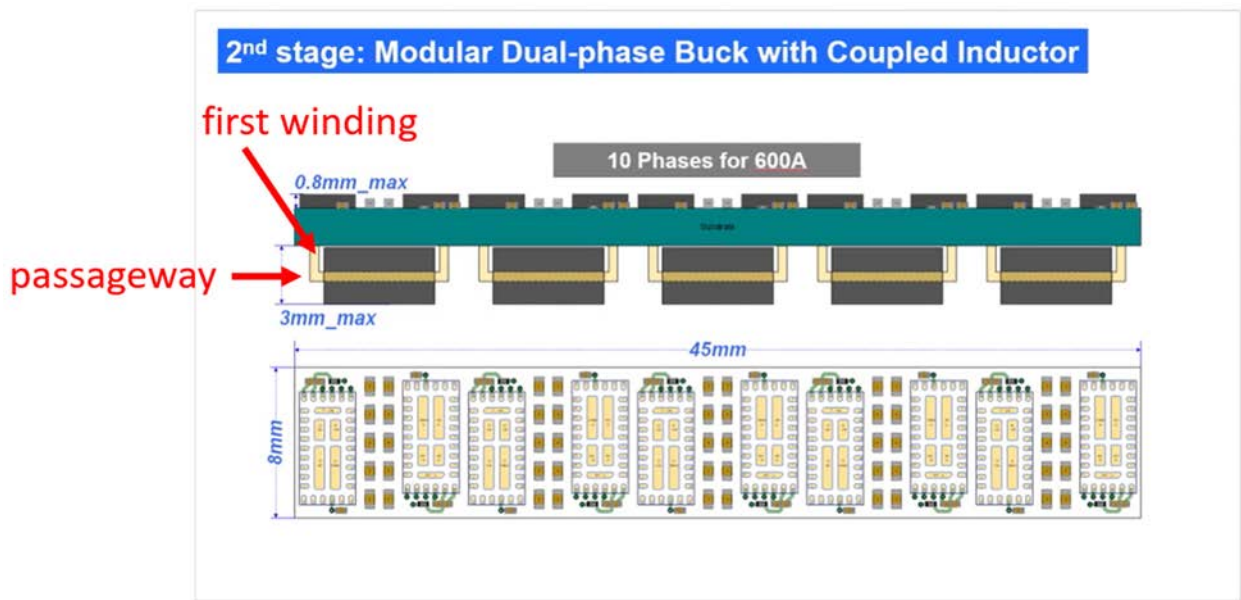

(<https://www.youtube.com/watch?v=w7CmBr1t3Ns> (annotation added)).

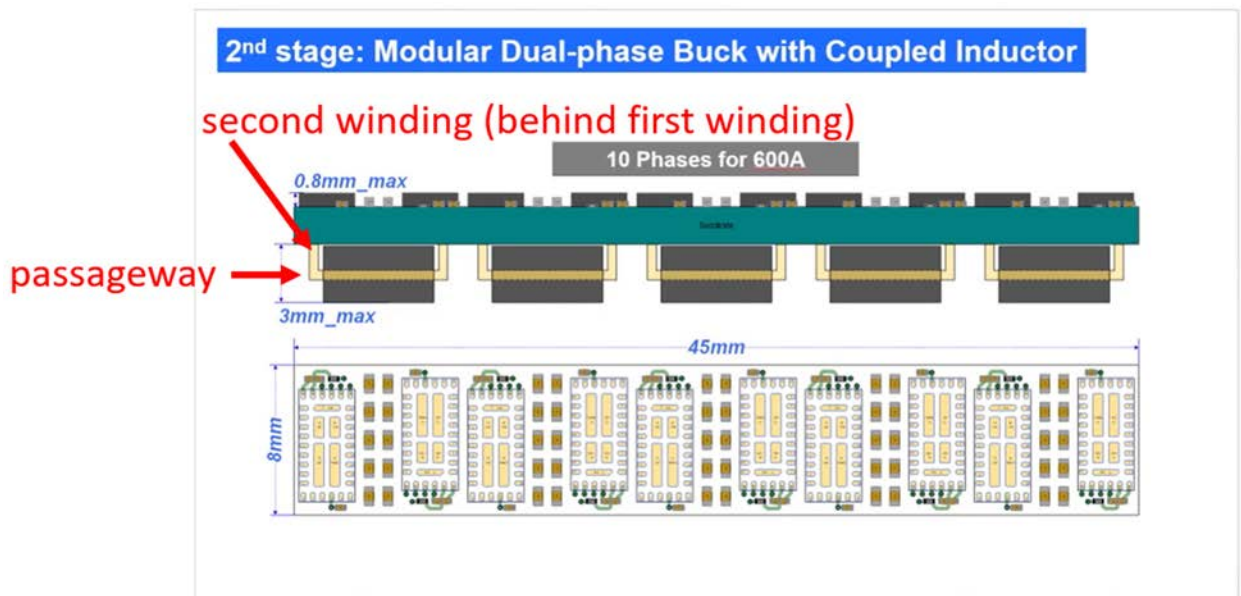

(<https://www.youtube.com/watch?v=w7CmBr1t3Ns> (annotation added)).



1.00

400

AHEAD OF

48V-1V for CPU or ASIC Power

MPS

POWERING CONSUMER APPLI...

PROVEN IN CENTER SOLUTIONS

48V-1V Power Solution for CPU, SoC or ASIC Controller

Our new 48 volt to 1 volt power solution

0:28 / 1:54

APEC 2019 | Telecom Demo by Monolithic Power Systems

294 views • Jul 24, 2019

0 0 SHARE SAVE ...

(<https://www.youtube.com/watch?v=w7CmBr1t3Ns>).

1.00

400

AHEAD OF

48V-1V for CPU

MPS

POWERING CONSUMER APPLI...

PROVEN IN CENTER SOLUTIONS

1st stage: 300W Module 3D View

27mm

6mm

Magnetic Core

18mm

Magnetic Core

48V converted down to intermediate voltage: 5V-8V

0:49 / 1:54

APEC 2019 | Telecom Demo by Monolithic Power Systems

297 views • Jul 24, 2019

0 0 SHARE SAVE ...



(<https://www.youtube.com/watch?v=w7CmBr1t3Ns>).

33. Claim 20 of the '986 patent recites: The method of claim 17, further comprising the step of activating one or more of the windings at a selected duty cycle.

34. The Accused Products perform the method of claim 17, further comprising activating one or more of the windings at a selected duty cycle. For example, Monolithic demonstrated using a “Dual-phase Buck” converter to regulate an output voltage of 1 volt from an intermediate input voltage of 5–8 volts at APEC 2019. The layout indicates the first and second winding are activated at a selected duty cycle to regulate a 1 volt output voltage from the intermediate 5–8 volt input voltage. For example, the intermediate input voltage is switched across the windings of the 2-phase coupled inductor by connecting one end of each winding to a common 1 volt output voltage and individually switching the other end of each winding between ground and the intermediate 5–8 volt input voltage.

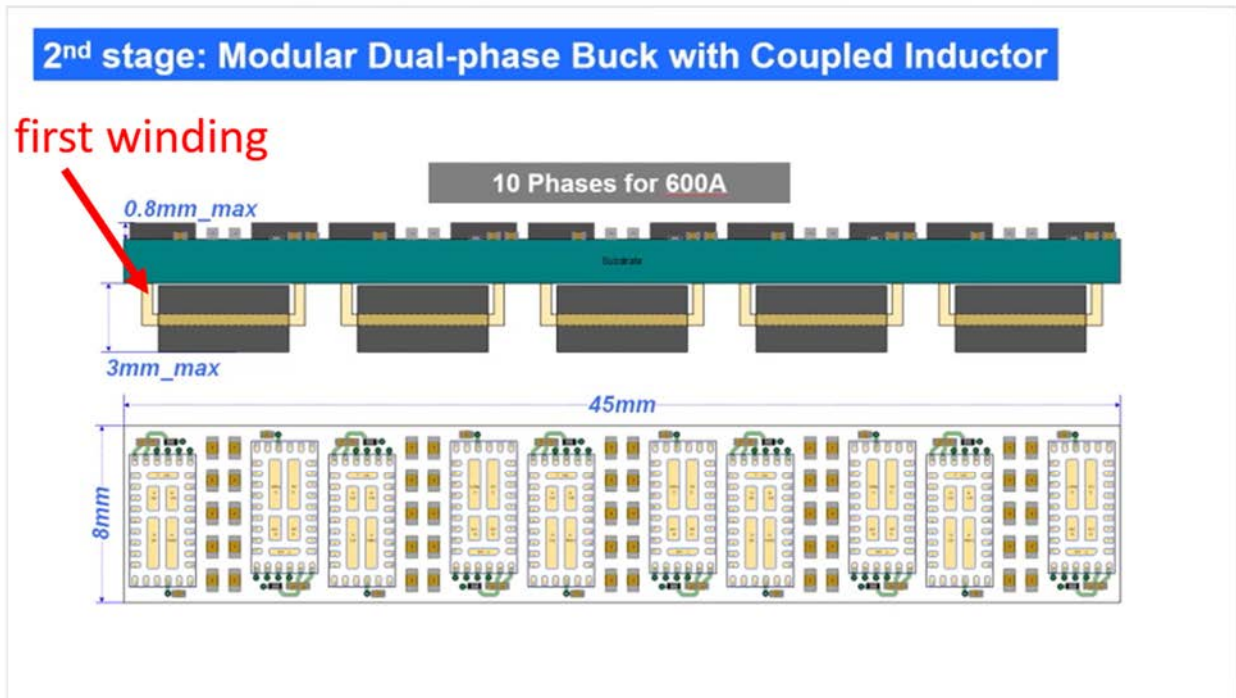

(<https://www.youtube.com/watch?v=w7CmBr1t3Ns> (annotation added)).

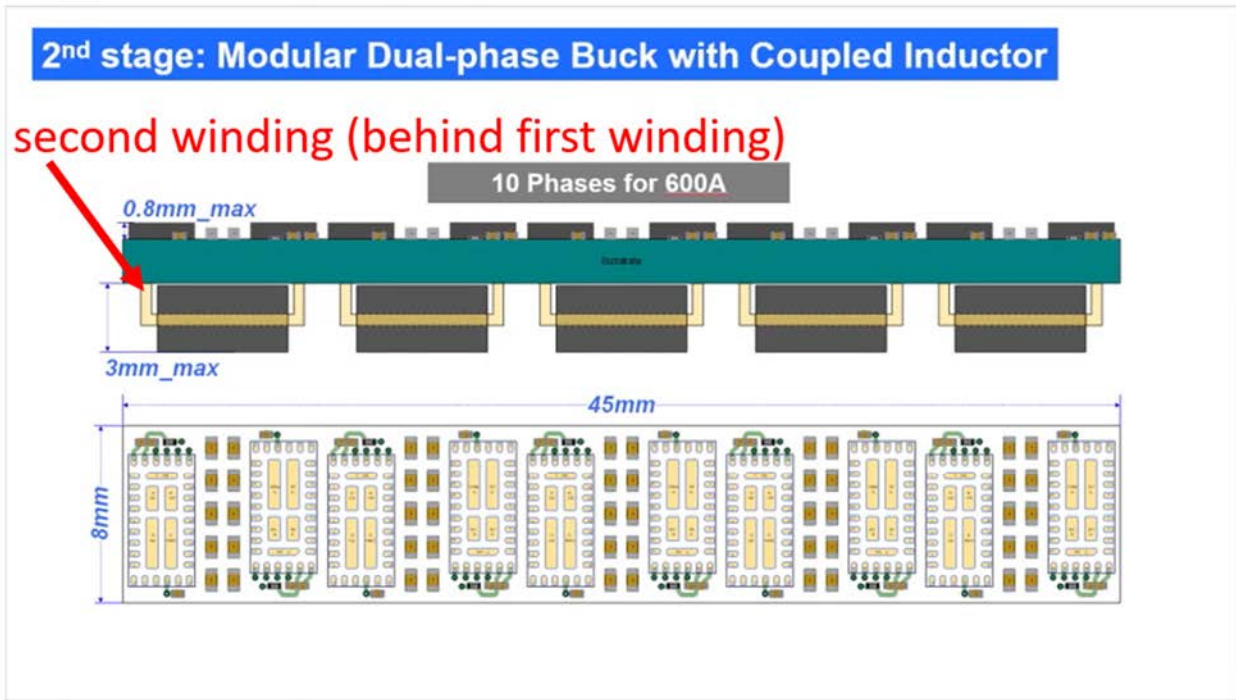

(<https://www.youtube.com/watch?v=w7CmBr1t3Ns> (annotation added)).

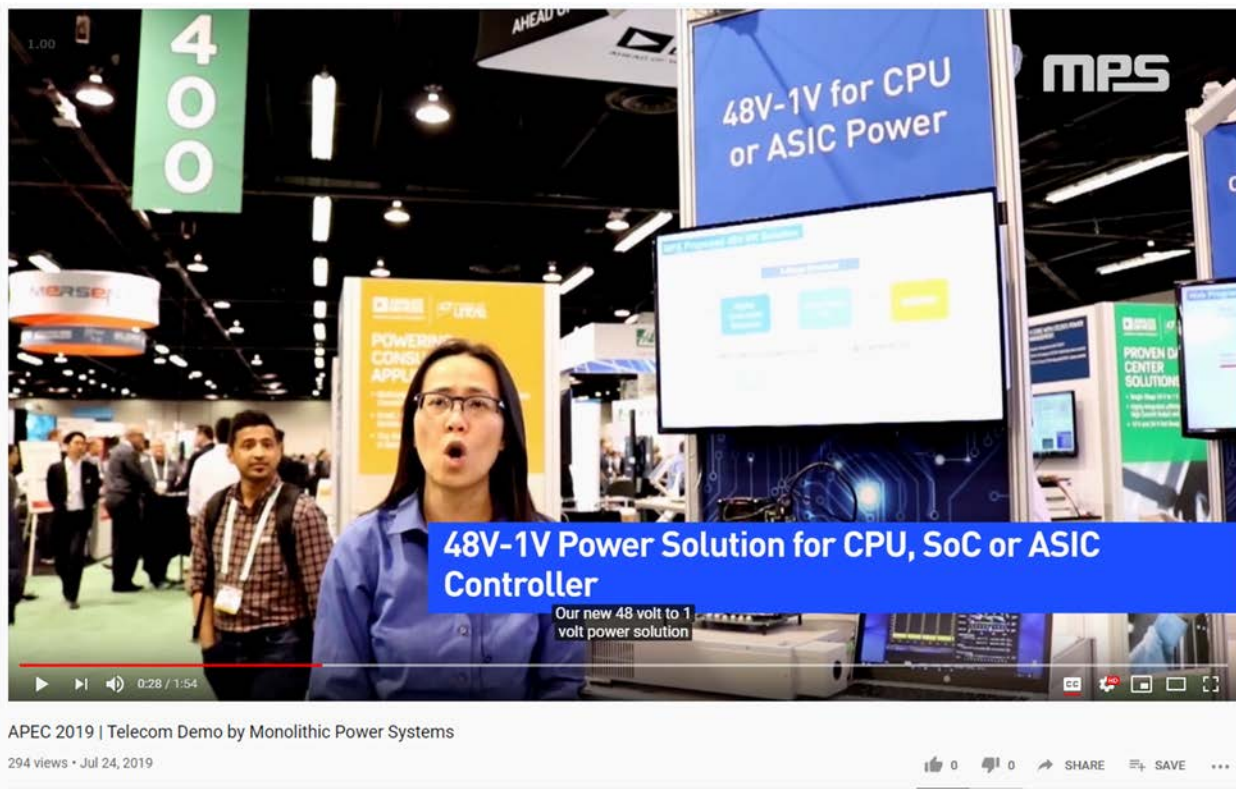

(<https://www.youtube.com/watch?v=w7CmBr1t3Ns>).

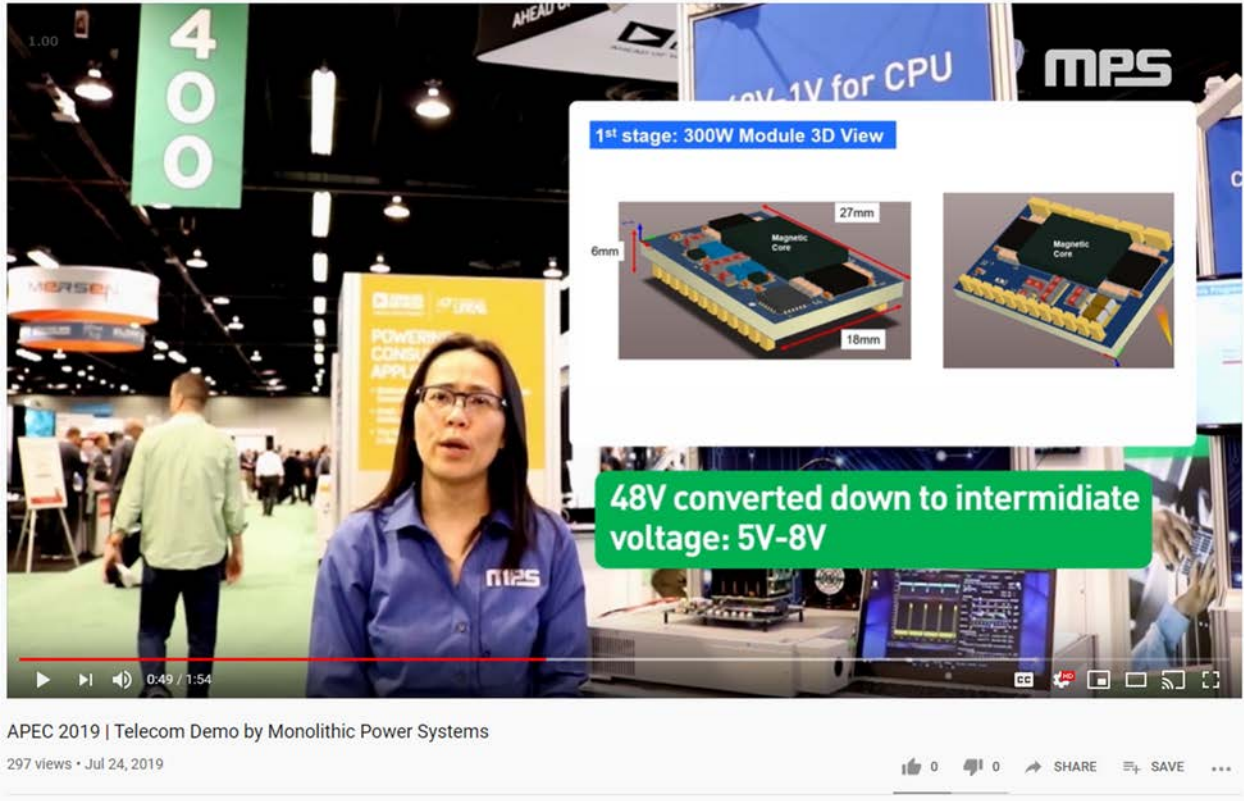

(<https://www.youtube.com/watch?v=w7CmBr1t3Ns>).

35. Claim 21 of the '986 patent recites: The method of claim 20, wherein the step of activating comprises activating the windings at a duty cycle between about 5% and 90%.

36. The Accused Products practice the method of claim 20, wherein the step of activating comprises activating the windings at a duty cycle between about 5% and 90%. For example, Monolithic demonstrated using a “Dual-phase Buck” converter to regulate an output voltage of 1 volt from an intermediate input voltage of 5–8 volts at APEC 2019. The layout indicates the first and second winding are activated at a duty cycle equal to the 1 volt output voltage divided by the intermediate 5–8 volt input voltage. As such, the duty cycle is between 12.5% and 20%.

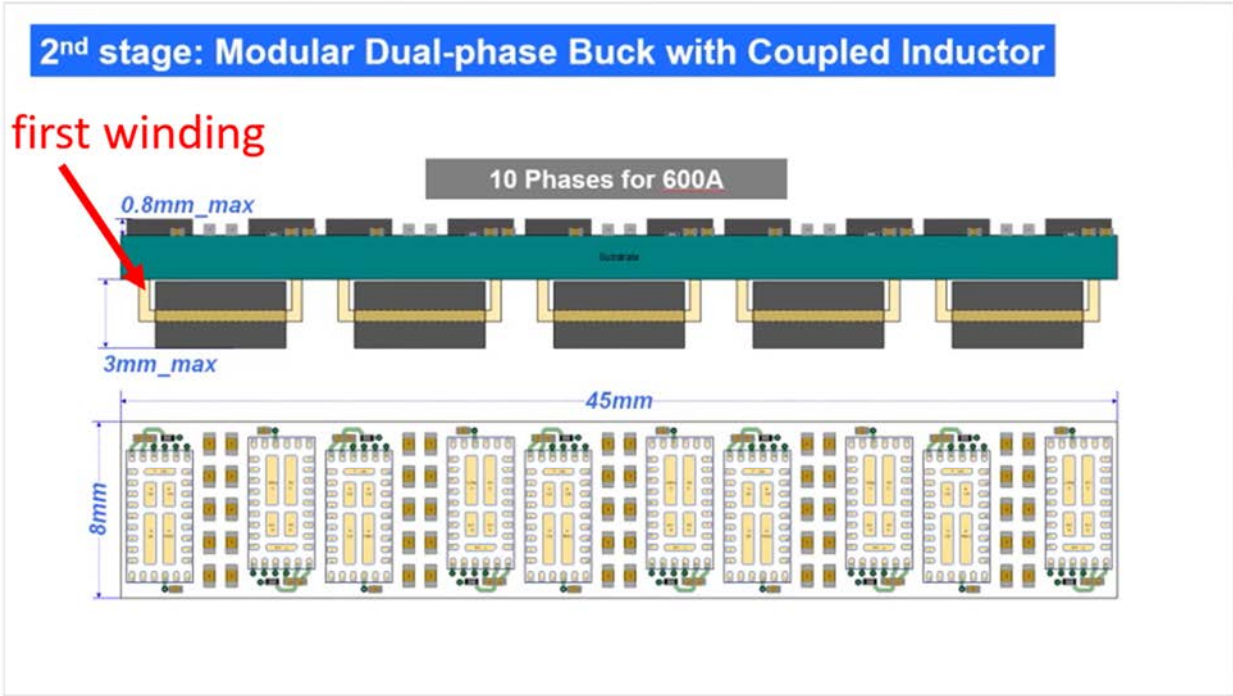

(<https://www.youtube.com/watch?v=w7CmBr1t3Ns> (annotation added)).

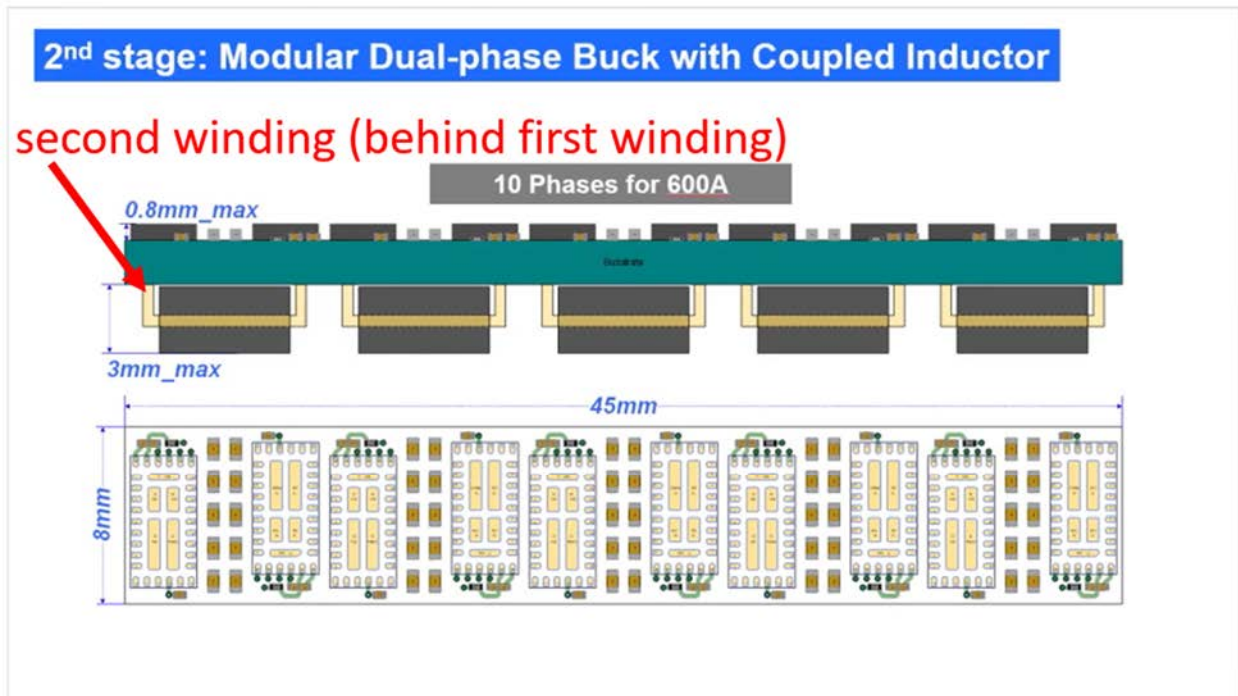

(<https://www.youtube.com/watch?v=w7CmBr1t3Ns> (annotation added)).



400

48V-1V for CPU or ASIC Power

MPS

POWERING CONSUMER APPLICATIONS

PROVEN IN CENTER SOLUTIONS

48V-1V Power Solution for CPU, SoC or ASIC Controller

Our new 48 volt to 1 volt power solution

APEC 2019 | Telecom Demo by Monolithic Power Systems

294 views • Jul 24, 2019

0:28 / 1:54

0 0 SHARE SAVE ...

(<https://www.youtube.com/watch?v=w7CmBr1t3Ns>).

400

48V-1V for CPU

MPS

POWERING CONSUMER APPLICATIONS

PROVEN IN CENTER SOLUTIONS

1st stage: 300W Module 3D View

6mm

27mm

18mm

Magnetic Core

Magnetic Core

48V converted down to intermediate voltage: 5V-8V

APEC 2019 | Telecom Demo by Monolithic Power Systems

297 views • Jul 24, 2019

0:49 / 1:54

0 0 SHARE SAVE ...



(<https://www.youtube.com/watch?v=w7CmBr1t3Ns>).

37. Claim 23 of the '986 patent recites: The method of claim 17, further comprising the steps of forming a first number of turns in the first winding and a second number of turns in the second winding.

38. The Accused Products perform the method of claim 17 by forming a first number of turns in the first winding and a second number of turns in the second winding. For example, the layout demonstrated at APEC 2019 indicates the first and second windings are single turn windings.

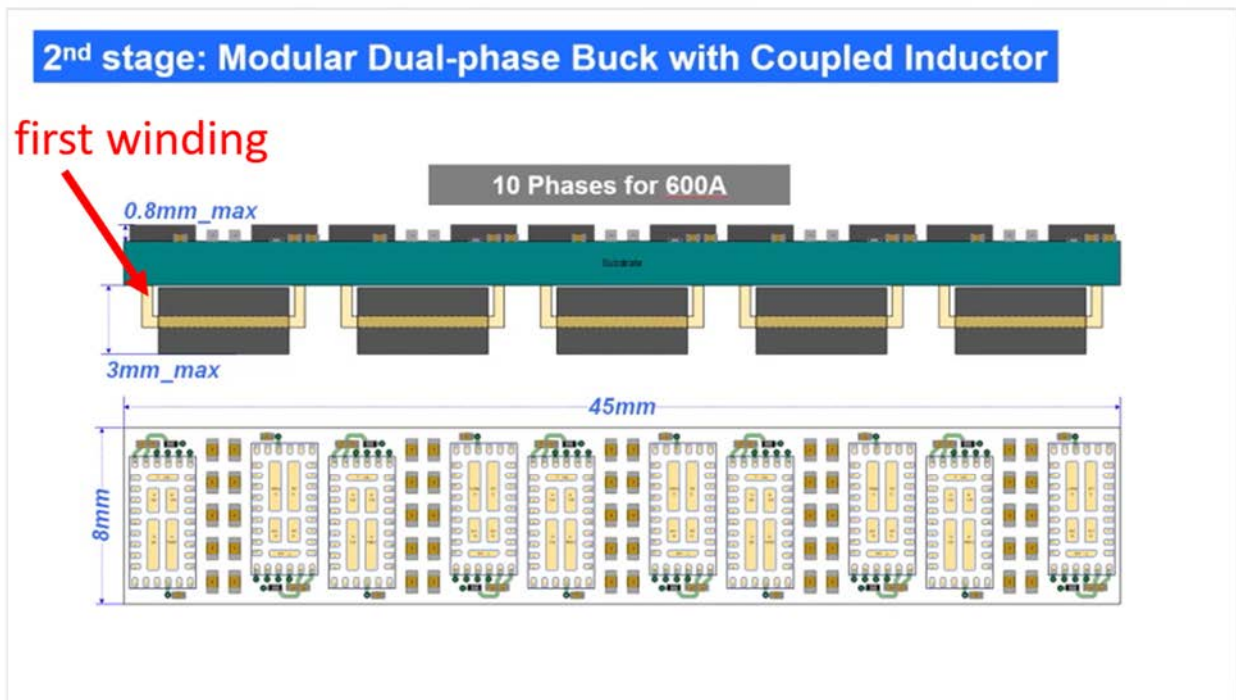

(<https://www.youtube.com/watch?v=w7CmBr1t3Ns> (annotation added)).

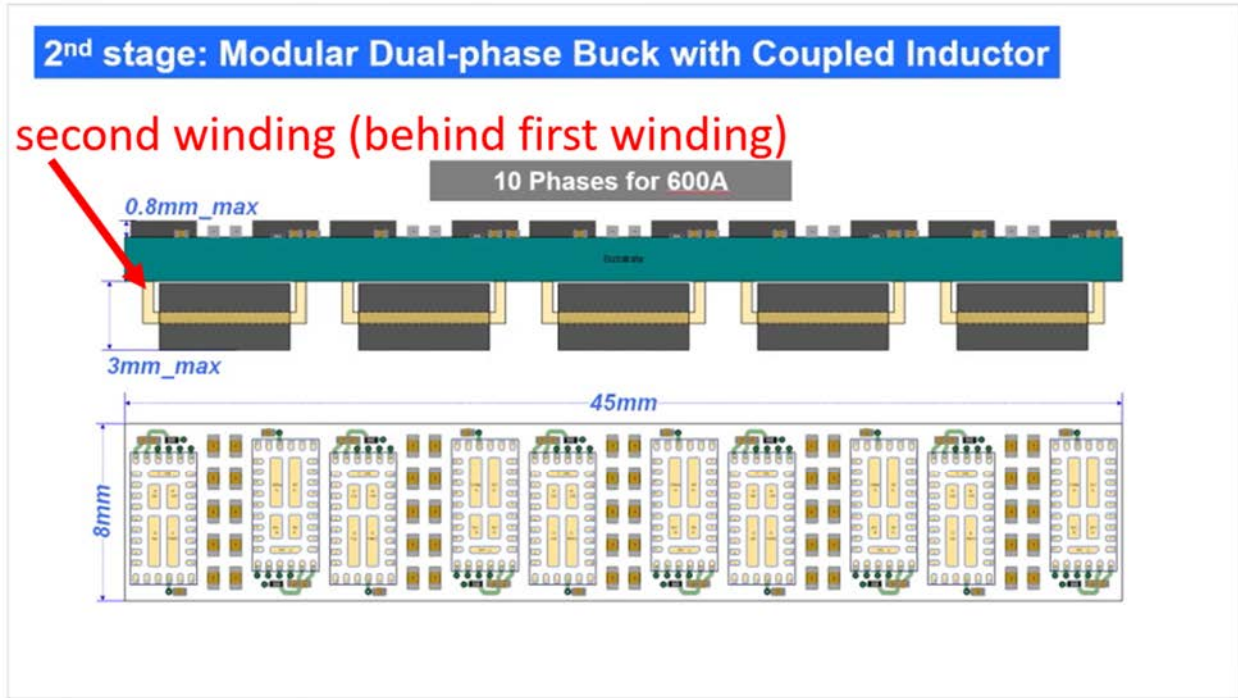

(<https://www.youtube.com/watch?v=w7CmBr1t3Ns> (annotation added)).

39. This description is based on publicly available information and a reasonable investigation of the structure and operation of the Accused Products. Volterra reserves the right to modify this description, including, for example, on the basis of information about the Accused Products that it obtains during discovery.

40. Monolithic’s infringement has damaged and continues to damage Volterra in an amount yet to be determined, of at least a reasonable royalty and/or the lost profits that Volterra would have made but for Monolithic’s acts of infringement.

41. This is an exceptional case. Volterra is entitled to attorneys’ fees and costs under 35 U.S.C. § 285 as a result of the infringement of the ’986 patent by Monolithic.

42. Volterra has no adequate remedy at law for Monolithic’s infringement. As a direct and proximate result of Monolithic’s acts of infringement, Volterra has suffered and continues to



suffer damages and irreparable harm. Unless Monolithic's acts of infringement are enjoined by the Court, Volterra will continue to be damaged and irreparably harmed.

COUNT II: INFRINGEMENT OF U.S. PATENT NO. 7,525,408

43. Volterra incorporates by reference and realleges all the foregoing paragraphs of this Complaint as if fully set forth herein.

44. On information and belief, Monolithic has directly infringed, continues to infringe, and/or has induced or contributed to the infringement of at least claims 14 and 20 of the '408 patent by making, using, selling, offering for sale, and/or importing into the United States, without authority or license, the Accused Products in violation of 35 U.S.C. § 271(a). For example, Monolithic directly infringed the '408 patent when it demonstrated its 48V-1V Power Solution for CPU, SoC or ASIC Controller at APEC 2019.

45. Monolithic has had knowledge of the '408 patent and that its activities infringe the '408 patent long before the filing of this action. Specifically, the follow activities demonstrate Monolithic's *presuit* knowledge and intent regarding the '408 patent:

- a. As described above with respect to the '986 patent, Monolithic specifically discussed the Volterra patent portfolio related to coupled inductor based voltage converters with [REDACTED] in approximately June 2019. Monolithic expressed to [REDACTED] that it did not feel that the Volterra patents would be a problem for at least the reason that the patents would be expiring soon. The '986 patent is the first patent to expire in the Volterra patent portfolio related to coupled inductor based voltage converters. The '408 patent shares a common inventor with the '986 patent and will expire 25 months after the '986 patent. As such, the reference by Monolithic to expiring Volterra patents evidences Monolithic's knowledge and intent regarding at least the '408 patent.

██

- b. As described above with respect to the '986 patent, in the third quarter of 2019, prior to the filing of the Complaint, component manufacturer ██████ asked Monolithic about Volterra's coupled inductor patents and asked if Monolithic could satisfy ██████ that there would not be infringement of the Volterra patents related to voltage converters based on a coupled inductor architecture. On information and belief, Monolithic did not respond to ██████ request or otherwise satisfy ██████ inquiry.

- c. As described above with respect to the '986 patent, during the course of Monolithic's work with potential customer ██████ in 2018, an ██████ engineer raised Volterra's coupled inductor patents with Monolithic.

- d. As described above with respect to the '986 patent, technical publications by Monolithic engineers, including at least one who has submitted a declaration in this case regarding the products at issue, show that Monolithic specifically was familiar with Volterra's coupled inductor patents. This is not surprising because Volterra's coupled inductor patents are widely known in this industry. Multiple Monolithic senior engineers have written technical papers in which they discussed the Volterra patented designs at length.
 - i. As discussed above with respect to the '986 patent, Mr. Zhou claimed to “communicate regularly with customers about MPS products and opportunities to work together on products.” (D.I. 43 at ¶ 1). Mr. Zhou's declaration also illustrates his familiarity with the controllers and coupled inductors at issue in this case. Mr. Zhou's dissertation analyzed what he called the “scalable multi-phase surface mount coupling inductor structure

proposed by Volterra.” To illustrate what he meant by the structure proposed by Volterra, Mr. Zhou cited the ’986 patent. The ’408 patent shares an inventor with the ’986 patent and devotes multiple paragraphs to the ’986 patent in the Background of the Invention section, indicating that the patents are related and would be discussed together. Mr. Zhou’s dissertation also cited multiple related papers by the inventors of the ’986 patent, including Charles R. Sullivan—an inventor of the ’408 patent. The dissertation also cites to several other papers by Mr. Sullivan, evidencing that Mr. Zhou was very familiar with his work. An excerpt from the dissertation along with the citations is shown below:

Based on this understanding, a scalable multi-phase surface mount coupling inductor structure is proposed by [77, 78], as shown in Figure 4.15. For each phase, there is one copper winding around the H-core so that the leg for leakage flux path (center leg in Figure 4.1) is eliminated.

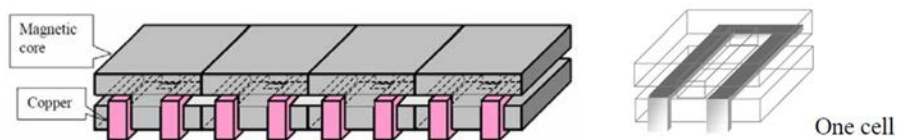

Figure 4.15 A scalable multi-phase surface mount coupling inductor structure proposed by Volterra in [77]

- [55] B. Acker, C. Sullivan and S. Sanders, “Current Controlled Synchronous Rectification,” IEEE APEC, 1994, pp. 185-191.
- [76] Jieli Li; Sullivan, C.R.; Schultz, A., “Coupled-inductor design optimization for fast-response low-voltage DC-DC converters,” APEC 2002. Seventeenth Annual IEEE, Volume: 2, 10-14 March 2002, Pages: 817 – 823.
- [77] Jieli Li, Schultz, A., Stratakos, A., Sullivan, C.R., “Using Coupled Inductors to Enhance Transient Performance of Multi-Phase Buck Converters,” APEC 2004. Seventeenth Annual IEEE, Volume: 2, 10-14 March 2002, Pages: 817 – 823.
- [78] Aaron M. Schultz, Charles R. Sullivan, “Voltage Converter with Coupled Inductive Windings, and Associated Methods,” U. S. Patent 6362986 B1, March 26, 2002.
- [98] L. Daniel, C. R. Sullivan and S. R. Senders, “Design of Microfabricated Inductors,” Proc. IEEE PESC, 1996, pp. 1447-1455.

[120] C.J. Mehas, K.D. Coonley and C.R. Sullivan, "Converter and inductor design for fast-response microprocessor power delivery," in Proc. IEEE PESC, 2000, pp. 1621-1626.

- ii. Mr. Dong's Dissertation discussed Volterra's inventions and cited papers written by Mr. Sullivan. Indeed, Mr. Dong recognized that "C. Sullivan developed the **n-phase coupled-inductor buck converter** analysis when the duty cycle D is less than $1/n$." The '408 patent is entitled "Method for making magnetic components with **N-phase coupling**, and related inductor structures" and "relates to construction of a **coupled inductor within a multi-phase DC-to-DC converter**." Mr. Dong also analyzed "C. Sullivan's two-phase coupled-inductor structure" and "C. Sullivan's three-phase coupled-inductor and its magnetic paths." Like Mr. Zhou, Mr. Dong's dissertation cites to several papers by Mr. Sullivan, evidencing that Mr. Zhou was very familiar with his work.

[14] G. J. Mehas, K. D. Coonley and C. R. Sullivan, "Converter and inductor design for fast-response microprocessor power delivery," Proc. of IEEE PESC, 2001, pp. 1621-1626.

[40] J. Li, A. Stratakos, A. Schultz, C. R. Sullivan, "Using coupled-inductors to enhance transient performance of multi-phase buck converters," in Proc. IEEE APEC '04, Feb. 22-26, 2004, Anaheim, CA, pp. 1289-1293.

[41] Jieli Li, Charles R. Sullivan, Aaron Schultz, "Coupled-inductor design optimization for fast-response low-voltage DC-DC converters", in Proceedings of APEC 2002 - Applied Power Electronics Conf., pp. 817-823 vol.2.

[42] A. M. Schultz and C. R. Sullivan, "Voltage converter with coupled inductive windings and associated methods", U.S. Patent 6,362,986, Mar. 26, 2002, Volterra Semiconductor Corp.

[53] Jieli Li, T. Abdallah, and C.R. Sullivan, "Improved calculation of core loss with non-sinusoidal waveforms", in Proc. IEEE IAS 2001, pp.2203-2210.

[54] A. Hoke and C. R. Sullivan, "An Improved two-dimensional numerical modeling method for E-core transformers," in Proc. IEEE APEC '02, Mar. 10-14, 2002, Dallas, TX, pp. 151 - 157.

- e. Finally, Volterra realleges that Monolithic's knowledge and intent is further demonstrated by post-suit activity. By at least December 9, 2019, Volterra



disclosed, at least by filing its Complaint, the existence of the '408 patent and identified at least some of Monolithic's and others' activities that infringe the '408 patent. Thus, based on this disclosure, Monolithic had knowledge of the '408 patent and that its activities infringe the '408 patent since at least December 9, 2019. Based on Volterra's disclosures, Monolithic has also known or should have known since at least December 9, 2019 that its customers, distributors, suppliers, and other purchasers of the Accused Products are infringing the '408 patent at least because Monolithic has known that it is infringing the '408 patent.

46. Monolithic also actively, knowingly, and intentionally induces infringement of one or more claims of the '408 patent under 35 U.S.C. § 271(b) by actively encouraging others to import into the United States, and/or make, use, sell, and/or offer to sell in the United States, the Accused Products or products containing the infringing components of the Accused Products.

- a. For example, Monolithic actively promotes the sale, use, and importation of the Accused Products in marketing materials and videos made available on its YouTube channel (e.g., www.youtube.com/channel/UCqOx8jWRKEq4TpfCjCz0Isw) as well as at trade shows (e.g., APEC 2019) and through its sales and distribution channels that encourage infringing uses, sales, offers to sell, and importation of the Accused Products.
- b. As another example, Monolithic designs controllers that operate in a Couple Inductor mode, including the MP2888A controller and the MP2965 controller. As described above with respect to the '986 patent, Monolithic makes the datasheets for each of these controllers publicly available, and these datasheets describe



Couple Inductor mode and instruct customers how to program the controllers to operate in Couple Inductor mode.

- c. By way of further example, Monolithic provides reference designs, evaluation boards, and evaluation tools to its customers that encourage infringing uses, sales, offers to sell, and importation of the Accused Products. As described above, since 2018, Monolithic has sold the MP2888A Digital, Multi-Phase PWM Controller with PMBus and PWM-VID, which “supports couple-inductor mode to reduce the overshoot during load releasing.” Monolithic supplies Evaluation Tools and Design Resources for this controller on its website. (<https://www.monolithicpower.com/en/mp2888a.html>). On information and belief, Monolithic provides similar Evaluation Tools and Design Resources for all of its controllers that support Couple Inductor mode. (See <https://www.monolithicpower.com/en/mp2965.html>).
- d. As another example, Monolithic coordinates with suppliers of coupled inductors to manufacture the coupled inductors included in the Accused Products. As described above, Monolithic reached out to [REDACTED] to request that [REDACTED] develop a coupled inductor for Monolithic’s use. On information and belief, Monolithic has coordinated with other suppliers of coupled inductors, including the supplier that provided the coupled inductors in the 48V-1V Power Solution for CPU, SoC or ASIC Controller that Monolithic demonstrated at APEC 2019.
- e. As another example, on information and belief, Monolithic representatives travel to customer sites for sales and support activity that includes working with

[REDACTED]

customers and suppliers to facilitate these customers' infringing testing, marketing, importation, and sales activity.

- f. On information and belief, Monolithic supplies its customers, distributors, and suppliers with the Accused Products so that they may be used, sold, offered for sale, and/or imported into the United States by those customers and suppliers.

47. Monolithic further contributes to the infringement of one or more claims of the '408 patent under 35 U.S.C. § 271(c) by offering to sell, selling, and/or importing into the United States a component of the Accused Products, or a material or apparatus for use in practicing a process claimed in the '408 patent, that constitutes a material part of the inventions, knowing the same to be especially made or especially adapted for use in an infringement of the '408 patent, and is not a staple article or commodity of commerce suitable for substantial noninfringing use.

- a. For example, on information and belief, Monolithic contributes to its customers' infringement of the '408 patent when it manufactures, designs, or assists in the design of a material part of the Accused Products. As discussed above, Monolithic manufactures the MP2888A and MP2965 controllers that are designed to operate in Couple Inductor mode. Monolithic makes the datasheets for each of these controllers publicly available, and these datasheets describe Couple Inductor mode and instruct customers how to program the controllers to operate in Couple Inductor mode.
- b. By way of further example, as discussed above, Monolithic provides reference designs, evaluation boards, and evaluation tools to its customers that comprise a component of an apparatus claimed in the '408 patent.



48. The Accused Products meet all the limitations of at least claims 14 and 20 of the '408 patent.

49. Claim 14 of the '408 patent recites: An N-phase coupled inductor for magnetically coupling N phases of a power converter, comprising: a magnetic core including a first and a second magnetic element and N connecting magnetic elements, N being an integer greater than one, the first and second magnetic elements being disposed parallel to each other and separated by a linear separation distance, each connecting magnetic element being coupled to the first and second magnetic elements, the first and second magnetic elements and the N connecting elements cooperatively forming N-1 passageways; and N windings, each of the N windings for electrically connecting to a respective phase of the power converter, each winding being wound about a respective connecting element and at least partially through at least one passageway, and each passageway having two of the N windings wound at least partially therethrough.

50. The Accused Products include an N-phase coupled inductor for magnetically coupling N phases of a power converter. For example, the Accused Products include multiple 2-phase coupled inductors for magnetically coupling 2 phases of a DC-to-DC power converter. Monolithic's demonstration at APEC 2019 discussed an 8-phase power converter and included a layout of a 10-phase power converter. The layout of the 10-phase power converter showed five 2-phase coupled inductors. Likewise, the video displayed an 8-phase power converter's board with four pairs of control circuits instead of the five pairs shown in the 10-phase layout.

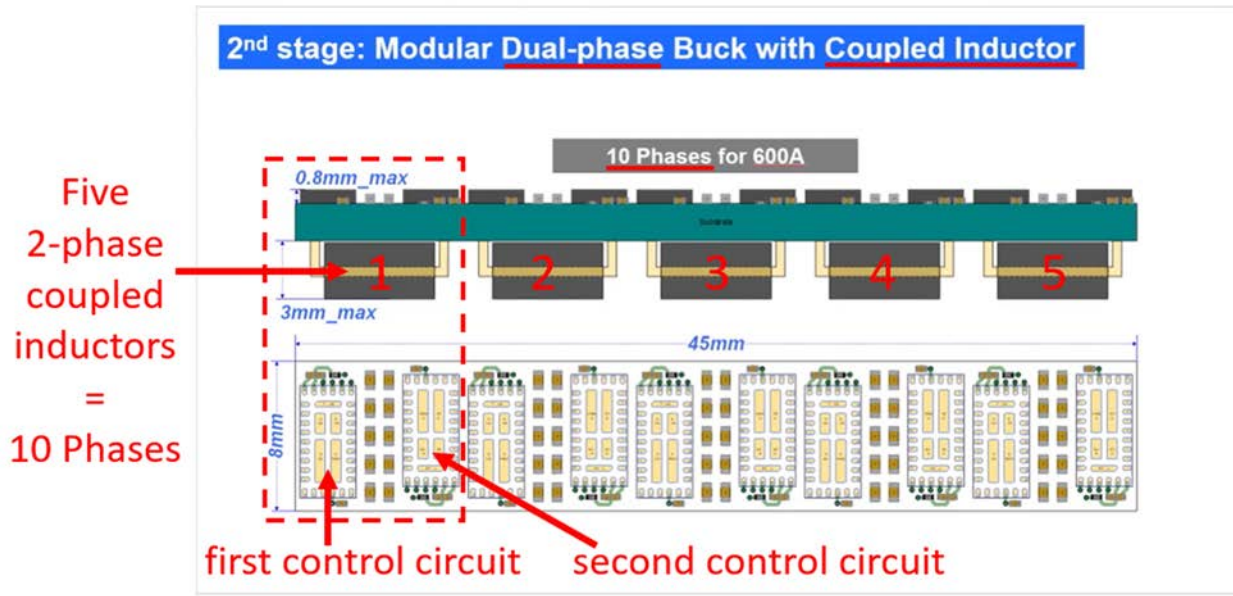

(<https://www.youtube.com/watch?v=w7CmBr1t3Ns> (annotation added)).

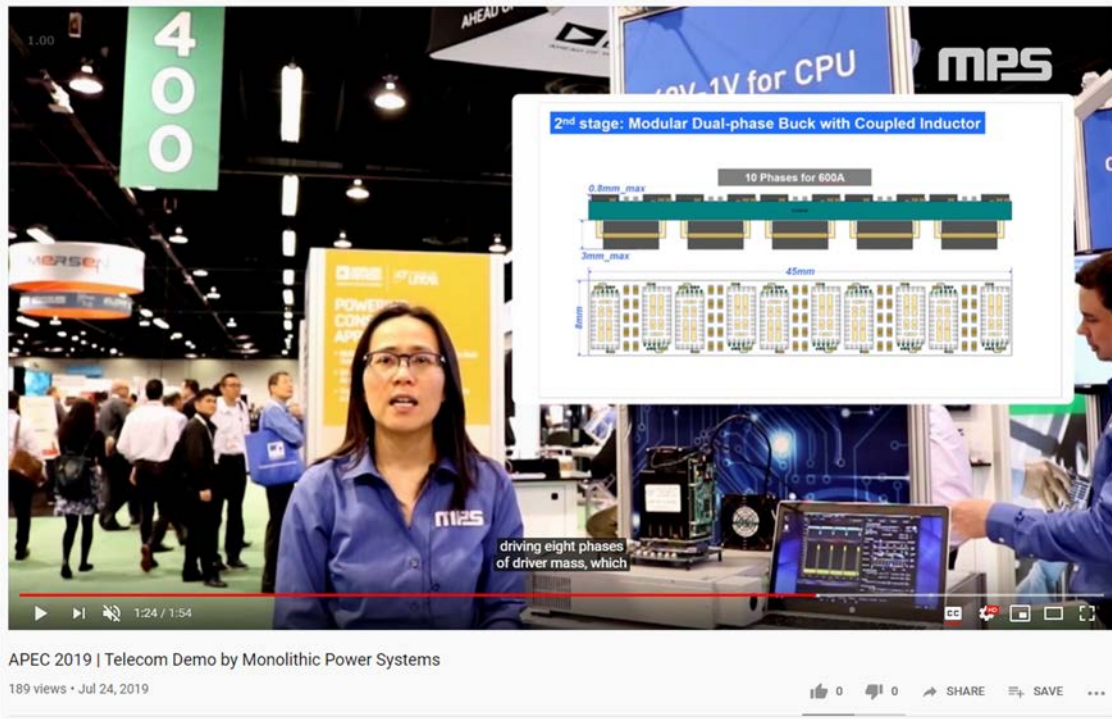

(<https://www.youtube.com/watch?v=w7CmBr1t3Ns>).

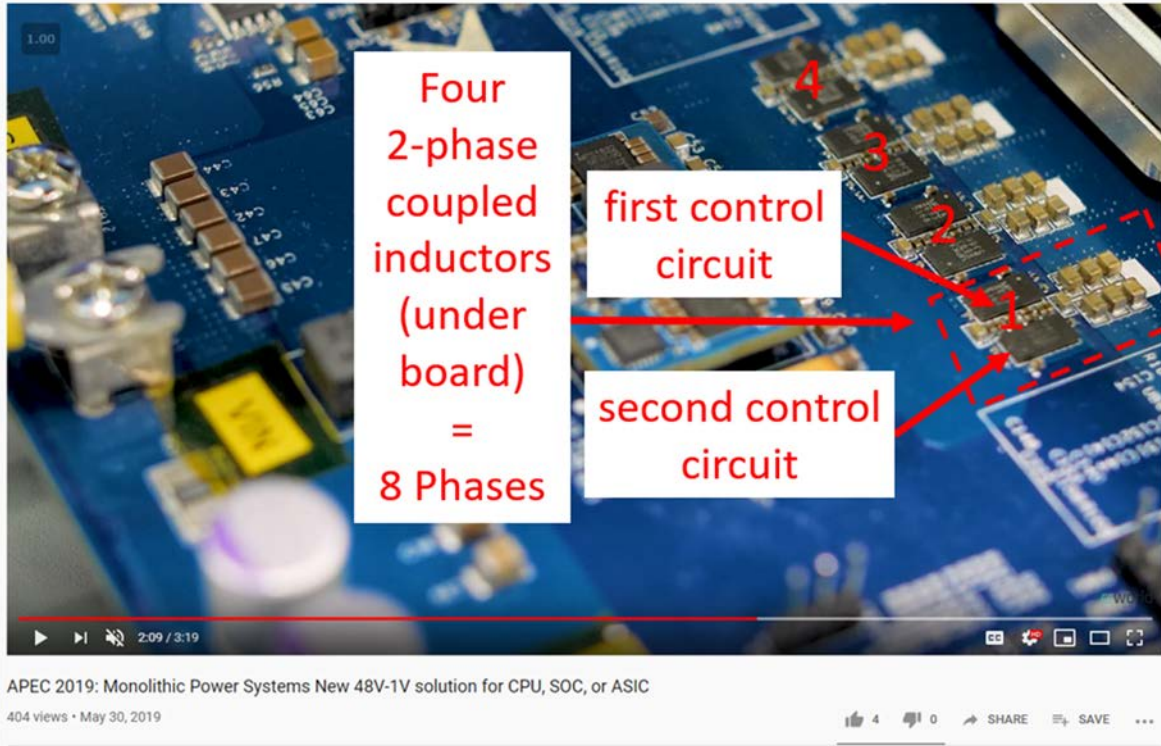

(<https://www.youtube.com/watch?v=WIC2SDWSins> (annotation added)).

51. The Accused Products include a magnetic core including a first and a second magnetic element and N connecting magnetic elements, N being an integer greater than one, the first and second magnetic elements being disposed parallel to each other and separated by a linear separation distance, each connecting magnetic element being coupled to the first and second magnetic elements, the first and second magnetic elements and the N connecting elements cooperatively forming N-1 passageways. For example, the Accused Products include 2-phase coupled inductors, and each coupled inductor includes a magnetic core. Each magnetic core includes a first and second magnetic element and two connecting magnetic elements, and the first and second magnetic elements are disposed parallel to each other and separated by a linear separation distance. Each connecting magnetic element is coupled to the first and second magnetic



elements, and a passageway is cooperatively formed by the first and second magnetic elements and the two connecting magnetic elements.

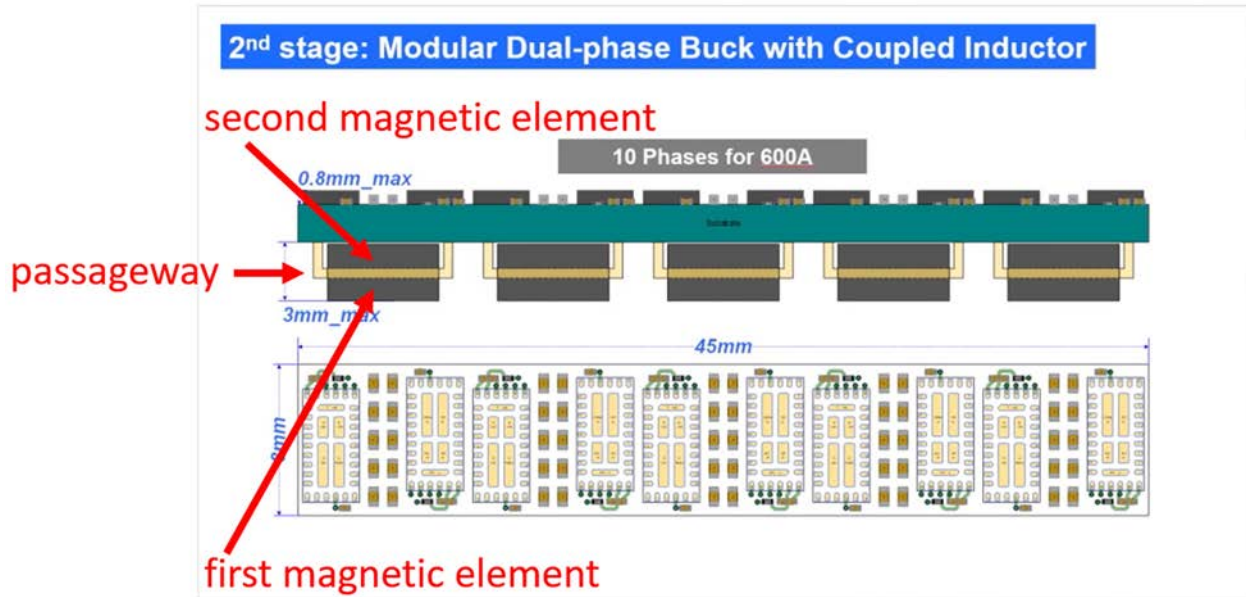

(<https://www.youtube.com/watch?v=w7CmBr1t3Ns> (annotation added)).

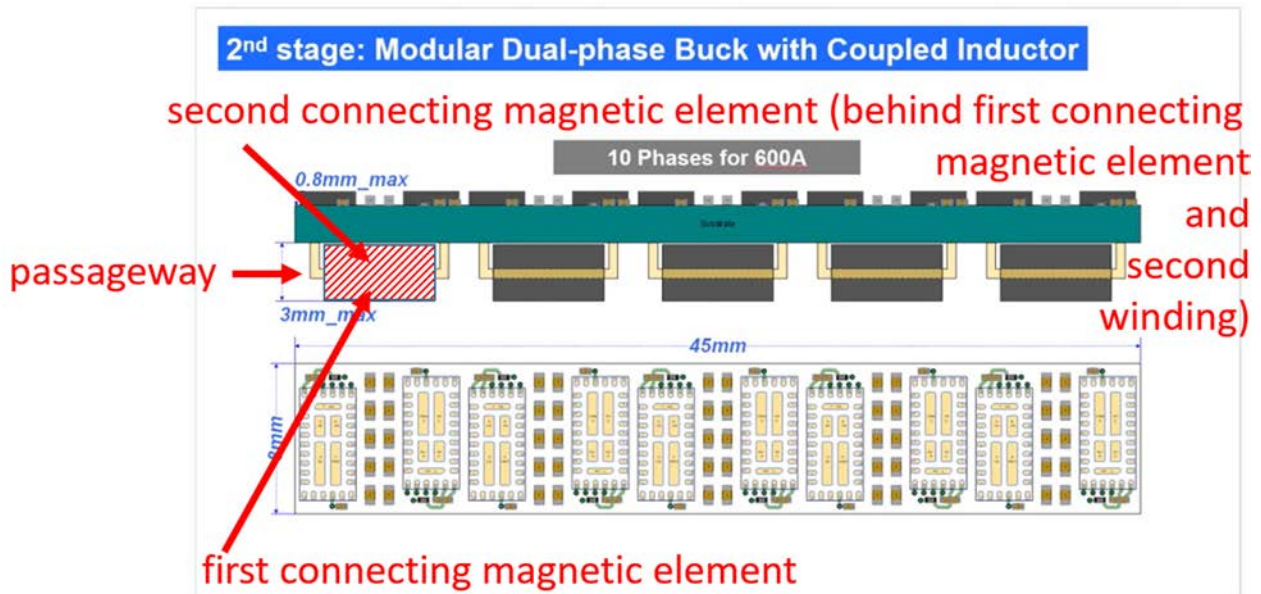

(<https://www.youtube.com/watch?v=w7CmBr1t3Ns> (annotation added)).

52. The Accused Products include N windings, each of the N windings for electrically connecting to a respective phase of the power converter. For example, the Accused Products



include 2-phase coupled inductors, and each 2-phase coupled inductor includes two inductive windings and is connected to two control circuits. The first control circuit electrically connects a first phase of the power converter to the first winding and the second control circuit electrically connects a second phase of the power converter to the second winding.

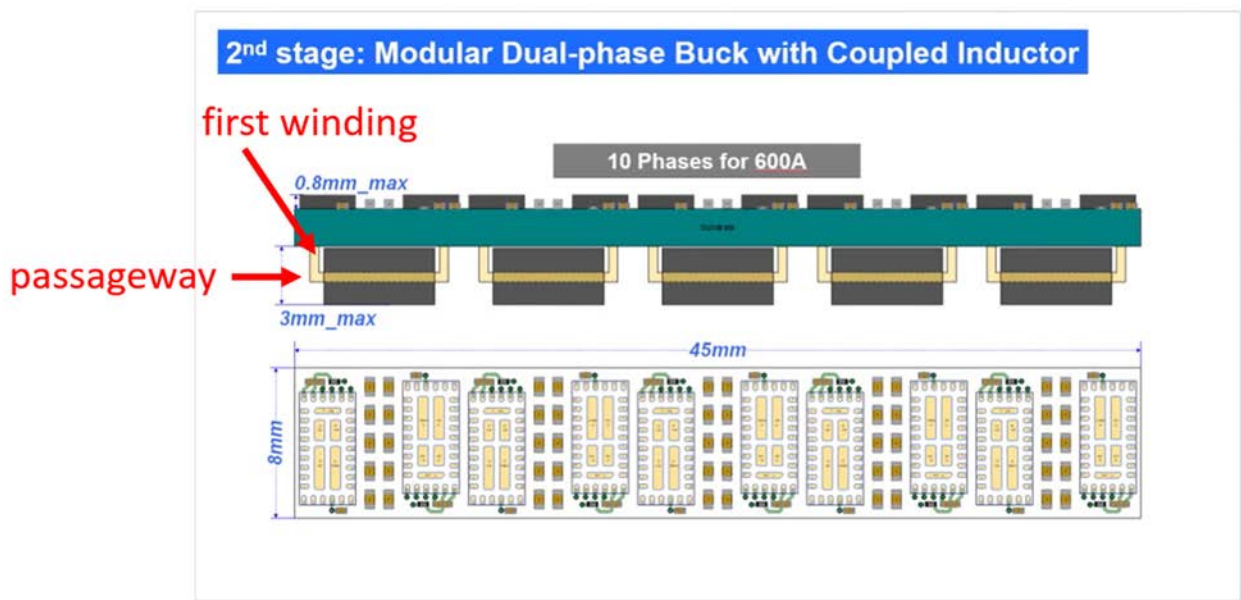

(<https://www.youtube.com/watch?v=w7CmBr1t3Ns> (annotation added)).

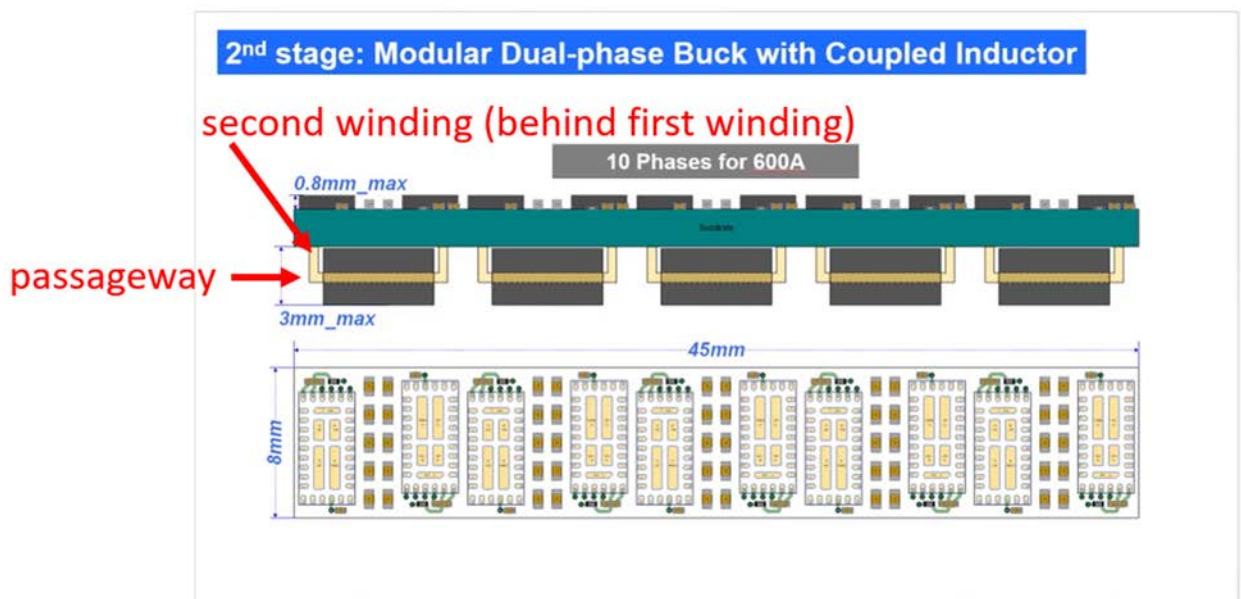

(<https://www.youtube.com/watch?v=w7CmBr1t3Ns> (annotation added)).

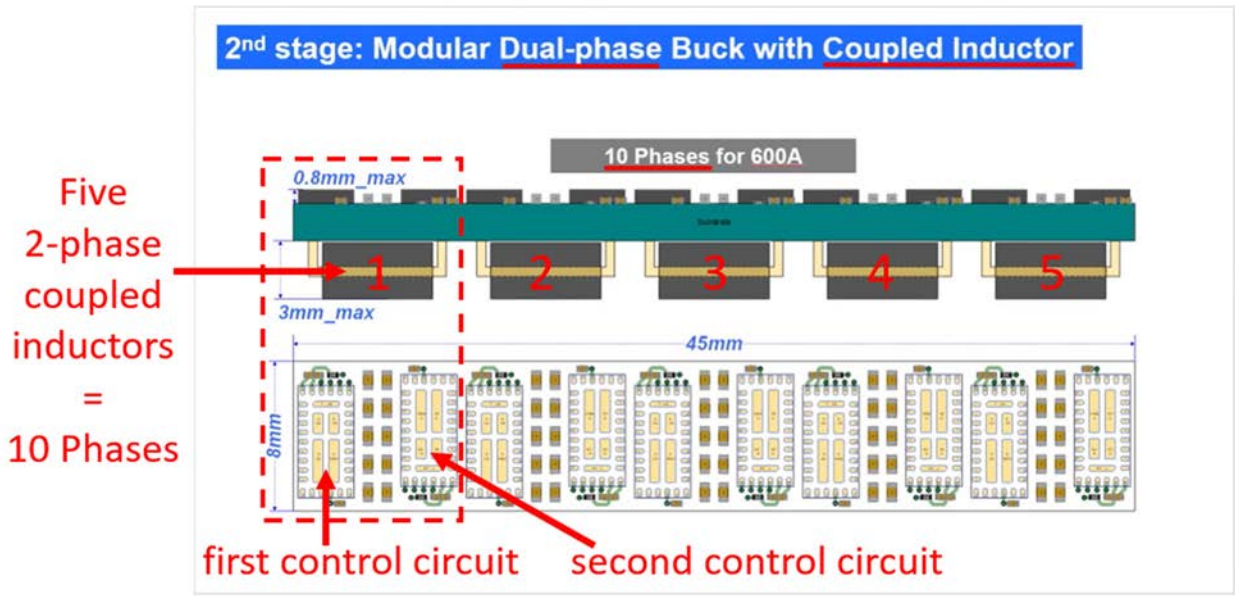

(<https://www.youtube.com/watch?v=w7CmBr1t3Ns> (annotation added)).

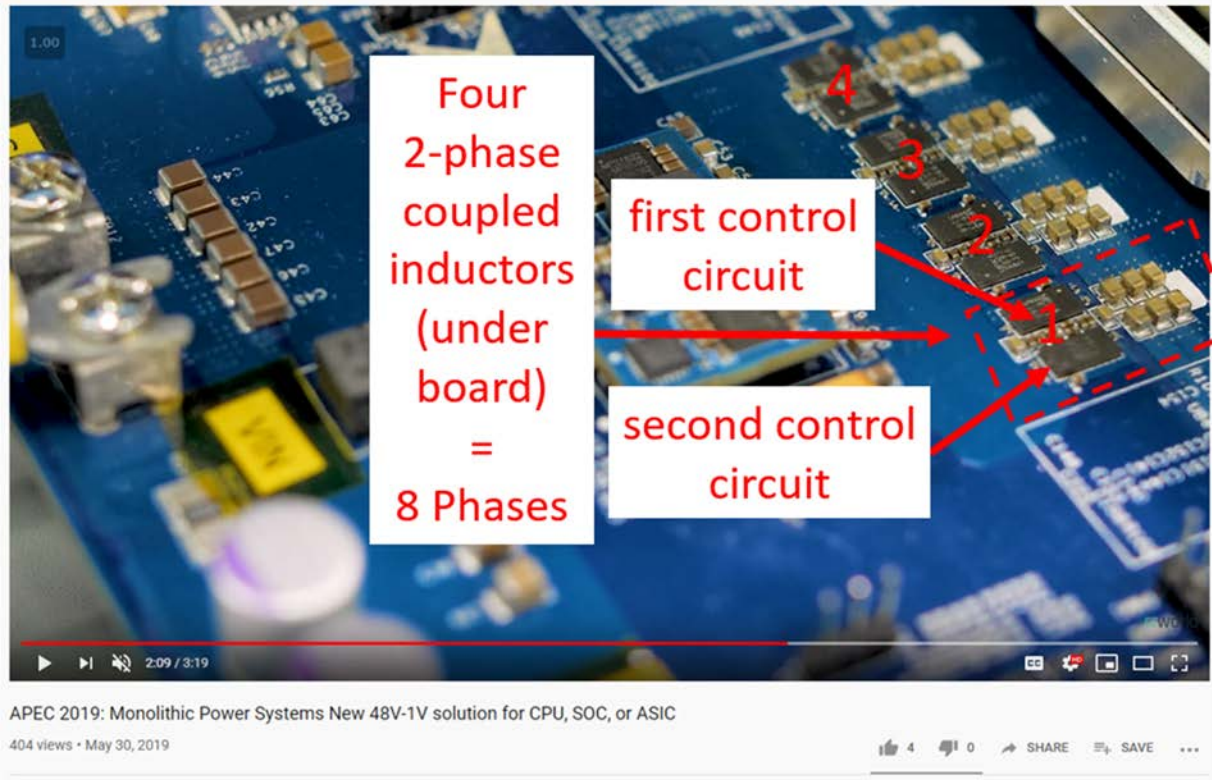

(<https://www.youtube.com/watch?v=WIC2SDWSins> (annotation added)).



53. The Accused Products have each winding being wound about a respective connecting element and at least partially through at least one passageway. For example, each 2-phase coupled inductor in the Accused Products includes two inductive windings, two connecting magnetic elements, and one passageway. The first inductive winding is wound about the first connecting magnetic element and at least partially through the passageway, and the second inductive winding is wound about the second connecting magnetic element and at least partially through the passageway.

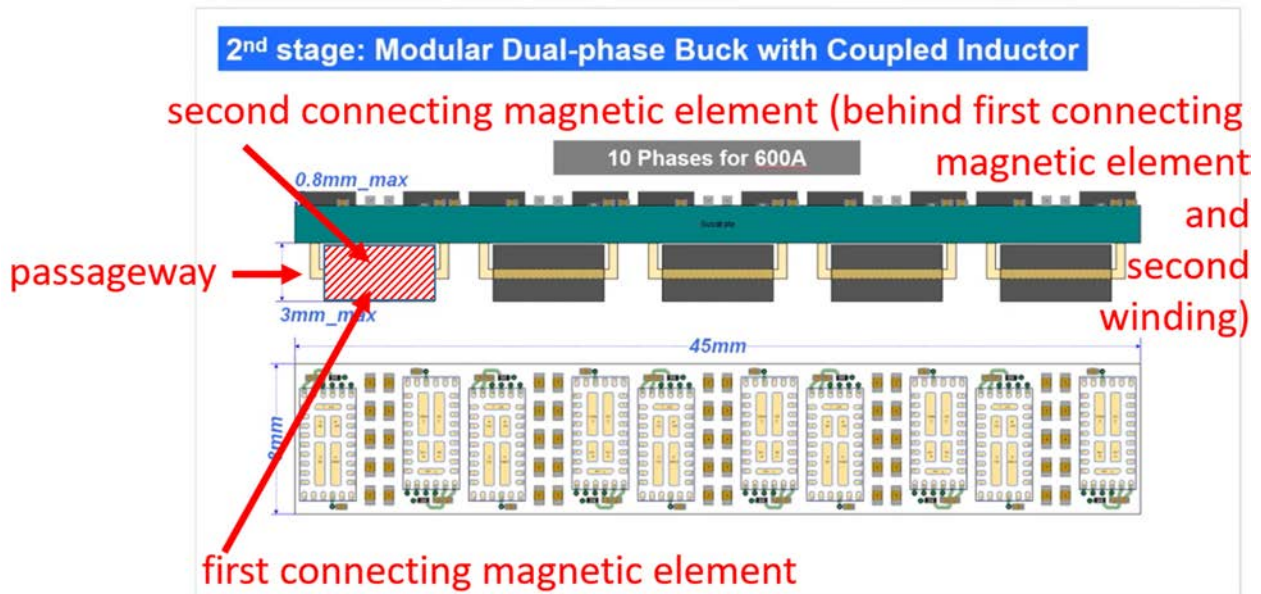

(<https://www.youtube.com/watch?v=w7CmBr1t3Ns> (annotation added)).

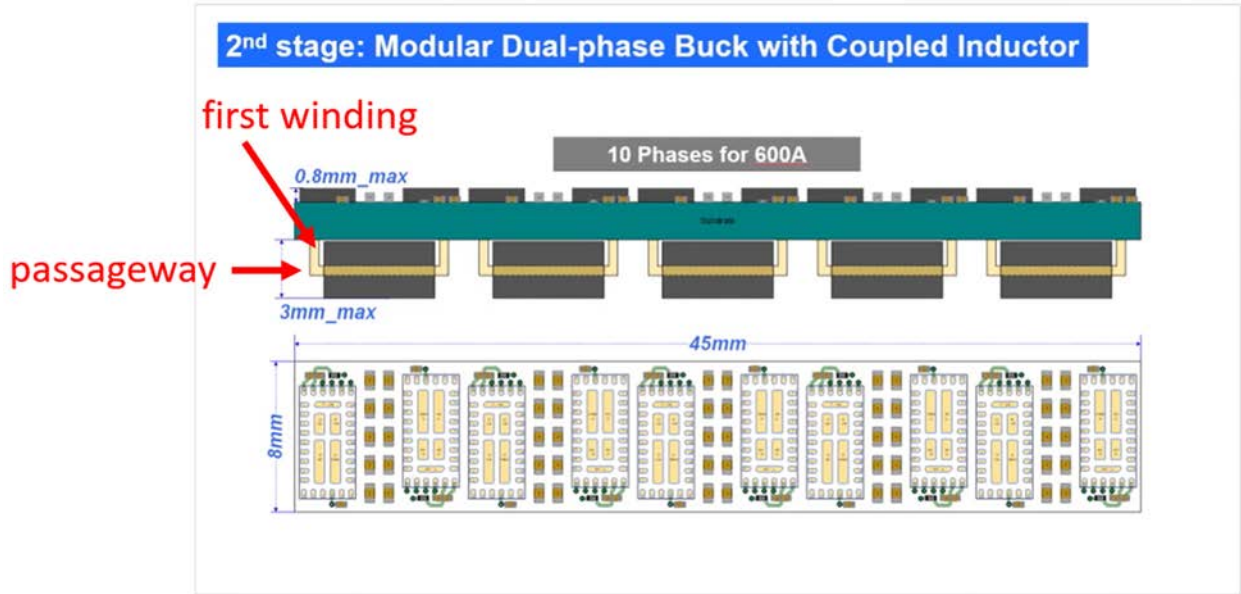

(<https://www.youtube.com/watch?v=w7CmBr1t3Ns> (annotation added)).

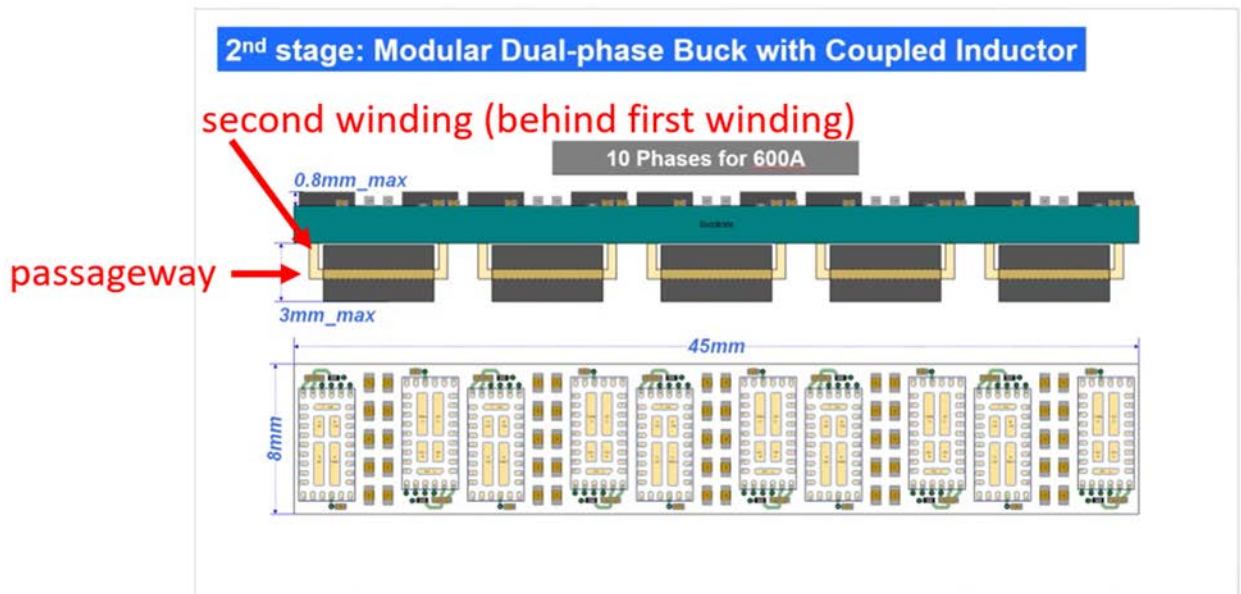

(<https://www.youtube.com/watch?v=w7CmBr1t3Ns> (annotation added)).

54. The Accused Products have each passageway having two of the N windings wound at least partially therethrough. For example, each 2-phase coupled inductor in the Accused Products includes a passageway having the first and second windings wound at least partially therethrough.

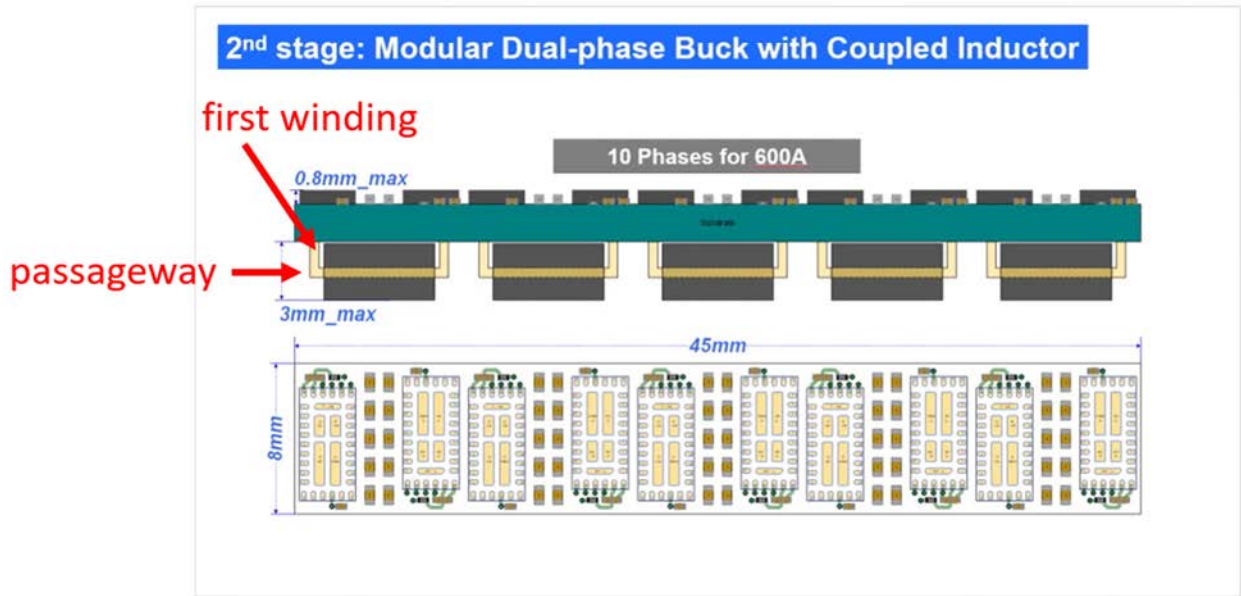

(<https://www.youtube.com/watch?v=w7CmBr1t3Ns> (annotation added)).

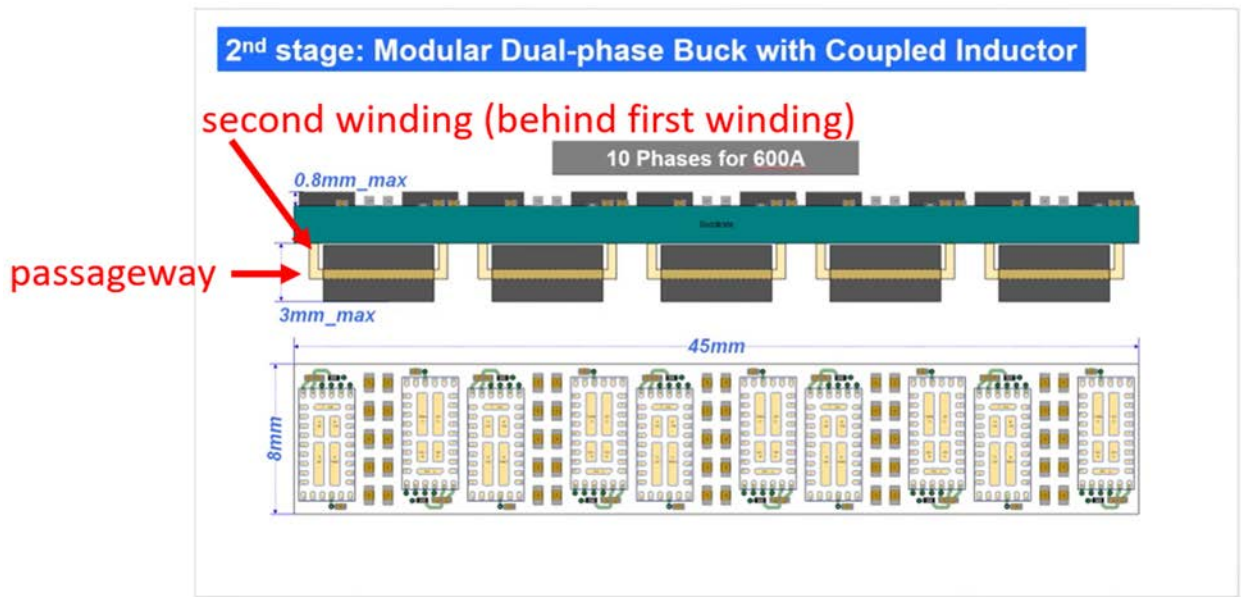

(<https://www.youtube.com/watch?v=w7CmBr1t3Ns> (annotation added)).

55. Claim 20 of the '408 patent recites: The coupled inductor of claim 14, each winding having rectangular cross section.

56. The Accused Products include each winding having rectangular cross section. For example, the layout demonstrated at APEC 2019 indicates that the 2-phase coupled inductors are



surface-mounted components, and the use of surface-mounted coupled inductors indicates that the first and second windings of the coupled inductor have flat pads for soldering to the board. A common manufacturing practice to create flat solderable pads for the windings is to use windings with rectangular cross sections, which allows the flat surface of the winding to be used as a flat soldering pad.

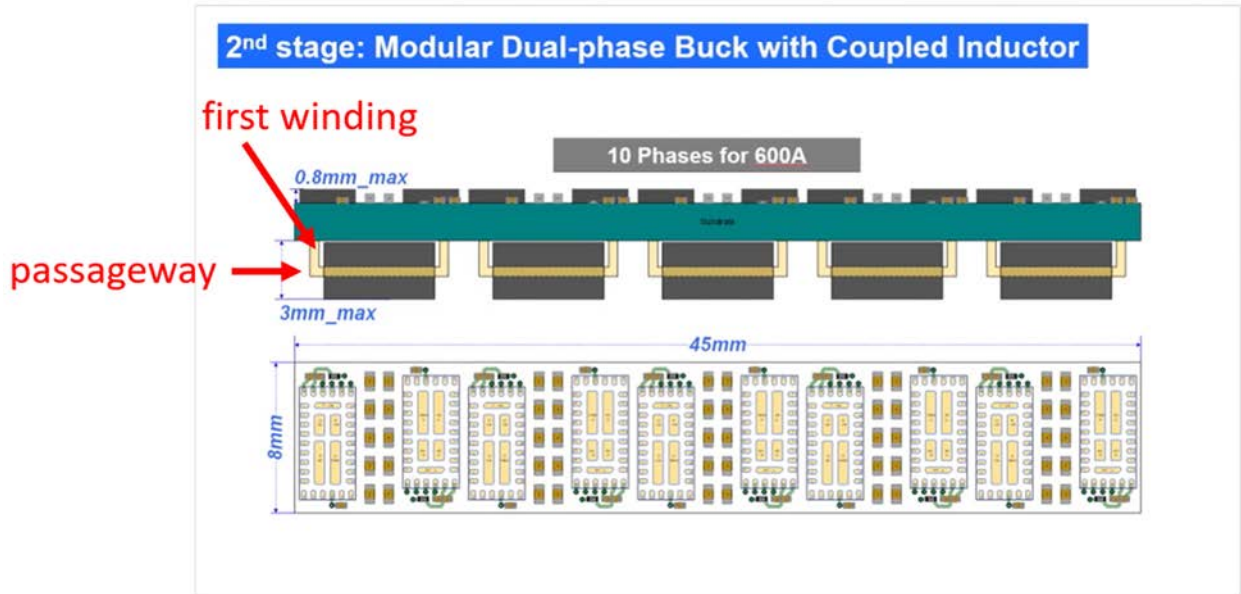

(<https://www.youtube.com/watch?v=w7CmBr1t3Ns> (annotation added)).

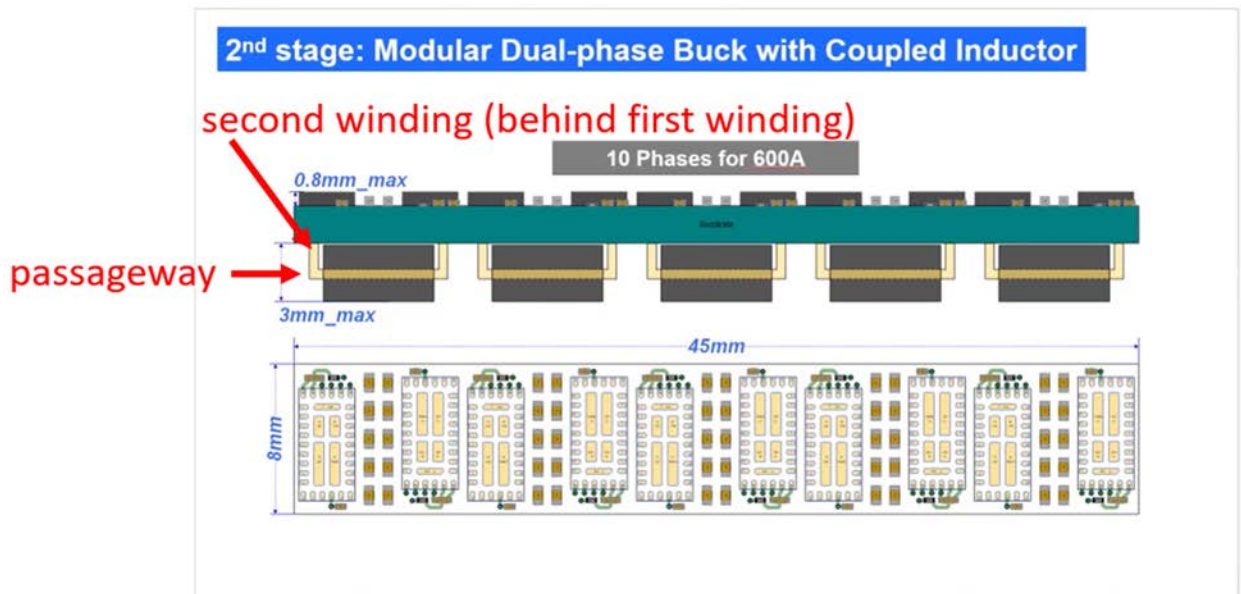



(<https://www.youtube.com/watch?v=w7CmBr1t3Ns> (annotation added)).

57. This description is based on publicly available information and a reasonable investigation of the structure and operation of the Accused Products. Volterra reserves the right to modify this description, including, for example, on the basis of information about the Accused Products that it obtains during discovery.

58. Monolithic's infringement has damaged and continues to damage Volterra in an amount yet to be determined, of at least a reasonable royalty and/or the lost profits that Volterra would have made but for Monolithic's acts of infringement.

59. This is an exceptional case. Volterra is entitled to attorneys' fees and costs under 35 U.S.C. § 285 as a result of the infringement of the '408 patent by Monolithic.

60. Volterra has no adequate remedy at law for Monolithic's infringement. As a direct and proximate result of Monolithic's acts of infringement, Volterra has suffered and continues to suffer damages and irreparable harm. Unless Monolithic's acts of infringement are enjoined by the Court, Volterra will continue to be damaged and irreparably harmed.

COUNT III: INFRINGEMENT OF U.S. PATENT NO. 7,772,955

61. Volterra incorporates by reference and realleges all the foregoing paragraphs of this Complaint as if fully set forth herein.

62. On information and belief, Monolithic has directly infringed, continues to infringe, and/or has induced or contributed to the infringement of at least claims 12–21 and 23–28 of the '955 patent by making, using, selling, offering for sale, and/or importing into the United States, without authority or license, the Accused Products in violation of 35 U.S.C. § 271(a). For example, Monolithic directly infringed the '955 patent when it demonstrated its 48V-1V Power Solution for CPU, SoC or ASIC Controller at APEC 2019.



d. As described above with respect to the '986 and '408 patents, technical publications by Monolithic engineers, including at least one who has submitted a declaration in this case regarding the products at issue, show that Monolithic specifically was familiar with Volterra's coupled inductor patents. This is not surprising because Volterra's coupled inductor patents are widely known in this industry. Multiple Monolithic senior engineers have written technical papers in which they discussed the Volterra patented designs at length.

i. As discussed above with respect to the '986 and '408 patents, Mr. Zhou claimed to "communicate regularly with customers about MPS products and opportunities to work together on products." (D.I. 43 at ¶ 1). Mr. Zhou's declaration also illustrates his familiarity with the controllers and coupled inductors at issue in this case. Mr. Zhou's dissertation analyzed what he called the "scalable multi-phase surface mount coupling inductor structure *proposed by Volterra*." To illustrate what he meant by the structure proposed by Volterra, Mr. Zhou cited the '986 patent. The '955 patent shares an inventor with the '986 patent and devotes multiple paragraphs to the '986 patent in the Background of the Invention section, indicating that the patents are related and would be discussed together. Mr. Zhou's dissertation also cited multiple related papers by the inventors of the '986 patent, including Charles R. Sullivan—an inventor of the '955 patent. The dissertation also cites to several other papers by Mr. Sullivan, evidencing that Mr. Zhou was very familiar with his work. An excerpt from the dissertation along with the citations is shown below:

Based on this understanding, a scalable multi-phase surface mount coupling inductor structure is proposed by [77, 78], as shown in Figure 4.15. For each phase, there is one copper winding around the H-core so that the leg for leakage flux path (center leg in Figure 4.1) is eliminated.



Figure 4.15 A scalable multi-phase surface mount coupling inductor structure proposed by Volterra in [77]

- [55] B. Acker, C. Sullivan and S. Sanders, "Current Controlled Synchronous Rectification," IEEE APEC, 1994, pp. 185-191.
- [76] Jieli Li; Sullivan, C.R.; Schultz, A., "Coupled-inductor design optimization for fast-response low-voltage DC-DC converters," APEC 2002. Seventeenth Annual IEEE, Volume: 2, 10-14 March 2002, Pages: 817 – 823.
- [77] Jieli Li, Schultz, A., Stratakos, A., Sullivan, C.R., "Using Coupled Inductors to Enhance Transient Performance of Multi-Phase Buck Converters," APEC 2004. Seventeenth Annual IEEE, Volume: 2, 10-14 March 2002, Pages: 817 – 823.
- [78] Aaron M. Schultz, Charles R. Sullivan, "Voltage Converter with Coupled Inductive Windings, and Associated Methods," U. S. Patent 6362986 B1, March 26, 2002.
- [98] L. Daniel, C. R. Sullivan and S. R. Senders, "Design of Microfabricated Inductors," Proc. IEEE PESC, 1996, pp. 1447-1455.
- [120] C.J. Mehas, K.D. Coonley and C.R. Sullivan, "Converter and inductor design for fast-response microprocessor power delivery," in Proc. IEEE PESC, 2000, pp. 1621-1626.

- ii. Mr. Dong's Dissertation discussed Volterra's inventions and cited papers written by Mr. Sullivan. Indeed, Mr. Dong recognized that "C. Sullivan developed the **n-phase coupled-inductor buck converter** analysis when the duty cycle D is less than $1/n$." The '955 patent is entitled "Method for making magnetic components with **N-phase coupling**, and related inductor structures" and "relates to construction of a **coupled inductor within a multi-phase DC-to-DC converter**." Mr. Dong also analyzed "C. Sullivan's two-phase coupled-inductor structure" and "C. Sullivan's three-



phase coupled-inductor and its magnetic paths.” Like Mr. Zhou, Mr. Dong’s dissertation cites to several papers by Mr. Sullivan, evidencing that Mr. Zhou was very familiar with his work.

[14] G. J. Mehas, K. D. Coonley and C. R. Sullivan, “Converter and inductor design for fast-response microprocessor power delivery,” Proc. of IEEE PESC, 2001, pp. 1621-1626.

[40] J. Li, A. Stratakos, A. Schultz, C. R. Sullivan, “Using coupled-inductors to enhance transient performance of multi-phase buck converters,” in Proc. IEEE APEC ‘04, Feb. 22-26, 2004, Anaheim, CA, pp. 1289–1293.

[41] Jieli Li, Charles R. Sullivan, Aaron Schultz, “Coupled-inductor design optimization for fast-response low-voltage DC-DC converters”, in Proceedings of APEC 2002 - Applied Power Electronics Conf., pp. 817–823 vol.2.

[42] A. M. Schultz and C. R. Sullivan, “Voltage converter with coupled inductive windings and associated methods”, U.S. Patent 6,362,986, Mar. 26, 2002, Volterra Semiconductor Corp.

[53] Jieli Li, T. Abdallah, and C.R. Sullivan, “Improved calculation of core loss with non-sinusoidal waveforms”, in Proc. IEEE IAS 2001, pp.2203-2210.

[54] A. Hoke and C. R. Sullivan, "An Improved two-dimensional numerical modeling method for E-core transformers," in Proc. IEEE APEC '02, Mar. 10-14, 2002, Dallas, TX, pp. 151 - 157.

e. Finally, Volterra realleges that Monolithic’s knowledge and intent is further demonstrated by post-suit activity. By at least December 9, 2019, Volterra disclosed, at least by filing its Complaint, the existence of the ’955 patent and identified at least some of Monolithic’s and others’ activities that infringe the ’955 patent. Thus, based on this disclosure, Monolithic had knowledge of the ’955 patent and that its activities infringe the ’955 patent since at least December 9, 2019. Based on Volterra’s disclosures, Monolithic has also known or should have known since at least December 9, 2019 that its customers, distributors, suppliers, and other purchasers of the Accused Products are infringing the ’955 patent at least because Monolithic has known that it is infringing the ’955 patent.



64. Monolithic also actively, knowingly, and intentionally induces infringement of one or more claims of the '955 patent under 35 U.S.C. § 271(b) by actively encouraging others to import into the United States, and/or make, use, sell, and/or offer to sell in the United States, Accused Products or products containing the infringing semiconductor components of the Accused Products.

- a. For example, Monolithic actively promotes the sale, use, and importation of the Accused Products in marketing materials and videos made available on its YouTube channel (e.g., www.youtube.com/channel/UCqOx8jWRKEq4TpfCjCz0Isw) as well as at trade shows (e.g., APEC 2019) and through its sales and distribution channels that encourage infringing uses, sales, offers to sell, and importation of the Accused Products.
- b. As another example, Monolithic designs controllers that operate in a Couple Inductor mode, including the MP2888A controller and the MP2965 controller. As described above with respect to the '986 and '408 patents, Monolithic makes the datasheets for each of these controllers publicly available, and these datasheets describe Couple Inductor mode and instruct customers how to program the controllers to operate in Couple Inductor mode.
- c. By way of further example, Monolithic provides reference designs, evaluation boards, and evaluation tools to its customers that encourage infringing uses, sales, offers to sell, and importation of the Accused Products. As described above, since 2018, Monolithic has sold the MP2888A Digital, Multi-Phase PWM Controller with PMBus and PWM-VID, which “supports couple-inductor mode to reduce the

[REDACTED]

overshoot during load releasing.” Monolithic supplies Evaluation Tools and Design Resources for this controller on its website. (<https://www.monolithicpower.com/en/mp2888a.html>). On information and belief, Monolithic provides similar Evaluation Tools and Design Resources for all of its controllers that support Couple Inductor mode. (See <https://www.monolithicpower.com/en/mp2965.html>).

- d. As another example, Monolithic coordinates with suppliers of coupled inductors to manufacture the coupled inductors included in the Accused Products. As described above, Monolithic reached out to [REDACTED] to request that [REDACTED] develop a coupled inductor for Monolithic’s use. On information and belief, Monolithic has coordinated with other suppliers of coupled inductors, including the supplier that provided the coupled inductors in the 48V-1V Power Solution for CPU, SoC or ASIC Controller that Monolithic demonstrated at APEC 2019.
- e. As another example, on information and belief, Monolithic representatives travel to customer sites for sales and support activity that includes working with customers and suppliers to facilitate these customers’ infringing testing, marketing, importation, and sales activity.
- f. On information and belief, Monolithic supplies its customers, distributors, and suppliers with Accused Products so that they may be used, sold, offered for sale, and/or imported into the United States by those customers and suppliers.

65. Monolithic further contributes to the infringement of one or more claims of the ’955 patent under 35 U.S.C. § 271(c) by offering to sell, selling, and/or importing into the United States a component of the Accused Products, or a material or apparatus for use in practicing a process



claimed in the '955 patent, that constitutes a material part of the inventions, knowing the same to be especially made or especially adapted for use in an infringement of the '955 patent, and is not a staple article or commodity of commerce suitable for substantial noninfringing use.

- a. For example, on information and belief, Monolithic contributes to its customers' infringement of the '955 patent when it manufactures, designs, or assists in the design of a material part of the Accused Products. As discussed above, Monolithic manufactures the MP2888A and MP2965 controllers that are designed to operate in Couple Inductor mode. Monolithic makes the datasheets for each of these controllers publicly available, and these datasheets describe Couple Inductor mode and instruct customers how to program the controllers to operate in Couple Inductor mode.
- b. By way of further example, as discussed above, Monolithic provides reference designs, evaluation boards, and evaluation tools to its customers that comprise a component of an apparatus claimed in the '955 patent.

66. The Accused Products meet all the limitations of at least claims 12–21 and 23–28 of the '955 patent.

67. Claim 12 of the '955 patent recites: A coupled inductor, comprising: a magnetic core having a bottom side, a first side, and a second side opposite of the first side, the magnetic core forming a passageway extending from the first side to the second side, the passageway having depth and height defining a cross-sectional area of the passageway, the magnetic core including an outer leg extending from the first side to the second side and partially defining the passageway; and a first and a second winding having a same number of turns, the first and second windings wound at least partially around the outer leg and through the passageway, the first and second



windings separated by a linear separation distance throughout the passageway, the separation distance being along an axis perpendicular to an axis of the height of the passageway and perpendicular to an axis of the depth of the passageway, the separation distance being greater than the height of the passageway, the cross-sectional area of the passageway between the windings being at least 50% free of magnetic material, each winding having a respective first end and a respective second end extending to the bottom side of the magnetic core for soldering to a printed circuit board.

68. The Accused Products include a coupled inductor. For example, the Accused Products include multiple 2-phase coupled inductors. Monolithic’s demonstration at APEC 2019 included a layout of a 10-phase power converter that showed five 2-phase coupled inductors.

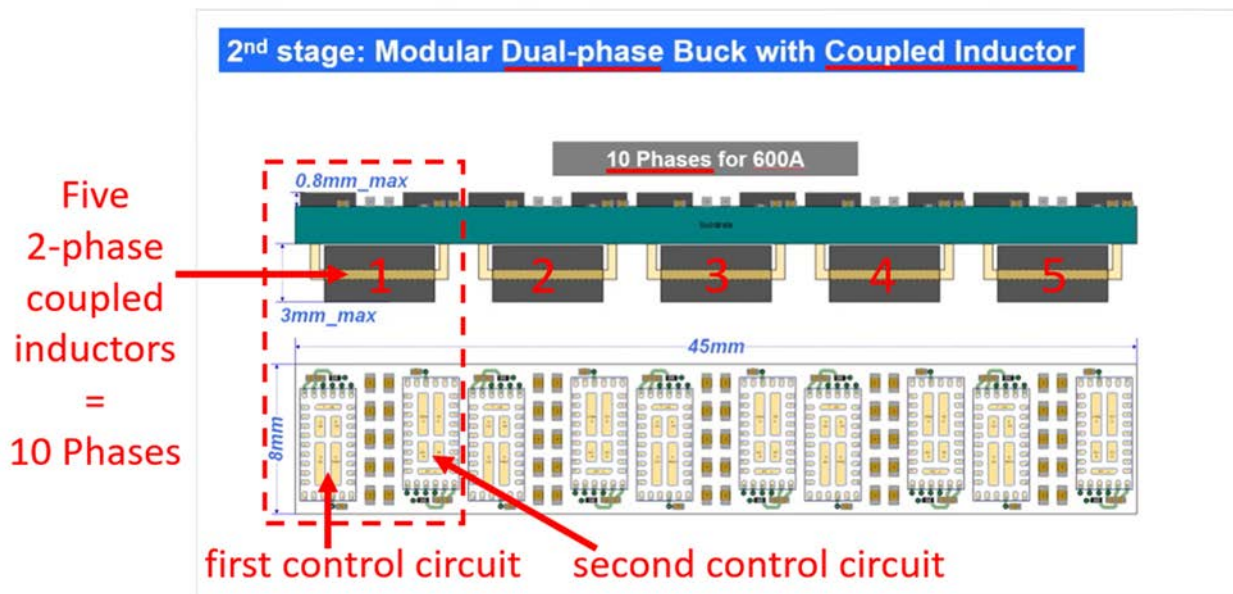

(<https://www.youtube.com/watch?v=w7CmBr1t3Ns> (annotation added)).

69. The Accused Products include a magnetic core having a bottom side, a first side, and a second side opposite of the first side, the magnetic core forming a passageway extending from the first side to the second side, the passageway having depth and height defining a cross-sectional area of the passageway, the magnetic core including an outer leg extending from the first



side to the second side and partially defining the passageway. For example, the Accused Products include 2-phase coupled inductors, and each coupled inductor includes a magnetic core. The layout demonstrated at APEC 2019 indicates that each magnetic core has a bottom side, a first side, and second side opposite the first side, and each magnetic core forms a passageway extending from the first side to the second side. The passageway has depth and height defining a cross-sectional area of the passageway, and the magnetic core includes an outer leg extending from the first side to the second side and partially defining the passageway.

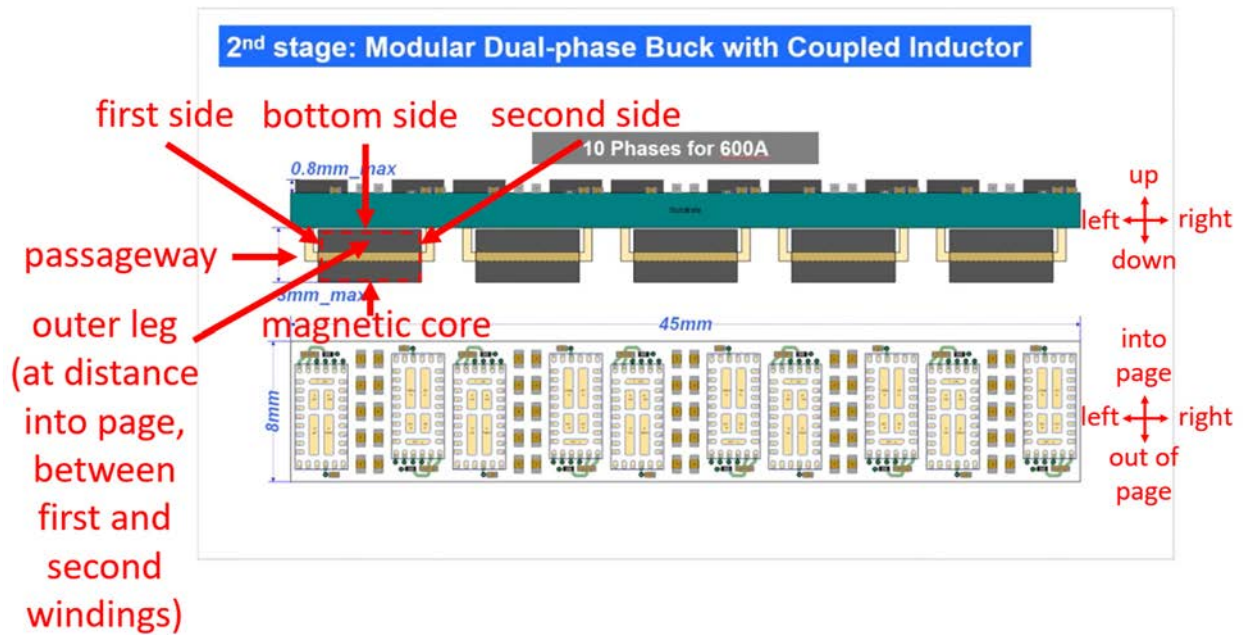

(<https://www.youtube.com/watch?v=w7CmBr1t3Ns> (annotation added)).

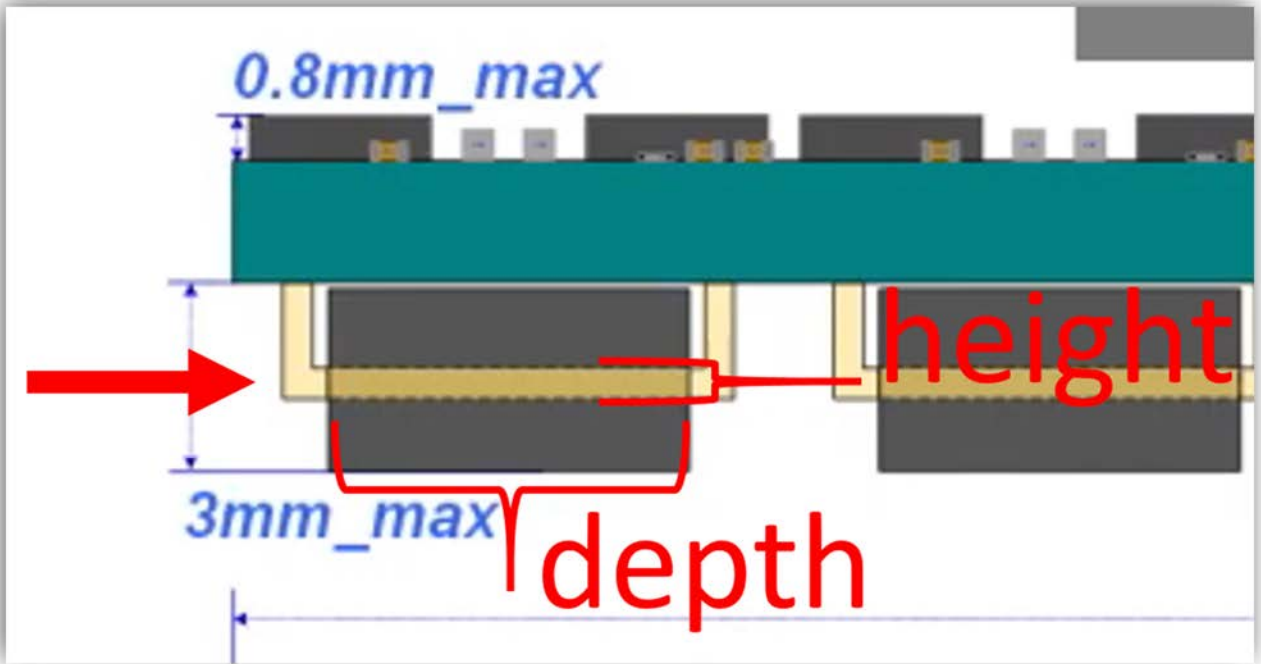
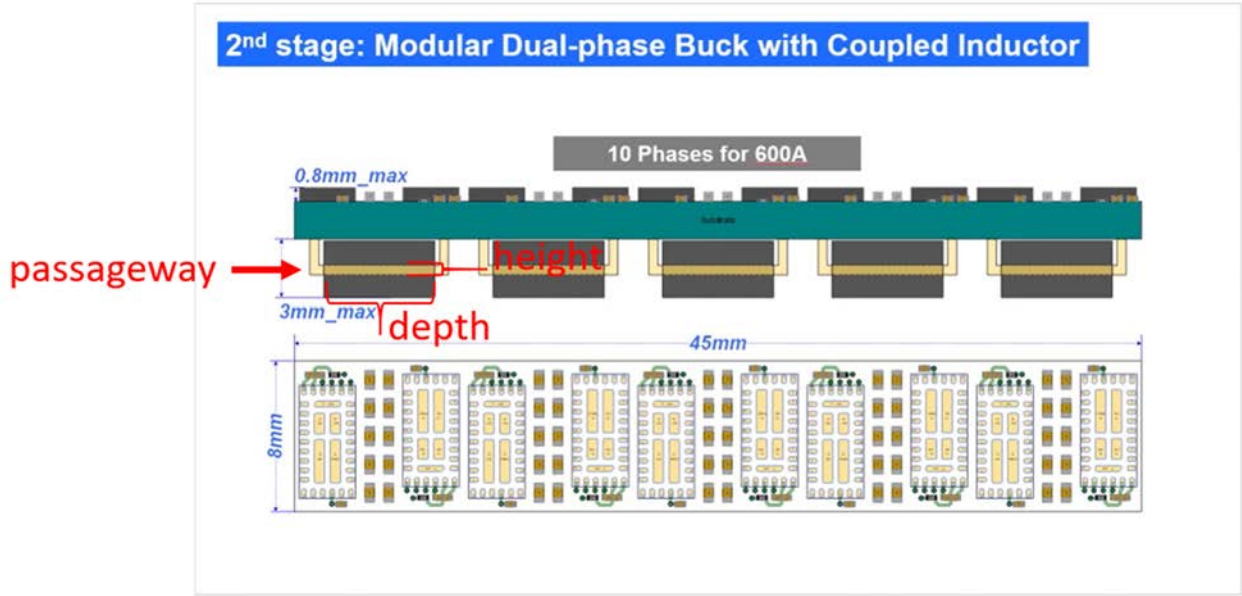

(<https://www.youtube.com/watch?v=w7CmBr1t3Ns> (annotation added)).

70. The Accused Products include a first and a second winding having a same number of turns, the first and second windings wound at least partially around the outer leg and through the passageway, the first and second windings separated by a linear separation distance throughout



the passageway, the separation distance being along an axis perpendicular to an axis of the height of the passageway and perpendicular to an axis of the depth of the passageway, the separation distance being greater than the height of the passageway, the cross-sectional area of the passageway between the windings being at least 50% free of magnetic material, each winding having a respective first end and a respective second end extending to the bottom side of the magnetic core for soldering to a printed circuit board. For example, each 2-phase coupled inductor in the Accused Products includes two inductive windings having a single turn. The first and second inductive windings of each 2-phase coupled inductor are wound at least partially around the outer leg and through the passageway. The first and second windings are separated by a linear separation distance throughout the passageway, and the separation distance is along an axis perpendicular to an axis of the height of the passageway and perpendicular to an axis of the depth of the passageway. The separation distance is greater than the height of the passageway, and the cross-sectional area of the passageway between the windings is at least 50% free of magnetic material. For example, the layout demonstrated at APEC 2019 indicates that the first winding (shown in front) is separated from the second winding by a linear separation distance (into the page) perpendicular to an axis of the height of the passageway (up and down) and perpendicular to an axis of the depth of the passageway (left and right). The layout demonstrated at APEC 2019 indicates the use of coupled inductors to convert an intermediate input voltage to an output voltage of 1 volt, and the use of coupled inductors in the demonstrated power converter indicates that the cross-sectional area of the passageway between the windings is at least 50% free of magnetic material. The layout further indicates that the separation distance is greater than the height of the passageway. For example, the layout describes outputting 600A of current, and the ability to achieve this high current from the design demonstrated in the layout indicates that the separation distance is greater than the



height of the passageway shown. The layout also shows that each winding has a respective first end and a respective second end extending to the bottom side of the magnetic core for soldering to a printed circuit board.

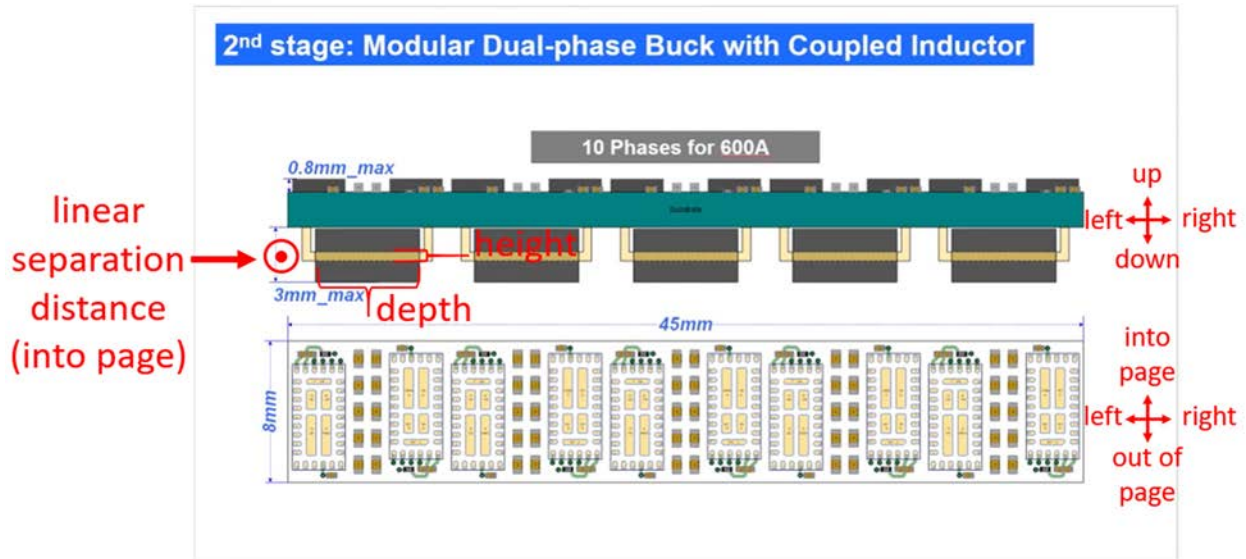

(<https://www.youtube.com/watch?v=w7CmBr1t3Ns> (annotation added)).

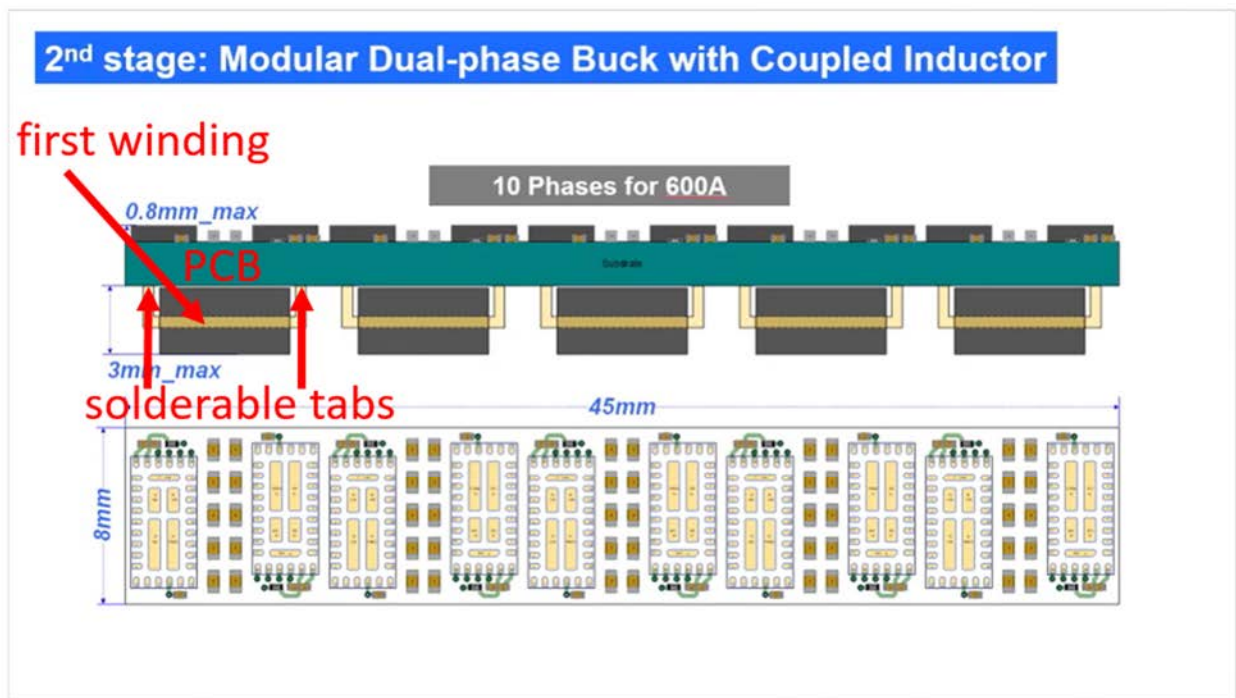

(<https://www.youtube.com/watch?v=w7CmBr1t3Ns> (annotation added)).

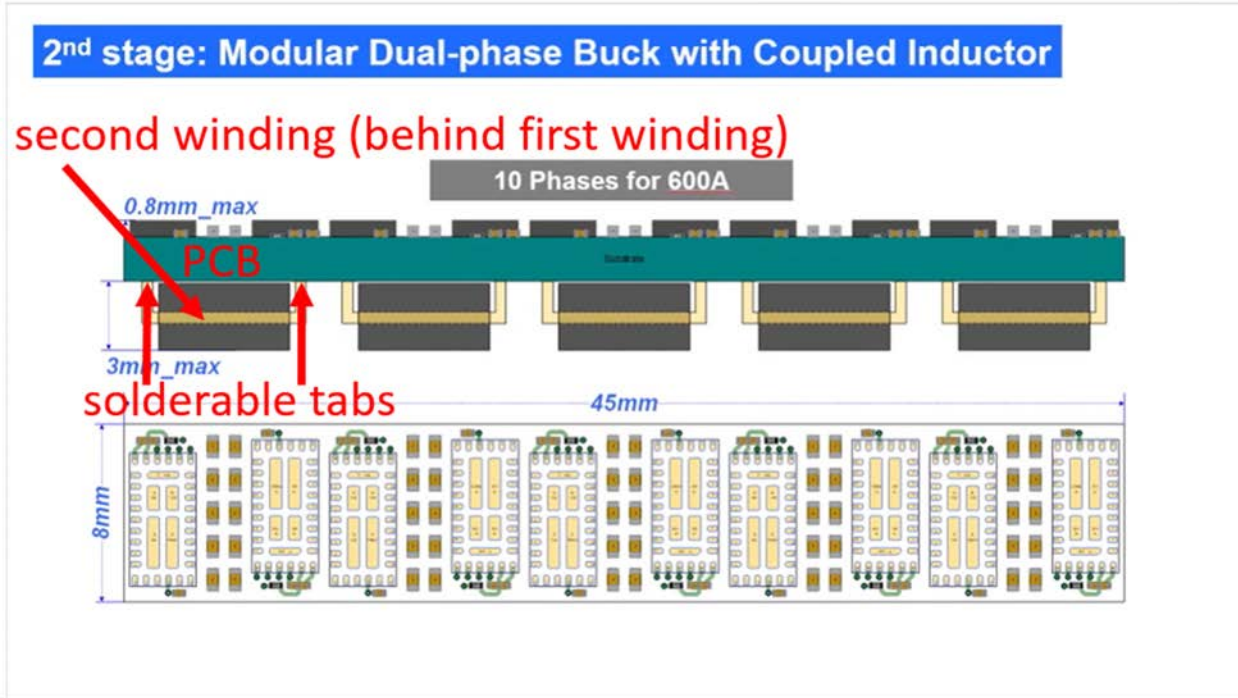

(<https://www.youtube.com/watch?v=w7CmBr1t3Ns> (annotation added)).

71. Claim 13 of the '955 patent recites: Coupled inductor of claim 12, the magnetic core having a rectangular shape, and the first and second sides being orthogonal to the bottom side.

72. The Accused Products include a magnetic core having a rectangular shape, and the first and second sides being orthogonal to the bottom side. For example, the layout demonstrated at APEC 2019 indicates that each magnetic core has a rectangular shape, and the first and second sides are orthogonal to the bottom side.

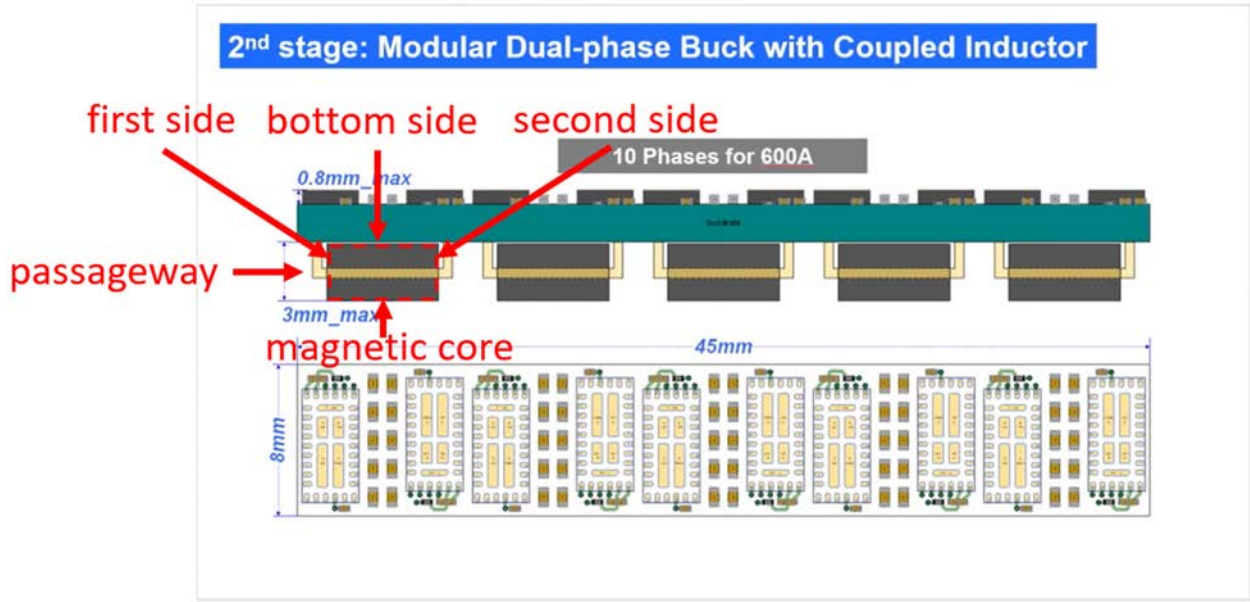

(<https://www.youtube.com/watch?v=w7CmBr1t3Ns> (annotation added)).

73. Claim 14 of the '955 patent recites: Coupled inductor of claim 12, the magnetic core forming a single passageway.

74. The Accused Products include a magnetic core forming a single passageway. For example, the layout demonstrated at APEC 2019 indicates that the first winding (shown in front) of each 2-phase coupled inductor is separated from the second winding of each 2-phase coupled inductor by a linear separation distance (into the page). If this linear separation distance was filled with magnetic material such that more than a single passageway existed in the magnetic core, the first winding and the second winding would be unable to couple and the device demonstrated by MPS would not be a 2-phase coupled inductor. Therefore, the magnetic core in each coupled inductor forms a single passageway.

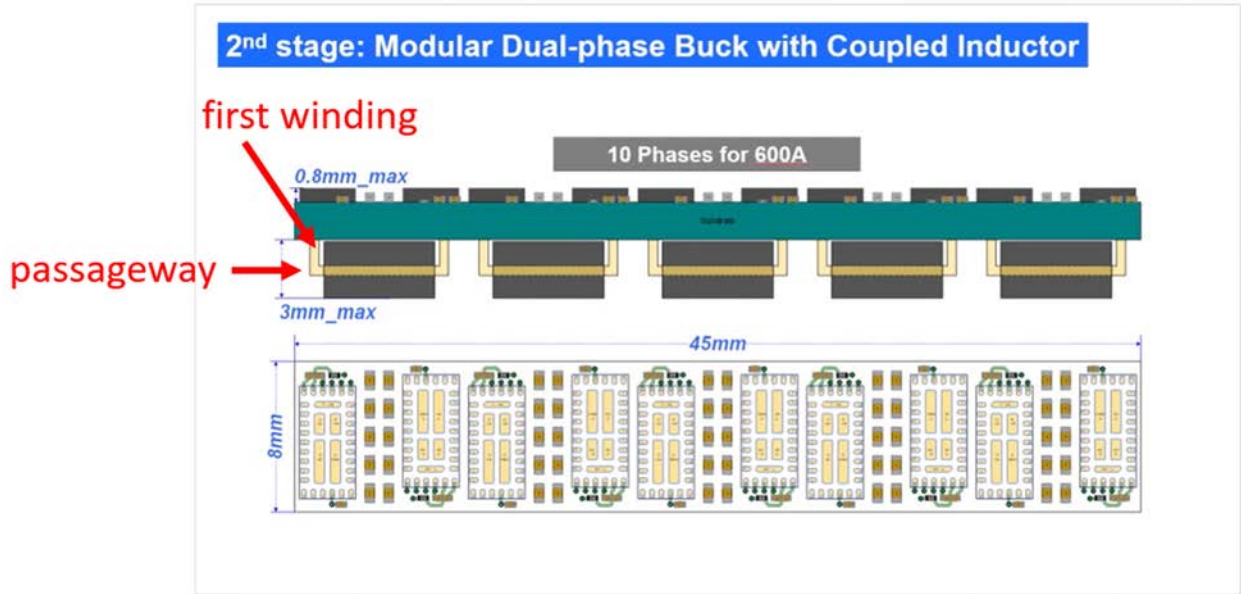

(<https://www.youtube.com/watch?v=w7CmBr1t3Ns> (annotation added)).

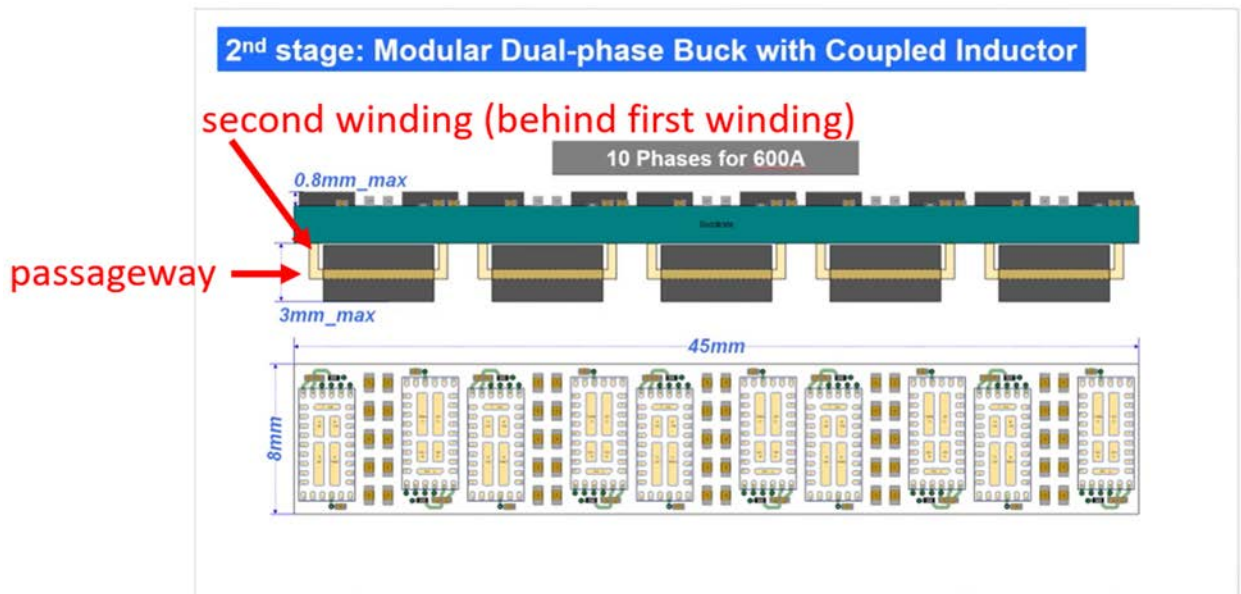

(<https://www.youtube.com/watch?v=w7CmBr1t3Ns> (annotation added)).

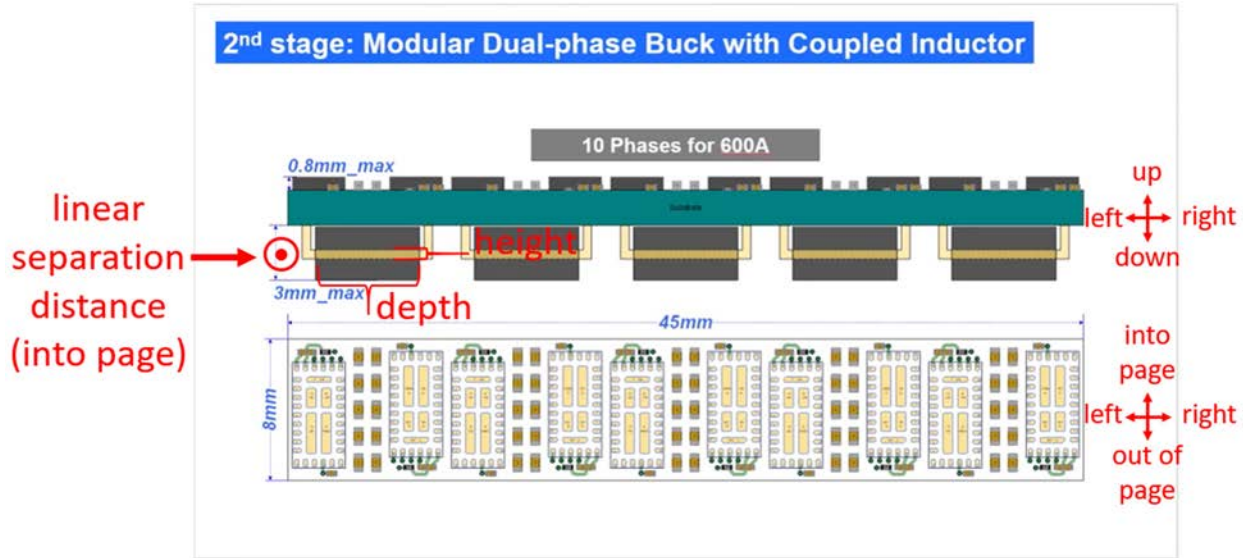

(<https://www.youtube.com/watch?v=w7CmBr1t3Ns> (annotation added)).

75. Claim 15 of the '955 patent recites: Coupled inductor of claim 12, the passageway depth being greater than the passageway height.

76. The Accused Products include a passageway depth being greater than the passageway height. For example, the layout demonstrated at APEC 2019 indicates that the passageway depth is greater than the passageway height.

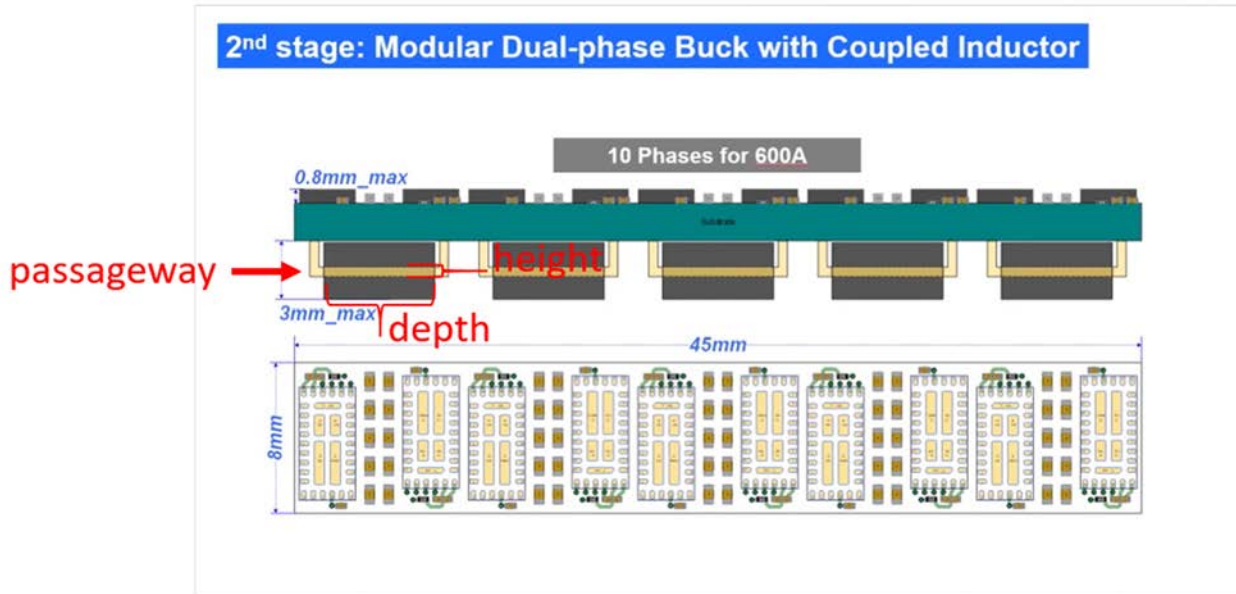

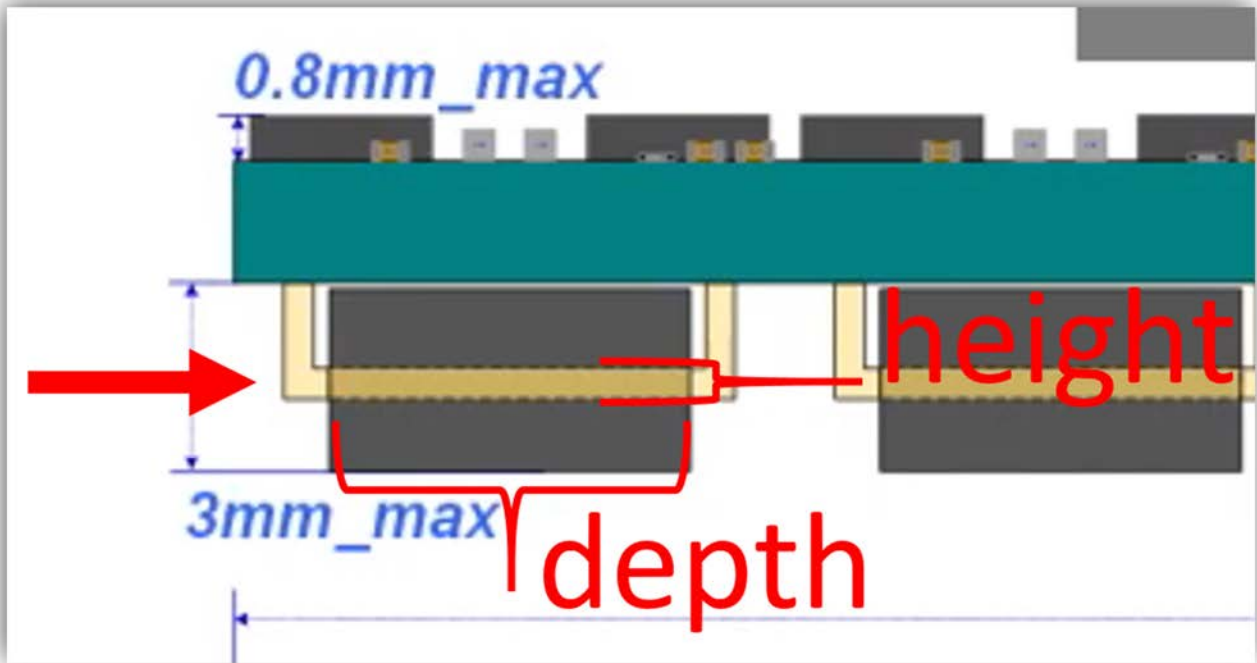

(<https://www.youtube.com/watch?v=w7CmBr1t3Ns> (annotation added)).

77. Claim 16 of the '955 patent recites: A two phase DC-to-DC converter, comprising: a two phase coupled inductor, including: a magnetic core forming a passageway, the passageway having depth and height defining a cross-sectional area of the passageway, and a first and a second winding having a same number of turns wound at least partially around a common leg of the magnetic core and through the passageway, the first and second windings separated by a linear separation distance throughout the passageway the separation distance being along an axis perpendicular to an axis of the height of the passageway and perpendicular to an axis of the depth of the passageway, each winding having a respective first end and a respective second end, the second ends of the first and second windings being electrically connected to a common load, the cross-sectional area of the passageway between the windings being at least 50% free of magnetic material; a first switch electrically connected between a power source and the first end of the first winding; and a second switch electrically connected between the power source and the first end of



the second winding; wherein the first and second switches independently and sequentially switch the first end of their respective winding to an input signal of the power source to regulate an output signal at the load.

78. The Accused Products are two phase DC-to-DC converters. For example, at APEC 2019, Monolithic demonstrated a power converter that converts a 48 volt DC input voltage to a 1 volt DC output voltage.



(<https://www.youtube.com/watch?v=w7CmBr1t3Ns>).

79. The Accused Products include a two phase coupled inductor. For example, the Accused Products include multiple two phase coupled inductors. Monolithic's demonstration at APEC 2019 included a layout of a 10-phase power converter that showed five 2-phase coupled inductors.

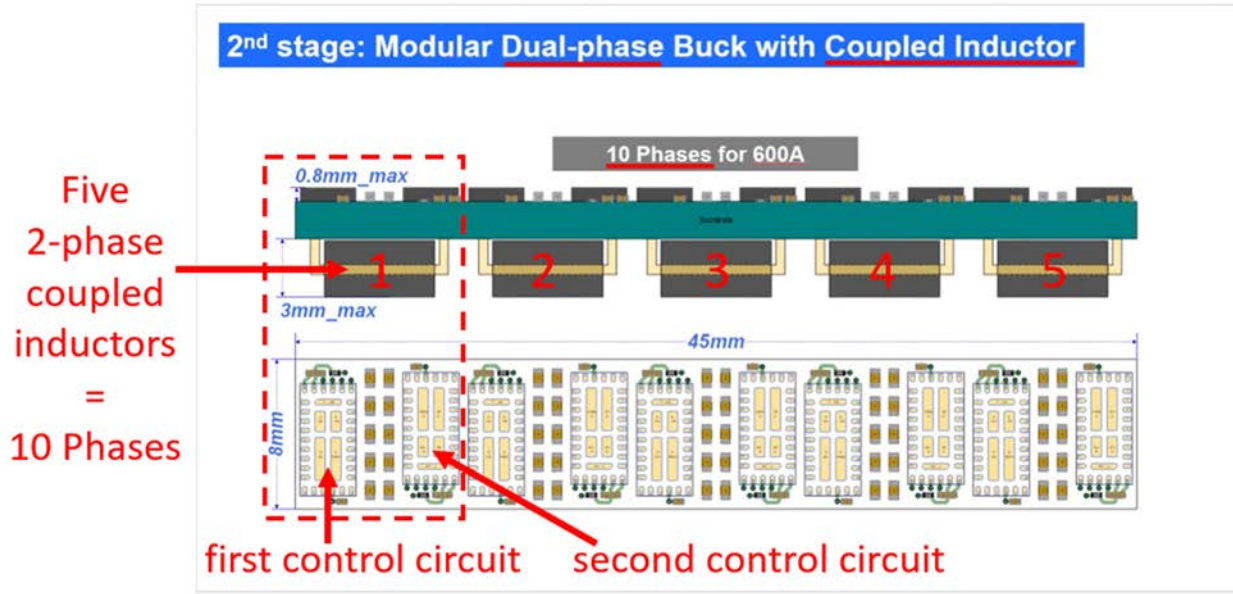

(<https://www.youtube.com/watch?v=w7CmBr1t3Ns> (annotation added)).

80. The two phase coupled inductors of the Accused Products include a magnetic core forming a passageway, the passageway having depth and height defining a cross-sectional area of the passageway. For example, the Accused Products include two phase coupled inductors, and each coupled inductor includes a magnetic core. The layout demonstrated at APEC 2019 indicates that each magnetic core has a passageway having depth and height defining a cross-sectional area of the passageway.

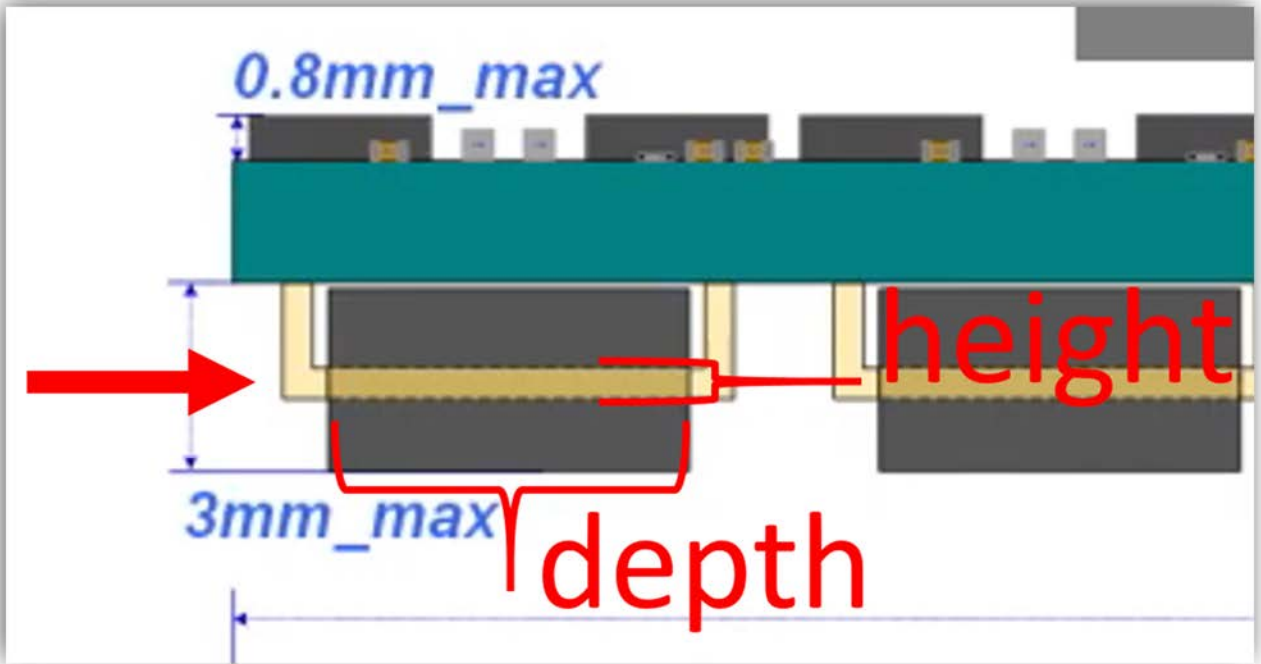
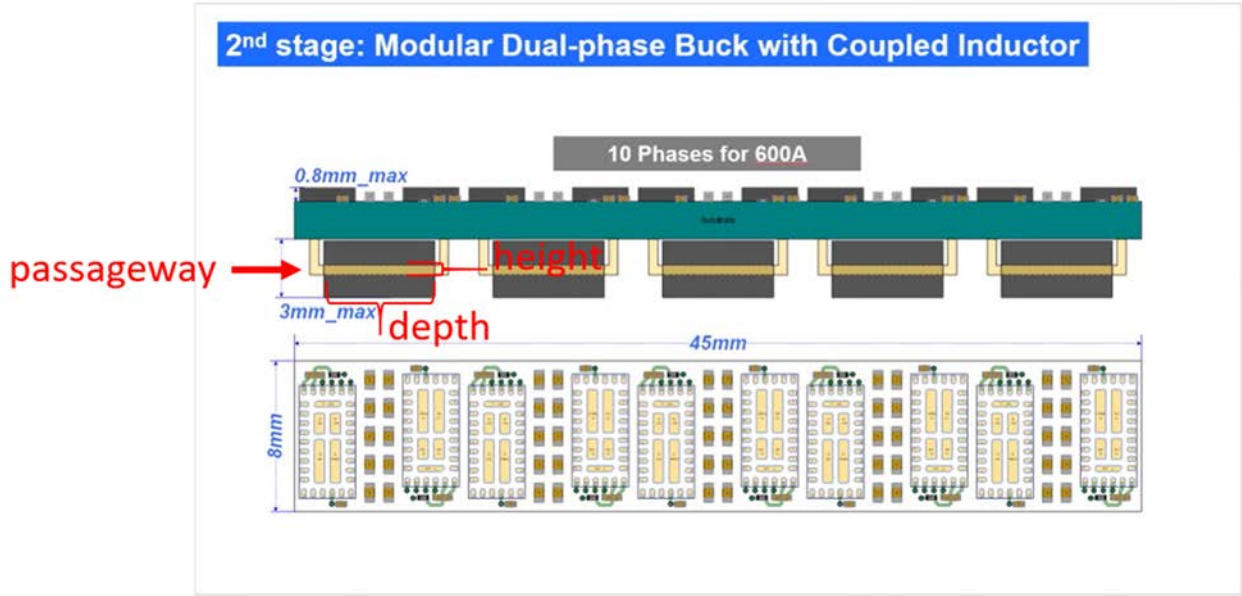

(<https://www.youtube.com/watch?v=w7CmBr1t3Ns> (annotation added)).

81. The two phase coupled inductors of the Accused Products include a first and a second winding having a same number of turns wound at least partially around a common leg of the magnetic core and through the passageway, the first and second windings separated by a linear



separation distance throughout the passageway the separation distance being along an axis perpendicular to an axis of the height of the passageway and perpendicular to an axis of the depth of the passageway, each winding having a respective first end and a respective second end, the second ends of the first and second windings being electrically connected to a common load, the cross-sectional area of the passageway between the windings being at least 50% free of magnetic material. For example, each two phase coupled inductor in the Accused Products includes two inductive windings having a single turn. The first and second inductive windings of each two phase coupled inductor are wound at least partially around a common leg of the magnetic core and through the passageway. The first and second windings are separated by a linear separation distance throughout the passageway, and the separation distance is along an axis perpendicular to an axis of the height of the passageway and perpendicular to an axis of the depth of the passageway. Each winding has a respective first end and a respective second end, and the second ends of the first and second windings are electrically connected to a common load. For example, Monolithic demonstrated using a “Dual-phase Buck” converter to regulate an output voltage of 1 volt from an intermediate input voltage of 5–8 volts at APEC 2019. The layout demonstrated at APEC 2019 indicates the intermediate input voltage is switched across the windings of the 2-phase coupled inductor by connecting one end of each winding to a common 1 volt output voltage and individually switching the other end of each winding between ground and the intermediate 5–8 volt input voltage. The cross-sectional area of the passageway between the windings is at least 50% free of magnetic material. For example, the layout demonstrated at APEC 2019 indicates that the first winding (shown in front) is separated from the second winding by a linear separation distance (into the page) perpendicular to an axis of the height of the passageway (up and down) and perpendicular to an axis of the depth of the passageway (left and right). The layout



demonstrated at APEC 2019 further indicates the use of coupled inductors to convert an intermediate input voltage to an output voltage of 1 volt, and the use of coupled inductors in the demonstrated power converter indicates that the cross-sectional area of the passageway between the windings is at least 50% free of magnetic material

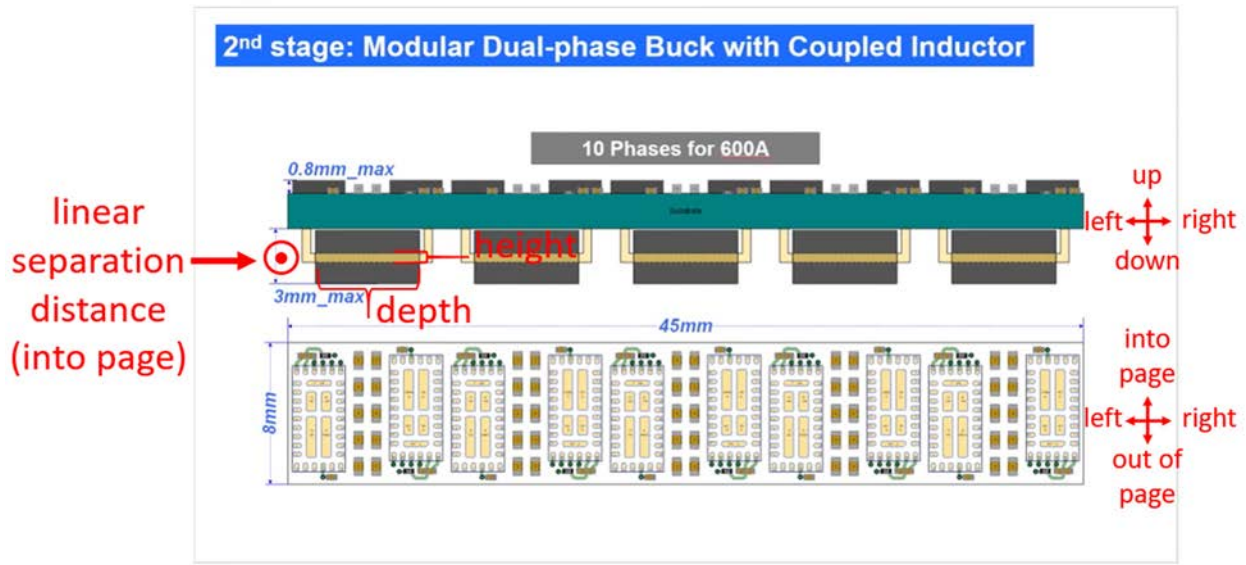

(<https://www.youtube.com/watch?v=w7CmBr1t3Ns> (annotation added)).

82. The Accused Products include a first switch electrically connected between a power source and the first end of the first winding; and a second switch electrically connected between the power source and the first end of the second winding; wherein the first and second switches independently and sequentially switch the first end of their respective winding to an input signal of the power source to regulate an output signal at the load. For example, the Accused Products include a pair of control circuits for each dual-phase coupled inductor. The first control circuit includes a first switch electrically connected between a power source and the first end of the first winding. The second control circuit includes a second switch electrically connected between a power source and the first end of the second winding. The first and second switches independently and sequentially switch the first end of their respective winding to an input signal of the power



source to regulate an output signal at the load. For example, Monolithic demonstrated using a “Dual-phase Buck” converter to regulate an output voltage of 1 volt from an intermediate input voltage of 5–8 volts at APEC 2019. The layout demonstrated at APEC 2019 indicates the intermediate input voltage is switched across the windings of the 2-phase coupled inductor by connecting one end of each winding to a common 1 volt output voltage and individually switching the other end of each winding between ground and the intermediate 5–8 volt input voltage.

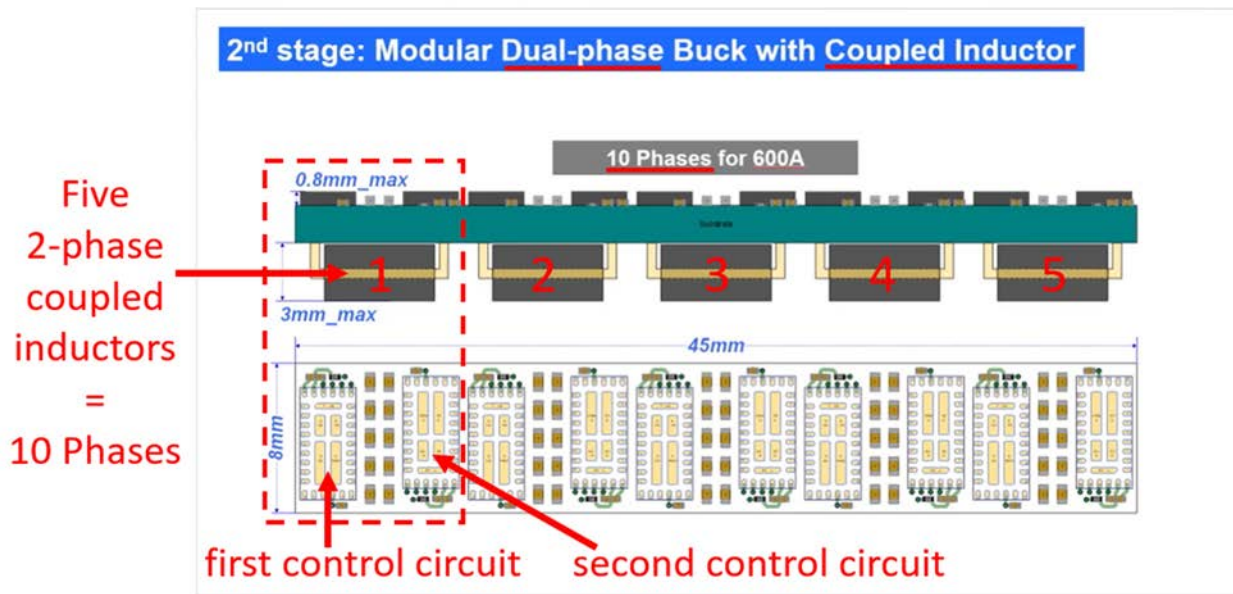

(<https://www.youtube.com/watch?v=w7CmBr1t3Ns> (annotation added)).

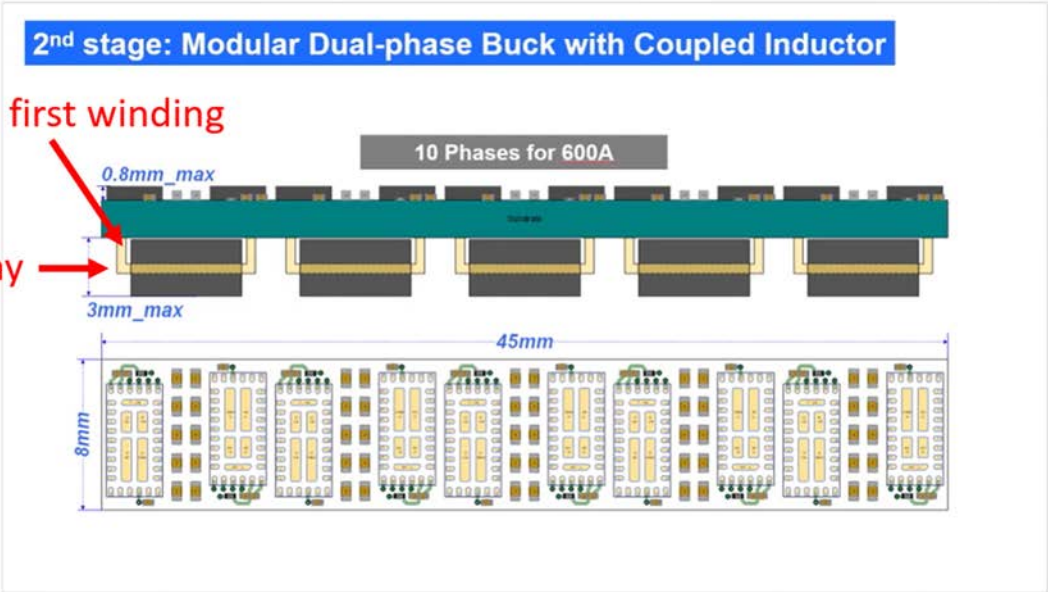

(<https://www.youtube.com/watch?v=w7CmBr1t3Ns> (annotation added)).

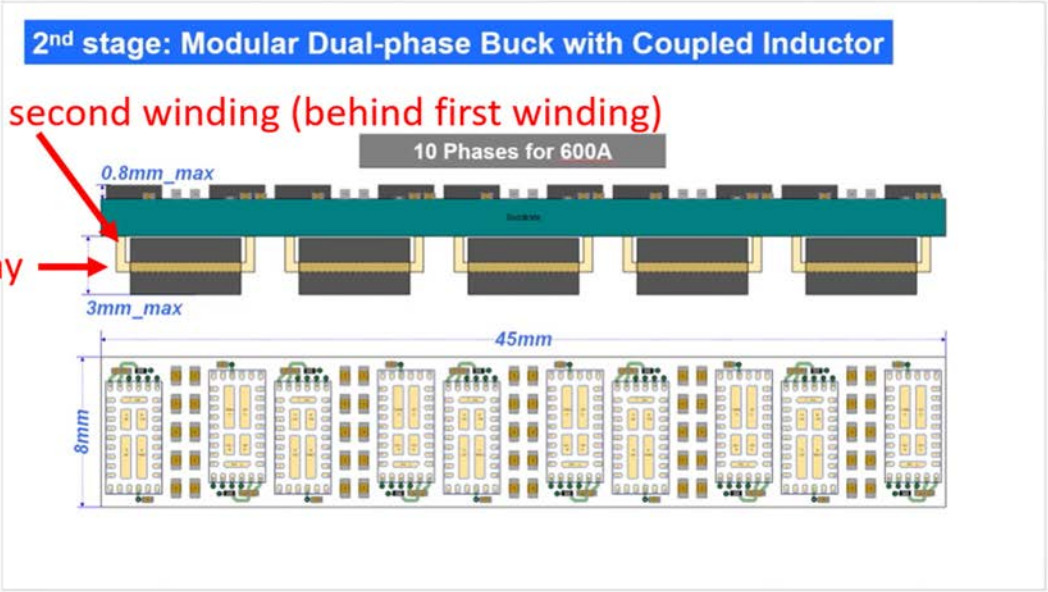

(<https://www.youtube.com/watch?v=w7CmBr1t3Ns> (annotation added)).

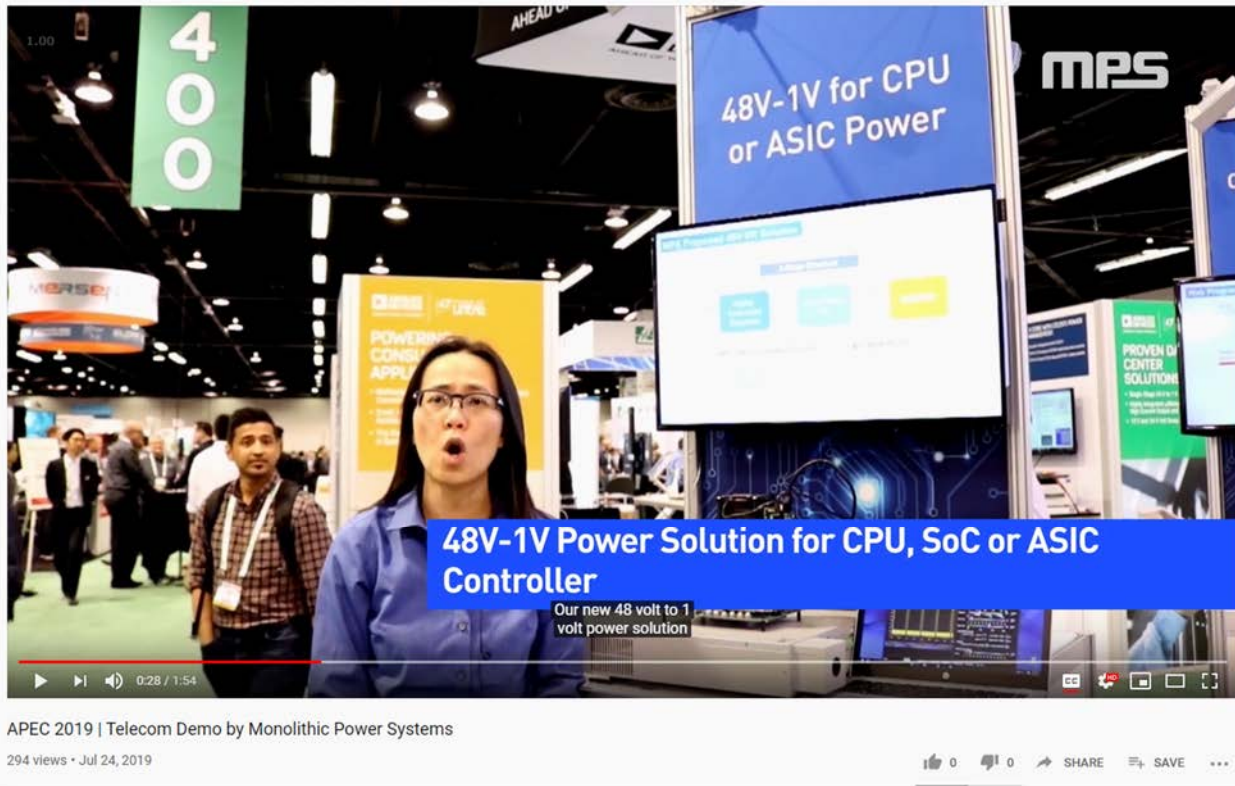

(<https://www.youtube.com/watch?v=w7CmBr1t3Ns>).

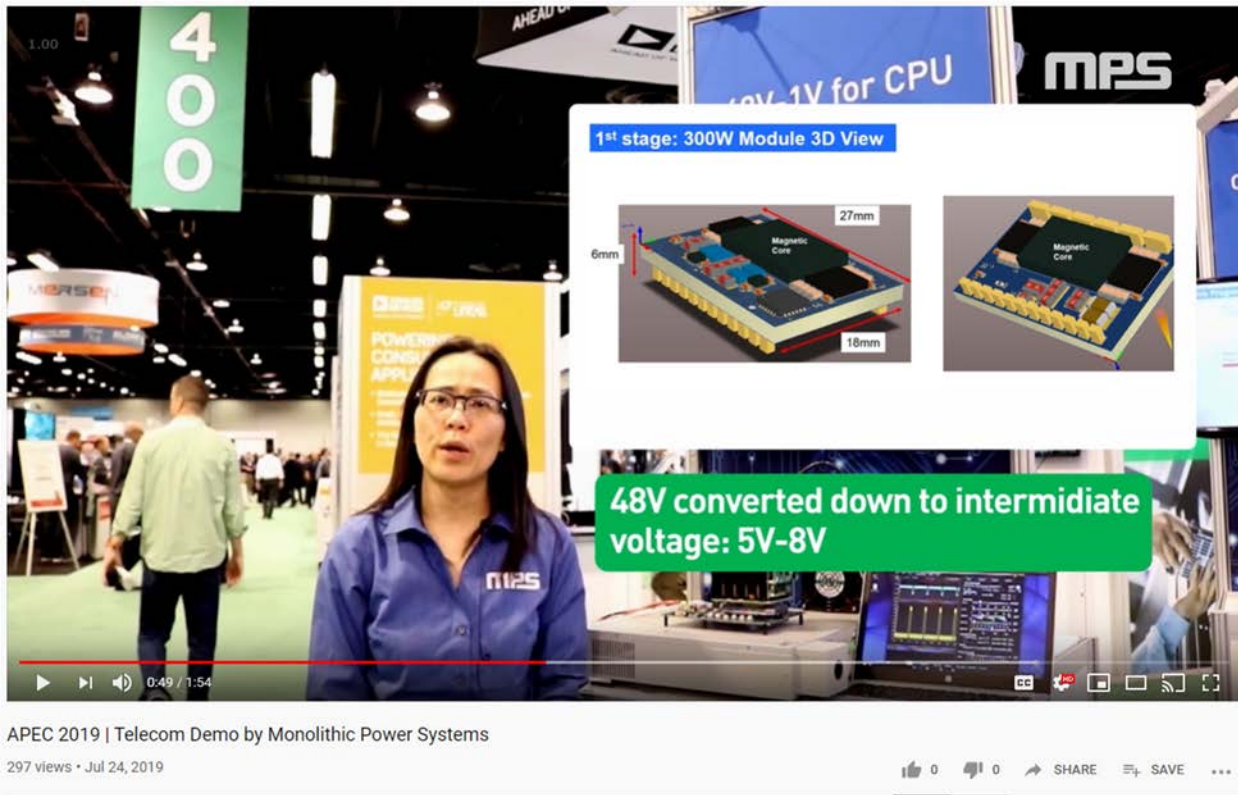



(<https://www.youtube.com/watch?v=w7CmBr1t3Ns>).

83. Claim 17 of the '955 patent recites: DC-to-DC converter of claim 16, the DC-to-DC converter configured and arranged such that: direct current flowing through the first winding from the first switch to the load generates a magnetic flux flowing in a first direction in the magnetic core; and direct current flowing through the second winding from the second switch to the load generates a magnetic flux flowing in a second direction in the magnetic core, the second direction being opposite of the first direction.

84. The Accused Products are a DC-to-DC converter configured and arranged such that direct current flowing through the first winding from the first switch to the load generates a magnetic flux flowing in a first direction in the magnetic core; and direct current flowing through the second winding from the second switch to the load generates a magnetic flux flowing in a second direction in the magnetic core, the second direction being opposite of the first direction. For example, the layout demonstrated at APEC 2019 indicates that the first control circuit is physically rotated 180 degrees with respect to the second control circuit. This physical orientation indicates that the DC-to-DC converter is configured and arranged such that direct current flows through the first winding from the first switch to the load and generates a magnetic flux flowing a first direction in the magnetic core. Direct current flows through the second winding from the second switch to the load in the opposite direction and generates a magnetic flux flowing in the opposite direction.

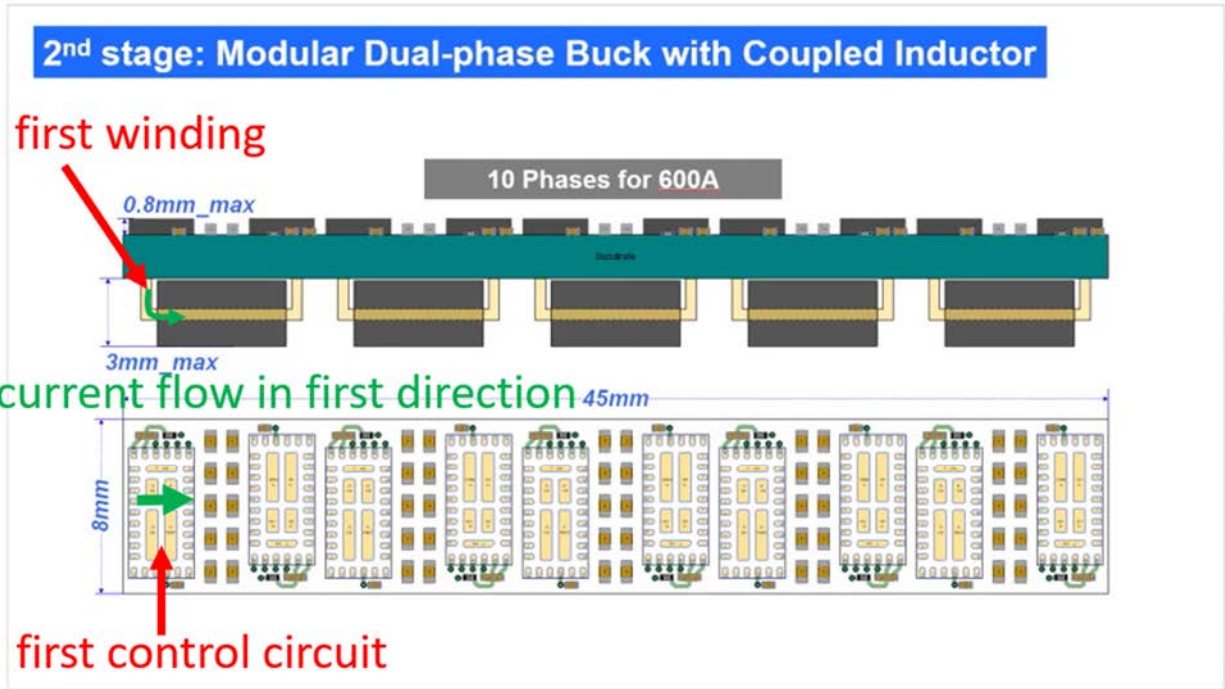

(<https://www.youtube.com/watch?v=w7CmBr1t3Ns> (annotation added)).

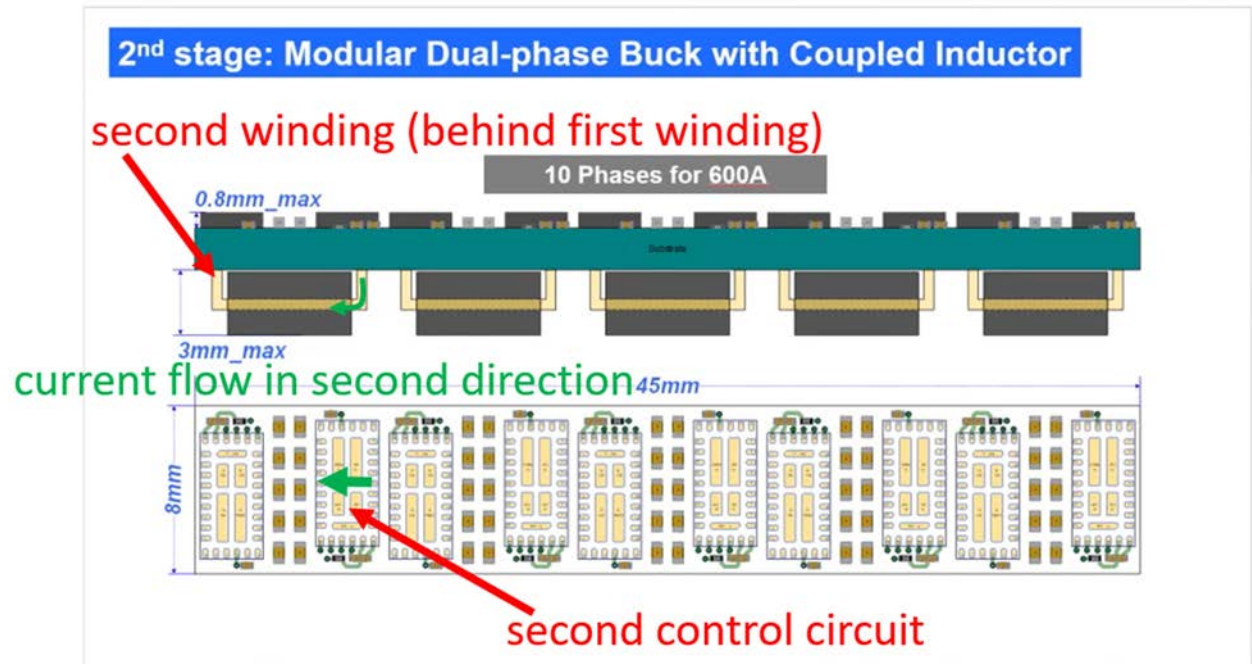

(<https://www.youtube.com/watch?v=w7CmBr1t3Ns> (annotation added)).

85. Claim 18 of the '955 patent recites: DC-to-DC converter of claim 17, the separation distance being greater than the height of the passageway.



86. The Accused Products include a separation distance being greater than the height of the passageway. For example, the layout demonstrated at APEC 2019 describes outputting 600A of current, and the ability to achieve this high current from the design demonstrated in the layout indicates that the separation distance is greater than the height of the passageway shown.

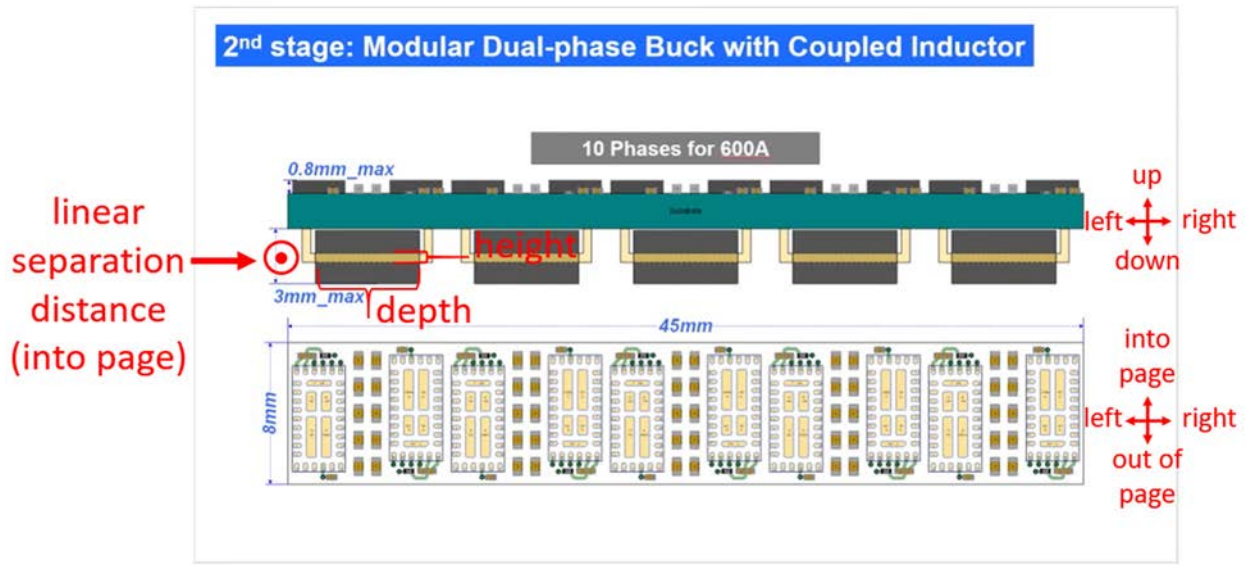

(<https://www.youtube.com/watch?v=w7CmBr1t3Ns> (annotation added)).

87. Claim 19 of the '955 patent recites: DC-to-DC converter of claim 17, a switching cycle of the first switch being about 180 degrees out of phase with a switching cycle of the second switch.

88. The Accused Products include a switching cycle of the first switch being about 180 degrees out of phase with a switching cycle of the second switch. For example, the layout demonstrated at APEC 2019 is titled “Modular *Dual-phase* Buck with *Coupled Inductor*” and “*10 Phases* for 600A,” indicating that each of the five inductors pictured is a 2-phase coupled inductor such that the total amounts to “10 Phases.” Likewise, Monolithic’s demonstration at APEC 2019 discussed an 8-phase power converter, and the video displayed a board with four pairs of control circuits instead of the five pairs shown in the 10-phase layout. The layout and video both show



the first control circuit's physical orientation with respect to the second control circuit, and the physical orientation of the control circuits is further evidence that each coupled inductor is a 2-phase coupled inductor. The use of 2-phase coupled inductors in the layout demonstrated at APEC 2019 is indicative of the first switch being about 180 degrees out of phase with a switching cycle of the second switch.

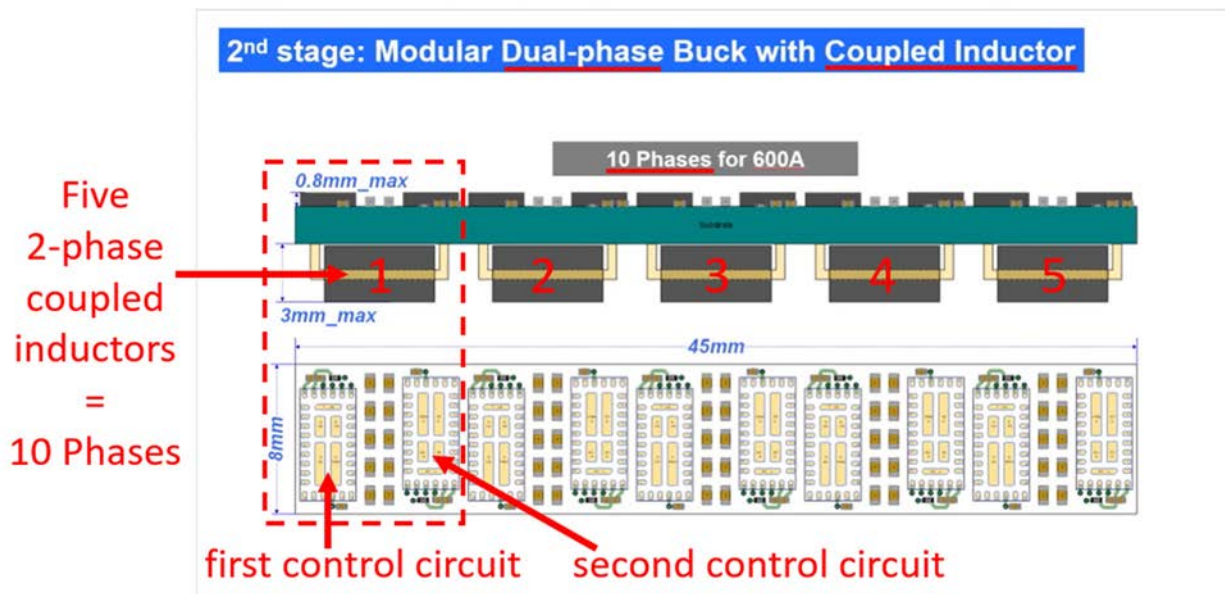

(<https://www.youtube.com/watch?v=w7CmBr1t3Ns> (annotation added)).

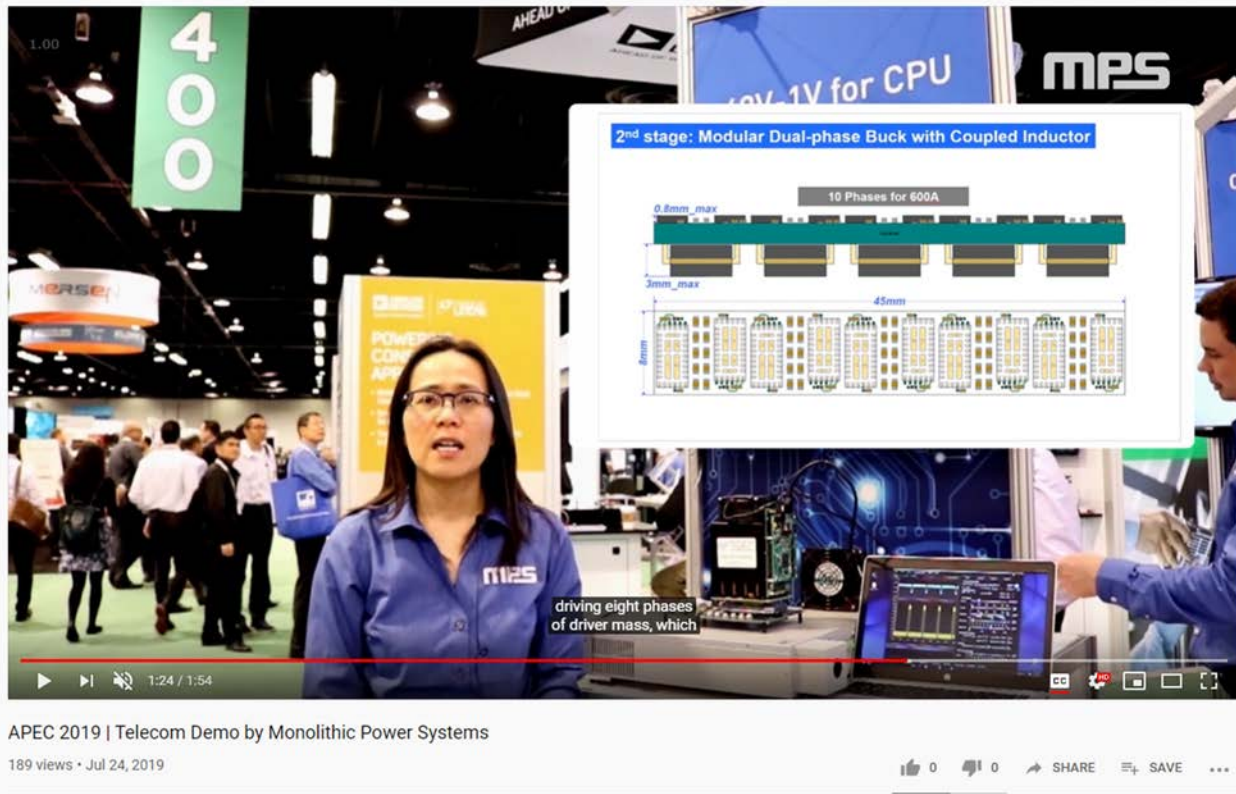

(<https://www.youtube.com/watch?v=w7CmBr1t3Ns>).

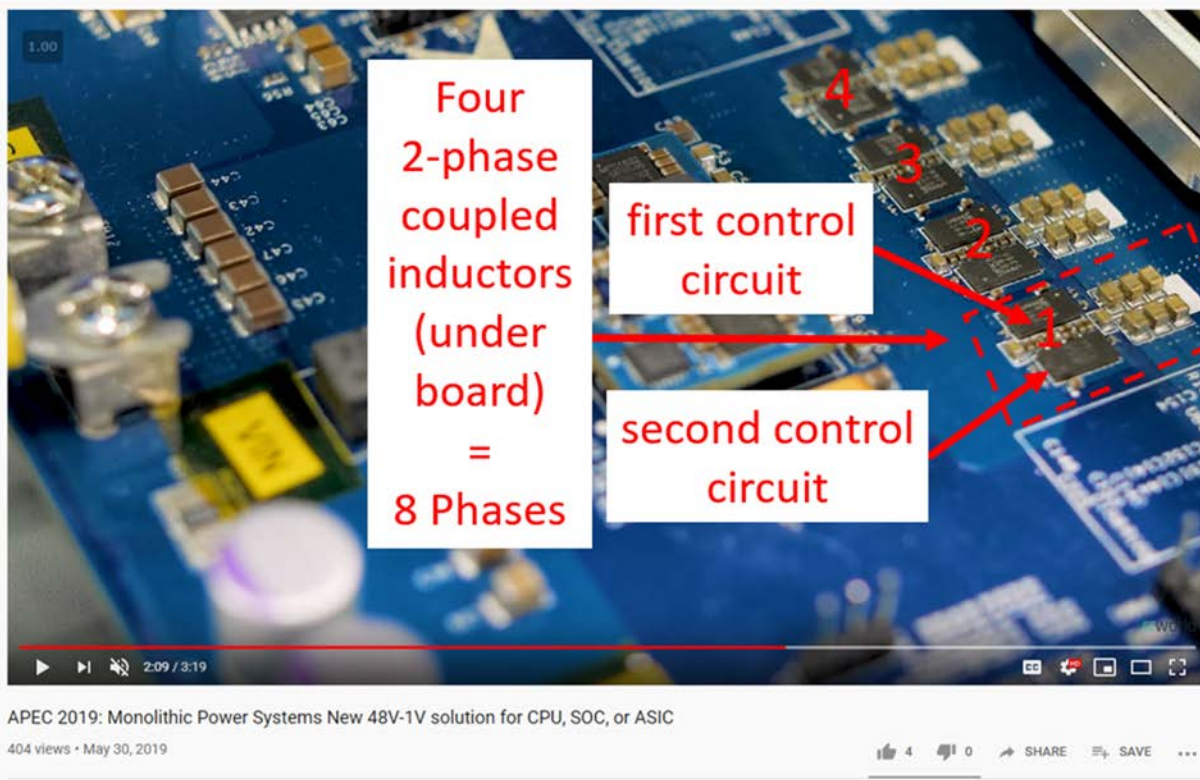



(<https://www.youtube.com/watch?v=WIC2SDWSins> (annotation added)).

89. Claim 20 of the '955 patent recites: DC-to-DC converter of claim 17, the first and second windings being single turn windings.

90. The Accused Products include first and second windings being single turn windings. For example, the layout demonstrated at APEC 2019 indicates the first and second windings are single turn windings.

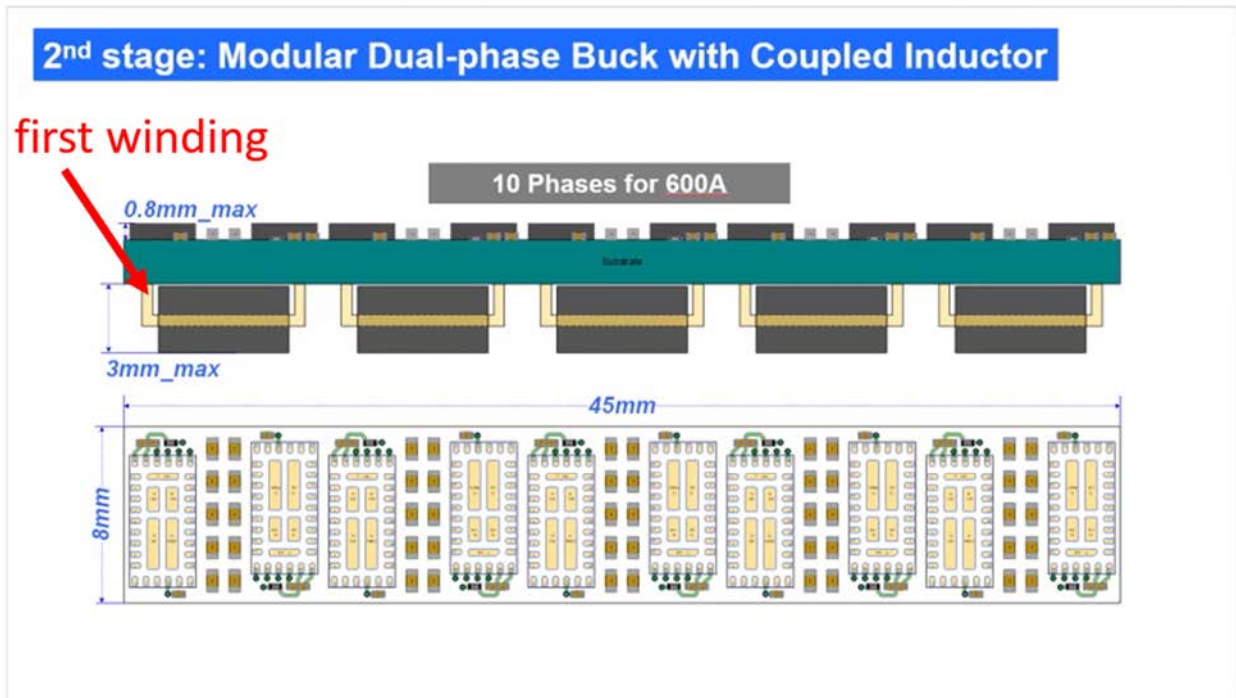

(<https://www.youtube.com/watch?v=w7CmBr1t3Ns> (annotation added)).

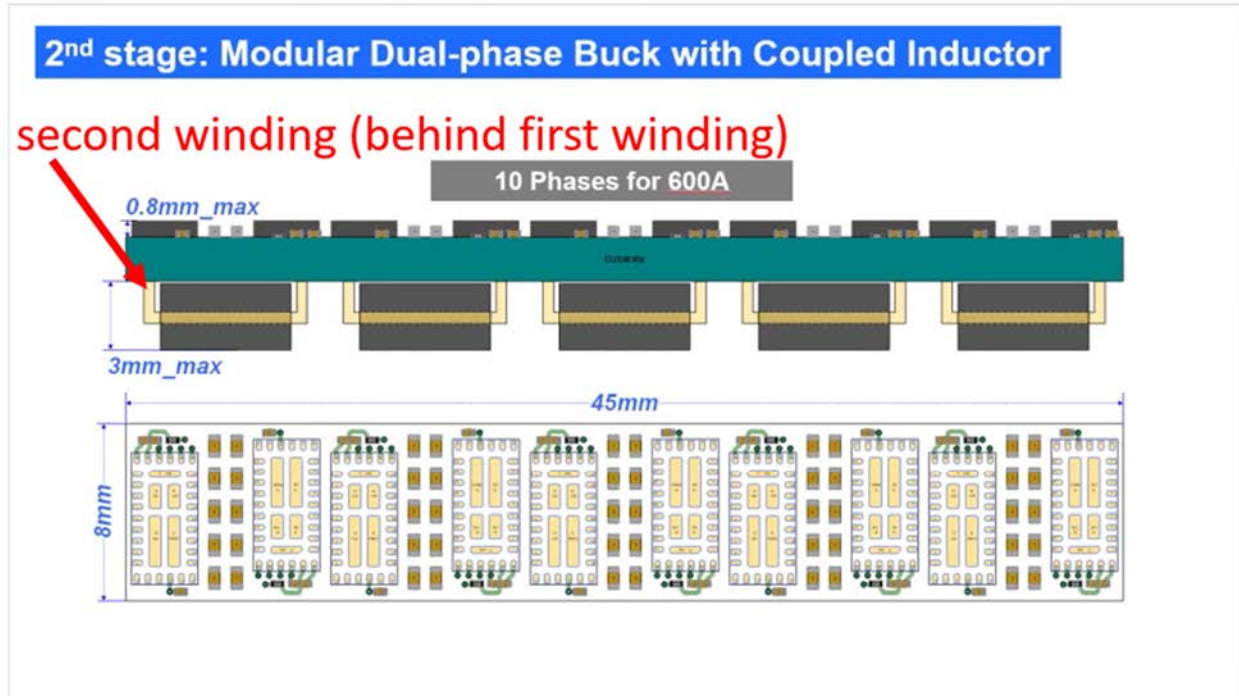

(<https://www.youtube.com/watch?v=w7CmBr1t3Ns> (annotation added)).

91. Claim 21 of the '955 patent recites: DC-to-DC converter of claim 17, the magnetic core forming a single passageway.

92. The Accused Products include a magnetic core forming a single passageway. For example, the layout demonstrated at APEC 2019 indicates that the first winding (shown in front) of each 2-phase coupled inductor is separated from the second winding of each 2-phase coupled inductor by a linear separation distance (into the page). If this linear separation distance was filled with magnetic material such that more than a single passageway existed in the magnetic core, the first winding and the second winding would be unable to couple and the device demonstrated by MPS would not be a 2-phase coupled inductor. Therefore, the magnetic core in each coupled inductor forms a single passageway.

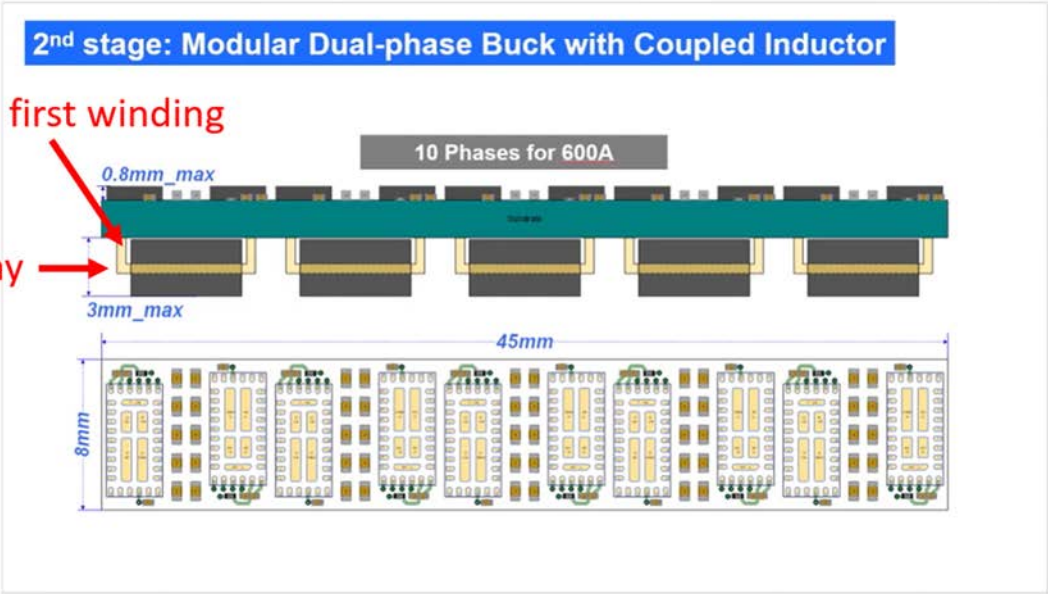

(<https://www.youtube.com/watch?v=w7CmBr1t3Ns> (annotation added)).

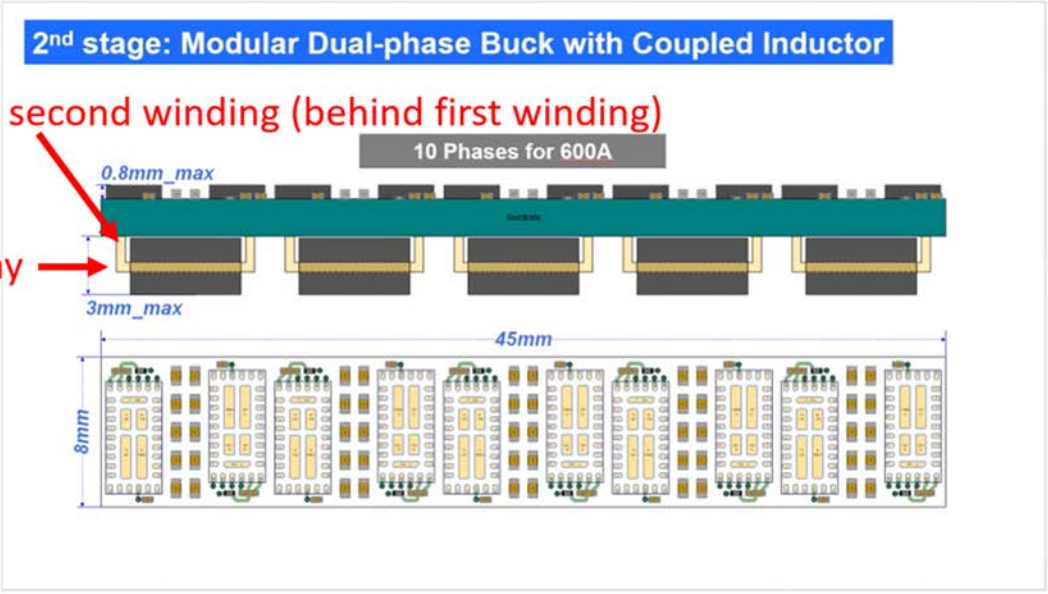

(<https://www.youtube.com/watch?v=w7CmBr1t3Ns> (annotation added)).

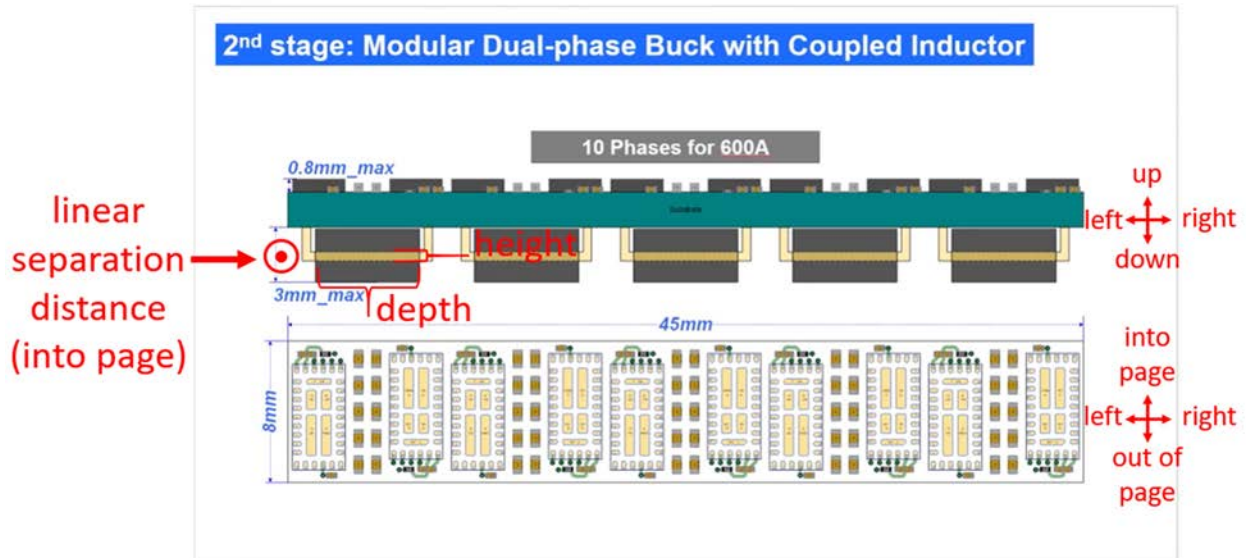

(<https://www.youtube.com/watch?v=w7CmBr1t3Ns> (annotation added)).

93. Claim 23 of the '955 patent recites: A two phase coupled inductor for magnetically coupling first and second phases of a power converter, comprising: a magnetic core forming a passageway at least partially defined by first, second, third, and fourth planar surfaces of the magnetic core, the first planar surface being opposite of the second planar surface, the third planar surface being opposite of the fourth planar surface; a first winding providing electrical interface for the first phase, the first winding wound at least partly about the magnetic core and passing through the passageway along the first planar surface and contacting the third planar surface; and a second winding providing electrical interface for the second phase, the second winding wound at least partly about the magnetic core and passing through the passageway along the first planar surface and contacting the fourth planar surface, the passageway having depth and height, the depth being greater than the height, the first and second windings extending through the magnetic core only via the passageway, and the first and second windings being separated by a linear separation distance throughout the passageway, the separation distance being along an axis



perpendicular to an axis of the height of the passageway and perpendicular to an axis of the depth of the passageway, the separation distance being greater than the height of the passageway.

94. The Accused Products include a two phase coupled inductor for magnetically coupling first and second phases of a power converter. For example, the Accused Products include multiple two phase coupled inductors for magnetically coupling first and second phases of a DC-to-DC power converter. Monolithic’s demonstration at APEC 2019 discussed an 8-phase power converter and included a layout of a 10-phase power converter. The layout of the 10-phase power converter showed five 2-phase coupled inductors. Likewise, the video displayed an 8-phase power converter’s board with four pairs of control circuits instead of the five pairs shown in the 10-phase layout.

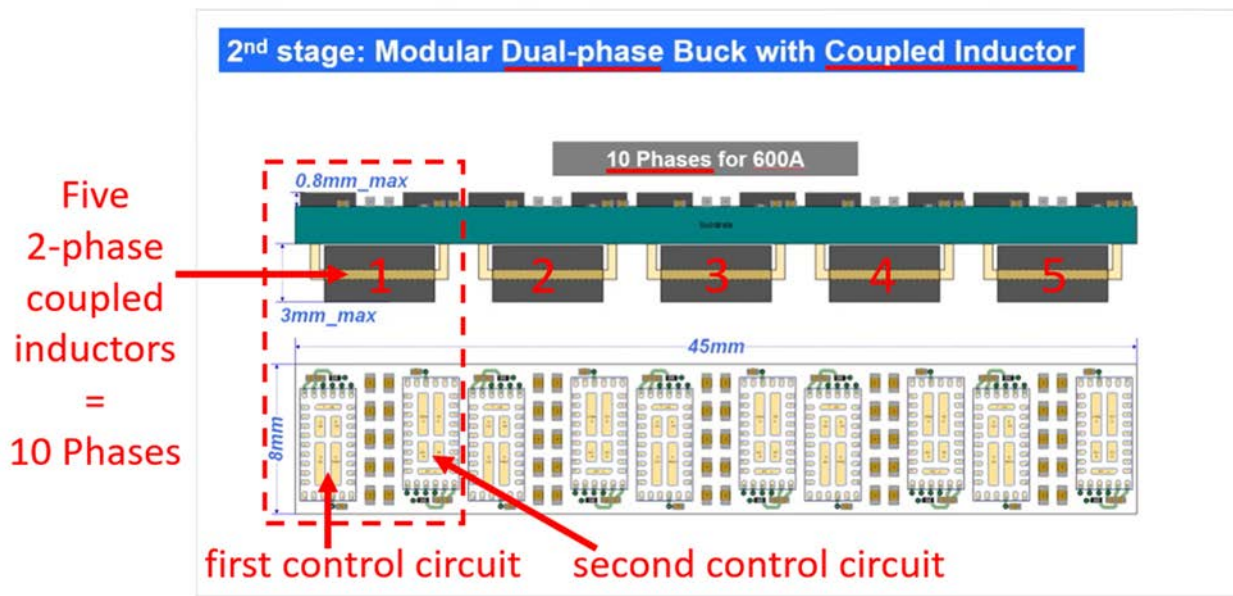

(<https://www.youtube.com/watch?v=w7CmBr1t3Ns> (annotation added)).

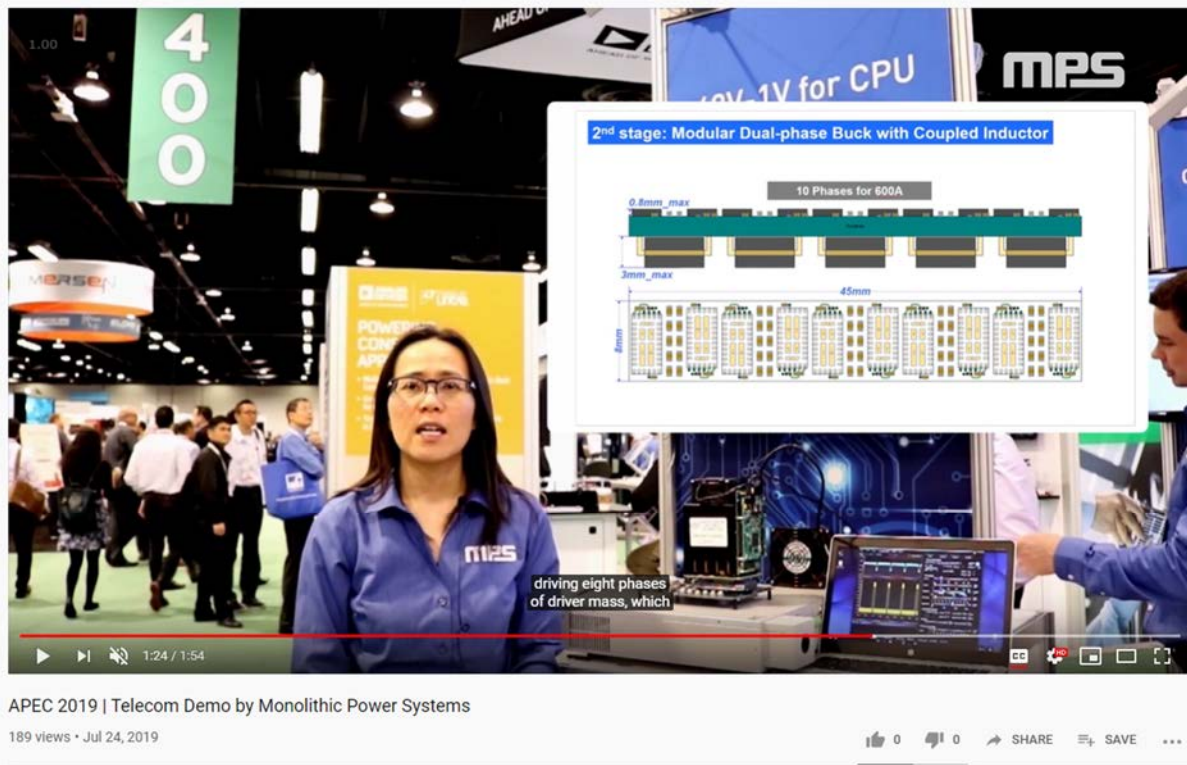

(<https://www.youtube.com/watch?v=w7CmBr1t3Ns>).

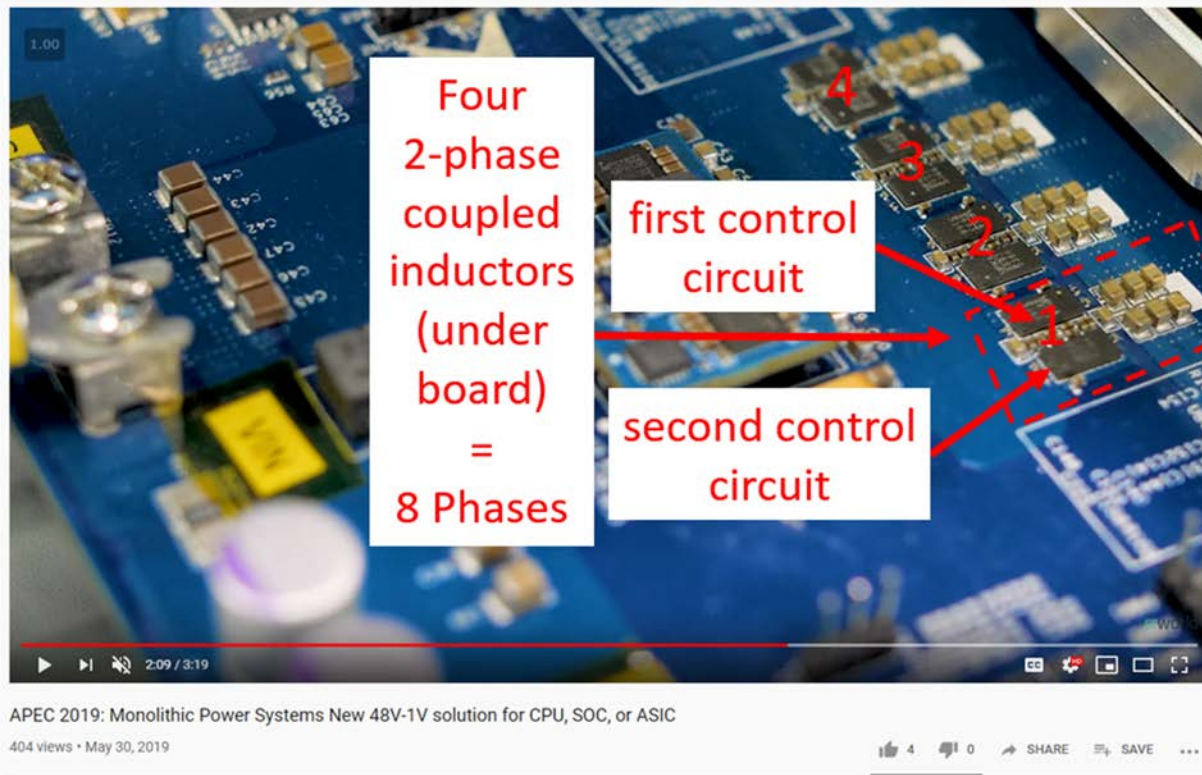



(<https://www.youtube.com/watch?v=WIC2SDWSins> (annotation added)).

95. The Accused Products include a magnetic core forming a passageway at least partially defined by first, second, third, and fourth planar surfaces of the magnetic core, the first planar surface being opposite of the second planar surface, the third planar surface being opposite of the fourth planar surface. For example, the Accused Products include two phase coupled inductors, and each coupled inductor includes a magnetic core. Each magnetic core includes a first and second magnetic element and two connecting magnetic elements. The first and second magnetic elements include first and second planar surfaces opposite to one another, and the two connecting magnetic elements include third and fourth planar surfaces opposite to one another. A passageway is formed by the first and second magnetic elements and the two connecting magnetic elements.

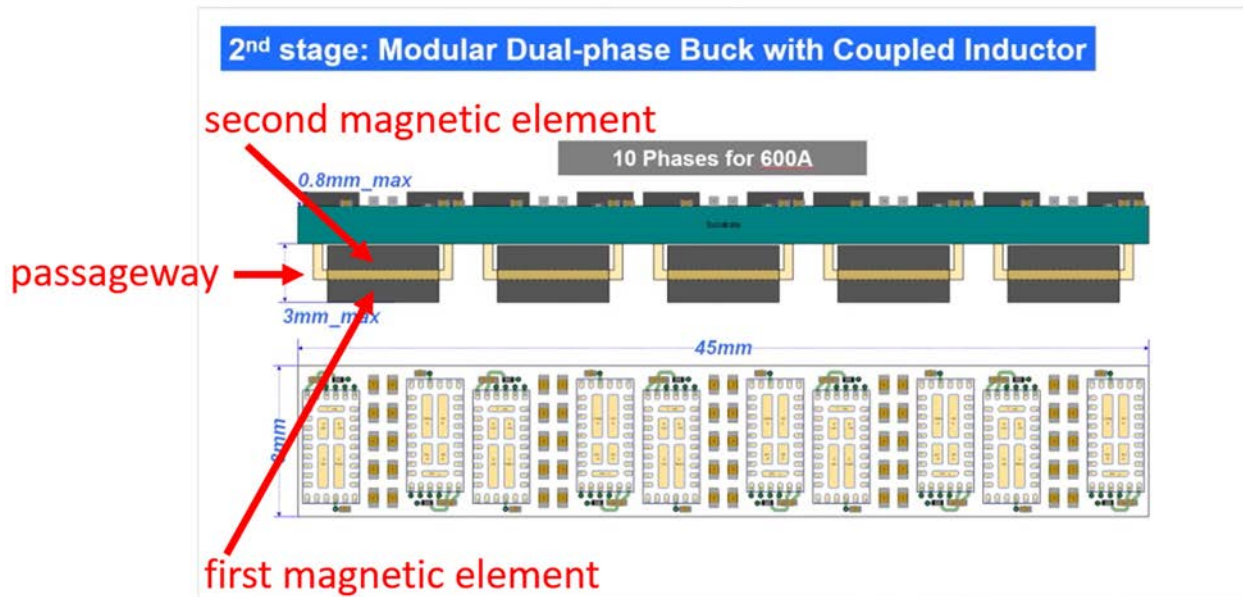

(<https://www.youtube.com/watch?v=w7CmBr1t3Ns> (annotation added)).

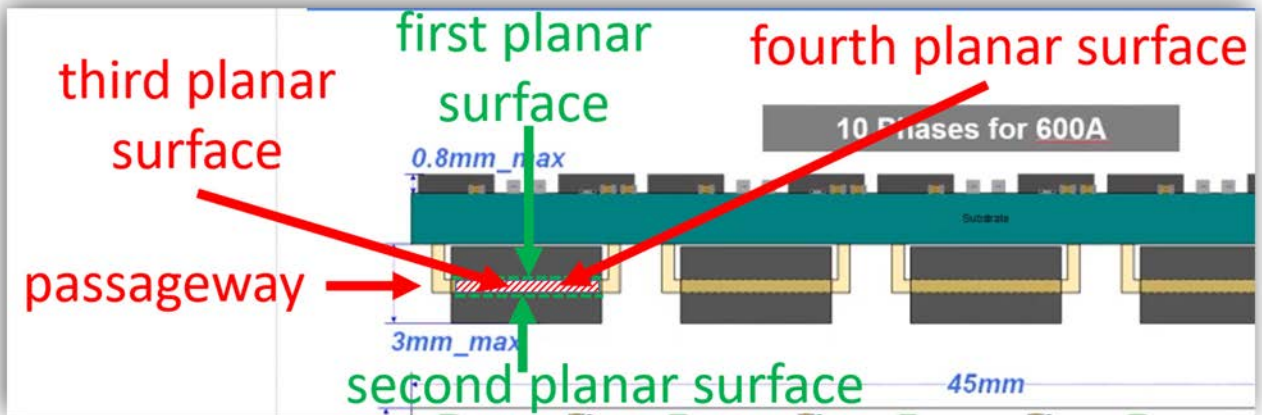
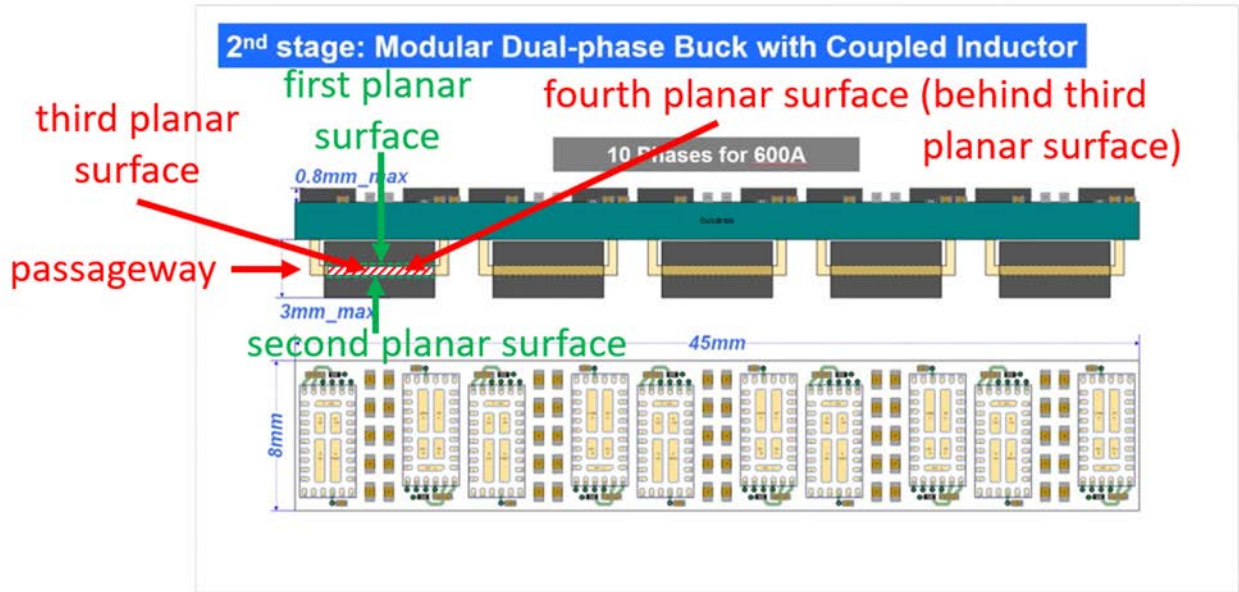

(<https://www.youtube.com/watch?v=w7CmBr1t3Ns> (annotation added)).

96. The Accused Products include a first winding providing electrical interface for the first phase, the first winding wound at least partly about the magnetic core and passing through the passageway along the first planar surface and contacting the third planar surface. For example, each two phase coupled inductor in the Accused Products includes two inductive windings. The first inductive winding is wound about and contacts the third planar surface of connecting magnetic element of the magnetic core and passes through the passageway along the first planar surface of the second magnetic element.

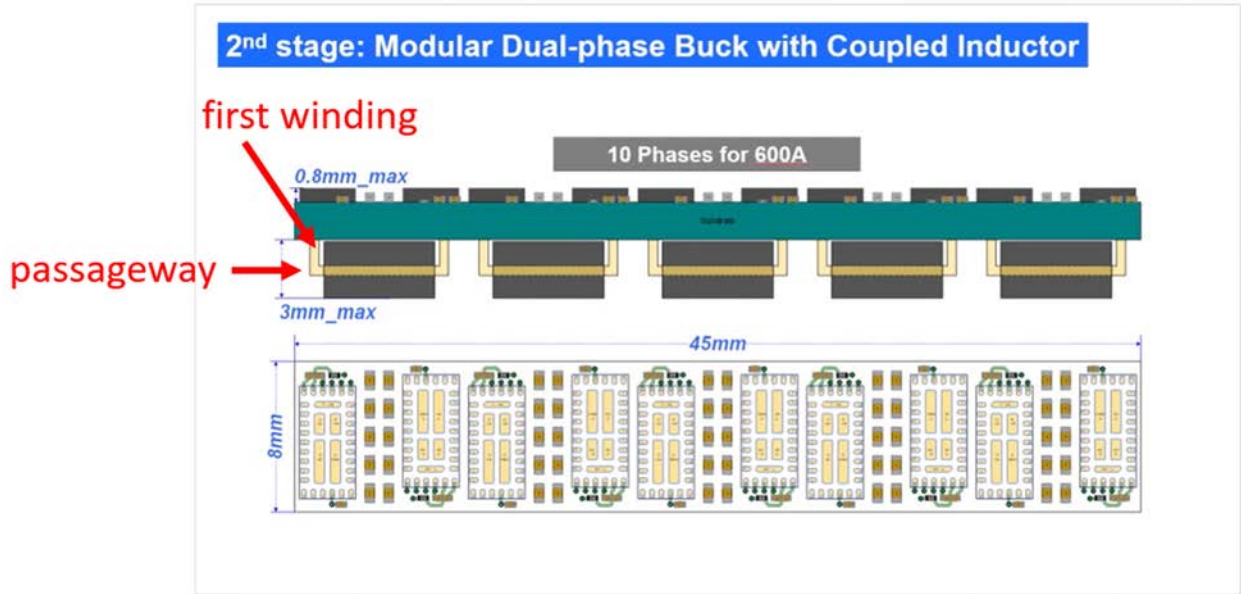

(<https://www.youtube.com/watch?v=w7CmBr1t3Ns> (annotation added)).

97. The Accused Products include a second winding providing electrical interface for the second phase, the second winding wound at least partly about the magnetic core and passing through the passageway along the first planar surface and contacting the fourth planar surface. For example, each two phase coupled inductor in the Accused Products includes two inductive windings. The second inductive winding is wound about and contacts the fourth planar surface of the connecting magnetic element of the magnetic core and passes through the passageway along the first planar surface of the second magnetic element.

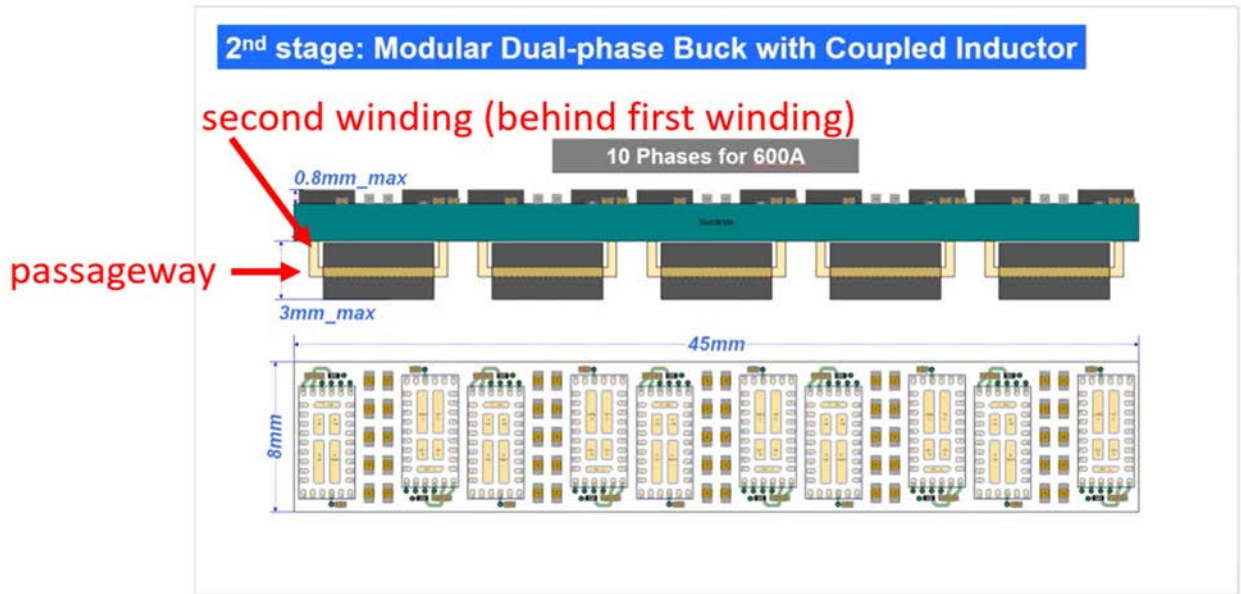

(<https://www.youtube.com/watch?v=w7CmBr1t3Ns> (annotation added)).

98. The Accused Products have the passageway having depth and height, the depth being greater than the height. For example, the Accused Products include two phase coupled inductors, and each coupled inductor includes a magnetic core. Each magnetic core includes a passageway formed by the first and second magnetic elements and the two connecting magnetic elements, and the depth of this passageway is greater than its height. For example, the layout demonstrated at APEC 2019 indicates that the depth of the passageway is greater than the height of the passageway.

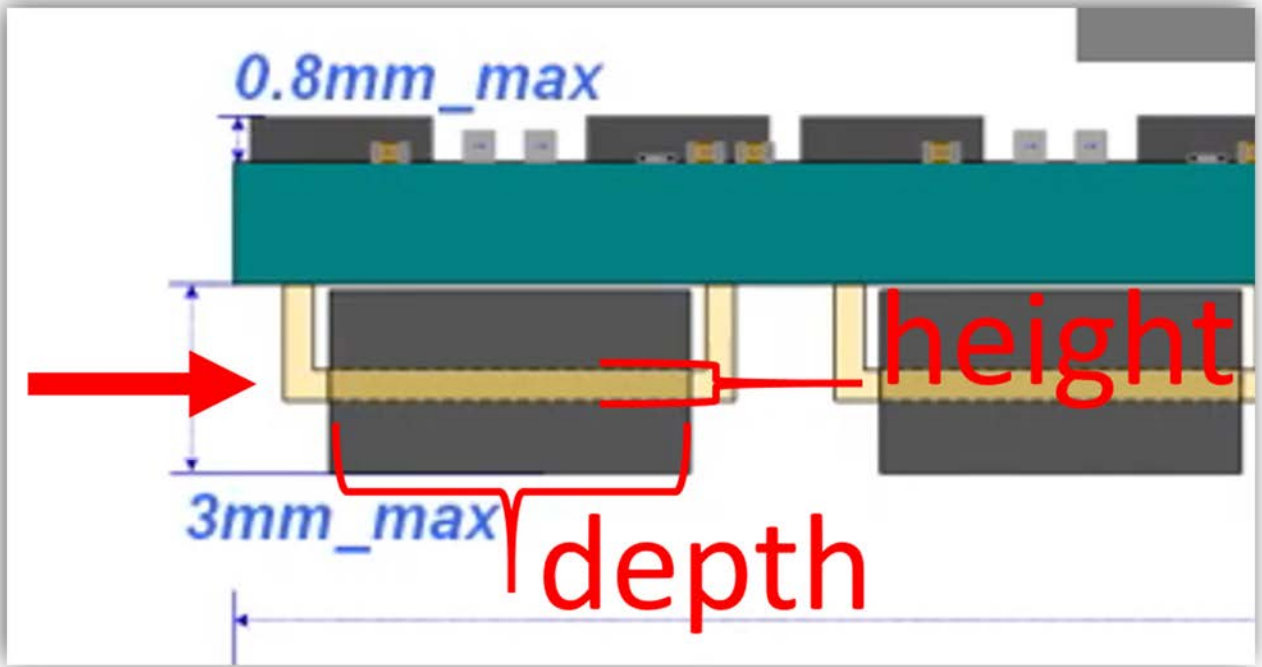
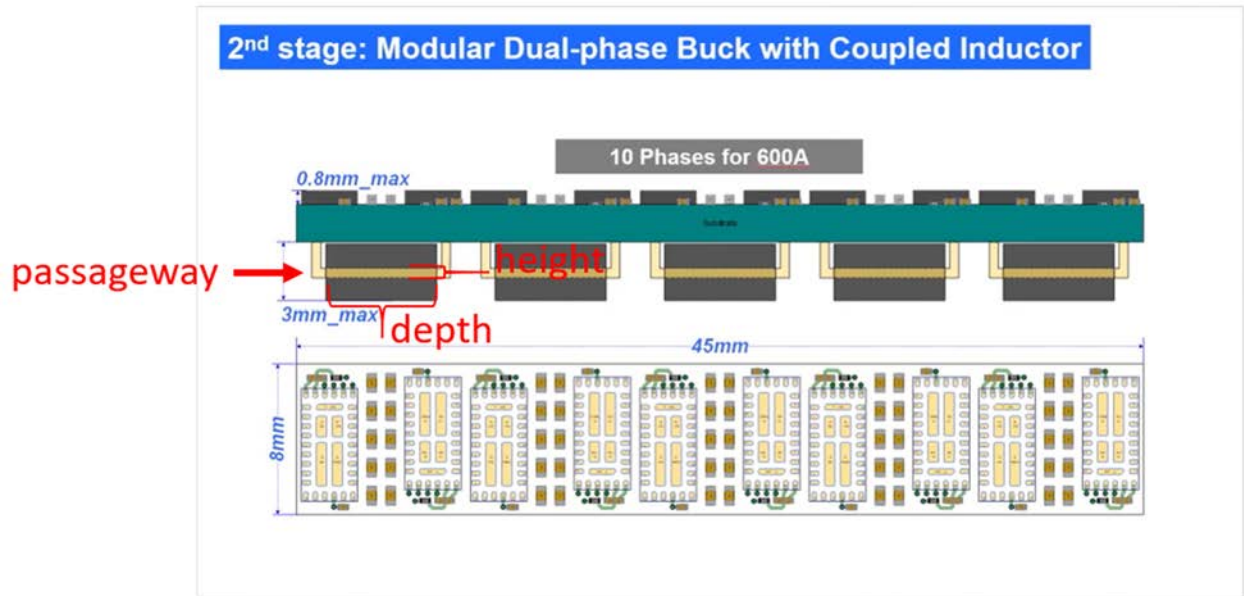

(<https://www.youtube.com/watch?v=w7CmBr1t3Ns> (annotation added)).

99. The Accused Products have the first and second windings extending through the magnetic core only via the passageway. For example, each two phase coupled inductor in the



Accused Products includes two inductive windings, and both inductive windings extend through the magnetic core only via the passageway.

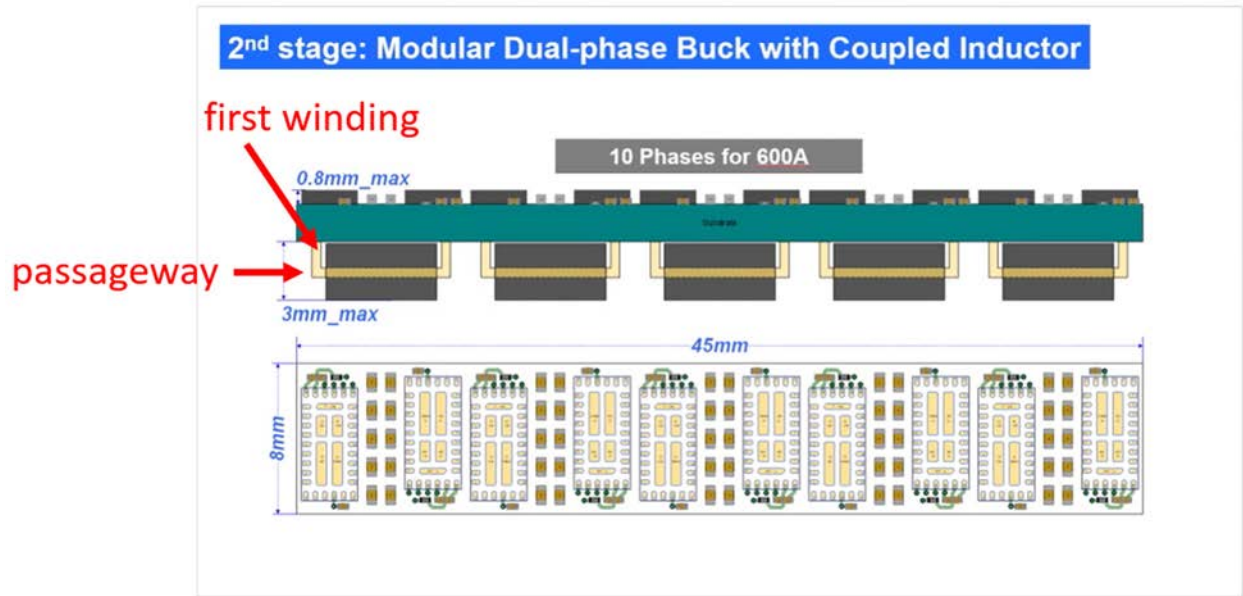

(<https://www.youtube.com/watch?v=w7CmBr1t3Ns> (annotation added)).

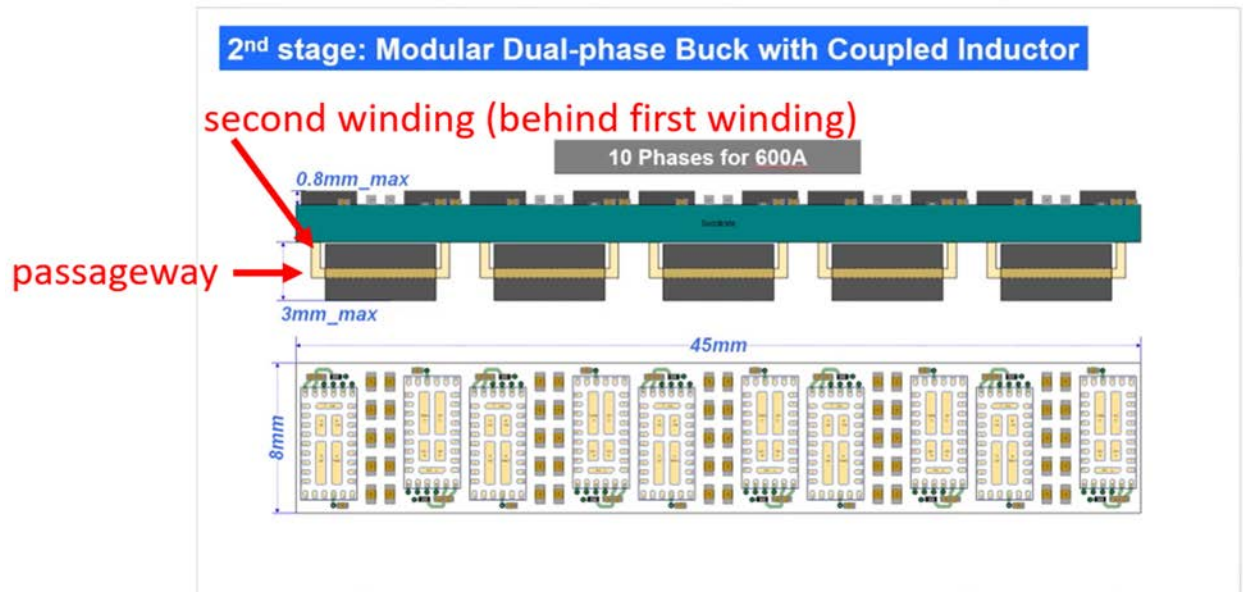

(<https://www.youtube.com/watch?v=w7CmBr1t3Ns> (annotation added)).



100. The Accused Products have the first and second windings being separated by a linear separation distance throughout the passageway, the separation distance being along an axis perpendicular to an axis of the height of the passageway and perpendicular to an axis of the depth of the passageway, the separation distance being greater than the height of the passageway. For example, each two phase coupled inductor in the Accused Products includes two inductive windings. The first inductive winding contacts the third planar surface of the connecting magnetic element of the magnetic core and the second inductive winding contacts the fourth planar surface of the connecting magnetic element of the magnetic core. As such, the first and second windings are separated by a linear separation distance throughout the passageway, and the separation distance is along an axis perpendicular to an axis of the height of the passageway and perpendicular to an axis of the depth of the passageway. The separation distance is greater than the height of the passageway. For example, the layout demonstrated at APEC 2019 indicates that the first winding (shown in front) is separated from the second winding by a linear separation distance (into the page) perpendicular to an axis of the height of the passageway (up and down) and perpendicular to an axis of the depth of the passageway (left and right). The layout demonstrated at APEC 2019 further indicates that the separation distance is greater than the height of the passageway. For example, the layout describes outputting 600A of current, and the ability to achieve this high current from the design demonstrated in the layout indicates that the separation distance is greater than the height of the passageway shown.

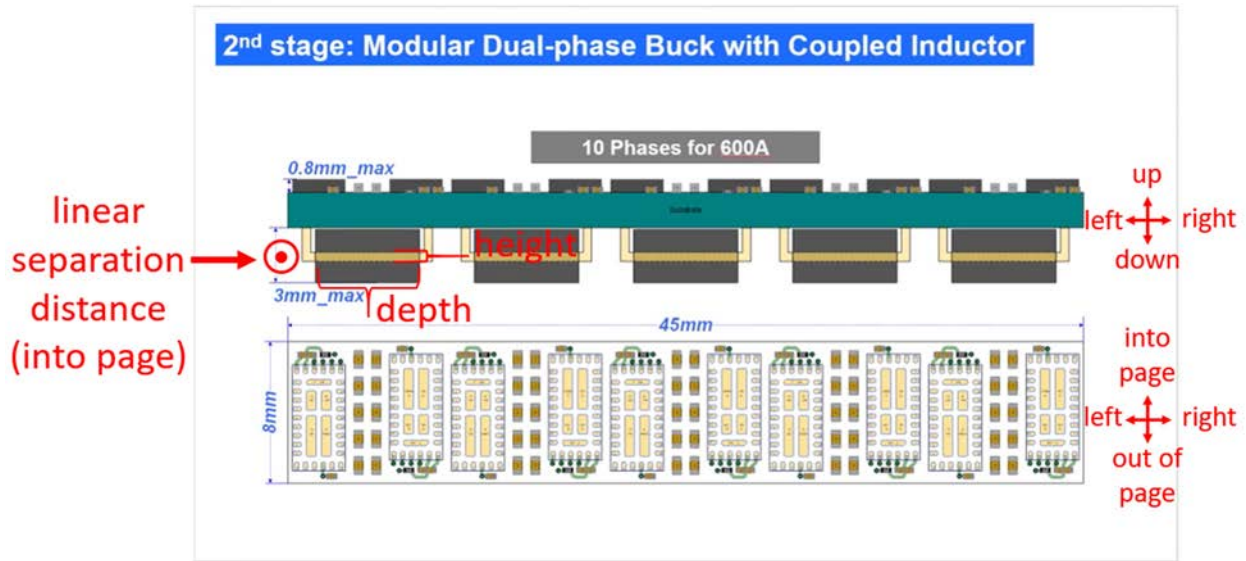

(<https://www.youtube.com/watch?v=w7CmBr1t3Ns> (annotation added)).

101. Claim 24 of the '955 patent recites: Two phase coupled inductor of claim 23, the depth and height of the passageway defining a cross sectional area of the passageway, and the cross sectional area of the passageway between the first and second windings being at least partially free from intervening magnetic structure.

102. The Accused Products include a depth and height of the passageway defining a cross sectional area of the passageway, and the cross sectional area of the passageway between the first and second windings being at least partially free from intervening magnetic structure. For example, the layout demonstrated at APEC 2019 indicates the passageway has a depth and height defining a cross sectional area of the passageway. The layout demonstrated further indicates the use of coupled inductors to convert an intermediate input voltage to an output voltage of 1 volt, and the use of coupled inductors in the demonstrated power converter indicates that the cross-sectional area of the passageway between the first and second windings is at least partially free of magnetic structure. For example, the layout demonstrated at APEC 2019 indicates that the first



winding (shown in front) of each 2-phase coupled inductor is separated from the second winding of each 2-phase coupled inductor by a linear separation distance (into the page). If this linear separation distance was filled with intervening magnetic structure, the first winding and the second winding would be unable to couple and the device demonstrated by MPS would not be a 2-phase coupled inductor.

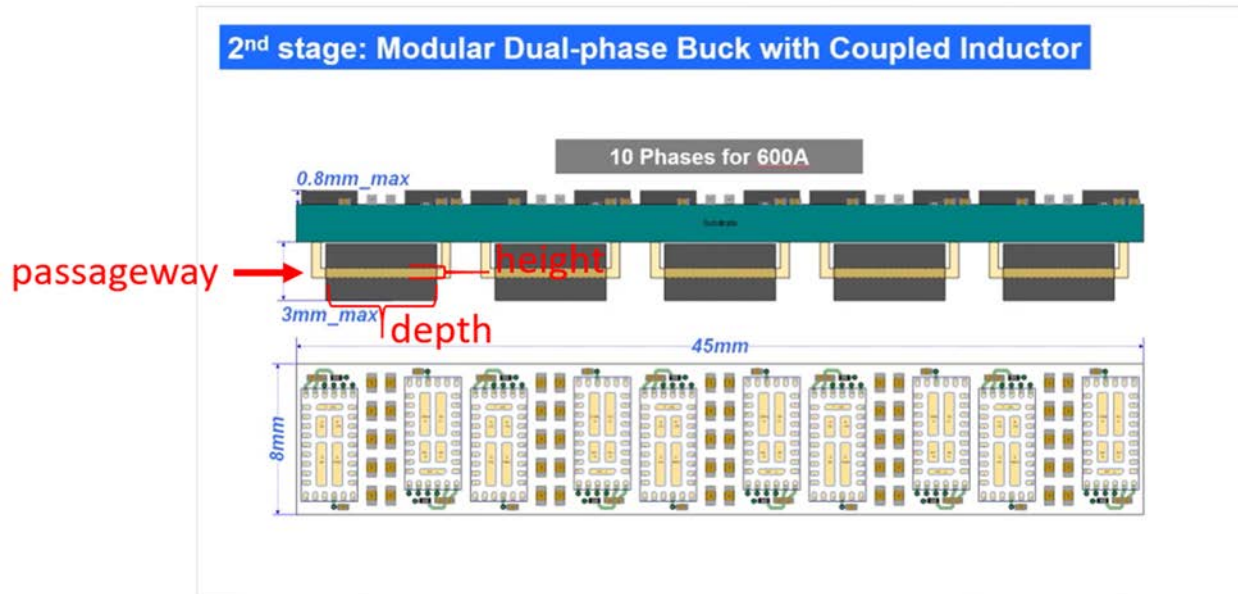

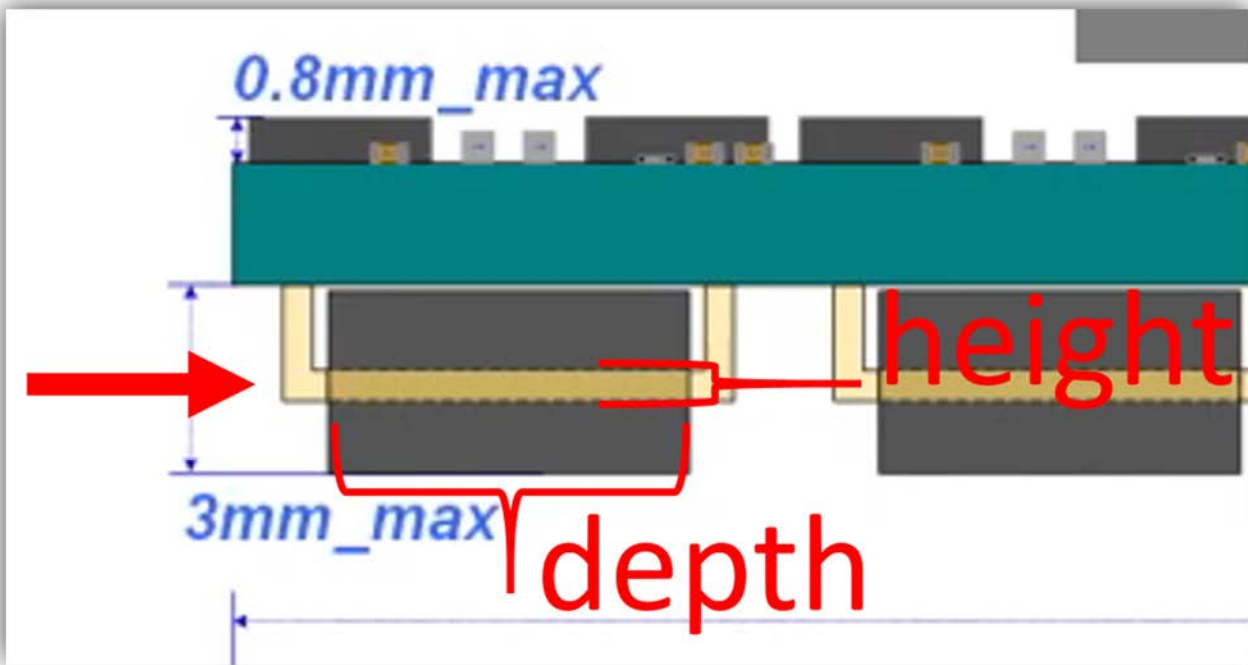

(<https://www.youtube.com/watch?v=w7CmBr1t3Ns> (annotation added)).

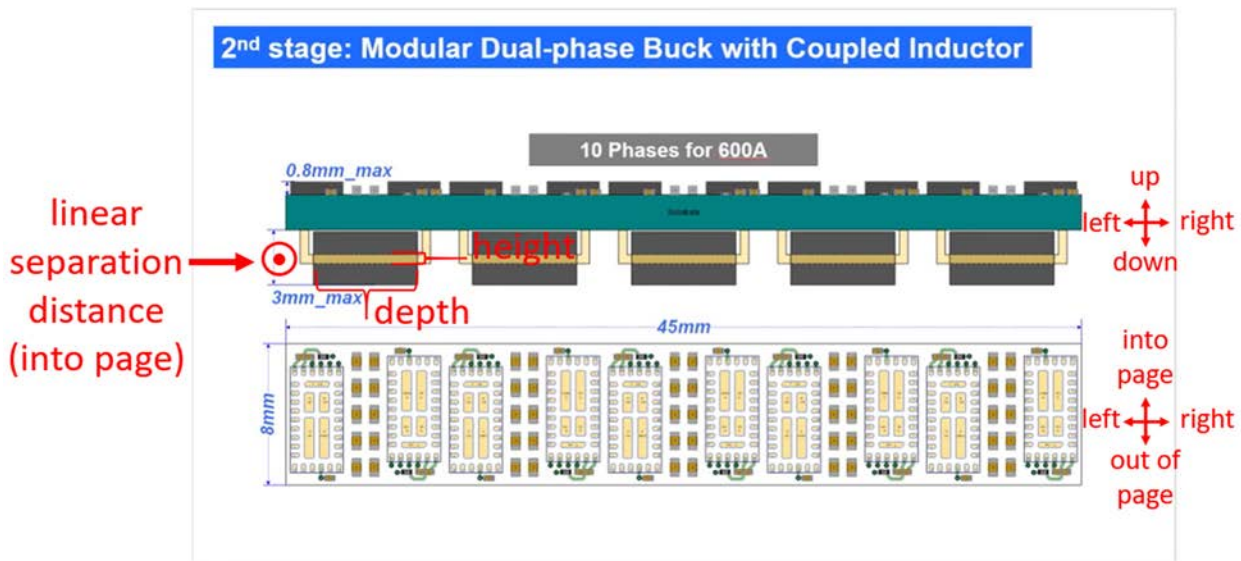

(<https://www.youtube.com/watch?v=w7CmBr1t3Ns> (annotation added)).

103. Claim 25 of the '955 patent recites: Two phase coupled inductor of claim 23, the magnetic core further comprising: a first magnetic core having the second planar surface; and a second magnetic core coupled to the first magnetic core, the second magnetic core having the first



planar surface; the first magnetic core and the second magnetic core cooperatively forming the passageway.

104. The Accused Products include a magnetic core further comprising: a first magnetic core having the second planar surface; and a second magnetic core coupled to the first magnetic core, the second magnetic core having the first planar surface; the first magnetic core and the second magnetic core cooperatively forming the passageway. For example, the layout demonstrated at APEC 2019 indicates the magnetic core comprises a first magnetic core having the second planar surface and a second magnetic core coupled to the first magnetic core and having the first planar surface. The first magnetic core and second magnetic core cooperatively form the passageway in the magnetic core.

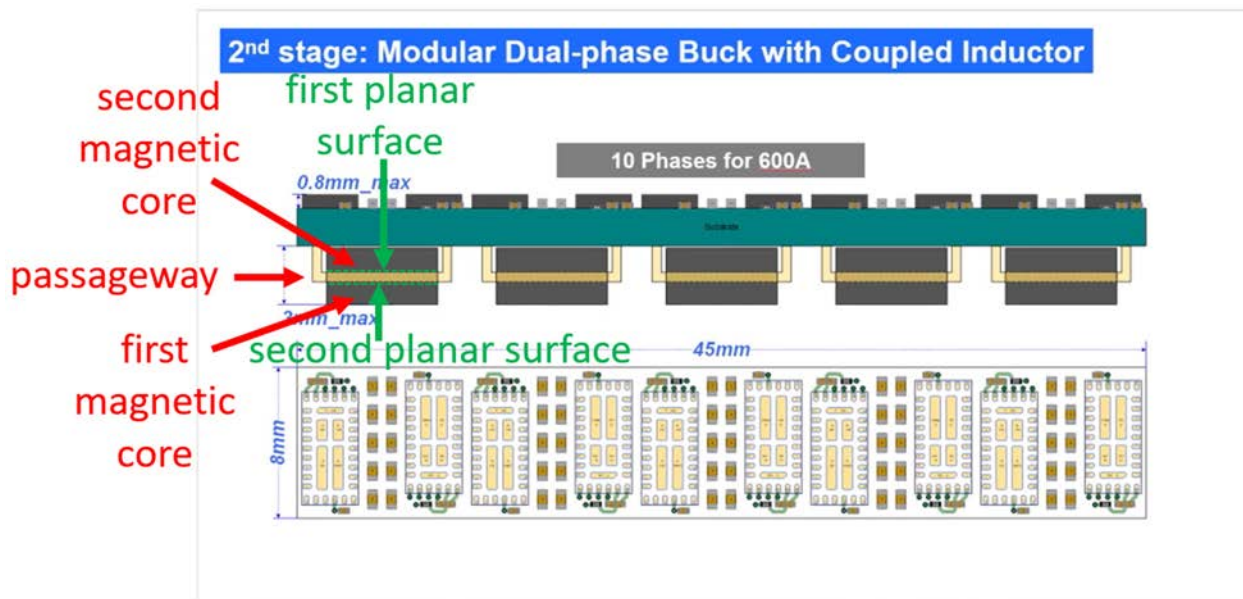

(<https://www.youtube.com/watch?v=w7CmBr1t3Ns> (annotation added)).



105. Claim 26 of the '955 patent recites: two phase coupled inductor of claim 23, at least one of the first winding and the second winding comprising rectangular cross section.

106. The Accused Products include at least one of the first winding and the second winding comprising rectangular cross section. For example, the layout demonstrated at APEC 2019 indicates that the two phase coupled inductors are surface-mounted components, and the use of surface-mounted coupled inductors indicates that the first and second windings of the coupled inductor have flat pads for soldering to the board. A common manufacturing practice to create flat solderable pads for the windings is to use windings with a rectangular cross sections, which allows the flat surface of the winding to be used as a flat soldering pad.

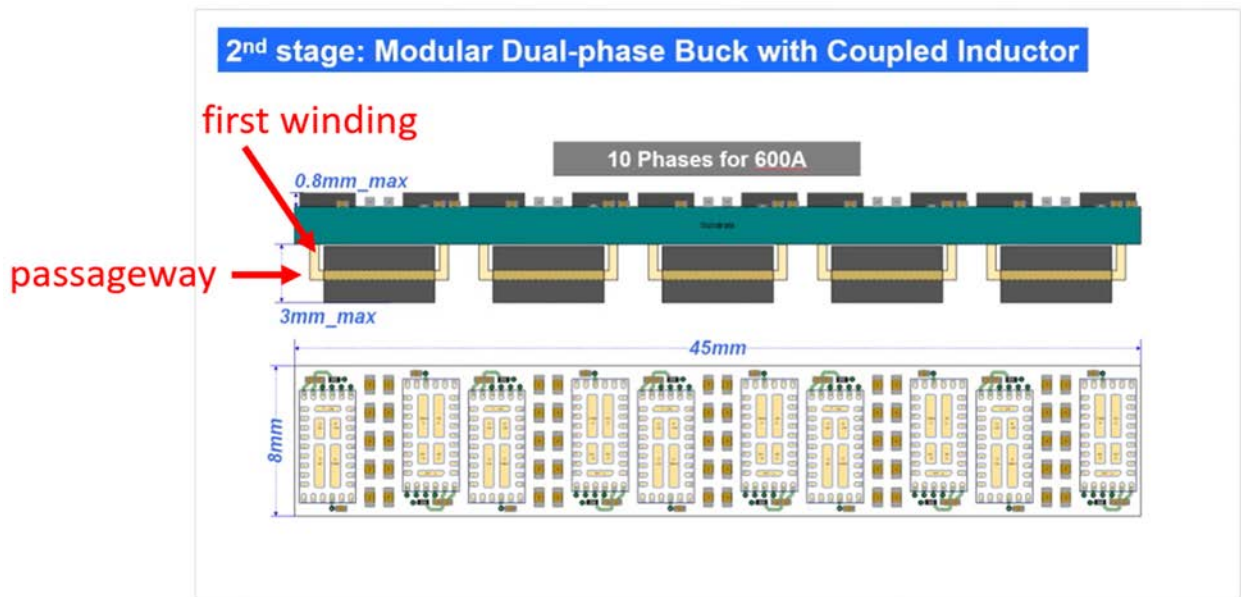

(<https://www.youtube.com/watch?v=w7CmBr1t3Ns> (annotation added)).

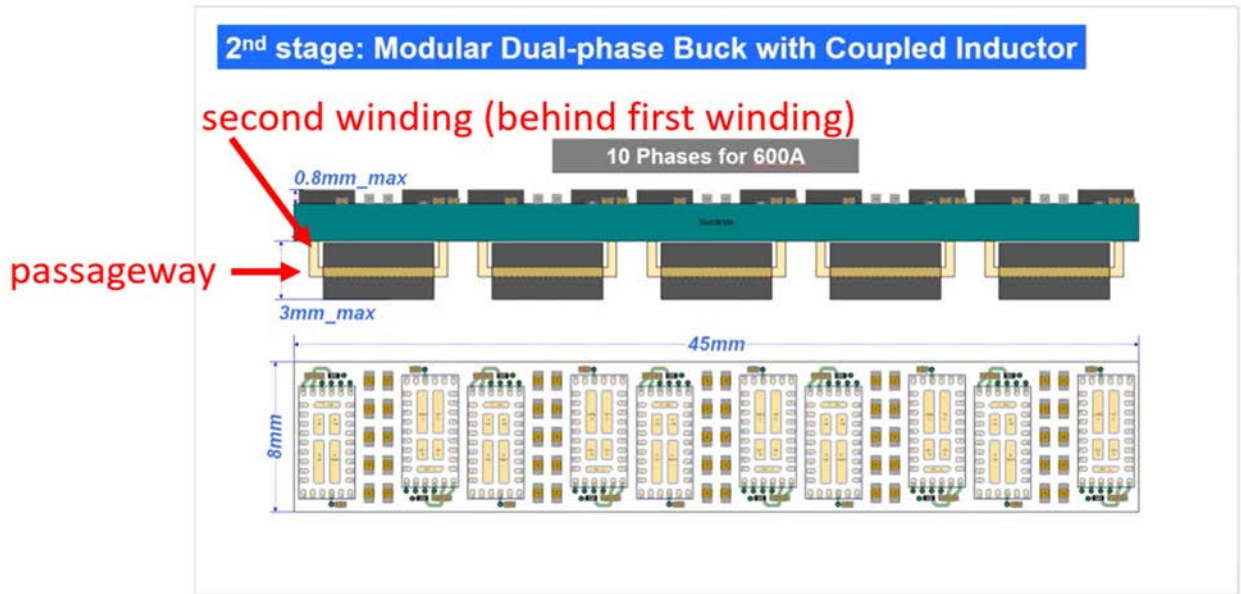

(<https://www.youtube.com/watch?v=w7CmBr1t3Ns> (annotation added)).

107. Claim 27 of the '955 patent recites: Two phase coupled inductor of claim 23, each winding having two ends, and each end forming a solderable tab for connection to a printed circuit board.

108. The Accused Products include each winding having two ends, and each end forming a solderable tab for connection to a printed circuit board. For example, the layout demonstrated at APEC 2019 indicates each winding has two ends with each end forming a solderable tab for connection to a printed circuit board.

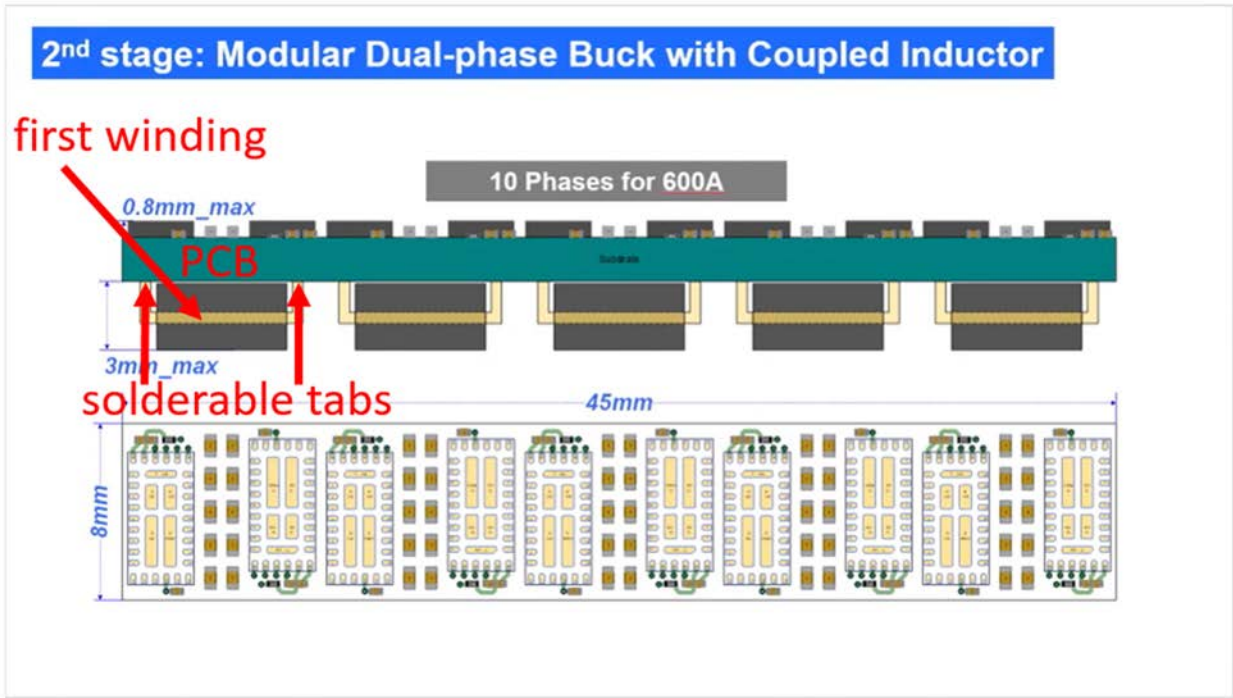

(<https://www.youtube.com/watch?v=w7CmBr1t3Ns> (annotation added)).

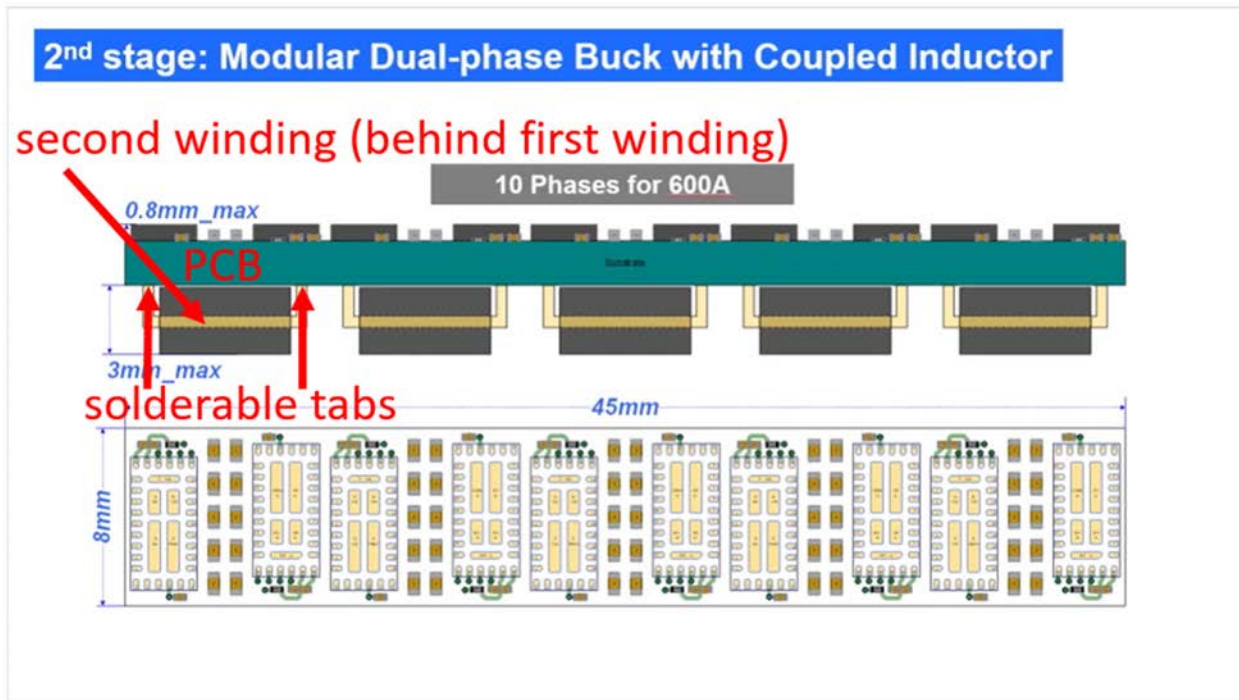

(<https://www.youtube.com/watch?v=w7CmBr1t3Ns> (annotation added)).



109. Claim 28 of the '955 patent recites: Two phase coupled inductor of claim 23, the power converter comprising a two phase DC-to-DC converter that produces an output voltage from an input voltage, the DC-to-DC converter switching a first voltage across the first winding at about 180 degrees out of phase with a second voltage across the second winding to regulate a magnitude of the output voltage, and the first and second voltages being formed from one or a combination of the input and output voltages.

110. The Accused Products are two phase DC-to-DC converters that produce an output voltage from an input voltage, the DC-to-DC converter switching a first voltage across the first winding at about 180 degrees out of phase with a second voltage across the second winding to regulate a magnitude of the output voltage, and the first and second voltages being formed from one or a combination of the input and output voltages. For example, the layout demonstrated at APEC 2019 is titled “Modular *Dual-phase* Buck with *Coupled Inductor*” and “*10 Phases* for 600A,” indicating that each of the five inductors pictured is a 2-phase coupled inductor such that the total amounts to “10 Phases.” Likewise, Monolithic’s demonstration at APEC 2019 discussed an 8-phase power converter, and the video displayed a board with four pairs of control circuits instead of the five pairs shown in the 10-phase layout. The layout and video both show the first control circuit’s physical orientation with respect to the second control circuit, and the physical orientation of the control circuits is further evidence that each coupled inductor is a 2-phase coupled inductor. The use of 2-phase coupled inductors in the layout demonstrated at APEC 2019 is indicative of the DC-to-DC converter switching a first voltage across the first winding at about 180 degrees out of phase with a second voltage across the second winding to regulate a magnitude of the output voltage. The first and second voltages are formed from one or a combination of the input and output voltages. For example, Monolithic demonstrated using a “Dual-phase Buck”



converter to regulate an output voltage of 1 volt from an intermediate input voltage of 5–8 volts at APEC 2019. The layout demonstrated at APEC 2019 indicates the intermediate input voltage is switched across the windings of the 2-phase coupled inductor by connecting one end of each winding to a common 1 volt output voltage and individually switching the other end of each winding between ground and the intermediate 5–8 volt input voltage.

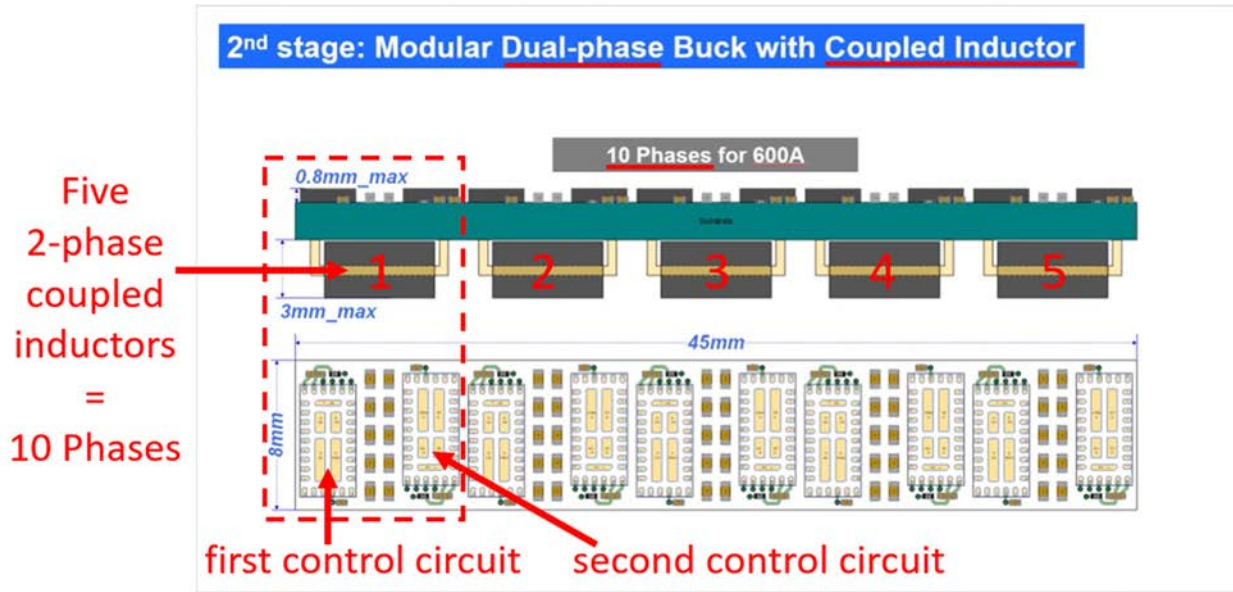

(<https://www.youtube.com/watch?v=w7CmBr1t3Ns> (annotation added)).

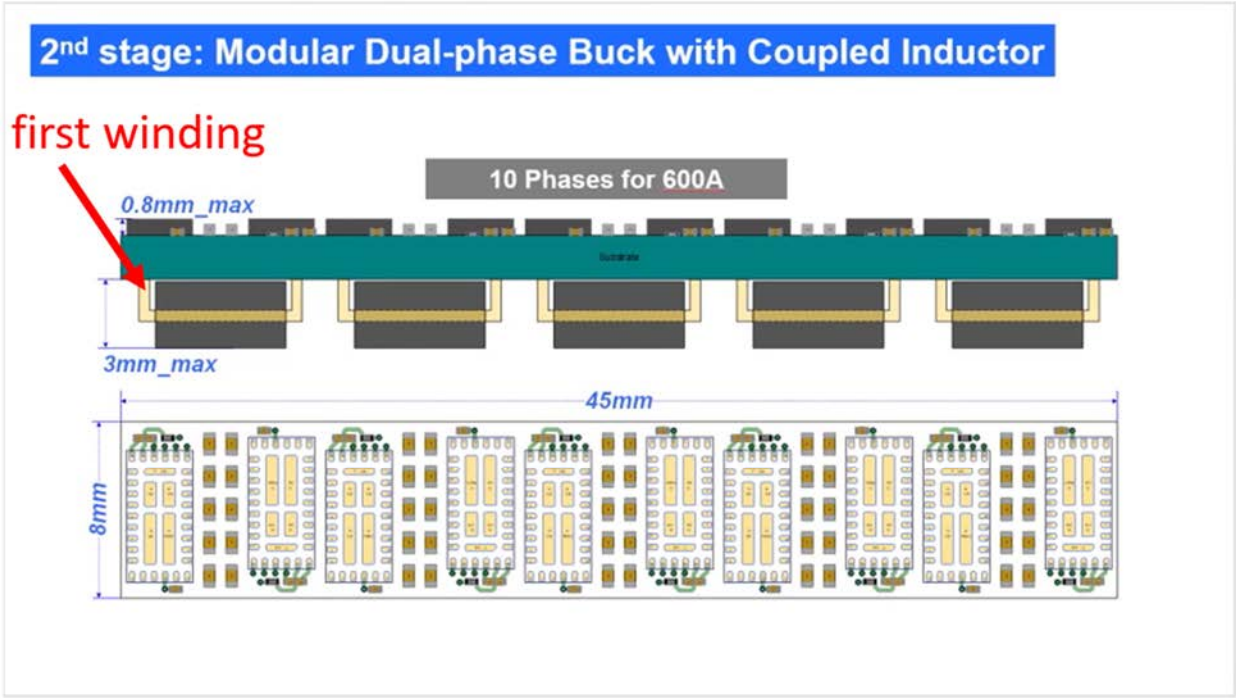

(<https://www.youtube.com/watch?v=w7CmBr1t3Ns> (annotation added)).

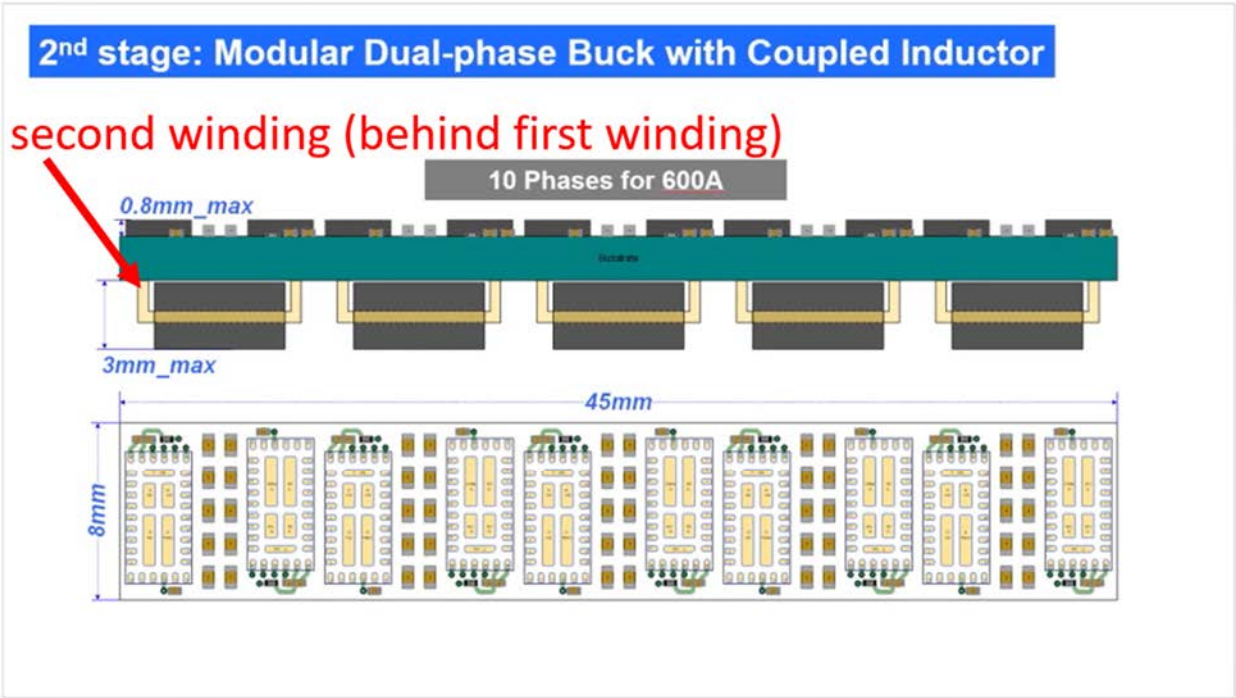

(<https://www.youtube.com/watch?v=w7CmBr1t3Ns> (annotation added)).



48V-1V for CPU or ASIC Power

MPS

400

POWERING CONSUMER APPLICATIONS

48V-1V Power Solution for CPU, SoC or ASIC Controller

Our new 48 volt to 1 volt power solution

APEC 2019 | Telecom Demo by Monolithic Power Systems

294 views • Jul 24, 2019

0 0 SHARE SAVE ...

(<https://www.youtube.com/watch?v=w7CmBr1t3Ns>).

48V-1V for CPU or ASIC Power

MPS

400

POWERING CONSUMER APPLICATIONS

1st stage: 300W Module 3D View

6mm 27mm 18mm

Magnetic Core

Magnetic Core

48V converted down to intermediate voltage: 5V-8V

APEC 2019 | Telecom Demo by Monolithic Power Systems

297 views • Jul 24, 2019

0 0 SHARE SAVE ...



(<https://www.youtube.com/watch?v=w7CmBr1t3Ns>).

111. This description is based on publicly available information and a reasonable investigation of the structure and operation of the Accused Products. Volterra reserves the right to modify this description, including, for example, on the basis of information about the Accused Products that it obtains during discovery.

112. Monolithic's infringement has damaged and continues to damage Volterra in an amount yet to be determined, of at least a reasonable royalty and/or the lost profits that Volterra would have made but for Monolithic's acts of infringement.

113. This is an exceptional case. Volterra is entitled to attorneys' fees and costs under 35 U.S.C. § 285 as a result of the infringement of the '955 patent by Monolithic.

114. Volterra has no adequate remedy at law for Monolithic's infringement. As a direct and proximate result of Monolithic's acts of infringement, Volterra has suffered and continues to suffer damages and irreparable harm. Unless Monolithic's acts of infringement are enjoined by the Court, Volterra will continue to be damaged and irreparably harmed.

PRAYER FOR RELIEF

WHEREFORE, Volterra respectfully requests:

1. That Judgment be entered that Monolithic has infringed one or more of the Asserted Patents, directly and indirectly, by way of inducement or contributory infringement, literally or under the doctrine of equivalents;

2. That, in accordance with 35 U.S.C. § 283, Monolithic and all affiliates, employees, agents, officers, directors, attorneys, successors, and assigns and all those acting on behalf of or in active concert or participation with any of them, be preliminarily and permanently enjoined from (1) infringing the Asserted Patents and (2) making, using, selling, offering for sale and/or importing the Accused Products;



3. An award of damages sufficient to compensate Volterra for Monolithic's infringement under 35 U.S.C. § 284;
4. An accounting to determine the damages to be awarded to Volterra as a result of Monolithic's infringement, including an accounting for infringing sales not presented at trial and an award of additional damages for any such infringing sales;
5. That the case be found exceptional under 35 U.S.C. § 285 and that Volterra be awarded its attorneys' fees;
6. Costs and expenses in this action;
7. An award of prejudgment and post-judgment interest; and
8. Such other and further relief as the Court may deem just and proper.

DEMAND FOR JURY TRIAL

Pursuant to Rule 38(b) of the Federal Rules of Civil Procedure, Volterra respectfully demands a trial by jury on all issues raised by the Complaint.

Dated: September 17, 2020

/s/ Robert M. Oakes
Robert M. Oakes (#5217)
FISH & RICHARDSON P.C.
222 Delaware Avenue, 17th Floor
P.O. Box 1114
Wilmington, DE 19899
Tel: (302) 652-5070
oakes@fr.com

David M. Barkan (admitted *pro hac vice*)
500 Arguello Street, Suite 500
Redwood City, CA 94063
Tel: (650) 839-5070
barkan@fr.com

Attorneys for Plaintiff
VOLTERRA SEMICONDUCTOR LLC