

UNITED STATES DISTRICT COURT
WESTERN DISTRICT OF TEXAS
WACO DIVISION

WSOU INVESTMENTS, LLC D/B/A
BRAZOS LICENSING AND DEVELOPMENT,

Plaintiff,

v.

HEWLETT PACKARD ENTERPRISE COMPANY,

Defendant.

Civil Action No. 6:20-cv-00730-ADA

JURY TRIAL DEMANDED

**BRAZOS'S FIRST AMENDED COMPLAINT AGAINST HPE FOR
INFRINGEMENT OF U.S. PATENT NO. 8,462,774**

Plaintiff WSOU Investments, LLC d/b/a Brazos Licensing and Development (“Brazos”), by and through its attorneys, files this First Amended Complaint for Patent Infringement against defendant Hewlett Packard Enterprise Company (“HPE”) and alleges:

NATURE OF THE ACTION

1. This is a civil action for patent infringement arising under the Patent Laws of the United States, 35 U.S.C. §§ 1 *et seq.*, including §§ 271, 281, 284, and 285.

THE PARTIES

2. Brazos is a limited liability corporation organized and existing under the laws of Delaware, with its principal place of business at 605 Austin Avenue, Suite 6, Waco, Texas 76701.

3. On information and belief, HPE is a corporation organized and existing under the laws of Delaware, with a regular and established place of business located at 14231 Tandem Boulevard, Austin, Texas 78728. HPE may be served through its designated agent for service of process, CT Corporation System, 1999 Bryan Street, Suite 900, Dallas, Texas, 75201.

JURISDICTION AND VENUE

4. This Court has jurisdiction over the subject matter of this action under 28 U.S.C. §§ 1331 and 1338(a).

5. This Court has specific and general personal jurisdiction over HPE pursuant to due process and/or the Texas Long Arm Statute because HPE has committed and continues to commit acts of patent infringement, including acts giving rise to this action within the State of Texas and within this Judicial District. The Court's exercise of jurisdiction over HPE would not offend traditional notions of fair play and substantial justice because HPE has established minimum contacts with the forum. For example, on information and belief, HPE has committed acts of infringement in this Judicial District, directly and/or through intermediaries, by, among other things, making, using, offering to sell, selling, and/or importing products and/or services that infringe the Asserted Patent, as alleged herein.

6. Upon information and belief, HPE has continuous and systematic business contacts with the State of Texas. HPE is registered to do business in the State of Texas, has offices and facilities in the State of Texas, and actively directs its activities to customers located in the State of Texas. HPE, directly and/or through affiliates and/or intermediaries, conducts its business extensively throughout Texas, by shipping, importing, manufacturing, distributing, offering for sale, selling, and/or advertising its products and services in the State of Texas and this Judicial District.

7. Venue is proper in this Court pursuant to 28 U.S.C. § 1400(b). HPE is registered to do business in Texas and, upon information and belief, HPE has offices in this Judicial District, has transacted business in this Judicial District, and has committed acts of direct and indirect infringement in this Judicial District by, among other things, making, using, distributing, installing, configuring, importing, offering to sell, and selling products that infringe the Asserted

Patent. HPE has regular and established places of business in this Judicial District, as set forth below.

8. HPE maintains a regular and established place of business in this Judicial District, at least at 14231 Tandem Boulevard, Austin, Texas 78728:^{1,2}

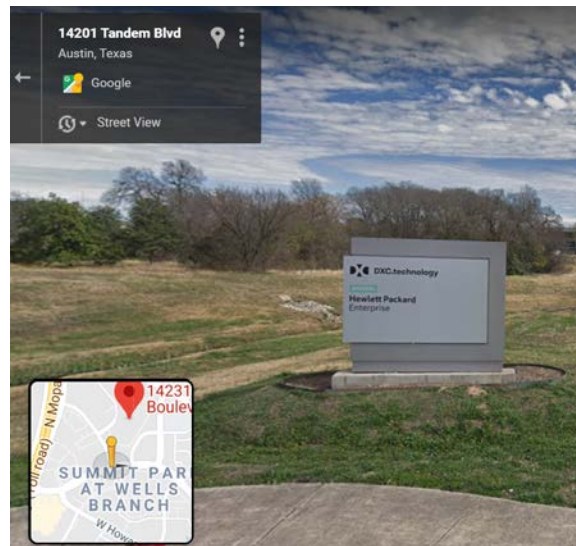

9. Upon information and belief, HPE conducts business and serves customers from its regular and established place of business in Austin, Texas, in this District. Upon information and belief, HPE's Austin office is located on a 52-acre campus.³

10. In October 2019, it was reported that HPE signed a lease for a 27,326-square-foot-space in a 164,714-square-foot office building in North Austin at Paloma Ridge, located at 13620 FM 620 Austin, Texas, 78717.⁴

¹ See <https://www.hpe.com/us/en/contact-hpe.html>.

² See <https://goo.gl/maps/mojArn1WxaHcHU8v8>; see also <https://goo.gl/maps/cBjm1De4gVPFMeam9>.

³ See <https://www2.colliers.com/en/properties/austin-continuum/USA-14231-tandem-boulevard-austin-tx-78728/usa1046778>.

⁴ See <https://communityimpact.com/local-news/austin/leander-cedar-park/coming-soon/2019/10/23/hewlett-packard-signs-lease-at-paloma-ridge-on-fm-620/>.

11. Upon information and belief, HPE owns at least two properties in Austin, Texas, in this Judicial District.⁵

12. HPE maintains regular and established places of business in the State of Texas, nearby to this District, including at 11445 Compaq Center West Drive Houston, Texas, 77070; and 6080 Tennyson Parkway, Suite 400, Plano, Texas 75024.⁶

13. HPE website states that HPE is as “a global edge-to-cloud Platform-as-a-Service company . . . that helps customers connect, protect, analyze, and act on all [of the customer’s] data and applications wherever they live”⁷ Upon information and belief, HPE designs, manufactures, uses, imports into the United States, sells, and/or offers for sale in the United States products that infringe the Asserted Patent, directly and or through intermediaries, as alleged herein. HPE markets, sells, and/or offers to sell its products and/or services, including those accused herein of infringement, to actual and potential customers and end-users located in Texas and in this Judicial District, as alleged herein.

14. HPE organizes its business into “four segments,” as described in its Form 10-K for the fiscal year ended October 31, 2019. One of these “segments” is the “Intelligent Edge” segment, which “provides a portfolio of secure Edge-to-Cloud solutions . . . that include wireless local area network (‘LAN’), campus and data center switching, software-defined wide area networking, security, and associated services to enable secure connectivity for business of any size.” HPE’s “Intelligent Edge” “segment” “operat[es] under the Aruba brand.” HPE reports

⁵ See <http://propaccess.traviscad.org/clientdb/SearchResults.aspx> (printout attached as Exhibit B).

⁶ See *supra* note 1.

⁷ See <https://www.hpe.com/us/en/about.html>.

revenues from the “HPE Aruba Product” and “HPE Aruba Service” business units within the Intelligent Edge segment of its business on its Form 10-K.⁸

15. HPE advertises and sells HPE Aruba Products and HPE Aruba Services to customers, *inter alia*, as part of its Networking portfolio, which is comprised of “AI-powered networking solutions for the Intelligent Edge.”⁹ HPE also promotes and sells HPE Aruba Products and HPE Aruba Services to customers as part of its “HPE OEM integrated solution” or “HPE OEM Solutions” portfolio.¹⁰

16. HPE’s website permits users to configure and customize HPE products, including HPE Aruba Products and HPE Aruba Services, and request price quotes from HPE on the configured products.¹¹ HPE’s website also permits users to purchase HPE products, including HPE Aruba Products, directly from HPE’s website.¹²

17. Upon information and belief, HPE offers trainings and/or certifications to its employees including, *inter alia*, trainings and certifications regarding the sales and/or service of HPE products, including HPE Aruba Products and HPE Aruba Services. For example, HPE offers an HPE Sales Certification to HPE employees, including HPE sales team members, that teaches how to “describe, position and recommend” HPE Aruba Products and HPE Aruba Services to customers.¹³

⁸ See <https://investors.hpe.com/~media/Files/H/HP-Enterprise-IR/documents/hpe-10k2019.pdf>.

⁹ See <https://www.hpe.com/us/en/networking.html>.

¹⁰ See <https://www.hpe.com/us/en/oem.html>.

¹¹ See, e.g., <https://h22174.www2.hpe.com/SimplifiedConfig/Welcome> (printout attached as Exhibit C).

¹² See, e.g., <https://buy.hpe.com/us/en/networking/switches/fixed-port-l3-managed-ethernet-switches/6000-switch-products/aruba-6400-switch-series/p/1012138126>.

¹³ See <https://certification-learning.hpe.com/tr/datacard/Certification/Aruba-SCE-APAS>.

18. As of August 2020, HPE advertised at least fifteen public job postings for positions at HPE's Austin, Texas office.¹⁴ At least one such posting advertised an opening in HPE's Austin office for a Driver Software Engineer, whose responsibilities include, *inter alia*, the ability to “[d]esign, develop, and integrate driver software features and capabilities for HPE's networking product line,”¹⁵ which includes HPE Aruba Products and HPE Aruba Services.¹⁶

COUNT I
(Infringement of U.S. Patent No. 8,462,774)

19. Brazos re-alleges and incorporates by reference the preceding paragraphs 1–18 of this Complaint.

20. On June 11, 2013, the U.S. Patent & Trademark Office duly and legally issued U.S. Patent No. 8,462,774 (the “’774 Patent”), entitled “Virtual IP Interfaces on Multi-Chassis Link Aggregates.” A true and correct copy of the ’774 Patent is attached as Exhibit A to this Complaint.

21. The ’774 Patent is valid, enforceable, and was duly issued in full compliance with Title 35 of the United States Code.

22. Brazos is the owner of all rights, title, and interest in and to the ’774 Patent, including the right to assert all causes of action arising under the ’774 Patent and the right to any remedies for the infringement of the ’774 Patent, including the exclusive right to recover for past infringement.

¹⁴ See <https://www.linkedin.com/jobs/search?keywords=Hewlett%20Packard%20Enterprise&location=Austin%2C%20Texas%2C%20United%20States> (printout attached as Exhibit D).

¹⁵ See <https://www.linkedin.com/jobs/view/driver-software-engineer-at-hewlett-packard-enterprise-1901505190/>.

¹⁶ See *supra* note 9.

23. The Accused Products that infringe at least one claim of the '774 Patent include but are not limited to HPE's switches with Multi-Chassis Link Aggregation Group ("MC-LAG") functionality, which is also known as VSX LAG, including, but not limited to, HPE Aruba 6400,¹⁷ 8320,¹⁸ 8325,¹⁹ and 8400²⁰ series switches (collectively, the "Accused Products").²¹

24. HPE makes, uses, sells, offers for sale, imports, and/or distributes the Accused Products in the United States, including within this Judicial District.

25. The Accused Products include "HPE Aruba Products" and/or "HPE Aruba Services" as described in HPE's Form 10-K for the fiscal year ended October 31, 2019.²²

¹⁷ See <https://buy.hpe.com/us/en/networking/switches/fixed-port-l3-managed-ethernet-switches/6000-switch-products/aruba-6400-switch-series/p/1012138126>; <https://www.arubanetworks.com/products/networking/switches/6400-series/>; see also https://support.hpe.com/hpesc/public/docDisplay?docId=emr_na-a00092375en_us.

¹⁸ See <https://buy.hpe.com/us/en/networking/switches/fixed-port-l3-managed-ethernet-switches/aruba-8300-switch-products/aruba-8320-switch-series/p/1010323113>; <https://www.arubanetworks.com/products/networking/switches/8320-series/>; see also https://support.hpe.com/hpesc/public/docDisplay?docId=a00037826en_us.

¹⁹ See <https://buy.hpe.com/us/en/networking/switches/fixed-port-l3-managed-ethernet-switches/aruba-8325-switch-products/aruba-8325-switch-series/p/1011156780>; <https://www.arubanetworks.com/products/networking/switches/8325-series/>; see also https://support.hpe.com/hpesc/public/docDisplay?docId=emr_na-a00065466en_us.

²⁰ See <https://buy.hpe.com/us/en/networking/switches/modular-ethernet-switches/aruba-8400-switch-products/aruba-8400-switch-series/p/1010129959>; <https://www.arubanetworks.com/products/networking/switches/8400-series/>; see also https://techhub.hpe.com/eginfolib/Aruba/OS-CX_10.03/5200-5958/index.html#GUID-A100D19F-3FC6-49DD-B63B-90A18C0FA1EF.html.

²¹ See <https://buy.hpe.com/us/en/networking/switches/fixed-port-l3-managed-ethernet-switches/6000-switch-products/aruba-6400-switch-series/p/1012138126>; <https://buy.hpe.com/us/en/networking/switches/fixed-port-l3-managed-ethernet-switches/aruba-8300-switch-products/aruba-8320-switch-series/p/1010323113>; <https://buy.hpe.com/us/en/networking/switches/fixed-port-l3-managed-ethernet-switches/aruba-8325-switch-products/aruba-8325-switch-series/p/1011156780>; <https://buy.hpe.com/us/en/networking/switches/modular-ethernet-switches/aruba-8400-switch-products/aruba-8400-switch-series/p/1010129959>; see also *supra* note 9.

²² See *supra* note 8.

26. Brazos will identify additional accused products pursuant to the Court's scheduling order.

27. The Accused Products are configured to perform each element of and infringe at least the exemplary claim 12 of the '774 Patent, which recites:

A method for configuring a virtual Internet Protocol (IP) interface on a local aggregation switch of a multi-chassis system, comprising:

coupling a portion of local customer-facing ports of the local aggregation switch to a multi-chassis link aggregation group (MC-LAG), the MC-LAG being further coupled to a portion of remote customer-facing ports of a remote aggregation switch of the multi-chassis system, the local aggregation switch and the remote aggregation switch each being active and in a separate respective physical chassis;

assigning the MC-LAG to a multi-chassis link aggregate group virtual local area network (MC-LAG VLAN);

allocating a virtual Internet Protocol (IP) interface to the MC-LAG VLAN; and

configuring the virtual IP interface on the local aggregation switch with an IP address.

28. The Accused Products are configured to practice a method for configuring a virtual Internet Protocol ("IP") interface on a local aggregation switch of a multi-chassis system.

29. The Accused Products are configured to implement MC-LAG to improve network reliability by using two physical switches instead of one, so that even if one of the physical node fails, the network can continue without interruption. The two switches each use virtual IP interfaces and present themselves as a single virtual switch to the rest of the network.

30. "Aruba Virtual Switching Extension (VSX) is virtualization technology for aggregation/core switches running the ArubaOS-CX operating system. This solution lets the switches present as one virtualized switch in critical areas. . . . Since the solution is primarily for

high availability, it is expected that most of the configuration policy is the same across both peers.”²³

31. The figure (hereinafter Figure A) below provides a “[s]ample VSX topology.”²⁴

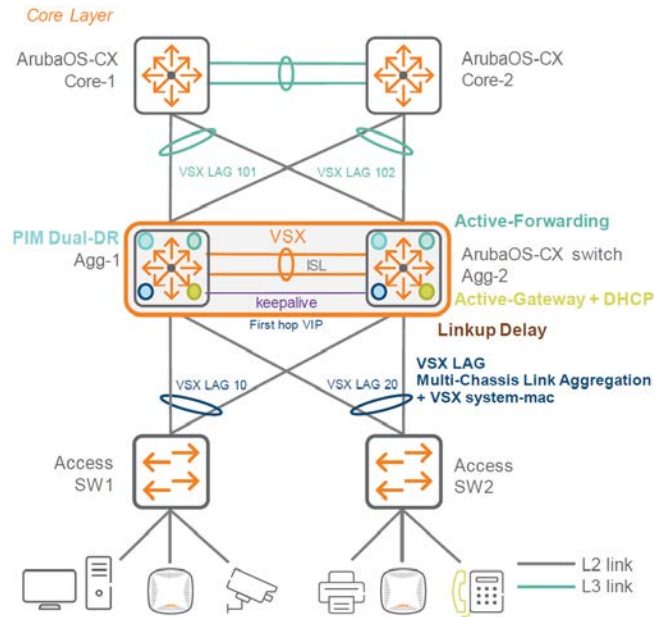

Figure A

²³ See *supra* https://support.hpe.com/hpsc/public/docDisplay?docId=a00091706en_us at 12.

²⁴ See *supra* note 23 at 14 (Fig. 1).

32. The figure below (hereinafter, Figure B) “illustrates a scenario in which both VSX switches are up, but the ISL link is down” and “[t]he switches cannot exchange information.”

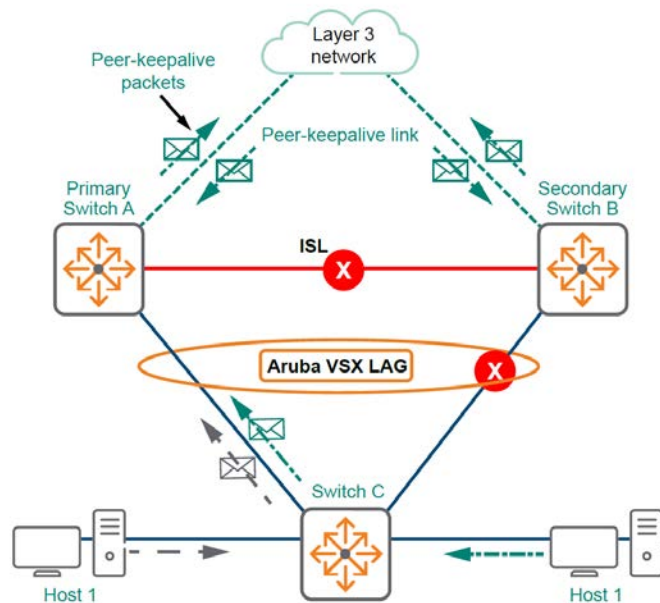

Figure B

“The keepalive functionality brings down the link between Switch B and Switch C The traffic is forced to go from Switch C to Switch A and then through the Layer 3 network to access Switch B. The keepalive path is over the Layer 3 network. Traffic traveling from Switch B to Switch A is also forced to go through the Layer 3 network.”²⁵

33. The method that the Accused Products are configured to perform comprises coupling a portion of local customer-facing ports of the local aggregation switch to a MC-LAG, the MC-LAG being further coupled to a portion of remote customer-facing ports of a remote aggregation switch of the multi-chassis system, the local aggregation switch and the remote aggregation switch each being active and in a separate respective physical chassis.

²⁵ See *supra* note 23 at 53–54.

34. MC-LAG, as implemented by the Accused Products, uses two aggregation switches that are in different physical chassis. The MC-LAG uses some of the ports from a primary switch (“aggregate 1” or “Agg-1”) and some of the ports from a secondary switch (“aggregate 2” or “Agg-2”) to make a virtual switch that appears as a single switch to the rest of the network. Each MC-LAG can have up to four ports from each switch. The primary switch is “local” relative to its “remote” secondary switch peer.

35. The figure below (hereinafter Figure C) illustrates a “VSX LAG[] span[ning] two switches and operat[ing] in active-active mode.”

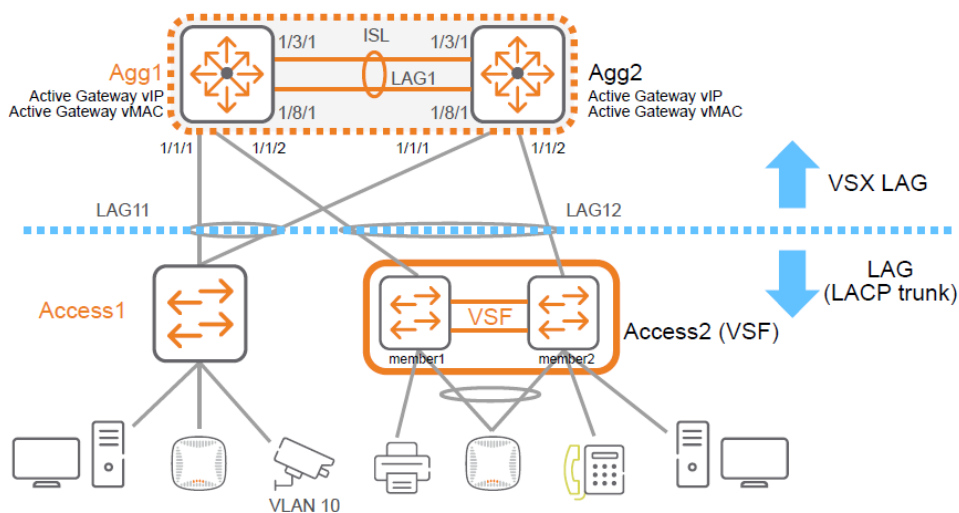

Figure C

“Traffic between the access layer and aggregation layer switches can be forwarded to any of the active links. There are not loops and no need for spanning tree protocol or blocked ports.”²⁶

36. As shown, for example, in Figure C, two switches (Agg1 and Agg2) each contribute their respective ports numbered 1/1/1 (each switch has its own port number 1/1/1) to LAG11 connected to Access1, and their ports numbered 1/1/2 to LAG12 connected to Access2. The two switches also contribute their ports 1/3/1 and 1/8/1 to LAG1, which is the Inter-Switch

²⁶ See *supra* note 23 at 57–58.

Link (“ISL”) that connects the switches to each other. Ports such as 1/1/1 and 1/1/2 are customer-facing because they connect to customer equipment and LANs, such as VLAN 10. Both switches are active (“active-active mode”) in the normal configuration.

37. “A VSX LAG supports a maximum of four member links per switch segment. . . . VSX synchronization syncs from the primary switch (aggregate 1) to the secondary switch (aggregate-2).”²⁷

38. The instructions below for “[a]dding a physical interface into the LAG” show LAG 128 coupled to ports (physical interface) 1/4/28 and 1/4/32).²⁸

```
switch (config) # interface 1/4/28
switch (config-if) # no shutdown
switch (config-if) # lag 128
switch (config) # interface 1/4/32
switch (config-if) # no shutdown
switch (config-if) # lag 128
```

39. The method that the Accused Products are configured to perform comprises assigning the MC-LAG to a multi-chassis link aggregate group virtual local area network (MC-LAG VLAN).

40. Each MC-LAG, as implemented by the Accused Products, is assigned to up to 10,000 virtual local area networks (VLANs).

²⁷ See *supra* note 23 at 25.

²⁸ See *supra* note 23 at 26.

41. The figure below (hereinafter Figure D) illustrates a “[s]ample virtual active gateway configuration” using MC-LAG as implemented by the Accused Products.”²⁹

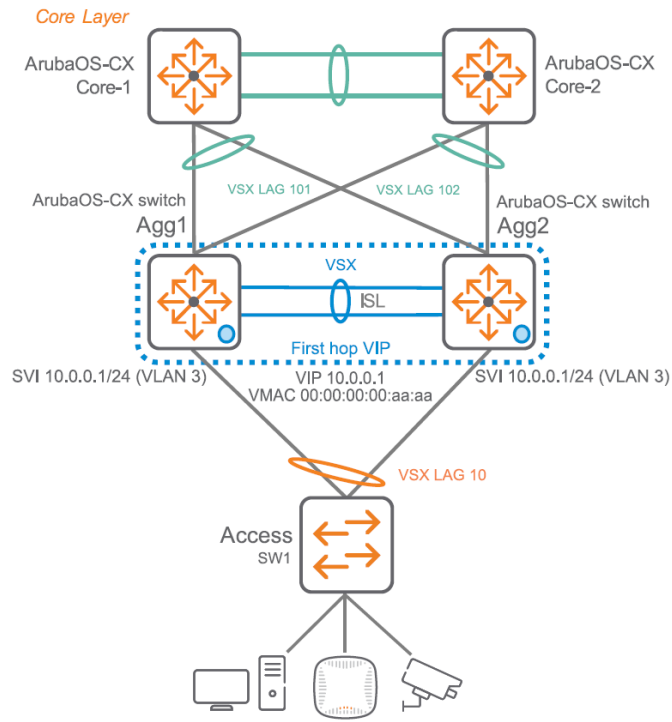

Figure D

In this figure, VSX LAG 10 is assigned to VLAN 3.

²⁹ See *supra* note 23 at 66 (Fig. 8).

42. The figure below (hereinafter Figure E) illustrates an “ECMP and VSX LAG configuration,” which “is the preferred configuration because LAGs introduce simplicity by reducing the number of transit VLANs and SVIs.”³⁰

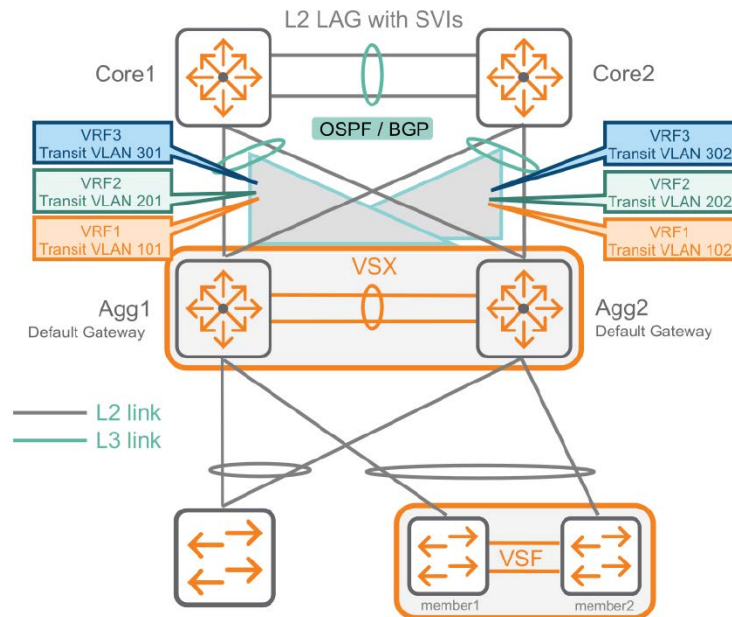

Figure E

In this figure, the MC-LAG is assigned VLANs 100-104 (orange), 200-204 (green), and 300-304 (blue).

43. With MC-LAG as implemented by the Accused Products, “[t]he total number of VLANs across ports is (ports x VLANs) = 4094 ports per VLAN. Loop protect can be configured on a maximum of 4094 VLANs across all interfaces without updating CoPP policies for loop protect. . . . You can assign a maximum of 10,000 VLANs across all the interfaces.”

44. The method that the Accused Products are configured to perform comprises allocating a virtual IP interface to the MC-LAG VLAN.

45. MC-LAGs as implemented by the Accused Products are allocated a virtual IP address to use for communicating with their MC-LAG switches.

³⁰ See *supra* note 23 at 104–05 (Fig. 19)

46. The figure below (hereinafter Figure F) illustrates MC-LAG as implemented by the Accused Products in the “use case of active/standby firewall with active gateway as the next-hop router.”³¹

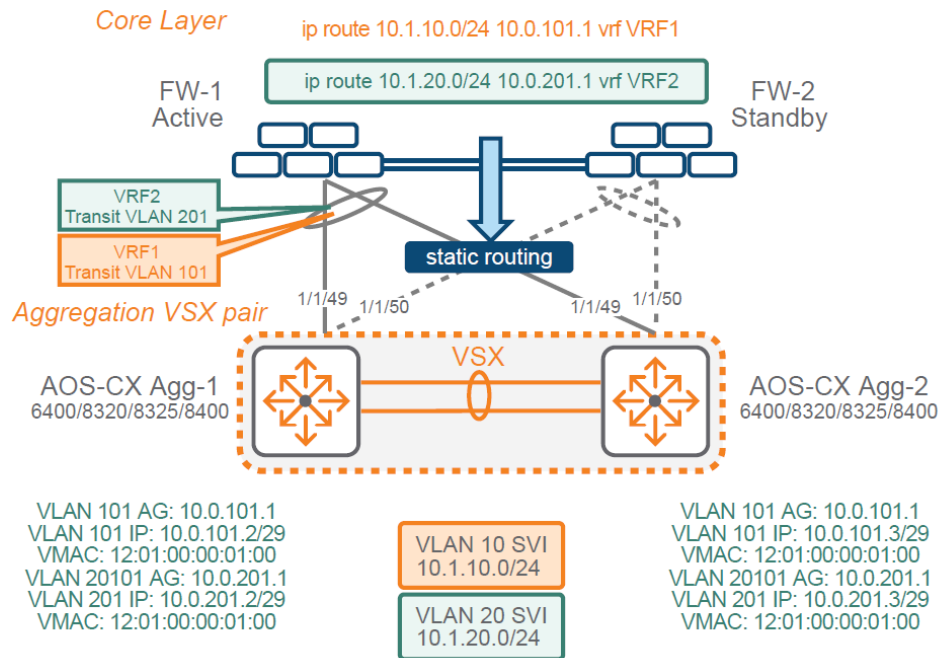

Figure F

47. The figure below (hereinafter Figure G) illustrates how to configure the Accused Products to allocate a virtual Internet Protocol (IP) interface to the LC-LAG VLAN.³²

Active gateway configurations

Task	Command	Example
Configuring a virtual IPv4 and IPv6 address for an interface VLAN.	active-gateway {ip ipv6} [<IP-ADDRESS>] [mac <MAC-ADDRESS>]	<pre> switch(config)# vlan 2 switch(config)# interface vlan 2 switch(config-if-vlan)# ip address 10.0.0.1/24 switch(config-if-vlan)# active-gateway ip 10.0.0.2 mac 00:00:00:00:00:01 switch(config-if-vlan)# ipv6 address aa:bb::cc:dd/24 switch(config-if-vlan)# active-gateway ipv6 2001:DB8::/32 mac 00:00:00:01:00:01 </pre>

Figure G

³¹ See *supra* note 23 at 108 (Fig. 22).

³² See *supra* note 23 at 62.

48. The method that the Accused Products are configured to perform comprises configuring the virtual IP interface on the local aggregation switch with an IP address.

49. The Accused Products are configured to configure the MC-LAG virtual IP interface (which has multiple physical ports) on each aggregation switch (such as Agg1, which is “local” from its perspective compared to its “remote” peer Agg2) with an IP address so that the rest of the network can communicate with the MC-LAG. Each switch can have a different virtual IP address for each -MC-LAG. As shown, for example, in Figure D, the Accused Products allow providing the identical Virtual IP address (“VIP”) to both switches, such as VIP 10.0.0.1 for both Agg1 and Agg2. “VSX aggregation switches can be configured with a shared virtual IP (VIP) and a shared virtual MAC address (VMAC) on the layer 3 VLAN interface. The VIP/VMAC serves as the default gateway for the access layer. The two switches then share the router MAC and function as an active-active gateway for the IP subnet. The first VSX device that receives traffic from the access layer (based on the hashing algorithm over the LAG interface) routes is across to the other subnets.”³³

50. In view of preceding paragraphs 27–49, the Accused Products are configured to practice each and every element of at least claim 12 of the ’774 Patent.

51. HPE, has infringed, and continues to directly infringe, at least one claim of the ’774 Patent, literally or under the doctrine of equivalents, by making, using, selling, offering for sale, importing, and/or distributing the Accused Products in the United States, including within this Judicial District, without the authority of Brazos. HPE’s infringing use of the Accused Products includes its internal use and testing of the Accused Products. HPE’s infringing use of

³³ See *supra* note 23 at 58.

the Accused Products includes its internal use, testing, demonstration and/or configuration of the Accused Products.

52. Upon information and belief, each and every element of at least claim 12 of the '774 Patent is practiced or performed by HPE at least through HPE's internal use and configuration of its own Accused Products, and/or through HPE's testing of the Accused Products, and/or through HPE's providing services for the Accused Products, including but not limited to providing installation, deployment, support, demonstrations, and configuration of the Accused Products.

53. For example, upon information and belief, as part of HPE's business, HPE offers, for a fee, training and certification programs to its employees, customers, and partners that teach how to use and/or implement the Accused Products. Upon information and belief, HPE, while teaching others how to use and/or implement the Accused Products, performs demonstrations, and in so doing, practices each and every element of at least claim 12 of the '774 Patent.

54. As of the date of service of the initial complaint, August 18, 2020, HPE has had actual or constructive knowledge of the '774 Patent and has been on notice of its infringement of the '774 Patent and how the Accused Products infringe the '774 Patent. Notwithstanding this knowledge and notice, since at least that time, HPE has continued to infringe the '774 Patent, by making, using, selling, offering for sale, importing, and/or distributing the Accused Products in the United States.³⁴

³⁴ HPE filed a motion to dismiss that is mooted by this amended complaint. The Federal Circuit and this Court have recognized that post-suit knowledge is sufficient to state a claim for indirect infringement. *See In re Bill of Lading Transmission & Processing Sys. Patent Litig.*, 681 F.3d 1323, 1334-46 (Fed. Cir. 2012) (finding that district court erred in dismissing indirect infringement claims that alleged defendant had actual knowledge of asserted patent "at the latest . . . when [defendant] was served with the complaint"); *see also Frac Shack Inc. v. AFD Petroleum (Texas) Inc.*, 2019 WL 3818048, at *2 (W.D. Tex., 2019) (Albright, J.) (denying

55. Since the date of service of the initial complaint, through its actions, HPE, with knowledge of the '774 Patent, has actively and knowingly induced customers, product makers, distributors, retailers, and/or end users of the Accused Products to directly infringe one or more claims of the '774 Patent throughout the United States, including within this Judicial District. The Accused Products, as provided to HPE's customers and end-users and used as intended and instructed, infringe the '774 Patent. HPE was and is aware that the normal and customary use by end users of the Accused Products infringes the '774 Patent. Upon information and belief, HPE's customers and end-users have used and continue to use the Accused Products in the United States in this manner and directly infringe the '774 Patent. Despite HPE's knowledge of the '774 Patent and knowledge and/or willful blindness that its actions induce infringement by customers and/or end-users, HPE has made, sold, and/or offered for sale the Accused Products, and is continuing to do so, with the specific intent to actively encourage customers and/or end-users to make, use, sell, offer for sale and/or import one or more Accused Products in a manner that HPE knows to be infringing.

56. Moreover, HPE has taken and continues to take active steps to induce infringement of at least claim 12 of the '774 Patent, knowing that those steps will induce, encourage, and facilitate direct infringement by customers, product makers, distributors, retailers, and/or end users. On information and belief, HPE directs, controls, and/or encourages customers' and/or end-users' performance of the claimed steps by taking active steps that include, but are not limited to: making, using, configuring, and selling the Accused Products;

motion to dismiss claims of indirect infringement that alleged defendant had knowledge of how the accused product infringes the asserted patent "from at least service of the Original Complaint," and despite such knowledge, continues to infringe the asserted patent); *Meetrix IP, LLC v. Cisco Systems, Inc.*, 2018 WL 8261315, at *3 (W.D. Tex., 2018) (denying motion to dismiss post-suit indirect infringement claims).

instructing end-users to use the Accused Products; creating and disseminating advertising and promotional materials that encourage the use of the Accused Products, including product descriptions, operating manuals, configuration guides, support materials, technical materials, and other instructions on how to implement and configure the Accused Products; and providing training and certification programs that teach and demonstrate how to use and/or implement the Accused Products. HPE has known that such activities induce end-users to infringe at least claim 12 of the '774 Patent since the date of service of the initial complaint.

57. Examples of HPE's manuals, instructional and support materials, and/or configuration guides for the Accused Products, provided by HPE on its website, that teach and instruct end-users to use and/or configure the Accused Products in ways that practice the claimed invention, include but are not limited to:

- <https://support.hpe.com/hpesc/public/km/search#q=mc-lag>;
- <https://support.hpe.com/hpesc/public/km/search#q=vsx>; and
- https://support.hpe.com/hpesc/public/docDisplay?docId=a00091706en_us.

58. HPE's inducement is ongoing. HPE has continued to induce direct infringement by others, including by instructing end-users regarding the operation and use of the Accused Products in ways that practice the claimed invention, even after being put on actual notice of the infringement of the '774 Patent.

59. Since the date of service of the initial complaint, through its actions, HPE has contributed to, and is contributing to, the infringement of the '774 Patent by having others sell, offer for sale, or use the Accused Products throughout the United States, including within this Judicial District, with knowledge that the Accused Products infringe the '774 Patent. HPE has made and/or sold the Accused Products with knowledge that they have special features that are especially made or adapted for infringing the '774 Patent and are not staple articles of commerce

suitable for substantial non-infringing use. For example, in view of the preceding paragraphs, the Accused Products contain functionality which is material to at least claim 12 of the '774 Patent.

60. The special features include using Multi-Chassis Link Aggregation Group (MC-LAG) functionality, which is also known as VSX LAG, to improve network reliability, which is used in a manner that infringes the '774 Patent.

61. The special features constitute a material part of the invention of one or more claims of the '774 Patent and are not staples articles of commerce suitable for substantial non-infringing use. The Accused Products have no substantial non-infringing uses.

62. Brazos has suffered damages as a result of HPE's direct and indirect infringement of the '774 Patent in an amount adequate to compensate for HPE's infringement, but in no event less than a reasonable royalty for the use made of the invention by HPE, together with interest and costs as fixed by the Court.

JURY DEMAND

Brazos hereby demands a jury on all issues so triable.

PRAYER FOR RELIEF

WHEREFORE, Brazos respectfully requests that the Court:

(a) enter judgment that HPE infringes one or more claims of the '774 Patent literally and/or under the doctrine of equivalents;

(b) enter judgment that HPE has induced infringement and continues to induce infringement of one or more claims of the '774 Patent;

(c) enter judgment that HPE has contributed to and continues to contribute to the infringement of one or more claims of the '774 Patent;

(d) award Brazos damages, to be paid by HPE in an amount adequate to compensate Brazos for such damages, together with pre-judgment and post-judgment interest for the

infringement by HPE of the '774 Patent through the date such judgment is entered in accordance with 35 U.S.C. § 284, and increase such award by up to three times the amount found or assessed in accordance with 35 U.S.C. § 284;

(e) declare this case exceptional pursuant to 35 U.S.C. § 285; and

(f) award Brazos its costs, disbursements, attorneys' fees, and such further and additional relief as is deemed appropriate by this Court.

Respectfully submitted,

Dated: November 6, 2020

Edward J. Naughton
(*pro hac vice*)
enaughton@brownrudnick.com
Rebecca MacDowell Lecaroz
(*pro hac vice*)
rlecaroz@brownrudnick.com
BROWN RUDNICK LLP
One Financial Center
Boston, Massachusetts 02111
telephone: (617) 856-8200
facsimile: (617) 856-8201

Alessandra C. Messing
(*pro hac vice*)
amessing@brownrudnick.com
Timothy J. Rousseau
(*pro hac vice*)
trousseau@brownrudnick.com
Yarelyn Mena
(*pro hac vice*)
ymena@brownrudnick.com
BROWN RUDNICK LLP
7 Times Square
New York, New York 10036
telephone: (212) 209-4800
facsimile: (212) 209-4801

David M. Stein
Texas State Bar No. 797494
dstein@brownrudnick.com
Sarah G. Hartman
California State Bar No. 281751
shartman@brownrudnick.com
BROWN RUDNICK LLP
2211 Michelson Drive, 7th Floor
Irvine, California 92612
telephone: (949) 752-7100
facsimile: (949) 252-1514

/s/ Raymond W. Mort, III

Raymond W. Mort, III
raymort@austinlaw.com
THE MORT LAW FIRM, PLLC
100 Congress Avenue, Suite 2000
Austin, Texas 78701
telephone: (512) 677-6825
facsimile:

Counsel for Plaintiff
WSOU Investments, LLC d/b/a
Brazos Licensing and Development