

**IN THE UNITED STATES DISTRICT COURT  
FOR THE EASTERN DISTRICT OF TEXAS  
MARSHALL DIVISION**

**ERICSSON INC. AND  
TELEFONAKTIEBOLAGET LM ERICSSON,**

**Plaintiffs,**

**v.**

**SAMSUNG ELECTRONICS CO., LTD.,  
SAMSUNG ELECTRONICS AMERICA, INC.,  
AND SAMSUNG RESEARCH AMERICA,**

**Defendants.**

**Civil Action No. 2:20-cv-00380-JRG**

**FIRST AMENDED COMPLAINT**

Plaintiffs Ericsson Inc. and Telefonaktiebolaget LM Ericsson (“Ericsson” is used herein to collectively refer to Telefonaktiebolaget LM Ericsson and/or Ericsson Inc.) file this Complaint against Samsung Electronics Co., Ltd., Samsung Electronics America, Inc., and Samsung Research America (“Samsung” is used herein to collectively refer to Samsung Electronics Co., Ltd., Samsung Electronics America, Inc., and/or Samsung Research America) and hereby allege as follows:

**NATURE OF ACTION**

1. For more than four decades, Ericsson has pioneered the development of the modern cellular network. Ericsson develops infrastructure equipment that makes up the backbone of modern networks; that is, the base stations and cell tower equipment that mobile phones communicate with. Major mobile network operators all over the world buy solutions and/or services from Ericsson, and Ericsson manages networks that serve more than one billion

subscribers globally. Ericsson's equipment is found in more than one hundred and eighty countries.

2. Ericsson is widely viewed as one of the leading innovators in the field of cellular communications. Due to the work of more than twenty-five thousand Ericsson research and development (R&D) employees, Ericsson's inventions are a valuable part of the fundamental technology that connects phones, smartphones, and other mobile devices seamlessly using cellular networks worldwide and provides increased performance and new features for the benefit of consumers. As a result of its extensive research and development efforts, Ericsson has been awarded more than fifty-four thousand patents worldwide. Many of Ericsson's patents are essential to the 2G (GSM, GPRS, and EDGE), 3G (UMTS/WCDMA and HSPA), 4G (LTE, LTE-Advanced, and LTE-Advanced Pro) and/or 5G (NR, New Radio) telecommunications standards, which are used by Samsung's products. Ericsson's infrastructure products likewise utilize these standards.

3. Ericsson has voluntarily and publicly committed that it is prepared to grant licenses under its portfolio of patents that are essential to practice the 2G, 3G, 4G, and/or 5G standards (Essential Patents) on fair, reasonable, and non-discriminatory (FRAND) terms. Ericsson's FRAND commitment is set forth in its intellectual property right (IPR) licensing declarations to the European Telecommunications Standards Institute (ETSI) in accordance with ETSI's IPR Policy. Ericsson's commitment is subject to reciprocity—Ericsson can, and does, insist on a reciprocal license to a potential licensee's Essential Patents to cover Ericsson's cellular equipment. Consistent with its FRAND commitment, Ericsson has widely licensed its portfolio of Essential Patents in over one hundred agreements with members of the telecommunications industry who have agreed to pay royalties to Ericsson for a global portfolio

license. Ericsson reinvests much of the licensing revenue it receives under these global agreements into inventing future generations of standardized telecommunication technologies, spending nearly five billion dollars annually on research and development.

4. The popularity and proliferation of cellular smartphones, tablets, watches, and other connected devices is based on the development of the 2G, 3G, and especially the 4G, and now 5G, communication standards. Without 4G and 5G technology and Ericsson's inventions incorporated therein, smartphones and other mobile devices would not be able to provide the constant on-the-go access to video, streaming media, and gaming that consumers expect today. Furthermore, the widespread adoption of large screen smartphones, tablets, and corresponding applications are dependent on the performance that 4G and 5G technology—and Ericsson's inventions—provide.

5. Samsung is the largest smartphone manufacturer in the world, and also manufactures cellular network infrastructure equipment. Samsung is also involved in standardization, and through its own research and development efforts, has a portfolio of patents that it contends are essential to the 2G, 3G, 4G, and 5G communications standards. Samsung, like Ericsson, has committed that it is prepared to grant licenses under its Essential Patents on FRAND terms. Samsung's FRAND commitment is set forth in its IPR licensing declarations to ETSI in accordance with ETSI's IPR Policy.

6. Samsung and Ericsson have in the past executed global cross-licenses, covering both parties' patents related to the 2G, 3G, and/or 4G cellular standards. Most recently, Samsung and Ericsson executed a multi-year agreement in January 2014. In February 2019, in advance of the expiration of the existing cross-license, Ericsson took steps to initiate negotiations with Samsung towards a new license.

7. To renew the existing license upon expiration, Ericsson proposed a global cross-license, with Samsung taking a license to Ericsson's Essential Patents and with Ericsson taking a license to Samsung's Essential Patents. Both Samsung and Ericsson understood that Samsung would owe Ericsson a substantial balancing payment as part of the cross-license. Ericsson made a cross-license offer under which Samsung would make a balancing payment consistent with the value of Ericsson's Essential Patents as compared to Samsung's. All of the terms of Ericsson's offer, including the balancing payment component, were consistent with Ericsson's FRAND obligation. Samsung did not accept Ericsson's offer, and provided a counteroffer that evidenced Samsung was not negotiating in good faith towards a cross-license on FRAND terms. Instead, Samsung insisted it would only be willing to a cross-license if Ericsson agreed to accept a royalty for Ericsson's Essential Patents significantly below FRAND rates. By insisting Ericsson accept a balancing payment in a global cross-license substantially less than the value of Ericsson's Essential Patents, and less than FRAND, Samsung violated its FRAND commitment by effectively depriving Ericsson of its right to a reciprocal license to Samsung's Essential Patents on FRAND terms. At this point, it is clear that Samsung is not willing or committed to negotiating a global cross-license on FRAND terms and conditions.

8. Samsung's FRAND commitment is a contract between Samsung and ETSI, and Ericsson has the right to enforce it as a third-party beneficiary. In addition, when Samsung commenced negotiations with Ericsson, it was obligated under French law, which governs the FRAND commitment, to negotiate in good faith with Ericsson, yet Samsung has failed to do so. Ericsson has filed this suit against Samsung to remedy these breaches and to invoke the assistance of this Court to enforce its patent rights. Ericsson also seeks a declaration that it has complied with its FRAND commitment, and that Samsung has not.

9. This is also an action for patent infringement under the patent laws of the United States, 35 U.S.C. §271. Samsung has infringed and continues to infringe U.S. Patent Nos. 8,102,805 (the '805 Patent); 8,607,130 (the '130 Patent); 9,949,239 (the '239 Patent); 9,532,355 (the '355 Patent); 10,454,655 (the '655 Patent); 10,193,600 (the '600 Patent); 10,425,817 (the '817 Patent); and 10,516,513 (the '513 Patent) (collectively “the Asserted Patents”).

### **PARTIES**

10. Plaintiff Ericsson Inc. is a Delaware corporation with its principal place of business at 6300 Legacy Drive, Plano, Texas 75024.

11. Plaintiff Telefonaktiebolaget LM Ericsson (“LME”) is a corporation organized under the laws of the Kingdom of Sweden with its principal place of business at Torshamnsgatan 21, Kista, 164 83, Stockholm, Sweden.

12. Defendant Samsung Electronics Co., Ltd. (“SEC”) is a Korean company with its principal place of business in Suwon, South Korea. SEC has an “Information Technology & Mobile Communications” division that is responsible for the design, manufacture, and sale of mobile devices, such as smartphones that operate on cellular networks around the world and in the United States.

13. Defendant Samsung Electronics America, Inc. (“SEA”) is a New York corporation with its principal place of business in Ridgefield Park, New Jersey, and it is a wholly-owned subsidiary of SEC. SEA imports into the United States and sells in the United States, including in this District, smartphones that operate on cellular networks in the United States. SEA imports into the United States and sells in the United States, including in this District, cellular network infrastructure equipment that operates on cellular networks in the United States. SEA is also responsible for research and development related to the cellular

standards, smartphones, cellular network infrastructure equipment, and other mobile devices, and has many employees involved in standardization.

14. Defendant Samsung Research America (“SRA”) is a California corporation with its principal place of business in Mountain View, California, and is a wholly-owned subsidiary of SEA. SRA is also responsible for research and development related to the cellular standards, smartphones, cellular network infrastructure equipment, and other mobile devices, and has many employees involved in standardization.

15. SEA and SRA maintain an office in this District at 6625 Excellence Way, Plano, Texas 75023, with more than 1,000 employees. Defendants SEA and SRA employ engineers—including in this District—that attend standardization meetings and work on research and development related to the cellular standards, smartphones, and other mobile devices. These engineers are the inventors on a variety of patents eventually assigned to Defendant SEC. SEC has included these patents in declarations to ETSI that form the basis of SEC’s FRAND commitment, contractually committing that SEC is prepared to grant licenses on FRAND terms and conditions to the extent such patents are and remain essential to the 2G, 3G, 4G, and/or 5G standards.

### **JURISDICTION AND VENUE**

16. This is an action for patent infringement under the patent laws of the United States, 35 U.S.C. §271. These claims also arise under the Declaratory Judgment Act, 28 U.S.C. §§ 2201 and 2202 and under the patent laws of the United States, Title 35, United States Code, Sections 1 et seq. This Court has subject matter jurisdiction under 28 U.S.C. §§ 1331, 1332 and 1338(a), and 1367.

17. The amount in controversy exceeds \$75,000.

18. Venue is proper in this judicial district under 28 U.S.C. §§ 1391 and 1400(b). Samsung has committed acts of patent infringement within the State of Texas and, more particularly, within the Eastern District of Texas. SEA maintains a corporate office at 6625 Excellence Way, Plano, TX 75023 in this District.

19. This Court has personal jurisdiction over Defendants Samsung. Samsung has continuous and systematic business contacts with the State of Texas. Samsung, directly or through subsidiaries or intermediaries (including distributors, retailers, and others), has negotiated with Ericsson in this District, and also conducts its business extensively throughout Texas, by shipping, distributing, offering for sale, selling, and advertising (including the provision of an interactive web page) its products and/or services in the State of Texas and the Eastern District of Texas. On information and belief, SEA's business operations relating to cellular mobile devices and cellular network infrastructure equipment, which are devices accused of infringement in this Action, are conducted at its Texas facilities, located at: 6625 Excellence Way, Plano, Texas; 1100 Klein Road, Plano, Texas; and 1301 East Lookout Drive, Richardson, Texas. SEA and SRA, SEC's wholly-owned subsidiaries, maintain an office in Plano, Texas, and are responsible for (1) importing and selling smartphones, tablets, other mobile devices, and cellular network infrastructure equipment that operate on cellular networks in the United States, (2) research and development related to the cellular standards, smartphones, cellular network infrastructure equipment, and other mobile devices, and (3) patent development activities related to such research and development. SEC, SEA, and SRA regularly do business or solicit business, engage in other persistent courses of conduct, and/or derive substantial revenue from products and/or services provided to individuals in the State of Texas.

20. SEC, SEA, and SRA, directly and through subsidiaries or intermediaries (including distributors, retailers, and others), have purposefully and voluntarily placed one or more products and/or services in the stream of commerce related to this dispute with the intention and expectation that they will be purchased and used by consumers in the Eastern District of Texas. These products and/or services have been and continue to be purchased and used by consumers in the Eastern District of Texas.

21. On information and belief the Samsung products accused of infringement in this case are manufactured, in whole or in part, by Samsung Electronics Thai Nguyen Co. Ltd. and Samsung Electronics Vietnam Co., Ltd., which are subsidiaries of Defendant Samsung Electronics Co., Ltd.

22. Samsung has purposefully directed its licensing activities into the Eastern District of Texas as to its portfolio of Essential Patents, as well as for Ericsson's portfolio of Essential Patents. Samsung employees have communicated, met, and engaged in patent licensing negotiations with Ericsson employees living and working in this District.

23. In other patent infringement matters involving Samsung's mobile products, such as *Clear Imaging Research, LLC v. Samsung Electronics Co., Ltd. et al.*, Samsung has admitted that for patent infringement actions involving mobile products, venue is proper in this District and that this Court may exercise personal jurisdiction over SEC and SEA. *Clear Imaging Research, LLC v. Samsung Electronics Co., Ltd. et al.*, No. 2:19-cv-326, Samsung Defendants' Answer at ¶8, Dkt. No. 23 (EDTX Jan. 22, 2020).

24. Ericsson Inc. is a corporation with its principal place of business in the Eastern District of Texas. Ericsson Inc. is a wholly-owned subsidiary of LME, and is responsible, among other things, for importing and selling cellular network infrastructure equipment to cellular



carriers in the United States. Ericsson Inc. requires a license on FRAND terms to the Essential Patents of Samsung.

### **FACTUAL BACKGROUND**

#### **A. Ericsson's Investment in Telecommunications**

25. Telefonaktiebolaget LM Ericsson was founded in 1876, and Ericsson Inc. is a wholly owned subsidiary of Telefonaktiebolaget LM Ericsson based in Plano, Texas. Ericsson supplies the cellular network infrastructure equipment used to build mobile networks across the world, serving more than one billion mobile subscribers in over 180 countries. In the United States, Ericsson's equipment is used by individuals utilizing AT&T, Verizon, Sprint, T-Mobile, and other cellular networks.

26. Ericsson has a long history of innovation in the telecommunication industry and in the creation of the cellular standards. In addition to supplying equipment for 2G, 3G, 4G, and 5G networks, Ericsson was also well-known for its mobile phone business—ending in 2012 with the divestment of the popular “Sony Ericsson” brand. Years earlier, Ericsson coined the “smartphone” term when unveiling its GS88 handset in 1997 and showcased an early version of a tablet with its Cordless Web Screen in 2000.

27. Ericsson prioritizes innovation and has invested \$4-5 billion annually in research and development. These research and development activities include participating in the development of the 2G, 3G, 4G, and 5G cellular standards over the last 30+ years. Ericsson's engineers have attended hundreds of standardization meetings and made tens of thousands of technical contributions to the standards.

28. Ericsson has been at the forefront of every step of cellular standardization: Ericsson launched 2G phones on the first 2G network in 1991, Ericsson made the first 3G call in 2001, and Ericsson built the first 4G network in 2009. And Ericsson continues to be at the

forefront: Ericsson completed the first 5G trial system in Europe in 2016, and Ericsson's equipment has been deployed in 5G networks in the United States.

29. Ericsson protects its investments in research and development with intellectual property. Ericsson owns thousands of patents related to wireless telecommunication technology, and Ericsson continues to develop and secure intellectual property as it innovates in this industry. Because Ericsson chooses to voluntarily contribute many of its research and development innovations to the standard-setting process—through technical contributions in standardization meetings—Ericsson has a large number of patents essential to the cellular standards. Industry members attending the standardization meetings, including Samsung, choose to adopt Ericsson's technology into the standard because Ericsson's technology is the best.

30. Ericsson has committed that it is prepared to grant licenses to any patents essential to the 2G, 3G, 4G, and 5G standards on fair, reasonable, and non-discriminatory (FRAND) terms and conditions. Knowing Ericsson's commitment to FRAND licensing, other makers of cellular devices and network equipment, including Samsung, continue to include Ericsson's technology in the 5G standard.

#### **B. ETSI and 3GPP**

31. The European Telecommunications Standards Institute (ETSI) is an independent, non-profit standard development organization (SDO) that produces globally accepted standards for the telecommunication industry. ETSI has more than 900 members from more than 60 countries across five continents, including Ericsson and Samsung. In addition to its own activities, ETSI is also one of seven SDOs that are organizational partners of the Third Generation Partnership Project (3GPP), which maintains and develops globally applicable technical specifications for the 2G (second generation, encompassing GSM, GPRS, as well as EDGE, which is considered 2.5G), 3G (third generation, encompassing WCDMA/UMTS and

HSPA), 4G (fourth generation, encompassing LTE, LTE-Advanced, and LTE Advanced-Pro), and 5G (fifth generation, encompassing NR) mobile systems. Together, ETSI and its members have developed open standards that ensure worldwide interoperability between networks, devices, and network operators.

32. Patents play an important role in developing the telecommunication industry through standardization and licensing. Many SDO members, including Ericsson, own intellectual property rights (IPRs) related to technologies contributed to and standardized by SDOs. Thus, technical standards adopted by SDOs may implicate member or non-member IPRs such that a patent license is required from the IPR owner to implement the standard.

33. ETSI has developed and promulgated an IPR Policy, which is a contract governed by French law. The ETSI IPR Policy is intended to strike a balance between the need for open standards on the one hand, and the rights of IPR owners on the other hand. ETSI requires its members to use reasonable endeavors to disclose patents that are essential to practice its standards or technical specifications. Clause 15.6 of the ETSI IPR Policy defines the term “ESSENTIAL” to mean that “it is not possible on technical (but not commercial) grounds, taking into account normal technical practice and the state of the art generally available at the time of standardization, to make, sell, lease, otherwise dispose of, repair, use or operate EQUIPMENT or METHODS which comply with a STANDARD without infringing that IPR.” Ericsson has fully complied with all aspects of the ETSI IPR Policy.

34. The ETSI IPR Policy includes a form “IPR Information Statement and Licensing Declaration.” Ericsson owns patents that are essential to practice the 2G, 3G, 4G, and/or 5G standards (“Essential Patents”). Ericsson has declared to ETSI that it is prepared to grant licenses on FRAND terms and conditions under its Essential Patents. Ericsson has licensed the bulk of

the industry under this commitment, previously including Samsung. Ericsson has offered to continue to license Samsung, but Samsung has insisted on non-FRAND rates.

35. Ericsson's commitment is subject to reciprocity, specifically, that it is prepared to grant licenses on FRAND terms and conditions under its Essential Patents subject to the "condition that those who seek licenses agree to reciprocate." The ETSI IPR Policy explicitly provides in Clause 6.1 that "[t]he above [FRAND] undertaking may be made subject to the condition that those who seek licenses agree to reciprocate." As a manufacturer of cellular infrastructure equipment, Ericsson typically negotiates cross-license agreements that provide Ericsson a reciprocal license to the other company's technology. For example, Ericsson's previous licenses with Samsung were cross-licenses where Ericsson also received a cross-license to Samsung's Essential Patents.

36. Like Ericsson, Samsung participates in standardization at ETSI and 3GPP. Engineers from SEA and SRA, for example, routinely attend 3GPP meetings, and also file patents related to cellular technology (which are eventually assigned to Defendant SEC). Samsung contends that it has a portfolio of Essential Patents, and Samsung has contractually committed to ETSI that it is likewise prepared to grant licenses under any such patents on FRAND terms and conditions. Ericsson is a third-party beneficiary to this contract and can enforce it.

### **C. Ericsson and Samsung's Prior Licenses**

37. Samsung designs, manufactures, and markets a portfolio of mobile devices, including in the United States and this District, that comply with the 2G, 3G, 4G, and 5G standards and utilize Ericsson's Essential Patents. Samsung also designs, manufactures, and markets cellular network infrastructure equipment, including in the United States and this

District, that complies with the 2G, 3G, 4G, and 5G standards and utilizes Ericsson's Essential Patents.

38. Ericsson designs, manufactures, and markets infrastructure equipment, including in the United States and in this District that complies with the 2G, 3G, 4G, and 5G standards and utilizes Samsung Essential Patents.

39. The parties have signed several cross-license agreements covering their respective patents, including most recently a multi-year agreement in 2014.

**D. The Parties' Negotiations**

40. Ericsson reached out to Samsung in February 2019 to begin negotiations regarding a new cross-license, as is Ericsson's typical practice when an existing license is expiring. Given the lengthy negotiations (and litigation) that preceded execution of the 2014 license, Ericsson sought to start negotiations early. Cross-license negotiations of this magnitude typically involve both technical discussions—to evaluate and challenge the strength of the other party's patents—and business discussions—to negotiate the terms of the agreement, informed by the feedback from the technical discussions.

41. The parties agreed to the objective to conclude negotiations by the end of this year and began technical discussions in the spring of 2020. The technical discussions covered both parties' portfolios of Essential Patents and spanned several meetings.

42. Then, Ericsson provided a presentation and offer in a meeting on July 20, 2020. Ericsson's proposal covered a global cross-license to both parties' Essential Patents, covering—along with patents around the world—the U.S. patents held by the parties to which their respective U.S. entities potentially require licenses. This cross-license proposal contained a balancing payment from Samsung to Ericsson, reflecting the parties' relative sales and the value of Ericsson's Essential Patents as compared to Samsung's.

43. All the terms of Ericsson's offer, including the balancing payment, were (and are) consistent with Ericsson's FRAND commitment.

44. Samsung rejected Ericsson's FRAND offer, and did not provide a counteroffer in response to Ericsson's offer until September 22, 2020. Samsung's eventual counteroffer was unreasonably low. Samsung's counteroffer evidenced that Samsung was not negotiating in good faith and not willing to enter into a cross-license on FRAND terms and, rather, would only be willing to pay Ericsson a rate for Ericsson's Essential Patents that was significantly below FRAND. Samsung's counteroffer and rejection of Ericsson's FRAND offer are inconsistent with Samsung's FRAND commitment.

45. Sensing that the parties were reaching impasse in the business negotiations, Ericsson sent Samsung an arbitration offer on September 27, 2020. This arbitration offer provided the option to resolve the global dispute between the parties via a neutral, third-party determination of the appropriate FRAND rate for a global cross-license. As is typical with such offers, it included a 45-day window for Samsung to accept the offer. In parallel, Ericsson continued to attempt to engage in negotiations with Samsung in addition to providing the arbitration offer.

46. Samsung did not respond to Ericsson's arbitration offer until November 10, 2020—44 days after it was made. Samsung did not accept Ericsson's arbitration offer, despite the impasse the parties seemed to have reached on royalty terms.

47. Negotiations have continued, but no progress has been made. It has become clear that Samsung had no intention of negotiating in good faith towards concluding an agreement with Ericsson on FRAND terms and conditions. Instead, Samsung has insisted on a below-

FRAND royalty payment in a cross-license and, by doing so, Samsung has deprived Ericsson of its right to a reciprocal global license to Samsung's Essential Patents on FRAND terms.

**E. The Asserted Patents**

48. On January 24, 2012, the U.S. Patent and Trademark Office duly and legally issued U.S. Patent No. 8,102,805 (the '805 Patent), entitled "HARQ in Spatial Multiplexing MIMO System," to inventors Bo Göransson, Per Johan Torsner, and Stefan Parkvall. Ericsson owns all rights to the '805 Patent necessary to bring this action.

49. On December 10, 2013, the U.S. Patent and Trademark Office duly and legally issued U.S. Patent No. 8,607,130 (the '130 Patent) entitled "Computationally Efficient Convolutional Coding with Rate-Matching," to inventor Jung-Fu Cheng. Ericsson owns all rights to the '130 Patent necessary to bring this action.

50. On April 17, 2018, the U.S. Patent and Trademark Office duly and legally issued U.S. Patent No. 9,949,239 (the '239 Patent), entitled "Uplink Scrambling During Random Access," to inventors Stefan Parkvall, Erik Dahlman, and Tobias Tynderfeldt. Ericsson owns all rights to the '239 Patent necessary to bring this action.

51. On May 7, 2013, the U.S. Patent and Trademark Office duly and legally issued U.S. Patent No. 9,532,355 (the '355 Patent), entitled "Transmission of System Information on a Downlink Shared Channel," to inventors Erik Dahlman and Vera Vukajlovic Kenehan. Ericsson owns all rights to the '355 Patent necessary to bring this action.

52. On October 22, 2019, the U.S. Patent and Trademark Office duly and legally issued U.S. Patent No. 10,454,655 (the '655 Patent), entitled "Wireless Terminals, Nodes of Wireless Communication Networks, and Methods of Operating the Same," to inventors Mattias Tan Bergstrom and Magnus Stattin. Ericsson owns all rights to the '655 Patent necessary to bring this action.

53. On January 29, 2019, the U.S. Patent and Trademark Office duly and legally issued U.S. Patent No. 10,193,600 (the '600 Patent), entitled "Codebook Subset Restriction Signaling" to inventors Sebastian Faxér, Mattias Frenne, Simon Järmyr, George Jöngren, and Niklas Wernersson. Ericsson owns all rights to the '600 Patent necessary to bring this action.

54. On September 24, 2019, the U.S. Patent and Trademark Office duly and legally issued U.S. Patent No. 10,425,817 (the '817 Patent), entitled "Subscription Concealed Identifier" to inventors Noamen Ben Henda, David Castellanos Zamora, Prajwol Kumar Nakarmi, Pasi Saarinen, and Monica Wifvesson. Ericsson owns all rights to the '817 Patent necessary to bring this action.

55. On December 24, 2019, the U.S. Patent and Trademark Office duly and legally issued U.S. Patent No. 10,516,513 (the '513 Patent), entitled "Controllable CSI-RS Density" to inventors Stephen Grant and Mattias Frenne. Ericsson owns all rights to the '513 Patent necessary to bring this action.

**F. Claims for Patent Infringement and Declaratory Judgment**

56. Samsung has directly and indirectly infringed and continues to directly and indirectly infringe each of the Asserted Patents by engaging in acts constituting infringement under 35 U.S.C. § 271(a), (b), (c) and/or (f), including but not limited to one or more of making, using, selling, offering for sale, importing, exporting, and inducing and contributing to infringement by others, in this District and elsewhere in the United States. Samsung imports, owns, operates, and/or sells wireless communications products, including products that Samsung represents support "4G," "5G," and/or "LTE" connectivity. *See, e.g.,* <https://www.samsung.com/us/mobile/galaxy-a51>). Samsung's Accused Products infringe each of the Asserted Patents based on at least their practice of 4G standards (including the 3GPP 4G LTE Standard) and/or their practice of the 5G standards (including 3GPP 5G NR Standard). Samsung



instructs its customers to use the Accused Products in manners that infringe the Asserted Patents. For example, Samsung provides instruction manuals for the Accused Products and describes, markets, and/or advertises the Accused Products on its website. On information and belief, Samsung tests each of the Accused Products in the United States, thus infringing the Asserted Patents.

57. Samsung's infringement of the Asserted Patents has been, and continues to be, willful. In accordance with 35 U.S.C. § 287, Samsung has had actual notice and knowledge of the Asserted Patents no later than the filing of this Complaint and/or the date this Complaint was served upon Samsung. Samsung has committed acts of infringement despite a high likelihood that its actions constitute infringement, and Samsung knew or should have known that its actions constituted an unjustifiably high risk of infringement.

58. The allegations provided are exemplary and without prejudice to Plaintiffs' infringement contentions provided pursuant to the Court's scheduling order and Local Rules. Plaintiffs' claim construction contentions regarding the meaning and scope of the claim terms will be provided under the Court's scheduling order and Local Rules. Each element of at least one claim of each of the Asserted Patents is literally present in the Accused Products. To the extent that any element is not literally present, each such element is present under the doctrine of equivalents. Plaintiffs' analysis should not be taken as an admission that the preamble of each of the claims is limiting, and Plaintiffs reserves the right to argue that the preamble is not limiting for any of the claims. While publicly available information is discussed and/or cited, Plaintiffs may rely on other forms of evidence to show infringement.

59. Samsung's Accused Products make use of the Asserted Patents to practice the 4G and/or 5G standards. As a result, Samsung's Accused Products infringe any essential claims of the Asserted Patents.

60. The Accused Products include at least the following products, as well as products with reasonably similar functionality: Galaxy S20 5G UW; Galaxy S20 FE 5G; Galaxy Note20 5G; Galaxy Note20 Ultra 5G; Galaxy Z Fold2; Galaxy Z Flip 5G; Galaxy A51 5G UW; Galaxy A51 5G; Galaxy A71 5G UW; Galaxy M31 Prime; Galaxy Note20 LTE; Galaxy Note20 Ultra LTE; Galaxy S20+; Galaxy S20; Galaxy A10e; Galaxy A20; Galaxy S20+ (5G); Galaxy S20 (5G); Galaxy S10; Galaxy S10 5G; Galaxy A01; Galaxy S10+; Galaxy S20 Ultra (5G); Galaxy S20; Galaxy A50; Galaxy A51; Galaxy Note10+; Galaxy Note10+ 5G; Galaxy J2 Dash; Galaxy S10e; Galaxy A11; Galaxy J2 Pure; Galaxy Note10; Galaxy A71 5G; Galaxy A21; Galaxy S9; Galaxy J2 (2018); Galaxy Note9; Galaxy S9+; Galaxy S10 Lite; Galaxy S8; Galaxy J3 Orbit; Galaxy S8+; Xcover Pro; Galaxy Fold; Galaxy Z Flip; Galaxy J3 Achieve; Galaxy J7 V 2nd; Galaxy J3 Top; Galaxy J7 (2018); Galaxy S8 Active; Galaxy J3 V 3rd; Galaxy Sol 3; Galaxy Tab A 10.1 (2019); Galaxy Tab A 8.4" (2020); Galaxy Book S; Galaxy Tab S6 10.5"; Galaxy Tab S5e 10.5"; Galaxy Tab S7+; Galaxy Tab S7; Galaxy Tab S4 10.5"; Galaxy Tab A 8.0"; Galaxy View2 (2019).

61. The Accused Products also include Samsung's 5G infrastructure products, *e.g.*, base stations, including but not necessarily limited to: the 64T64R MMU, 32T32R MMU, 8T8R Radio, 4T4R Radio, 2T2R Radio, the Compact Macro 5G radio (also called the Access Unit), the 5G mmwave Link Cell, the CDU50 and CDU30 baseband units and/or other associated base station components (the Base Station Accused Products). The Accused Products further include

Samsung's core network products, including Cloud Native Core and Compact Core (the Core Network Accused Products).

62. Further identification of the Accused Products will be provided in Plaintiffs' infringement contentions pursuant to the Court's scheduling order and Local Rules.

### **COUNT I: BREACH OF CONTRACT**

63. Ericsson incorporates by reference the preceding paragraphs as though fully set forth herein.

64. Samsung designs, manufactures, and markets products that comply with the 2G, 3G, 4G, and 5G standards. Samsung contends it owns Essential Patents.

65. Ericsson designs, manufactures, and markets products that comply with the 2G, 3G, 4G, and 5G standards. Ericsson also owns Essential Patents.

66. Samsung, as the owner of patents it contends are essential, and remain essential, to ETSI standards, has contractually committed to ETSI to be prepared to grant licenses to any such patents on FRAND terms and conditions to third parties, such as Ericsson, who implement equipment compliant with the standards.

67. Ericsson, as the owner of patents it contends are essential, and remain essential, to ETSI standards, has likewise contractually committed to ETSI to be prepared to grant licenses to any such patents on FRAND terms and conditions to third parties, such as Samsung, who implement equipment compliant with the standards, subject to reciprocity.

68. Ericsson is an intended third-party beneficiary of Samsung's contract with ETSI. Likewise, Samsung is an intended third-party beneficiary of Ericsson's contract with ETSI.

69. Samsung is obligated to offer a license to its essential patents consistent with the ETSI IPR Policy and its contractual declarations, including that such license be on FRAND

terms and conditions. Samsung has breached its contractual commitment, as set forth in Samsung's IPR licensing declarations to ETSI and the ETSI IPR Policy.

70. Since at least late 2019, representatives from Ericsson and Samsung have been engaged in negotiations regarding a cross-license to each party's Essential Patents.

71. Ericsson made an offer to license its Essential Patents to Samsung on FRAND terms and conditions. Consistent with the parties' FRAND commitments, Ericsson's offer was for a global cross-license that took into account both parties' Essential Patents and standard-compliant products and required Samsung to make a FRAND-compliant balancing royalty payment to Ericsson.

72. Samsung rejected Ericsson's offer for a cross-license and instead insisted on an unreasonably low, non-FRAND rate for the cross-license. In doing so, Samsung violated its FRAND commitment by effectively depriving Ericsson of its right as a third-party beneficiary to a license to Samsung's Essential Patents on FRAND terms.

73. Samsung's positions are inconsistent with its contractual commitment to ETSI, as set forth in Samsung's IPR licensing declarations to ETSI and the ETSI IPR Policy. Ericsson is a third-party beneficiary of that contract, which Samsung has breached in its negotiations with Ericsson.

74. This breach has caused harm to Ericsson. Samsung's refusal to offer a cross-license on FRAND terms and conditions has caused Ericsson to expend resources in futile negotiations, deprived Ericsson of a FRAND cross-license, and threatens Ericsson with a gap in license coverage.

75. Samsung's breach has caused Ericsson to suffer actual damages, such as Ericsson's costs and expenses in pursuing futile negotiations with Samsung in an amount to be

determined at trial. In addition, Ericsson is further entitled to obtain specific performance under French law.

76. Ericsson has suffered and will continue to suffer irreparable injury by reason of the acts, practices, and conduct of Samsung alleged above until and unless the Court enjoins such acts, practices, and conduct.

## **COUNT II: BREACH OF OBLIGATION TO NEGOTIATE IN GOOD FAITH**

77. Ericsson incorporates by reference the preceding paragraphs as though fully set forth herein.

78. French law governs the ETSI FRAND commitment, and under French law, once Samsung commenced negotiations with Ericsson for a cross-license, Samsung was obligated to negotiate in good faith. Samsung has failed to negotiate in good faith with Ericsson and thus breached its obligation. For example, rather than engage in good-faith negotiations, Samsung did not seriously engage in negotiations with Ericsson with the aim of concluding an agreement, and instead made an unreasonably low cross-license counteroffer, effectively depriving Ericsson of a license to Samsung's Essential Patents on FRAND terms.

79. Samsung's failure to negotiate in good faith constitutes a breach of its obligations to Ericsson.

80. There is a dispute between Ericsson and Samsung concerning whether Samsung has complied with its obligation to negotiate in good faith, and this controversy is of sufficient immediacy and reality to warrant the issuance of a declaratory judgment.

81. Ericsson is entitled to a declaratory judgment that Samsung has not complied with its obligation to act in good faith during its negotiations with Ericsson in regard to FRAND terms for a cross-license to the parties' Essential Patents.

82. As a result of Samsung's breach of its duty to negotiate in good faith, Ericsson has been injured in its business or property, including Ericsson's cost and expenses in pursuing futile negotiations with Samsung in an amount to be determined at trial.

**COUNT III: DECLARATORY JUDGMENT THAT ERICSSON HAS NOT BREACHED  
ITS FRAND COMMITMENT**

83. Ericsson incorporates by reference the preceding paragraphs as though fully set forth herein.

84. Ericsson has fully complied with the ETSI IPR Policy, its FRAND obligations and all other applicable laws by, among other things, attempting to negotiate in good faith with Samsung and offering Samsung a cross-license to Ericsson's Essential Patents on FRAND terms and conditions.

85. A dispute exists between Ericsson and Samsung concerning whether Ericsson's offer to Samsung for a global cross-license to the parties' Essential Patents violated Ericsson's commitment that it is prepared to grant licenses under its Essential Patents on terms and conditions consistent with Ericsson's IPR licensing declarations to ETSI and ETSI's IPR Policy. Samsung rejected Ericsson's offer. There is a case or controversy of sufficient immediacy, reality, and ripeness to warrant the issuance of a declaratory judgment.

86. Ericsson requests a declaratory judgment that Ericsson's global, reciprocal cross-license offered during the negotiations with Samsung complied with Ericsson's FRAND commitment, as set forth in its IPR licensing declarations to ETSI, that Ericsson's conduct in negotiations with Samsung has not breached ETSI's IPR Policy or any applicable competition laws, and that Ericsson has fully complied with the ETSI IPR Policy in all respects.

**COUNT IV: DECLARATORY JUDGMENT THAT SAMSUNG HAS BREACHED ITS  
FRAND COMMITMENT TO ERICSSON**

87. Ericsson incorporates by reference the preceding paragraphs as though fully set forth herein.

88. Samsung's positions are inconsistent with its contractual commitment to ETSI, as set forth in Samsung's IPR licensing declarations to ETSI. Ericsson is a third-party beneficiary of that contract, which Samsung has breached in its negotiations with Ericsson.

89. A dispute exists between Ericsson and Samsung concerning whether Samsung has complied with its commitment to be prepared to grant licenses to its Essential Patents on terms and conditions consistent with Samsung's IPR licensing declarations to ETSI and ETSI's IPR Policy. Samsung demanded a cross-license with an unreasonably low, non-FRAND rate for Ericsson's valuable Essential Patents, thereby effectively depriving Ericsson of its rights to a license to Samsung's Essential Patents on FRAND terms. This is inconsistent with Samsung's contractual commitment, and Samsung has thus breached its contractual obligation that it be prepared to grant licenses to its Essential Patents on terms and conditions consistent with Samsung's IPR licensing declarations to ETSI and ETSI's IPR Policy. There is a case or controversy of sufficient immediacy, reality, and ripeness to warrant the issuance of a declaratory judgment.

90. Ericsson requests a declaratory judgment that Samsung has breached Samsung's FRAND commitment, as set forth in its IPR licensing declarations to ETSI, as well as ETSI's IPR Policy and any applicable laws.

**COUNT V: DECLARATORY JUDGMENT THAT SAMSUNG HAS FAILED TO  
NEGOTIATE IN GOOD FAITH WITH ERICSSON**

91. Ericsson incorporates by reference the preceding paragraphs as though fully set forth herein.

92. Under French law, once Samsung commenced negotiations with Ericsson for a cross-license, Samsung was obligated to negotiate in good faith. Samsung has failed to negotiate in good faith with Ericsson and has breached its obligation. For example, Samsung did not seriously engage in negotiations with Ericsson with the aim of concluding an agreement, and instead made an unreasonably low cross-license counteroffer, effectively depriving Ericsson of a license to Samsung's Essential Patents on FRAND terms.

93. Samsung's failure to negotiate in good faith constitutes a breach of its obligations to Ericsson.

94. There is a dispute between Ericsson and Samsung concerning whether Samsung has complied with its obligation to negotiate in good faith, and this controversy is of sufficient immediacy, reality, and ripeness to warrant the issuance of a declaratory judgment.

95. Ericsson is entitled to a declaratory judgment that Samsung has not complied with its obligation to act in good faith during its negotiations with Ericsson in regard to FRAND terms for a cross-license to the parties' Essential Patents, and as a consequence, that Samsung has repudiated and forfeited its right to claim rights as a third-party beneficiary of Ericsson's FRAND commitment to ETSI.

**COUNT VI: PATENT INFRINGEMENT AND DECLARATORY JUDGMENT OF  
PATENT INFRINGEMENT OF THE '805 PATENT**

96. Ericsson incorporates by reference the preceding paragraphs as though fully set forth herein.





97. Samsung infringes and/or induces infringement of at least claims 19 and 26 of the '805 Patent, either literally or under the doctrine of equivalents, by making, using, selling, offering for sale, and/or importing into the United States the Accused Products that are covered by one or more claims of the '805 Patent.



98. On information and belief, Samsung will infringe and/or induce infringement of at least claims 19 and 26 of the '805 Patent, either literally or under the doctrine of equivalents, by making, using, selling, offering for sale, and/or importing into the United States the Accused Products that are covered by one or more claims of the '805 Patent.

99. The Accused Products directly infringe one or more claims of the '805 Patent. Samsung makes, uses, sells, offers for sale, and/or imports, in this District and elsewhere in the United States the Accused Products and thus directly infringes claims of the '805 Patent.

100. For example and as shown below, the Samsung Galaxy A51 infringes claim 19 of the '805 patent by virtue of its compatibility with and practice of the 3GPP 4G LTE Standard.

Compare	 Galaxy A51 5G	 Galaxy A51	 Galaxy A71 5G	 Galaxy A21
Colors	● Prism Cube Black	● Prism Crush Black ● Prism Crush Blue ○ Prism Crush White	● Prism Cube Black	● Black
Screen size*	6.5"	6.5"	6.7"	6.5"
Internal Storage	128GB	128GB	128GB	32GB
RAM	6GB	4GB	6GB	3GB
Expandable Storage**	up to 1,000GB	up to 512GB	up to 1,000GB	up to 512GB
Cellular & Wireless***	5G, Sub 6	4G LTE	5G, Sub 6	4G LTE

101. For example, and to the extent the preamble is limiting, the Samsung Galaxy A51 is a receiver subsystem in a spatial multiplexing wireless communications system.

<sup>1</sup> <https://www.samsung.com/us/mobile/galaxy-a51/>

Step 1 Samsung Galaxy A51 Teardown

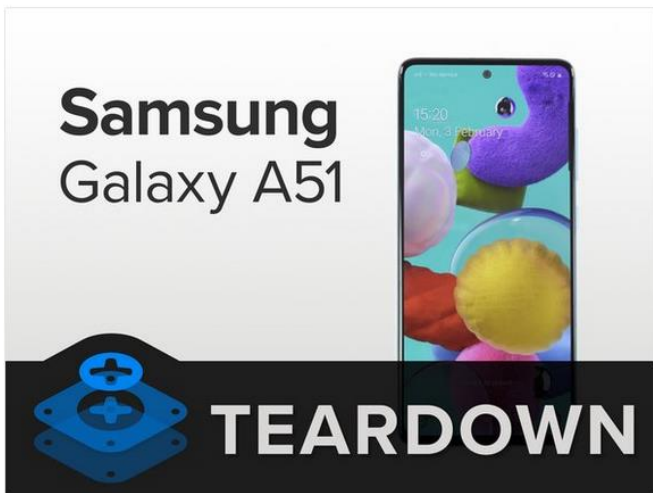

- The specs may not impress at first sight, but there's quite a lot here for the price:
  - 6.5" Super AMOLED capacitive touchscreen (1080 × 2400px) and Infinity-O Display
  - 48 MP f2.0 main camera, 12 MP f2.2 ultra wide camera, 5 MP f2.4 macro camera for close-ups and a 5 MP f2.2 depth camera for multiple live focus effects; 32 MP f2.2 front-facing camera
  - Exynos 9611, octa-core (4×2.3GHz Cortex-A73, 4×1.7GHz Cortex-A53)
  - Built-in storage: 64GB/4GB RAM, 128GB/4GB RAM, 128GB/6GB RAM
  - Android 10.0
  - Fast wired charging with 15W
  - USB-C and a nearly extinct 3.5 mm headphone jack

Step 7

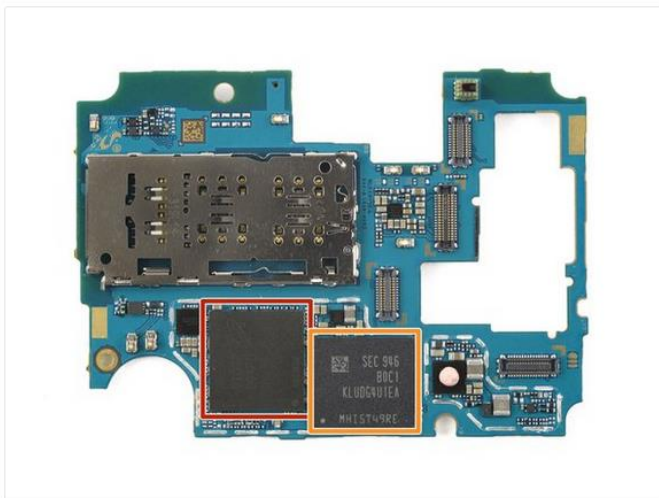

- Let's see what goodies we can find on the motherboard:
  - Micron MT53D1024M32D4BD-046 LPDDR4 memory covering the Exynos 9611, octa-core CPU with Mali-G72 MP3 GPU
  - KLUDG4U1EA-B0C1 128GB UFS 2.1 flash storage

2

102. In addition, the exemplary Samsung Galaxy A51 receives first and second transport blocks, the first and second transport blocks having been simultaneously transmitted

<sup>2</sup> <https://www.ifixit.com/Teardown/Samsung+Galaxy+A51+Teardown/131053>

during a first transmission interval on first and second data substreams, respectively. This functionality is described in the 4G LTE Standard, including but not limited to in 3GPP TS 36.212 V8.4.0 § 5.3.3.

103. In addition, the exemplary Samsung Galaxy A51 receives a re-transmitted one of the first or second transport blocks during a second transmission interval. This functionality is described in the 4G LTE Standard, including but not limited to 3GPP TS 36.321 V8.4.0 § 5.4.2.1 and TS 36.212 V8.4.0 § 5.3.3.

104. In addition, the exemplary Samsung Galaxy A51 receives first scheduling information for the first transmission interval, the first scheduling information comprising a single re-transmission process identifier and first disambiguation data, wherein the first disambiguation data indicates whether the first transport block is associated with the first or second data substream, and whether the second transport block is associated with the first or second data substream. This functionality is described in the 4G LTE Standard, including but not limited to 3GPP TS 36.212 V8.4.0 § 5.3.3.1.5 and TS 36.321 § 5.3.

105. In addition, the exemplary Samsung Galaxy A51 receives second scheduling information for the second transmission interval, the second scheduling information comprising the re-transmission process identifier and second disambiguation data. This functionality is described in the 4G LTE Standard, including but not limited to 3GPP TS 36.212 § 5.3.3.1.5.

106. In addition, the exemplary Samsung Galaxy A51 the second disambiguation data to determine whether the re-transmitted transport block is scheduled for retransmission on the first data substream or the second data substream during the second transmission interval. This functionality is described in the 4G LTE Standard, including but not limited to 3GPP TS 36.321 § 5.3.2.2.

107. Samsung had actual knowledge and notice of the '805 Patent no later than the filing of this Complaint and/or the date this Complaint was served upon Samsung. On information and belief, Samsung has had knowledge and notice of the '805 Patent, or should have known of the '805 Patent but were willfully blind to its existence, at least as a result of prior license agreements between Samsung and Ericsson and/or the filing of this Complaint.

108. Samsung also indirectly infringes claims of the '805 Patent, as provided in 35 U.S.C. § 271(b), by inducing infringement by others, such as Samsung's distributors, customers, and end-users, in this District and elsewhere in the United States. For example, Samsung's customers and end-users directly infringe through their use of the inventions claimed in the '805 Patent. Samsung induces this direct infringement through its affirmative acts of manufacturing, selling, distributing, and/or otherwise making available the Accused Products, and providing instructions, documentation, online technical support, marketing, product manuals, advertisements and other information to customers and end users suggesting they use the Accused Products in an infringing manner. As a result of Samsung's inducement, Samsung's customers and end users use the Accused Products in the way Samsung intends and directly infringe the '805 Patent. Samsung has performed and continues to perform these affirmative acts with knowledge of the '805 Patent and with the intent, or willful blindness, that the induced acts directly infringe the '805 Patent.

109. Samsung's infringement of the '805 Patent was willful and deliberate, entitling Ericsson to enhanced damages and attorneys' fees.

**COUNT VII: PATENT INFRINGEMENT AND DECLARATORY JUDGMENT OF  
PATENT INFRINGEMENT OF THE '130 PATENT**





110. Ericsson incorporates by reference the preceding paragraphs as though fully set forth herein.

111. Samsung infringes and/or induces infringement of at least claims 1, 6, 8, 12, and 14 of the '130 Patent, either literally or under the doctrine of equivalents, by making, using, selling, offering for sale, and/or importing into the United States the Accused Products that are covered by one or more claims of the '130 Patent.

112. On information and belief, Samsung will infringe and/or induce infringement of at least claims 1, 6, 8, 12, and 14 of the '130 Patent, either literally or under the doctrine of equivalents, by making, using, selling, offering for sale, and/or importing into the United States the Accused Products that are covered by one or more claims of the '130 Patent.

113. The Accused Products directly infringe one or more claims of the '130 Patent. Samsung makes, uses, sells, offers for sale, and/or imports, in this District and elsewhere in the United States the Accused Products and thus directly infringes claims of the '130 Patent.

114. For example and as shown below, the Samsung Galaxy A51 infringes claim 1 of the '130 patent by virtue of its compatibility with and practice of the 3GPP 4G LTE Standard.

Compare	 Galaxy A51 5G	 Galaxy A51	 Galaxy A71 5G	 Galaxy A21
Colors	● Prism Cube Black	● Prism Crush Black ● Prism Crush Blue ○ Prism Crush White	● Prism Cube Black	● Black
Screen size*	6.5"	6.5"	6.7"	6.5"
Internal Storage	128GB	128GB	128GB	32GB
RAM	6GB	4GB	6GB	3GB
Expandable Storage**	up to 1,000GB	up to 512GB	up to 1,000GB	up to 512GB
Cellular & Wireless***	5G, Sub 6	4G LTE	5G, Sub 6	4G LTE

3

<sup>3</sup> <https://www.samsung.com/us/mobile/galaxy-a51/>

115. For example, and to the extent the preamble is limiting, the Samsung Galaxy A51 comprises user equipment comprising a baseband processor, which includes error coding circuits.

### Step 1 Samsung Galaxy A51 Teardown

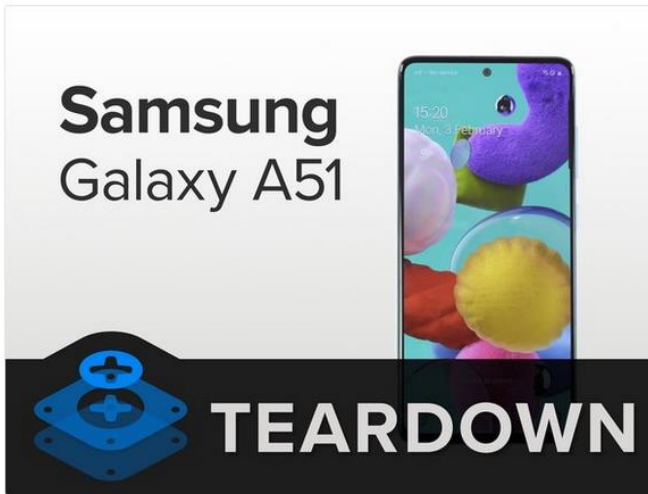

- The specs may not impress at first sight, but there's quite a lot here for the price:
- 6.5" Super AMOLED capacitive touchscreen (1080 × 2400px) and Infinity-O Display
- 48 MP f2.0 main camera, 12 MP f2.2 ultra wide camera, 5 MP f2.4 macro camera for close-ups and a 5 MP f2.2 depth camera for multiple live focus effects; 32 MP f2.2 front-facing camera
- Exynos 9611, octa-core (4×2.3GHz Cortex-A73, 4×1.7GHz Cortex-A53)
- Built-in storage: 64GB/4GB RAM, 128GB/4GB RAM, 128GB/6GB RAM
- Android 10.0
- Fast wired charging with 15W
- USB-C and a nearly extinct 3.5 mm headphone jack

### Step 7

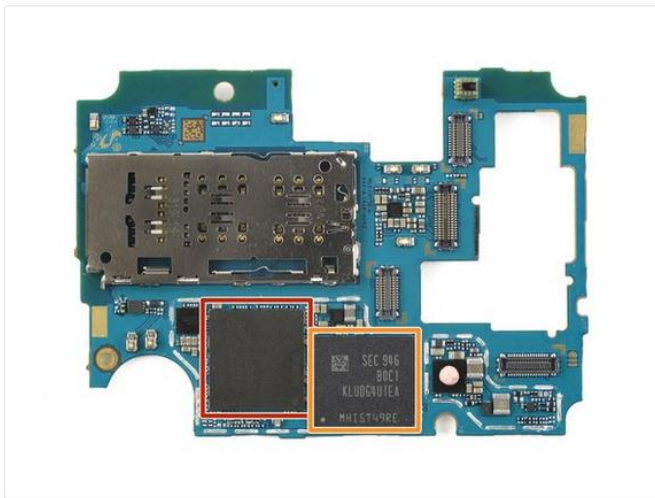

- Let's see what goodies we can find on the motherboard:
- Micron MT53D1024M32D4BD-046 LPDDR4 memory covering the Exynos 9611, octa-core CPU with Mali-G72 MP3 GPU
- KLUDG4U1EA-B0C1 128GB UFS 2.1 flash storage

4

<sup>4</sup> <https://www.ifixit.com/Teardown/Samsung+Galaxy+A51+Teardown/131053>

116. For example, and as shown below, the Samsung Galaxy A51 includes an error coding circuit comprising a non-systemic convolutional encoder for coding an input but stream to produce two or more groups of parity bits. As shown below, this functionality is described in the 4G LTE Standard, including but not limited to in 3GPP TS 36.212 §§ 5.1.3 and 5.1.3.1

**5.1.3 Channel coding**

The bit sequence input for a given code block to channel coding is denoted by  $c_0, c_1, c_2, c_3, \dots, c_{K-1}$ , where  $K$  is the number of bits to encode. After encoding the bits are denoted by  $d_0^{(i)}, d_1^{(i)}, d_2^{(i)}, d_3^{(i)}, \dots, d_{D-1}^{(i)}$ , where  $D$  is the number of encoded bits per output stream and  $i$  indexes the encoder output stream. The relation between  $c_k$  and  $d_k^{(i)}$  and between  $K$  and  $D$  is dependent on the channel coding scheme.

The following channel coding schemes can be applied to TrCHs:

- tail biting convolutional coding;

**5.1.3.1 Tail biting convolutional coding**

A tail biting convolutional code with constraint length 7 and coding rate 1/3 is defined.

The configuration of the convolutional encoder is presented in figure 5.1.3-1.

The initial value of the shift register of the encoder shall be set to the values corresponding to the last 6 information bits in the input stream so that the initial and final states of the shift register are the same. Therefore, denoting the shift register of the encoder by  $s_0, s_1, s_2, \dots, s_5$ , then the initial value of the shift register shall be set to

$$s_i = c_{(K-1-i)}$$

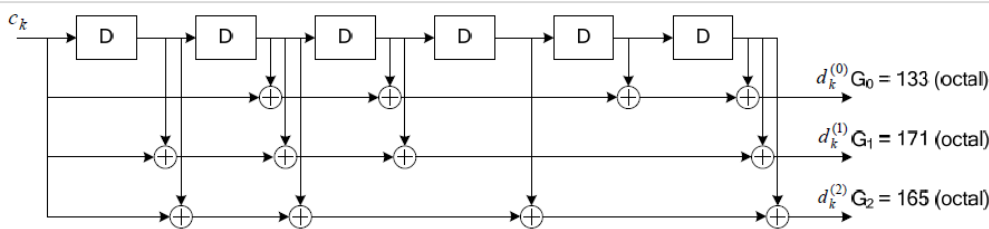

**Figure 5.1.3-1: Rate 1/3 tail biting convolutional encoder**

The encoder output streams  $d_k^{(0)}$ ,  $d_k^{(1)}$  and  $d_k^{(2)}$  correspond to the first, second and third parity streams, respectively as shown in Figure 5.1.3-1.

117. For example, and as shown below, the Samsung Galaxy A51 includes an error coding circuit comprising an interleaver circuit for interleaving parity bits within each group of parity bits, wherein the interleaver circuit is configured to order parity bits such that odd parity bits precede even parity bits within each group of parity bits. As shown below, this functionality



is described in the 4G LTE Standard, including but not limited to in 3GPP TS 36.212 § 5.1.4.2.1 and Figure 5.1.4-2.

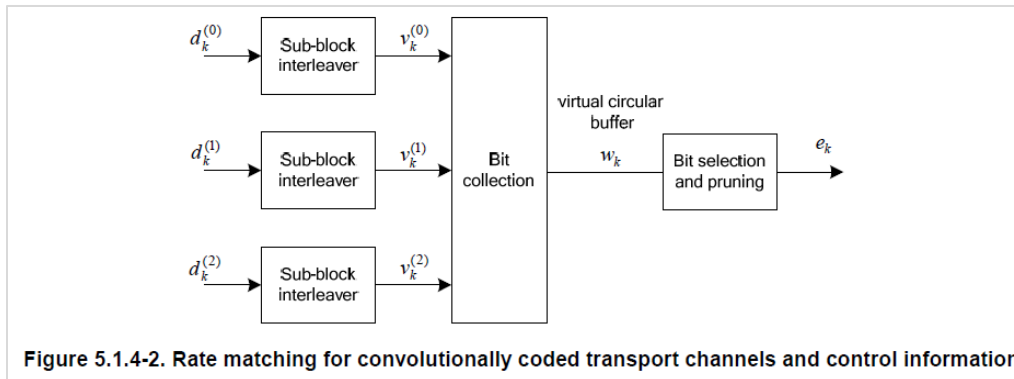

Figure 5.1.4-2. Rate matching for convolutionally coded transport channels and control information

#### 5.1.4.2.1 Sub-block interleaver

The bits input to the block interleaver are denoted by  $d_0^{(i)}, d_1^{(i)}, d_2^{(i)}, \dots, d_{D-1}^{(i)}$ , where  $D$  is the number of bits. The output bit sequence from the block interleaver is derived as follows:

- (1) Assign  $C_{subblock}^{CC} = 32$  to be the number of columns of the matrix. The columns of the matrix are numbered  $0, 1, 2, \dots, C_{subblock}^{CC} - 1$  from left to right.

- (2) Determine the number of rows of the matrix  $R_{subblock}^{CC}$ , by finding minimum integer  $R_{subblock}^{CC}$  such that:

$$D \leq (R_{subblock}^{CC} \times C_{subblock}^{CC})$$

The rows of rectangular matrix are numbered  $0, 1, 2, \dots, R_{subblock}^{CC} - 1$  from top to bottom.

- (3) If  $(R_{subblock}^{CC} \times C_{subblock}^{CC}) > D$ , then  $N_D = (R_{subblock}^{CC} \times C_{subblock}^{CC} - D)$  dummy bits are padded such that  $y_k = \langle NULL \rangle$  for  $k = 0, 1, \dots, N_D - 1$ . Then, write the input bit sequence, i.e.  $y_{N_D+k} = d_k^{(i)}$ ,  $k = 0, 1, \dots, D-1$ , into the  $(R_{subblock}^{CC} \times C_{subblock}^{CC})$  matrix row by row starting with bit  $y_0$  in column 0 of row 0:

$$\begin{bmatrix} y_0 & y_1 & y_2 & \cdots & y_{C_{subblock}^{CC}-1} \\ y_{C_{subblock}^{CC}} & y_{C_{subblock}^{CC}+1} & y_{C_{subblock}^{CC}+2} & \cdots & y_{2C_{subblock}^{CC}-1} \\ \vdots & \vdots & \vdots & \ddots & \vdots \\ y_{(R_{subblock}^{CC}-1) \times C_{subblock}^{CC}} & y_{(R_{subblock}^{CC}-1) \times C_{subblock}^{CC}+1} & y_{(R_{subblock}^{CC}-1) \times C_{subblock}^{CC}+2} & \cdots & y_{(R_{subblock}^{CC} \times C_{subblock}^{CC}-1)} \end{bmatrix}$$

- (4) Perform the inter-column permutation for the matrix based on the pattern  $\langle P(j) \rangle_{j \in \{0, 1, \dots, C_{subblock}^{CC}-1\}}$  that is shown in table 5.1.4-2, where  $P(j)$  is the original column position of the  $j$ -th permuted column. After permutation of the columns, the inter-column permuted  $(R_{subblock}^{CC} \times C_{subblock}^{CC})$  matrix is equal to

$$\begin{bmatrix} y_{P(0)} & y_{P(1)} & y_{P(2)} & \cdots & y_{P(C_{subblock}^{CC}-1)} \\ y_{P(0)+C_{subblock}^{CC}} & y_{P(1)+C_{subblock}^{CC}} & y_{P(2)+C_{subblock}^{CC}} & \cdots & y_{P(C_{subblock}^{CC}-1)+C_{subblock}^{CC}} \\ \vdots & \vdots & \vdots & \ddots & \vdots \\ y_{P(0)+(R_{subblock}^{CC}-1) \times C_{subblock}^{CC}} & y_{P(1)+(R_{subblock}^{CC}-1) \times C_{subblock}^{CC}} & y_{P(2)+(R_{subblock}^{CC}-1) \times C_{subblock}^{CC}} & \cdots & y_{P(C_{subblock}^{CC}-1)+(R_{subblock}^{CC}-1) \times C_{subblock}^{CC}} \end{bmatrix}$$



(5) The output of the block interleaver is the bit sequence read out column by column from the inter-column permuted  $(R_{subblock}^{CC} \times C_{subblock}^{CC})$  matrix. The bits after sub-block interleaving are denoted by  $v_0^{(i)}, v_1^{(i)}, v_2^{(i)}, \dots, v_{K_{\Pi}-1}^{(i)}$ , where  $v_0^{(i)}$  corresponds to  $y_{P(0)}$ ,  $v_1^{(i)}$  to  $y_{P(0)+C_{subblock}^{CC}}$ , ... and  $K_{\Pi} = (R_{subblock}^{CC} \times C_{subblock}^{CC})$

**Table 5.1.4-2 Inter-column permutation pattern for sub-block interleaver**

Number of columns $C_{subblock}^{CC}$	Inter-column permutation pattern $\langle P(0), P(1), \dots, P(C_{subblock}^{CC} - 1) \rangle$
32	$\langle 1, 17, 9, 25, 5, 21, 13, 29, 3, 19, 11, 27, 7, 23, 15, 31, 0, 16, 8, 24, 4, 20, 12, 28, 2, 18, 10, 26, 6, 22, 14, 30 \rangle$

This block interleaver is also used in interleaving PDCCH modulation symbols. In that case, the input bit sequence consists of PDCCH symbol quadruplets [2].

118. For example, and as shown below, the Samsung Galaxy A51 includes an error coding circuit comprising a rate-matching circuit for outputting a selected number of said interleaved parity bits ordered by group to obtain a desired code rate. As shown below, this functionality is described in the 4G LTE Standard, including but not limited to in 3GPP TS 36.212 §§ 5.1.4.2 and 5.1.4.2.2

**5.1.4.2 Rate matching for convolutionally coded transport channels and control information**

The rate matching for convolutionally coded transport channels and control information consists of interleaving the three bit streams,  $d_k^{(0)}$ ,  $d_k^{(1)}$  and  $d_k^{(2)}$ , followed by the collection of bits and the generation of a circular buffer as depicted in Figure 5.1.4-2. The output bits are transmitted as described in subclause 5.1.4.2.2.

**5.1.4.2.2 Bit collection, selection and transmission**

The circular buffer of length  $K_w = 3K_{\Pi}$  is generated as follows:

$$w_k = v_k^{(0)} \quad \text{for } k = 0, \dots, K_{\Pi} - 1$$

$$w_{K_{\Pi}+k} = v_k^{(1)} \quad \text{for } k = 0, \dots, K_{\Pi} - 1$$

$$w_{2K_{\Pi}+k} = v_k^{(2)} \quad \text{for } k = 0, \dots, K_{\Pi} - 1$$

Denoting by  $E$  the rate matching output sequence length, the rate matching output bit sequence is  $e_k, k = 0, 1, \dots, E - 1$ .

Set  $k = 0$  and  $j = 0$

while  $\{ k < E \}$

if  $w_{j \bmod K_w} \neq \langle NULL \rangle$

$e_k = w_{j \bmod K_w}$

$k = k + 1$

end if

$j = j + 1$

end while

119. Samsung had actual knowledge and notice of the '130 Patent no later than the filing of this Complaint and/or the date this Complaint was served upon Samsung. On information and belief, Samsung has had knowledge and notice of the '130 Patent, or should have known of the '130 Patent but were willfully blind to its existence, at least as a result of prior license agreements between Samsung and Ericsson and/or the filing of this Complaint.

120. Samsung also indirectly infringes claims of the '130 Patent, as provided in 35 U.S.C. § 271(b), by inducing infringement by others, such as Samsung's distributors, customers, and end-users, in this District and elsewhere in the United States. For example, Samsung's customers and end-users directly infringe through their use of the inventions claimed in the '130 Patent. Samsung induces this direct infringement through its affirmative acts of manufacturing, selling, distributing, and/or otherwise making available the Accused Products, and providing instructions, documentation, online technical support, marketing, product manuals, advertisements and other information to customers and end users suggesting they use the Accused Products in an infringing manner. As a result of Samsung's inducement, Samsung's customers and end users use the Accused Products in the way Samsung intends and directly infringe the '130 Patent. Samsung has performed and continues to perform these affirmative acts with knowledge of the '130 Patent and with the intent, or willful blindness, that the induced acts directly infringe the '130 Patent.

121. Samsung's infringement of the '130 Patent was willful and deliberate, entitling Ericsson to enhanced damages and attorneys' fees.

**COUNT VII: PATENT INFRINGEMENT AND DECLARATORY JUDGMENT OF  
PATENT INFRINGEMENT OF THE '239 PATENT**





122. Ericsson incorporates by reference the preceding paragraphs as though fully set forth herein.

123. Samsung infringes and/or induces infringement of at least claims 1 and 12 of the '239 Patent, either literally or under the doctrine of equivalents, by making, using, selling, offering for sale, and/or importing into the United States the Accused Products that are covered by one or more claims of the '239 Patent.

124. On information and belief, Samsung will infringe and/or induce infringement of at least claims 1 and 12 of the '239 Patent, either literally or under the doctrine of equivalents, by making, using, selling, offering for sale, and/or importing into the United States the Accused Products that are covered by one or more claims of the '239 Patent.

125. The Accused Products directly infringe one or more claims of the '239 Patent. Samsung makes, uses, sells, offers for sale, and/or imports, in this District and elsewhere in the United States the Accused Products and thus directly infringes claims of the '239 Patent.

126. For example and as shown below, the Samsung Galaxy A51 infringes claim 12 of the '239 patent by virtue of its compatibility with and practice of the 3GPP 4G LTE Standard.

Compare	 Galaxy A51 5G	 Galaxy A51	 Galaxy A71 5G	 Galaxy A21
Colors	● Prism Cube Black	● Prism Crush Black ● Prism Crush Blue ○ Prism Crush White	● Prism Cube Black	● Black
Screen size*	6.5"	6.5"	6.7"	6.5"
Internal Storage	128GB	128GB	128GB	32GB
RAM	6GB	4GB	6GB	3GB
Expandable Storage**	up to 1,000GB	up to 512GB	up to 1,000GB	up to 512GB
Cellular & Wireless***	5G, Sub 6	4G LTE	5G, Sub 6	4G LTE

<sup>5</sup> <https://www.samsung.com/us/mobile/galaxy-a51/>

127. For example, and to the extent the preamble is limiting, the Samsung Galaxy A51 is a user terminal for requesting service from a base station having a cell area where the base station offers radio communications service. |

Step 1 Samsung Galaxy A51 Teardown

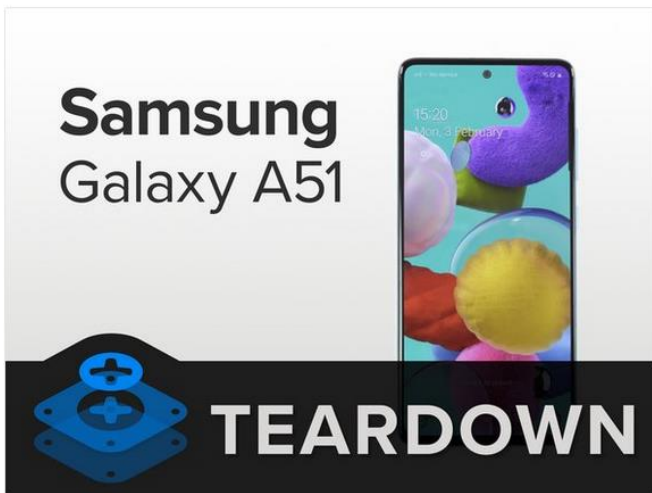

- The specs may not impress at first sight, but there's quite a lot here for the price:
  - 6.5" Super AMOLED capacitive touchscreen (1080 × 2400px) and Infinity-O Display
  - 48 MP f2.0 main camera, 12 MP f2.2 ultra wide camera, 5 MP f2.4 macro camera for close-ups and a 5 MP f2.2 depth camera for multiple live focus effects; 32 MP f2.2 front-facing camera
  - Exynos 9611, octa-core (4×2.3GHz Cortex-A73, 4×1.7GHz Cortex-A53)
  - Built-in storage: 64GB/4GB RAM, 128GB/4GB RAM, 128GB/6GB RAM
  - Android 10.0
  - Fast wired charging with 15W
  - USB-C and a nearly extinct 3.5 mm headphone jack

Step 7

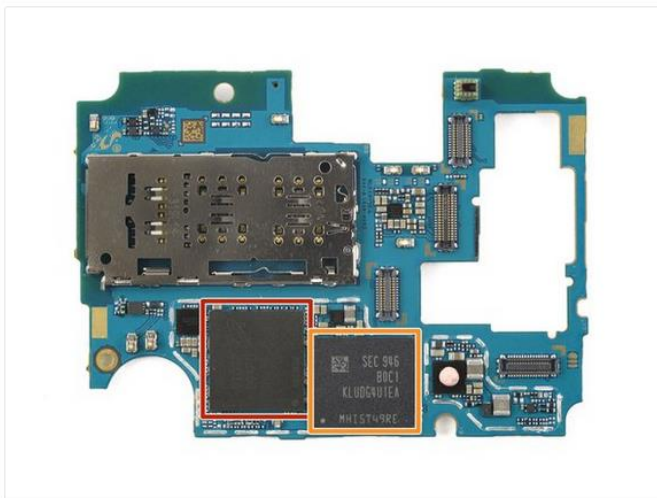

- Let's see what goodies we can find on the motherboard:
  - Micron MT53D1024M32D4BD-046 LPDDR4 memory covering the Exynos 9611, octa-core CPU with Mali-G72 MP3 GPU
  - KLUDG4U1EA-B0C1 128GB UFS 2.1 flash storage

6

128. In addition, the exemplary Samsung Galaxy A51 is configured to transmit a random access preamble using a random access channel radio resource. This functionality is

<sup>6</sup> <https://www.ifixit.com/Teardown/Samsung+Galaxy+A51+Teardown/131053>

described in the 4G LTE Standard, including but not limited to 3GPP TS 36.300 v8.12.0 (2010-03) at §10.1.5 and 3GPP TS 36.321 v8.4.0 (2008-12) at §5.1.3.

129. In addition, the exemplary Samsung Galaxy A51 is configured to receive a random access response message from the radio base station, wherein the random access response message indicates an identified radio resource and a temporary user terminal identifier indicating a scrambling sequence that is not specifically assigned to a user terminal. This functionality is described in the 4G LTE Standard, including but not limited to 3GPP TS 36.321 v8.4.0 (2008-12) at §5.1.4, 3GPP TS 36.321 v8.4.0 (2008-12) at §6.1.5, and 3GPP TS 36.300 v8.12.0 (2010-03) at §10.1.5.

130. In addition, the exemplary Samsung Galaxy A51 is configured to determine an uplink scrambling sequence based on the temporary user terminal identifier included in the random access response message. This functionality is described in the 4G LTE Standard, including but not limited to 3GPP TS 36.211 v8.9.0 (2009-12) at §5.3.1 and 3GPP TS 36 213 v.8.8.0 (2009-10) at §8.

131. In addition, the exemplary Samsung Galaxy A51 is configured to transmit a message 3 to the radio base station, wherein the message 3 includes a user terminal identity that is different from the temporary user terminal identifier, the message 3 is transmitted over the identified radio resource, and the message 3 is scrambled using the determined uplink scrambling sequence. This functionality is described in the 4G LTE Standard, including but not limited to 3GPP TS 36.300 v8.12.0 (2010-03) at §10.1.5, 3GPP TS 36 213 v.8.8.0 (2009-10) at §8, and 3GPP TS 36.321 v8.4.0 (2008-12) at §5.1.5.

132. In addition, the exemplary Samsung Galaxy A51 is configured to receive a contention-resolution message from the radio base station, which includes the user terminal

identity. This functionality is described in the 4G LTE Standard, including but not limited to 3GPP TS 36.300 v8.12.0 (2010-03) at §10.1.5 and 3GPP TS 36.321 v8.4.0 (2008-12) at §5.1.5.

133. In addition, the exemplary Samsung Galaxy A51 is configured to transmit a subsequent data transmission in the uplink scrambled with an uplink scrambling sequence based on the user terminal identity in the received contention-resolution message. This functionality is described in the 4G LTE Standard, including but not limited to 3GPP TS 36.211 v8.9.0 (2009-12) at §5.3.1 and 3GPP TS 36 213 v.8.8.0 (2009-10) at §8.

134. For further example, the Samsung Galaxy S20 5G infringes claim 12 of the '239 patent by virtue of its compatibility with and practice of the 3GPP 5G NR Standard. *See* 3GPP TS 38.300 v15.7.0 (2019-09) at § 9.2.6, 3GPP TS 38.321 v15.7.0 (2019-10) at §§ 5.1.3, 5.1.4, 5.1.5, 6.1.3, 6.2.3, 3GPP TS 38.213 v15.7.0 (2019-10) at § 8.3, 3GPP TS 38.211 v15.7.0 (2019-10) at § 6.3.

135. Samsung had actual knowledge and notice of the '239 Patent no later than the filing of this Complaint and/or the date this Complaint was served upon Samsung. On information and belief, Samsung has had knowledge and notice of the '239 Patent, or should have known of the '239 Patent but were willfully blind to its existence, at least as a result of prior license agreements between Samsung and Ericsson and/or the filing of this Complaint.

136. Samsung also indirectly infringes claims of the '239 Patent, as provided in 35 U.S.C. § 271(b), by inducing infringement by others, such as Samsung's distributors, customers, and end-users, in this District and elsewhere in the United States. For example, Samsung's customers and end-users directly infringe through their use of the inventions claimed in the '239 Patent. Samsung induces this direct infringement through its affirmative acts of manufacturing, selling, distributing, and/or otherwise making available the Accused Products, and providing

instructions, documentation, online technical support, marketing, product manuals, advertisements and other information to customers and end users suggesting they use the Accused Products in an infringing manner. As a result of Samsung's inducement, Samsung's customers and end users use the Accused Products in the way Samsung intends and directly infringe the '239 Patent. Samsung has performed and continues to perform these affirmative acts with knowledge of the '239 Patent and with the intent, or willful blindness, that the induced acts directly infringe the '239 Patent.

137. Samsung's infringement of the '239 Patent was willful and deliberate, entitling Ericsson to enhanced damages and attorneys' fees.

**COUNT VIII: PATENT INFRINGEMENT AND DECLARATORY JUDGMENT OF  
PATENT INFRINGEMENT OF THE '355 PATENT**

138. Ericsson incorporates by reference the preceding paragraphs as though fully set forth herein.





139. Samsung infringes and/or induces infringement of at least claims 17, 24, 33, and 35 of the '355 Patent, either literally or under the doctrine of equivalents, by making, using, selling, offering for sale, and/or importing into the United States the Accused Products that are covered by one or more claims of the '355 Patent.

140. On information and belief, Samsung will infringe and/or induce infringement of at least claims 17, 24, 33, and 35 of the '355 Patent, either literally or under the doctrine of equivalents, by making, using, selling, offering for sale, and/or importing into the United States the Accused Products that are covered by one or more claims of the '355 Patent.

141. The Accused Products directly infringe one or more claims of the '355 Patent. Samsung makes, uses, sells, offers for sale, and/or imports, in this District and elsewhere in the United States the Accused Products and thus directly infringes claims of the '355 Patent.



142. For example and as shown below, the Samsung Galaxy A51 infringes claim 24 of the '355 patent by virtue of its compatibility with and practice of the 3GPP 4G LTE Standard.

Compare	 Galaxy A51 5G	 Galaxy A51	 Galaxy A71 5G	 Galaxy A21
Colors	● Prism Cube Black	● Prism Crush Black ● Prism Crush Blue ○ Prism Crush White	● Prism Cube Black	● Black
Screen size*	6.5"	6.5"	6.7"	6.5"
Internal Storage	128GB	128GB	128GB	32GB
RAM	6GB	4GB	6GB	3GB
Expandable Storage**	up to 1,000GB	up to 512GB	up to 1,000GB	up to 512GB
Cellular & Wireless***	5G, Sub 6	4G LTE	5G, Sub 6	4G LTE

7

143. For example, and to the extent the preamble is limiting, the Samsung Galaxy A51 comprises user equipment comprising a baseband processor.

<sup>7</sup> <https://www.samsung.com/us/mobile/galaxy-a51/>

Step 1 Samsung Galaxy A51 Teardown

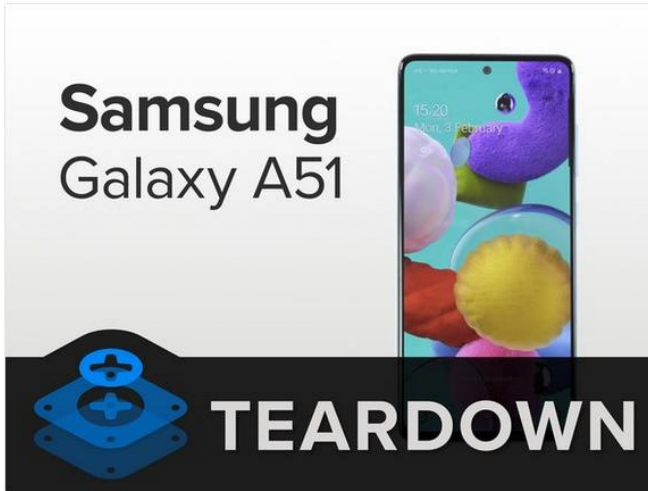

- The specs may not impress at first sight, but there's quite a lot here for the price:
  - 6.5" Super AMOLED capacitive touchscreen (1080 × 2400px) and Infinity-O Display
  - 48 MP *f*2.0 main camera, 12 MP *f*2.2 ultra wide camera, 5 MP *f*2.4 macro camera for close-ups and a 5 MP *f*2.2 depth camera for multiple live focus effects; 32 MP *f*2.2 front-facing camera
  - Exynos 9611, octa-core (4×2.3GHz Cortex-A73, 4×1.7GHz Cortex-A53)
  - Built-in storage: 64GB/4GB RAM, 128GB/4GB RAM, 128GB/6GB RAM
  - Android 10.0
  - Fast wired charging with 15W
  - USB-C and a nearly extinct 3.5 mm headphone jack

Step 7

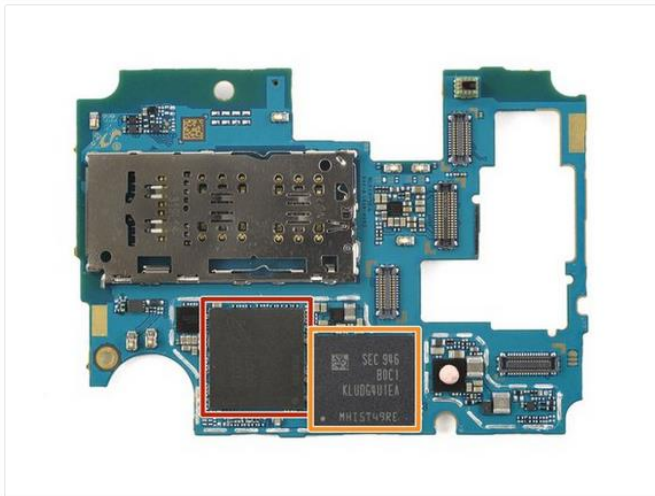

- Let's see what goodies we can find on the motherboard:
  - Micron MT53D1024M32D4BD-046 LPDDR4 memory covering the Exynos 9611, octa-core CPU with Mali-G72 MP3 GPU
  - KLUDG4U1EA-B0C1 128GB UFS 2.1 flash storage

8

144. For example, and as shown below, the Samsung Galaxy A51 monitors, by the user equipment, at least one subframe within a time window for an indication of presence of system information in the at least one subframe, the time window being one of a set of recurring

<sup>8</sup> <https://www.ifixit.com/Teardown/Samsung+Galaxy+A51+Teardown/131053>

time windows used for transmission of the system information, each of said recurring time windows spanning a number of subframes, and said indication being present in each subframe where system information is present. This functionality is described in the 4G LTE Standard, including but not limited to in 3GPP TS 36.331 v8.21.0 (2014-06) at §§ 5.2, 6.2.2.

145. For example, and as shown below, the Samsung Galaxy A51 reads by the user equipment, system information from the at least one subframe when said indication is present in the at least one subframe, wherein the indication is a System Information Radio Network Temporary Identifier (SI-RNTI). This functionality is described in the 4G LTE Standard, including but not limited to in 3GPP TS 36.331 v8.21.0 (2014-06) at § 5.2, and 3GPP TS 36.300 v8.12.0 (2010-03) at § 7.4.

146. For further example, the Samsung Galaxy S20 5G infringes claim 24 of the '355 patent by virtue of its compatibility with and practice of the 3GPP 5G NR Standard. *See, e.g.*, 3GPP TS 38.201 v15.0.0 (2017-12) at § 4.2, 3GPP TS 38.202 v15.4.0 (2018-12) at § 6.2, 3GPP TS 38.211 v15.4.0 (2018-12) at § 4.3, 3GPP TS 38.212 v15.4.0 (2018-12) at § 7.3.1.2, 3GPP TS 38.214 v15.4.0 (2018-12) at § 5.1.2, 3GPP TS 38.300 v15.4.0 (2018-12) at § 5.5, and 3GPP TS 38.331 v15.4.0 (2018-12) at §§ 5.2, 6.2, 6.3.

147. Samsung has had knowledge and notice of the '355 Patent no later than the filing of this Complaint and/or the date this Complaint was served upon Samsung. On information and belief, Samsung has had knowledge and notice of the '355 Patent, or should have known of the '355 Patent but were willfully blind to its existence, at least as a result of prior license agreements between Samsung and Ericsson and/or the filing of this Complaint.

148. Samsung also indirectly infringes claims of the '355 Patent, as provided in 35 U.S.C. § 271(b), by inducing infringement by others, such as Samsung's distributors, customers,

and end-users, in this District and elsewhere in the United States. For example, Samsung's customers and end-users directly infringe through their use of the inventions claimed in the '355 Patent. Samsung induces this direct infringement through its affirmative acts of manufacturing, selling, distributing, and/or otherwise making available the Accused Products, and providing instructions, documentation, online technical support, marketing, product manuals, advertisements and other information to customers and end users suggesting they use the Accused Products in an infringing manner. As a result of Samsung's inducement, Samsung's customers and end users use the Accused Products in the way Samsung intends and directly infringe the '355 Patent. Samsung has performed and continues to perform these affirmative acts with knowledge of the '355 Patent and with the intent, or willful blindness, that the induced acts directly infringe the '355 Patent.

149. Samsung's infringement of the '355 Patent was willful and deliberate, entitling Ericsson to enhanced damages and attorneys' fees.

**COUNT IX: PATENT INFRINGEMENT AND DECLARATORY JUDGMENT OF  
PATENT INFRINGEMENT OF THE '655 PATENT**

150. Ericsson incorporates by reference the preceding paragraphs as though fully set forth herein.

151. Samsung infringes, contributes to the infringement of, and/or induces infringement of at least claims 1, 7, 13, 17, 21, 26, 31, and 26 of the '655 Patent, either literally or under the doctrine of equivalents, by making, using, selling, offering for sale, and/or importing into the United States the Accused Products that are covered by one or more claims of the '655 Patent.

152. On information and belief, Samsung will infringe, contribute to the infringement of, and/or induce infringement of at least claims 1, 7, 13, 17, 21, 26, 31, and 26 of the '655

Patent, either literally or under the doctrine of equivalents, by making, using, selling, offering for sale, and/or importing into the United States the Accused Products that are covered by one or more claims of the '655 Patent.

153. The Accused Products directly infringe one or more claims of the '655 Patent. Samsung makes, uses, sells, offers for sale, and/or imports, in this District and elsewhere in the United States the Accused Products and thus directly infringes claims of the '655 Patent.

154. For example, the Samsung Galaxy S20 5G infringes claim 7 of the '655 Patent by virtue of its compatibility with and practice of the 3GPP 5G NR Standard and/or 3GPP 4G LTE Standard.<sup>9</sup>

## Network & Connectivity 5G

5G Non-Standalone (NSA), Standalone (SA), Sub6 / mmWave

155. For example, and to the extent the preamble is limiting, the Samsung Galaxy S20 5G, including the Snapdragon 865 and X55 5G Modem, comprises a wireless terminal and further comprises a transceiver configured to provide radio communications with a wireless communication network over a radio interface and a processor coupled with the transceiver. *See, e.g.,* Galaxy S20 | S20+ | S20 Ultra 5G, Samsung, <https://image-us.samsung.com/SamsungUS/samsungbusiness/pdfs/datasheet/HHP-UNLOCKED-S20SERIESDSHT-FEB20T-2-26-20.pdf>; Snapdragon 865 5G Mobile Platform, Qualcomm, <https://www.qualcomm.com/products/snapdragon-865-5g-mobile-platform>.

156. For example, the Samsung Galaxy S20 5G comprises a processor configured to receive a first Medium Access Control (MAC) Control Element (CE) through the transceiver

---

<sup>9</sup> *Galaxy S20 FE 5G | S20 5G | S20+ 5G | S20 Ultra 5G: Specifications*, Samsung, <https://www.samsung.com/us/mobile/galaxy-s20-5g/specs/>

from the wireless communication network, wherein the first MAC CE includes a first bit map having a first bit map size with bits of the first bit map corresponding to respective component carriers of a first group of component carriers and indicating an activation status of the respective component carriers of the first group. This functionality is described in the 5G NR Standard, including, but not limited to, in 3GPP TS 38.321 §§ 4.1, 5.9, 6.1.3.10, 6.2.1. Additionally, this functionality is described in the 4G LTE Standard, including, but not limited to, in 3GPP TS 36.321 §§ 4.1, 5.13, 6.1.3.8, 6.2.1.

157. Additionally, for example, the Samsung Galaxy S20 5G comprises a processor configured to receive a second MAC CE through the transceiver from the wireless communication network, wherein the second MAC CE includes a second bit map having a second bit map size with bits of the second bit map corresponding to respective component carriers of a second group of component carriers and indicating an activation status of the respective component carriers of the second group, and wherein the first bit map size of the first bit map is different than the second bit map size of the second bit map. This functionality is described in the 5G NR Standard, including, but not limited to, in 3GPP TS 38.321 §§ 4.1, 5.9, 6.1.3.10 and 6.2.1. Additionally, this functionality is described in the 4G LTE Standard, including, but not limited to, in 3GPP TS 36.321 §§ 4.1, 5.13, 6.1.3.8, 6.2.1.

158. For further example, the Base Station Accused Products infringe at least claims 13, 17, 31, and 36 of the '655 Patent by virtue of their compatibility with and practice of the 3GPP 5G NR Standard and/or 3GPP 4G LTE Standard. *See* 3GPP TS 38.300 § 4; 3GPP TS 38.321 § 4.1, 5.9, 6.1.3.10, 6.2.1; 3GPP TS 36.300 § 4; 3GPP TS 36.321 §§ 4.1, 5.13, 6.1.3.8, 6.2.1.

159. Samsung has had knowledge and notice of the '655 Patent no later than the filing of this Complaint and/or the date this Complaint was served upon Samsung. On information and belief, Samsung has had knowledge and notice of the '655 Patent, or should have known of the '655 Patent but were willfully blind to its existence, at least as a result of prior license agreements between Samsung and Ericsson and/or the filing of this Complaint.

160. Samsung also indirectly infringes claims of the '655 Patent, as provided in 35 U.S.C. § 271(b), by inducing infringement by others, such as Samsung's distributors, customers, and end-users, in this District and elsewhere in the United States. For example, Samsung's customers and end-users directly infringe through their use of the inventions claimed in the '655 Patent. Samsung induces this direct infringement through its affirmative acts of manufacturing, selling, distributing, and/or otherwise making available the Accused Products, and providing instructions, documentation, online technical support, marketing, product manuals, advertisements and other information to customers and end users suggesting they use the Accused Products in an infringing manner. As a result of Samsung's inducement, Samsung's customers and end users use the Accused Products in the way Samsung intends and directly infringe the '655 Patent. Samsung has performed and continues to perform these affirmative acts with knowledge of the '655 Patent and with the intent, or willful blindness, that the induced acts directly infringe the '655 Patent.

161. Samsung also indirectly infringes claims of the '655 Patent, as provided by 35 U.S.C. § 271(c), by contributing to direct infringement committed by others, such as customers and end-users, in this District and elsewhere in the United States. Samsung's affirmative acts of selling and offering to sell, in this District and elsewhere in the United States, the Accused Products and causing the Accused Products to be manufactured, used, sold, and

offered for sale, contribute to Samsung's customers and end-users use of the Accused Products, such that the '655 Patent is directly infringed. The accused components within the Accused Products are material to the invention of the '655 Patent, are not staple articles or commodities of commerce, have no substantial non-infringing uses, and are known by Samsung to be especially made or especially adapted for use in infringement of the '655 Patent. Samsung has performed and continues to perform these affirmative acts with knowledge of the '655 Patent and with intent, or willful blindness, that they cause the direct infringement of the '655 Patent.

162. Samsung's infringement of the '655 Patent was willful and deliberate, entitling Ericsson to enhanced damages and attorneys' fees.

**COUNT X: PATENT INFRINGEMENT AND DECLARATORY JUDGMENT OF  
PATENT INFRINGEMENT OF THE '600 PATENT**

163. Ericsson incorporates by reference the preceding paragraphs as though fully set forth herein.

164. Samsung infringes, contributes to the infringement of, and/or induces infringement of at least claims 1, 8, 15, and 22 of the '600 Patent, either literally or under the doctrine of equivalents, by making, using, selling, offering for sale, and/or importing into the United States the Accused Products that are covered by one or more claims of the '600 Patent.

165. On information and belief, Samsung will infringe, contribute to the infringement of, and/or induce infringement of at least claims 1, 8, 15, and 22 of the '600 Patent, either literally or under the doctrine of equivalents, by making, using, selling, offering for sale, and/or importing into the United States the Accused Products that are covered by one or more claims of the '600 Patent.



166. The Accused Products directly infringe one or more claims of the '600 Patent. Samsung makes, uses, sells, offers for sale, and/or imports, in this District and elsewhere in the United States the Accused Products and thus directly infringes claims of the '600 Patent.

167. For example, the Samsung Galaxy S20 5G infringes claim 22 of the '600 Patent by virtue of its compatibility with and practice of the 3GPP 5G NR Standard.<sup>10</sup>

## Network & Connectivity 5G

5G Non-Standalone (NSA), Standalone (SA), Sub6 / mmWave

168. For example, and to the extent the preamble is limiting, the Samsung Galaxy S20 5G, including the Snapdragon 865 and X55 5G Modem, is a wireless communication device for decoding signaling from a network node indicating which precoders in a codebook are restricted from being used further comprising a processor and a memory, the memory containing instructions executable by the processor. *See, e.g.*, Galaxy S20 | S20+ | S20 Ultra 5G, Samsung, <https://image-us.samsung.com/SamsungUS/samsungbusiness/pdfs/datasheet/HHP-UNLOCKED-S20SERIESDSHT-FEB20T-2-26-20.pdf>; Snapdragon 865 5G Mobile Platform, Qualcomm, <https://www.qualcomm.com/products/snapdragon-865-5g-mobile-platform>.

169. For example, the Samsung Galaxy S20 5G is configured to receive codebook subset restriction signaling that, for each of one or more groups of precoders, jointly restricts the precoders in the group by restricting a certain component that the precoders in the group have in common. This functionality is described in the 5G NR Standard, including, but not limited to, in 3GPP TS 38.214 at § 5.2.2.2 and 3GPP TS 38.331 §§ 5.3.5 and 6.3.2.

---

<sup>10</sup> *Galaxy S20 FE 5G | S20 5G | S20+ 5G | S20 Ultra 5G: Specifications*, Samsung, <https://www.samsung.com/us/mobile/galaxy-s20-5g/specs/>

170. Additionally, for example, the Samsung Galaxy S20 5G is configured to receive codebook subset restriction signaling that is rank-agnostic signaling that jointly restricts the precoders in a group without regard to the precoders' transmission rank. This functionality is described in the 5G NR Standard, including, but not limited to, in 3GPP TS 38.214 at § 5.2.2.2.

171. Additionally, for example, the Samsung Galaxy S20 5G is configured to decode the received signaling as jointly restricting precoders in each of the one or more groups of precoders. This functionality is described in the 5G NR Standard, including, but not limited to, in 3GPP TS 38.331 §§ 5.3.5 and 6.3.2.

172. For further example, the Base Station Accused Products infringe at least claim 15 of the '600 patent by virtue of their compatibility with and practice of the 3GPP 5G NR Standard. *See* 3GPP TS 38.214 at § 5.2.2.2 and 3GPP TS 38.331 §§ 5.3.5 and 6.3.2.

173. Samsung has had knowledge and notice of the '600 Patent no later than the filing of this Complaint and/or the date this Complaint was served upon Samsung. On information and belief, Samsung has had knowledge and notice of the '600 Patent, or should have known of the '600 Patent but were willfully blind to its existence, at least as a result of prior license agreements between Samsung and Ericsson and/or the filing of this Complaint.

174. Samsung also indirectly infringes claims of the '600 Patent, as provided in 35 U.S.C. § 271(b), by inducing infringement by others, such as Samsung's distributors, customers, and end-users, in this District and elsewhere in the United States. For example, Samsung's customers and end-users directly infringe through their use of the inventions claimed in the '600 Patent. Samsung induces this direct infringement through its affirmative acts of manufacturing, selling, distributing, and/or otherwise making available the Accused Products, and providing instructions, documentation, online technical support, marketing, product manuals,

advertisements and other information to customers and end users suggesting they use the Accused Products in an infringing manner. As a result of Samsung's inducement, Samsung's customers and end users use the Accused Products in the way Samsung intends and directly infringe the '600 Patent. Samsung has performed and continues to perform these affirmative acts with knowledge of the '600 Patent and with the intent, or willful blindness, that the induced acts directly infringe the '600 Patent.

175. Samsung also indirectly infringes claims of the '600 Patent, as provided by 35 U.S.C. § 271(c), by contributing to direct infringement committed by others, such as customers and end-users, in this District and elsewhere in the United States. Samsung's affirmative acts of selling and offering to sell, in this District and elsewhere in the United States, the Accused Products and causing the Accused Products to be manufactured, used, sold, and offered for sale, contribute to Samsung's customers and end-users use of the Accused Products, such that the '600 Patent is directly infringed. The accused components within the Accused Products are material to the invention of the '600 Patent, are not staple articles or commodities of commerce, have no substantial non-infringing uses, and are known by Samsung to be especially made or especially adapted for use in infringement of the '600 Patent. Samsung has performed and continues to perform these affirmative acts with knowledge of the '600 Patent and with intent, or willful blindness, that they cause the direct infringement of the '600 Patent.

176. Samsung's infringement of the '600 Patent was willful and deliberate, entitling Ericsson to enhanced damages and attorneys' fees.

**COUNT XI: PATENT INFRINGEMENT AND DECLARATORY JUDGMENT OF  
PATENT INFRINGEMENT OF THE '817 PATENT**

177. Ericsson incorporates by reference the preceding paragraphs as though fully set forth herein.

178. Samsung infringes, contributes to the infringement of, and/or induces infringement of at least claims 1, 9, 10, and 15 of the '817 Patent, either literally or under the doctrine of equivalents, by making, using, selling, offering for sale, and/or importing into the United States the Accused Products that are covered by one or more claims of the '817 Patent.

179. On information and belief, Samsung will infringe, contribute to the infringement of, and/or induce infringement of at least claims 1, 9, 10, and 15 of the '817 Patent, either literally or under the doctrine of equivalents, by making, using, selling, offering for sale, and/or importing into the United States the Accused Products that are covered by one or more claims of the '817 Patent.

180. The Accused Products directly infringe one or more claims of the '817 Patent. Samsung makes, uses, sells, offers for sale, and/or imports, in this District and elsewhere in the United States the Accused Products and thus directly infringes claims of the '817 Patent.

181. For example, the Samsung Galaxy S20 5G infringes claim 15 of the '817 Patent by virtue of its compatibility with and practice of the 3GPP 5G NR Standard.<sup>11</sup>

## Network & Connectivity      5G

5G Non-Standalone (NSA), Standalone (SA), Sub6 / mmWave

182. For example, and to the extent the preamble is limiting, the Samsung Galaxy S20 5G comprises a user equipment (UE) for concealing a subscription permanent identifier (SUPI), wherein the SUPI is a globally unique identifier allocated to a subscriber and the SUPI comprises a home network identifier identifying a home network of the subscriber and a subscription identifier identifying a subscription within the home network. The UE includes the Snapdragon

---

<sup>11</sup> *Galaxy S20 FE 5G | S20 5G | S20+ 5G | S20 Ultra 5G: Specifications*, Samsung, <https://www.samsung.com/us/mobile/galaxy-s20-5g/specs/>.

865 and X55 5G Modem and comprises processing circuitry and memory circuitry, the memory circuitry containing instructions executable by the processing circuitry. *See, e.g.*, Galaxy S20 | S20+ | S20 Ultra 5G, Samsung, <https://image-us.samsung.com/SamsungUS/samsungbusiness/pdfs/datasheet/HHP-UNLOCKED-S20SERIESDSHT-FEB20T-2-26-20.pdf>; Snapdragon 865 5G Mobile Platform, Qualcomm, <https://www.qualcomm.com/products/snapdragon-865-5g-mobile-platform>. This functionality is described in the 5G NR Standard, including, but not limited to, in 3GPP TS 33.501 §§ 3.1, 3.2, and 6.12, 3GPP TS 23.501 § 5.9, and 3GPP TS 23.003 § 2.2 (all including respective subsections).

183. For example, the Samsung Galaxy S20 5G comprises a UE that is operative to generate a subscription concealed identifier (SUCI) which comprises an encrypted part and a clear-text part, wherein a) the encrypted part of the SUCI generated by the UE comprises the subscription identifier identifying the subscription within a home network, but the encrypted part of the SUCI generated by the UE does not include the home network identifier and b) the clear-text part of the SUCI generated by the UE comprises i) the home network identifier, ii) an encryption scheme identifier that identifies an encryption scheme used by the UE to encrypt the subscription identifier in the SUCI, and iii) a public key identifier for a public key of the home network, but the clear-text part of the SUCI generated by the UE does not comprise the subscription identifier. This functionality is described in the 5G NR Standard, including, but not limited to, in 3GPP TS 33.501 §§ 5.2, 6.12, and Annex C and 3GPP TS 23.003 § 2.2B (all including respective subsections).

184. Additionally, for example, the Samsung Galaxy S20 5G comprises a UE that is operative to transmit the SUCI to an authentication server for forwarding of the SUCI to a de-

concealing server capable of decrypting the SUPI. This functionality is described in the 5G NR Standard, including, but not limited to, in 3GPP TS 33.501 §§ 3.2, 5.6, 6.1, and 6.12 (all including respective subsections).

185. For further example, the Core Network Accused Products infringe at least claims 1 and 9 of the '817 Patent by virtue of their compatibility with and practice of the 3GPP 5G NR Standard. *See* 3GPP TS 33.501 §§ 3.1, 3.2, 5.2, 6.1, 6.12, and Annex C, 3GPP TS 23.003 §§ 2.2 and 2.2B, and 3GPP TS 23.501 §§ 5.9 and 6.3 (all including respective subsections).

186. Samsung has had knowledge and notice of the '817 Patent no later than the filing of this Complaint and/or the date this Complaint was served upon Samsung. On information and belief, Samsung has had knowledge and notice of the '817 Patent, or should have known of the '817 Patent but were willfully blind to its existence, at least as a result of prior license agreements between Samsung and Ericsson and/or the filing of this Complaint.

187. Samsung also indirectly infringes claims of the '817 Patent, as provided in 35 U.S.C. § 271(b), by inducing infringement by others, such as Samsung's distributors, customers, and end-users, in this District and elsewhere in the United States. For example, Samsung's customers and end-users directly infringe through their use of the inventions claimed in the '817 Patent. Samsung induces this direct infringement through its affirmative acts of manufacturing, selling, distributing, and/or otherwise making available the Accused Products, and providing instructions, documentation, online technical support, marketing, product manuals, advertisements and other information to customers and end users suggesting they use the Accused Products in an infringing manner. As a result of Samsung's inducement, Samsung's customers and end users use the Accused Products in the way Samsung intends and directly infringe the '817 Patent. Samsung has performed and continues to perform these affirmative acts

with knowledge of the '817 Patent and with the intent, or willful blindness, that the induced acts directly infringe the '817 Patent.

188. Samsung also indirectly infringes claims of the '817 Patent, as provided by 35 U.S.C. § 271(c), by contributing to direct infringement committed by others, such as customers and end-users, in this District and elsewhere in the United States. Samsung's affirmative acts of selling and offering to sell, in this District and elsewhere in the United States, the Accused Products and causing the Accused Products to be manufactured, used, sold, and offered for sale, contribute to Samsung's customers and end-users use of the Accused Products, such that the '817 Patent is directly infringed. The accused components within the Accused Products are material to the invention of the '817 Patent, are not staple articles or commodities of commerce, have no substantial non-infringing uses, and are known by Samsung to be especially made or especially adapted for use in infringement of the '817 Patent. Samsung has performed and continues to perform these affirmative acts with knowledge of the '817 Patent and with intent, or willful blindness, that they cause the direct infringement of the '817 Patent.

189. Samsung's infringement of the '817 Patent was willful and deliberate, entitling Ericsson to enhanced damages and attorneys' fees.

**COUNT XII: PATENT INFRINGEMENT AND DECLARATORY JUDGMENT OF  
PATENT INFRINGEMENT OF THE '513 PATENT**

190. Ericsson incorporates by reference the preceding paragraphs as though fully set forth herein.

191. Samsung infringes, contributes to the infringement of, and/or induces infringement of at least claims 1, 10, and 18 of the '513 Patent, either literally or under the doctrine of equivalents, by making, using, selling, offering for sale, and/or importing into the United States the Accused Products that are covered by one or more claims of the '513 Patent.

192. On information and belief, Samsung will infringe, contribute to the infringement of, and/or induce infringement of at least claims 1, 10, and 18 of the '513 Patent, either literally or under the doctrine of equivalents, by making, using, selling, offering for sale, and/or importing into the United States the Accused Products that are covered by one or more claims of the '513 Patent.

193. The Accused Products directly infringe one or more claims of the '513 Patent. Samsung makes, uses, sells, offers for sale, and/or imports, in this District and elsewhere in the United States the Accused Products and thus directly infringes claims of the '513 Patent.

194. For example, the Samsung Galaxy S20 5G infringes claim 18 of the '513 Patent by virtue of its compatibility with and practice of the 3GPP 5G NR Standard.<sup>12</sup>

#### Network & Connectivity      5G

5G Non-Standalone (NSA), Standalone (SA), Sub6 / mmWave

195. For example, and to the extent the preamble is limiting, the Samsung Galaxy S20 5G comprises user equipment, including the Snapdragon 865 and X55 5G Modem, further comprising an antenna, processing circuitry, and a transceiver connected to the antenna and to the processing circuitry and configured to condition signals communicated between the antenna and the processing circuitry. *See, e.g., Galaxy S20 | S20+ | S20 Ultra 5G*, SAMSUNG, <https://image-us.samsung.com/SamsungUS/samsungbusiness/pdfs/datasheet/HHP-UNLOCKED-S20SERIESDSHT-FEB20T-2-26-20.pdf>; *Snapdragon 865 5G Mobile Platform*, QUALCOMM, <https://www.qualcomm.com/products/snapdragon-865-5g-mobile-platform>.

---

<sup>12</sup> *Galaxy S20 FE 5G | S20 5G | S20+ 5G | S20 Ultra 5G: Specifications*, Samsung, <https://www.samsung.com/us/mobile/galaxy-s20-5g/specs/>



196. For example, the Samsung Galaxy S20 5G comprises processing circuitry configured to receive an indication from a network node of a combination of a plurality of components contained in one or more physical resource blocks of a slot. This functionality is described in the 5G NR Standard, including, but not limited to, in 3GPP TS 38.211 §§ 4.4.3 and 4.4.4 and 3GPP TS 38.214 § 5.2.2.3.

197. Additionally, for example, the Samsung Galaxy S20 5G comprises processing circuitry configured to use the indicated combination of the plurality of components for a reference signal resource, wherein the physical resource block spans a plurality of subcarriers, and wherein indicating the combination of the plurality of components includes indicating one or more subcarrier indexes. This functionality is described in the 5G NR Standard, including, but not limited to, in 3GPP TS 38.211 §§ 4.4.3, 4.4.4, 7.3.1, 7.4.1; 3GPP TS 38.214 §§ 5.2.2.3, 7.4.1.5, Table 7.4.1.5.3-1; and 3GPP TS 38.331 § 6.3.2.

198. Additionally, for example, for the Samsung Galaxy S20 5G, the indication of the one or more subcarrier indexes includes a bitmap, and each bit in the bitmap uniquely corresponds to a subcarrier index and a set bit in the bitmap indicates that a component located at a subcarrier index corresponding to the set bit is part of the combination of a plurality of components used for the reference signal resource. This functionality is described in the 5G NR Standard, including, but not limited to, in 3GPP TS 38.211 §§ 4.4.3, 4.4.4, 7.3.1, 7.4.1; 3GPP TS 38.214 §§ 5.2.2.3, 7.4.1.5, Table 7.4.1.5.3-1; and 3GPP TS 38.331 § 6.3.2.

199. For further example, the Samsung Base Station Accused Products are used to infringe at least claim 1 of the '513 Patent by virtue of their compatibility with and practice of the 3GPP 5G NR Standard. *See, e.g.*, 3GPP TS 38.211 §§ 4.4.3, 4.4.4, 7.3.1, 7.4.1; 3GPP TS 38.214 §§ 5.2.2.3, 7.4.1.5, Table 7.4.1.5.3-1; and 3GPP TS 38.331 § 6.3.2.

200. Samsung has had knowledge and notice of the '513 Patent no later than the filing of this Complaint and/or the date this Complaint was served upon Samsung. On information and belief, Samsung has had knowledge and notice of the '513 Patent, or should have known of the '513 Patent but were willfully blind to its existence, at least as a result of prior license agreements between Samsung and Ericsson and/or the filing of this Complaint.

201. Samsung also indirectly infringes claims of the '513 Patent, as provided in 35 U.S.C. § 271(b), by inducing infringement by others, such as Samsung's distributors, customers, and end-users, in this District and elsewhere in the United States. For example, Samsung's customers and end-users directly infringe through their use of the inventions claimed in the '513 Patent. Samsung induces this direct infringement through its affirmative acts of manufacturing, selling, distributing, and/or otherwise making available the Accused Products, and providing instructions, documentation, online technical support, marketing, product manuals, advertisements and other information to customers and end users suggesting they use the Accused Products in an infringing manner. As a result of Samsung's inducement, Samsung's customers and end users use the Accused Products in the way Samsung intends and directly infringe the '513 Patent. Samsung has performed and continues to perform these affirmative acts with knowledge of the '513 Patent and with the intent, or willful blindness, that the induced acts directly infringe the '513 Patent.

202. Samsung also indirectly infringes claims of the '513 Patent, as provided by 35 U.S.C. § 271(c), by contributing to direct infringement committed by others, such as customers and end-users, in this District and elsewhere in the United States. Samsung's affirmative acts of selling and offering to sell, in this District and elsewhere in the United States, the Accused Products and causing the Accused Products to be manufactured, used, sold, and offered for sale,

contribute to Samsung's customers and end-users use of the Accused Products, such that the '513 Patent is directly infringed. The accused components within the Accused Products are material to the invention of the '513 Patent, are not staple articles or commodities of commerce, have no substantial non-infringing uses, and are known by Samsung to be especially made or especially adapted for use in infringement of the '513 Patent. Samsung has performed and continues to perform these affirmative acts with knowledge of the '513 Patent and with intent, or willful blindness, that they cause the direct infringement of the '513 Patent.

203. Samsung's infringement of the '513 Patent was willful and deliberate, entitling Ericsson to enhanced damages and attorneys' fees.

#### **PRAAYER FOR RELIEF**

WHEREFORE, Ericsson respectfully requests that this Court enter judgment in its favor as follows and award Ericsson the following relief:

- (a) adjudge and declare that Samsung did not satisfy its reciprocity obligations or otherwise comply with its FRAND commitment in its negotiations with Ericsson in regard to a cross-license to the parties' Essential Patents;
- (b) adjudge and declare that Samsung breached its duty to negotiate with Ericsson in good faith, in breach of its obligations under the ETSI IPR Policy;
- (c) adjudge and declare that Samsung has repudiated and forfeited its right to enforce Ericsson's FRAND commitment under the ETSI IPR Policy as a third-party beneficiary;
- (d) adjudge and declare that Ericsson's offer complies with FRAND, that Ericsson fully complied with its FRAND commitment and all other applicable laws in its negotiations with Samsung in regard to a cross-license to the parties' Essential Patents, and that Ericsson fully complied with the ETSI IPR Policy in all respects;
- (e) adjudge and declare that Samsung infringes the Asserted Patents;
- (f) adjudge and declare that Samsung's infringement of the Asserted Patents was willful, and that Samsung's continued infringement of the Asserted Patents is willful;

- (g) an award of the amount of damages that Ericsson proves at trial and, as appropriate, exemplary damages;
- (h) an award of enhanced damages pursuant to 35 U.S.C. § 284;
- (i) enter an order finding that this is an exceptional case and awarding Ericsson its reasonable attorneys' fees pursuant to 35 U.S.C. § 285;
- (j) order an accounting of damages
- (k) specific performance requiring Samsung make available to Ericsson a license to all of its Essential Patents on FRAND terms;
- (l) the costs of this action, including attorneys' fees; and
- (m) pre-judgment and post-judgment interest at the maximum amount permitted by law.

Dated: January 1, 2021

**McKool Smith, P.C.**

*/s/ Theodore Stevenson, III*

Theodore Stevenson, III, Lead Attorney

Texas State Bar No. 19196650

tstevenson@mckoolsmith.com

Nicholas Mathews

Texas State Bar No. 24085457

nmathews@mckoolsmith.com

**McKool Smith, P.C.**

300 Crescent Court, Suite 1500

Dallas, TX 75201

Telephone: (214) 978-4000

Telecopier: (214) 978-4044

Christine Woodin

Texas State Bar No. 24199951

California Bar No. 295023

cwoodin@mckoolsmith.com

**McKool Smith, P.C.**

300 South Grand Avenue, Suite 2900

Los Angeles, California 90071

Telephone: (213) 694-1200

Telecopier: (213) 694-1234

Blake Bailey

Texas State Bar No. 24069329

bbailey@mckoolsmith.com

**McKool Smith, P.C.**

600 Travis Street, Suite 7000

Houston, TX 77002

Telephone: (713) 485-7300

Telecopier: (713) 485-7344

Samuel F. Baxter

Texas State Bar No. 01938000

sbaxter@mckoolsmith.com

Jennifer Truelove

Texas State Bar No. 24012906

jtruelove@mckoolsmith.com

**McKool Smith, P.C.**

104 E. Houston Street, Suite 300

Marshall, TX 75670

Telephone: (903) 923-9000

Telecopier: (903) 923-9099

**ATTORNEYS FOR PLAINTIFFS  
ERICSSON INC. AND  
TELEFONAKTIEBOLAGET LM  
ERICSSON**