

**IN THE UNITED STATES DISTRICT COURT  
FOR THE WESTERN DISTRICT OF TEXAS  
WACO DIVISION**

OPTIC153 LLC,

Plaintiff,

v.

AT&T INC., AT&T SERVICES, INC., AND  
AT&T COMMUNICATIONS OF TEXAS,  
LLC

Defendants.

**Civil Action No. 6:21-cv-88**

**JURY TRIAL DEMANDED**

**COMPLAINT FOR PATENT INFRINGEMENT**

Plaintiff Optic153 LLC (“Plaintiff” or “Optic153”) hereby alleges as follows against AT&T Inc., AT&T Services, Inc., and AT&T Communications of Texas, LLC ( “AT&T” or “Defendant”):

**NATURE OF THE ACTION**

1. This is an action for patent infringement arising under the Patent Laws of the United States, 35 U.S.C. § 1 *et seq.*

**THE PARTIES**

2. Plaintiff is a limited liability companies organized under the laws of the State of Delaware and has a place of business at 356 Greenwood Court, Villanova, PA, 19085.

3. Defendant AT&T Inc. is a Delaware corporation with a regular and established place of business at 1010 N. Saint Mary’s St., San Antonio, TX 78215-2109. Defendant AT&T Inc. may be served through its registered agent, CT Corporation System, 1999 Bryan St., Ste. 900, Dallas, TX 75201.

4. Defendant AT&T Services, Inc. (“AT&T Services”) is a Delaware corporation with a regular and established place of business at 1010 N. Saint Mary’s St., San Antonio, TX 78215-2109. Defendant AT&T Services was formerly known as SBC Services, Inc., and is a wholly owned subsidiary of AT&T Inc. Defendant AT&T Services may be served through its registered agent, CT Corporation System, 1999 Bryan St., Ste. 900, Dallas, TX 75201.

5. Upon information and belief, Defendant AT&T Communications of Texas, LLC (“AT&T Communications of Texas”) is a Delaware limited liability company with a regular and established place of business at 1010 N. Saint Mary’s St., San Antonio, TX 78215-2109. AT&T Communications of Texas may be served through its registered agent, CT Corporation System, 1999 Bryan St., Ste. 900, Dallas, TX 75201. On information and belief, AT&T Communications of Texas is a wholly owned subsidiary of AT&T, Inc.

6. Defendants AT&T Inc., AT&T Services, and AT&T Communications of Texas (collectively, “AT&T” or “Defendant”) operate and/or employ, or have operated or employed, either directly or indirectly, optical communications networks that utilize EDFAs and/or Raman amplifiers to controllably produce Raman amplification, attenuation and/or lossless transmission in said networks.

7. The optical communications networks operated and/or employed by AT&T have deployed at least Cisco’s Network Convergence system (e.g., NCS 2000) and/or multiservice platforms (e.g., ONS 15454) as well as Fujitsu’s ROADM systems and devices (e.g., Flashwave 7500 and 1Finity platforms) in addition to other components that are connected to these devices for the purpose of transmitting voice and data traffic. *See* “AT&T Boosts Ciena, Cisco,” *available at* <https://www.lightreading.com/ethernet-ip/atandt-boosts-ciena-cisco/d/d-id/578237> (last visited Apr. 1, 2020); *see also* “AT&T Fiber & high-speed Internet services in Cisco,”

available at <https://www.att.com/local/internet/texas/cisco> (last visited Nov. 30, 2020); *see also* “Cisco Network Convergence System 2000 Series Data Sheet,” available at [https://www.cisco.com/c/en/us/products/collateral/optical-networking/network-convergence-system-2000-series/data\\_sheet\\_c78-729221.html](https://www.cisco.com/c/en/us/products/collateral/optical-networking/network-convergence-system-2000-series/data_sheet_c78-729221.html) (last visited Apr. 1, 2020) (“Customer-specific requirements ° AT&T Network Equipment Development Standards (NEDS) Generic Requirements, AT&T 802-900-260”); *see also* “Cisco Transport Node Controller and Transport Shelf Controller Cards,” available at <https://www.andovercg.com/datasheets/cisco-transport-node-controller-and-transport-shelf-controller-cards-datasheet.pdf> (last visited Apr. 1, 2020) (“Tables 3 and 4 outline the specifications for the Cisco ONS 15454 TNC, TSC, TNCE, TSCE, NCS 2000 Series TNCS and TNCS-O cards . . . Customer requirements AT&T Network Equipment Design Specification (NEDS)”); *see also* “Fujitsu adds 40-Gbps interfaces to ROADM,” available at <https://www.lightwaveonline.com/network-design/article/16667055/fujitsu-adds-40gbps-interfaces-to-roadm> (last visited Apr. 1, 2020).

8. The optical communications networks operated and/or employed by AT&T utilize the functionality of the foregoing systems and devices in a manner designed to facilitate the transmission and reception of voice and data during the normal operation of such networks.

#### **JURISDICTION AND VENUE**

9. This is an action for patent infringement arising under the Patent Laws of the United States, 35 U.S.C. § 1, *et seq.*

10. This Court has subject matter jurisdiction under 28 U.S.C. §§ 1331 and 1338(a).

11. The Court has personal jurisdiction over AT&T at least because AT&T has continuous business contacts in the State of Texas and in this District. AT&T has engaged in business activities including transacting business in this District and purposefully directing its

business activities, including the provision of infringing communications networks and services, in this District, and the sale or offer for sale of services and goods in this District. For example, AT&T—either directly or through those acting on its behalf—offers infringing communications networks and services in this District (e.g., <https://www.att.com/shop/internet/gigapower/coverage-map.html>).

12. As another example, AT&T—either directly or through those acting on its behalf—has retail stores, and/or authorized retailers in this District in which infringing communications networks and services are offered for sale. *See, e.g.*, <https://www.att.com/stores/?q=31.5493,-97.1467&qp=Waco,%20Texas,%20United%20States&r=50&l=en>. For example, AT&T has established place of business at 1010 N. Saint Mary's St, San Antonio, TX 78215-2109, and numerous retail stores including those at 4330 W. Waco Drive, Waco, TX 76710 ; 1428 Wooded Acres Dr #120, Waco, TX 76710; and 2320 W Loop 340 #100A, Waco, TX 76711. AT&T also offers voice and data services to Texas state agencies. *See, e.g.*, <https://dir.texas.gov/View-About-DIR/Telecom/Pages/Content.aspx?id=9>

13. Venue is proper in this District under 28 U.S.C. §§ 1391(b)-(d) and 1400(b). Defendant AT&T is registered to do business in the State of Texas, has offices in the State of Texas, has transacted business in the Western District of Texas, and has committed acts of direct and indirect infringement in the Western District of Texas.

14. Venue is proper in this District pursuant to 28 U.S.C. § 1400(b). On information and belief, AT&T maintains a regular and established place of business in this District, including by maintaining or controlling offices and retail stores in this District and by maintaining and operating optical communications networks in this District, including on cellular towers and

other installation sites owned or leased by AT&T. Also, AT&T is engaged in activities including: transacting business in this district and purposefully directing its business activities, including the installation, maintenance, and use of infringing communications networks, services, and other technologies in this District, and the sale or offer for sale of services and goods to this District to aid, abet, or contribute to the infringement of third parties in this District.

**THE ASSERTED PATENTS**

15. On September 5, 2000, the USPTO duly and legally issued U.S. Patent No. 6,115,174 (“the ’174 Patent”), entitled “Optical Signal Varying Devices.” A copy of the ’174 Patent is attached hereto as Exhibit 1.

16. Optic153 owns all substantial right, title, and interest in the ’174 Patent, and holds the right to sue and recover damages for infringement thereof, including past infringement.

17. On May 22, 2001, the USPTO duly and legally issued U.S. Patent No. 6,236,487 (“the ’487 Patent”), entitled “Optical Communication Control System.” A copy of the ’487 Patent is attached hereto as Exhibit 2.

18. Optic153 owns all substantial right, title, and interest in the ’487 Patent, and holds the right to sue and recover damages for infringement thereof, including past infringement.

19. On Feb. 5, 2002, the USPTO duly and legally issued U.S. Patent No. 6,344,922 (“the ’922 Patent”), entitled “Optical Signal Varying Devices.” A copy of the ’922 Patent is attached hereto as Exhibit 3.

20. Optic153 owns all substantial right, title, and interest in the ’922 Patent, and holds the right to sue and recover damages for infringement thereof, including past infringement.

21. On Mar. 12, 2002, the USPTO duly and legally issued U.S. Patent No. 6,356,383 (“the ’383 Patent”), entitled “Optical Transmission Systems Including Optical Amplifiers Apparatuses and Methods.” A copy of the ’383 Patent is attached hereto as Exhibit 4.

22. Optic153 owns all substantial right, title, and interest in the ’383 Patent, and holds the right to sue and recover damages for infringement thereof, including past infringement.

23. On Jul. 1, 2003, the USPTO duly and legally issued U.S. Patent No. 6,587,261 (“the ’261 Patent”), entitled “Optical Transmission Systems Including Optical Amplifiers Apparatuses and Methods of Use Therein.” A copy of the ’261 Patent is attached hereto as Exhibit 5.

24. Optic153 owns all substantial right, title, and interest in the ’261 Patent, and holds the right to sue and recover damages for infringement thereof, including past infringement.

25. On Aug. 3, 2004, the USPTO duly and legally issued U.S. Patent No. 6,771,413 (“the ’413 Patent”), entitled “Optical Transmission Systems Including Optical Amplifiers, Apparatuses and Methods.” A copy of the ’413 Patent is attached hereto as Exhibit 6.

26. Optic153 owns all substantial right, title, and interest in the ’413 Patent, and holds the right to sue and recover damages for infringement thereof, including past infringement.

**COUNT I - INFRINGEMENT OF U.S. PATENT NO. 6,115,174**

27. Plaintiff incorporates and realleges the preceding paragraphs as if fully set forth herein.

28. The ’174 Patent is directed to systems and methods for controlling signal variation in an optical fiber, as described and claimed in the ’174 Patent.

29. AT&T directly infringed at least Claim 19 of the ’174 Patent, in this judicial District and elsewhere in the United States, pursuant to 35 U.S.C. § 271(a), literally or under the

doctrine of equivalents, by, among other things, by making, using, selling, offering to sell, and/or importing in or into the United States, without authority: products, devices, systems, and/or components of systems that provide pump energy in a plurality of pump wavelengths to controllably produce Raman transmission in an optical fiber (“’174 Accused Instrumentalities”). The ’174 Accused Instrumentalities include, for example and without limitation, AT&T’s optical communications networks and systems (e.g., AT&T fiber-optic network and fiber-to-the-premises network such as AT&T Fiber) that employ Raman amplification or Raman amplifiers and/or systems, including Raman optical amplifiers (e.g., Cisco Systems’s (“Cisco”) OPT-RAMP-C, OPT-RAMP-CE, and EDRA-x-xx and Fujitsu Ltd.’s (“Fujitsu”) L160 Backward Raman Amplifier), counter-propagating and co-propagating (e.g., Cisco’s 15454-M-RAMAN-CTP card and 15454-M-RAMAN-COP card) Raman units, Raman platforms and systems (e.g., Cisco Network Convergence System (“NCS”) 2000 Series network platform and associated hardware and software, Fujitsu’s IFinity platforms including Flashwave 7500 and L130 CDC ROADM Blade and associated hardware and software), and/or other telecommunications networks and systems that deploy or have deployed such platforms or components.

30. By way of example, the representative instrumentality, AT&T’s fiber-optic network, employs Cisco’s NCS 2000 Series network platform and infringes the ’174 Patent. *See, e.g.*, “Cisco Network Convergence System 2000 Series Data Sheet” (“**NCS 2000 Series Data Sheet**”) at 10, *available at* [https://www.cisco.com/c/en/us/products/collateral/optical-networking/network-convergence-system-2000-series/data\\_sheet\\_c78-729221.html](https://www.cisco.com/c/en/us/products/collateral/optical-networking/network-convergence-system-2000-series/data_sheet_c78-729221.html) (last visited Apr. 1, 2020) (showing that the NCS 2002 conforms with AT&T-specific requirements)(last visited Nov. 30, 2020). An image of the representative instrumentality, NCS 2000 Series network platform, is shown below:



See “Cisco Network Convergence System 2000 Series,” available at <https://www.cisco.com/c/en/us/products/optical-networking/network-convergence-system-2000-series/index.html> (last visited Apr. 1, 2020). The NCS 2000 Series network platform includes Raman amplifiers such as OPT-RAMP-C, OPT-RAMP-CE, and EDRA. An image of the OPT-RAMP-C is shown below:



See “Raman C-Band Optical Amplifier for the Cisco ONS 15454 Multiservice Transport Platform” (“**Raman C-Band Datasheet**”) at 1, available at [https://www.cisco.com/c/en/us/products/collateral/optical-networking/ons-15454-series-multiservice-provisioning-platforms/data\\_sheet\\_c78-500925.html](https://www.cisco.com/c/en/us/products/collateral/optical-networking/ons-15454-series-multiservice-provisioning-platforms/data_sheet_c78-500925.html) (last visited Apr. 1, 2020).

31. As another example, AT&T’s fiber-optic network, employs Fujitsu’s Flashwave 7500 since as early as 2011. See, e.g., “Fujitsu Wins Key Domain Supplier Status with AT&T,”



(“**Fujitsu Wins Supplier Status**”), available at

[https://www.convergedigest.com/2012/01/fujitsu-wins-key-domain-supplier-status\\_29.html?m=1](https://www.convergedigest.com/2012/01/fujitsu-wins-key-domain-supplier-status_29.html?m=1)

(last visited Nov. 30, 2020) (“Fujitsu Network Communications has been selected as one of

AT&T's Domain Suppliers for optical and transport equipment. The multi-year selection covers equipment used to expand and maintain AT&T's metropolitan and long-haul network

infrastructure.”); see also Sean Ryan, “AT&T shows what lies underneath streetcar route on

Broadway,” *Milwaukee Business Journal* (Sep. 1, 2011) (“**AT&T Milwaukee Business**

**Journal**”), available at [https://www.bizjournals.com/milwaukee/blog/2011/09/att-shows-with-](https://www.bizjournals.com/milwaukee/blog/2011/09/att-shows-with-lies-underneath-broadway.html)

[lies-underneath-broadway.html](https://www.bizjournals.com/milwaukee/blog/2011/09/att-shows-with-lies-underneath-broadway.html) (last visited Nov. 30, 2020) (“ The racks hold high-tech gizmos

like the Fujitsu Flashwave 7500 that handle fiber optics carrying 80 circuits pumping

information at 40 gigs a second, said telecommunications specialist Walter Spitzer, who runs the

third floor and nicknamed the place “Wally’s World.”) An image of the representative

instrumentality, Flashwave 7500, is shown below:

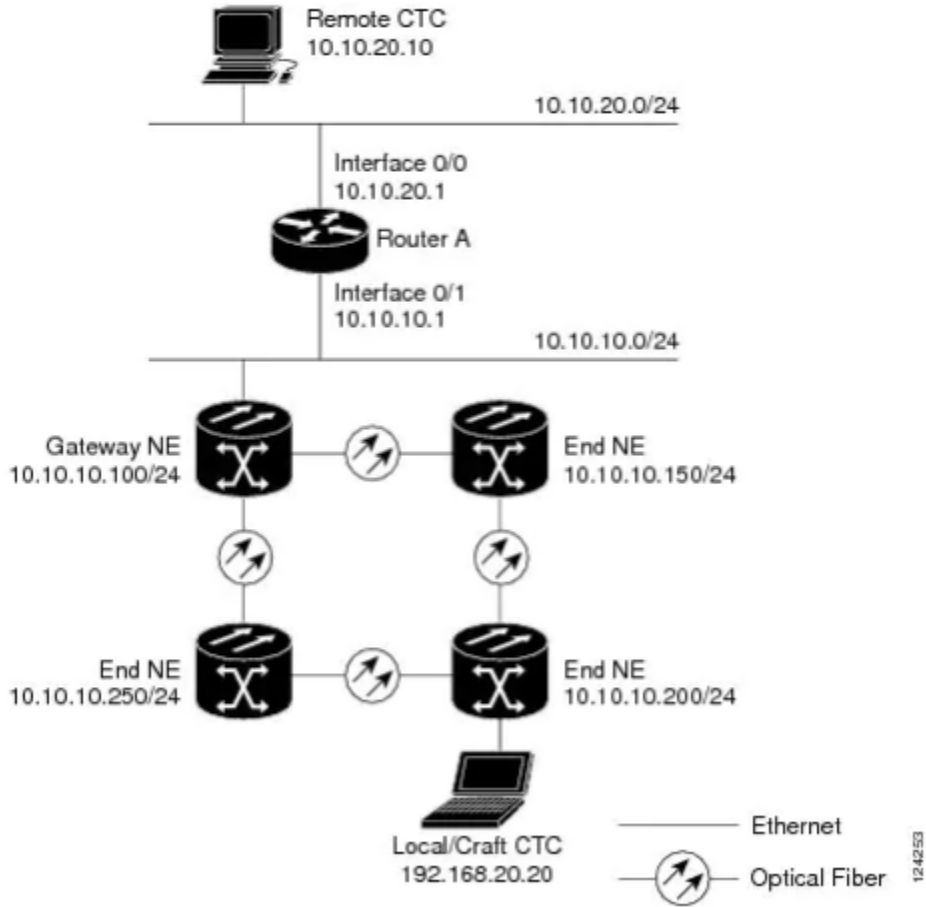


See “Flashwave 7500 Multifunction ROADM/DWDM Platform” (“**Flashwave 7500 Multifunction ROADM/DWDM Platform**”) at 1, *available at* <https://www.fujitsu.com/us/Images/flashwave7500.pdf> (last visited Apr. 1, 2020). The Flashwave 7500 employs EDFA and Raman amplifiers. See “Response to State of Utah Data Communications Products & Services Solicitation JP14001” (“**Fujitsu’s Response to State of Utah**”) at 659, *available at* [https://s3-us-west-2.amazonaws.com/wsca-uploads/1420829097\\_Fujitsu%20Network%20Communications%20Proposal.pdf](https://s3-us-west-2.amazonaws.com/wsca-uploads/1420829097_Fujitsu%20Network%20Communications%20Proposal.pdf) (last visited Apr. 1, 2020) (“Raman Amplifiers • Raman Amplifiers Unit Interconnections • Dispersion Compensations • Shelf Hierarchy - HUB Node - ETSI Add/Drop Node Equipment - ETSI HUB Node Equipment with Raman Amplifiers.”); *see also* “Flashwave 7500 Small Systems,” (“**Flashwave 7500 Small Systems Data Sheet**”) at 1 *available at* <https://www.fujitsu.com/downloads/TEL/fnc/datasheets/flashwave7500s.pdf> (last visited Apr. 1, 2020) (“Optical Span Lengths • Point-to-point Up to 20 km • Point-to-point with EDFA Up to 100 km”).

32. More specifically, the ’174 Accused Instrumentalities, including the representative instrumentality, AT&T’s fiber-optic network, perform a method of controlling signal variation in an optical fiber comprising providing an optical fiber (e.g., optical fiber(s) connected between optical nodes, optical terminal units, and optical network units) configured to produce concentrated Raman gain in a signal wavelength range. *See, e.g.*, Cisco NCS 2000 Series Network Configuration Guide, Release 10.x.x, Chapter: Managing Network Connectivity (“**Managing Network Connectivity**”) at Fig. 10, *available at* [https://www.cisco.com/c/en/us/td/docs/optical/15000r10\\_0/ncs/network\\_config/guide/b\\_ncs\\_network\\_configuration/b\\_ncs\\_network\\_configuration\\_chapter\\_01110.html](https://www.cisco.com/c/en/us/td/docs/optical/15000r10_0/ncs/network_config/guide/b_ncs_network_configuration/b_ncs_network_configuration_chapter_01110.html) (last visited January 27,

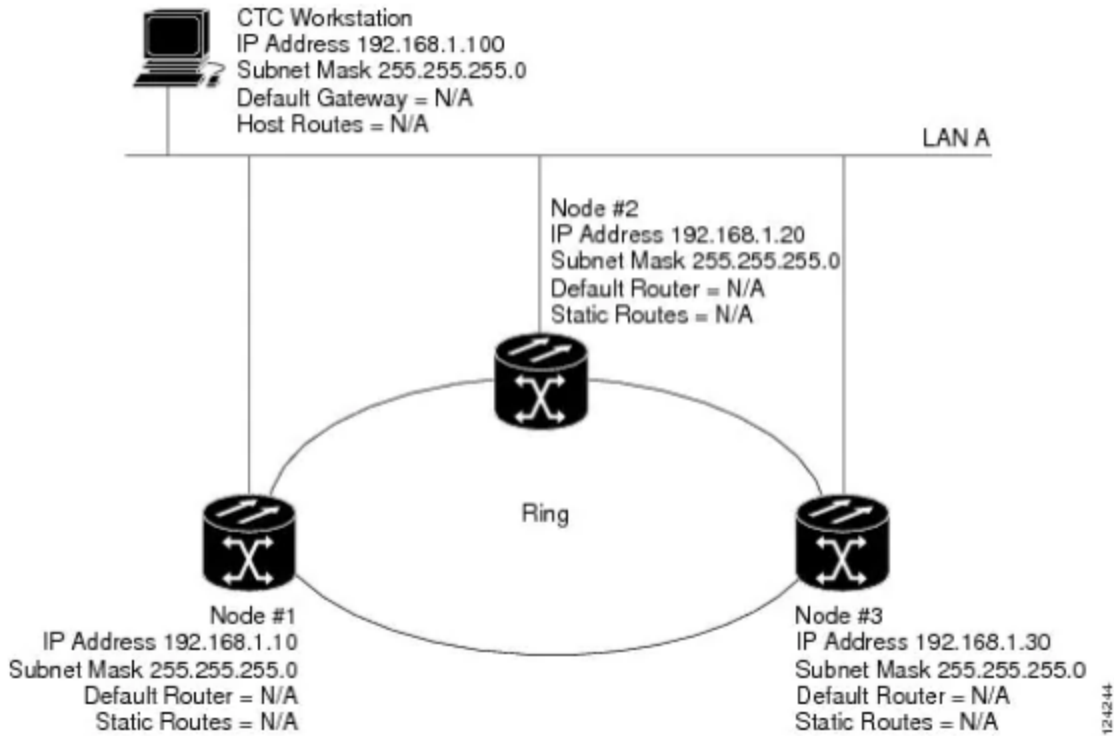
2021) (showing an NCS Gateway Network Element and NCS End Network Elements in an optical fiber network with a remote Cisco Transport Controller):

**Figure 10. Scenario 7: Proxy Server with GNE and ENEs on the Same Subnet (ANSI and ETSI)**

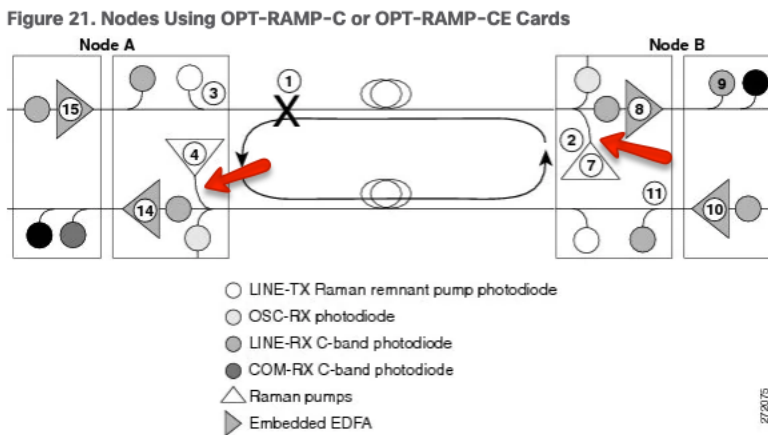


See also *id.* at Fig. 1 (showing NCS nodes connected in a LAN):

Figure 1. Scenario 1: CTC and NCS on Same Subnet (ANSI and ETSI)



See also “Cisco NCS 2000 Series Network Configuration Guide, Release 10.x.x, Chapter: Network Reference” (“**Network Reference**”) at 1, at Fig. 21 available at [https://www.cisco.com/c/en/us/td/docs/optical/15000r10\\_0/ncs/network\\_config/guide/b\\_ncs\\_network\\_configuration/b\\_ncs\\_network\\_configuration\\_chapter\\_0111.html#ID209](https://www.cisco.com/c/en/us/td/docs/optical/15000r10_0/ncs/network_config/guide/b_ncs_network_configuration/b_ncs_network_configuration_chapter_0111.html#ID209) (last visited Apr. 1, 2020) (annotated):



*See also* “Cisco Network Convergence System 2000 Series Erbium-Doped Raman Amplifiers Data Sheet” (“**NCS 2000 Datasheet**”) at 1, *available at*

<https://www.cisco.com/c/en/us/products/collateral/optical-networking/network-convergence-system-2000-series/datasheet-c78-735035.html> (last visited Apr. 1, 2020) (“The Raman pump

provides the following features (Figure 4): ● Total pump power of 1000 mW, consisting of four pumps over four wavelengths ● Raman pump back-reflection detector to detect the amount of

Raman pump power back-scattered by the LINE-RX connector and by the transmission fiber.

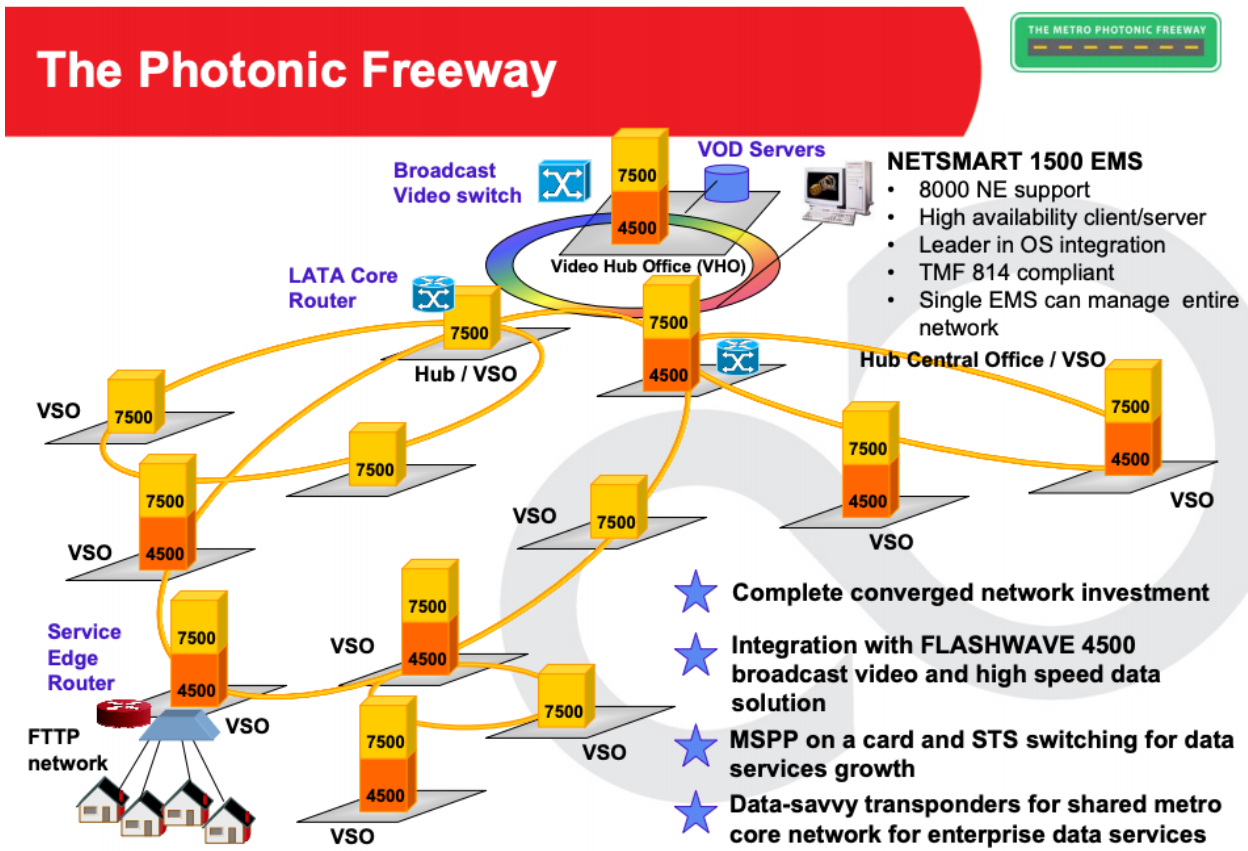
...”); *see also* “Flashwave 7500 ROADM” (“**Flashwave 7500 ROADM**”) at 11, *available at*

[https://www.fujitsu.com/downloads/TEL/fnc/downloads/fw7500\\_roadm\\_030305.pdf](https://www.fujitsu.com/downloads/TEL/fnc/downloads/fw7500_roadm_030305.pdf) (last visited

Apr. 1, 2020) (showing each VSO (video serving office) and VHO (video hub office) connected

via optical transmission fibers, which are connected to the fibers that produce Raman

amplification):

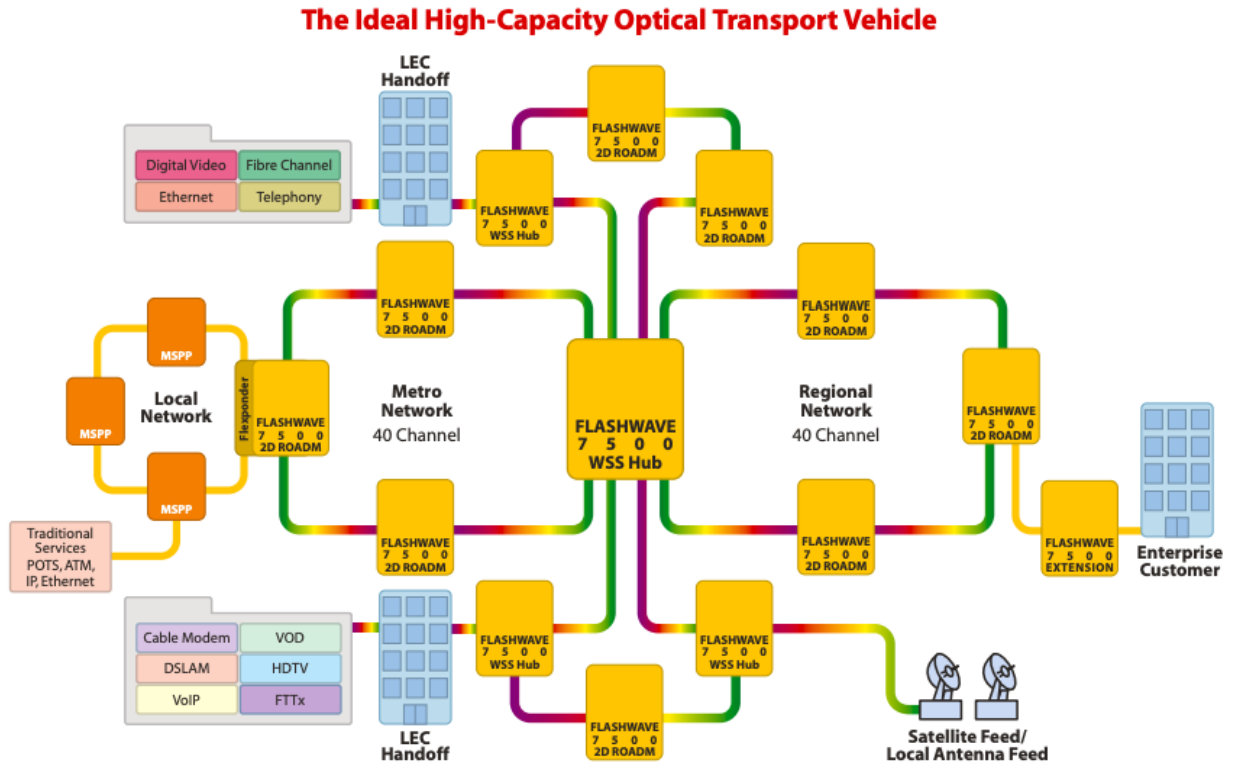


11

For Fujitsu and Verizon Use Only



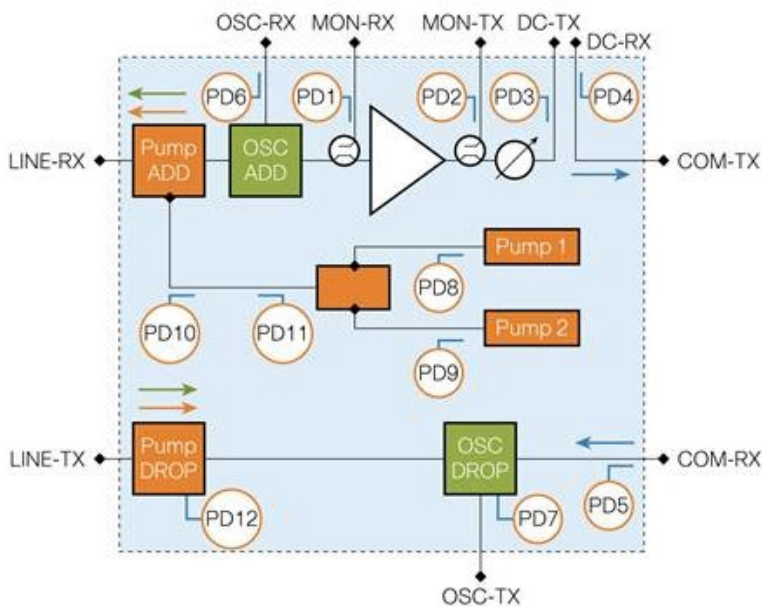
See also **Flashwave 7500 Multifunction ROADM/DWDM Platform** at 5 (showing each hub/ROADM being connected via optical fibers):



33. Also, the '174 Accused Instrumentalities, including the representative instrumentality, AT&T's fiber-optic network, couple a pump source (e.g., two pump lasers) to the fiber to provide pump energy in a plurality of pump wavelengths (e.g., 1425 nm and 1452 nm) having sufficient pump energy to produce Raman gain and a signal variation profile in the signal wavelength range (e.g., 1529.0 nm to 1562.5 nm) and to controllably produce amplification, attenuation and lossless transmission in the optical fiber. *See, e.g.*, "Cisco NCS 2000 Series Network Configuration Guide, Release 10.x.x, Chapter: Node Reference" ("**Node Reference**") at 1, *available at* [https://www.cisco.com/c/en/us/td/docs/optical/15000r10\\_0/ncs/network\\_config/guide/b\\_ ncs\\_network\\_configuration/b\\_ ncs\\_network\\_configuration\\_chapter\\_0100.html](https://www.cisco.com/c/en/us/td/docs/optical/15000r10_0/ncs/network_config/guide/b_ ncs_network_configuration/b_ ncs_network_configuration_chapter_0100.html) (last visited Apr. 1, 2020) ("The Raman pump is equipped with two different Raman pumps transmitting powers (P1 and P2) at two different wavelengths  $\lambda_1$  and  $\lambda_2$ . During installation, the two pumps

alternatively turn ON and OFF at two different power values. Lambda1 and Lambda2 signals are used as probes at the end of spans to measure Raman gain efficiency of the two Raman pumps separately.”); *see also* **Raman C-Band Datasheet** at 1 (“The OPT-RAMP-C features an embedded low-noise EDFA gain block for C-band optical amplification and optimized system performances with Raman amplification. The Raman pumps embedded in the unit use on the latest laser technology, enabling up to 500 milliwatts (mW) of power combining just two pump lasers, thus obtaining very high efficiency and low power consumption (Figure 2). ... A dedicated software application has been incorporated in Cisco Transport Controller to allow a fully automatic and simple configuration and tuning of the optical Raman amplifiers along a DWDM link. This software application, called Raman Tuning Wizard, can take advantage of tunable Transponder or Muxponder units to evaluate the physical characteristics of the span’s fiber, determine the optimal mix of Raman pump wavelengths, and define the contribution of Raman versus EDFA for the overall optical amplification of the unit.”); *see also id.* at Fig. 2:

**Figure 2. OPT-RAMP-C Block Diagram**





34. Also, on information and belief, AT&T's deployment of Fujitsu's 1Finity platforms in its fiber-optic network, such as the Flashwave 7500, include the deployment and use of Fujitsu's Raman amplifiers (e.g., Fujitsu's L160 Backward Raman Amplifier), which include coupling a pump source to the fiber to provide pump energy in a plurality of pump wavelengths to produce Raman gain and a signal variation profile in the signal wavelength range (e.g., 1528.58 nm – 1566.93 nm) and to controllably produce amplification, attenuation and lossless transmission in the optical fiber (e.g., controlled by the L130 CDC ROADM Blade). *See, e.g.*, "1Finity L130 32-Port CDC ROADM Blade Data Sheet" ("**1Finity L130 Data Sheet**") at 1, *available at* [http://images.demand.definingnetworks.com/Web/FujitsuNetworkCommunications/%7Bcd4e710f-adcb-4cb4-bcee-7bf3eabf2481%7D\\_1FINITY\\_L130\\_32-Port\\_CDC\\_ROADM\\_Blade.pdf](http://images.demand.definingnetworks.com/Web/FujitsuNetworkCommunications/%7Bcd4e710f-adcb-4cb4-bcee-7bf3eabf2481%7D_1FINITY_L130_32-Port_CDC_ROADM_Blade.pdf) (last visited Apr. 1, 2020); *see also* "1Finity L160 Backward Raman Amplifier Data Sheet" ("**1Finity L160 Data Sheet**") at 1, *available at* [http://images.demand.definingnetworks.com/Web/FujitsuNetworkCommunications/%7B8d3d82fe-ea62-4c7f-93e2-a1586a8f61d1%7D\\_1FINITY\\_L160\\_Backward\\_Raman\\_Amplifier.pdf](http://images.demand.definingnetworks.com/Web/FujitsuNetworkCommunications/%7B8d3d82fe-ea62-4c7f-93e2-a1586a8f61d1%7D_1FINITY_L160_Backward_Raman_Amplifier.pdf) (last visited Apr. 1, 2020).

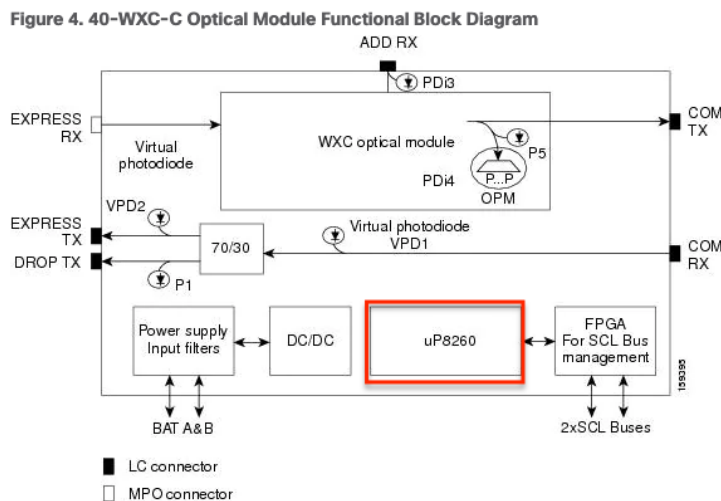
35. Further, the '174 Accused Instrumentalities, including the representative instrumentality, AT&T's fiber-optic network, control the pump energy provided in at least one of said pump wavelengths to vary the signal variation profile (e.g., from 8.5dB to 13.5dB) over the signal wavelength range (e.g., 1529.0 nm to 1562.5 nm) in the optical fiber and produce amplification, attenuation and lossless transmission in the optical fiber. *See, e.g.*, **Network Reference** at 1 ("After the GEDFA is set, APC regulates the power on the VOA (DC-TX port) of the OPT-RAMP-C or OPT-RAMP-CE card to match the target Power (COM-TX port) value,

and accounts for the actual DCU loss. ... The APC adjusts the VOA attenuation of the OPT-RAMP-C or OPT-RAMP-CE card if the Total Power (LINE-TX port) does not match the expected value that is equal to the maximum power multiplied by the number of active channels. The VOA attenuation value on the OPT-RAMP-C or OPT-RAMP-CE cards is set to 15 dB. This value ensures that the system turns up in any circumstance.”); *see also* **Raman C-Band Datasheet** at 1 (“The OPT-RAMP-C also provides an embedded fast Gain Control for transient suppression to respond quickly to network changes without impairments and degradation of existing wavelengths. In addition to this, the unit features an embedded Gain Flattening Filter (GFF) for the compensation of the ripple generated by the cascaded Raman and EDFA stages. The amplifier integrates a software-controllable variable optical attenuator (VOA) to provide gain tilt control capabilities and to optimize and control the per-channel power at the input of the mid-access loss for dispersion compensation units (DCUs). ... A dedicated software application has been incorporated in Cisco Transport Controller to allow a fully automatic and simple configuration and tuning of the optical Raman amplifiers along a DWDM link. This software application, called Raman Tuning Wizard, can take advantage of tunable Transponder or Muxponder units to evaluate the physical characteristics of the span’s fiber, determine the optimal mix of Raman pump wavelengths, and define the contribution of Raman versus EDFA for the overall optical amplification of the unit.”); *see also* **Node Reference** at 1 (“Automatic Raman Pump Calculation The Raman gain depends on the characteristics of the span (fiber type and span loss). To obtain optimum Raman gain, a correct mix of pump powers must be provisioned. Tuning of the four Raman pumps is crucial before traffic is provisioned. The tuning procedure is called Automatic Raman Power Calculation (ARPC). This procedure assesses the Raman gain on a C-band signal using pre-defined Raman pump values. ARPC applies to the

RAMAN-CTP and EDRA cards.”); *see also* “Cisco NCS 2000 Series Line Card Configuration Guide, Release 10.x.x, Chapter: Provisioning Reconfigurable Optical Add/Drop Cards”

(“**Release 10.x Optical Amplifier Cards**”) at 1, *available at*

[https://www.cisco.com/c/en/us/td/docs/optical/15000r10\\_0/ncs/linecard\\_config/guide/b\\_ncs\\_line\\_card\\_configuration/b\\_ncs\\_line\\_card\\_configuration\\_chapter\\_01010.html](https://www.cisco.com/c/en/us/td/docs/optical/15000r10_0/ncs/linecard_config/guide/b_ncs_line_card_configuration/b_ncs_line_card_configuration_chapter_01010.html) (last visited Apr. 1, 2020) (showing a processor “uP2860” to control the pump energy to vary the signal variation profile) (annotated):



36. Also, on information and belief, AT&T’s deployment of Fujitsu’s 1Finity platforms in its fiber-optic network also requires controlling the pump energy provided in the at least one of the pump wavelengths (e.g., via the L130 CDC ROADM Blade) to vary the signal variation profile over the signal wavelength range in the optical fiber and produce amplification, attenuation and lossless transmission in the optical fiber. *See, e.g., 1Finity L130 Data Sheet at 1; see also 1Finity L160 Data Sheet at 1.*

37. Discovery is expected to uncover the full extent of AT&T’s unlawful use of Optic153’s patented technology in the ’174 Patent beyond the ’174 Accused Instrumentalities already identified through public information.

38. On information and belief, AT&T also directly infringed at least Claim 19 of the '174 Patent by testing the '174 Accused Instrumentalities, including in relation to network testing and improvement responsive to user/customer feedback, and demonstration at trade shows, sales facilities, customer sites, and training/tutorial videos.

39. Plaintiff has suffered damages as a result of AT&T's infringement of the '174 Patent.

40. Plaintiff reserves the right to modify its infringement theories as discovery progresses in this case. Plaintiff shall not be estopped for purposes of its infringement contentions or its claim constructions by the foregoing discussions on how the '174 Accused Instrumentalities infringe the '174 Patent. Plaintiff intends only that the foregoing discussions satisfy the notice requirements of Rule 8(a)(2) of the Federal Rule of Civil Procedure, and that they should not be construed as Plaintiff's preliminary or final infringement contentions or preliminary or final claim construction positions.

**COUNT II - INFRINGEMENT OF U.S. PATENT NO. 6,236,487**

41. Plaintiff incorporates and realleges the preceding paragraphs as if fully set forth herein.

42. The '487 Patent is directed to systems and methods for controlling an optical transmission system, as described and claimed in the '487 Patent.

43. AT&T directly infringed at least Claims 26-28 of the '487 Patent, in this judicial District and elsewhere in the United States, pursuant to 35 U.S.C. § 271(a), literally or under the doctrine of equivalents, by, among other things, by making, using, selling, offering to sell, and/or importing in or into the United States, without authority: products, devices, systems, and/or components of systems that control a concentrated optical amplifier to vary an optical signal to

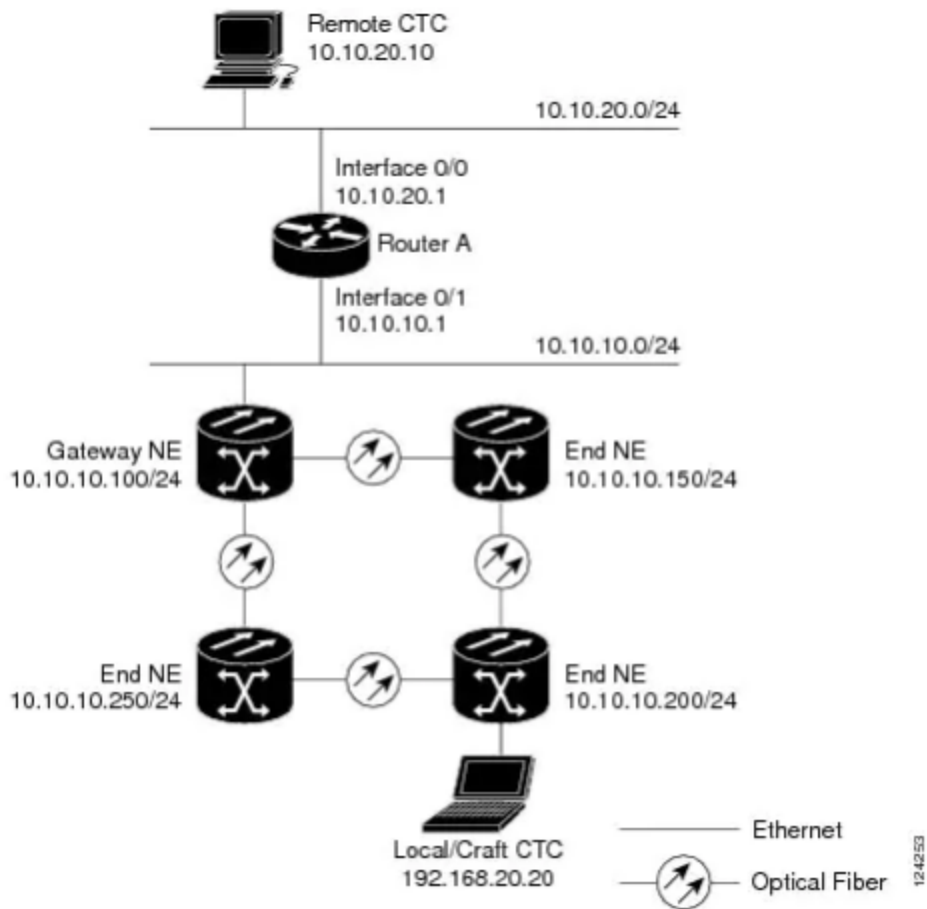
have at least one desired signal characteristics when the optical signal reaches an optical processing node (“’487 Accused Instrumentalities”). The ’487 Accused Instrumentalities include, for example and without limitation, AT&T’s optical communications networks and systems (e.g., AT&T fiber-optic network and fiber-to-the-premises network such as AT&T Fiber) that employ Cisco’s NCS 2000 Series network platform including associated hardware and software, ONS 15454 Series platform including associated hardware and software, Fujitsu’s 1Finity platforms including Flashwave 7500 and L130 CDC ROADM Blade including associated hardware and software, and/or other telecommunications networks and systems that deploy or have deployed such platforms or components.

44. By way of example, the representative instrumentality, AT&T’s fiber-optic network, employs Cisco’s NCS 2000 Series network platform and infringes the ’487 Patent. *See, e.g., NCS 2000 Series Data Sheet* at 10 (indicating that NCS 2002 conforms to AT&T-specific requirements). The NCS 2000 Series network platform includes erbium doped fiber amplifiers (e.g., OPT-AMP-xx-x, OPT-EDFA-xx and Enhanced C-Band 96-Channel EDFA Amplifiers) and Raman amplifiers (e.g., OPT-RAMP-C, OPT-RAMP-CE, and EDRA-x-xx). *See, e.g., “A Switchable-Gain Optical Amplifier functioning in the flexible spectrum of C-Band for the Cisco NCS 2000 Platform Data Sheet” (“NCS 2000 Platform Data Sheet”)* at 1, *available at* <https://www.cisco.com/c/en/us/products/collateral/optical-networking/ons-15454-series-multiservice-transport-platforms/datasheet-c78-740502.html> (last visited Apr. 1, 2020); *see also* “Cisco NCS 2000 Series Line Card Configuration Guide, Release 10.x.x Chapter: Provisioning Optical Amplifier Cards” (“**Provisioning Optical Amplifier Cards**”) at 1, *available at* [https://www.cisco.com/c/en/us/td/docs/optical/15000r10\\_0/ncs/linecard\\_config/guide/b\\_ncs\\_line\\_card\\_configuration/ncs-test\\_chapter\\_0101.html](https://www.cisco.com/c/en/us/td/docs/optical/15000r10_0/ncs/linecard_config/guide/b_ncs_line_card_configuration/ncs-test_chapter_0101.html) (last visited Apr. 1, 2020).

45. As another example, AT&T's fiber-optic network, employs Fujitsu's Flashwave 7500 since as early as 2011. *See, e.g., Fujitsu Wins Supplier Status* ("Fujitsu Network Communications has been selected as one of AT&T's Domain Suppliers for optical and transport equipment. The multi-year selection covers equipment used to expand and maintain AT&T's metropolitan and long-haul network infrastructure."); *see also AT&T Milwaukee Business Journal* ("The racks hold high-tech gizmos like the Fujitsu Flashwave 7500 that handle fiber optics carrying 80 circuits pumping information at 40 gigs a second, said telecommunications specialist Walter Spitzer, who runs the third floor and nicknamed the place "Wally's World."). The Flashwave 7500 employs EDFA and Raman amplifiers. *See Fujitsu's Response to State of Utah* at 659 ("Raman Amplifiers • Raman Amplifiers Unit Interconnections • Dispersion Compensations • Shelf Hierarchy - HUB Node - ETSI Add/Drop Node Equipment - ETSI HUB Node Equipment with Raman Amplifiers."); *see also* "Flashwave 7500 Small Systems," ("Flashwave 7500 Small Systems Data Sheet") at 1 *available at* <https://www.fujitsu.com/downloads/TEL/fnc/datasheets/flashwave7500s.pdf> (last visited Apr. 1, 2020) ("Optical Span Lengths • Point-to-point Up to 20 km • Point-to-point with EDFA Up to 100 km").

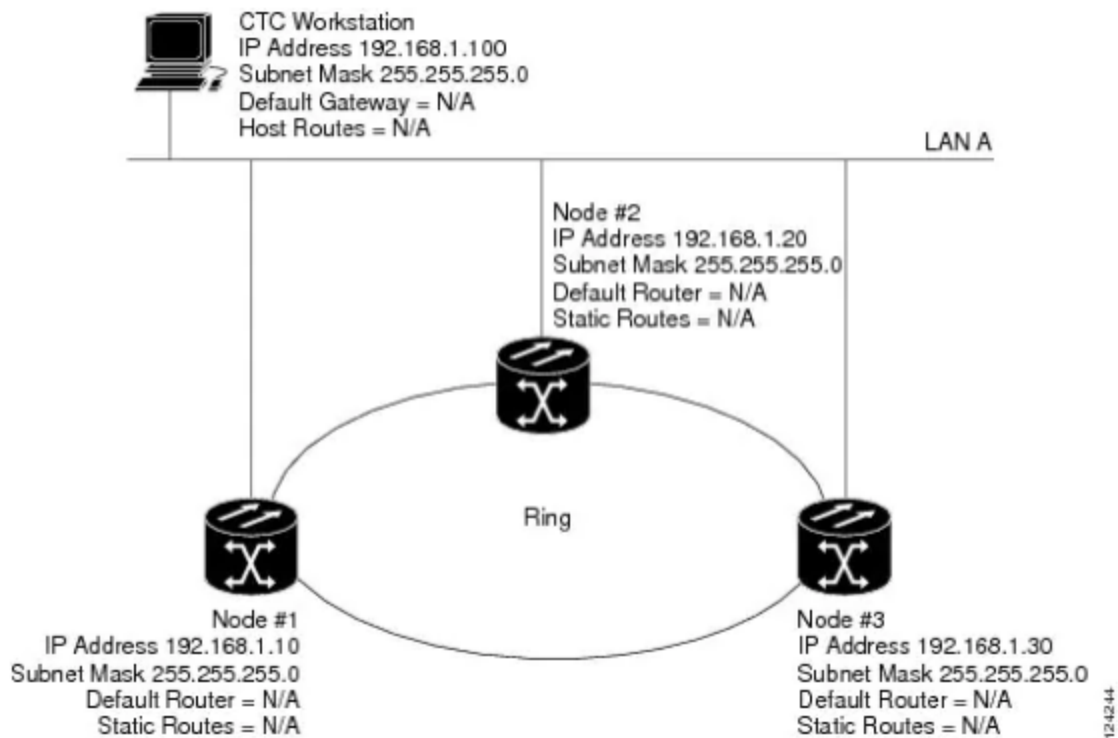
46. More specifically, the '487 Accused Instrumentalities, including the representative instrumentality, AT&T's fiber-optic network, perform a method of controlling an optical transmission system comprising positioning at least one signal varying device including a concentrated optical amplifier (e.g., EDFA or Raman amplifiers) remote from an optical processing node to vary an optical signal passing to the optical processing node. *See Managing Network Connectivity* at Fig. 10 (showing an NCS Gateway Network Element and NCS End Network Elements in an optical fiber network with a remote Cisco Transport Controller):

Figure 10. Scenario 7: Proxy Server with GNE and ENEs on the Same Subnet (ANSI and ETSI)

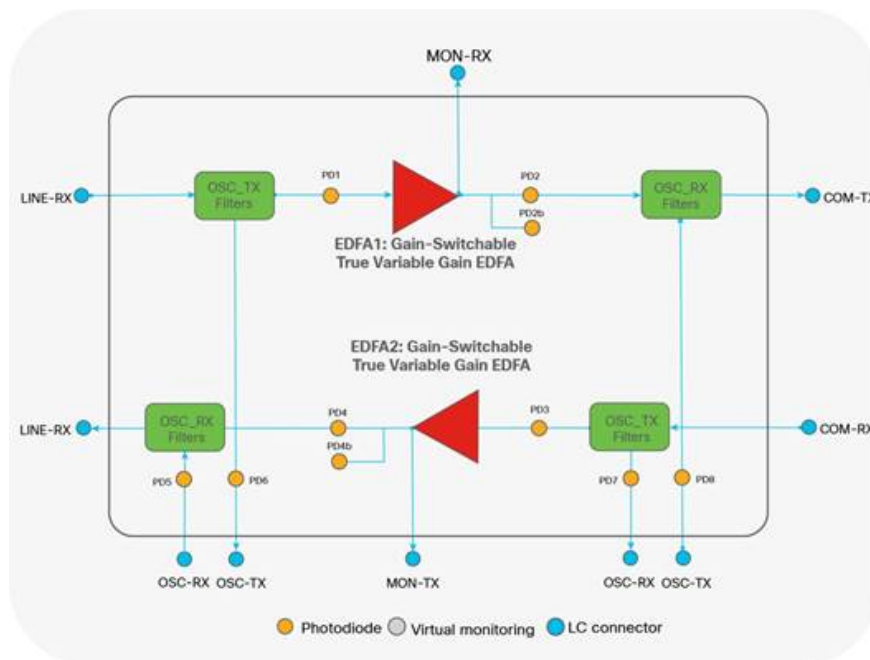


See also *id.* at Fig. 1 (showing NCS nodes connected to a LAN):

Figure 1. Scenario 1: CTC and NCS on Same Subnet (ANSI and ETSI)



See also Fig. 2 of NCS 2000 Platform Datasheet at 1 (showing the use of variable gain EDFAs):



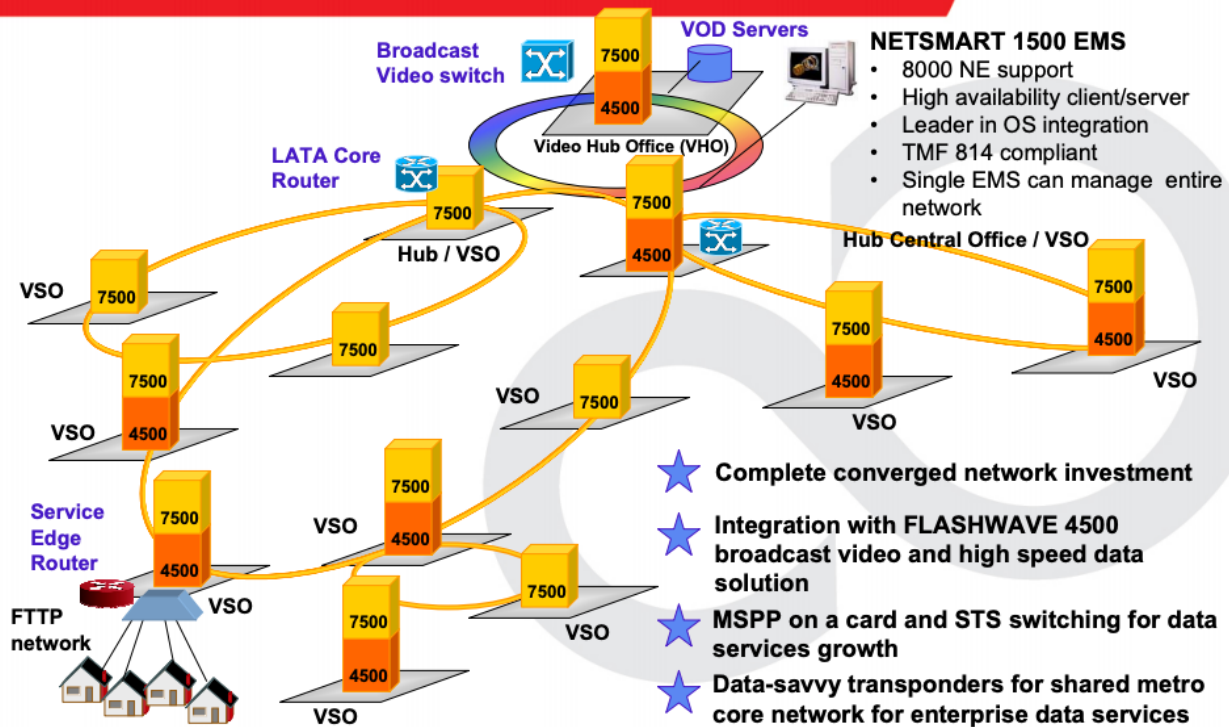


See also **NCS 2000 Series Data Sheet** at 1 (listing all suitable concentrated optical amplifiers including OPT-EDFA-xx, EDRAx-xx, OPT-AMP-C, OPT-AMP-17C, M-RAMAN-CTP, and M-RAMAN-COP):

Optical Amplifiers	
15454-OPT-EDFA-17=	Enhanced C-band 96 channel low cost amplifier 17 dB max gain, 50 GHz compatible, LC connector, includes two 2m LC/LC fiber-optic cables
15454-OPT-EDFA-24=	Enhanced C-band 96 channel low cost amplifier 24 dB max gain, 50 GHz compatible, LC connector, includes two 2m LC/LC fiber-optic cables
NCS2K-EDRA1-26C=	21dBm Erbium Doped Raman Amplifier 26dB Span - C-Band, includes one 2m LC/LC fiber-optic cables and one 2m E2000/PC High power fiber optical cable
NCS2K-EDRA1-35C=	21dBm Erbium Doped Raman Amplifier 35dB Span - C-Band, includes one 2m LC/LC fiber-optic cable and one 2m E2000/PC High power fiber optical cable
NCS2K-EDRA2-26C=	21dBm Erbium Doped Raman Amplifier + Bst 26dB Span - C-Band, includes two 2m LC/LC fiber-optic cables and one 2m E2000/PC High power fiber optical cable
NCS2K-EDRA2-35C=	21dBm Erbium Doped Raman Amplifier + Bst 35dB Span - C-Band, includes two 2m LC/LC fiber-optic cables and one 2m E2000/PC High power fiber optical cable
15454-OPT-AMP-C=	ONS 15454 Enhanced Optical Amplifier, includes two 2m LC/LC fiber-optic cable and one LC/LC LOOPBACK
15454-OPT-AMP-17C=	17dB Gain, Amp, includes two 2m LC/LC fiber-optic cable and one LC/LC LOOPBACK
15454-M-RAMAN-CTP=	15454 MSTP - Raman Amplifier - C-band - Counter-Propagating, includes two 2m E2000/PC High power fiber optical cable
15454-M-RAMAN-COP=	15454 MSTP - Raman Amplifier - C-band - Co-Propagating, includes one 2m E2000/PC High power fiber optical cable

47. As another example, on information and belief, the 1Finity platforms, such as the Flashwave 7500 deployed in AT&T's fiber-optic network, include Raman amplifiers (e.g., Fujitsu's L160 Backward Raman Amplifier) and EDFAs. The '487 Accused Instrumentalities, including the representative instrumentality, AT&T's fiber-optic network, perform a method of controlling an optical transmission system comprising positioning at least one signal varying device including a concentrated optical amplifier (e.g., EDFA or Raman amplifiers) remote from an optical processing node to vary an optical signal passing to the optical processing node. For example, the optical amplifier can be positioned between VSOs and VHSs:

## The Photonic Freeway



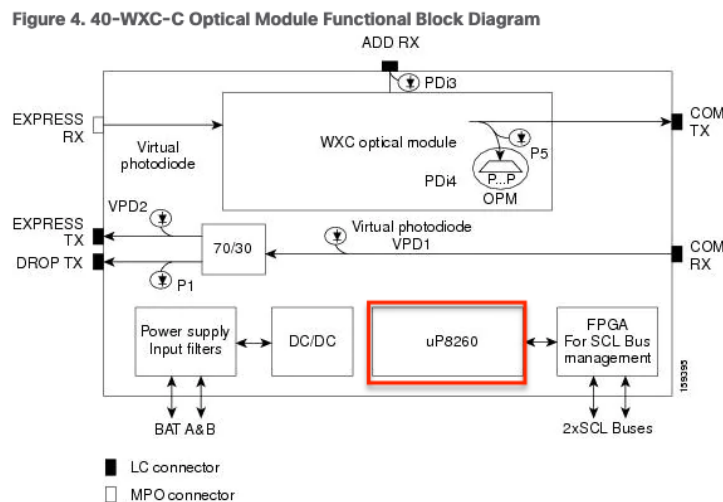
11

For Fujitsu and Verizon Use Only

See **Flashwave 7500 ROADM** at 1.

48. Also, the '487 Accused Instrumentalities, including the representative instrumentality, AT&T's fiber-optic network, control the at least one concentrated optical amplifier to vary the optical signal to have at least one desired signal characteristic when the optical signal reaches the optical processing node. See, e.g., **NCS 2000 Platform Data Sheet**, at 1 ("It supports 2 gain ranges: 12-24dB and 20-35dB (with tilt control) and noise figure optimized to each of the specified gain ranges. ... [T]he EDFA-35 switchable gain amplifier ... supports 2 different gain ranges and thus can handle a wide range of fiber parameter changes that could be incurred. ... [T]he amplifier is able to support up to 35dB of maximum gain (with tilt control) in the second gain range. Forsaking the control over tilt on a rare occasion, one can function beyond

this barrier as well. This is therefore a significant addition to the Cisco NCS 2000 portfolio that had Raman amplification solutions beyond 24dB in the Flex spectrum world.”); *see also* **Network Reference** at 1 (The Automatic Power Control “APC algorithms manage the optical parameters of the OPT-BST, OPT-PRE, OPT-AMP-17-C, 32DMX, 40-DMX-C, 40-DMX-CE, 40-SMR1-C, 40-SMR2-C, OPT-AMP-C, OPT-PRE, OPT-BST-E, OPT-AMP-17C, OPT-EDFA-17, OPT-EDFA-24, 80-WXC-C, 40-WXC-C, 40-WSS, 32-WSS, 40-MUX, 40-DMX, RAMAN-CTP, RAMAN-COP, OPT-RAMP-C, OPT-RAMP-CE, EDRA-1, EDRA-2, SMR-20, SMR-9, 16-WXC, and PSM cards. ... The APC changes the Gain setpoint of the embedded EDFA to reach the value that is equal to Power (DC-TX port) value multiplied by the number of active channels. The APC can set the Gain setpoint of the embedded EDFA (GEDFA) in the following ranges: OPT-RAMP-C 10 dB < GEDFA < 18 dB OPT-RAMP-CE 7 dB < GEDFA < 13 dB.”); *see also* **Release 10.x Optical Amplifier Cards** at 1 (showing a processor “uP8260” to control the pump energy to vary the signal variation profile) (annotated):



49. As another example, on information and belief, the IFinity platforms, such as the Flashwave 7500 deployed in AT&T’s fiber-optic network, control the at least one concentrated optical amplifier (e.g., EDFA or Raman amplifiers) to vary the optical signal to have at least one

desired signal characteristic (e.g., controlled by the L130 CDC ROADM Blade) when the optical signal reaches the optical processing node (e.g., at either VSO or VHO). *See also* **Fujitsu’s Response to State of Utah** at 659 (“Raman Amplifiers • Raman Amplifiers Unit Interconnections • Dispersion Compensations • Shelf Hierarchy - HUB Node - ETSI Add/Drop Node Equipment - ETSI HUB Node Equipment with Raman Amplifiers.”); *see also* **Flashwave 7500 Small Systems Data Sheet** at 1 (“Optical Span Lengths • Point-to-point Up to 20 km • Point-to-point with EDFA Up to 100 km”).

50. Further, the ’487 Accused Instrumentalities, including the representative instrumentality, AT&T’s fiber-optic network, also detect characteristics of the optical signal and compare detected characteristics of the optical signal to the at least one desired characteristic, wherein controlling includes controlling the at least one signal varying device to vary the optical signal until the detected characteristics correspond to the desired characteristics (e.g., target power) when the optical signal arrives at the processing nodes. *See, e.g.,* **Network Reference** at 1 (“After the GEDFA is set, APC regulates the power on the VOA (DC-TX port) of the OPT-RAMP-C or OPT-RAMP-CE card to match the target Power (COM-TX port) value, and accounts for the actual DCU loss.”); *see also* **Provisioning Optical Amplifier Cards** (“OPT-AMP-C Card ... Fixed output power mode (mode used during provisioning) ... ASE compensation in Constant Gain and Constant Output Power modes ... OPT-EDFA-17 and OPT-EDFA-24 Cards ... Constant gain mode ... ASE compensation in Constant Gain and Constant Output Power modes”); **Node Reference** at 1 (“The APC dynamically adjusts the tilt reference (TILT REFERENCE) value to meet the target taking into consideration the Raman tilt (TILT RAMAN) that the Raman installation wizard calculates and the EDFA tilt (TILT EDFA) that is

calculated by the OPT-RAMP-C or OPT-RAMP-CE card based on its GEDFA value: TILT CTP setpoint = TILT RAMAN + TILT EDFA + TILT REFERENCE”).

51. As another example, on information and belief, the IFinity platforms, such as the Flashwave 7500 deployed in AT&T’s fiber-optic network, detect characteristics of the optical signal and compare detected characteristics of the optical signal to the at least one desired characteristic, wherein controlling includes controlling the at least one signal varying device (e.g., controlled by the L130 CDC ROADM Blade) to vary the optical signal until the detected characteristics correspond to the desired characteristics when the optical signal arrives at the processing nodes.

52. On information and belief, the ’487 Accused Instrumentalities, including the representative instrumentality, AT&T’s fiber-optic network, also select the at least one desired signal characteristic from the group consisting of signal-to-noise ratio, signal intensity, noise intensity, and combinations thereof. *See, e.g., NCS 2000 Platform Data Sheet*, at 1 (“It supports 2 gain ranges: 12-24dB and 20-35dB (with tilt control) and noise figure optimized to each of the specified gain ranges. ... This unit supports 2 different gain ranges and thus can handle a wide range of fiber parameter changes that could be incurred. It is significant to note that there are amplifiers in the market that support ranges from say 5 to 35dB; but their noise figure is often traded off to support this wide gain range. But with the EDFA-35, the ability to switch to different gain ranges is the critical difference and that allows the optimization of the noise figure on either range: a unique capability.”).

53. As another example, on information and belief, the IFinity platforms, such as the Flashwave 7500 deployed in AT&T’s fiber-optic network, select the at least one desired signal characteristic from the group consisting of signal-to-noise ratio, signal intensity, noise intensity,

and combinations thereof (e.g., as selected by the L130 CDC ROADM Blade) to vary the optical signal until the detected characteristics.

54. Discovery is expected to uncover the full extent of AT&T's unlawful use of Optic153's patented technology in the '487 Patent beyond the '487 Accused Instrumentalities already identified through public information.

55. On information and belief, AT&T also directly infringed at least Claims 26-28 of the '487 Patent by testing the '487 Accused Instrumentalities, including in relation to network testing and improvement responsive to user/customer feedback, and demonstration at trade shows, sales facilities, customer sites, and training/tutorial videos.

56. Plaintiff has suffered damages as a result of AT&T's infringement of the '487 Patent.

57. Plaintiff reserves the right to modify its infringement theories as discovery progresses in this case. Plaintiff shall not be estopped for purposes of its infringement contentions or its claim constructions by the foregoing discussions on how the '487 Accused Instrumentalities infringe the '487 Patent. Plaintiff intends only that the foregoing discussions satisfy the notice requirements of Rule 8(a)(2) of the Federal Rule of Civil Procedure, and that they should not be construed as Plaintiff's preliminary or final infringement contentions or preliminary or final claim construction positions.

**COUNT III - INFRINGEMENT OF U.S. PATENT NO. 6,344,922**

58. Plaintiff incorporates and realleges the preceding paragraphs as if fully set forth herein.

59. The '922 Patent is directed to systems and methods for controlling signal variation in an optical fiber, as described and claimed in the '922 Patent.

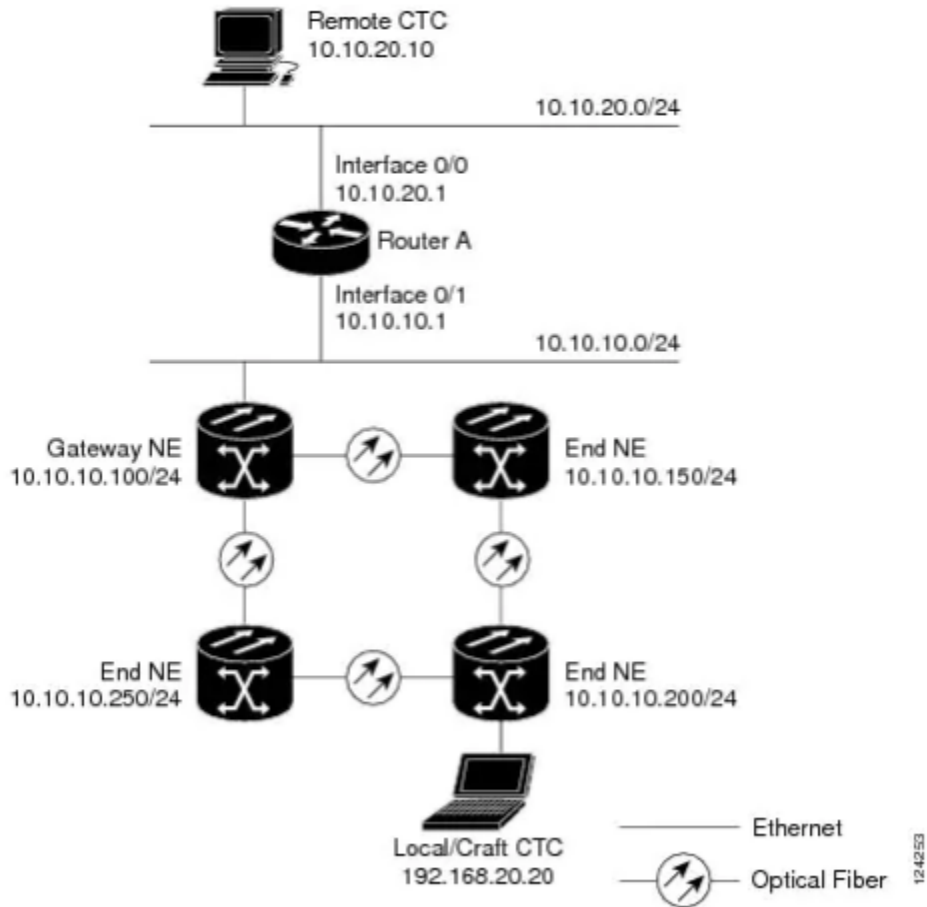
60. AT&T directly infringed at least Claim 32 of the '922 Patent, in this judicial District and elsewhere in the United States, pursuant to 35 U.S.C. § 271(a), literally or under the doctrine of equivalents, by, among other things, by making, using, selling, offering to sell, and/or importing in or into the United States, without authority: products, devices, systems, and/or components of systems that provide two pump sources with at least one being controlled to vary a signal variation profile and Raman gain ("'922 Accused Instrumentalities"). The '922 Accused Instrumentalities include, for example and without limitation, Raman C-Band optical amplifiers (e.g., OPT-RAMP-C, OPT-RAMP-CE, and EDRA-x-xx), counter-propagating (e.g., 15454-M-RAMAN-CTP card) and co-propagating (e.g., 15454-M-RAMAN-COP card) Raman units including associated hardware and software, Raman platforms and systems (e.g., Cisco Network Convergence System ("NCS") 2000 Series network platform) including associated hardware and software, and/or telecommunications networks and systems (e.g., AT&T fiber-optic network and fiber-to-the-premises network such as AT&T Fiber) that employ such platforms or components.

61. By way of example, the representative instrumentality, AT&T's fiber-optic network, employs Cisco's NCS 2000 Series network platform and infringes the '922 Patent. *See, e.g., NCS 2000 Series Data Sheet* at 10 (indicating that NCS 2002 conforms to AT&T-specific requirements). The NCS 2000 Series network platform includes Raman amplifiers such as OPT-RAMP-C, OPT-RAMP-CE, and EDRA.

62. More specifically, the '922 Accused Instrumentalities, including the representative instrumentality, AT&T's fiber-optic network, provide a computerized method of controlling signal variation in an optical fiber comprising providing an optical fiber suitable for transmitting optical signals (e.g., optical fiber(s) connected between optical nodes, optical terminal units, and optical network units) in at least one signal wavelength range (e.g., 1529.0

nm to 1562.5 nm) and facilitating Raman gain in the at least one signal wavelength range. *See, e.g., Managing Network Connectivity* at Fig. 10 (showing multiple NCS Network Elements in an optical fiber network):

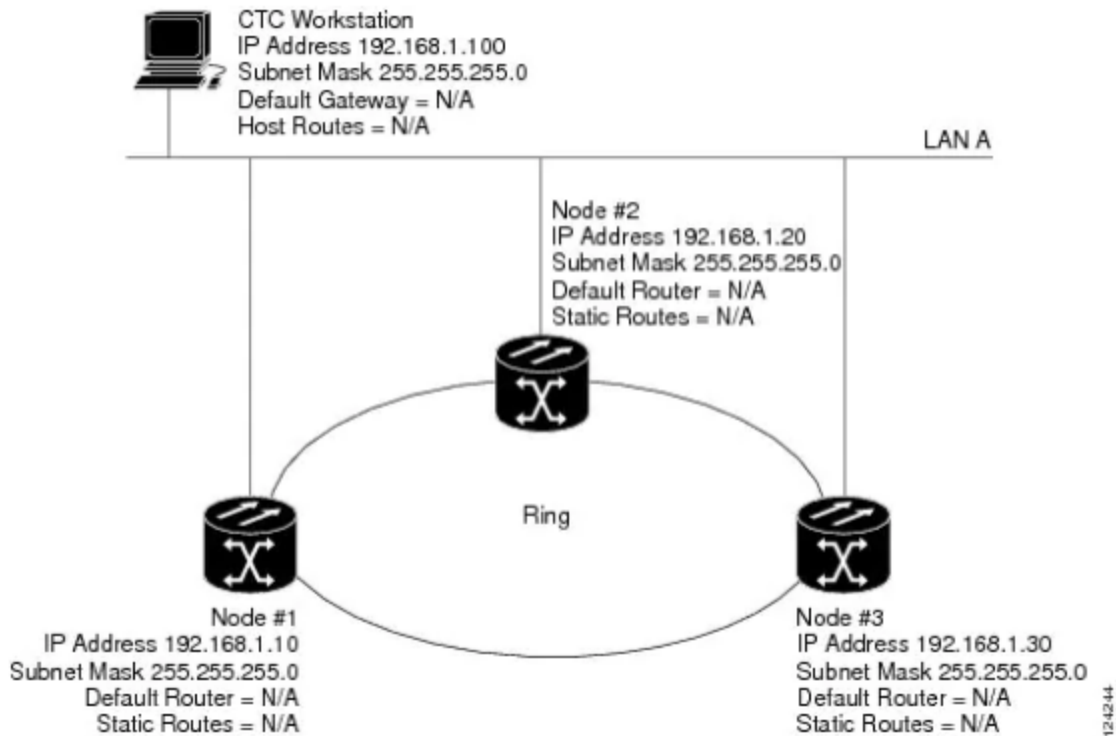
**Figure 10. Scenario 7: Proxy Server with GNE and ENEs on the Same Subnet (ANSI and ETSI)**



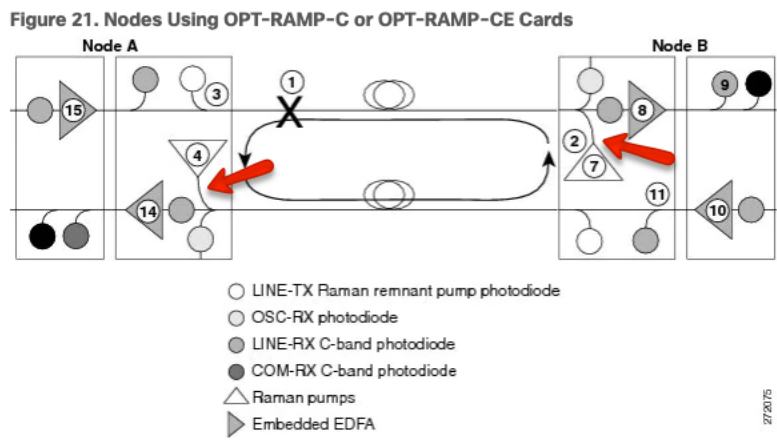
*See also id.* at Fig. 1 (showing NCS nodes connected to a LAN):



Figure 1. Scenario 1: CTC and NCS on Same Subnet (ANSI and ETSI)



See also **Network Reference** at Fig. 21 (annotated):

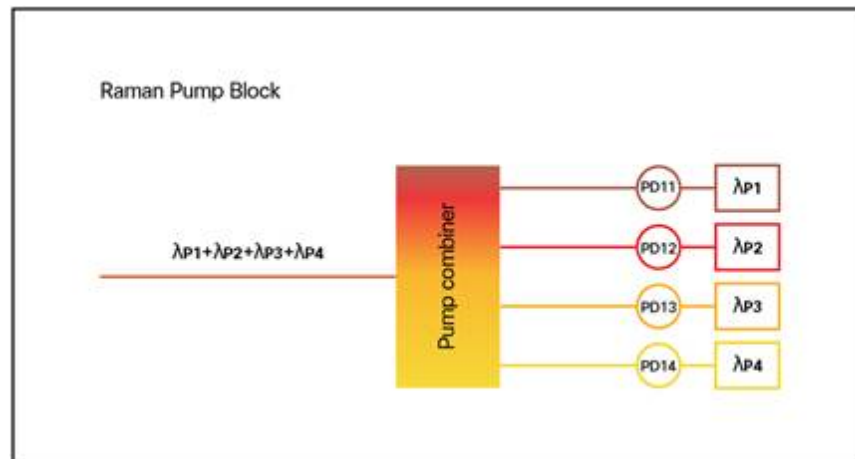


See, e.g., **NCS 2000 Datasheet** at 1 (“The Raman pump provides the following features (Figure

4): ● Total pump power of 1000 mW, consisting of four pumps over four wavelengths ●

Raman pump back-reflection detector to detect the amount of Raman pump power back-scattered by the LINE-RX connector and by the transmission fiber. ...”).

63. Also, the '922 Accused Instrumentalities, including the representative instrumentality, AT&T's fiber-optic network, couple a first pump source (e.g., any one or combination of P1/PD11, P2/PD12, P3/PD13, and P4/PD14) to the fiber to provide pump energy in a first set of Raman wavelengths including a plurality of pump wavelengths (e.g., any one or combination of  $\lambda_{P1}$ ,  $\lambda_{P2}$ ,  $\lambda_{P3}$ , and  $\lambda_{P4}$ ) having sufficient pump energy to produce Raman gain in the optical signal according to a signal variation profile in the signal wavelength range and a second pump source (e.g., any one or combination of P1/PD11, P2/PD12, P3/PD13, and P4/PD14) configured to provide pump energy in at least a second set of Raman wavelengths (e.g., any one or combination of  $\lambda_{P1}$ ,  $\lambda_{P2}$ ,  $\lambda_{P3}$ , and  $\lambda_{P4}$ ) to provide Raman gain in the first set of Raman wavelengths in said optical fiber. *See, e.g., NCS 2000 Datasheet* at 1 (“The Raman pump provides the following features (Figure 4): • Total pump power of 1000 mW, consisting of four pumps over four wavelengths”); *see also id.* at Fig. 4:



*See also id.* at Table 2:

**Table 2. Optical Specifications for Raman Section of Amplifier**

Parameter	Condition	Minimum	Typical	Maximum	Units
Pump 1 wavelength			1423		nm
Pump 2 wavelength			1434		nm
Pump 3 wavelength			1455		nm
Pump 4 wavelength			1470		nm
Pump spectral width			± 1	± 3	nm
Operating range of Raman pump power		100		1000	mW
Raman pump unit class at operative power	With system optical safety single hardware failure included (worst-case fault)			1M	-

See also **Node Reference** at 1 (“The Raman pump is equipped with two different Raman pumps transmitting powers (P1 and P2) at two different wavelengths Lambda1 and Lambda2. During installation, the two pumps alternatively turn ON and OFF at two different power values. Lambda1 and Lambda2 signals are used as probes at the end of spans to measure Raman gain efficiency of the two Raman pumps separately.”); see also *id.* at Table 12:

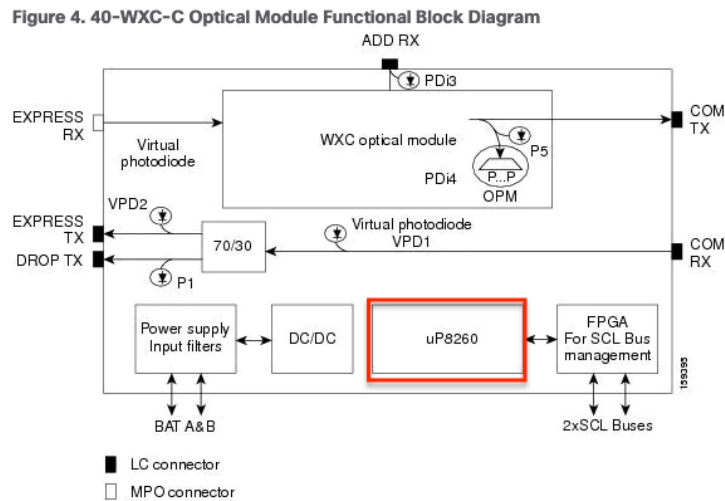
**Table 12. Example of Raman Power Measurements**

Input	P1	P2	Probe Signal Power Received at Node B
Lambda1=1530.33 nm at Node A	Plow = 100 mW	Pmin = 8 mW	S1low
	Phigh = 250 mW	Pmin = 8 mW	S1high
Lambda2=1560.61 nm at Node A	Pmin = 8 mW	Plow = 100 mW	S2low
	Pmin = 8 mW	Phigh = 250 mW	S2low

64. Further, the '922 Accused Instrumentalities, including the representative instrumentality, AT&T's fiber-optic network, monitor characteristics of the optical signals in a signal wavelength range passing through the optical fiber and controls the pump energy supplied by the at least one of the first and second pump sources in at least one of the pump wavelengths to vary the signal variation profile (e.g., from 8.5dB to 13.5dB) and Raman gain to provide Raman amplification, attenuation, and lossless transmission over the signal wavelength range in

the optical fiber. *See, e.g., Network Reference* at 1 (“Amplifiers monitor the changes to the input power and change the output power proportionately according to the calculated gain setpoint ... After the GEDFA is set, APC regulates the power on the VOA (DC-TX port) of the OPT-RAMP-C or OPT-RAMP-CE card to match the target Power (COM-TX port) value, and accounts for the actual DCU loss. ... The APC adjusts the VOA attenuation of the OPT-RAMP-C or OPT-RAMP-CE card if the Total Power (LINE-TX port) does not match the expected value that is equal to the maximum power multiplied by the number of active channels. The VOA attenuation value on the OPT-RAMP-C or OPT-RAMP-CE cards is set to 15 dB. This value ensures that the system turns up in any circumstance.”); *see also Raman C-Band Datasheet* at 1 (“The OPT-RAMP-C also provides an embedded fast Gain Control for transient suppression to respond quickly to network changes without impairments and degradation of existing wavelengths. In addition to this, the unit features an embedded Gain Flattening Filter (GFF) for the compensation of the ripple generated by the cascaded Raman and EDFA stages. The amplifier integrates a software-controllable variable optical attenuator (VOA) to provide gain tilt control capabilities and to optimize and control the per-channel power at the input of the mid-access loss for dispersion compensation units (DCUs). ... A dedicated software application has been incorporated in Cisco Transport Controller to allow a fully automatic and simple configuration and tuning of the optical Raman amplifiers along a DWDM link. This software application, called Raman Tuning Wizard, can take advantage of tunable Transponder or Muxponder units to evaluate the physical characteristics of the span’s fiber, determine the optimal mix of Raman pump wavelengths, and define the contribution of Raman versus EDFA for the overall optical amplification of the unit.”); *see also Node Reference* at 1 (“Automatic Raman Pump Calculation The Raman gain depends on the characteristics of the span (fiber type

and span loss). To obtain optimum Raman gain, a correct mix of pump powers must be provisioned. Tuning of the four Raman pumps is crucial before traffic is provisioned. The tuning procedure is called Automatic Raman Power Calculation (ARPC). This procedure assesses the Raman gain on a C-band signal using pre-defined Raman pump values. ARPC applies to the RAMAN-CTP and EDRA cards.”); *see also* **Release 10.x Optical Amplifier Cards** at 1 (showing a processor “uP2860” to monitor characteristics of the optical signals in a signal wavelength range passing through the optical fiber and control the pump energy) (annotated):



65. Discovery is expected to uncover the full extent of AT&T’s unlawful use of Optic153’s patented technology in the ’922 Patent beyond the ’922 Accused Instrumentalities already identified through public information.

66. On information and belief, AT&T’s also directly infringed at least Claim 32 of the ’922 Patent by testing the ’922 Accused Instrumentalities, including in relation to network testing and improvement responsive to user/customer feedback, and demonstration at trade shows, sales facilities, customer sites, and training/tutorial videos.

67. Plaintiff has suffered damages as a result of AT&T’s infringement of the ’922 Patent.

68. Plaintiff reserves the right to modify its infringement theories as discovery progresses in this case. Plaintiff shall not be estopped for purposes of its infringement contentions or its claim constructions by the foregoing discussions on how the '922 Accused Instrumentalities infringe the '922 Patent. Plaintiff intends only that the foregoing discussions satisfy the notice requirements of Rule 8(a)(2) of the Federal Rule of Civil Procedure, and that they should not be construed as Plaintiff's preliminary or final infringement contentions or preliminary or final claim construction positions.

**COUNT IV - INFRINGEMENT OF U.S. PATENT NO. 6,356,383**

69. Plaintiff incorporates and realleges the preceding paragraphs as if fully set forth herein.

70. The '383 Patent is directed to systems and methods for amplifying optical signals, as described and claimed in the '383 Patent.

71. AT&T directly infringed at least Claims 1-2 of the '383 Patent, in this judicial District and elsewhere in the United States, pursuant to 35 U.S.C. § 271(a), literally or under the doctrine of equivalents, by, among other things, by making, using, selling, offering to sell, and/or importing in or into the United States, without authority: products, devices, systems, and/or components of systems that counter-propagate and co-propagate optical energy to produce a desired Raman amplification (“'383 Accused Instrumentalities”). The '383 Accused Instrumentalities include, for example and without limitation, AT&T's optical communications networks and systems (e.g., AT&T fiber-optic network and fiber-to-the-premises network such as AT&T Fiber) that employ counter-propagating (e.g., Cisco Systems' 15454-M-RAMAN-CTP card) and co-propagating (e.g., 15454-M-RAMAN-COP card) Raman units including associated hardware and software, NCS 2000 Series network platform including associated hardware and





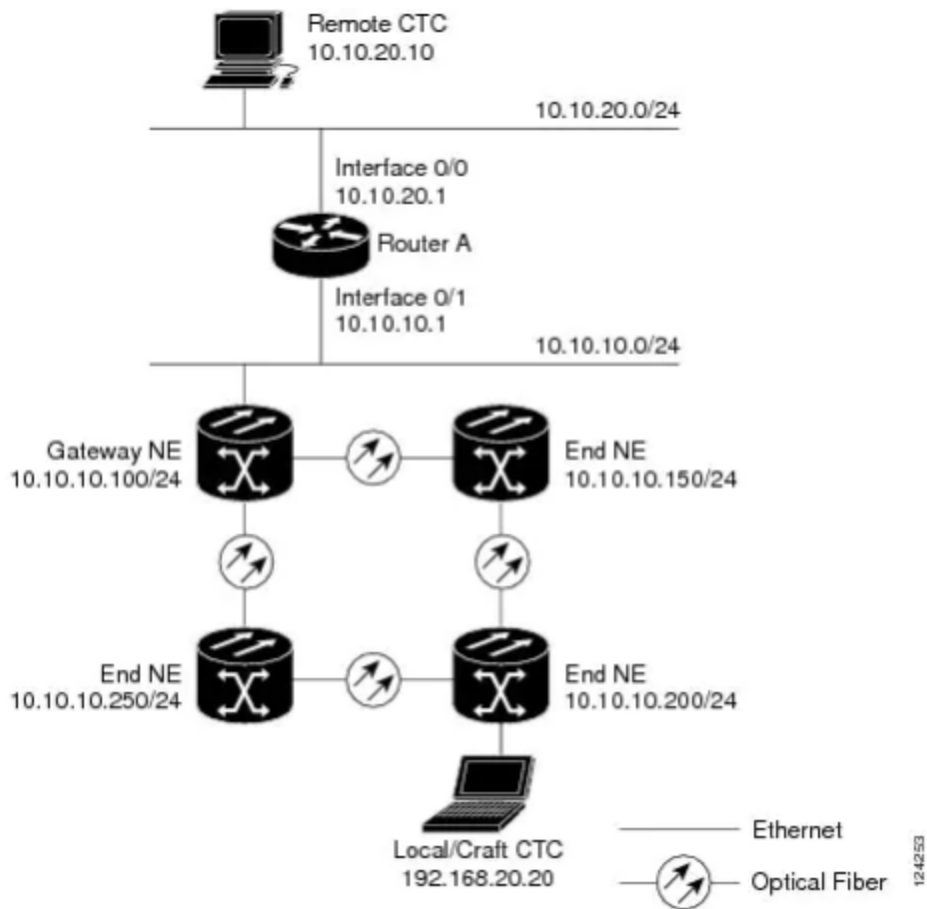
*See, e.g.*, “High Power Counter-Propagating and Co-Propagating Raman units for the Cisco ONS 15454 Multiservice Transport Platform (MSTP)” (“**15454 MSTP Datasheet**”) at 1, *available at* [https://www.cisco.com/c/en/us/products/collateral/optical-networking/ons-15454-series-multiservice-provisioning-platforms/data\\_sheet\\_c78-658538.html](https://www.cisco.com/c/en/us/products/collateral/optical-networking/ons-15454-series-multiservice-provisioning-platforms/data_sheet_c78-658538.html) (last visited Apr. 1, 2020).

73. More specifically, the ’383 Accused Instrumentalities, including the representative instrumentality, AT&T’s fiber-optic network, perform a method of amplifying optical signals comprising transmitting optical signals in a transmission media (e.g., optical fiber(s) connected between optical nodes, optical terminal units, and optical network units) configured to transmit and provide Raman amplification of the optical signals. *See, e.g.*

**Managing Network Connectivity** at Fig. 10 (showing multiple NCS network elements in a fiber optic network):

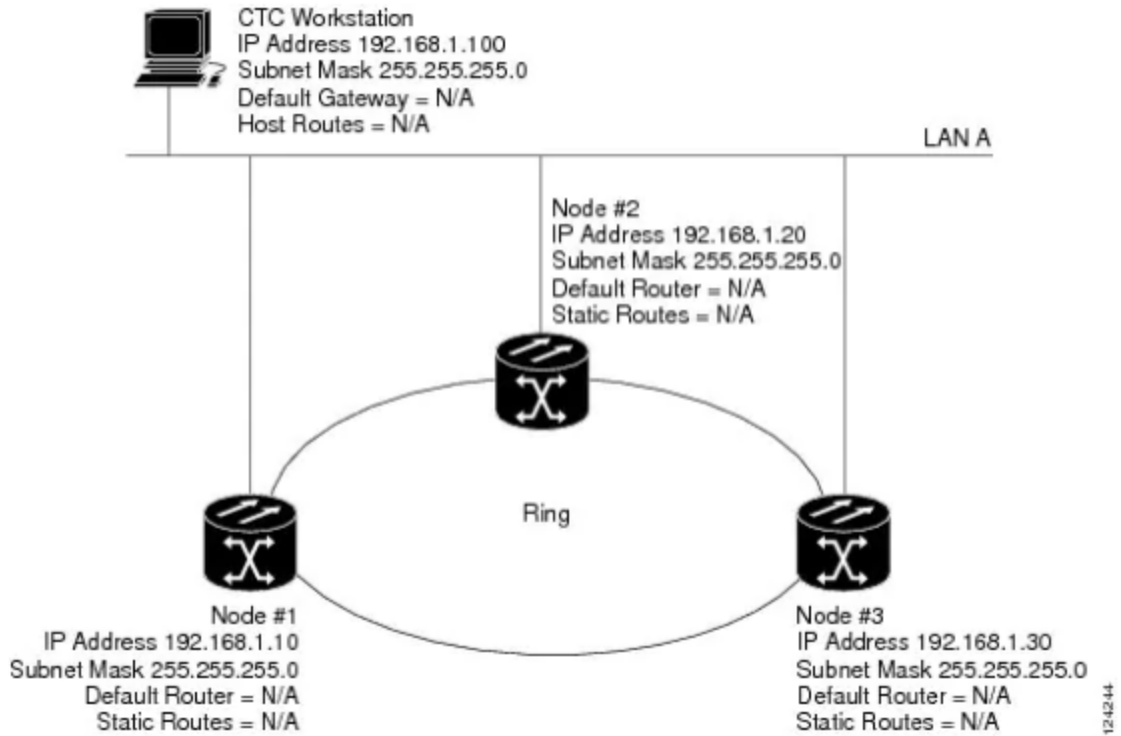


Figure 10. Scenario 7: Proxy Server with GNE and ENEs on the Same Subnet (ANSI and ETSI)



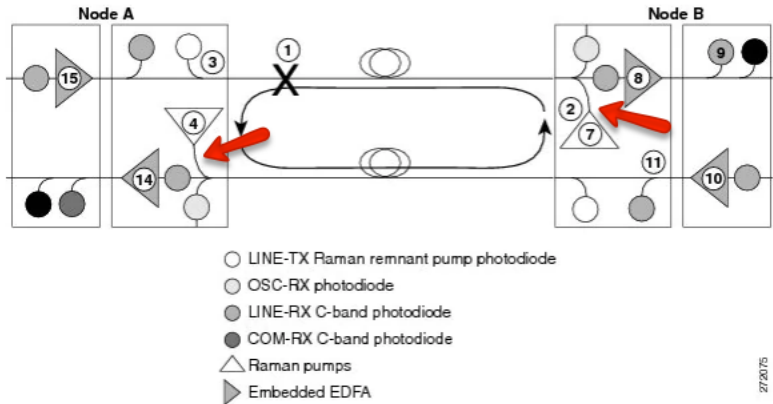
See also *id.* at Fig. 1 (showing NCS nodes connected to a LAN):

Figure 1. Scenario 1: CTC and NCS on Same Subnet (ANSI and ETSI)



See also **Network Reference** at Fig. 21 (annotated):

Figure 21. Nodes Using OPT-RAMP-C or OPT-RAMP-CE Cards



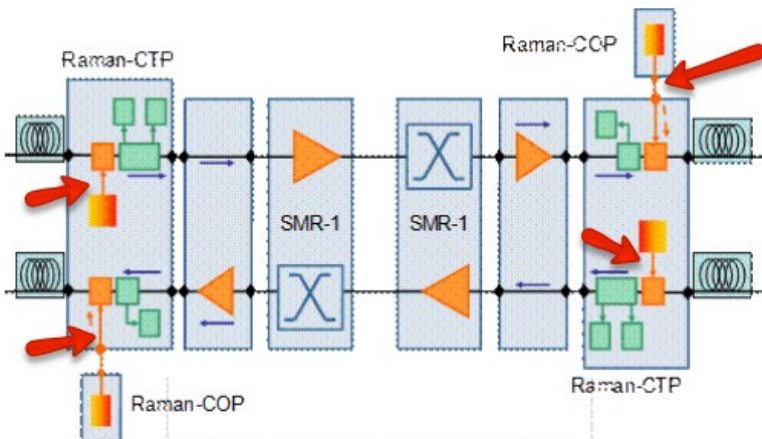
See also **NCS 2000 Datasheet** at 1 (“The Raman pump provides the following features (Figure

4): ● Total pump power of 1000 mW, consisting of four pumps over four wavelengths ●

Raman pump back-reflection detector to detect the amount of Raman pump power back-scattered

by the LINE-RX connector and by the transmission fiber. ...”); *see also* **15454 MSTP Datasheet** at 1 (“The high power counter-propagating unit injects counter-propagating optical power to generate a Raman effect in the span fiber and thus amplifies the signals propagating in the same fiber. Similarly, the co-propagating Raman unit injects co-propagating optical power that also amplifies the signal through a Raman effect in fiber. The signal thus receives amplification from the optical power injected by both these units present on opposite ends of the span”); *see also id.* at Fig. 5 (annotated):

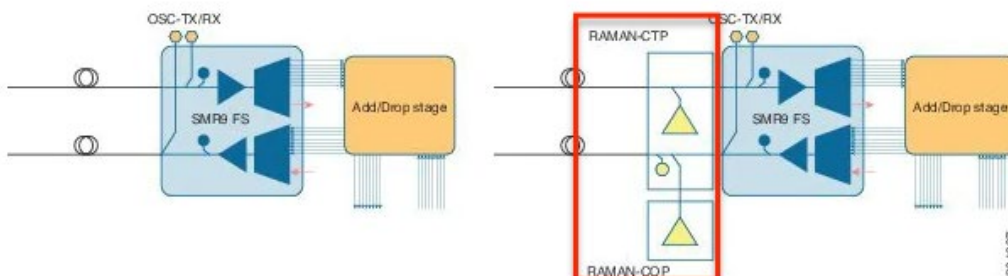
**Figure 5.** Equalization Stage with Single-Module ROADM 1 (SMR-1) and Counter-and Co-Propagating Raman Amplifiers



74. Also, the '383 Accused Instrumentalities, including the representative instrumentality, AT&T's fiber-optic network, counter-propagate optical energy in the transmission media in a first pump wavelength range (e.g., 1428 nm to 1457 nm or  $\zeta P1$  and  $\zeta P2$  via Pumps 1-4) to produce Raman amplification of the optical signals, wherein the Raman amplification has a corresponding noise figure profile over an optical signal wavelength range (e.g., 1500 to 1567 nm); and, co-propagate optical energy with the optical signals in a second pump wavelength range (e.g., 1428 nm to 1457 nm or  $\lambda P1$  and  $\lambda P2$  via Pumps 1-4) to vary the noise figure profile of the Raman amplification produced by said counter-propagating optical energy over at least a portion of the optical signal wavelength range. wherein said co-

propagating includes co-propagating optical energy in the second pump wavelength range that overlaps with shorter wavelengths in the first wavelength range (e.g., 1428 nm). See, e.g., **Node Reference** at FIG. 12:

**Figure 12. Terminal Node Configuration with SMR9 FS Card**



See also **Provisioning Optical Amplifier Cards** at 1 (annotated):

**RAMAN-CTP and RAMAN-COP Cards Power Monitoring**

Physical photodiodes P1 through P10 monitor the power for the RAMAN-CTP card.

**Table 2 RAMAN-CTP Port Calibration**

Photodiode	CTC Type Name	Calibrated to Port
P1	DFB in-fiber Output Power	LINE-TX
P2	DWDM RX Input Power	LINE-RX
P3	Pump 1 in-fiber Output Power	LINE-RX
P4	Pump 2 in-fiber Output Power	LINE-RX
P5	Total Pump in-fiber Output Power	LINE-RX
P6	Back-Reflected Pump Power	LINE-RX
P7	DWDM TX Input Power	COM-RX
P8	Total Co-Pump in-fiber Output Power	LINE-TX
P9	DFB Input Power	LINE-RX
P10	ASE Input Power	LINE-RX

Physical photodiodes P3 through P6 monitor the power for the RAMAN-COP card.

**Table 3 RAMAN-CTP Port Calibration**

Photodiode	CTC Type Name	Calibrated to Port
P3	Pump 1 in-fiber Output Power	RAMAN-TX
P4	Pump 2 in-fiber Output Power	RAMAN-TX
P5	Total Pump in-fiber Output Power	RAMAN-TX
P6	Back-Reflected Pump Power	RAMAN-TX

See also **15454 MSTP Datasheet** at Figs. 2-3:

Figure 2. Functional Block Diagram for the Cisco ONS 15454 MSTP High-Power Counter-Propagating Raman Amplifier

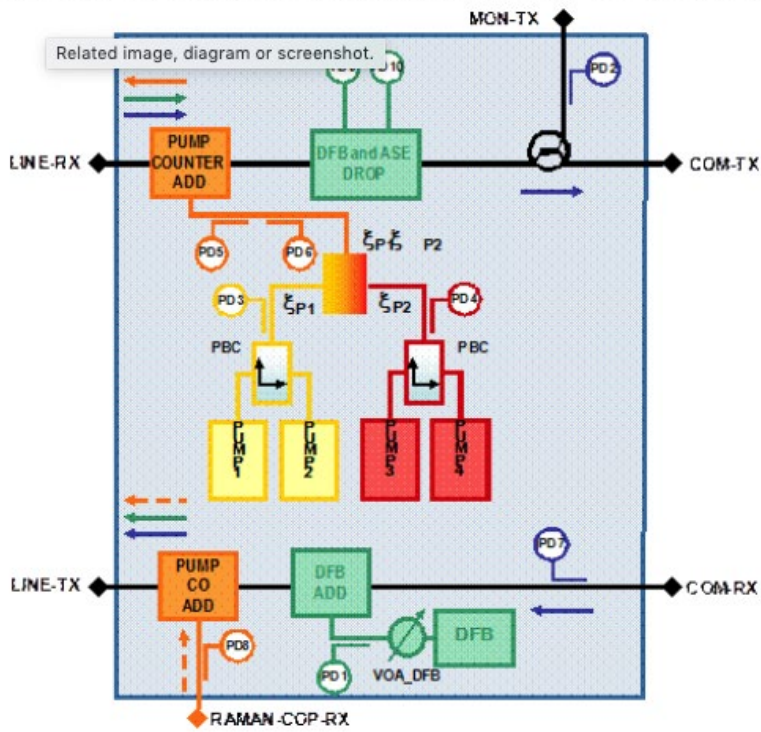
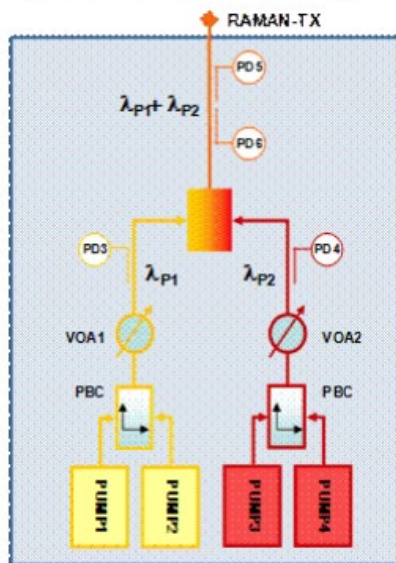


Figure 3. Functional Block Diagram for the Cisco ONS 15454 MSTP High-Power Co-Propagating Raman Amplifier



See also *id.* at Table 5:

**Table 5. Optical Amplifier Specifications**

Specification	Counter-Propagating Unit	Co-Propagating Unit
Pump wavelength	1428 nm (pumps 1 and 2) 1457 nm (pumps 3 and 4)	1428 nm (pumps 1 and 2) 1457 nm (pumps 3 and 4)
Raman pump unit class	1 M	1 M
Operating range Raman pump power	100 to 1000 mW	200 to 1000 mW
Maximum output power: pump laser 1+ 2 (1428 nm)	500 mW	550 mW
Maximum output power: pump laser 1+ 2 (1457 nm)	500 mW	500 mW
Pump-power set resolution	0.1 mW (maximum)	0.1 mW (maximum)
Pump-power precision	+ or - 2%	+ or - 2%
Optical power-settling time	0.1 to 1 sec	0.1 to 1 sec
Maximum optical output power - LINE Rx port	1200 mW (maximum)	1200 mW (maximum)
C-band signal wavelength range	1500 to 1567 nm (96 channels)	C-band wavelengths do not propagate through this card.

75. Further, the '383 Accused Instrumentalities, including the representative instrumentality, AT&T's fiber-optic network, transmit optical signals in a signal wavelength range from 1530-1570 nm; counter-propagate optical energy in the first pump wavelength range from 1410 to 1480 nm (e.g., from 1428 nm to 1457 nm); and co-propagate optical energy in the second pump wavelength range from 1410 to 1430 nm (e.g., from 1428 nm to 1457 nm). *See, e.g., 15454 MSTP Datasheet* at Table 5:

**Table 5. Optical Amplifier Specifications**

Specification	Counter-Propagating Unit	Co-Propagating Unit
Pump wavelength	1428 nm (pumps 1 and 2) 1457 nm (pumps 3 and 4)	1428 nm (pumps 1 and 2) 1457 nm (pumps 3 and 4)
Raman pump unit class	1 M	1 M
Operating range Raman pump power	100 to 1000 mW	200 to 1000 mW
Maximum output power: pump laser 1+ 2 (1428 nm)	500 mW	550 mW
Maximum output power: pump laser 1+ 2 (1457 nm)	500 mW	500 mW
Pump-power set resolution	0.1 mW (maximum)	0.1 mW (maximum)
Pump-power precision	+ or - 2%	+ or - 2%
Optical power-settling time	0.1 to 1 sec	0.1 to 1 sec
Maximum optical output power - LINE Rx port	1200 mW (maximum)	1200 mW (maximum)
C-band signal wavelength range	1500 to 1567 nm (96 channels)	C-band wavelengths do not propagate through this card.

76. Discovery is expected to uncover the full extent of AT&T's unlawful use of Optic153's patented technology in the '383 Patent beyond the '383 Accused Instrumentalities already identified through public information.

77. On information and belief, AT&T's also directly infringed at least Claims 1-2 of the '383 Patent by testing the '383 Accused Instrumentalities, including in relation to network testing and improvement responsive to user/customer feedback, and demonstration at trade shows, sales facilities, customer sites, and training/tutorial videos.

78. Plaintiff has suffered damages as a result of AT&T's infringement of the '383 Patent.

79. Plaintiff reserves the right to modify its infringement theories as discovery progresses in this case. Plaintiff shall not be estopped for purposes of its infringement contentions or its claim constructions by the foregoing discussions on how the '383 Accused Instrumentalities infringe the '383 Patent. Plaintiff intends only that the foregoing discussions satisfy the notice requirements of Rule 8(a)(2) of the Federal Rule of Civil Procedure, and that they should not be construed as Plaintiff's preliminary or final infringement contentions or preliminary or final claim construction positions.

**COUNT V - INFRINGEMENT OF U.S. PATENT NO. 6,587,261**

80. Plaintiff incorporates and realleges the preceding paragraphs as if fully set forth herein.

81. The '261 Patent is directed to systems and methods for amplifying optical signals, as described and claimed in the '261 Patent.

82. AT&T directly infringed at least Claims 1 and 10 of the '261 Patent, in this judicial District and elsewhere in the United States, pursuant to 35 U.S.C. § 271(a), literally or



under the doctrine of equivalents, by, among other things, by making, using, selling, offering to sell, and/or importing in or into the United States, without authority: products, devices, systems, and/or components of systems that supply optical energy in a plurality of pump wavelengths based on a characterized amplifier performance to control amplification signal wavelengths in an optical signal (“’261 Accused Instrumentalities”). The ’261 Accused Instrumentalities include, for example and without limitation, AT&T’s optical communications networks and systems (e.g., AT&T fiber-optic network and fiber-to-the-premises network such as AT&T Fiber) that employ Cisco’s NCS 2000 Series network platform including associated hardware and software, ONS 15454 Series platform including associated hardware and software, Fujitsu’s IFinity platforms including Flashwave 7500 and L130 CDC ROADM Blade including associated hardware and software, and/or other telecommunications networks and systems that deploy or have deployed such platforms or components.

83. By way of example, the representative instrumentality, AT&T’s fiber-optic network, employs Cisco’s NCS 2000 Series network platform and infringes the ’261 Patent. *See, e.g., NCS 2000 Series Data Sheet* at 10 (indicating that NCS 2002 conforms to AT&T-specific requirements). The NCS 2000 Series network platform includes erbium doped fiber amplifiers (e.g., OPT-AMP-xx-x and OPT-EDFA-xx,) and Raman amplifiers (e.g., OPT-RAMP-C, OPT-RAMP-CE, and EDRA-x-xx). *See, e.g., NCS 2000 Platform Data Sheet* at 1; *see also Provisioning Optical Amplifier Cards* at 1.

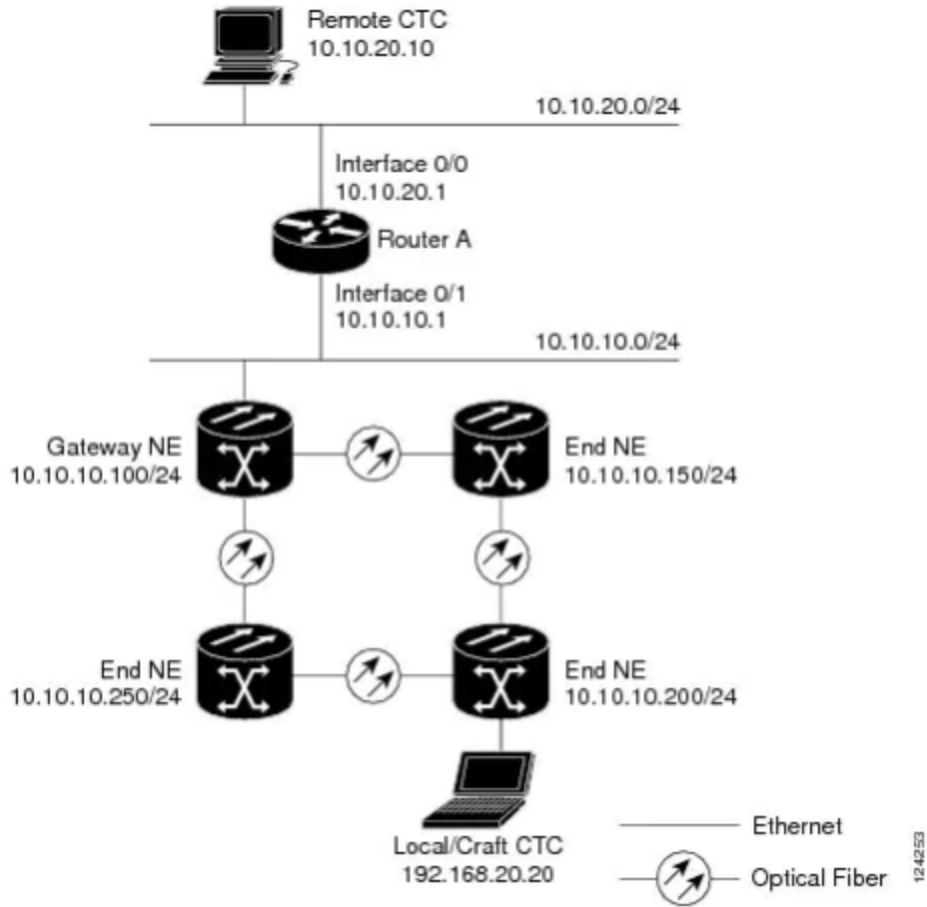
84. As another example, AT&T’s fiber-optic network, employs Fujitsu’s Flashwave 7500 since as early as 2011. *See, e.g., Fujitsu Wins Supplier Status* (“Fujitsu Network Communications has been selected as one of AT&T’s Domain Suppliers for optical and transport equipment. The multi-year selection covers equipment used to expand and maintain AT&T’s



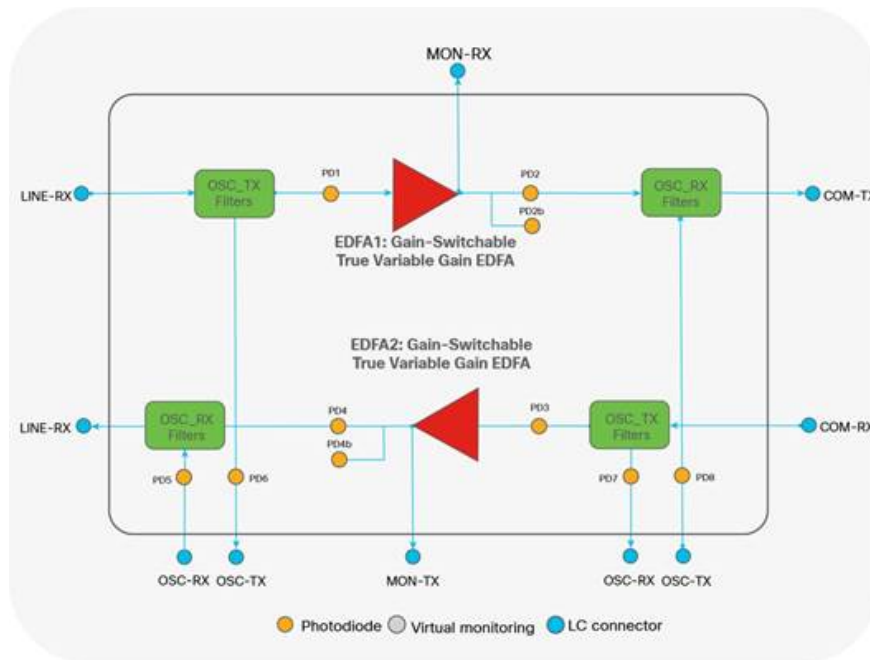
metropolitan and long-haul network infrastructure.”); *see also* **AT&T Milwaukee Business Journal** (“ The racks hold high-tech gizmos like the Fujitsu Flashwave 7500 that handle fiber optics carrying 80 circuits pumping information at 40 gigs a second, said telecommunications specialist Walter Spitzer, who runs the third floor and nicknamed the place “Wally’s World.”) The Flashwave 7500 employs EDFA and Raman amplifiers. *See* **Fujitsu’s Response to State of Utah** at 659 (“Raman Amplifiers • Raman Amplifiers Unit Interconnections • Dispersion Compensations • Shelf Hierarchy - HUB Node - ETSI Add/Drop Node Equipment - ETSI HUB Node Equipment with Raman Amplifiers.”); *see also* **Flashwave 7500 Small Systems Data Sheet** at 1 (“Optical Span Lengths • Point-to-point Up to 20 km • Point-to-point with EDFA Up to 100 km”).

85. More specifically, the ’261 Accused Instrumentalities, including the representative instrumentality, AT&T’s fiber-optic network, perform a method of amplifying optical signals comprising providing an optical amplifier (e.g., EDFA or Raman amplifiers) in an optical transmission fiber including an amplifying fiber configured to receive power as optical energy in a plurality of pump wavelengths. *See, e.g.,* **Managing Network Connectivity** at Fig 10 (showing NCS network elements in a fiber optic network):

Figure 10. Scenario 7: Proxy Server with GNE and ENEs on the Same Subnet (ANSI and ETSI)



See, e.g., Fig. 2 of NCS 2000 Platform Datasheet at 1 (showing the use of variable gain EDFAs):



See also **NCS 2000 Series Data Sheet** at 1 (listing all suitable optical amplifiers including OPT-EDFA-xx, EDRAx-xx, OPT-AMP-C, OPT-AMP-17C, M-RAMAN-CTP, and M-RAMAN-COP):

Optical Amplifiers	
15454-OPT-EDFA-17=	Enhanced C-band 96 channel low cost amplifier 17 dB max gain, 50 GHz compatible, LC connector, includes two 2m LC/LC fiber-optic cables
15454-OPT-EDFA-24=	Enhanced C-band 96 channel low cost amplifier 24 dB max gain, 50 GHz compatible, LC connector, includes two 2m LC/LC fiber-optic cables
NCS2K-EDRA1-26C=	21dBm Erbium Doped Raman Amplifier 26dB Span - C-Band, includes one 2m LC/LC fiber-optic cables and one 2m E2000/PC High power fiber optical cable
NCS2K-EDRA1-35C=	21dBm Erbium Doped Raman Amplifier 35dB Span - C-Band, includes one 2m LC/LC fiber-optic cable and one 2m E2000/PC High power fiber optical cable
NCS2K-EDRA2-26C=	21dBm Erbium Doped Raman Amplifier + Bst 26dB Span - C-Band, includes two 2m LC/LC fiber-optic cables and one 2m E2000/PC High power fiber optical cable
NCS2K-EDRA2-35C=	21dBm Erbium Doped Raman Amplifier + Bst 35dB Span - C-Band, includes two 2m LC/LC fiber-optic cables and one 2m E2000/PC High power fiber optical cable
15454-OPT-AMP-C=	ONS 15454 Enhanced Optical Amplifier, includes two 2m LC/LC fiber-optic cable and one LC/LC LOOPBACK
15454-OPT-AMP-17C=	17dB Gain, Amp, includes two 2m LC/LC fiber-optic cable and one LC/LC LOOPBACK
15454-M-RAMAN-CTP=	15454 MSTP - Raman Amplifier - C-band - Counter-Propagating, includes two 2m E2000/PC High power fiber optical cable
15454-M-RAMAN-COP=	15454 MSTP - Raman Amplifier - C-band - Co-Propagating, includes one 2m E2000/PC High power fiber optical cable

See also **Raman C-Band Datasheet** at 1 (“A Raman amplifier uses intrinsic properties of silica fibers to obtain signal amplification. This means that transmission fibers can be used as a medium for amplification, and hence that the intrinsic attenuation of data signals transmitted over the fiber can be combated within the fiber. An amplifier working on the basis of this

principle is commonly known as a distributed Raman amplifier (DRA) or simply Raman amplifier. The OPT-RAMP-C unit not only embeds efficient next-generation pump lasers to generate counter-propagating Raman effect in the span fiber but also a low-noise Erbium Doped Fiber Amplifier (EDFA) to optimize the overall Noise Figure of the Node.).

86. As another example, on information and belief, the 1Finity platforms, such as the Flashwave 7500 deployed in AT&T's fiber-optic network, provide an optical amplifier (e.g., EDFA or Raman amplifiers) in an optical transmission fiber including an amplifying fiber (e.g., the amplifying fiber connected to either the EDFA or Raman amplifiers) configured to receive power as optical energy in a plurality of pump wavelengths.

87. Also, the '261 Accused Instrumentalities, including the representative instrumentality, AT&T's fiber-optic network, characterize the amplifier performance for optical signals passing through the transmission fiber and amplifying fiber as a function of the optical energy provided in the plurality of pump wavelengths. *See, e.g., Network Reference* at 1 (“Amplifiers monitor the changes to the input power and change the output power proportionately according to the calculated gain setpoint.”); *see also id.* at Table 4 (monitoring input and output power of EDFA):

#### OPT-EDFA-17 and OPT-EDFA-24 Cards Power Monitoring

Physical photodiodes PD1 through PD6 monitor the power for the OPT-EDFA-17 and OPT-EDFA-24 cards.

**Table 4 OPT-EDFA-17 and OPT-EDFA-24 Port Calibration**

Photodiode	CTC Type Name	Calibrated to Port
P1	EDFA Input Power	COM-RX
P2	EDFA Output Power	LINE-TX
P3	EDFA Output Power	LINE-TX
P4	OSC ADD Input Power	OSC-RX
P5	OSC DROP Output Power	LINE-RX
P6	COM-TX Output Power	LINE-RX

*See also id.* at Table 5 (monitoring input and output power of EDRA):

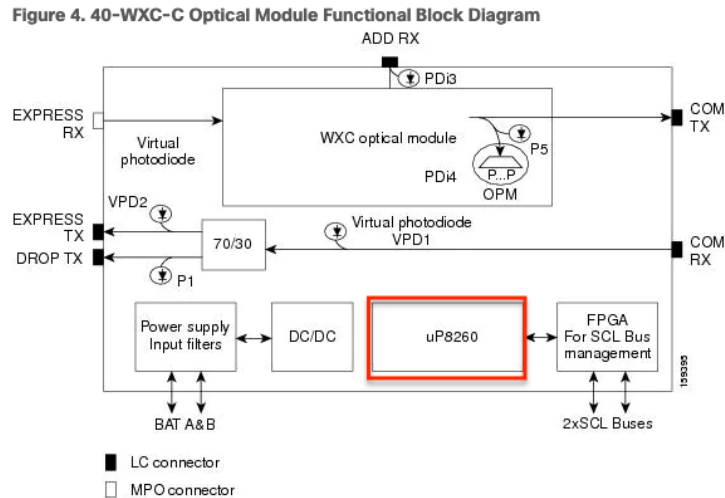
## EDRA-1-xx and EDRA-2-xx Cards Power Monitoring

The following table lists the physical photodiodes that monitor the power for the EDRA-1-xx and EDRA-2-xx cards.

**Table 5 EDRA-1-xx and EDRA-2-xx Port Calibration**

Photodiode	CTC Type Name	Calibrated to Port
PD1	Remnant Pump Input power	LINE-TX
PD2	OSC Add Input Power	OSC-RX
PD3	EDFA1 Input Power	LINE-RX
PD4	EDFA1 Output Power	COM-TX
PD5	EDFA2 Input Power	COM-RX
PD6	EDFA2/LINE-TX Output Power	LINE-TX
PD7	OSC Drop Output Power	LINE-TX
PD11	Pump $\lambda$ 1 in-fibre Output Power	LINE-RX
PD12	Pump $\lambda$ 2 in-fibre Output Power	LINE-RX
PD13	Pump $\lambda$ 3 in-fibre Output Power	LINE-RX
PD14	Pump $\lambda$ 4 in-fibre Output Power	LINE-RX
PD15	Total Pump in-fibre Output Power	LINE-RX
PD16	Back-Reflected Pump Power	LINE-RX
PD17	OTDR2-L Input Power	OTDR2-L-RX

*See NCS 2000 Platform Data Sheet* at 1 (“The amplifier also provides a fast-transient suppression to respond quickly to network changes without adding impairments and degradation. It also allows a programmable tilt and possess a non-distorting low-frequency transfer function. Each card integrates software-controllable Variable Optical Attenuators (VOAs) along with extensive optical monitoring with photo diodes, to provide nodal- and network-based automatic power-level management.”); *see also Release 10.x Optical Amplifier Cards* at 1 (showing a processor “uP2860” to characterize the amplifier performance for optical signals passing through the transmission fiber and amplifying fiber) (annotated):



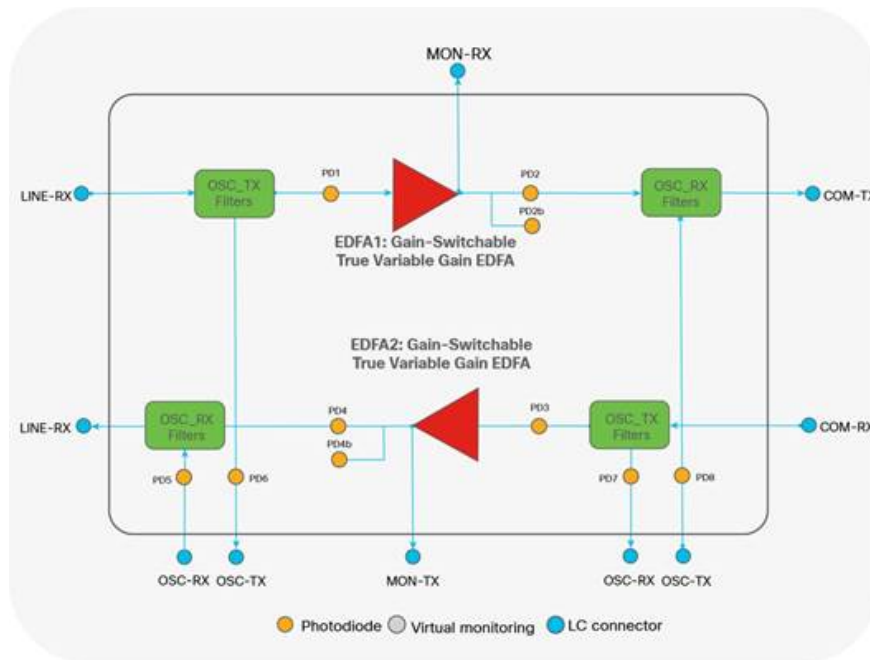
88. As another example, on information and belief, the 1Finity platforms, such as the Flashwave 7500 deployed in AT&T's fiber-optic network, characterize the amplifier performance for optical signals passing through the transmission fiber and amplifying fiber as a function of the optical energy provided in the plurality of pump wavelengths. *See 1Finity L130 Data Sheet* at 1; *see also 1Finity L160 Data Sheet* at 1.

89. Further, the '261 Accused Instrumentalities, including the representative instrumentality, AT&T's fiber-optic network, supply optical energy in the plurality of pump wavelengths in an amount based on the characterized amplifier performance (e.g., to reach target power) to control the amplification of a plurality of signal wavelengths included in the optical signal. *See, e.g., Network Reference* at 1 ("After the GEDFA is set, APC regulates the power on the VOA (DC-TX port) of the OPT-RAMP-C or OPT-RAMP-CE card to match the target Power (COM-TX port) value, and accounts for the actual DCU loss."); *see also Provisioning Optical Amplifier Cards* at 1 ("OPT-AMP-C Card ... Fixed output power mode (mode used during provisioning) ... ASE compensation in Constant Gain and Constant Output Power modes ... OPT-EDFA-17 and OPT-EDFA-24 Cards ... Constant gain mode ... ASE compensation in Constant Gain and Constant Output Power modes"); *Node Reference* at 1 ("The APC

dynamically adjusts the tilt reference (TILT REFERENCE) value to meet the target taking into consideration the Raman tilt (TILT RAMAN) that the Raman installation wizard calculates and the EDFA tilt (TILT EDFA) that is calculated by the OPT-RAMP-C or OPT-RAMP-CE card based on its GEDFA value: TILT CTP setpoint = TILT RAMAN + TILT EDFA + TILT REFERENCE”).

90. As another example, on information and belief, the 1Finity platforms, such as the Flashwave 7500 deployed in AT&T’s fiber-optic network, supply optical energy in the plurality of pump wavelengths in an amount based on the characterized amplifier performance to control the amplification of a plurality of signal wavelengths included in the optical signal. *See 1Finity L130 Data Sheet* at 1; *see also 1Finity L160 Data Sheet* at 1.

91. Further, the ’261 Accused Instrumentalities, including the representative instrumentality, AT&T’s fiber-optic network, perform a method of calibrating optical amplifier performance comprising installing an optical amplifier (e.g., EDFA or Raman amplifiers) in an optical transmission fiber. *See, e.g., Fig. 2 of NCS 2000 Platform Datasheet* at 1 (showing the use of variable gain EDFAs connected to transmission and reception fibers):



See also **NCS 2000 Series Data Sheet** at 1 (listing optical amplifiers including OPT-EDFA-xx, EDRAx-xx, OPT-AMP-C, OPT-AMP-17C, M-RAMAN-CTP, and M-RAMAN-COP that can be installed in an optical transmission fiber):

Optical Amplifiers	
15454-OPT-EDFA-17=	Enhanced C-band 96 channel low cost amplifier 17 dB max gain, 50 GHz compatible, LC connector, includes two 2m LC/LC fiber-optic cables
15454-OPT-EDFA-24=	Enhanced C-band 96 channel low cost amplifier 24 dB max gain, 50 GHz compatible, LC connector, includes two 2m LC/LC fiber-optic cables
NCS2K-EDRA1-26C=	21dBm Erbium Doped Raman Amplifier 26dB Span - C-Band, includes one 2m LC/LC fiber-optic cables and one 2m E2000/PC High power fiber optical cable
NCS2K-EDRA1-35C=	21dBm Erbium Doped Raman Amplifier 35dB Span - C-Band, includes one 2m LC/LC fiber-optic cable and one 2m E2000/PC High power fiber optical cable
NCS2K-EDRA2-26C=	21dBm Erbium Doped Raman Amplifier + Bst 26dB Span - C-Band, includes two 2m LC/LC fiber-optic cables and one 2m E2000/PC High power fiber optical cable
NCS2K-EDRA2-35C=	21dBm Erbium Doped Raman Amplifier + Bst 35dB Span - C-Band, includes two 2m LC/LC fiber-optic cables and one 2m E2000/PC High power fiber optical cable
15454-OPT-AMP-C=	ONS 15454 Enhanced Optical Amplifier, includes two 2m LC/LC fiber-optic cable and one LC/LC LOOPBACK
15454-OPT-AMP-17C=	17dB Gain, Amp, includes two 2m LC/LC fiber-optic cable and one LC/LC LOOPBACK
15454-M-RAMAN-CTP=	15454 MSTP - Raman Amplifier - C-band - Counter-Propagating, includes two 2m E2000/PC High power fiber optical cable
15454-M-RAMAN-COP=	15454 MSTP - Raman Amplifier - C-band - Co-Propagating, includes one 2m E2000/PC High power fiber optical cable

92. As another example, on information and belief, the IFinity platforms, such as the Flashwave 7500 deployed in AT&T’s fiber-optic network, perform a method of calibrating optical amplifier performance comprising installing an optical amplifier (e.g., EDFA or Raman



amplifiers) in an optical transmission fiber. *See 1Finity L130 Data Sheet* at 1; *see also 1Finity L160 Data Sheet* at 1.

93. Further, the '261 Accused Instrumentalities, including the representative instrumentality, AT&T's fiber-optic network, transmit test power through the transmission fiber and the optical amplifier and varying the power supplied to the optical amplifier. *See, e.g.*, "Cisco NCS 2000 Series Network Configuration Guide, Release 10.x.x, Chapter: Turning Up a Network," at Steps 8 and 9 of "Configure the Raman Pump Using the Installation Wizard" ("**Turning Up a Network**"), *available at* [https://www.cisco.com/c/en/us/td/docs/optical/15000r10\\_0/ncs/network\\_config/guide/b\\_ ncs\\_network\\_configuration/b\\_ ncs\\_network\\_configuration\\_chapter\\_01000.html](https://www.cisco.com/c/en/us/td/docs/optical/15000r10_0/ncs/network_config/guide/b_ ncs_network_configuration/b_ ncs_network_configuration_chapter_01000.html) (last visited Apr. 1, 2020) (turning on amplifiers and calibrating Raman amplification using a software installation wizard):

**Step 8** Click **Next**. The Calibrate Raman Page is displayed (**Figure 16-10**).

**Figure 10. Calibrating Raman Amplification**

**Step 9** As soon as the Raman calibrations are complete, the Next button is enabled. Click **Next**.

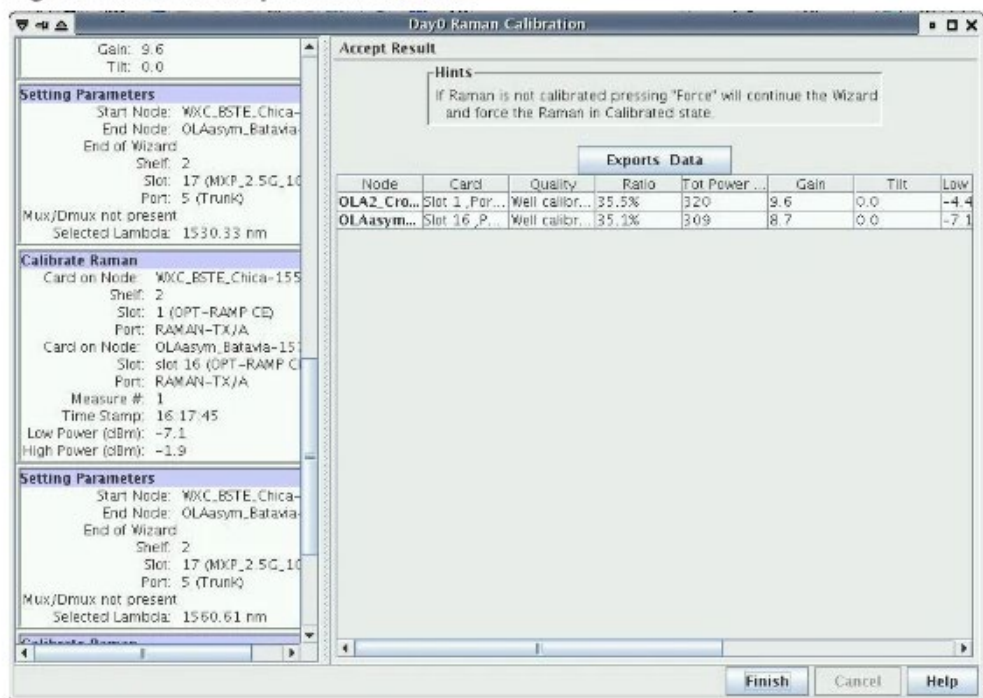
**Figure 11. Calibrating Raman Amplification**

94. As another example, on information and belief, the 1Finity platforms, such as the Flashwave 7500 deployed in AT&T’s fiber-optic network, transmit test power through the transmission fiber and the optical amplifier and vary the power supplied to the optical amplifier. *See 1Finity L130 Data Sheet* at 1; *see also 1Finity L160 Data Sheet* at 1.

95. The ’261 Accused Instrumentalities, including the representative instrumentality, AT&T’s fiber-optic network, measure the test power transmitted through the optical amplifier as a function of the power supplied to the optical amplifier; and, calculate amplifier performance parameters based on the measured test powers to characterize the amplification of a plurality of signal wavelengths as a function of the power supplied to the amplifier. *See, e.g., Turning Up a Network* at 1 (at Steps 12 and 13) of “Configure the Raman Pump Using the Installation Wizard” (measuring test power and calculating Raman gain):

**Step 12** Click Next. The Accept Results page is displayed (Figure 16-12).

**Figure 12. Raman Amplification Results**



The calculated Raman power and Raman gain are displayed. (Figure 16-12.)

*See also id.* at Step 13 (The wizard compares the calculated Raman gain value with the expected results. Your action depends on the Raman gain values: Expected gain (Gt) – 0.5 dB <= (gain) <= (expected gain) + 0.5 dB—If the Raman gain is within this range, it means that the setup procedure was successful. Go to Step 14. (Expected gain) - 3.0 dB <= (gain) <= (expected gain) – 0.5 dB—If the Raman gain is within this range, it means that the values are slightly outside the range. The wizard recommends that you verify the span length and cabling, and repeat the installation wizard procedure.”).

96. As another example, on information and belief, the IFinity platforms, such as the Flashwave 7500 deployed in AT&T’s fiber-optic network, measure the test power transmitted through the optical amplifier as a function of the power supplied to the optical amplifier; and, calculate amplifier performance parameters based on the measured test powers to characterize

the amplification of a plurality of signal wavelengths as a function of the power supplied to the amplifier. **1Finity L130 Data Sheet** at 1; *see also* **1Finity L160 Data Sheet** at 1.

97. Discovery is expected to uncover the full extent of AT&T's unlawful use of Optic153's patented technology in the '261 Patent beyond the '261 Accused Instrumentalities already identified through public information.

98. On information and belief, AT&T also directly infringed at least Claims 1 and 10 of the '261 Patent by testing the '261 Accused Instrumentalities, including in relation to network testing and improvement responsive to user/customer feedback, and demonstration at trade shows, sales facilities, customer sites, and training/tutorial videos.

99. Plaintiff has suffered damages as a result of AT&T's infringement of the '261 Patent.

100. Plaintiff reserves the right to modify its infringement theories as discovery progresses in this case. Plaintiff shall not be estopped for purposes of its infringement contentions or its claim constructions by the foregoing discussions on how the '261 Accused Instrumentalities infringe the '261 Patent. Plaintiff intends only that the foregoing discussions satisfy the notice requirements of Rule 8(a)(2) of the Federal Rule of Civil Procedure, and that they should not be construed as Plaintiff's preliminary or final infringement contentions or preliminary or final claim construction positions.

**COUNT VI - INFRINGEMENT OF U.S. PATENT NO. 6,771,413**

101. Plaintiff incorporates and realleges the preceding paragraphs as if fully set forth herein.

102. The '413 Patent is directed to systems and methods for transmitting optical signals, as described and claimed in the '413 Patent.

103. AT&T directly infringed at least Claims 1 and 10 of the '413 Patent, in this judicial District and elsewhere in the United States, pursuant to 35 U.S.C. § 271(a), literally or under the doctrine of equivalents, by, among other things, by making, using, selling, offering to sell, and/or importing in or into the United States, without authority: products, devices, systems, and/or components of systems that counter pump and co-pump optical energy to produce Raman amplification in an optical fiber (“'413 Accused Instrumentalities”). The '413 Accused Instrumentalities include, for example and without limitation, AT&T's optical communications networks and systems (e.g., AT&T fiber-optic network and fiber-to-the-premises network such as AT&T Fiber) that employ counter-propagating (e.g., Cisco's 15454-M-RAMAN-CTP card) and co-propagating (e.g., 15454-M-RAMAN-COP card) Raman units including associated hardware and software, NCS 2000 Series network platform including associated hardware and software, ONS 15454 Series platform including associated hardware and software, and/or other telecommunications networks and systems that deploy or have deployed such platforms or components.

104. By way of example, the representative instrumentality, AT&T's fiber-optic network, employs Cisco's NCS 2000 Series network platform and infringes the '413 Patent. *See, e.g., NCS 2000 Series Data Sheet* at 10 (indicating that NCS 2002 conforms to AT&T-specific requirements). The NCS 2000 Series network platform includes Raman amplifiers such as RAMAN-CTP, RAMAN-COP, 15454-M-RAMAN-CTP card, and 15454-M-RAMAN-COP card to amplify optical signals and to provide signal co-propagation and counter-propagation. An image of the RAMAN-CTP and RAMAN-COP is shown below:



105. More specifically, the '413 Accused Instrumentalities, including the representative instrumentality, AT&T's fiber-optic network, perform a method of transmitting optical signals comprising transmitting optical signals, in an optical signal wavelength range (e.g., 1500 to 1567 nm), via a transmission media (e.g., an optical fiber) and amplifying the optical signals a plurality of times at a plurality of separate locations (e.g., where the counter-propagating and co-propagating amplifiers are located along the transmission) to produce a composite optical signal gain profile, wherein amplifying includes counter pumping optical energy in the transmission media in a first pump wavelength range (e.g., 1428 nm to 1457 nm or  $\zeta P1$  and  $\zeta P2$  via Pumps 1-4) and co-pumping optical energy in the transmission media in a second pump wavelength range (e.g., 1428 nm to 1457 nm or  $\lambda P1$  and  $\lambda P2$  via Pumps 1-4) to produce Raman amplification of the optical signals. See **15454 MSTP Datasheet** at 1 ("The high power counter-propagating unit injects counter-propagating optical power to generate a Raman effect in the span fiber and thus amplifies the signals propagating in the same fiber. Similarly, the co-propagating Raman unit injects co-propagating optical power that also amplifies the signal through a Raman effect in fiber. The signal thus receives amplification from the optical power injected by both these units present on opposite ends of the span"); see also *id.* at Figs. 2 and 3:



Figure 2. Functional Block Diagram for the Cisco ONS 15454 MSTP High-Power Counter-Propagating Raman Amplifier

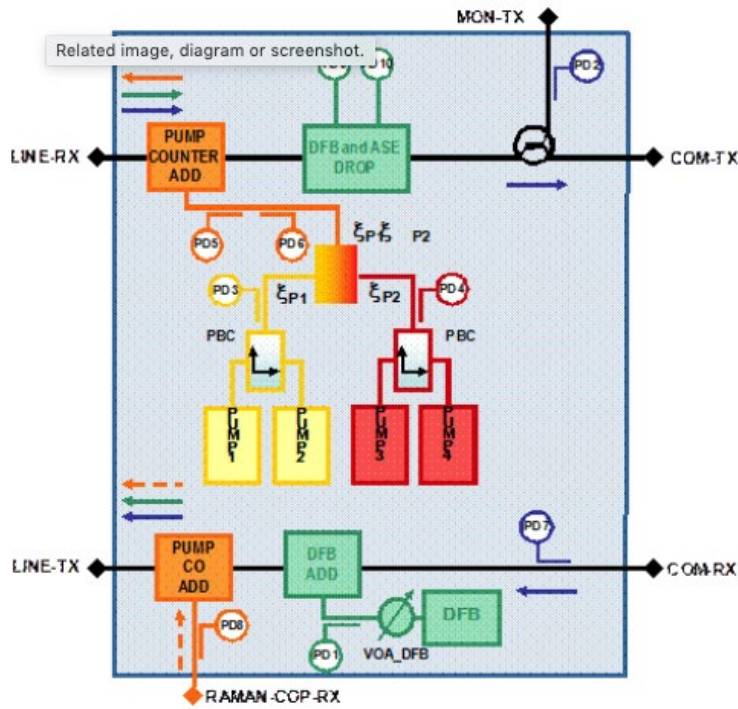
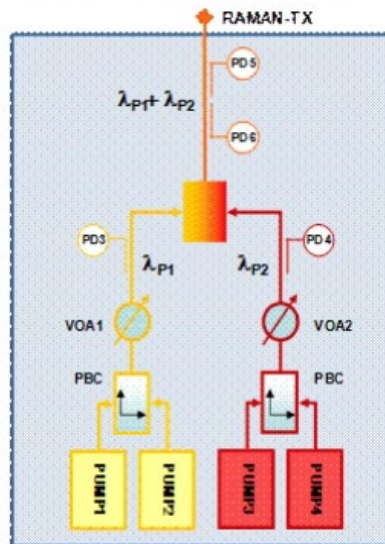


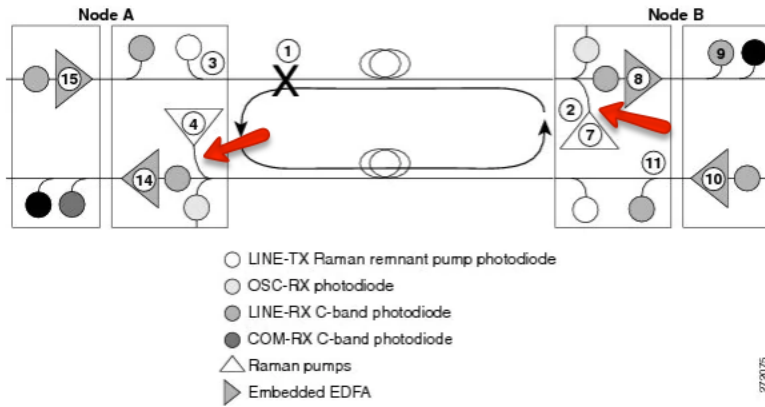
Figure 3. Functional Block Diagram for the Cisco ONS 15454 MSTP High-Power Co-Propagating Raman Amplifier



See also Network Reference at Fig. 21 (annotated):

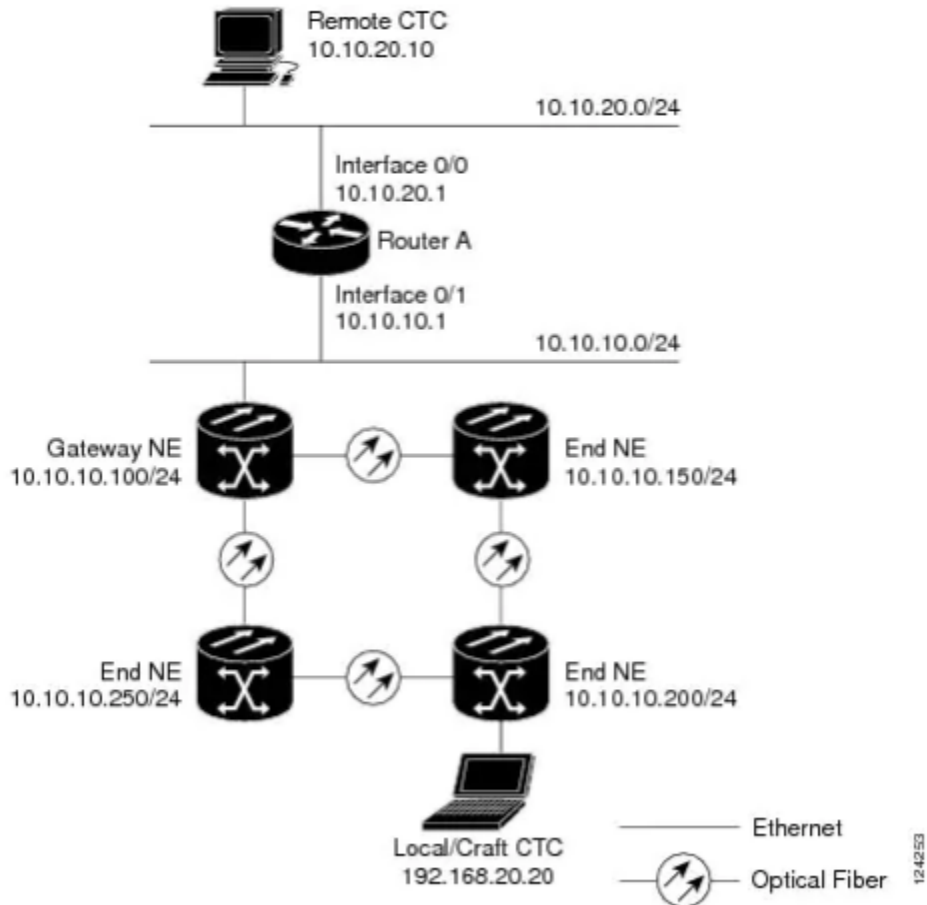


Figure 21. Nodes Using OPT-RAMP-C or OPT-RAMP-CE Cards



See also **Managing Network Connectivity** at 10 (showing NCS network elements in a fiber optic network):

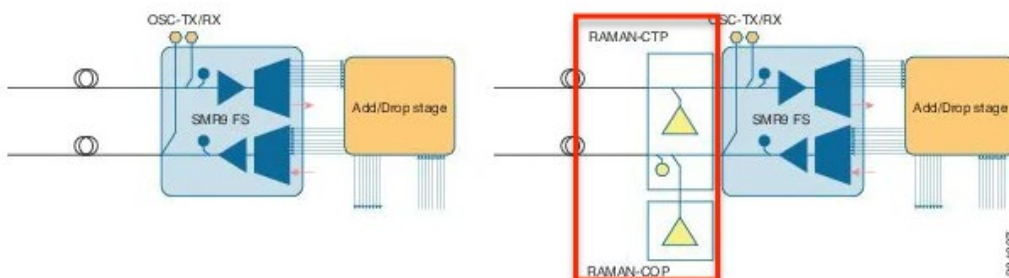
Figure 10. Scenario 7: Proxy Server with GNE and ENEs on the Same Subnet (ANSI and ETSI)



*See also NCS 2000 Datasheet* at 1 (“The Raman pump provides the following features (Figure 4): ● Total pump power of 1000 mW, consisting of four pumps over four wavelengths ● Raman pump back-reflection detector to detect the amount of Raman pump power back-scattered by the LINE-RX connector and by the transmission fiber. ...”).

106. Also, the '413 Accused Instrumentalities, including the representative instrumentality, AT&T's fiber-optic network, counter pump to produce a counter pumping noise figure profile (e.g., as created by  $\zeta P1$  and  $\zeta P2$  via Pumps 1-4) over the optical signal wavelength range corresponding to the Raman amplification and co-pump to vary the counter pumping noise figure profile over at least a portion of the optical signal wavelength range (e.g., as created by  $\lambda P1$  and  $\lambda P2$  via Pumps 1-4). *See also* “Practical Aspects of Raman Amplifier,” available at <https://www.cisco.com/c/en/us/support/docs/optical-networking/ons-15454-m6-multiservice-transport-platform-mstp/212834-practical-aspects-of-raman-amplifier.html> (last visited Apr. 1, 2020) (“Noise Sources Noise created in a DRA span consists: Amplified Spontaneous Emissions (ASE) Double Rayleigh Scattering (DRS) Pump Laser Noise ASE noise is due to photon generation by spontaneous Raman scattering. DRS noise occurs when twice reflected signal power due to Rayleigh scattering is amplified and interferes with the original signal as crosstalk noise. ... Counter pump DRA configuration results in better OSNR performance for signal gains of 15 dB and greater. ... For fibers with low DRS noise, the Raman noise figure due to ASE is much better than the EDFA noise figure. Typically, the Raman noise figure is -2 to 0 dB, which is about 6 dB better than the EDFA noise figure.”); *see also Node Reference* at FIG. 12:

**Figure 12. Terminal Node Configuration with SMR9 FS Card**



See also **Provisioning Optical Amplifier Cards** at 1 (annotated):

**RAMAN-CTP and RAMAN-COP Cards Power Monitoring**

Physical photodiodes P1 through P10 monitor the power for the RAMAN-CTP card.

**Table 2 RAMAN-CTP Port Calibration**

Photodiode	CTC Type Name	Calibrated to Port
P1	DFB in-fiber Output Power	LINE-TX
P2	DWDM RX Input Power	LINE-RX
P3	Pump 1 in-fiber Output Power	LINE-RX
P4	Pump 2 in-fiber Output Power	LINE-RX
P5	Total Pump in-fiber Output Power	LINE-RX
P6	Back-Reflected Pump Power	LINE-RX
P7	DWDM TX Input Power	COM-RX
P8	Total Co-Pump in-fiber Output Power	LINE-TX
P9	DFB Input Power	LINE-RX
P10	ASE Input Power	LINE-RX

Physical photodiodes P3 through P6 monitor the power for the RAMAN-COP card.

**Table 3 RAMAN-CTP Port Calibration**

Photodiode	CTC Type Name	Calibrated to Port
P3	Pump 1 in-fiber Output Power	RAMAN-TX
P4	Pump 2 in-fiber Output Power	RAMAN-TX
P5	Total Pump in-fiber Output Power	RAMAN-TX
P6	Back-Reflected Pump Power	RAMAN-TX

107. Also, the '413 Accused Instrumentalities, including the representative instrumentality, AT&T's fiber-optic network, filter the composite optical signal gain profile produced by amplifying the optical signal a plurality of times (e.g., through a series of amplifiers) to produce a desired gain profile for the optical signals. See also **15454 MSTP**

**Datasheet** at 1 (“To equalize the Raman gain ripple, the high-power Raman amplifiers must be equipped in nodes with equalization ability: either a dynamic gain-equalizer (DGE) node or a reconfigurable optical add/drop multiplexing (ROADM) node. Multiple options are possible and are detailed in Figures 4 through 6.”).

108. On information and belief, the '413 Accused Instrumentalities, including the representative instrumentality, AT&T's fiber-optic network, produce a desired gain profile that is a flat gain profile (e.g., a constant gain). *See, e.g.*, Practical Aspects of Raman Amplifier at 1:

$$G_{R.on/off} = 10 \log \left( \frac{P_s(\text{pump.on,signal.on}) - P_{\text{noise}}(\text{pump.on,signal.off})}{P_s(\text{pump.off,signal.on})} \right)$$

*See also Provisioning Optical Amplifier Cards* at 1 (“The features of the OPT-RAMP-C and OPT-RAMP-CE card include: ... Gain Flattening Filter (GFF) for Raman plus EDFA ripple compensation”).

109. Discovery is expected to uncover the full extent of AT&T's unlawful use of Optic153's patented technology in the '413 Patent beyond the '413 Accused Instrumentalities already identified through public information.

110. On information and belief, AT&T also directly infringed at least Claims 1 and 10 of the '413 Patent by using the '413 Accused Instrumentalities, including in relation to product testing and improvement responsive to user/customer feedback, and demonstration at trade shows, sales facilities, customer sites, and training/tutorial videos.

111. Plaintiff has suffered damages as a result of AT&T infringement of the '413 Patent.

112. Plaintiff reserves the right to modify its infringement theories as discovery

progresses in this case. Plaintiff shall not be estopped for purposes of its infringement contentions or its claim constructions by the foregoing discussions on how the '413 Accused Instrumentalities infringe the '413 Patent. Plaintiff intends only that the foregoing discussions satisfy the notice requirements of Rule 8(a)(2) of the Federal Rule of Civil Procedure, and that they should not be construed as Plaintiff's preliminary or final infringement contentions or preliminary or final claim construction positions.

**PRAYER FOR RELIEF**

WHEREFORE, Plaintiff demands judgment for itself and against Defendant AT&T as follows:

- A. A judgment that Defendant has infringed one or more claims of each of the Asserted Patents;
- B. A judgment awarding Plaintiff all damages adequate to compensate for Defendant's infringement, and in no event less than a reasonable royalty for Defendant's acts of infringement, including all pre-judgment and post-judgment interest at the maximum rate allowed by law;
- C. A judgment and order finding that this is an exceptional case within the meaning of 35 U.S.C. § 285 and awarding Plaintiff its reasonable attorneys' fees; and
- D. A judgment awarding Plaintiff such other relief as the Court may deem just and equitable.

**DEMAND FOR JURY TRIAL**

Pursuant to Rule 38(b) of the Federal Rules of Civil Procedure, Plaintiff demands a trial by jury of this action.

Dated: January 29, 2021

DEVLIN LAW FIRM LLC

/s/ Timothy Devlin

Timothy Devlin (*pro hac vice application pending*)

tdevlin@devlinlawfirm.com

Alex Chan

Texas State Bar No. 24108051

achan@devlinlawfirm.com

1526 Gilpin Ave.

Wilmington, Delaware 19806

Telephone: (302) 449-9010

Facsimile: (302) 353-4251

*Attorneys for Plaintiff,*

*Optic153 LLC.*