

**IN THE UNITED STATES DISTRICT COURT
FOR THE WESTERN DISTRICT OF TEXAS
WACO DIVISION**

OPTIC153 LLC,

Plaintiff,

v.

CHARTER COMMUNICATIONS, INC.,
TIME WARNER CABLE INFORMATION
SERVICES (TEXAS), LLC, SPECTRUM
MOBILE, LLC, and SPECTRUM MOBILE
EQUIPMENT, LLC

Defendants.

Civil Action No. 6:21-cv-89

JURY TRIAL DEMANDED

COMPLAINT FOR PATENT INFRINGEMENT

Plaintiff Optic153 LLC (“Plaintiff” or “Optic153”) hereby alleges as follows against Charter Communications, Inc, Time Warner Cable Information Services (Texas), LLC, Spectrum Mobile, LLC and Spectrum Mobile Equipment, LLC (collectively “Charter” or “Defendants”):

NATURE OF THE ACTION

1. This is an action for patent infringement arising under the Patent Laws of the United States, 35 U.S.C. § 1 *et seq.*

THE PARTIES

2. Plaintiff is a limited liability companies organized under the laws of the State of Delaware and has a place of business at 356 Greenwood Court, Villanova, PA, 19085.

3. Defendant Charter Communications, Inc. (“Charter Communications”) is a Delaware corporation with a principal place of business at 400 Atlantic Street, Stamford, CT 06901. Charter Communications may be served through its registered agent for service in Texas,

Corporation Service Company d/b/a CSC – Lawyers Incorporating Service Company, 211 E. 7th Street, Suite 620, Austin, TX 78701.

4. Defendant Time Warner Cable Information Services (Texas), LLC (“Time Warner Texas”) is a Delaware limited liability company with a mailing address at 12405 Powerscourt Dr. c/o Tax Dept. Saint Louis, MO 63131-3673. On information and belief, Time Warner Texas is a subsidiary of Charter Communications. Time Warner Texas may be served through its registered agent for service in Texas, Corporation Service Company d/b/a CSC – Lawyers Incorporating Service Company, 211 E. 7th Street, Suite 620, Austin, TX 78701.

5. Defendant Spectrum Mobile, LLC (“Spectrum Mobile”) is a Delaware limited liability company with a mailing address at 12405 Powerscourt Dr. c/o Tax Dept. Saint Louis, MO 63131-3673. Spectrum Mobile may be served through its registered agent for service in Texas, Corporation Service Company d/b/a CSC – Lawyers Incorporating Service Company, 211 E. 7th Street, Suite 620, Austin, TX 78701. On information and belief, Spectrum Mobile is a subsidiary of Charter Communications.

6. Defendant Spectrum Mobile Equipment, LLC (“Spectrum Mobile Equipment”) is a Delaware limited liability company with a mailing address at 12405 Powerscourt Dr. c/o Tax Dept. Saint Louis, MO 63131-3673. Spectrum Mobile Equipment may be served through its registered agent for service in Texas, Corporation Service Company d/b/a CSC – Lawyers Incorporating Service Company, 211 E. 7th Street, Suite 620, Austin, TX 78701. On information and belief, Spectrum Mobile Equipment is a subsidiary of Charter Communications.

7. Charter Communications, Time Warner Texas, Spectrum Mobile and Spectrum Mobile Equipment (collectively, “Charter” or “Defendant”) operates and/or employs, either directly or indirectly, optical telecommunications networks in the United States.

8. Charter operates and/or employs, or has operated or employed, either directly or indirectly, optical communications networks that utilize EDFAs and/or Raman amplifiers to controllably produce Raman amplification, attenuation and/or lossless transmission in said networks.

9. The optical communications networks operated and/or employed by Charter have deployed at least Cisco's multiservice platforms (e.g., ONS 15454) in addition to other components that are connected to these devices for the purpose of transmitting voice and data traffic.

10. The optical communications networks operated and/or employed by Charter utilize the functionality of the foregoing systems and devices in a manner designed to facilitate the transmission and reception of voice and data during the normal operation of such networks.

JURISDICTION AND VENUE

11. This is an action for patent infringement arising under the Patent Laws of the United States, 35 U.S.C. § 1, *et seq.*

12. This Court has subject matter jurisdiction under 28 U.S.C. §§ 1331 and 1338(a).

13. The Court has personal jurisdiction over Charter at least because Charter has continuous business contacts in the State of Texas and in this District. Charter has engaged in business activities including transacting business in this District and purposefully directing its business activities, including the provision of infringing communications networks and services, in this District, and the sale or offer for sale of services and goods in this District. For example, Charter—either directly or through those acting on its behalf—offers infringing communications networks and services in this District *See, e.g.*, <https://broadbandnow.com/Charter-Communications>.

14. Charter conducts business operations within the Western District of Texas. Charter maintains several facilities in this District, including its facilities at 1000 East 41st Street, Suite 920, Austin, Texas 78751; 11920 Alterra Parkway, Suite 134, Austin, Texas 78758; 730 Stassney Lane, Suite 100, Austin, Texas 78758; 1325 George Dieter, Suites CE02 & CE03, El Paso, Texas 79936; and 7010 Airport Road, El Paso, Texas 79906. Charter has offices in the Western District of Texas where it sells, develops, and/or markets its products including sales and service offices located in, among other cities within this District, Waco, Austin, and El Paso

15. As another example, Charter—either directly or through those acting on its behalf—has regular and established places of business in this District in which infringing communications networks and services are designed, developed, or offered for sale. *See, e.g.*, <https://www.spectrum.com/stores>. For example, Charter, through each of the named parties, has various regular and established places of business within this District, including facilities located at 215 Factory Dr., Waco, TX 76710; 6510 North Mesa, El Paso, TX 79912; 7010 Airport Rd., El Paso, TX 79906; 1109 E 5th Street, Block 3, Austin, TX 78702; 1000 E 41st St., Suite 920, Austin, TX 78751; 1000 East 41st Street, Suite 920, Austin, Texas 78751; 11920 Alterra Parkway, Suite 134, Austin, Texas 78758; 730 Stassney Lane, Suite 100, Austin, Texas 78758; 1325 George Dieter, Suites CE02 & CE03, El Paso, Texas 79936; 7010 Airport Road, El Paso, Texas 79906; and 3151 SE Military Dr., Suite 101, San Antonio, TX 78223. Charter also operates Spectrum News 1, a news service with a newsroom located at 1708 Colorado St., Austin, TX 78701. Charter also offers telecommunications services to “state and local government, public education, and other public entities in Texas” through the Texas Department of Information Resources in Austin. *See, e.g.*, <https://dir.texas.gov/View-Search/Contracts-Detail.aspx?contractnumber=DIR-TEX-AN-NG-CTSA-008>.

16. Venue is proper in this district under 28 U.S.C. §§ 1391(b)-(d) and 1400(b). Defendant Charter is registered to do business in the State of Texas, has offices in the State of Texas, has transacted business in the Western District of Texas, and has committed acts of direct and indirect infringement in the Western District of Texas.

17. Venue is proper in this District pursuant to 28 U.S.C. § 1400(b). On information and belief, Charter maintains a regular and established place of business in this District, including by maintaining or controlling retail stores and a newsroom in this District and by maintaining and operating optical communications networks in this District, including on cellular towers and other installation sites owned or leased by Charter. Also, Charter is engaged in activities including: transacting business in this district and purposefully directing its business activities, including the installation, maintenance, and use of infringing communications networks, services, and other technologies in this District, and the sale or offer for sale of services and goods to this District to aid, abet, or contribute to the infringement of third parties in this District.

THE ASSERTED PATENTS

18. On September 5, 2000, the USPTO duly and legally issued U.S. Patent No. 6,115,174 (“the ’174 Patent”), entitled “Optical Signal Varying Devices.” A copy of the ’174 Patent is attached hereto as Exhibit 1.

19. Optic153 owns all substantial right, title, and interest in the ’174 Patent, and holds the right to sue and recover damages for infringement thereof, including past infringement.

20. On May 22, 2001, the USPTO duly and legally issued U.S. Patent No. 6,236,487 (“the ’487 Patent”), entitled “Optical Communication Control System.” A copy of the ’487 Patent is attached hereto as Exhibit 2.

21. Optic153 owns all substantial right, title, and interest in the '487 Patent, and holds the right to sue and recover damages for infringement thereof, including past infringement.

22. On Feb. 5, 2002, the USPTO duly and legally issued U.S. Patent No. 6,344,922 ("the '922 Patent"), entitled "Optical Signal Varying Devices." A copy of the '922 Patent is attached hereto as Exhibit 3.

23. Optic153 owns all substantial right, title, and interest in the '922 Patent, and holds the right to sue and recover damages for infringement thereof, including past infringement.

24. On Mar. 12, 2002, the USPTO duly and legally issued U.S. Patent No. 6,356,383 ("the '383 Patent"), entitled "Optical Transmission Systems Including Optical Amplifiers Apparatuses and Methods." A copy of the '383 Patent is attached hereto as Exhibit 4.

25. Optic153 owns all substantial right, title, and interest in the '383 Patent, and holds the right to sue and recover damages for infringement thereof, including past infringement.

26. On Jul. 1, 2003, the USPTO duly and legally issued U.S. Patent No. 6,587,261 ("the '261 Patent"), entitled "Optical Transmission Systems Including Optical Amplifiers Apparatuses and Methods of Use Therein." A copy of the '261 Patent is attached hereto as Exhibit 5.

27. Optic153 owns all substantial right, title, and interest in the '261 Patent, and holds the right to sue and recover damages for infringement thereof, including past infringement.

28. On Aug. 3, 2004, the USPTO duly and legally issued U.S. Patent No. 6,771,413 ("the '413 Patent"), entitled "Optical Transmission Systems Including Optical Amplifiers, Apparatuses and Methods." A copy of the '413 Patent is attached hereto as Exhibit 6.

29. Optic153 owns all substantial right, title, and interest in the '413 Patent, and holds the right to sue and recover damages for infringement thereof, including past infringement.

COUNT I - INFRINGEMENT OF U.S. PATENT NO. 6,115,174

30. Plaintiff incorporates and realleges the preceding paragraphs as if fully set forth herein.

31. The '174 Patent is directed to systems and methods for controlling signal variation in an optical fiber, as described and claimed in the '174 Patent.

32. Charter directly infringed at least Claim 19 of the '174 Patent, in this judicial District and elsewhere in the United States, pursuant to 35 U.S.C. § 271(a), literally or under the doctrine of equivalents, by, among other things, by making, using, selling, offering to sell, and/or importing in or into the United States, without authority: products, devices, systems, and/or components of systems that provide pump energy in a plurality of pump wavelengths to controllably produce Raman transmission in an optical fiber (“'174 Accused Instrumentalities”). The '174 Accused Instrumentalities include, for example and without limitation, Charter’s optical communications networks and systems (e.g., Charter’s fiber-optic network and fiber-to-the-premises network) that employ Raman amplification or Raman amplifiers and/or systems, including Raman optical amplifiers including associated hardware and software (e.g., Cisco Systems’s (“Cisco”) OPT-RAMP-C and OPT-RAMP-CE and EDRA-x-xx), counter-propagating and co-propagating (e.g., Cisco’s 15454-M-RAMAN-CTP card and 15454-M-RAMAN-COP card) Raman units including associated hardware and software, and/or other telecommunications networks and systems that deploy or have deployed such platforms or components.

33. By way of example, the representative instrumentality, Charter’s fiber-optic network, employs Cisco’s ONS 15454 network platform as early as 2006 and infringes the '174 Patent. *See, e.g.*, “Charter Communications Enhances Business and Residential Service Delivery With Cisco IP NGN Architecture” *available at*

<https://www.businesswire.com/news/home/20061018005208/en/Charter-Communications-Enhances-Business-Residential-Service-Delivery> (last visited Dec. 28, 2020); *see also* “The Charter Communications Opportunity for Cerent – When Competing Equipment Suppliers Don’t Execute,” *available at* <http://robkoslowsky.weebly.com/blog/the-charter-communications-opportunity-for-cerent-when-competing-equipment-suppliers-dont-execute> (last visited Dec. 28, 2020). The ONS 15454 Multiservice Transport Platform includes Raman amplifiers such as OPT-RAMP-C and OPT-RAMP-CE. An image of the OPT-RAMP-C is shown below:



See “Raman C-Band Optical Amplifier for the Cisco ONS 15454 Multiservice Transport Platform” (“**Raman C-Band Datasheet**”) at 1, *available at* https://www.cisco.com/c/en/us/products/collateral/optical-networking/ons-15454-series-multiservice-provisioning-platforms/data_sheet_c78-500925.html (last visited Apr. 1, 2020).

34. More specifically, the '174 Accused Instrumentalities, including the representative instrumentality, Charter’s fiber-optic network, perform a method of controlling signal variation in an optical fiber comprising providing an optical fiber (e.g., optical fiber(s) connected between optical nodes, optical terminal units, and optical network units) configured to produce concentrated Raman gain in a signal wavelength range. *See, e.g.*, Cisco ONS 15454 Reference Manual, Releases 9.1, 9.2, and 9.2.1, Chapter 13: Management Network Connectivity

(“**Management Network Connectivity**”) at Fig. 13-11, *available at*

https://www.cisco.com/c/en/us/td/docs/optical/15000r9_1/15454/sonet/reference/guide/454a91_reference/454a91_nwconnectivity.html (last visited Dec. 10, 2020) (showing the ONS 15454 connected in an optical network):

Figure 13-11 IP Scenario 7: ONS 15454 SOCKS Proxy Server with GNE and ENes on the Same Subnet

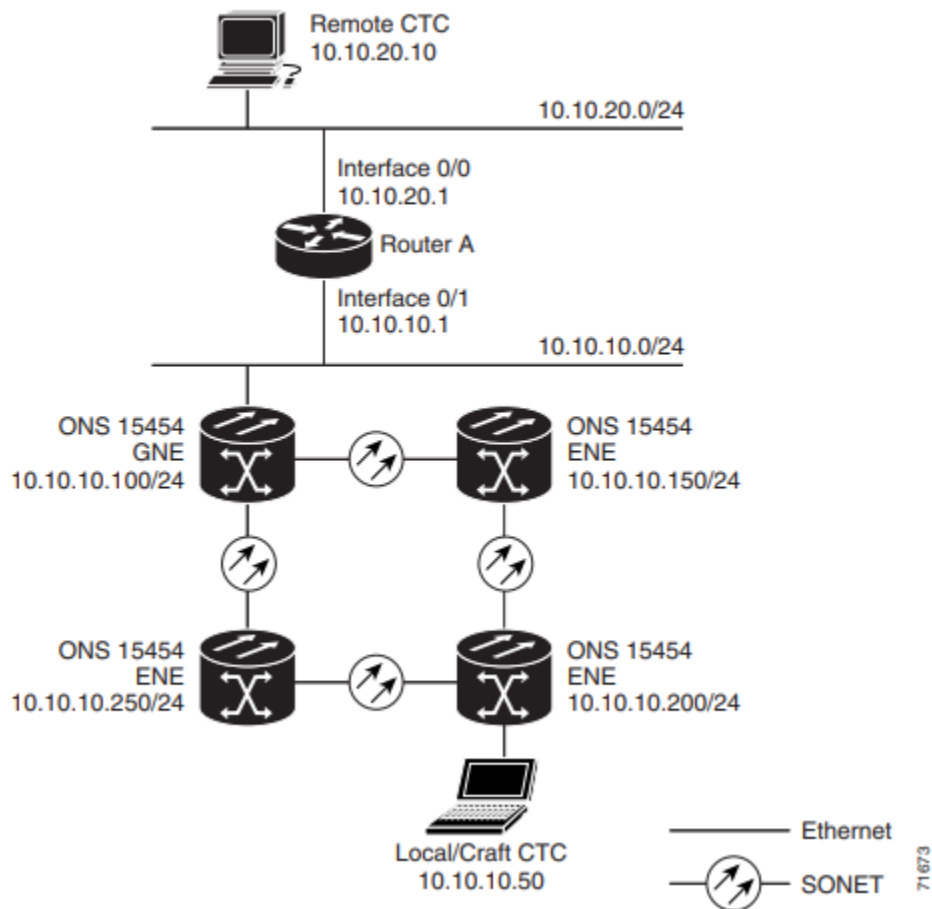

See, e.g., Cisco ONS 15454 DWDM Network Configuration Guide, Release 10.x.x, Chapter:

Network Reference (“**Network Reference**”) at Fig. 30, *available at*

https://www.cisco.com/c/en/us/td/docs/optical/15000r10_0/dwdm/network_config/guide/b_ons_network_configuration/b_ons_network_configuration_chapter_010110.html#ID832 (last visited Dec. 11, 2020) (annotated):

Figure 30. Nodes Using OPT-RAMP-C or OPT-RAMP-CE Cards

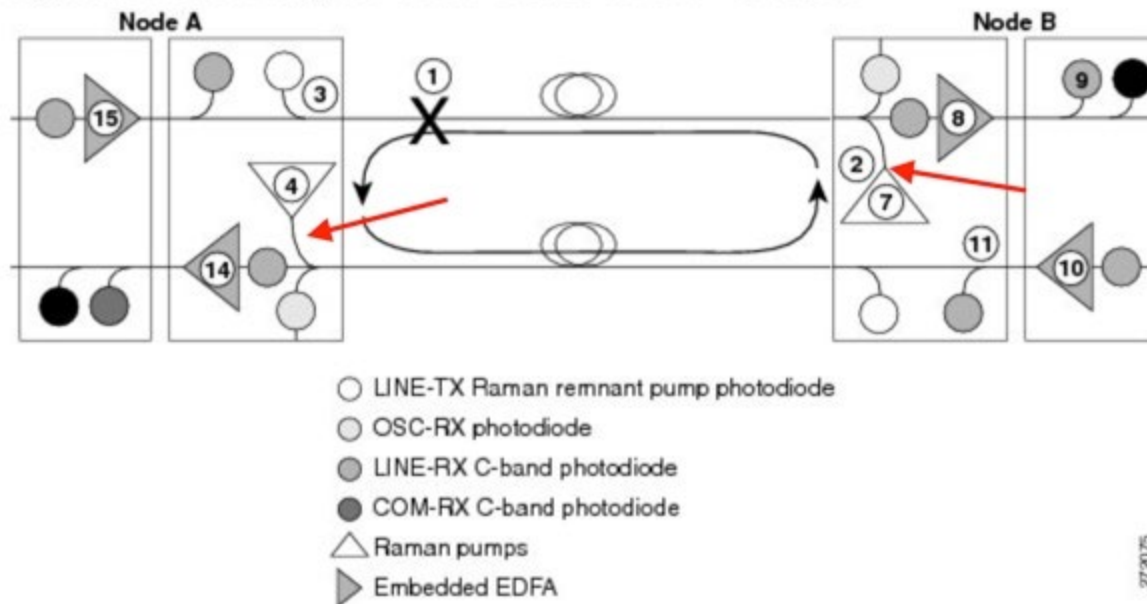

See also **Raman C-Band Datasheet** at 1 (“The Cisco[®] ONS 15454 Multiservice Transport Platform (MSTP) offers a Raman optical amplifier card (Figure 1) operating in the C-band region of the optical spectrum to extend the reach and capacity of a regional, long-haul, or ultra-long-haul optical network.”).

35. Also, the ’174 Accused Instrumentalities, including the representative instrumentality, Charter’s fiber-optic network, couple a pump source (e.g., two pump lasers) to the fiber to provide pump energy in a plurality of pump wavelengths (e.g., 1425 nm and 1452 nm) having sufficient pump energy to produce Raman gain and a signal variation profile in the signal wavelength range (e.g., 1529.0 nm to 1562.5 nm) and to controllably produce amplification, attenuation and lossless transmission in the optical fiber. See, e.g., **Raman C-Band Datasheet** at 1 (“The OPT-RAMP-C features an embedded low-noise EDFA gain block for C-band optical amplification and optimized system performances with Raman amplification. The Raman pumps embedded in the unit use on the latest laser technology, enabling up to 500 milliwatts (mW) of power combining just two pump lasers, thus obtaining very high efficiency

and low power consumption (Figure 2). ... A dedicated software application has been incorporated in Cisco Transport Controller to allow a fully automatic and simple configuration and tuning of the optical Raman amplifiers along a DWDM link. This software application, called Raman Tuning Wizard, can take advantage of tunable Transponder or Muxponder units to evaluate the physical characteristics of the span's fiber, determine the optimal mix of Raman pump wavelengths, and define the contribution of Raman versus EDFA for the overall optical amplification of the unit.”); *see also id.* at Fig. 2:

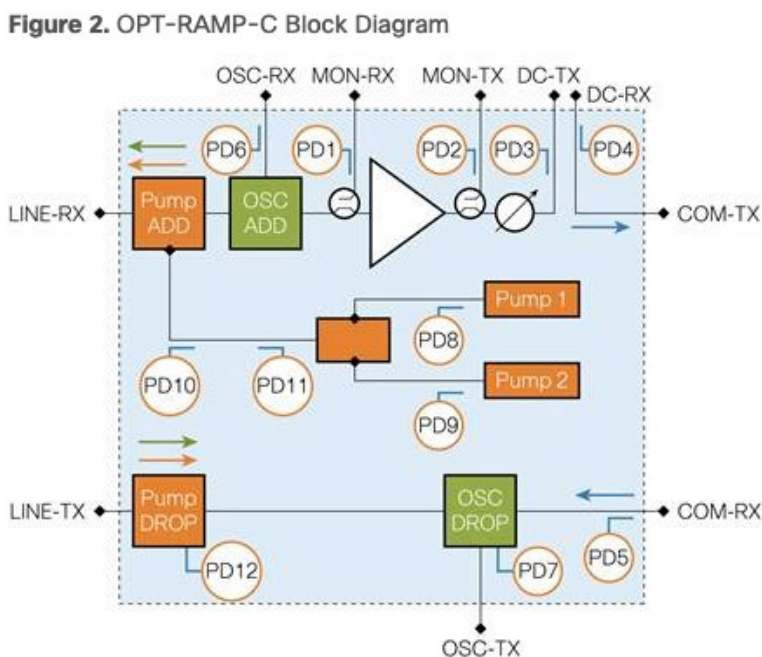

36. Further, the '174 Accused Instrumentalities, including the representative instrumentality, Charter's fiber-optic network, control the pump energy provided in at least one of said pump wavelengths to vary the signal variation profile (e.g., from 8.5dB to 13.5dB) over the signal wavelength range (e.g., 1529.0 nm to 1562.5 nm) in the optical fiber and produce amplification, attenuation and lossless transmission in the optical fiber. *See, e.g., Raman C-Band Datasheet* at 1 (“The OPT-RAMP-C also provides an embedded fast Gain Control for transient suppression to respond quickly to network changes without impairments and

degradation of existing wavelengths. In addition to this, the unit features an embedded Gain Flattening Filter (GFF) for the compensation of the ripple generated by the cascaded Raman and EDFA stages. The amplifier integrates a software-controllable variable optical attenuator (VOA) to provide gain tilt control capabilities and to optimize and control the per-channel power at the input of the mid-access loss for dispersion compensation units (DCUs). ... A dedicated software application has been incorporated in Cisco Transport Controller to allow a fully automatic and simple configuration and tuning of the optical Raman amplifiers along a DWDM link. This software application, called Raman Tuning Wizard, can take advantage of tunable Transponder or Muxponder units to evaluate the physical characteristics of the span's fiber, determine the optimal mix of Raman pump wavelengths, and define the contribution of Raman versus EDFA for the overall optical amplification of the unit.”).

37. Discovery is expected to uncover the full extent of Charter's unlawful use of Optic153's patented technology in the '174 Patent beyond the '174 Accused Instrumentalities already identified through public information.

38. On information and belief, Charter also directly infringed at least Claim 19 of the '174 Patent by testing the '174 Accused Instrumentalities, including in relation to network testing and improvement responsive to user/customer feedback, and demonstration at trade shows, sales facilities, customer sites, and training/tutorial videos.

39. Plaintiff has suffered damages as a result of Charter's infringement of the '174 Patent.

40. Plaintiff reserves the right to modify its infringement theories as discovery progresses in this case. Plaintiff shall not be estopped for purposes of its infringement contentions or its claim constructions by the foregoing discussions on how the '174 Accused

Instrumentalities infringe the '174 Patent. Plaintiff intends only that the foregoing discussions satisfy the notice requirements of Rule 8(a)(2) of the Federal Rule of Civil Procedure, and that they should not be construed as Plaintiff's preliminary or final infringement contentions or preliminary or final claim construction positions.

COUNT II - INFRINGEMENT OF U.S. PATENT NO. 6,236,487

41. Plaintiff incorporates and realleges the preceding paragraphs as if fully set forth herein.

42. The '487 Patent is directed to systems and methods for controlling an optical transmission system, as described and claimed in the '487 Patent.

43. Charter directly infringed at least Claims 26-28 of the '487 Patent, in this judicial District and elsewhere in the United States, pursuant to 35 U.S.C. § 271(a), literally or under the doctrine of equivalents, by, among other things, by making, using, selling, offering to sell, and/or importing in or into the United States, without authority: products, devices, systems, and/or components of systems that control a concentrated optical amplifier to vary an optical signal to have at least one desired signal characteristics when the optical signal reaches an optical processing node ("'487 Accused Instrumentalities"). The '487 Accused Instrumentalities include, for example and without limitation, Charter optical communications networks and systems (e.g., Charter's fiber-optic network) that employ Cisco's ONS 15454 Series platform including associated hardware and software, and/or other telecommunications networks and systems that deploy or have deployed such platforms or components.

44. By way of example, the representative instrumentality, Charter's fiber-optic network, employs Cisco's ONS 15454 network platform and infringes the '487 Patent. *See, e.g.*, "Charter Communications Enhances Business and Residential Service Delivery With Cisco IP

NGN Architecture” *available at*

<https://www.businesswire.com/news/home/20061018005208/en/Charter-Communications-Enhances-Business-Residential-Service-Delivery> (last visited Dec. 28, 2020); *see also* “The Charter Communications Opportunity for Cerent – When Competing Equipment Suppliers Don’t Execute,” *available at* <http://robkoslowsky.weebly.com/blog/the-charter-communications-opportunity-for-cerent-when-competing-equipment-suppliers-dont-execute> (last visited Dec. 28, 2020). The ONS 15454 Multiservice Transport Platform includes erbium doped fiber amplifiers (e.g., OPT-PRE Amplifier Card, OPT-BST-L Amplifier Card and OPT-AMP-L Card) and Raman amplifiers (e.g., OPT-RAMP-C and OPT-RAMP-CE Cards). *See, e.g.*, Cisco ONS 15454 DWDM Configuration Guide, Release 9.6.x, Chapter 5, Optical Amplifier Cards (“**Optical Amplifier Cards**”) *available at* https://www.cisco.com/c/en/us/td/docs/optical/15000r9_6/dwdm/configuration/guide/454d96_configuration/454d96_optamp.html (last visited Dec. 10, 2020).

45. More specifically, the ’487 Accused Instrumentalities, including the representative instrumentality, Charter’s fiber-optic network, perform a method of controlling an optical transmission system comprising positioning at least one signal varying device including a concentrated optical amplifier (e.g., EDFA or Raman amplifiers) remote from an optical processing node to vary an optical signal passing to the optical processing node. *See, e.g.*, **Management Network Connectivity** at Fig. 13-11:

Figure 13-11 IP Scenario 7: ONS 15454 SOCKS Proxy Server with GNE and ENes on the Same Subnet

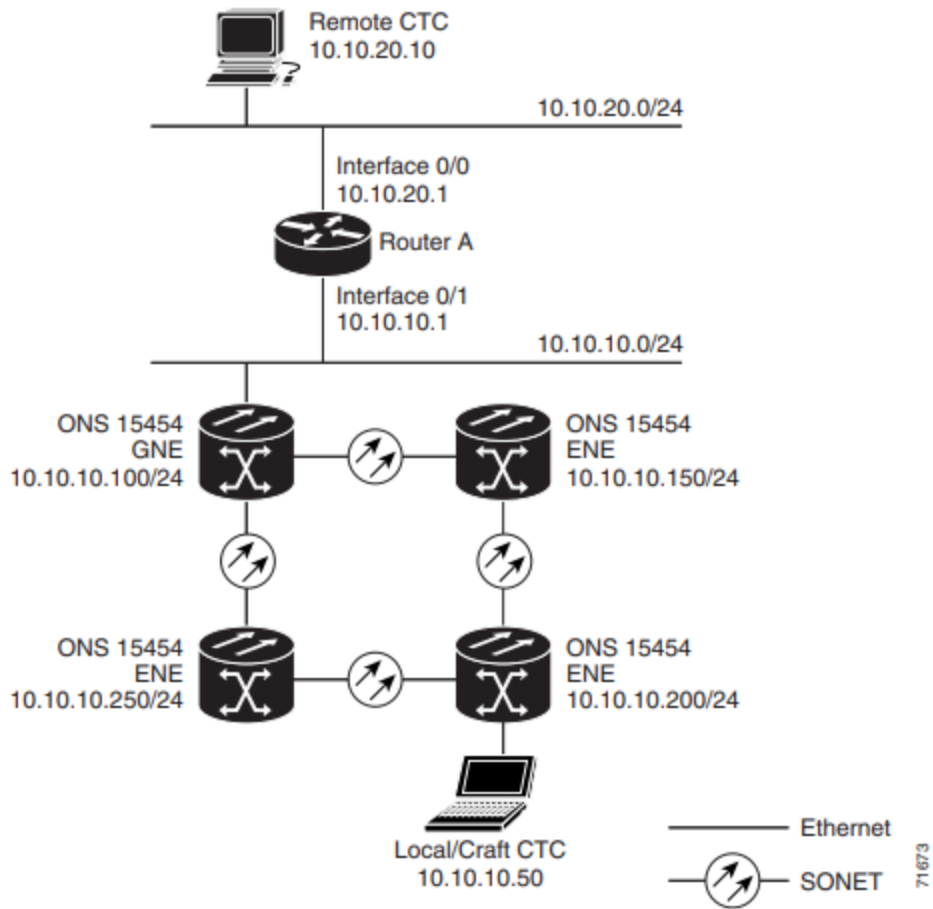

See, e.g., **Network Reference** at Fig. 30 (annotated):

Figure 30. Nodes Using OPT-RAMP-C or OPT-RAMP-CE Cards

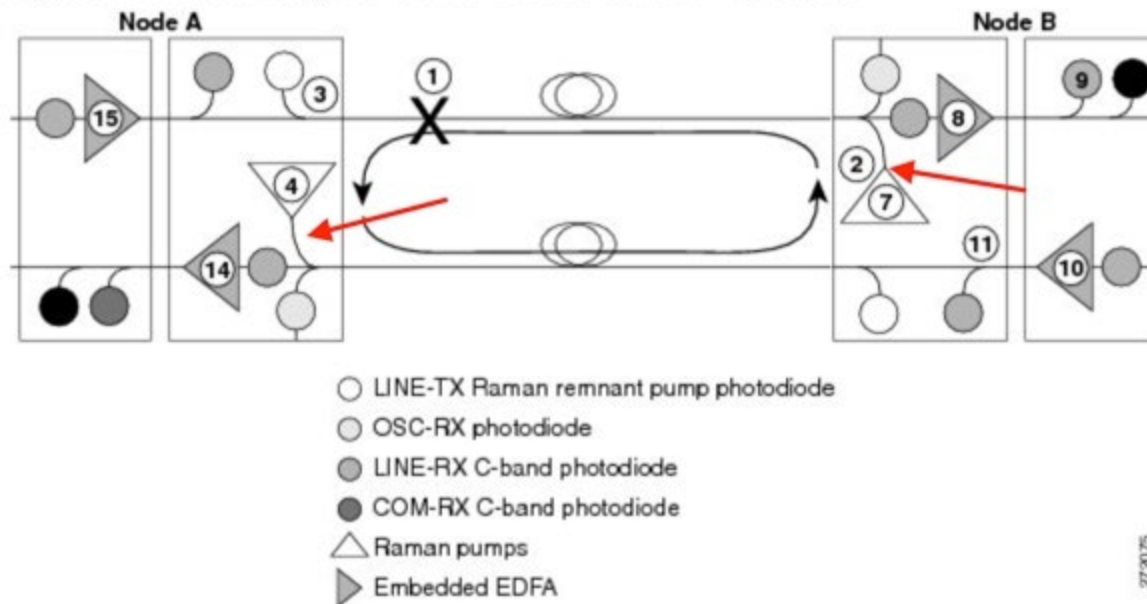

See also **Raman C-Band Datasheet** at 1 (“The Cisco® ONS 15454 Multiservice Transport Platform (MSTP) offers a Raman optical amplifier card (Figure 1) operating in the C-band region of the optical spectrum to extend the reach and capacity of a regional, long-haul, or ultra-long-haul optical network.”).

46. Also, the '487 Accused Instrumentalities, including the representative instrumentality, Charter’s fiber-optic network, control the at least one concentrated optical amplifier to vary the optical signal to have at least one desired signal characteristic when the optical signal reaches the optical processing node. See Cisco ONS 15454 DWDM Reference Manual, Release 8.5.x, Chapter 10, Network Reference (“**DWDM Reference Manual**”) at 1, available at https://www.cisco.com/c/en/us/td/docs/optical/15000r8_5/dwdm/reference/guide/d85refr/d85ntrf.html (last visited Dec. 11, 2020) (“The per-channel power and working mode (gain or power) are set by automatic node setup (ANS). The provisioning is conducted on a per-side basis. A preamplifier or a booster amplifier facing Side *i* is provisioned using the Side *i* parameters

present in the node database, where i - A, B, C, D, E, F, G, or H. Starting from the expected per-channel power, the amplifiers automatically calculate the gain setpoint after the first channel is provisioned. An amplifier gain setpoint is calculated in order to make it equal to the loss of the span preceding the amplifier itself. After the gain is calculated, the setpoint is no longer changed by the amplifier. Amplifier gain is recalculated every time the number of provisioned channels returns to zero. If you need to force a recalculation of the gain, move the number of channels back to zero.”) *See also id.* at 1 (“APC algorithms manage the optical parameters of the OPT-BST, OPT-PRE, OPT-AMP-17-C, 32DMX, 40-DMX-C, 40-DMX-CE, OPT-BST-L, OPT-AMP-L, OPT-AMP-C, and 32DMX-L cards.”) Further, the ’487 Accused Instrumentalities, including the representative instrumentality, Charter’s fiber-optic network, also detect characteristics of the optical signal and compare detected characteristics of the optical signal to the at least one desired characteristic, wherein controlling includes controlling the at least one signal varying device to vary the optical signal until the detected characteristics correspond to the desired characteristics (e.g., target power) when the optical signal arrives at the processing nodes. *See, e.g., DWDM Reference Manual* at 1 (“Amplifier software uses a control gain loop with fast transient suppression to keep the channel power constant regardless of any changes in the number of channels. Amplifiers monitor the changes to the input power and change the output power proportionately according to the calculated gain setpoint. The shelf controller software emulates the control output power loop to adjust for fiber degradation. To perform this function, the TCC2/TCC2P needs to know the channel distribution, which is provided by a signaling protocol, and the expected per-channel power, which you can provision. The TCC2/TCC2P compares the actual amplifier output power with the expected amplifier output power and modifies the setpoints if any discrepancies occur. ”); *see also id.* at 11 (“In constant

gain mode, the amplifier power out control loop performs the following input and output power calculations, where G represents the gain and t represents time.

$$P_{out}(t) = G * P_{in}(t) \text{ (mW)}$$

$$P_{out}(t) = G + P_{in}(t) \text{ (dB)}$$

In a power-equalized optical system, the total input power is proportional to the number of channels. The amplifier software compensates for any variation of the input power due to changes in the number of channels carried by the incoming signal.”).

47. On information and belief, the '487 Accused Instrumentalities, including the representative instrumentality, Charter's fiber-optic network, also select the at least one desired signal characteristic from the group consisting of signal-to-noise ratio, signal intensity, noise intensity, and combinations thereof. *See, e.g., DWDM Reference Manual*, at 1 (“APC corrects the power level only if the variation exceeds the hysteresis thresholds of +/- 0.5 dB. Any power level fluctuation within the threshold range is skipped since it is considered negligible. Because APC is designed to follow slow time events, it skips corrections greater than 3 dB. This is the typical total aging margin that is provisioned during the network design phase. After you provision the first channel or the amplifiers are turned up for the first time, APC does not apply the 3 dB rule. In this case, APC corrects all the power differences to turn up the node.”).

48. Discovery is expected to uncover the full extent of Charter's unlawful use of Optic153's patented technology in the '487 Patent beyond the '487 Accused Instrumentalities already identified through public information.

49. On information and belief, Charter also directly infringed at least Claims 26-28 of the '487 Patent by testing the '487 Accused Instrumentalities, including in relation to network

testing and improvement responsive to user/customer feedback, and demonstration at trade shows, sales facilities, customer sites, and training/tutorial videos.

50. Plaintiff has suffered damages as a result of Charter's infringement of the '487 Patent.

51. Plaintiff reserves the right to modify its infringement theories as discovery progresses in this case. Plaintiff shall not be estopped for purposes of its infringement contentions or its claim constructions by the foregoing discussions on how the '487 Accused Instrumentalities infringe the '487 Patent. Plaintiff intends only that the foregoing discussions satisfy the notice requirements of Rule 8(a)(2) of the Federal Rule of Civil Procedure, and that they should not be construed as Plaintiff's preliminary or final infringement contentions or preliminary or final claim construction positions.

COUNT III - INFRINGEMENT OF U.S. PATENT NO. 6,344,922

52. Plaintiff incorporates and realleges the preceding paragraphs as if fully set forth herein.

53. The '922 Patent is directed to systems and methods for controlling signal variation in an optical fiber, as described and claimed in the '922 Patent.

54. Charter directly infringed at least Claim 32 of the '922 Patent, in this judicial District and elsewhere in the United States, pursuant to 35 U.S.C. § 271(a), literally or under the doctrine of equivalents, by, among other things, by making, using, selling, offering to sell, and/or importing in or into the United States, without authority: products, devices, systems, and/or components of systems that provide two pump sources with at least one being controlled to vary a signal variation profile and Raman gain ("'922 Accused Instrumentalities"). The '922 Accused Instrumentalities include, for example and without limitation, Raman C-Band optical amplifiers

including associated hardware and software (e.g., OPT-RAMP-C and OPT-RAMP-CE), counter-propagating (e.g., 15454-M-RAMAN-CTP card) and co-propagating (e.g., 15454-M-RAMAN-COP card) Raman units including associated hardware and software, Raman platforms and systems including associated hardware and software (e.g., Cisco ONS 15454 Multiservice Transport Platform), and/or telecommunications networks and systems (e.g., Charter's fiber-optic network) that employ such platforms or components.

55. By way of example, the representative instrumentality, Charter's fiber-optic network, employs Cisco's ONS 15454 Multiservice Transport Platform and infringes the '922 Patent. *See, e.g.*, "Charter Communications Enhances Business and Residential Service Delivery With Cisco IP NGN Architecture" *available at* <https://www.businesswire.com/news/home/20061018005208/en/Charter-Communications-Enhances-Business-Residential-Service-Delivery> (last visited Dec. 28, 2020); *see also* "The Charter Communications Opportunity for Cerent – When Competing Equipment Suppliers Don't Execute," *available at* <http://robkoslowsky.weebly.com/blog/the-charter-communications-opportunity-for-cerent-when-competing-equipment-suppliers-dont-execute> (last visited Dec. 28, 2020). The ONS 15454 Multiservice Transport Platform includes Raman amplifiers such as OPT-RAMP-C, OPT-RAMP-CE, and EDRA-1 and EDRA-2.

56. More specifically, the '922 Accused Instrumentalities, including the representative instrumentality, Charter's fiber-optic network, provide a computerized method of controlling signal variation in an optical fiber comprising providing an optical fiber suitable for transmitting optical signals (e.g., optical fiber(s) connected between optical nodes, optical terminal units, and optical network units) in at least one signal wavelength range (e.g., 1529.0

nm to 1562.5 nm) and facilitating Raman gain in the at least one signal wavelength range. See, e.g., **Management Network Connectivity** at Fig. 13-11:

Figure 13-11 IP Scenario 7: ONS 15454 SOCKS Proxy Server with GNE and ENes on the Same Subnet

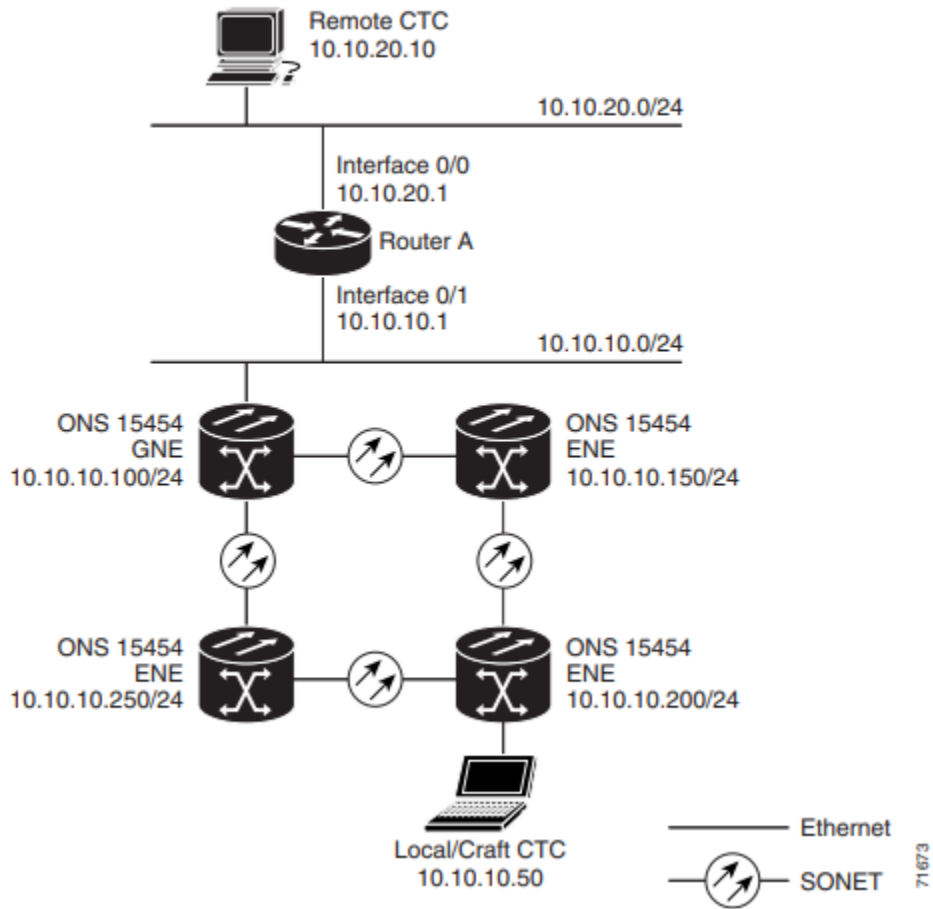

See, e.g., **Network Reference** at Fig. 30 (annotated):

Figure 30. Nodes Using OPT-RAMP-C or OPT-RAMP-CE Cards

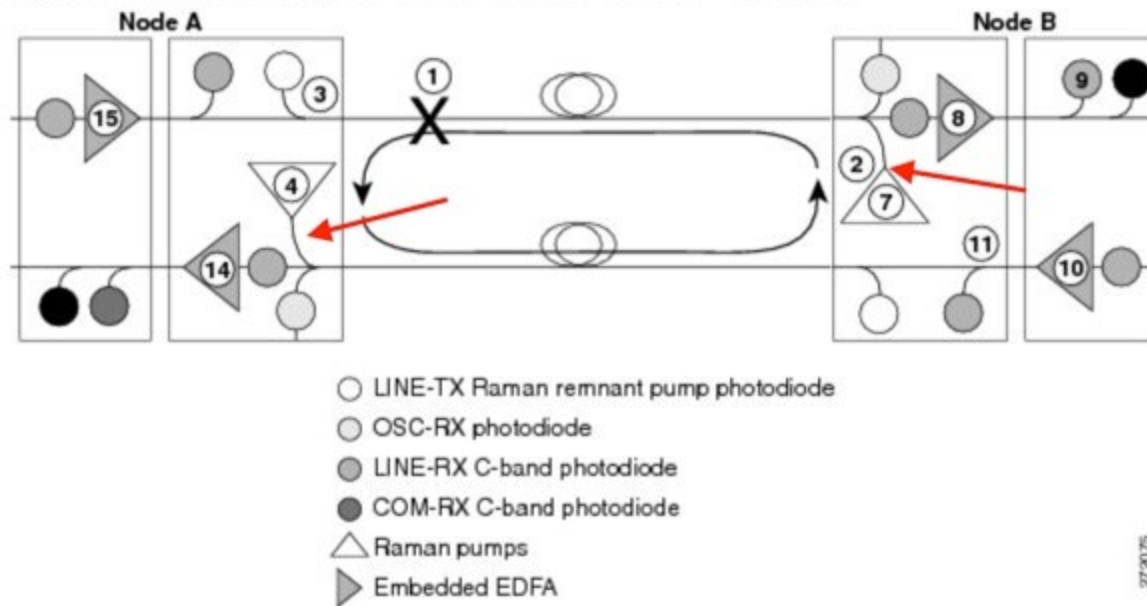

See also **Raman C-Band Datasheet** at 1 (“The Cisco® ONS 15454 Multiservice Transport Platform (MSTP) offers a Raman optical amplifier card (Figure 1) operating in the C-band region of the optical spectrum to extend the reach and capacity of a regional, long-haul, or ultra-long-haul optical network.”); see also Cisco ONS 15454 DWDM Network Configuration Guide, Release 10.x.x, Chapter: Node Reference (“**Node Reference**”) at Fig. 109, available at https://www.cisco.com/c/en/us/td/docs/optical/15000r10_0/dwdm/network_config/guide/b_ons_network_configuration/b_ons_network_configuration_chapter_01101.html (last visited Dec. 11, 2020):

Figure 109. Raman Gain on Node B

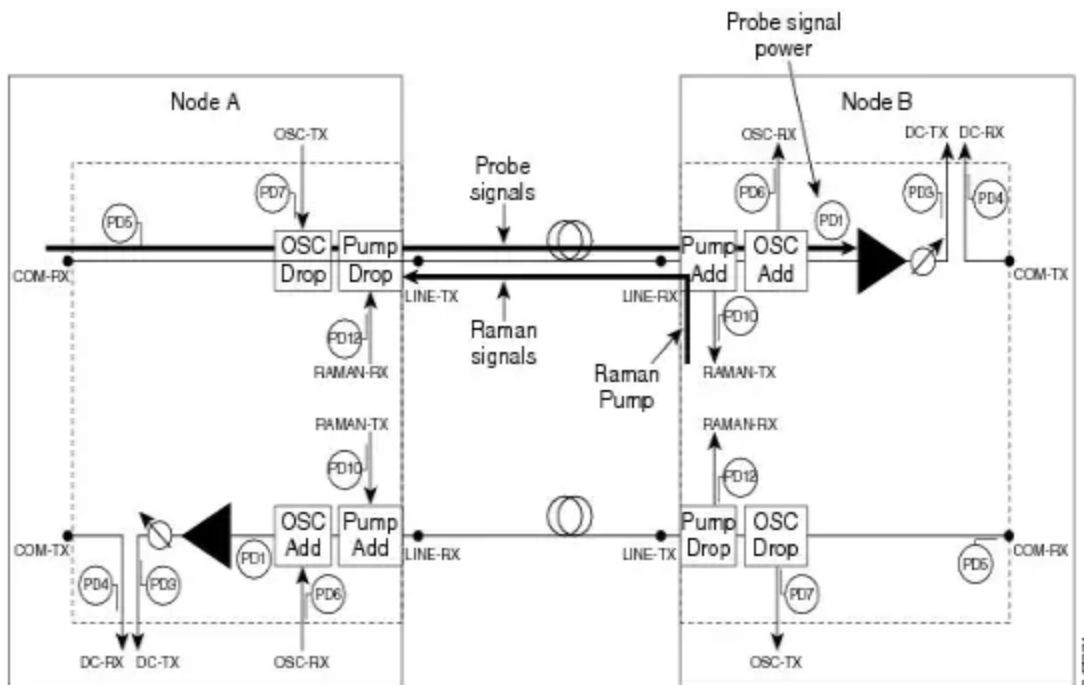

The S1low, S1high, S2low, and S2low values in the Maintenance > Installation tab are based on the power values read on the LINE-RX port of Node B.

57. Also, the '922 Accused Instrumentalities, including the representative instrumentality, Charter's fiber-optic network, couple a first pump source (e.g., any one or combination of P1/PD11, P2/PD12, P3/PD13, and P4/PD14) to the fiber to provide pump energy in a first set of Raman wavelengths including a plurality of pump wavelengths (e.g., any one or combination of λ_{P1} , λ_{P2} , λ_{P3} , and λ_{P4}) having sufficient pump energy to produce Raman gain in the optical signal according to a signal variation profile in the signal wavelength range and a second pump source (e.g., any one or combination of P1/PD11, P2/PD12, P3/PD13, and P4/PD14) configured to provide pump energy in at least a second set of Raman wavelengths (e.g., any one or combination of λ_{P1} , λ_{P2} , λ_{P3} , and λ_{P4}) to provide Raman gain in the first set of Raman wavelengths in said optical fiber. *See, e.g., Raman C-Band Datasheet at 1* (describing the Raman pump power operating range of the OPT-RAMP-C as 100 mW to 450 mW); *see also*

Node Reference at 1 (“The Raman pump is equipped with two different Raman pumps transmitting powers (P1 and P2) at two different wavelengths Lambda1 and Lambda2. During installation, the two pumps alternatively turn ON and OFF at two different power values. Lambda1 and Lambda2 signals are used as probes at the end of spans to measure Raman gain efficiency of the two Raman pumps separately.”); *see also id.* at Table 12:

Table 12. Example of Raman Power Measurements

Input	P1	P2	Probe Signal Power Received at Node B
Lambda1=1530.33 nm at Node A	P _{low} = 100 mW	P _{min} = 8 mW	S1 _{low}
	P _{high} = 250 mW	P _{min} = 8 mW	S1 _{high}
Lambda2=1560.61 nm at Node A	P _{min} = 8 mW	P _{low} = 100 mW	S2 _{low}
	P _{min} = 8 mW	P _{high} = 250 mW	S2 _{low}

58. Further, the '922 Accused Instrumentalities, including the representative instrumentality, Charter's fiber-optic network, monitor characteristics of the optical signals in a signal wavelength range passing through the optical fiber and controls the pump energy supplied by the at least one of the first and second pump sources in at least one of the pump wavelengths to vary the signal variation profile (e.g., from 8.5dB to 13.5dB) and Raman gain to provide Raman amplification, attenuation, and lossless transmission over the signal wavelength range in the optical fiber. *See, e.g., Network Reference* at 1 (“Amplifier software uses a control gain loop with fast transient suppression to keep the channel power constant regardless of any changes in the number of channels. Amplifiers monitor the changes to the input power and change the output power proportionately according to the calculated gain setpoint. The shelf controller software emulates the control output power loop to adjust for fiber degradation. To

perform this function, the controller card needs to know the channel distribution, which is provided by a signaling protocol, and the expected per channel power, which you can provision. The controller card compares the actual amplifier output power with the expected amplifier output power and modifies the setpoints if any discrepancies occur.”); *see also* **Raman C-Band Datasheet at 1** (“The OPT-RAMP-C also provides an embedded fast Gain Control for transient suppression to respond quickly to network changes without impairments and degradation of existing wavelengths. In addition to this, the unit features an embedded Gain Flattening Filter (GFF) for the compensation of the ripple generated by the cascaded Raman and EDFA stages. The amplifier integrates a software-controllable variable optical attenuator (VOA) to provide gain tilt control capabilities and to optimize and control the per-channel power at the input of the mid-access loss for dispersion compensation units (DCUs). ... A dedicated software application has been incorporated in Cisco Transport Controller to allow a fully automatic and simple configuration and tuning of the optical Raman amplifiers along a DWDM link. This software application, called Raman Tuning Wizard, can take advantage of tunable Transponder or Muxponder units to evaluate the physical characteristics of the span’s fiber, determine the optimal mix of Raman pump wavelengths, and define the contribution of Raman versus EDFA for the overall optical amplification of the unit.”); *see also* **Node Reference at 1** (“Automatic Raman Pump Calculation The Raman gain depends on the characteristics of the span (fiber type and span loss). To obtain optimum Raman gain, a correct mix of pump powers must be provisioned. Tuning of the four Raman pumps is crucial before traffic is provisioned. The tuning procedure is called Automatic Raman Power Calculation (ARPC). This procedure assesses the Raman gain on a C-band signal using pre-defined Raman pump values. ARPC applies to the RAMAN-CTP and EDRA cards.”).

59. Discovery is expected to uncover the full extent of Charter's unlawful use of Optic153's patented technology in the '922 Patent beyond the '922 Accused Instrumentalities already identified through public information.

60. On information and belief, Charter also directly infringed at least Claim 32 of the '922 Patent by testing the '922 Accused Instrumentalities, including in relation to network testing and improvement responsive to user/customer feedback, and demonstration at trade shows, sales facilities, customer sites, and training/tutorial videos.

61. Plaintiff has suffered damages as a result of Charter's infringement of the '922 Patent.

62. Plaintiff reserves the right to modify its infringement theories as discovery progresses in this case. Plaintiff shall not be estopped for purposes of its infringement contentions or its claim constructions by the foregoing discussions on how the '922 Accused Instrumentalities infringe the '922 Patent. Plaintiff intends only that the foregoing discussions satisfy the notice requirements of Rule 8(a)(2) of the Federal Rule of Civil Procedure, and that they should not be construed as Plaintiff's preliminary or final infringement contentions or preliminary or final claim construction positions.

COUNT IV - INFRINGEMENT OF U.S. PATENT NO. 6,356,383

63. Plaintiff incorporates and realleges the preceding paragraphs as if fully set forth herein.

64. The '383 Patent is directed to systems and methods for amplifying optical signals, as described and claimed in the '383 Patent.

65. Charter directly infringed at least Claims 1-2 of the '383 Patent, in this judicial District and elsewhere in the United States, pursuant to 35 U.S.C. § 271(a), literally or under the

doctrine of equivalents, by, among other things, by making, using, selling, offering to sell, and/or importing in or into the United States, without authority: products, devices, systems, and/or components of systems that counter-propagate and co-propagate optical energy to produce a desired Raman amplification (“’383 Accused Instrumentalities”). The ’383 Accused Instrumentalities include, for example and without limitation, Charter’s optical communications networks and systems (e.g., Charter’s fiber-optic network) that employ counter-propagating (e.g., Cisco Systems’ 15454-M-RAMAN-CTP card) and co-propagating (e.g., 15454-M-RAMAN-COP card) Raman units including associated hardware and software, ONS 15454 Series platform including associated hardware and software, and/or other telecommunications networks and systems that deploy or have deployed such platforms or components.

66. By way of example, the representative instrumentality, Charter’s fiber-optic network, employs Cisco’s ONS 15454 network platform and infringes the ’383 Patent. *See, e.g.*, “Charter Communications Enhances Business and Residential Service Delivery With Cisco IP NGN Architecture” *available at* <https://www.businesswire.com/news/home/20061018005208/en/Charter-Communications-Enhances-Business-Residential-Service-Delivery> (last visited Dec. 28, 2020); *see also* “The Charter Communications Opportunity for Cerent – When Competing Equipment Suppliers Don’t Execute,” *available at* <http://robkoslowsky.weebly.com/blog/the-charter-communications-opportunity-for-cerent-when-competing-equipment-suppliers-dont-execute> (last visited Dec. 28, 2020). The ONS 15454 Multiservice Transport Platform includes Raman amplifiers such as RAMAN-CTP, RAMAN-COP, 15454-M-RAMAN-CTP card, and 15454-M-RAMAN-COP card to amplify optical signals and to provide signal co-propagation and counter-propagation. An image of the RAMAN-CTP and RAMAN-COP is shown below:

Figure 5-22 shows the RAMAN-CTP card faceplate.

Figure 5-22 RAMAN-CTP Faceplate

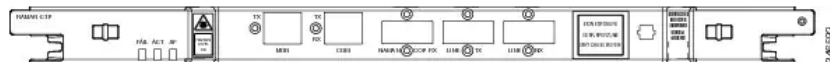

The RAMAN-COP card has only one optical port located on the faceplate. RAMAN-TX is the Raman co-propagating output port.

Figure 5-23 shows the RAMAN-COP card faceplate.

Figure 5-23 RAMAN-COP Faceplate



See “Cisco ONS 15454 DWDM Configuration Guide, Release 9.6.x, Chapter: Chapter 5, Optical Amplifier Cards” (“**Release 9.6 Optical Amplifier Cards**”), at 1, available at https://www.cisco.com/c/en/us/td/docs/optical/15000r9_6/dwdm/configuration/guide/454d96_configuration/454d96_optamp.html (last visited Dec. 11, 2020). An image of the 15454-M-RAMAN-CTP card and 15454-M-RAMAN-COP is also shown below:



See, e.g., “High Power Counter-Propagating and Co-Propagating Raman units for the Cisco ONS 15454 Multiservice Transport Platform (MSTP)” (“**15454 MSTP Datasheet**”) at 1, available at

https://www.cisco.com/c/en/us/products/collateral/optical-networking/ons-15454-series-multiservice-provisioning-platforms/data_sheet_c78-658538.html (last visited Dec. 11, 2020).

67. More specifically, the '383 Accused Instrumentalities, including the representative instrumentality, Charter's fiber-optic network, perform a method of amplifying optical signals comprising transmitting optical signals in a transmission media (e.g., optical fiber(s) connected between optical nodes, optical terminal units, and optical network units) configured to transmit and provide Raman amplification of the optical signals. *See, e.g., Management Network Connectivity* at Fig. 13-11:

Figure 13-11 IP Scenario 7: ONS 15454 SOCKS Proxy Server with GNE and ENEs on the Same Subnet

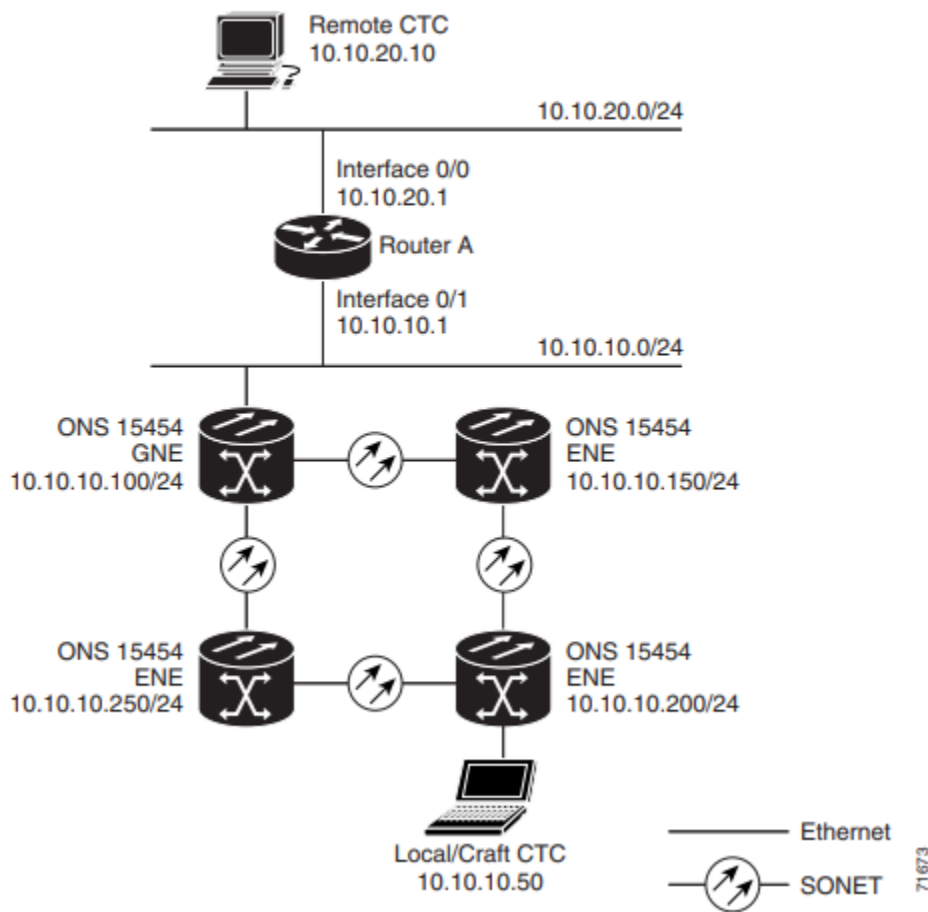

See, e.g., **Network Reference** at Fig. 30 (annotated):

Figure 30. Nodes Using OPT-RAMP-C or OPT-RAMP-CE Cards

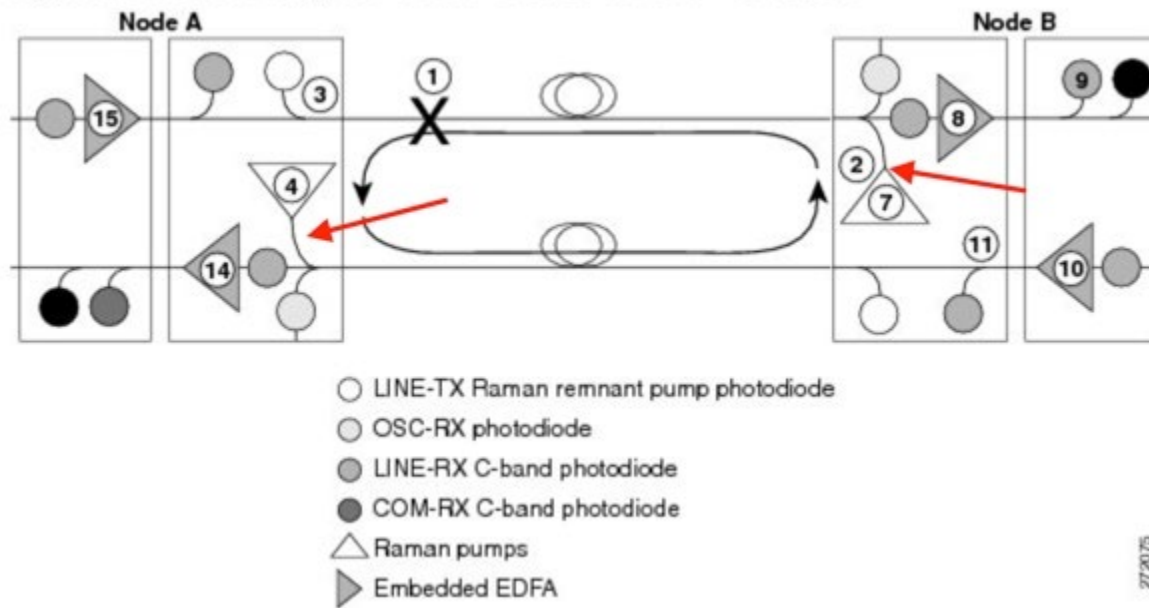

See also **Raman C-Band Datasheet** at 1 (“The Cisco® ONS 15454 Multiservice Transport Platform (MSTP) offers a Raman optical amplifier card (Figure 1) operating in the C-band region of the optical spectrum to extend the reach and capacity of a regional, long-haul, or ultra-long-haul optical network.”); see also **Node Reference** at Fig. 109:

Figure 109. Raman Gain on Node B

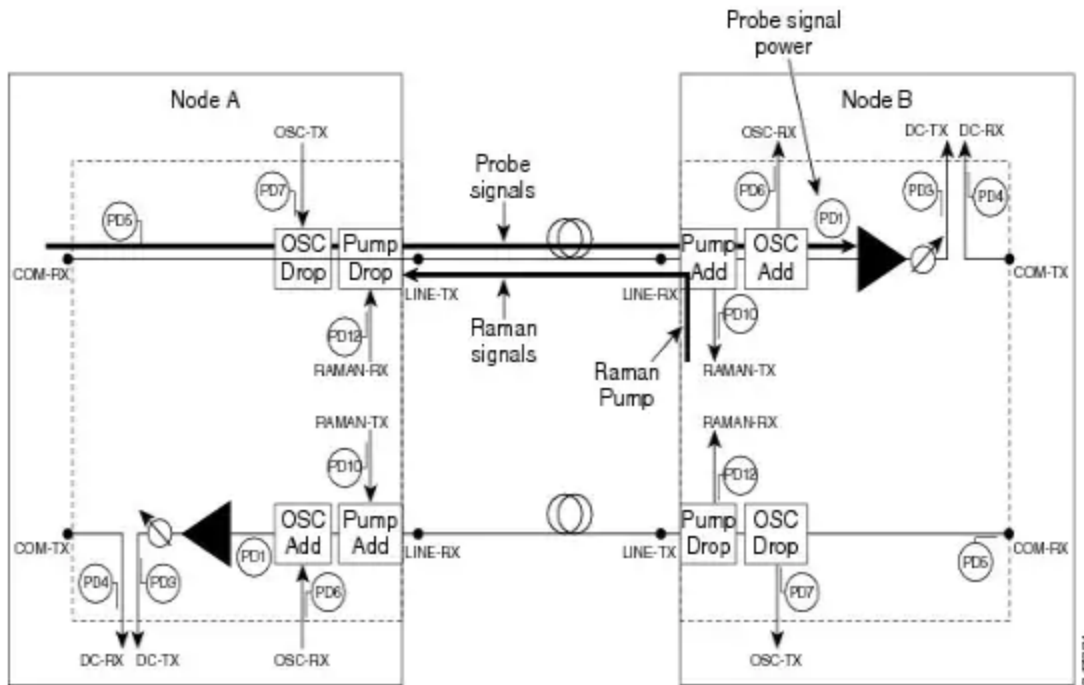

The S1low, S1high, S2low, and S2low values in the Maintenance > Installation tab are based on the power values read on the LINE-RX port of Node B.

See also **15454 MSTP Datasheet** at 1 (“The high power counter-propagating unit injects counter-propagating optical power to generate a Raman effect in the span fiber and thus amplifies the signals propagating in the same fiber. Similarly, the co-propagating Raman unit injects co-propagating optical power that also amplifies the signal through a Raman effect in fiber. The signal thus receives amplification from the optical power injected by both these units present on opposite ends of the span”); see also *id.* at Fig. 5 (annotated):

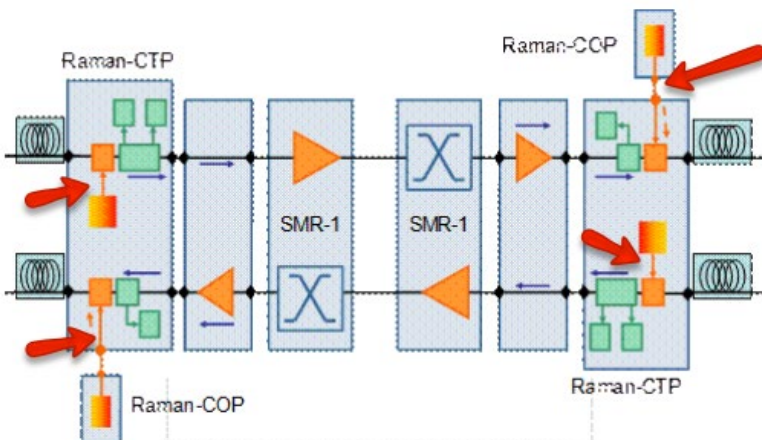
Figure 5. Equalization Stage with Single-Module ROADM 1 (SMR-1) and Counter-and Co-Propagating Raman Amplifiers

68. Also, the '383 Accused Instrumentalities, including the representative instrumentality, Charter's fiber-optic network, counter-propagate optical energy in the transmission media in a first pump wavelength range (e.g., 1428 nm to 1457 nm or $\zeta P1$ and $\zeta P2$ via Pumps 1-4) to produce Raman amplification of the optical signals, wherein the Raman amplification has a corresponding noise figure profile over an optical signal wavelength range (e.g., 1500 to 1567 nm); and, co-propagate optical energy with the optical signals in a second pump wavelength range (e.g., 1428 nm to 1457 nm or $\lambda P1$ and $\lambda P2$ via Pumps 1-4) to vary the noise figure profile of the Raman amplification produced by said counter-propagating optical energy over at least a portion of the optical signal wavelength range. wherein said co-propagating includes co-propagating optical energy in the second pump wavelength range that overlaps with shorter wavelengths in the first wavelength range (e.g., 1428 nm). *See, e.g., 15454 MSTP Datasheet at Figs. 2-3:*

Figure 2. Functional Block Diagram for the Cisco ONS 15454 MSTP High-Power Counter-Propagating Raman Amplifier

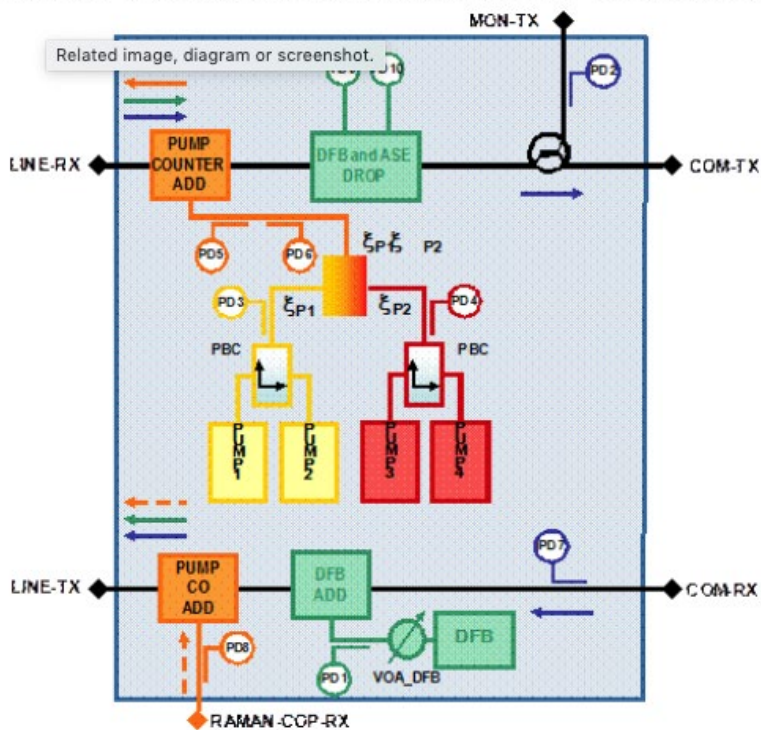
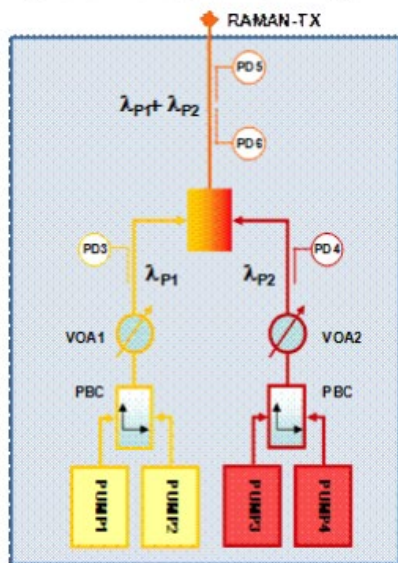

Figure 3. Functional Block Diagram for the Cisco ONS 15454 MSTP High-Power Co-Propagating Raman Amplifier



See also *id.* at Table 5:

Table 5. Optical Amplifier Specifications

Specification	Counter-Propagating Unit	Co-Propagating Unit
Pump wavelength	1428 nm (pumps 1 and 2) 1457 nm (pumps 3 and 4)	1428 nm (pumps 1 and 2) 1457 nm (pumps 3 and 4)
Raman pump unit class	1 M	1 M
Operating range Raman pump power	100 to 1000 mW	200 to 1000 mW
Maximum output power: pump laser 1+ 2 (1428 nm)	500 mW	550 mW
Maximum output power: pump laser 1+ 2 (1457 nm)	500 mW	500 mW
Pump-power set resolution	0.1 mW (maximum)	0.1 mW (maximum)
Pump-power precision	+ or - 2%	+ or - 2%
Optical power-settling time	0.1 to 1 sec	0.1 to 1 sec
Maximum optical output power - LINE Rx port	1200 mW (maximum)	1200 mW (maximum)
C-band signal wavelength range	1500 to 1567 nm (96 channels)	C-band wavelengths do not propagate through this card.

69. Further, the '383 Accused Instrumentalities, including the representative instrumentality, Charter's fiber-optic network, transmit optical signals in a signal wavelength range from 1530-1570 nm; counter-propagate optical energy in the first pump wavelength range from 1410 to 1480 nm (e.g., from 1428 nm to 1457 nm); and co-propagate optical energy in the second pump wavelength range from 1410 to 1430 nm (e.g., from 1428 nm to 1457 nm). *See, e.g., 15454 MSTP Datasheet* at Table 5:

Table 5. Optical Amplifier Specifications

Specification	Counter-Propagating Unit	Co-Propagating Unit
Pump wavelength	1428 nm (pumps 1 and 2) 1457 nm (pumps 3 and 4)	1428 nm (pumps 1 and 2) 1457 nm (pumps 3 and 4)
Raman pump unit class	1 M	1 M
Operating range Raman pump power	100 to 1000 mW	200 to 1000 mW
Maximum output power: pump laser 1+ 2 (1428 nm)	500 mW	550 mW
Maximum output power: pump laser 1+ 2 (1457 nm)	500 mW	500 mW
Pump-power set resolution	0.1 mW (maximum)	0.1 mW (maximum)
Pump-power precision	+ or - 2%	+ or - 2%
Optical power-settling time	0.1 to 1 sec	0.1 to 1 sec
Maximum optical output power - LINE Rx port	1200 mW (maximum)	1200 mW (maximum)
C-band signal wavelength range	1500 to 1567 nm (96 channels)	C-band wavelengths do not propagate through this card.

70. Discovery is expected to uncover the full extent of Charter's unlawful use of Optic153's patented technology in the '383 Patent beyond the '383 Accused Instrumentalities already identified through public information.

71. On information and belief, Charter also directly infringed at least Claims 1-2 of the '383 Patent by testing the '383 Accused Instrumentalities, including in relation to network testing and improvement responsive to user/customer feedback, and demonstration at trade shows, sales facilities, customer sites, and training/tutorial videos.

72. Plaintiff has suffered damages as a result of Charter's infringement of the '383 Patent.

73. Plaintiff reserves the right to modify its infringement theories as discovery progresses in this case. Plaintiff shall not be estopped for purposes of its infringement contentions or its claim constructions by the foregoing discussions on how the '383 Accused Instrumentalities infringe the '383 Patent. Plaintiff intends only that the foregoing discussions satisfy the notice requirements of Rule 8(a)(2) of the Federal Rule of Civil Procedure, and that they should not be construed as Plaintiff's preliminary or final infringement contentions or preliminary or final claim construction positions.

COUNT V - INFRINGEMENT OF U.S. PATENT NO. 6,587,261

74. Plaintiff incorporates and realleges the preceding paragraphs as if fully set forth herein.

75. The '261 Patent is directed to systems and methods for amplifying optical signals, as described and claimed in the '261 Patent.

76. Charter directly infringed at least Claims 1 and 10 of the '261 Patent, in this judicial District and elsewhere in the United States, pursuant to 35 U.S.C. § 271(a), literally or

under the doctrine of equivalents, by, among other things, by making, using, selling, offering to sell, and/or importing in or into the United States, without authority: products, devices, systems, and/or components of systems that supply optical energy in a plurality of pump wavelengths based on a characterized amplifier performance to control amplification signal wavelengths in an optical signal (“’261 Accused Instrumentalities”). The ’261 Accused Instrumentalities include, for example and without limitation, Charter’s optical communications networks and systems (e.g., Charter’s fiber-optic network) that employ Cisco’s ONS 15454 Series platform including associated hardware and software, and/or other telecommunications networks and systems that deploy or have deployed such platforms or components.

77. By way of example, the representative instrumentality, Charter’s fiber-optic network, employs Cisco’s ONS 15454 Multiservice Transport Platform and infringes the ’261 Patent. *See, e.g.*, “Charter Communications Enhances Business and Residential Service Delivery With Cisco IP NGN Architecture” *available at* <https://www.businesswire.com/news/home/20061018005208/en/Charter-Communications-Enhances-Business-Residential-Service-Delivery> (last visited Dec. 28, 2020); *see also* “The Charter Communications Opportunity for Cerent – When Competing Equipment Suppliers Don’t Execute,” *available at* <http://robkoslowsky.weebly.com/blog/the-charter-communications-opportunity-for-cerent-when-competing-equipment-suppliers-dont-execute> (last visited Dec. 28, 2020). The ONS 15454 Multiservice Transport Platform includes erbium doped fiber amplifiers (e.g., OPT-EDFA-17 and OPT-EDFA-24,) and Raman amplifiers (e.g., OPT-RAMP-C, OPT-RAMP-CE, and EDRA-x-xx). *See, e.g.*, Enhanced C-Band 96-Channel EDFA Amplifiers for the Cisco ONS 15454 MSTP Data Sheet (“**EDFA C-Band Datasheet**”) at 1, *available at* <https://www.cisco.com/c/en/us/products/collateral/optical-networking/ons-15454-series->

multiservice-transport-platforms/data_sheet_c78-658542.html (last visited Dec. 11, 2020); *see also* **Raman C-Band Datasheet** at 1. More specifically, the '261 Accused Instrumentalities, including the representative instrumentality, Charter's fiber-optic network, perform a method of amplifying optical signals comprising providing an optical amplifier (e.g., EDFA or Raman amplifiers) in an optical transmission fiber including an amplifying fiber configured to receive power as optical energy in a plurality of pump wavelengths. *See, e.g., Raman C-Band Datasheet* at 1 ("The OPT-RAMP-C features an embedded low-noise EDFA gain block for C-band optical amplification and optimized system performances with Raman amplification. The Raman pumps embedded in the unit use on the latest laser technology, enabling up to 500 milliwatts (mW) of power combining just two pump lasers, thus obtaining very high efficiency and low power consumption (Figure 2). ... A dedicated software application has been incorporated in Cisco Transport Controller to allow a fully automatic and simple configuration and tuning of the optical Raman amplifiers along a DWDM link. This software application, called Raman Tuning Wizard, can take advantage of tunable Transponder or Muxponder units to evaluate the physical characteristics of the span's fiber, determine the optimal mix of Raman pump wavelengths, and define the contribution of Raman versus EDFA for the overall optical amplification of the unit."); *see also id.* at Fig. 2:

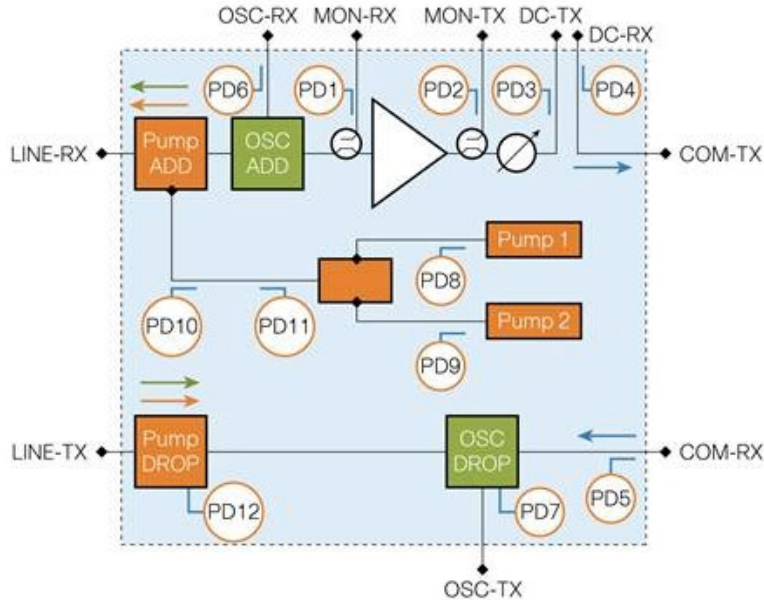
Figure 2. OPT-RAMP-C Block Diagram

See also **EDFA C-Band Datasheet** at 1 (“[Cisco True Variable Gain Booster Amplifiers] can also support the amplification of up to 96 channels in the C-band of the spectrum – 50-GHz-spaced ITU grid (wavelength range from 1528.77 to 1566.72 nm.)”); see also **Raman C-Band Datasheet** at 1 (“A Raman amplifier uses intrinsic properties of silica fibers to obtain signal amplification. This means that transmission fibers can be used as a medium for amplification, and hence that the intrinsic attenuation of data signals transmitted over the fiber can be combated within the fiber. An amplifier working on the basis of this principle is commonly known as a distributed Raman amplifier (DRA) or simply Raman amplifier. The OPT-RAMP-C unit not only embeds efficient next-generation pump lasers to generate counter-propagating Raman effect in the span fiber but also a low-noise Erbium Doped Fiber Amplifier (EDFA) to optimize the overall Noise Figure of the Node.”).

78. Also, the '261 Accused Instrumentalities, including the representative instrumentality, Charter’s fiber-optic network, characterize the amplifier performance for optical signals passing through the transmission fiber and amplifying fiber as a function of the optical

energy provided in the plurality of pump wavelengths. *See, e.g., Network Reference* at 1 (“Amplifiers monitor the changes to the input power and change the output power proportionately according to the calculated gain setpoint.”); *see also EDFA C-Band Datasheet at 1* (“Each card integrates software-controllable variable optical attenuators (VOAs) along with extensive optical monitoring with photo diodes, to provide nodal- and network-based automatic power-level management. Extensive optical safety algorithms provide user safety when operating the network.”); *see also id.* at Table 5:

Table 5. Optical Amplifier Specifications

Specification	17-dB Amplifier (15454-OPT-EDFA-17)	24-dB Amplifier (15454-OPT-EDFA-24)
Input power range (PIN)	Single channel at -5-dBm output power: -25 to -10 dBm	Single channel at -5-dBm output power: -32 to -17 dBm
Full-channel load or single-channel load	Full-channel load at 20-dBm output power: 0 to 15 dBm	Full-channel load at 20-dBm output power: -7 to 8 dBm
Output power range	-5 to 20 dBm	-5 to 20 dBm
Output power shut-off threshold	20.5 dBm	20.5 dBm
Standard gain range (with controlled gain tilt)	5 to 17 dB	12 to 24 dB
Extended gain range (with uncontrolled gain tilt)	17 to 20 dB	24 to 27 dB
Transient suppression	Refer to Table 7	Refer to Table 7

79. Further, the '261 Accused Instrumentalities, including the representative instrumentality, Charter's fiber-optic network, supply optical energy in the plurality of pump

wavelengths in an amount based on the characterized amplifier performance (e.g., to reach target power) to control the amplification of a plurality of signal wavelengths included in the optical signal. *See, e.g., Network Reference* at 1 (“After the GEDFA is set, APC regulates the power on the VOA (DC-TX port) of the OPT-RAMP-C or OPT-RAMP-CE card to match the target Power (COM-TX port) value, and accounts for the actual DCU loss.”); *see also Node Reference* at 1 (“The APC dynamically adjusts the tilt reference (TILT REFERENCE) value to meet the target taking into consideration the Raman tilt (TILT RAMAN) that the Raman installation wizard calculates and the EDFA tilt (TILT EDFA) that is calculated by the OPT-RAMP-C or OPT-RAMP-CE card based on its GEDFA value: $TILT\ CTP\ setpoint = TILT\ RAMAN + TILT\ EDFA + TILT\ REFERENCE$ ”).

80. Further, the '261 Accused Instrumentalities, including the representative instrumentality, Charter's fiber-optic network, perform a method of calibrating optical amplifier performance comprising installing an optical amplifier (e.g., EDFA or Raman amplifiers) in an optical transmission fiber. *See, e.g., Node Reference* at 1 (“Step 8 Route the fiber cable on the card faceplate through the fiber clip on the faceplate, if provided. (Fiber clips are factory-attached to the faceplates of 32MUX-O, 32DMX, 32DMX-O, OSCM, OSC-CSM, OPT-PRE, OPT-BST, OPT-BST-E, OPT-BST-L, OPT-AMP-L, OPT-AMP-17-C, OPT-AMP-C, OPT-RAMP-C, OPT-RAMP-CE, OPT-EDFA-17, OPT-EDFA-24, and OPT-EDFA-35 cards.”).

81. Further, the '261 Accused Instrumentalities, including the representative instrumentality, Charter's fiber-optic network, transmit test power through the transmission fiber and the optical amplifier and varying the power supplied to the optical amplifier. *See, e.g.,* “Cisco ONS 15454 DWDM Network Configuration Guide, Release 10.x.x, Chapter: Turning Up a Network” at Steps 8 and 9 of “Configure the Raman Pump Using the Installation Wizard”

(“Turning Up a Network”), available at

https://www.cisco.com/c/en/us/td/docs/optical/15000r10_0/dwdm/network_config/guide/b_ons_network_configuration/b_ons_network_configuration_chapter_010001.html (last visited Dec. 12, 2020) (turning on amplifiers and calibrating Raman amplification using a software installation wizard):

Step 8 Click **Next**. The Calibrate Raman Page is displayed (Figure 16-10).

Figure 10. Calibrating Raman Amplification

Day0 Raman Calibration

Routing Page
 Start Node: WXC_BSTE_Chira-155
 End Node: CLA2_CrownP-154

Setting Parameters
 Start Node: WXC_BSTE_C
 End Node: CLA2_CrownP
 Shelf: 2
 Slot: 17 (MXP_2_5A)
 Port: 5 (Trunk)
 Mux/Dmux not present
 Selected Lambda: 1530.33 nm

Calibrate Raman

Card on Node: WXC_BSTE_Chira-155 Card on Node: CLA2_CrownP-154

Shelf: 2 Shelf:
 Slot: 1 (OPT-RAMP CB) Slot: Slot 3 (OPT-RAMP...
 Port: RAMAN-TX/A Port: RAMAN-TX/A

Hints
 The following steps will be performed:
 1) The Booster present on the Start Node will be turned on.
 2) The OPT-RAMP card on the start node will be turned on.
 3) Received power and the End Node will be measured.

Repeat

Time Stamp: 16:11:37
 Low Power (dBm): -4.4
 High Power (dBm): 1.2

< Back Next > Finish Cancel Help

Step 9 As soon as the Raman calibrations are complete, the Next button is enabled. Click **Next**.

Figure 11. Calibrating Raman Amplification

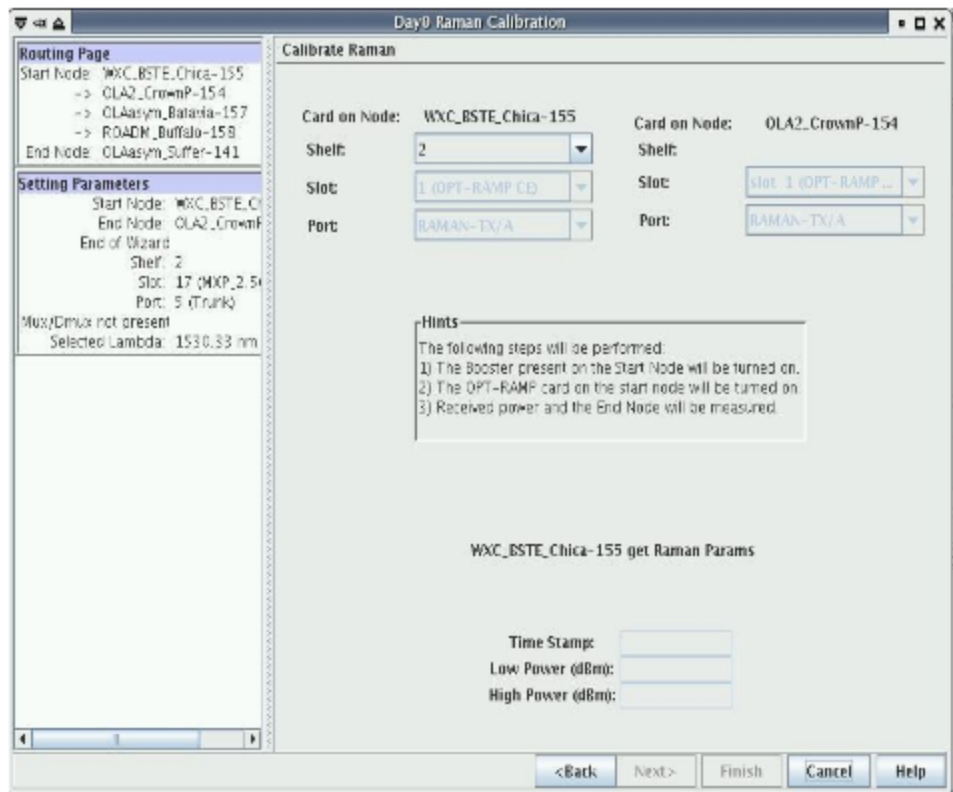

82. The '261 Accused Instrumentalities, including the representative instrumentality, Charter's fiber-optic network, measure the test power transmitted through the optical amplifier as a function of the power supplied to the optical amplifier; and, calculate amplifier performance parameters based on the measured test powers to characterize the amplification of a plurality of signal wavelengths as a function of the power supplied to the amplifier. *See, e.g., Turning Up a Network* at 1 (at Steps 12 and 13) of "Configure the Raman Pump Using the Installation Wizard" (measuring test power and calculating Raman gain):

Step 12 Click **Next**. The Accept Results page is displayed (Figure 16-12).

Figure 12. Raman Amplification Results

The screenshot shows the 'DayD Raman Calibration' window. On the left, there are sections for 'Setting Parameters' and 'Calibrate Raman'. The 'Accept Result' dialog box is open, displaying a 'Hints' message and an 'Exports Data' button. Below the button is a table with the following data:

Node	Card	Quality	Ratio	Tot Power ...	Gain	Tilt	Loss
OL22_Cro...	Slot 1, Por...	Well calibr...	35.5%	320	9.6	0.0	-4.4
OL22_Asym...	Slot 16, P...	Well calibr...	35.1%	309	8.7	0.0	-7.1

At the bottom right of the dialog, there are buttons for 'Finish', 'Cancel', and 'Help'. A vertical label '247653' is visible on the right edge of the window.

Step 12 Click Next. The Accept Results page is displayed (Figure 16-12).

Figure 12. Raman Amplification Results

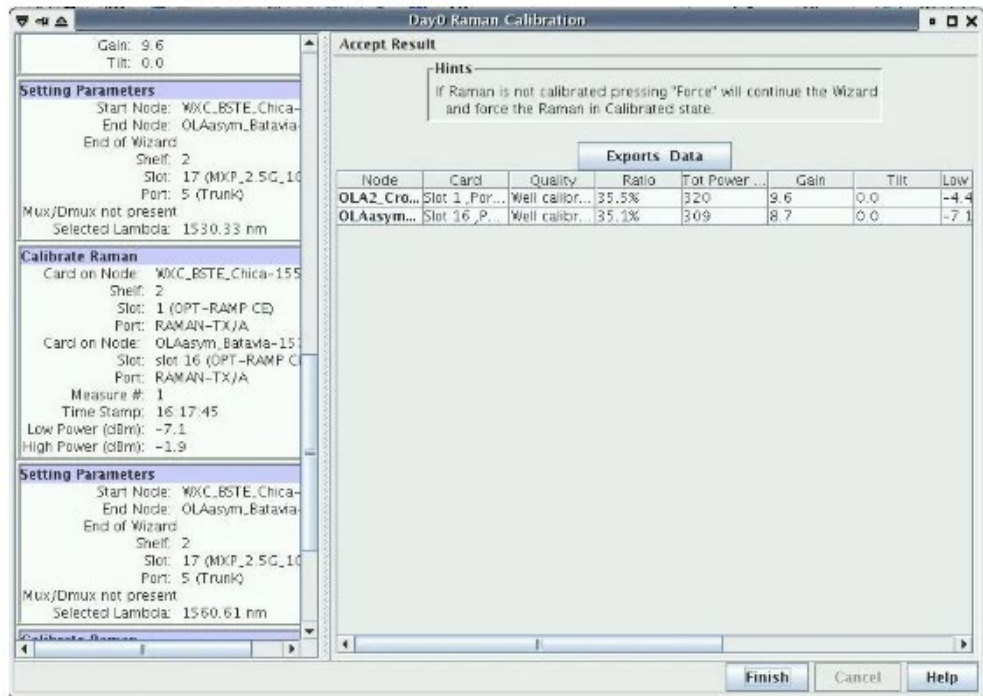

The calculated Raman power and Raman gain are displayed. (Figure 16-12.)

See also id. at Step 13 (The wizard compares the calculated Raman gain value with the expected results. Your action depends on the Raman gain values: Expected gain (Gt) – 0.5 dB <= (gain) <= (expected gain) + 0.5 dB—If the Raman gain is within this range, it means that the setup procedure was successful. Go to Step 14. (Expected gain) - 3.0 dB <= (gain) <= (expected gain) – 0.5 dB—If the Raman gain is within this range, it means that the values are slightly outside the range. The wizard recommends that you verify the span length and cabling, and repeat the installation wizard procedure.”).

83. Discovery is expected to uncover the full extent of Charter’s unlawful use of Optic153’s patented technology in the ’261 Patent beyond the ’261 Accused Instrumentalities already identified through public information.

84. On information and belief, Charter also directly infringed at least Claims 1 and 10 of the '261 Patent by testing the '261 Accused Instrumentalities, including in relation to network testing and improvement responsive to user/customer feedback, and demonstration at trade shows, sales facilities, customer sites, and training/tutorial videos.

85. Plaintiff has suffered damages as a result of Charter's infringement of the '261 Patent.

86. Plaintiff reserves the right to modify its infringement theories as discovery progresses in this case. Plaintiff shall not be estopped for purposes of its infringement contentions or its claim constructions by the foregoing discussions on how the '261 Accused Instrumentalities infringe the '261 Patent. Plaintiff intends only that the foregoing discussions satisfy the notice requirements of Rule 8(a)(2) of the Federal Rule of Civil Procedure, and that they should not be construed as Plaintiff's preliminary or final infringement contentions or preliminary or final claim construction positions.

COUNT VI - INFRINGEMENT OF U.S. PATENT NO. 6,771,413

87. Plaintiff incorporates and realleges the preceding paragraphs as if fully set forth herein.

88. The '413 Patent is directed to systems and methods for transmitting optical signals, as described and claimed in the '413 Patent.

89. Charter directly infringed at least Claims 1 and 10 of the '413 Patent, in this judicial District and elsewhere in the United States, pursuant to 35 U.S.C. § 271(a), literally or under the doctrine of equivalents, by, among other things, by making, using, selling, offering to sell, and/or importing in or into the United States, without authority: products, devices, systems, and/or components of systems that counter pump and co-pump optical energy to produce Raman

amplification in an optical fiber (“’413 Accused Instrumentalities”). The ’413 Accused Instrumentalities include, for example and without limitation, Charter’s optical communications networks and systems (e.g., Charter’s fiber-optic network) that employ counter-propagating (e.g., Cisco’s 15454-M-RAMAN-CTP card) and co-propagating (e.g., 15454-M-RAMAN-COP card) Raman units including associated hardware and software, ONS 15454 Series platform including associated hardware and software, and/or other telecommunications networks and systems that deploy or have deployed such platforms or components.

90. By way of example, the representative instrumentality, Charter’s fiber-optic network, employs Cisco’s ONS Series 15454 Multiservice Transport Platform and infringes the ’413 Patent. *See, e.g.*, “Charter Communications Enhances Business and Residential Service Delivery With Cisco IP NGN Architecture” *available at* <https://www.businesswire.com/news/home/20061018005208/en/Charter-Communications-Enhances-Business-Residential-Service-Delivery> (last visited Dec. 28, 2020); *see also* “The Charter Communications Opportunity for Cerent – When Competing Equipment Suppliers Don’t Execute,” *available at* <http://robkoslowsky.weebly.com/blog/the-charter-communications-opportunity-for-cerent-when-competing-equipment-suppliers-dont-execute> (last visited Dec. 28, 2020). The ONS Series 15454 Multiservice Transport Platform includes Raman amplifiers such as RAMAN-CTP, RAMAN-COP, 15454-M-RAMAN-CTP card, and 15454-M-RAMAN-COP card to amplify optical signals and to provide signal co-propagation and counter-propagation. An image of the 15454-M-RAMAN-CTP card and 15454-M-RAMAN-COP is also shown below:



See 15454 MSTP Datasheet at 1.

91. More specifically, the '413 Accused Instrumentalities, including the representative instrumentality, Charter's fiber-optic network, perform a method of transmitting optical signals comprising transmitting optical signals, in an optical signal wavelength range (e.g., 1500 to 1567 nm), via a transmission media (e.g., an optical fiber) and amplifying the optical signals a plurality of times at a plurality of separate locations (e.g., where the counter-propagating and co-propagating amplifiers are located along the transmission) to produce a composite optical signal gain profile, wherein amplifying includes counter pumping optical energy in the transmission media in a first pump wavelength range (e.g., 1428 nm to 1457 nm or ζ P1 and ζ P2 via Pumps 1-4) and co-pumping optical energy in the transmission media in a

second pump wavelength range (e.g., 1428 nm to 1457 nm or $\lambda P1$ and $\lambda P2$ via Pumps 1-4) to produce Raman amplification of the optical signals. See **15454 MSTP Datasheet** at 1 (“The high power counter-propagating unit injects counter-propagating optical power to generate a Raman effect in the span fiber and thus amplifies the signals propagating in the same fiber. Similarly, the co-propagating Raman unit injects co-propagating optical power that also amplifies the signal through a Raman effect in fiber. The signal thus receives amplification from the optical power injected by both these units present on opposite ends of the span”); *see also id.* at Figs. 2 and 3:

Figure 2. Functional Block Diagram for the Cisco ONS 15454 MSTP High-Power Counter-Propagating Raman Amplifier

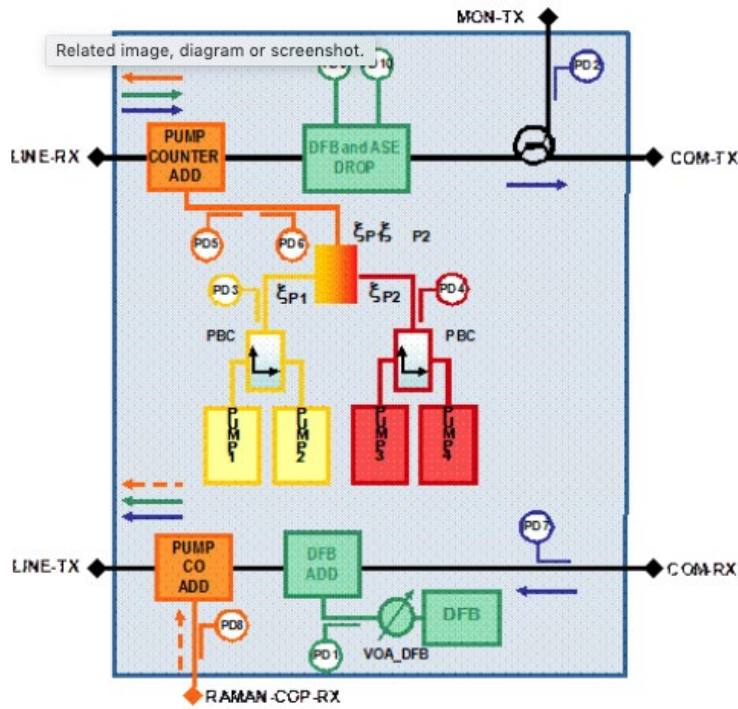
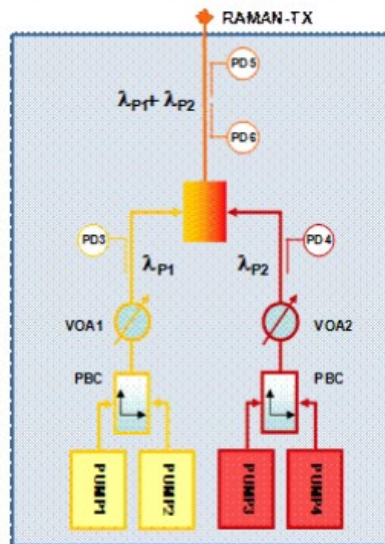
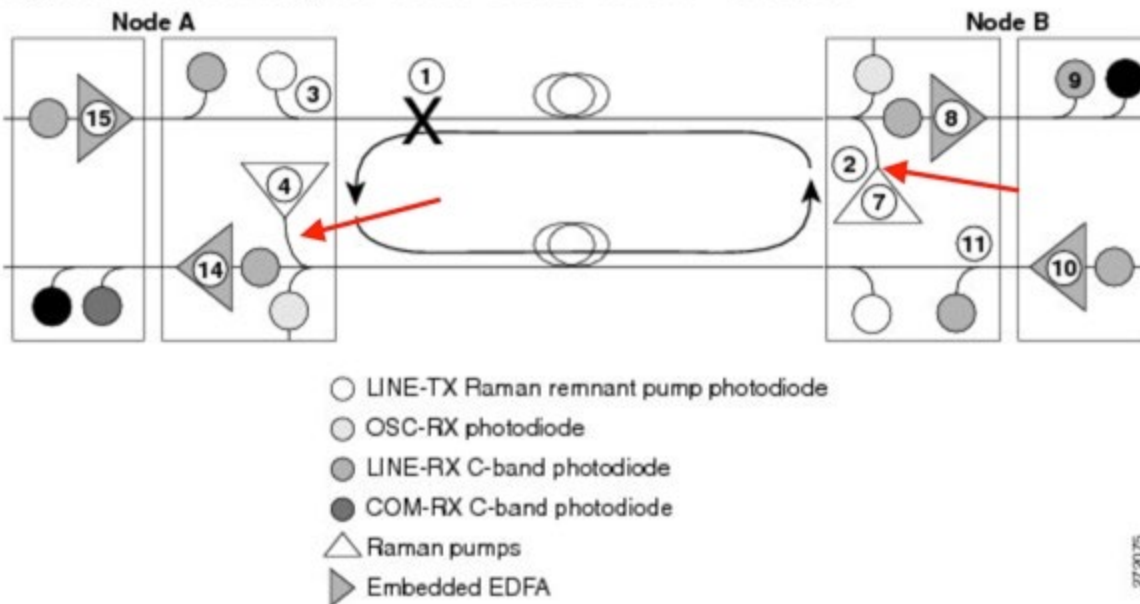

Figure 3. Functional Block Diagram for the Cisco ONS 15454 MSTP High-Power Co-Propagating Raman Amplifier



See also Network Reference at Fig. 30 (annotated):

Figure 30. Nodes Using OPT-RAMP-C or OPT-RAMP-CE Cards



92. Also, the '413 Accused Instrumentalities, including the representative instrumentality, Charter's fiber-optic network, counter pump to produce a counter pumping noise figure profile (e.g., as created by $\zeta P1$ and $\zeta P2$ via Pumps 1-4) over the optical signal wavelength range corresponding to the Raman amplification and co-pump to vary the counter pumping noise figure profile over at least a portion of the optical signal wavelength range (e.g., as created by $\lambda P1$ and $\lambda P2$ via Pumps 1-4). *See also* "Practical Aspects of Raman Amplifier," available at <https://www.cisco.com/c/en/us/support/docs/optical-networking/ons-15454-m6-multiservice-transport-platform-mstp/212834-practical-aspects-of-raman-amplifier.html> (last visited Apr. 1, 2020) ("Noise Sources Noise created in a DRA span consists: Amplified Spontaneous Emissions (ASE) Double Rayleigh Scattering (DRS) Pump Laser Noise ASE noise is due to photon generation by spontaneous Raman scattering. DRS noise occurs when twice reflected signal power due to Rayleigh scattering is amplified and interferes with the original signal as crosstalk noise. ... Counter pump DRA configuration results in better OSNR performance for signal gains of 15 dB and greater. ... For fibers with low DRS noise, the Raman noise figure due to ASE is

much better than the EDFA noise figure. Typically, the Raman noise figure is -2 to 0 dB, which is about 6 dB better than the EDFA noise figure.”); *see also* **Node Reference** at FIG. 7

(annotated):

Figure 7. 80-Channel Terminal Node with RAMAN-CTP and RAMAN-COP Cards Installed

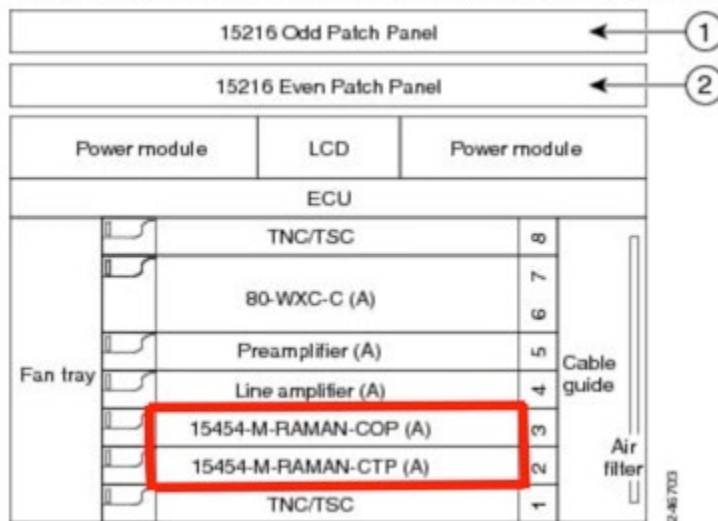

93. Also, the '413 Accused Instrumentalities, including the representative instrumentality, Charter's fiber-optic network, filter the composite optical signal gain profile produced by amplifying the optical signal a plurality of times (e.g., through a series of amplifiers) to produce a desired gain profile for the optical signals. *See also* **15454 MSTP Datasheet** at 1 (“To equalize the Raman gain ripple, the high-power Raman amplifiers must be equipped in nodes with equalization ability: either a dynamic gain-equalizer (DGE) node or a reconfigurable optical add/drop multiplexing (ROADM) node. Multiple options are possible and are detailed in Figures 4 through 6.”).

94. On information and belief, the '413 Accused Instrumentalities, including the representative instrumentality, Charter's fiber-optic network, produce a desired gain profile that is a flat gain profile (e.g., a constant gain). *See, e.g.*, Practical Aspects of Raman Amplifier at 1:

$$G_{R.on/off} = 10 \log \left(\frac{P_s(\text{pump.on,signal.on}) - P_{\text{noise}}(\text{pump.on,signal.off})}{P_s(\text{pump.off,signal.on})} \right)$$

See also **Raman C-Band Datasheet** at 1 (“The OPT-RAMP-C also provides an embedded fast Gain Control for transient suppression to respond quickly to network changes without impairments and degradation of existing wavelengths. In addition to this, the unit features an embedded Gain Flattening Filter (GFF) for the compensation of the ripple generated by the cascaded Raman and EDFA stages.”).

95. Discovery is expected to uncover the full extent of Charter’s unlawful use of Optic153’s patented technology in the ’413 Patent beyond the ’413 Accused Instrumentalities already identified through public information.

96. On information and belief, Charter also directly infringed at least Claims 1 and 10 of the ’413 Patent by using the ’413 Accused Instrumentalities, including in relation to product testing and improvement responsive to user/customer feedback, and demonstration at trade shows, sales facilities, customer sites, and training/tutorial videos.

97. Plaintiff has suffered damages as a result of Charter’s infringement of the ’413 Patent.

98. Plaintiff reserves the right to modify its infringement theories as discovery progresses in this case. Plaintiff shall not be estopped for purposes of its infringement contentions or its claim constructions by the foregoing discussions on how the ’413 Accused Instrumentalities infringe the ’413 Patent. Plaintiff intends only that the foregoing discussions satisfy the notice requirements of Rule 8(a)(2) of the Federal Rule of Civil Procedure, and that they should not be construed as Plaintiff’s preliminary or final infringement contentions or

preliminary or final claim construction positions.

PRAYER FOR RELIEF

WHEREFORE, Plaintiff demands judgment for itself and against Defendant Charter as follows:

- A. A judgment that Defendant has infringed one or more claims of each of the Asserted Patents;
- B. A judgment awarding Plaintiff all damages adequate to compensate for Defendant's infringement, and in no event less than a reasonable royalty for Defendant's acts of infringement, including all pre-judgment and post-judgment interest at the maximum rate allowed by law;
- C. A judgment and order finding that this is an exceptional case within the meaning of 35 U.S.C. § 285 and awarding Plaintiff its reasonable attorneys' fees; and
- D. A judgment awarding Plaintiff such other relief as the Court may deem just and equitable.

DEMAND FOR JURY TRIAL

Pursuant to Rule 38(b) of the Federal Rules of Civil Procedure, Plaintiff demands a trial by jury of this action.

Dated: January 29, 2021

DEVLIN LAW FIRM LLC

/s/ Timothy Devlin

Timothy Devlin (*pro hac vice application pending*)

tdevlin@devlinlawfirm.com

Alex Chan

Texas State Bar No. 24108051

achan@devlinlawfirm.com

1526 Gilpin Ave.

Wilmington, Delaware 19806

Telephone: (302) 449-9010

Facsimile: (302) 353-4251

Attorneys for Plaintiff,

Optic153 LLC.