

**IN THE UNITED STATES DISTRICT COURT
FOR THE SOUTHERN DISTRICT OF FLORIDA**

LANDMARK TECHNOLOGY A, LLC,

Plaintiff,

v.

LIFE'S ABUNDANCE, INC.,

Defendant.

CASE NO.:

TRIAL BY JURY DEMANDED

COMPLAINT FOR PATENT INFRINGEMENT

COMES NOW, Plaintiff Landmark Technology A, LLC ("Landmark A"), for its Complaint against Life's Abundance, Inc. ("Defendant" or "Life's Abundance"), alleges as follows:

THE PARTIES

1. Plaintiff Landmark Technology A, LLC ("Landmark A") is a limited liability company organized under the laws of the State of North Carolina.

2. On information and belief, Life's Abundance is a company organized under the laws of Florida with a principal place of business located at 101 Capital Street, Jupiter, Florida 33458. Landmark A is further informed and believes, and on that basis alleges, that Life's Abundance operates the website www.lifesabundance.com, which sells health products for people and pets. Life's Abundance derives a significant portion of its revenue from sales and distribution via electronic transactions conducted on and using at least, but not limited to, the Internet websites located at <https://www.lifesabundance.com> and/or the functionality found through the "login" and "basket" functions, and incorporated and/or related systems (collectively the "Life's Abundance Website" or "Accused Instrumentality"). Landmark A is informed and believes, and on that basis

alleges, that, at all times relevant hereto, Life's Abundance has done and continues to do business in this judicial district, including, but not limited to, providing products/services to customers located in this judicial district by way of the Life's Abundance Website.

JURISDICTION AND VENUE

3. This is an action for patent infringement in violation of the Patent Act of the United States, 35 U.S.C. §§ 1 *et seq.*

4. This Court has original and exclusive subject matter jurisdiction over the patent infringement claims for relief under 28 U.S.C. §§ 1331 and 1338(a).

5. This Court has personal jurisdiction over Life's Abundance because maintains its principal place of business in the state of Florida. On information and belief, Life's Abundance has transacted and is continuing to transact business in this District that includes, but is not limited to, the use of products and systems that practice the subject matter claimed in the patents involved in this action.

6. Venue is proper in this district under 28 U.S.C. § 1400(b) because Life's Abundance is registered with the Secretary of State in the State of Florida and thus resides in this district under the Supreme Court's opinion in *TC Heartland LLC v. Kraft Foods Group Brands LLC*, 137 S. Ct. 1514 (2017). Further, upon information and belief, Life's Abundance has committed acts of infringement in this district and a regular and established place of business in this district.

FACTS

7. On March 7, 2006, United States Patent No. 7,010,508 entitled "Automated Multimedia Data Processing Network" was duly and legally issued to Lawrence B. Lockwood as

inventor. A true and correct copy of United States Patent No. 7,010,508 (“the ‘508 Patent”) is attached hereto as Exhibit A and incorporated herein by this reference.

8. Specifically, the ‘508 Patent claims a novel automated multimedia data processing system, including an interactive multimedia terminal or “station” employing an unconventional hardware architecture enabling an inventive form of data processing according to backward-chaining and forward-chaining sequences.

9. By January 24, 1986—the date to which the Asserted Claim of the ‘508 Patent claims priority—conventional “self-service terminals,” such as that disclosed in U.S. Pat. No. 4,359,631 (“the ‘631 Patent”), had “evolved to a high degree of sophistication.” Ex. A, 1:37-40. A true and correct copy of the ‘631 Patent is attached as Exhibit B and incorporated herein by this reference. In spite of their sophistication, however, conventional terminals of the day were nonetheless incapable of “the more complex types of goods and services distribution which requires a great deal of interaction between individuals and institutions.” Ex. A, 1:39-44. In particular, conventional terminals were incapable of “processing” “according to backward-chaining and forward-chaining sequences,” as claimed in Claims 1 and 16 of the ‘508 Patent. Conventional terminals were also incapable of “analyzing” “operator-entered information” and, “responsive to said means for analyzing,” “presenting additional inquiries in response to said operator-entered information,” as claimed in Claim 1 of the ‘508 Patent. Thus, in the ‘631 Patent—which disclosed Mr. Lockwood’s own prior terminal and was the principal piece of prior art to the ‘508 Patent, explicitly identified therein as among the most sophisticated terminals of its day—employed a menu-driven approach to interaction with the user. As the inventor explained during prosecution of the ‘508 Patent, the “procedure [of the prior art terminal disclosed in the ‘631 Patent] followed a rigid, pre-ordained sequence...following a fixed menu tree.” A true and correct

copy of the inventor's amendment during prosecution of the '508 Patent is attached hereto as Exhibit C and incorporated herein by this reference. *See* Ex. C at 16. "In this primitive type of interactive process, the machine need not analyze the answer because each answer leads progressively to the next predetermined step in accordance with the sequence imposed by the menu tree." *Id.* By contrast, "the claimed system" of the '508 Patent "has the novel capability of processing the answer given by the operator in combination with prior answers and/or other data to formulate or compose a new inquiry, to request other information from a central processor, or a response, and to make on-site decisions about the next operational step. The net effect and result being the operator's responses create a highly individualized, unique, 'one-of-a-kind' question and answer presentation." *Id.* at 20. Whereas the terminal of the '631 patent employed a "backward-chaining" approach, the '508 Patent "employs a type of problem solving technique known in the art as 'forward-chaining,'" a technique "associated with knowledge bases that have large numbers of possible solutions." *Id.* at 21-24. "Because each proposed applicant" using the terminal (or "station") of the '508 Patent "will provide different answers to earlier questions, the proposed applicant may be provided with subsequent questions different from those posed to some other proposed applicant." *Id.* at 24. In other words, each user of the claimed system of the '508 Patent "will be provided with an individualized presentation." *Id.* These capabilities are reflected in the "processing" according to "backward-chaining and forward-chaining sequences" elements of Claims 1 and 16, as well as the "means for analyzing" element of Claim 1.

10. As a three-judge panel of the Board of Patent Appeals and Interferences unanimously recognized, the prior art terminal of the '631 Patent did "not disclose both 'backward-chaining and forward-chaining sequences.'" A true and correct copy of the Board's decision is attached as Exhibit D, and incorporated herein by this reference. *See* Ex. D at 5. Employing both

backward-chaining and forward-chaining sequences in an automated multimedia data processing system, as claimed in Claim 1 and 16 of the '508 Patent, was an inventive concept and unconventional in 1986, rendering the claims eligible under 35 U.S.C. § 101. However, for such a system to carry out a properly interactive presentation required hardware improvements that would enable the terminal to support an interactive video presentation while at the same time receiving and transmitting data to and from a computerized installation. For example, as explained during prosecution, the “means for interactively directing” element specifically requires “selective retrieval of the data received through and from the central processor” and the “phrase ‘interactively directing’” was explicitly defined as “refer[ring] to the ability of the various cited elements to ‘interact’, that is to exchange information and act in accordance with received data,” i.e., data received from the central processor. Ex. C at 19. The “means for interactively directing,” as limited by or in combination with the requirement for “processing” “according to backward-chaining and forward-chaining sequences” in Claims 1 and 16, required a hardware architecture capable of supporting the retrieval of data from the central processor via the data receiving and transmitting means while supporting an interactive video presentation on the video display. Such a system would then be able not only to “process[] a user entry in combination with extrinsic information” obtained from the central processor (such as “the financial profile of the customer”) via the data receiving and transmitting means, “but to make suggestions, or independently provide something different than what was requested but more responsive to the user’s needs” and output it via the video display. Ex. C. at 19-20. But attempting to perform these functions at the same time on the prior art terminals of the early-to-mid 1980’s, such as that disclosed in the ’631 Patent, would have resulted in the congestion of their systems, rendering them virtually inoperable. These technical limitations of the prior art terminals were recognized by persons of ordinary skill in the

art, as evidenced by the declaration of Joey A. Maitra, an engineer with extensive experience in the relevant subject matter who held multiple positions in industry during the 1980's. A true and correct copy of the Maitra Declaration is attached as Exhibit E, and incorporated herein by this reference.

11. The structure employed by the prior art terminal of the '631 Patent had, by 1986, become conventional. That structure, and its technical limitations, are representative of terminals of the period. As shown in Figure 8 of the '631 Patent annotated below, the terminal "employs a bi-directional parallel bus oriented input/output structure." Ex. B, 4:57-59 & Fig. 8.

'631 Patent, Figure 8 (annotated) – The Prior Art Terminal and its Single, Shared Information Handling Connection

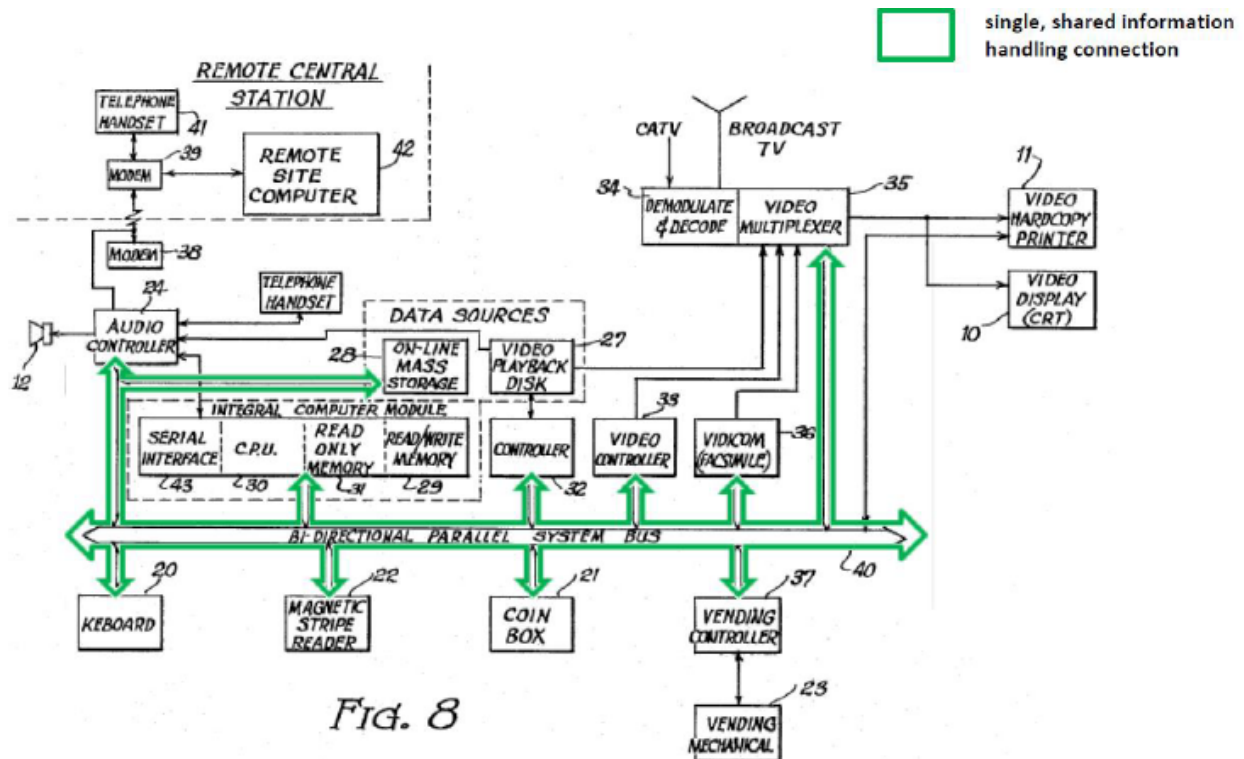

This information handling connection—bus 40—was *shared* among the terminal’s systems. Ex. B, 4:62-64 (noting this “structure . . . accommodate[s] the various terminal components.”). This structure presented a significant technical problem: in order to carry provide a higher degree of interactivity appropriate to the “more complex” transactions the ‘508 Patent sought to carry out, the terminal’s video playback and communication systems would have been required to operate at the same time. However, persons of ordinary skill in the art would have recognized that this would have exhausted the data transfer capacity of conventional terminals. Ex. E [Maitra Decl.] ¶¶ 12, 14, 23.

12. To solve these issues, the ‘508 Patent introduced a novel hardware improvement in the terminal (here claimed as a “station”). As demonstrated in Figure 2 of the ‘508 Patent annotated below, a DMA unit was positioned independently along its own information

‘508 Patent, Figure 2 (annotated) – Unconventional Arrangement of DMA Within a Second, Independent Information Handling Connection

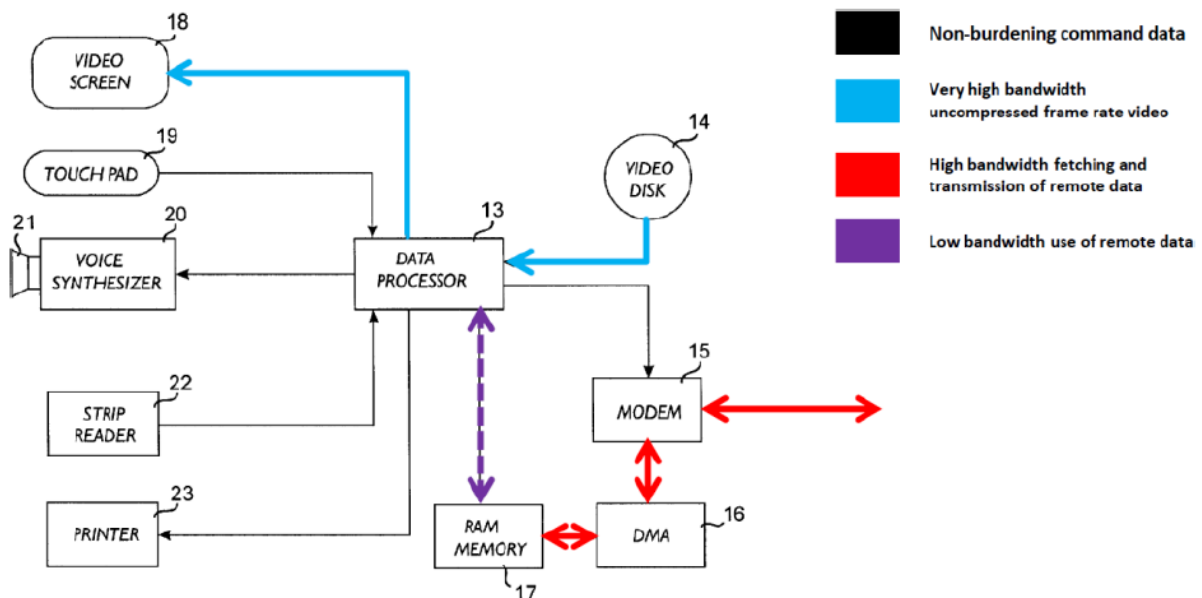

handling connection within the terminal, unlike the systems of the prior art. Ex. A, Fig. 2. Whereas prior art terminals would have incorporated a DMA unit into a single information handling connection shared among their systems (such as that illustrated in Fig. 8 of the ‘631 Patent), the ‘508 Patent disclosed two independent information handling connections designed to prevent congestion resulting from concurrent operation of the terminal’s systems (here claimed as a “station”). Ex. E [Maitra Decl.] ¶¶ 15, 23. As the specification of the ‘508 Patent explains, the terminal’s modem “handles a batch of information through a direct memory access [DMA] unit 16, to and from a RAM memory”—i.e., placing information directly into memory along an independent information handling connection, and not, as in the prior art, by first traversing a shared connection already bogged down by other systems. Ex. A, 3:41-43; Ex. E [Maitra Decl.] ¶¶ 17-19; 21-23. This unconventional hardware architecture enabled a higher level of interactivity and personalization of user transactions than was possible on conventional terminals in 1986, such as that disclosed in the ‘631 Patent. Persons of ordinary skill in the art would have recognized that the architecture of the terminal claimed in the ‘508 Patent overcame the technical limitations of conventional terminals, enabling the terminal to provide a richer interactive presentation to the user while simultaneously utilizing its communication systems to fetch necessary data from remote sources. *See* Ex. E [Maitra Decl.] ¶ 15. This unconventional hardware architecture disclosed in Figure 2 and elsewhere in the specification of the ‘508 Patent is required throughout many of the claim elements of Claims 1 and 16, particularly the “means for interactively directing,” and constitutes one of the ‘508 Patent’s “inventive concepts,” rendering the claims eligible under 35 U.S.C. § 101. Another of the ‘508 Patent’s “inventive concepts,” which is enabled by its structure, is “an unconventional analytic technique whereby the claimed station is capable of analyzing data to determine if an additional inquiry is appropriate for presentation to the user,” reflected in the

“means for processing” element of Claim 1. Ex. E [Maitra Decl] ¶ 19. That inventive concept goes beyond the subjective selection of the user and “stands out from the prior art where the operation of the information and goods dispensing machines was guided by rigid search and retrieval routines...through which the user could be provided only with the exact thing he had entered on the keyboard.” Ex. C at 19. In contrast to the conventional systems at the time of invention, the “claimed structure [of the ‘508 Patent] has the capability of, not only processing a user entry in combination with extrinsic information, but to make suggestions, or independently provide something different than what was requested but more responsive to the user’s needs.” *Id.*

13. Following a reexamination of the ‘508 Patent, the United States Patent and Trademark Office issued an Ex Parte Reexamination Certificate, US 7010508 C1, confirming the validity of Claims 1-7 and Claims 16-17, while cancelling Claims 8-15, which were much broader than those held valid. A true and copy of the Ex Parte Reexamination Certificate is attached hereto as Exhibit F and incorporated herein by this reference. As the PTO Examiner observed in confirming the validity of Claims 1-7 and 16-17 of the ‘508 Patent, the prior art “disclosures teach away” from those claims. A true and correct copy of the Examiner’s Office Action is attached hereto as Exhibit G, and incorporated herein by this reference. *See* Ex. G at 98. The Examiner thus rejected the third-party requester’s “uncollaborated [sic] conclusions” that the combination of backward and forward-chaining techniques claimed in the ‘508 Patent “would have been considered obvious” or would have required “only mere software changes,” instead holding Claims 1-7 and 16-17 valid. *Id.*

14. Landmark A is the exclusive licensee of the entire right, title and interest in and to the ‘508 Patent, including all rights to enforce the ‘508 Patent and to recover for infringement. The ‘508 Patent is valid and in force.

15. As more fully laid out below, Life's Abundance has been and is now infringing the '508 Patent, in this judicial district and elsewhere, by providing its products/services using electronic transaction systems, which, individually or in combination, incorporate and/or use subject matter claimed by the '508 Patent.

FIRST CLAIM FOR RELIEF

(Direct Infringement of the '508 Patent, in Violation of 35 U.S.C. § 271(a))

16. Landmark A refers to and incorporates herein by reference paragraphs 1-16.

17. Life's Abundance has directly infringed, and continues to directly infringe, at least Claim 1 of the '508 Patent in this judicial district and elsewhere in the state of Florida and the United States, through the sales and distribution via electronic transactions conducted on and using at least, but not limited to, the Life's Abundance Website.

18. The Life's Abundance Website functionality referenced above is "an automated multimedia system for data processing" practicing the claims of the '508 Patent.

19. By way of example only, and without limitation, the Accused Instrumentality infringes at least Claim 1 of the '508 Patent in that, the Life's Abundance Website's functionality and supporting server provide a system that, when accessed by a station, practices all of the limitations at least Claim 1 on which Life's Abundance processes business information and places purchase orders. Landmark A has outlined a sample of Life's Abundance's infringement of Claim 1 in the claim chart attached as Exhibit H and hereby incorporated by this reference.

20. Further, on information and belief, Life's Abundance's Website exerts control over the transactions placed via the claimed station. On information and belief, when the station's browser accesses Life's Abundance's Website, Life's Abundance's server causes the browser to

place a “cookie” on the claimed station, which allows users to store items in the website’s shopping cart.

21. Life’s Abundance, on information and belief, is also engaged in internal use of the claimed system, by developing and testing versions of its Website on its own computers. For example, Life’s Abundance employs an “IT Project Manager.” See <https://www.linkedin.com/in/kevinryan85/>. Life’s Abundance, therefore, by the acts complained of herein, is making, using, selling, or offering for sale in the United States, including in this District, products and/or services embodying the invention, and has in the past and is now continuing to infringe the ’508 Patent, either literally or under the doctrine of equivalents, in violation of 35 U.S.C. § 271(a).

22. Life’s Abundance threatens to continue to engage in the acts complained of herein and, unless restrained and enjoined, will continue to do so, all to Landmark A’s irreparable injury. It would be difficult to ascertain the amount of compensation that would afford Landmark A adequate relief for such future and continuing acts, and a multiplicity of judicial proceedings would be required. Landmark A does not have an adequate remedy at law to compensate it for the injuries threatened.

23. By reason of the acts of Life’s Abundance alleged herein, Landmark A has suffered damage in an amount to be proved at trial.

24. Landmark A is informed and believes, and on that basis alleges, that the infringement by Life’s Abundance is willful, wanton, and deliberate, without license and with full knowledge of the ’508 Patent, thereby making this an exceptional case entitling Landmark A to attorneys’ fees and enhanced damages.

SECOND CLAIM FOR RELIEF

(Inducing Infringement of the '508 Patent, in Violation of 35 U.S.C. § 271(b))

25. Landmark A refers to and incorporates herein by reference paragraphs 1-27.

26. Landmark A is informed and believes, and on that basis alleges, that Life's Abundance has actively and knowingly induced infringement of the '508 Patent, in violation of 35 U.S.C. § 271(b) by, among other things, inducing its customers to utilize their own device in combination with the Life's Abundance Website, and incorporated and/or related systems, to search for and order information and products from the Life's Abundance Website in such a way as to infringe the '508 Patent.

27. For example, Life's Abundance is inducing its customers to infringe by encouraging them to create new accounts and to sign into their accounts using their login information to retrieve their customer information.

28. By reason of the acts of Life's Abundance alleged herein, Landmark A has suffered damage in an amount to be proved at trial.

29. Life's Abundance threatens to continue to engage in the acts complained of herein and, unless restrained and enjoined, will continue to do so, all to Landmark A's irreparable injury. Landmark A does not have an adequate remedy at law.

30. Landmark A is informed and believes, and on that basis alleges, that the infringement by Life's Abundance is willful, wanton, and deliberate, without license and with full knowledge of the '508 Patent, thereby making this an exceptional case entitling Landmark A to attorneys' fees and enhanced damages.

PRAYER FOR RELIEF

WHEREFORE, Landmark A prays for relief as follows:

A. Judgment that Life's Abundance has directly infringed, and induced others to infringe, the '508 Patent either literally and/or under the doctrine of equivalents;

B. Judgment that Life's Abundance's infringement of the '508 Patent has been willful;

C. Judgment permanently enjoining Life's Abundance, its officers, directors, agents, servants, affiliates, employees, subsidiaries, divisions, branches, parents, attorneys, representatives, and all others acting in concert or privity with any of them, from infringing the '508 Patent, and from inducing others to infringe the '508 Patent;

D. Judgment awarding Landmark A general and/or specific damages, including a reasonable royalty and/or lost profits, in amounts to be fixed by the Court in accordance with proof, including enhanced and/or exemplary damages, as appropriate, as well as all of Life's Abundance's profits or gains of any kind from its acts of patent infringement;

E. Judgment awarding Landmark A enhanced damages pursuant to 35 U.S.C. § 284 due to the willful and wanton nature of Life's Abundance's infringement;

F. Judgment awarding Landmark A all of its costs, including its attorneys' fees, incurred in prosecuting this action, including, without limitation, pursuant to 35 U.S.C. § 285 and other applicable law;

G. Judgment awarding Landmark A pre-judgment and post-judgment interest; and

H. Judgment awarding Landmark A such other and further relief as the Court may deem just and proper.

JURY DEMAND

Pursuant to Federal Rule of Civil Procedure 38(b), Landmark A hereby demands a trial by jury on all issues triable to a jury.

Dated: May 11, 2021

Respectfully submitted,

/s/ Howard L. Wernow
Howard L. Wernow, B.C.S
Fla Bar No. 107560
Aegis Tower – Suite 1100
4940 Munson Street NW
Canton, Ohio 44718
Telephone: 330-244-1174
Facsimile: 330-244-1173
howard.wernow@sswip.com

*Board Certified in Intellectual Property Law
by the Florida Bar*

John A. Lee (*pro hac vice forthcoming*)
jlee@banishlaw.com
Banie & Ishimoto LLP
3705 Haven Ave., #137
Menlo Park, CA 94025
T: 650.241.2774
F: 650.241.2770

Attorneys for Plaintiff
Landmark Technology A, LLC