

**UNITED STATES DISTRICT COURT
FOR THE WESTERN DISTRICT OF TEXAS
WACO DIVISION**

MOTION OFFENSE, LLC,

Plaintiff

v.

DROPBOX, INC.

Defendant.

Civil Action No.: 6:21-cv-758

JURY TRIAL DEMANDED

PATENT CASE

COMPLAINT FOR PATENT INFRINGEMENT

Plaintiff Motion Offense, LLC (“Motion Offense” or “Plaintiff”), files this Complaint against Dropbox, Inc. (“Dropbox” or “Defendant”) seeking damages and other relief for patent infringement, and alleges with knowledge to its own acts, and on information and belief as to other matters, as follows:

PARTIES

1. Plaintiff is a limited liability company organized and existing under the laws of the State of Texas, having its principal place of business at 211 West Tyler Street, Suite C, Longview, Texas, 75601.

2. Defendant Dropbox is a Delaware corporation with a physical address at 501 Congress Ave, Austin, TX 78701. Dropbox may be served with process through its registered agent, the Corporation Service Company, at 211 East 7th Street, Suite 620, Austin, Texas 78701. Dropbox is registered to do business in the State of Texas and has been since at least October 3, 2013.

3. This Court has personal jurisdiction over Dropbox at least because Dropbox regularly conducts and transacts business, including infringing acts described herein, in this District.

4. Defendant conducts business in Texas, directly or through intermediaries and offer products or services, including those accused herein of infringement, to customers, and potential customers located in Texas, including in the Western District of Texas.

JURISDICTION AND VENUE

5. This action arises under the patent laws of the United States, 35 U.S.C. §101, et seq. This Court has subject matter jurisdiction under 28 U.S.C. §§1331 and 1338(a).

6. Venue is proper in this judicial district pursuant to 28 U.S.C. §1400(b). Dropbox maintains an established place of business in the state of Texas and the Western District of Texas, specifically, including an office at 501 Congress Ave, Austin, TX 78701.

7. Defendant is subject to this Court's specific and general personal jurisdiction pursuant to due process or the Texas Long Arm Statute, because Defendant conducts substantial business in this forum, including: (i) making, using, selling, importing, and/or offering for sale one or more cloud-based applications, but not limited to Dropbox Products, stored and/or hosted on one or more servers owned or under the control of Dropbox; (ii) making, using, selling, importing, and/or offering for sale software for smartphones, tablets, and other computing devices (e.g., laptops, desktops, Chromebooks, etc.); or (iii) regularly doing or soliciting business, engaging in other persistent courses of conduct, or deriving substantial revenue from goods and services provided to citizens and residents in Texas and in this District.

THE PATENT IN SUIT

8. On February 27, 2020, Robert Paul Morris filed United States Patent Application No. 16/803980 (“the ’980 Application”). The ’980 Application was duly examined and issued as United States Patent No. 11,044,215 (“the ’215 patent”) (entitled “Methods, Systems, and Computer Program Products for Processing a Data Object Identification Request in a Communication”), on June 22, 2021.

9. Motion Offense is the owner of the ’215 patent and has the full and exclusive right to bring actions and recover past, present, and future damages for Dropbox’s infringement of the ’215 patent.

10. The ’215 patent is valid and enforceable. A true and correct copy of the ’215 patent is attached hereto as Exhibit 1.

11. Motion Offense has not practiced any claimed invention of the ’215 patent.

COUNT I: INFRINGEMENT OF U.S. PATENT NO. 11,044,215

12. The allegations set forth in the foregoing paragraphs 1 through 11 are incorporated into this Claim for Relief.

13. The ’215 patent describes and claims systems and methods which make data sharing more rapid and efficient by allowing for the “processing a data object in a data object identification request in communication.” (’215 patent, Ex. 1 at 2:8-10.)

14. Among the specific technologic improvements to devices and methods for making data sharing more rapid and efficient, the ’215 patent describes systems and methods for “receiv[ing] . . . data object information ” *See, e.g.*, ’215 patent, Ex. 1 at 27:41-42 and 27:50- (“[A] system for processing a data object identification request in a communication includes means for sending, according to a first communications protocol via a network in a communication to a

second communications agent in a second execution environment representing a second user, a first message including a data object identification request based on the data object matching criterion, wherein the first message is addressed to the second user.”) Figure 7 of the ’215 patent, reproduced below, illustrates an exemplary data and execution flow for processing a data object identification request in a communication according to an aspect of the subject matter described in the ’215 patent:

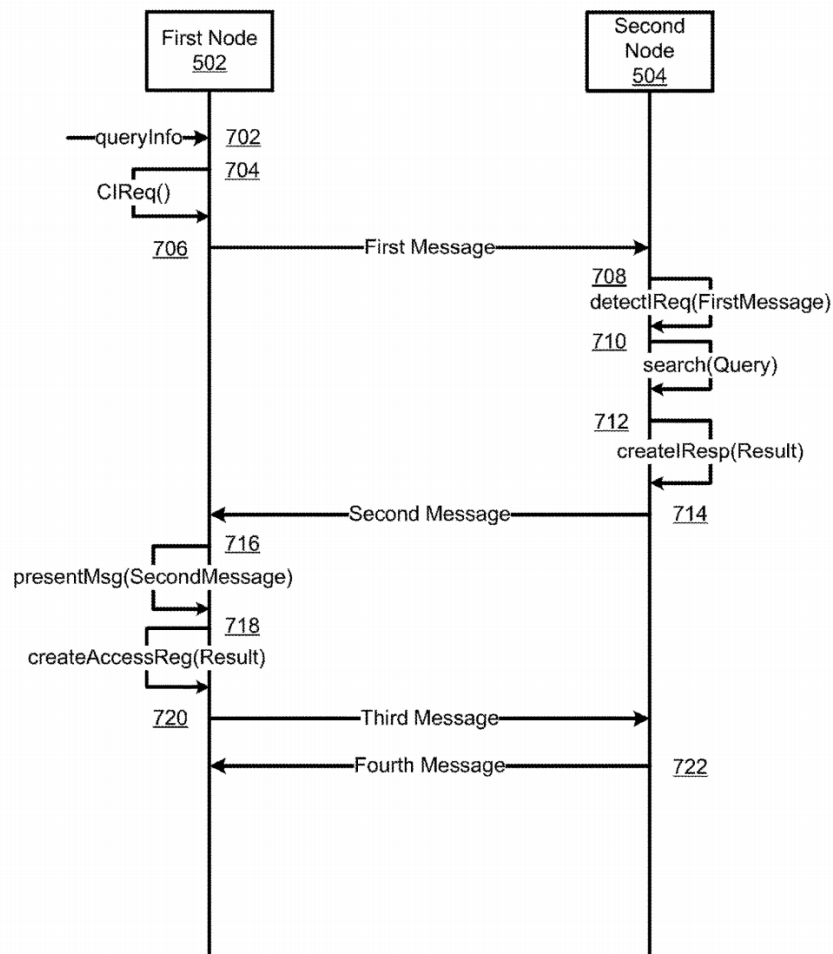

FIG. 7

(’215 patent, Ex. 1, Fig. 7.)

15. The claims of the '215 patent do not merely recite the performance of some business practice known from the pre-Internet world along with the requirement to perform it on the Internet. Instead, the claims of the '215 patent recite one or more inventive concepts that are rooted in computerized data sharing technology, and overcome problems specifically arising in the realm of computerized data sharing technologies.

16. The claims of the '215 patent recite an invention that is not merely the routine or conventional use of data sharing systems and methods. Instead, the invention describes systems and methods which make data sharing more rapid and efficient.

17. The technology claimed in the '215 patent does not preempt all ways of using data sharing tools nor preempt the use of all data sharing tools, nor preempt any other well-known or prior art technology.

18. Accordingly, each claim of the '215 patent recites a combination of elements sufficient to ensure that the claim in practice amounts to significantly more than a patent on an ineligible concept.

19. The '215 patent includes 80 claims. ('215 patent, Ex. 1 at cols. 49-65.)

20. Dropbox has been and is directly infringing, either literally or under the doctrine of equivalents, at least claim 1 of the '215 patent by making, using (including without limitation testing), selling, importing, and/or offering to sell products and systems, including by way of example, the Dropbox website (https://www.dropbox.com/?_hp=b&landing=dbv2) and servers, and other Dropbox products (together, the "Accused Instrumentalities"). *See* Claim Charts for the '215 patent, Exhibit 2. As demonstrated by the attached claim chart, each and every element of claim 1 of the '215 patent is found in the Accused Instrumentalities.

21. Dropbox's acts of infringement have occurred within this District and elsewhere throughout the United States.

22. Motion Offense has been harmed by Dropbox's infringing activities with respect to the '215 patent.

RELIEF REQUESTED

WHEREFORE, Plaintiff respectfully requests that the Court:

- A. Declaring that Defendant has infringed the '215 patent;
- B. Awarding damages in an amount to be proven at trial, but in no event less than a reasonable royalty for Defendant's infringement including pre-judgment and post-judgment interest at the maximum rate permitted by law;
- C. Ordering an award of reasonable attorneys' fees and enhanced damages as appropriate against Defendant to Motion Offense as provided by 35 U.S.C. § 285;
- D. Awarding expenses, costs, and disbursements in this action against Defendant, including prejudgment interest; and
- E. All other relief necessary or appropriate.

JURY DEMAND

Pursuant to Federal Rule of Civil Procedure 38(b), Plaintiff hereby demands a trial by jury on all issues so triable.

Dated: July 23, 2021

/s/ Timothy Devlin

Timothy Devlin

Derek Dahlgren (*pro hac vice* to be filed)

Srikant Cheruvu (*pro hac vice* to be filed)

DEVLIN LAW FIRM LLC

1526 Gilpin Avenue

Wilmington, DE 19806

Telephone: (302) 449-9010

Facsimile: (302) 353-4251

tdevlin@devlinlawfirm.com

ddahlgren@devlinlawfirm.com

scheruvu@devlinlawfirm.com

Attorneys for Plaintiff Motion Offense, LLC