

**IN THE UNITED STATES DISTRICT COURT  
FOR THE WESTERN DISTRICT OF TEXAS  
WACO DIVISION**

BUFFALO PATENTS, LLC,

Plaintiff,

v.

COOLPAD GROUP LIMITED and  
YULONG COMPUTER  
TELECOMMUNICATION SCIENTIFIC  
(SHENZHEN) CO. LTD.,

Defendants.

CIVIL ACTION NO. 6:21-cv-1061

ORIGINAL COMPLAINT FOR  
PATENT INFRINGEMENT

**JURY TRIAL DEMANDED**

**ORIGINAL COMPLAINT FOR PATENT INFRINGEMENT**

Plaintiff Buffalo Patents, LLC (“Buffalo Patents” or “Plaintiff”) files this original complaint against Defendants Coolpad Group Limited and Yulong Computer Telecommunication Scientific (Shenzhen) Co. Ltd. (collectively, “Coolpad” or “Defendants”), alleging, based on its own knowledge as to itself and its own actions and based on information and belief as to all other matters, as follows:

**PARTIES**

1. Buffalo Patents is a limited liability company formed under the laws of the State of Texas, with its principal place of business at 1200 Silver Hill Dr., Austin, Texas, 78746.
2. Defendant Coolpad Group Limited is a company duly organized and existing under the laws of the Cayman Islands, with a place of business located at 44/F, Office Tower, Convention Plaza, 1 Harbour Road, Wanchai, Hong Kong SAR, China. Coolpad Group Limited may also be served with process by serving the Texas Secretary of State, 1019 Brazos Street, Austin, Texas 78701, as its agent for service because it engages in business in Texas but has not

designated or maintained a resident agent for service of process in Texas as required by statute. This action arises out of that business.

3. Defendant Yulong Computer Telecommunication Scientific (Shenzhen) Co. Ltd. (“Yulong Shenzhen”) is a company duly organized and existing under the laws of the People’s Republic of China. Yulong Shenzhen has an office at Building B, Boton Science Park Chaguang Road, Xili Town, Nanshan District, Shenzhen China. Yulong Shenzhen may also be served with process by serving the Texas Secretary of State, 1019 Brazos Street, Austin, Texas 78701, as its agent for service because it engages in business in Texas but has not designated or maintained a resident agent for service of process in Texas as required by statute. This action arises out of that business.

4. Yulong Shenzhen is an indirect wholly owned subsidiary of Coolpad Group Limited. It develops and provides integrated solutions for Coolpad smartphone sets, mobile data platform system, and value-added business operations.<sup>1</sup>

5. The Defendants identified in paragraphs 2–4 above (collectively, “Coolpad”) are part of an interrelated group of companies which together comprise one of the world’s largest manufacturers of wireless devices and one of the leading sellers of wireless devices in the United States, including the Coolpad brand. According to its company profile, Coolpad Group Limited “and its subsidiaries (collectively, the ‘Group’) have developed a large number of proprietary technologies and patents in mobile operating systems, radio frequency, protocols and wireless data decomposed transmission technology, etc.”<sup>2</sup>

---

<sup>1</sup> Coolpad Group Limited Annual Report 2020, at 2, <https://doc.irasia.com/listco/hk/coolpad/annual/2020/ar2020.pdf>; <http://www.coolpad.com.hk/eng/about/profile.htm>.

<sup>2</sup> <http://www.coolpad.com.hk/eng/about/profile.htm>.

6. The Coolpad defendants named above and their affiliates are part of the same corporate structure and distribution chain for the making, importing, offering to sell, selling, and using of the accused devices in the United States, including in the State of Texas generally and this judicial district in particular.

7. The Coolpad defendants named above and their affiliates share the same management, common ownership, advertising platforms, facilities, distribution chains and platforms, and accused product lines and products involving related technologies.

8. Thus, the Coolpad defendants named above and their affiliates operate as a unitary business venture and are jointly and severally liable for the acts of patent infringement alleged herein.

#### **JURISDICTION AND VENUE**

9. This is an action for infringement of United States patents arising under 35 U.S.C. §§ 271, 281, and 284–85, among others. This Court has subject matter jurisdiction of the action under 28 U.S.C. § 1331 and § 1338(a).

10. This Court has personal jurisdiction over Coolpad pursuant to due process and/or the Texas Long Arm Statute because, *inter alia*, (i) Coolpad has done and continues to do business in Texas; and (ii) Coolpad has committed and continues to commit acts of patent infringement in the State of Texas, including making, using, offering to sell, and/or selling accused products in Texas, and/or importing accused products into Texas, including by Internet sales and/or sales via retail and wholesale stores, inducing others to commit acts of patent infringement in Texas, and/or committing at least a portion of any other infringements alleged herein in Texas. In addition, or in the alternative, this Court has personal jurisdiction over Coolpad pursuant to Fed. R. Civ. P. 4(k)(2).

11. Venue is proper as to Defendants Coolpad Group Limited and Yulong Shenzhen, both of which are organized under the laws of foreign jurisdictions. 28 U.S.C. § 1391(c)(3) provides that “a defendant not resident in the United States may be sued in any judicial district, and the joinder of such a defendant shall be disregarded in determining where the action may be brought with respect to other defendants.” *See also In re HTC Corp.*, 889 F.3d 1349 (Fed. Cir. 2018).

### **BACKGROUND**

12. The patents-in-suit generally relate to internet and wireless network telephony. They disclose methods and systems for transmitting voice information to an end user in a digital format based on a network protocol (such as Wi-Fi or IEEE 802.11). The patented technology is used in smartphones and other devices for Voice over Wi-Fi calling (VoWi-Fi). The technology allows a user to place a call over private networks, such as WLANs (IEEE 802.11 wireless local area networks), home Wi-Fi networks, and public Wi-Fi hotspots.

13. The technology disclosed by the patents-in-suit was developed by engineers at the Danish company Nextlink.to A/S in the late 1990s. Nextlink began operations in 1999 and its roots originate from “The Danish Sound,” an international industry cluster with a long tradition of technological achievements in acoustics, hearing, and mobile communication based on research and collaboration between businesses and universities.<sup>3</sup> In the early 2000s, Nextlink developed the smallest Bluetooth headset in the world, which was presented at the IBC Bluetooth Congress in Monte Carlo. In 2008, the company changed its name to Invisio

---

<sup>3</sup> *See* INVISIO Annual Report 2018, at 26, <https://invisio.com/media/1358/invisio-communications-annual-report-2018.pdf>; *see also* <https://invisio.com/about/history> (“Denmark has a long tradition of world-leading technology in hearing and acoustics with products from hearing aids to headsets and loudspeakers.”)

Headsets AB and streamlined the business to focus on communication solutions for professional users.<sup>4</sup> The current company, INVISIO, develops advanced communication systems that help professionals in mission critical environments to communicate and work more effectively.<sup>5</sup>

14. The inventions disclosed in the patents-in-suit have been cited during patent prosecution multiple times by leading technology companies in the telecommunications industry, including ADC Telecom (now TE Connectivity), AT&T, Fujitsu, General Instrument Corp. (now Motorola Mobility), GN Group, Huawei, iGo, Koninklijke Philips, NVIDIA, Samsung, Sennheiser, Sony, and Sprint.

### **COUNT I**

#### **DIRECT INFRINGEMENT OF U.S. PATENT NO. 7,187,670**

15. On March 6, 2007, United States Patent No. 7,187,670 (“the ‘670 Patent”) was duly and legally issued by the United States Patent and Trademark Office for an invention entitled “Communications Terminal, a System and a Method for Internet/Network Telephony.”

16. Buffalo Patents is the owner of the ‘670 Patent, with all substantive rights in and to that patent, including the sole and exclusive right to prosecute this action and enforce the ‘670 Patent against infringers, and to collect damages for all relevant times.

17. Coolpad made, had made, used, imported, provided, supplied, distributed, sold, and/or offered for sale products and/or systems including, for example, its Coolpad Legacy family of products that support Voice over Wi-Fi (VoWi-Fi) or Wi-Fi calling (“accused products”):

---

<sup>4</sup> *Id.*

<sup>5</sup> See <https://invisio.com>.

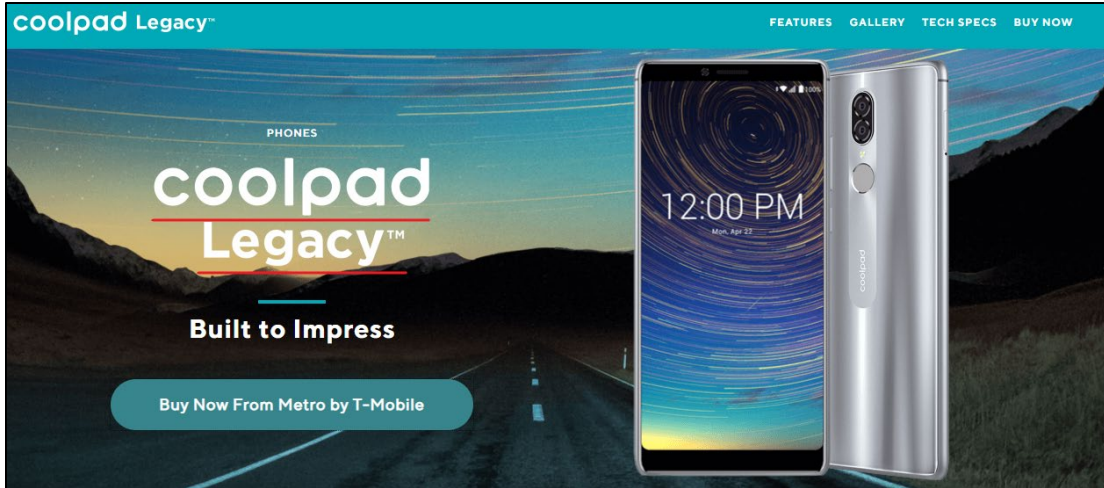

Source: <https://coolpad.us/legacy/>.

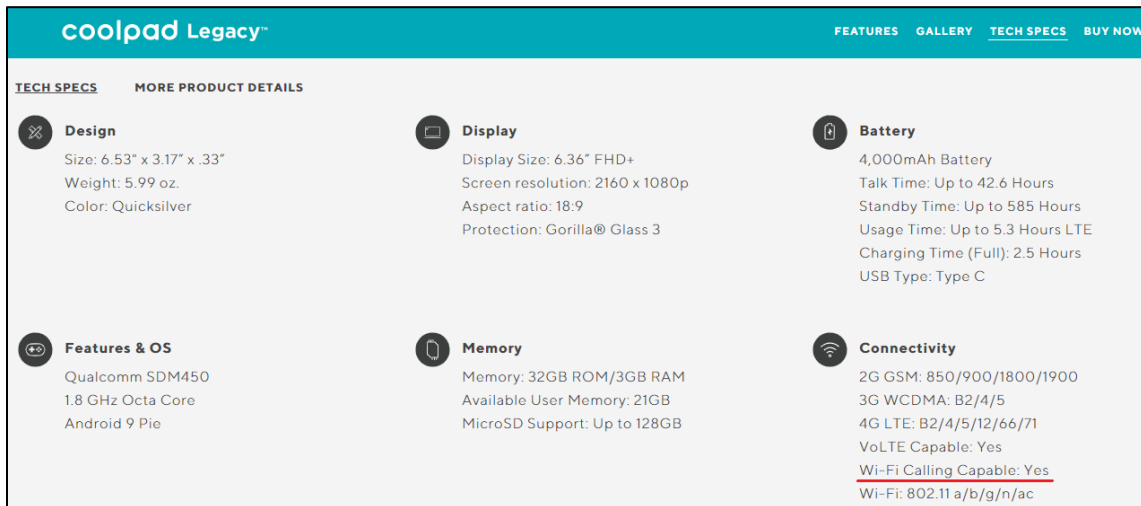

Source: <https://coolpad.us/legacy/>

18. By doing so, Coolpad has directly infringed (literally and/or under the doctrine of equivalents) at least Claim 1 of the '670 Patent. Coolpad's infringement in this regard is ongoing.

19. Coolpad Legacy devices are exemplary accused products.

20. A Coolpad Legacy device is an electronic portable communications terminal for network telephony. It includes audio means for reproducing sound on the basis of a first electrical signal and to record sound resulting in a second electrical signal.

21. For example, a Coolpad Legacy device supports Wi-Fi calling/Voice over Wi-Fi (VoWi-Fi). VoWi-Fi enables a user to make and receive calls over the internet. A Coolpad Legacy device includes a microphone and a speaker (“audio means”) to detect sounds generated by the user and to generate sounds based on voice data, respectively.

22. As an example, when a calling party establishes a call using the VoWi-Fi feature, the sound waves generated by the calling party are converted into analog electrical signals (“second electrical signal”) by the microphone.

23. Further, voice data received at the calling party’s device is processed to generate analog voice signals (“first electrical signal”), which are fed to the speaker to generate or reproduce sound.

The screenshot displays the technical specifications for the Coolpad Legacy smartphone. The page is titled 'coolpad Legacy™' and includes navigation links for 'FEATURES', 'GALLERY', 'TECH SPECS', and 'BUY NOW'. The 'TECH SPECS' section is active, showing details under 'MORE PRODUCT DETAILS'.

Category	Specifications
<b>Design</b>	Size: 6.53" x 3.17" x .33" Weight: 5.99 oz. Color: Quicksilver
<b>Display</b>	Display Size: 6.36" FHD+ Screen resolution: 2160 x 1080p Aspect ratio: 18:9 Protection: Gorilla® Glass 3
<b>Battery</b>	4,000mAh Battery Talk Time: Up to 42.6 Hours Standby Time: Up to 585 Hours Usage Time: Up to 5.3 Hours LTE Charging Time (Full): 2.5 Hours USB Type: Type C
<b>Features &amp; OS</b>	Qualcomm SDM450 1.8 GHz Octa Core Android 9 Pie
<b>Memory</b>	Memory: 32GB ROM/3GB RAM Available User Memory: 21GB MicroSD Support: Up to 128GB
<b>Connectivity</b>	2G GSM: 850/900/1800/1900 3G WCDMA: B2/4/5 4G LTE: B2/4/5/12/66/71 VoLTE Capable: Yes <u>Wi-Fi Calling Capable: Yes</u> Wi-Fi: 802.11 a/b/g/n/ac

Source: <https://coolpad.us/legacy/>

### What is Voice over Wi-Fi?

Voice over Wi-Fi (VoWi-Fi) refers to the use of IEEE 802.11 wireless LANs (WLANs) to transport Voice over IP (VoIP) traffic. The technology has consumer, business and service provider applications. It is used over private WLANs, home Wi-Fi networks and public Wi-Fi hotspots.

Source: <https://ribboncommunications.com/company/get-help/glossary/voice-over-wi-fi>

**Microphone**

The microphone changes the sound waves from your voice into electrical signals that are sent to the audio amplifier of the radio components. A microphone is essentially a speaker that works in reverse. When sound waves from your voice move the membrane, they make tiny electric currents either by moving a coil of wire within a magnet or by compressing the membrane against carbon dust (see [How do microphones work?](#) for details).

Source: <https://electronics.howstuffworks.com/cordless-telephone4.htm>

One common application for CODECs is with Digital Signal Processors (DSPs) in audio electronics devices. CODECs convert sound (using the ADC) to digital signals for a processor to compress and store and for playback, the stored digital data is decompressed and converted to analog signals via the DAC. The analog signal reaches the human ear by converting the analog signal into a transmissible sound via a pulse width modulator and a speaker, for example.

Source: <https://www.analogictips.com/what-is-a-codec/>



Source:

[https://coolpadsupport.zendesk.com/hc/article\\_attachments/360034048814/Coolpad\\_Legacy\\_QS\\_G\\_English\\_Spanish.pdf](https://coolpadsupport.zendesk.com/hc/article_attachments/360034048814/Coolpad_Legacy_QS_G_English_Spanish.pdf) (Page 1)



The dual-purpose nano SIM card / MicroSD card tray resides on the left edge, while the power and volume buttons reside on the right. At the top you'll find a microphone and a 3.5mm headphone jack. The bottom edge plays host to the USB-C port and two speaker grilles: One for the 1W speaker and one for the main microphone. The front-facing camera and earpiece speaker sit within the phone's display header as usual.



**Source:** <https://www.androidauthority.com/coolpad-legacy-review-1001320/>

24. A Coolpad Legacy device includes a converting means converting said second electrical signal into transmission data, representing sound for transmission, in a suitable data format, and to convert received data, representing received sound, in said suitable data format into said first electrical signal.

25. For example, a Coolpad Legacy device supports Wi-Fi calling/Voice over Wi-Fi (VoWi-Fi). VoWi-Fi enables a user to make and receive calls over the internet. A Coolpad Legacy device includes a codec (coder/decoder) (“converting means”) to convert analog voice input into digital data and vice versa.

26. As an example, when a calling party establishes a call using the VoWi-Fi feature, the electrical signal generated by the microphone (“second electrical signal”) is converted into

digital data (“transmission data, representing sound for transmission, in a suitable data format”) with the help of a codec.

27. Further, packetized voice data received at the calling party’s device is processed and converted into digital data. This digital data (“received data, representing received sound, in said suitable data format”) is further fed to the codec to generate an analog voice signal (“first electrical signal”).

**coolpad Legacy™**      FEATURES   GALLERY   **TECH SPECS**   BUY NOW

**TECH SPECS**    MORE PRODUCT DETAILS

- Design**  
Size: 6.53" x 3.17" x .33"  
Weight: 5.99 oz.  
Color: Quicksilver
- Display**  
Display Size: 6.36" FHD+  
Screen resolution: 2160 x 1080p  
Aspect ratio: 18:9  
Protection: Gorilla® Glass 3
- Battery**  
4,000mAh Battery  
Talk Time: Up to 42.6 Hours  
Standby Time: Up to 585 Hours  
Usage Time: Up to 5.3 Hours LTE  
Charging Time (Full): 2.5 Hours  
USB Type: Type C
- Features & OS**  
Qualcomm SDM450  
1.8 GHz Octa Core  
Android 9 Pie
- Memory**  
Memory: 32GB ROM/3GB RAM  
Available User Memory: 21GB  
MicroSD Support: Up to 128GB
- Connectivity**  
2G GSM: 850/900/1800/1900  
3G WCDMA: B2/4/5  
4G LTE: B2/4/5/12/66/71  
VoLTE Capable: Yes  
Wi-Fi Calling Capable: Yes  
Wi-Fi: 802.11 a/b/g/n/ac

Source: <https://coolpad.us/legacy/>

### What is Voice over Wi-Fi?

Voice over Wi-Fi (VoWi-Fi) refers to the use of IEEE 802.11 wireless LANs (WLANs) to transport Voice over IP (VoIP) traffic. The technology has consumer, business and service provider applications. It is used over private WLANs, home Wi-Fi networks and public Wi-Fi hotspots.

Source: <https://ribboncommunications.com/company/get-help/glossary/voice-over-wi-fi>

### 3. Codecs

The quality of voice is a characteristic on digital telephony. Since VoIP and VoWiFi combine digital telephony and networking technologies they also have the quality of voice characteristic. An important element that controls the quality of voice is the compression, and conversion of analog to digital (codec) used on the voice traffic. There are numerous codecs defined for use with voice traffic. The following sections will introduce and give an overview of a few current codecs in use.

Source: [https://www.cse.wustl.edu/~jain/cse574-06/ftp/wireless\\_voip/index.html](https://www.cse.wustl.edu/~jain/cse574-06/ftp/wireless_voip/index.html)

One common application for CODECs is with Digital Signal Processors (DSPs) in audio electronics devices. CODECs convert sound (using the ADC) to digital signals for a processor to compress and store and for playback, the stored digital data is decompressed and converted to analog signals via the DAC. The analog signal reaches the human ear by converting the analog signal into a transmissible sound via a pulse width modulator and a speaker, for example.

**Source:** <https://www.analogictips.com/what-is-a-codec/>

Baseband part in a mobile is comprised of a digital signal processor (DSP) to process forward voice/data signals for transmission and to process reverse voice/data signals received.

This is the core processing part which changes for various air interface standards like GSM, HSPA, LTE and more. It is often named as physical layer or Layer 1 or L1. For Speech/audio, codec is used to compress and decompress the signal to match the data rate to the frame it has to fit in. The baseband or physical layer will add redundant bits to enable error detection as well as error correction. Error detection is obtained with CRC and error correction with forward error correction techniques. Other than this interleaving is done for the data of one burst which helps in spreading the error over the time hence helps receiver de-interleave and decode the frame (consecutively data burst) correctly.

**Source:** <https://insinuator.net/2016/10/a-journey-into-the-depths-of-vowifi-security/>

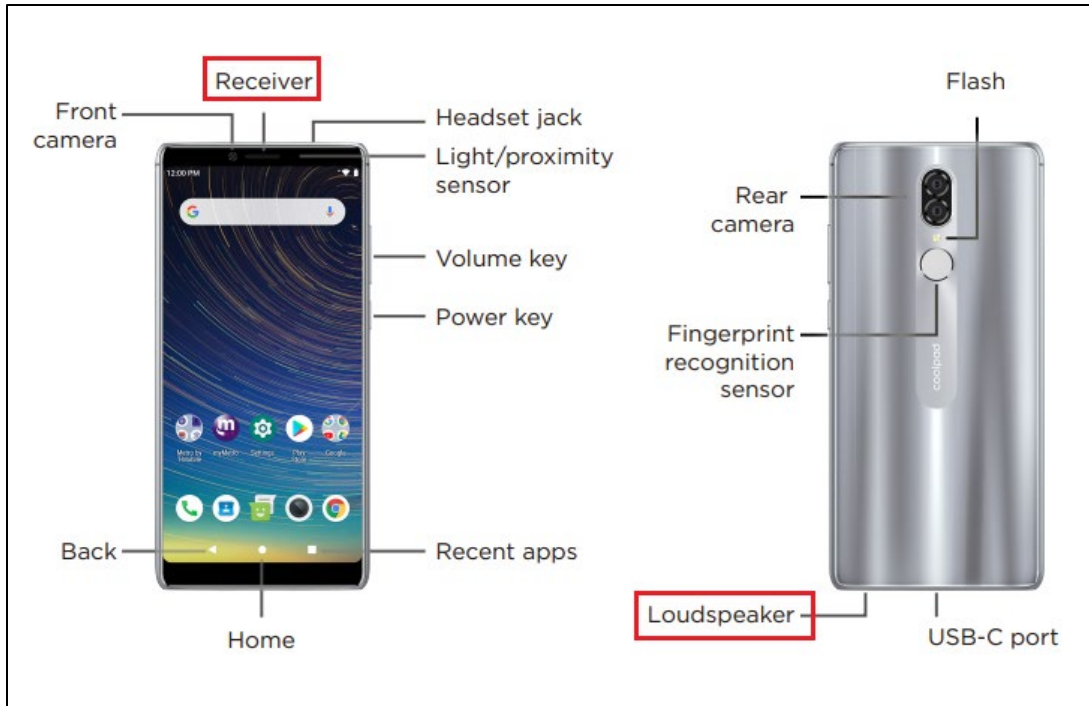

**Source:**

[https://coolpadsupport.zendesk.com/hc/article\\_attachments/360034048814/Coolpad\\_Legacy\\_OS\\_G\\_English\\_Spanish.pdf](https://coolpadsupport.zendesk.com/hc/article_attachments/360034048814/Coolpad_Legacy_OS_G_English_Spanish.pdf) (Page 1)

The dual-purpose nano SIM card / MicroSD card tray resides on the left edge, while the power and volume buttons reside on the right. At the top you'll find a microphone and a 3.5mm headphone jack. The bottom edge plays host to the USB-C port and two speaker grilles: One for the 1W speaker and one for the main microphone. The front-facing camera and earpiece speaker sit within the phone's display header as usual.



**Source:** <https://www.androidauthority.com/coolpad-legacy-review-1001320/>

28. A Coolpad Legacy device includes a protocol means connected to said converting means for handling and controlling communication of said received and transmission data in accordance with a standardized network protocol, thereby embedding and extracting said transmission and received data, respectively, in/from a data packet format according to said standardized network protocol.

29. For example, a Coolpad Legacy device supports Wi-Fi calling/Voice over Wi-Fi (VoWi-Fi). VoWi-Fi enables a user to make and receive calls over the internet.

30. As one example, when a calling party establishes a call using the VoWi-Fi feature, the voice input is converted into digital voice data and the digital voice data is split and encapsulated (“thereby embedding”) into IP (Internet Protocol) packets (“data packet format”) by the device.

31. Further, when voice data is received at the calling party’s device, the data is processed and the IP packets (encapsulated data), including the packetized voice data, are extracted. The IP packets correspond to the IP protocol (“standardized network protocol”). A Coolpad Legacy device includes a processor (“protocol means”) for embedding and extracting the digital data into/from IP packets, respectively.

The screenshot shows the 'TECH SPECS' section of the Coolpad Legacy product page. The page has a teal header with the brand name and navigation links for 'FEATURES', 'GALLERY', 'TECH SPECS', and 'BUY NOW'. Below the header, there are two tabs: 'TECH SPECS' (selected) and 'MORE PRODUCT DETAILS'. The specifications are organized into six columns:

- Design:** Size: 6.53" x 3.17" x .33", Weight: 5.99 oz., Color: Quicksilver
- Display:** Display Size: 6.36" FHD+, Screen resolution: 2160 x 1080p, Aspect ratio: 18:9, Protection: Gorilla® Glass 3
- Battery:** 4,000mAh Battery, Talk Time: Up to 42.6 Hours, Standby Time: Up to 585 Hours, Usage Time: Up to 5.3 Hours LTE, Charging Time (Full): 2.5 Hours, USB Type: Type C
- Features & OS:** Qualcomm SDM450, 1.8 GHz Octa Core, Android 9 Pie
- Memory:** Memory: 32GB ROM/3GB RAM, Available User Memory: 21GB, MicroSD Support: Up to 128GB
- Connectivity:** 2G GSM: 850/900/1800/1900, 3G WCDMA: B2/4/5, 4G LTE: B2/4/5/12/66/71, VoLTE Capable: Yes, Wi-Fi Calling Capable: Yes, Wi-Fi: 802.11 a/b/g/n/ac

Source: <https://coolpad.us/legacy/>

**What is VoWiFi?**

Voice over Wi-Fi (VoWiFi), as the name implies, is delivering voice service via WiFi network. Users can make calls without the need of mobile signal. VoWiFi is a complementary technology to Voice over LTE (VoLTE). Both make use of the IP Multimedia Subsystem (IMS) technology to realize the voice traffic as IP packets.

Source: <https://insinuator.net/2016/10/a-journey-into-the-depths-of-vowifi-security/>

### Transport Layer (Layer 4)

Transport layer adds many information with original data as Transport layer header (Layer 4 header), which are relevant for data processing at the Transport layer.

The Application layer message is encapsulated at the Transport layer. If the protocol used at the Transport Layer is TCP (Transmission Control Protocol), the data packet is known as "TCP Segment". If the protocol used at the Transport layer is UDP (User Datagram Protocol), the data packet is known as "UDP Datagram".

### Network Layer (Layer 3)

Network layer adds additional data as header, which are relevant for processing data at Network layer.

The data packet created at the Network layer by Internet Protocol (IPv4 or IPv6), which encapsulates its upper layer Transport layer segment/datagram, is known as "IP Datagram".

Source: <https://www.omniseccu.com/tcpip/tcpip-encapsulation-decapsulation.php>

### Datalink Layer (Layer 2)

Receiver opens the Datalink layer header and trailer (Layer 2 header and trailer), uses the values at Datalink header and trailer for processing data at the Datalink layer.

Receiver then collects the Network layer packet (IPv4 or IPv6 Datagram), and it is transferred to Network layer for further processing.

Source: <https://www.omniseccu.com/tcpip/tcpip-encapsulation-decapsulation.php>

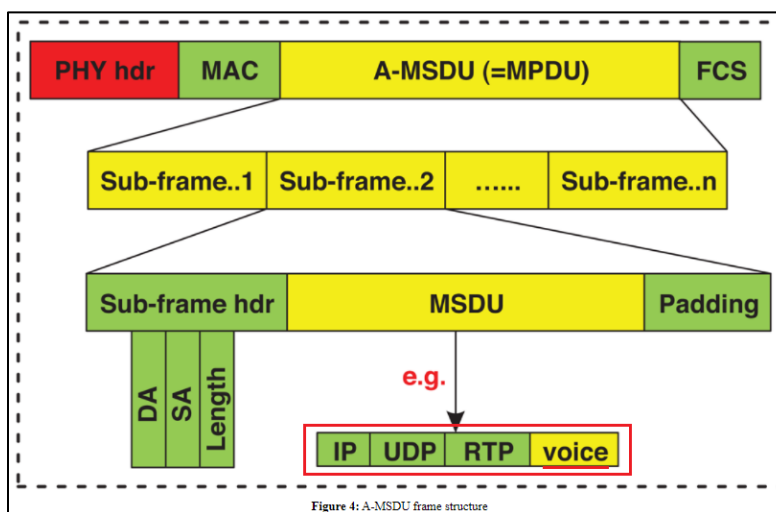

Figure 4: A-MSDU frame structure

Source: <https://www.techscience.com/cmc/v66n2/40658/html>

32. A Coolpad Legacy device includes a wireless near field communications means connected to said protocol means for receiving/sending said received and transmission data in said first data packet format from/to said protocol means. The near field communications means embeds said transmission data in said first data packet format received from said protocol means

in a wireless second data format and extracts said received data in said first data packet format from said wireless second data format.

33. For example, a Coolpad Legacy device supports Wi-Fi calling/Voice over Wi-Fi (VoWi-Fi). VoWi-Fi enables a user to make and receive calls over the internet. As one example, when a calling party establishes a call using the VoWi-Fi feature, the voice input is processed and encapsulated into IP packets (“first data packet format”) by the device. Further, when voice data is received at the calling party’s device, the data is processed and the encapsulated IP packets, including the packetized voice data, are extracted. A Coolpad Legacy device includes a processor (“protocol means”) for embedding and extracting the digital data into/from IP packets, respectively.

34. The IP packets (“in said first data packet format”) received from the protocol means are then embedded into PPDU (PLCP (Physical Layer Convergence Protocol) protocol Data Unit) frames by adding appropriate headers, such as Physical layer and MAC layer headers. The Coolpad Legacy device includes a Wi-Fi chipset (“wireless near field communication means”) for embedding the IP packets into the IEEE 802.11 frame format (PPDUs) (“wireless second data format”).

35. When the calling party receives the voice data (PPDUs) from the wireless network, the embedded IP packets are extracted from these PPDU frames by the removal of appropriate headers. The received PPDU frames correspond to the IEEE 802.11 protocol. The extracted IP packets, including the packetized voice data, are then sent to the protocol means for further processing. The Wi-Fi chipset (“wireless near field communication means”) extracts the IP packets from the received PPDUs and sends them to the protocol means.



**coolpad Legacy™** FEATURES GALLERY TECH SPECS BUY NOW

**TECH SPECS** MORE PRODUCT DETAILS

<p><b>Design</b></p> <p>Size: 6.53" x 3.17" x .33" Weight: 5.99 oz. Color: Quicksilver</p>	<p><b>Display</b></p> <p>Display Size: 6.36" FHD+ Screen resolution: 2160 x 1080p Aspect ratio: 18:9 Protection: Gorilla® Glass 3</p>	<p><b>Battery</b></p> <p>4,000mAh Battery Talk Time: Up to 42.6 Hours Standby Time: Up to 585 Hours Usage Time: Up to 5.3 Hours LTE Charging Time (Full): 2.5 Hours USB Type: Type C</p>
<p><b>Features &amp; OS</b></p> <p>Qualcomm SDM450 1.8 GHz Octa Core Android 9 Pie</p>	<p><b>Memory</b></p> <p>Memory: 32GB ROM/3GB RAM Available User Memory: 21GB MicroSD Support: Up to 128GB</p>	<p><b>Connectivity</b></p> <p>2G GSM: 850/900/1800/1900 3G WCDMA: B2/4/5 4G LTE: B2/4/5/12/66/71 VoLTE Capable: Yes <u>Wi-Fi Calling Capable: Yes</u> Wi-Fi: 802.11 a/b/g/n/ac</p>

Source: <https://coolpad.us/legacy/>

**What is VoWiFi?**

Voice over Wi-Fi (VoWiFi), as the name implies, is delivering voice service via WiFi network. Users can make calls without the need of mobile signal. VoWiFi is a complementary technology to Voice over LTE (VoLTE). Both make use of the IP Multimedia Subsystem (IMS) technology to realize the voice traffic as IP packets.

Source: <https://insinuator.net/2016/10/a-journey-into-the-depths-of-vowifi-security/>

**Datalink layer (Layer 2)**

The data packet generated at **Network layer** is then placed inside Datalink layer header and trailer (Layer 2 header and trailer). Values inside Datalink layer header and trailer are relevant for processing data at **Datalink layer**.

The data packet at the **Datalink layer**, which encapsulates and may subdivide the **IP Datagram**, is known as a "**Frame**" (generally **Ethernet Frame**).

The most important values at Datalink layer header (Layer 2 header) are source and destination **MAC addresses (Layer 2 addresses)**. Following image represents data packet generated at **Datalink layer**.

Source: <https://www.omniseccu.com/tcpip/tcpip-encapsulation-decapsulation.php>

**Datalink Layer (Layer 2)**

Receiver opens the Datalink layer header and trailer (Layer 2 header and trailer), uses the values at **Datalink header and trailer** for processing data at the **Datalink layer**.

Receiver then collects the Network layer packet (IPv4 or IPv6 Datagram), and it is transferred to **Network layer** for further processing.

Source: <https://www.omniseccu.com/tcpip/tcpip-encapsulation-decapsulation.php>

**physical layer (PHY) protocol data unit (PPDU):** The unit of data exchanged between two peer PHY entities to provide the PHY data service.

Source: <https://ieeexplore.ieee.org/document/7786995> (Page 138)

- When the Network layer (layer 3) sends data to the Data-Link layer, that data is handed off to the LLC and becomes known as the MAC Service Data Unit (MSDU).
- The payload of a 802.11 data frame is the layer 3-7 information known as the MSDU.
- A simple definition of the MSDU is that it is the data payload that contains the IP packet plus some LLC data.

Source: <https://dot11ap.wordpress.com/msdu-and-mpdu/>

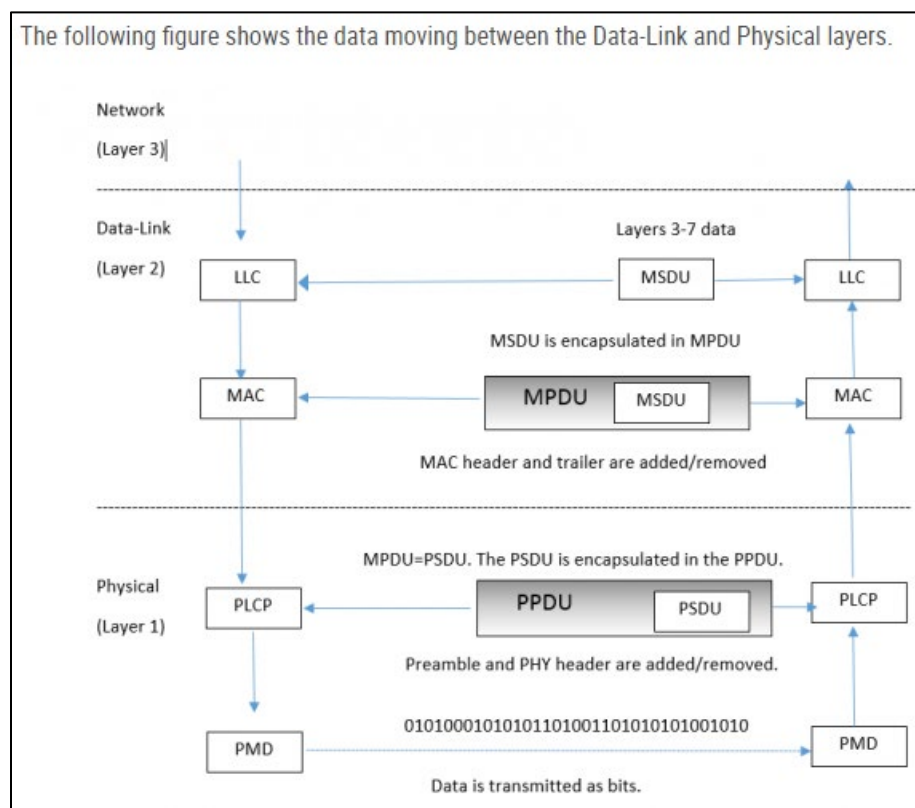

Source: <https://www.cwnp.com/802.11-mac-series-ndash-basics-mac-architecture-ndash-part-1-3/>

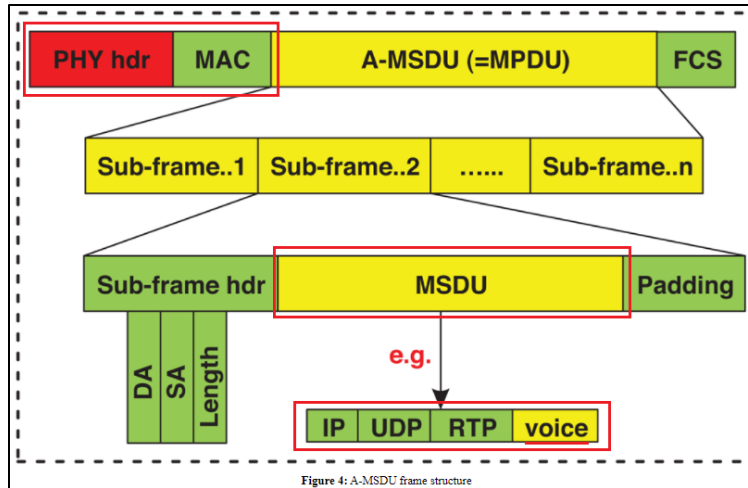

Source: <https://www.techscience.com/cmc/v66n2/40658/html>

36. The wireless near field communications means performs wireless near field communication of said received data or said transmission data embedded in said wireless second data format with a connecting unit communicating in said wireless second, data format and to establish a connection to a network according to said standardized network protocol, whereby the resulting data exchanged between the wireless near field communication means and the connecting unit consist of packets in said first data packet format embedded in said wireless second data format.

37. For example, a Coolpad Legacy device supports Wi-Fi calling/Voice over Wi-Fi (VoWi-Fi). VoWi-Fi enables a user to make and receive calls over the internet. As one example, when a calling party establishes a call using the VoWi-Fi feature, the calling party's device embeds the digital voice data into IP packets. These IP packets ("said first data packet format") are then embedded into PPDU frames by adding appropriate headers, such as Physical layer and MAC layer headers. The Coolpad Legacy device includes a Wi-Fi chipset ("wireless near field communication means") for embedding the IP packets into the IEEE 802.11 frame format (PPDUs) ("wireless second data format").

38. The Wi-Fi chipset (“wireless near field communication means”) of the device transmits the PPDU (“transmission data embedded in wireless second data format”) to the 802.11 router/access point (“connecting unit”) using corresponding wireless communication antennas. The Wi-Fi chipset of the device also receives PPDU (“received data”) from the 802.11 router/access point (“connecting unit”) using corresponding wireless communication antennas. These PPDU correspond to IEEE 802.11 frame format (“wireless second data format”) and include the embedded IP (“first data packet format”) packets with packetized voice data.

39. Further, the 802.11 access points are connected to the internet according to the Internet Protocol (“standardized network protocol”).

TECH SPECS	MORE PRODUCT DETAILS	
<p><b>Design</b></p> <p>Size: 6.53" x 3.17" x .33" Weight: 5.99 oz. Color: Quicksilver</p>	<p><b>Display</b></p> <p>Display Size: 6.36" FHD+ Screen resolution: 2160 x 1080p Aspect ratio: 18:9 Protection: Gorilla® Glass 3</p>	<p><b>Battery</b></p> <p>4,000mAh Battery Talk Time: Up to 42.6 Hours Standby Time: Up to 585 Hours Usage Time: Up to 5.3 Hours LTE Charging Time (Full): 2.5 Hours USB Type: Type C</p>
<p><b>Features &amp; OS</b></p> <p>Qualcomm SDM450 1.8 GHz Octa Core Android 9 Pie</p>	<p><b>Memory</b></p> <p>Memory: 32GB ROM/3GB RAM Available User Memory: 21GB MicroSD Support: Up to 128GB</p>	<p><b>Connectivity</b></p> <p>2G GSM: 850/900/1800/1900 3G WCDMA: B2/4/5 4G LTE: B2/4/5/12/66/71 VoLTE Capable: Yes <u>Wi-Fi Calling Capable: Yes</u> Wi-Fi: 802.11 a/b/g/n/ac</p>

Source: <https://coolpad.us/legacy/>

**What is VoWiFi?**

Voice over Wi-Fi (VoWiFi), as the name implies, is delivering voice service via Wi-Fi network. Users can make calls without the need of mobile signal. VoWiFi is a complementary technology to Voice over LTE (VoLTE). Both make use of the IP Multimedia Subsystem (IMS) technology to realize the voice traffic as IP packets.

Source: <https://insinuator.net/2016/10/a-journey-into-the-depths-of-vowifi-security/>

### Datalink layer (Layer 2)

The data packet generated at **Network layer** is then placed inside **Datalink layer header and trailer (Layer 2 header and trailer)**. Values inside Datalink layer header and trailer are relevant for processing data at **Datalink layer**.

The data packet at the **Datalink layer**, which encapsulates and may subdivide the **IP Datagram**, is known as a "**Frame**" (generally **Ethernet Frame**).

The most important values at Datalink layer header (Layer 2 header) are source and destination **MAC addresses (Layer 2 addresses)**. Following image represents data packet generated at **Datalink layer**.

Source: <https://www.omniseccu.com/tcpip/tcpip-encapsulation-decapsulation.php>

### Datalink Layer (Layer 2)

Receiver opens the **Datalink layer header and trailer (Layer 2 header and trailer)**, uses the values at **Datalink header and trailer** for processing data at the **Datalink layer**.

Receiver then collects the Network layer packet (IPv4 or IPv6 Datagram), and it is transferred to **Network layer** for further processing.

Source: <https://www.omniseccu.com/tcpip/tcpip-encapsulation-decapsulation.php>

**physical layer (PHY) protocol data unit (PPDU):** The unit of data exchanged between two peer PHY entities to provide the PHY data service.

Source: <https://ieeexplore.ieee.org/document/7786995> (Page 138)

- When the Network layer (layer 3) sends data to the Data-Link layer, that data is handed off to the LLC and becomes known as the MAC Service Data Unit (MSDU).
- The payload of a 802.11 data frame is the layer 3-7 information known as the MSDU.
- A simple definition of the MSDU is that it is the data payload that contains the IP packet plus some LLC data.

Source: <https://dot11ap.wordpress.com/msdu-and-mpdu/>

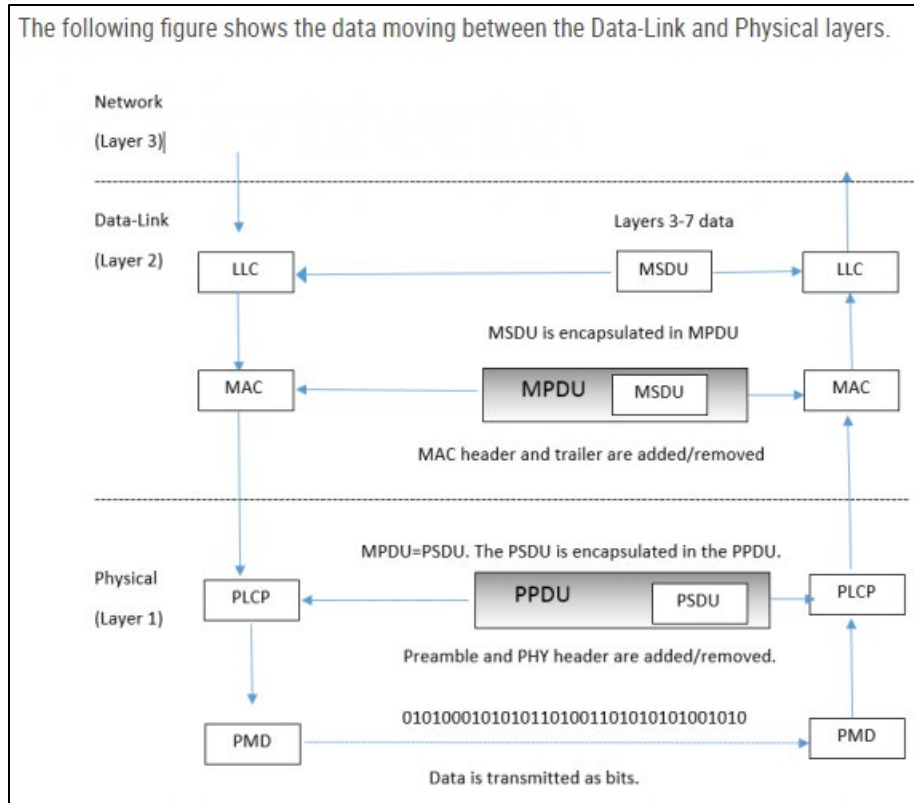

Source: <https://www.cwnp.com/802.11-mac-series-ndash-basics-mac-architecture-ndash-part-1-3/>

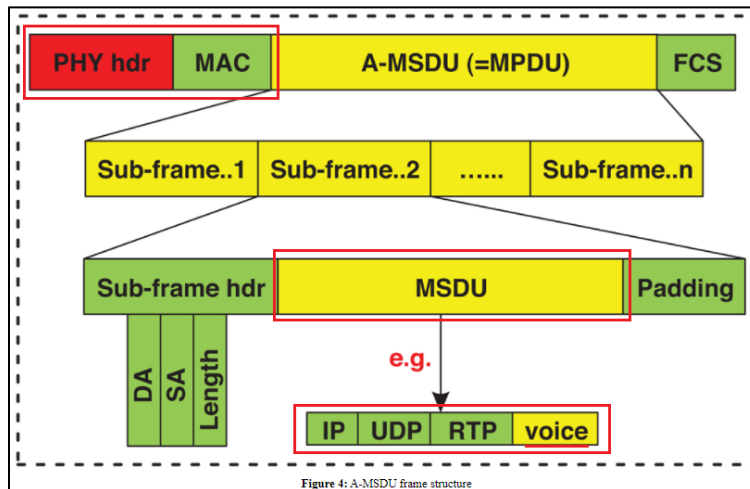

Source: <https://www.techscience.com/cmc/v66n2/40658/html>

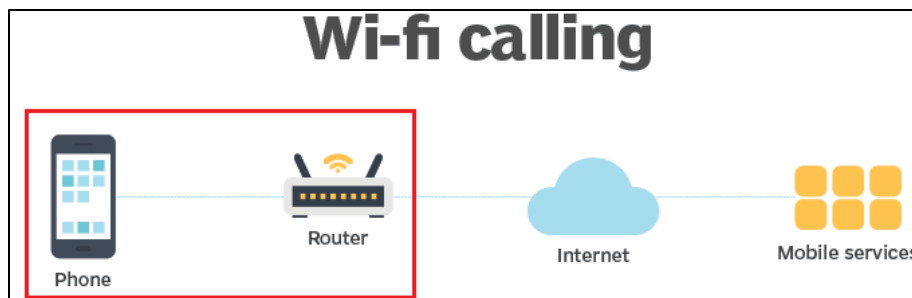

Source: <https://whatis.techtarget.com/definition/Wi-Fi-calling>

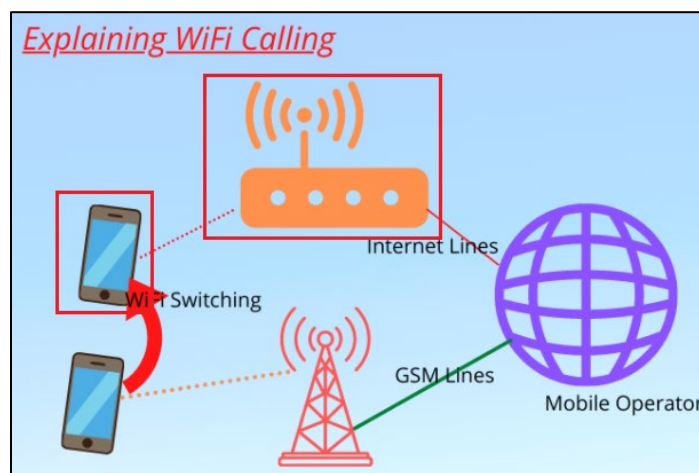

Source: <https://www.cspprotocol.com/what-is-wifi-calling/>

40. Coolpad has had knowledge of the '670 Patent at least as of the date when it was notified of the filing of this action.

41. Buffalo Patents has been damaged as a result of the infringing conduct by Coolpad alleged above. Thus, Coolpad is liable to Buffalo Patents in an amount that adequately compensates it for such infringements, which, by law, cannot be less than a reasonable royalty, together with interest and costs as fixed by this Court under 35 U.S.C. § 284.

42. Buffalo Patents has neither made nor sold unmarked articles that practice the '670 Patent, and is entitled to collect pre-filing damages for the full period allowed by law for infringement of the '670 Patent.

## COUNT II

### DIRECT INFRINGEMENT OF U.S. PATENT NO. 7,408,915

43. On August 5, 2008, United States Patent No. 7,408,915 (“the ’915 Patent”) was duly and legally issued by the United States Patent and Trademark Office for an invention entitled “Communications Terminal, a System and a Method for Internet/Network Telephony.”

44. Buffalo Patents is the owner of the ’915 Patent, with all substantive rights in and to that patent, including the sole and exclusive right to prosecute this action and enforce the ’915 Patent against infringers, and to collect damages for all relevant times.

45. Coolpad made, had made, used, imported, provided, supplied, distributed, sold, and/or offered for sale products and/or systems including, for example, its Coolpad Legacy family of products that support Voice over Wi-Fi (VoWi-Fi) or Wi-Fi calling (“accused products”):

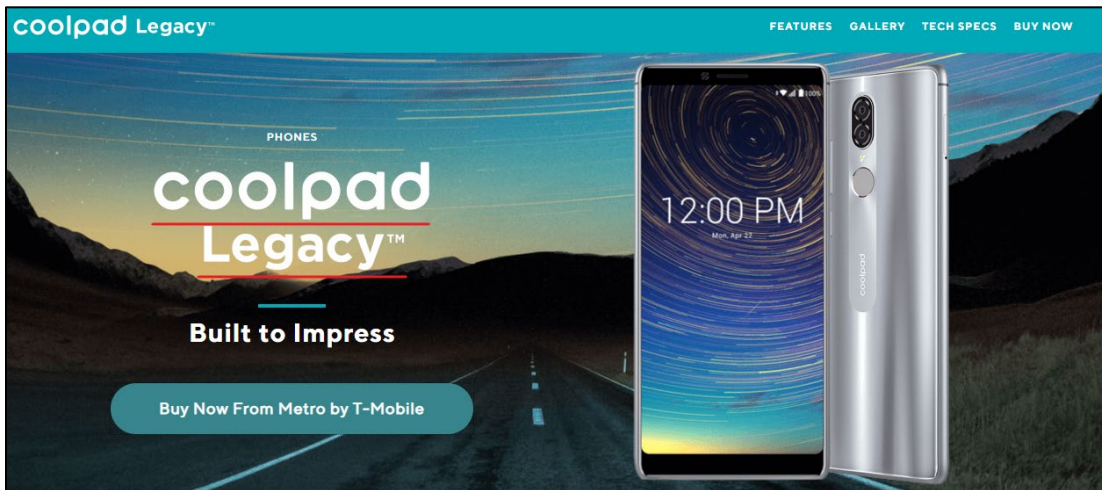

Source: <https://coolpad.us/legacy/>.



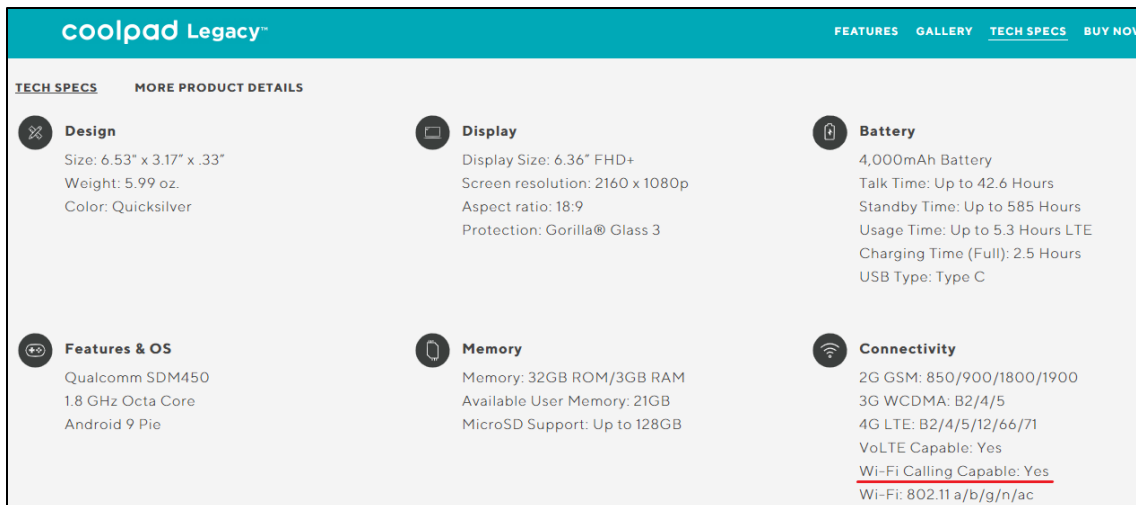

Source: <https://coolpad.us/legacy/>

46. By doing so, Coolpad has directly infringed (literally and/or under the doctrine of equivalents) at least Claim 29 of the '915 Patent. Coolpad's infringement in this regard is ongoing.

47. Coolpad Legacy devices are exemplary accused products.

48. Coolpad has infringed the '915 Patent by using the accused products and thereby practicing a method for network telephony comprising the step of reproducing sound on the basis of a first electrical signal and recording sound resulting in a second electrical signal, by audio means.

49. For example, a Coolpad Legacy device supports Wi-Fi calling/Voice over Wi-Fi (VoWi-Fi). VoWi-Fi enables a user to make and receive calls over the internet. A Coolpad Legacy device includes a microphone and a speaker ("audio means") to detect sounds generated by the user and to generate sounds based on voice data, respectively.

50. As one example, when a calling party establishes a call using the VoWi-Fi feature, the sound waves generated by the calling party are converted into analog electrical signals ("second electrical signal") by the microphone.

51. Further, voice data received at the calling party's device is processed to generate analog voice signals ("first electrical signal"), which are fed to the speaker to generate or reproduce sound.

The screenshot shows the 'coolpad Legacy' product page with the 'TECH SPECS' tab selected. The specifications are organized into six categories:

- Design:** Size: 6.53" x 3.17" x .33", Weight: 5.99 oz., Color: Quicksilver
- Display:** Display Size: 6.36" FHD+, Screen resolution: 2160 x 1080p, Aspect ratio: 18:9, Protection: Gorilla® Glass 3
- Battery:** 4,000mAh Battery, Talk Time: Up to 42.6 Hours, Standby Time: Up to 585 Hours, Usage Time: Up to 5.3 Hours LTE, Charging Time (Full): 2.5 Hours, USB Type: Type C
- Features & OS:** Qualcomm SDM450, 1.8 GHz Octa Core, Android 9 Pie
- Memory:** Memory: 32GB ROM/3GB RAM, Available User Memory: 21GB, MicroSD Support: Up to 128GB
- Connectivity:** 2G GSM: 850/900/1800/1900, 3G WCDMA: B2/4/5, 4G LTE: B2/4/5/12/66/71, VoLTE Capable: Yes, Wi-Fi Calling Capable: Yes, Wi-Fi: 802.11 a/b/g/n/ac

Source: <https://coolpad.us/legacy/>

The screenshot shows a document titled 'Wireless Settings' with the following content:

### Wireless Settings

#### Connecting to a Wi-Fi Network

1. On the Home screen, swipe up and then tap to enter the Settings screen. Then, choose **Network & internet** > **Wi-Fi** to turn Wi-Fi on/off.
2. Drag the slider to On enabling your phone to scan for available Wi-Fi networks.
3. Tap the name of a desired network to connect, entering the password if necessary.

Note: Previously connected and saved networks will be automatically joined. A user can join a network and forget it, removing it from the known networks list.

#### Wi-Fi Calling

Wi-Fi Calling allows you to make and receive phone calls and messages over a Wi-Fi connection.

Source:

[https://coolpadsupport.zendesk.com/hc/article\\_attachments/360034048814/Coolpad\\_Legacy\\_QSG\\_English\\_Spanish.pdf](https://coolpadsupport.zendesk.com/hc/article_attachments/360034048814/Coolpad_Legacy_QSG_English_Spanish.pdf) (Page 1)

### What is Voice over Wi-Fi?

Voice over Wi-Fi (VoWi-Fi) refers to the use of IEEE 802.11 wireless LANs (WLANs) to transport Voice over IP (VoIP) traffic. The technology has consumer, business and service provider applications. It is used over private WLANs, home Wi-Fi networks and public Wi-Fi hotspots.

Source: <https://ribboncommunications.com/company/get-help/glossary/voice-over-wi-fi>

### Microphone

The microphone changes the sound waves from your voice into electrical signals that are sent to the audio amplifier of the radio components. A microphone is essentially a speaker that works in reverse. When sound waves from your voice move the membrane, they make tiny electric currents either by moving a coil of wire within a magnet or by compressing the membrane against carbon dust (see [How do microphones work?](#) for details).

Source: <https://electronics.howstuffworks.com/cordless-telephone4.htm>

One common application for CODECs is with Digital Signal Processors (DSPs) in audio electronics devices. CODECs convert sound (using the ADC) to digital signals for a processor to compress and store and for playback, the stored digital data is decompressed and converted to analog signals via the DAC. The analog signal reaches the human ear by converting the analog signal into a transmissible sound via a pulse width modulator and a speaker, for example.

Source: <https://www.analogictips.com/what-is-a-codec/>

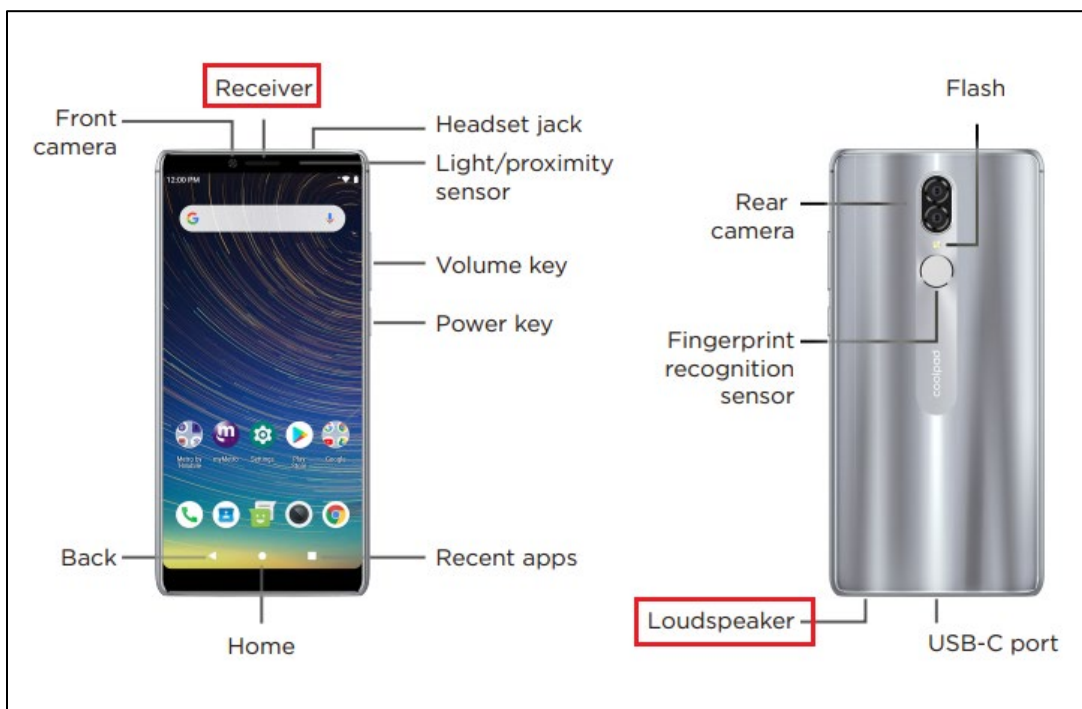

Source:

[https://coolpadsupport.zendesk.com/hc/article\\_attachments/360034048814/Coolpad\\_Legacy\\_QS\\_G\\_English\\_Spanish.pdf](https://coolpadsupport.zendesk.com/hc/article_attachments/360034048814/Coolpad_Legacy_QS_G_English_Spanish.pdf) (Page 1)

The dual-purpose nano SIM card / MicroSD card tray resides on the left edge, while the power and volume buttons reside on the right. At the top you'll find a microphone and a 3.5mm headphone jack. The bottom edge plays host to the USB-C port and two speaker grilles: One for the 1W speaker and one for the main microphone. The front-facing camera and earpiece speaker sit within the phone's display header as usual.



**Source:** <https://www.androidauthority.com/coolpad-legacy-review-1001320/>

52. The method practiced using the accused products further comprises the step of converting said second electrical signal into transmission data, representing sound for transmission, in a suitable data format, and converting received data, representing received sound, in said suitable data format into said first electrical signal, by converting means.

53. For example, a Coolpad Legacy device supports Wi-Fi calling/Voice over Wi-Fi (VoWi-Fi). VoWi-Fi enables a user to make and receive calls over the internet. A Coolpad Legacy device includes a codec (coder/decoder) (“converting means”) to convert analog voice input into digital data and vice versa.

54. As one example, when a calling party establishes a call using the VoWi-Fi feature, the electrical signal generated by the microphone (“second electrical signal”) is

converted into digital data (“transmission data, representing sound for transmission, in a suitable data format”) with the help of a codec.

55. Further, packetized voice data received at the calling party’s device is processed and converted into digital data. This digital data (“representing received sound, in said suitable data format”) is further fed to the codec to generate an analog voice signal (“first electrical signal”).

**coolpad Legacy™**      FEATURES    GALLERY    TECH SPECS    BUY NOW

**TECH SPECS**    MORE PRODUCT DETAILS

- Design**
  - Size: 6.53" x 3.17" x .33"
  - Weight: 5.99 oz.
  - Color: Quicksilver
- Display**
  - Display Size: 6.36" FHD+
  - Screen resolution: 2160 x 1080p
  - Aspect ratio: 18:9
  - Protection: Gorilla® Glass 3
- Battery**
  - 4,000mAh Battery
  - Talk Time: Up to 42.6 Hours
  - Standby Time: Up to 585 Hours
  - Usage Time: Up to 5.3 Hours LTE
  - Charging Time (Full): 2.5 Hours
  - USB Type: Type C
- Features & OS**
  - Qualcomm SDM450
  - 1.8 GHz Octa Core
  - Android 9 Pie
- Memory**
  - Memory: 32GB ROM/3GB RAM
  - Available User Memory: 21GB
  - MicroSD Support: Up to 128GB
- Connectivity**
  - 2G GSM: 850/900/1800/1900
  - 3G WCDMA: B2/4/5
  - 4G LTE: B2/4/5/12/66/71
  - VoLTE Capable: Yes
  - Wi-Fi Calling Capable: Yes
  - Wi-Fi: 802.11 a/b/g/n/ac

Source: <https://coolpad.us/legacy/>

## What is Voice over Wi-Fi?

Voice over Wi-Fi (VoWi-Fi) refers to the use of IEEE 802.11 wireless LANs (WLANs) to transport Voice over IP (VoIP) traffic. The technology has consumer, business and service provider applications. It is used over private WLANs, home Wi-Fi networks and public Wi-Fi hotspots.

Source: <https://ribboncommunications.com/company/get-help/glossary/voice-over-wi-fi>

## 3. Codecs

The quality of voice is a characteristic on digital telephony. Since VoIP and VoWiFi combine digital telephony and networking technologies they also have the quality of voice characteristic. An important element that controls the quality of voice is the compression, and conversion of analog to digital (codec) used on the voice traffic. There are numerous codecs defined for use with voice traffic. The following sections will introduce and give an overview of a few current codecs in use.

Source: [https://www.cse.wustl.edu/~jain/cse574-06/ftp/wireless\\_voip/index.html](https://www.cse.wustl.edu/~jain/cse574-06/ftp/wireless_voip/index.html)

One common application for CODECs is with Digital Signal Processors (DSPs) in audio electronics devices. CODECs convert sound (using the ADC) to digital signals for a processor to compress and store and for playback, the stored digital data is decompressed and converted to analog signals via the DAC. The analog signal reaches the human ear by converting the analog signal into a transmissible sound via a pulse width modulator and a speaker, for example.

**Source:** <https://www.analogictips.com/what-is-a-codec/>

Baseband part in a mobile is comprised of a digital signal processor (DSP) to process forward voice/data signals for transmission and to process reverse voice/data signals received.

This is the core processing part which changes for various air interface standards like GSM, HSPA, LTE and more. It is often named as physical layer or Layer 1 or L1. For Speech/audio, codec is used to compress and decompress the signal to match the data rate to the frame it has to fit in. The baseband or physical layer will add redundant bits to enable error detection as well as error correction. Error detection is obtained with CRC and error correction with forward error correction techniques. Other than this interleaving is done for the data of one burst which helps in spreading the error over the time hence helps receiver de-interleave and decode the frame (consecutively data burst) correctly.

**Source:** <https://insinuator.net/2016/10/a-journey-into-the-depths-of-vowifi-security/>

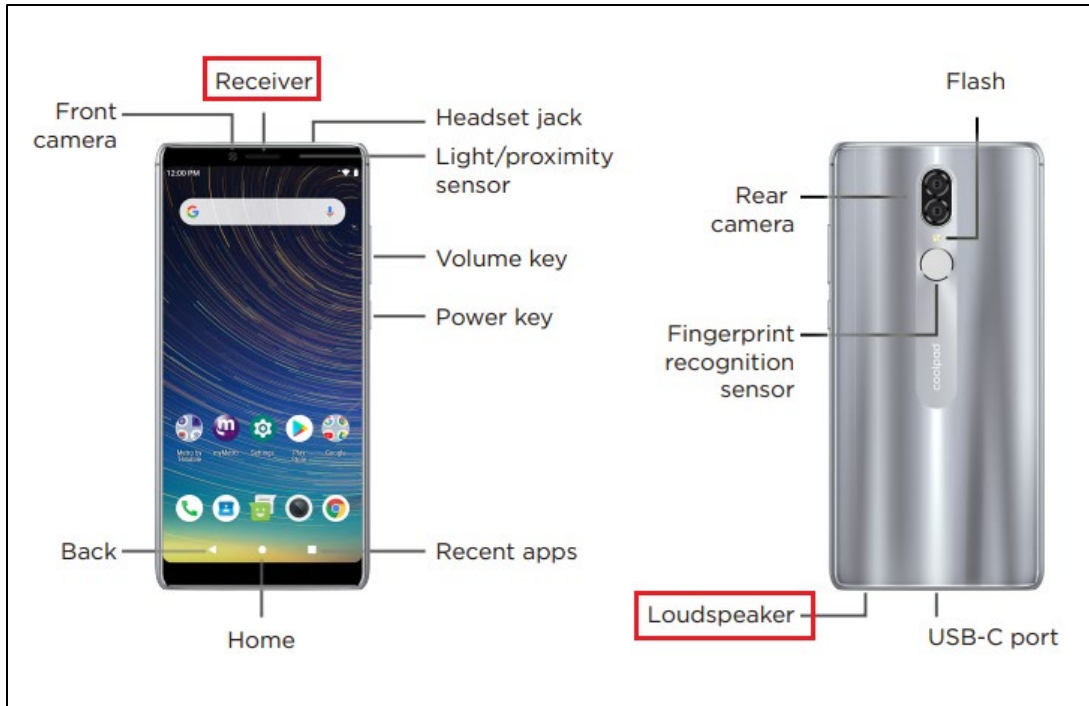

**Source:**

[https://coolpadsupport.zendesk.com/hc/article\\_attachments/360034048814/Coolpad\\_Legacy\\_OS\\_G\\_English\\_Spanish.pdf](https://coolpadsupport.zendesk.com/hc/article_attachments/360034048814/Coolpad_Legacy_OS_G_English_Spanish.pdf) (Page 1)

The dual-purpose nano SIM card / MicroSD card tray resides on the left edge, while the power and volume buttons reside on the right. At the top you'll find a microphone and a 3.5mm headphone jack. The bottom edge plays host to the USB-C port and two speaker grilles: One for the 1W speaker and one for the main microphone. The front-facing camera and earpiece speaker sit within the phone's display header as usual.



**Source:** <https://www.androidauthority.com/coolpad-legacy-review-1001320/>

56. The method practiced using the accused products further comprises the step of handling/controlling communication of said received and transmission data in accordance with a standardized network protocol and embedding and extracting said transmission and received data, respectively, in/from a data packet format according to said standardized network protocol, by protocol means.

57. For example, a Coolpad Legacy device supports Wi-Fi calling/Voice over Wi-Fi (VoWi-Fi). VoWi-Fi enables a user to make and receive calls over the internet.

58. As one example, when a calling party establishes a call using the VoWi-Fi feature, the voice input is converted into digital voice data and the digital voice data is split and encapsulated (“embedding”) into IP (Internet Protocol) packets (“data packet format”) by the device.



59. Further, when digital voice data is received at the calling party's device, the digital voice data is processed and the IP packets (encapsulated data), including the packetized voice data, are extracted. The IP packets correspond to the IP protocol ("standardized network protocol"). A Coolpad Legacy device includes a processor ("protocol means") for embedding and extracting the digital data into/from IP packets, respectively.

The screenshot displays the 'TECH SPECS' section for the Coolpad Legacy smartphone. The page is organized into a grid of six categories, each with an icon and a list of specifications:

- Design:** Size: 6.53" x 3.17" x .33", Weight: 5.99 oz., Color: Quicksilver
- Display:** Display Size: 6.36" FHD+, Screen resolution: 2160 x 1080p, Aspect ratio: 18:9, Protection: Gorilla® Glass 3
- Battery:** 4,000mAh Battery, Talk Time: Up to 42.6 Hours, Standby Time: Up to 585 Hours, Usage Time: Up to 5.3 Hours LTE, Charging Time (Full): 2.5 Hours, USB Type: Type C
- Features & OS:** Qualcomm SDM450, 1.8 GHz Octa Core, Android 9 Pie
- Memory:** Memory: 32GB ROM/3GB RAM, Available User Memory: 21GB, MicroSD Support: Up to 128GB
- Connectivity:** 2G GSM: 850/900/1800/1900, 3G WCDMA: B2/4/5, 4G LTE: B2/4/5/12/66/71, VoLTE Capable: Yes, Wi-Fi Calling Capable: Yes, Wi-Fi: 802.11 a/b/g/n/ac

Source: <https://coolpad.us/legacy/>

The screenshot shows a document titled "What is VoWiFi?". The text explains that Voice over Wi-Fi (VoWiFi) is a technology that delivers voice service via a Wi-Fi network, allowing users to make calls without mobile signal. It is described as a complementary technology to Voice over LTE (VoLTE). Both technologies utilize IP Multimedia Subsystem (IMS) technology to convert voice traffic into IP packets.

Source: <https://insinuator.net/2016/10/a-journey-into-the-depths-of-vowifi-security/>

**Transport Layer (Layer 4)**

Transport layer adds many information with original data as Transport layer header (Layer 4 header), which are relevant for data processing at the Transport layer.

The Application layer message is encapsulated at the Transport layer. If the protocol used at the Transport Layer is TCP (Transmission Control Protocol), the data packet is known as "TCP Segment". If the protocol used at the Transport layer is UDP (User Datagram Protocol), the data packet is known as "UDP Datagram".

**Network Layer (Layer 3)**

Network layer adds additional data as header, which are relevant for processing data at Network layer.

The data packet created at the Network layer by Internet Protocol (IPv4 or IPv6), which encapsulates its upper layer Transport layer segment/datagram, is known as "IP Datagram".

Source: <https://www.omniseccu.com/tcpip/tcpip-encapsulation-decapsulation.php>

**Datalink Layer (Layer 2)**

Receiver opens the Datalink layer header and trailer (Layer 2 header and trailer), uses the values at Datalink header and trailer for processing data at the Datalink layer.

Receiver then collects the Network layer packet (IPv4 or IPv6 Datagram), and it is transferred to Network layer for further processing.

Source: <https://www.omniseccu.com/tcpip/tcpip-encapsulation-decapsulation.php>

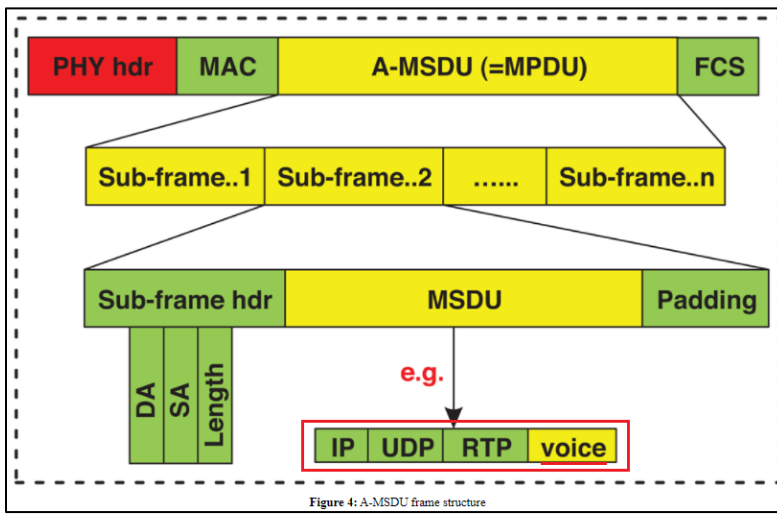

Figure 4: A-MSDU frame structure

Source: <https://www.techscience.com/cmc/v66n2/40658/html>

60. The method practiced using the accused products further comprises the step of receiving/sending, by wireless near field communication means, of said received data or said transmission data in said data packet format from/to said protocol means, embedding said transmission data in said data packet format received from said protocol means in a WiFi or

IEEE 802.11 format and extracting said received data in said data format from said WiFi or IEEE 802.11 format.

61. For example, a Coolpad Legacy device supports Wi-Fi calling/Voice over Wi-Fi (VoWi-Fi). VoWi-Fi enables a user to make and receive calls over the internet. As one example, when a calling party establishes a call using the VoWi-Fi feature, the voice input is processed and encapsulated into IP packets (“data packet format”) by the device. Further, when voice data is received at the calling party’s device, the data is processed and the encapsulated IP packets, including the packetized voice data, are extracted. A Coolpad Legacy device includes a processor (“protocol means”) for embedding and extracting the digital data into/from IP packets, respectively.

62. The IP packets (“data packet format”) received from the protocol means are then embedded into PPDU (PLCP (Physical Layer Convergence Protocol) protocol Data Unit) frames (WiFi or IEEE 802.11 format) by adding appropriate headers, such as Physical layer and MAC layer headers. The Coolpad Legacy device includes a Wi-Fi chipset (“wireless near field communication means”) for embedding the IP packets into the IEEE 802.11 frame format (PPDUs).

63. When the calling party receives the voice data (PPDUs) from the wireless network, the embedded IP packets are extracted from these PPDU frames by the removal of appropriate headers. The received PPDU frames (WiFi or IEEE 802.11 format) correspond to the IEEE 802.11 protocol. The extracted IP packets, including the packetized voice data, are then sent to the protocol means for further processing. The Wi-Fi chipset (“wireless near field communication means”) extracts the IP packets from the received PPDUs and sends them to the protocol means.

**coolpad Legacy™** FEATURES GALLERY TECH SPECS BUY NOW

**TECH SPECS** MORE PRODUCT DETAILS

<p><b>Design</b></p> <p>Size: 6.53" x 3.17" x .33" Weight: 5.99 oz. Color: Quicksilver</p>	<p><b>Display</b></p> <p>Display Size: 6.36" FHD+ Screen resolution: 2160 x 1080p Aspect ratio: 18:9 Protection: Gorilla® Glass 3</p>	<p><b>Battery</b></p> <p>4,000mAh Battery Talk Time: Up to 42.6 Hours Standby Time: Up to 585 Hours Usage Time: Up to 5.3 Hours LTE Charging Time (Full): 2.5 Hours USB Type: Type C</p>
<p><b>Features &amp; OS</b></p> <p>Qualcomm SDM450 1.8 GHz Octa Core Android 9 Pie</p>	<p><b>Memory</b></p> <p>Memory: 32GB ROM/3GB RAM Available User Memory: 21GB MicroSD Support: Up to 128GB</p>	<p><b>Connectivity</b></p> <p>2G GSM: 850/900/1800/1900 3G WCDMA: B2/4/5 4G LTE: B2/4/5/12/66/71 VoLTE Capable: Yes <u>Wi-Fi Calling Capable: Yes</u> Wi-Fi: 802.11 a/b/g/n/ac</p>

Source: <https://coolpad.us/legacy/>

**What is VoWiFi?**

Voice over Wi-Fi (VoWiFi), as the name implies, is delivering voice service via WiFi network. Users can make calls without the need of mobile signal. VoWiFi is a complementary technology to Voice over LTE (VoLTE). Both make use of the IP Multimedia Subsystem (IMS) technology to realize the voice traffic as IP packets.

Source: <https://insinuator.net/2016/10/a-journey-into-the-depths-of-vowifi-security/>

**Datalink layer (Layer 2)**

The data packet generated at **Network layer** is then placed inside Datalink layer header and trailer (Layer 2 header and trailer). Values inside Datalink layer header and trailer are relevant for processing data at **Datalink layer**.

The data packet at the **Datalink layer**, which encapsulates and may subdivide the **IP Datagram**, is known as a "**Frame**" (generally **Ethernet Frame**).

The most important values at Datalink layer header (Layer 2 header) are source and destination **MAC addresses (Layer 2 addresses)**. Following image represents data packet generated at **Datalink layer**.

Source: <https://www.omniseccu.com/tcpip/tcpip-encapsulation-decapsulation.php>

**Datalink Layer (Layer 2)**

Receiver opens the Datalink layer header and trailer (Layer 2 header and trailer), uses the values at **Datalink header and trailer** for processing data at the **Datalink layer**.

Receiver then collects the Network layer packet (IPv4 or IPv6 Datagram), and it is transferred to **Network layer** for further processing.

Source: <https://www.omniseccu.com/tcpip/tcpip-encapsulation-decapsulation.php>

**physical layer (PHY) protocol data unit (PPDU):** The unit of data exchanged between two peer PHY entities to provide the PHY data service.

Source: <https://ieeexplore.ieee.org/document/7786995> (Page 138)

- When the Network layer (layer 3) sends data to the Data-Link layer, that data is handed off to the LLC and becomes known as the MAC Service Data Unit (MSDU).
- The payload of a 802.11 data frame is the layer 3-7 information known as the MSDU.
- A simple definition of the MSDU is that it is the data payload that contains the IP packet plus some LLC data.

Source: <https://dot11ap.wordpress.com/msdu-and-mpdu/>

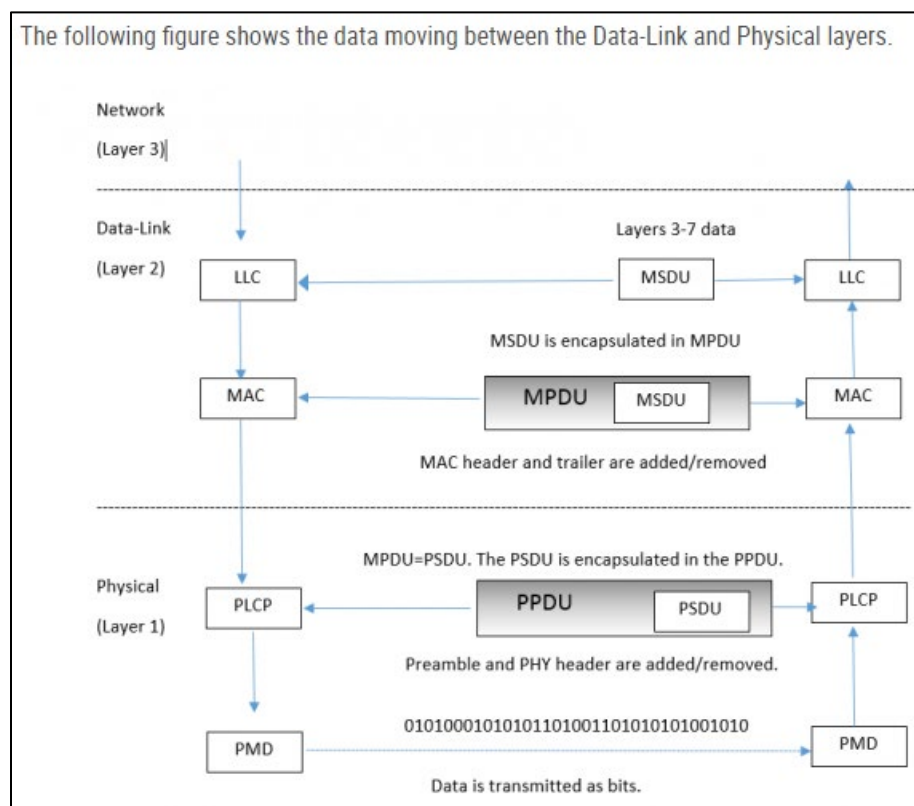

Source: <https://www.cwnp.com/802.11-mac-series-ndash-basics-mac-architecture-ndash-part-1-3/>

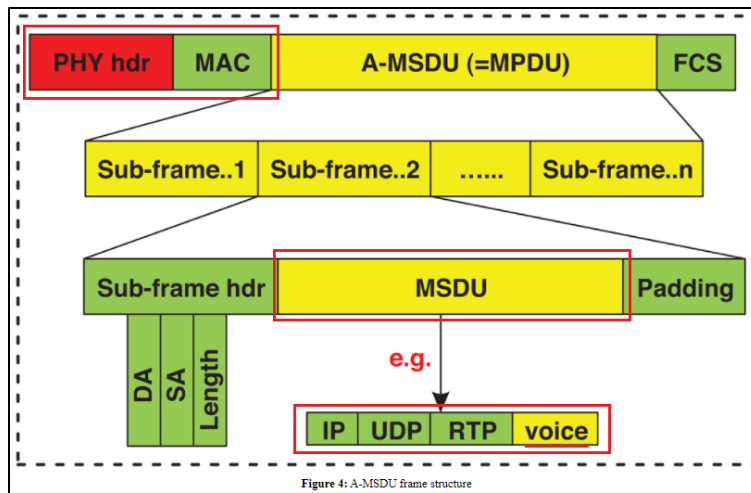

Source: <https://www.techscience.com/cmc/v66n2/40658/html>

64. The method practiced using the accused products further comprises communicating, by said wireless near field communication means, said received data or said transmission data embedded in said WiFi or IEEE 802.11 format with a connecting unit communicating in said WiFi or IEEE 802.11 format to establish a connection to a network according to said standardized network protocol, whereby the resulting data exchanged between the wireless near field communication means and the connecting unit include packets in said data packet format embedded in said WiFi or IEEE 802.11 format.

65. For example, a Coolpad Legacy device supports Wi-Fi calling/Voice over Wi-Fi (VoWi-Fi). VoWi-Fi enables a user to make and receive calls over the internet. As one example, when a calling party establishes a call using the VoWi-Fi feature, the calling party's device embeds the digital voice data into IP packets. These IP packets ("data packet format") are then embedded into PPDUs frames (WiFi or IEEE 802.11 format) by adding appropriate headers, such as Physical layer and MAC layer headers. The Coolpad Legacy device includes a Wi-Fi chipset ("wireless near field communication means") for embedding the IP packets into the IEEE 802.11 frame format (PPDUs).

66. The Wi-Fi chipset (“wireless near field communication means”) of the device transmits the PPDUs (“transmission data embedded in WiFi or IEEE 802.11 format”) to the 802.11 router/access point (“connecting unit”) using corresponding wireless communication antennas. The Wi-Fi chipset of the device also receives PPDUs (“received data”) from the 802.11 router/access point (“connecting unit”) using corresponding wireless communication antennas. These PPDUs correspond to IEEE 802.11 frame format (“WiFi or IEEE 802.11 format”) and include the embedded IP (“first data packet format”) packets with packetized voice data.

67. Further, the 802.11 access points are connected to the internet according to the Internet Protocol (“standardized network protocol”).

**coolpad Legacy™**      FEATURES   GALLERY   TECH SPECS   BUY NOW

**TECH SPECS**    MORE PRODUCT DETAILS

- Design**  
Size: 6.53" x 3.17" x .33"  
Weight: 5.99 oz.  
Color: Quicksilver
- Display**  
Display Size: 6.36" FHD+  
Screen resolution: 2160 x 1080p  
Aspect ratio: 18:9  
Protection: Gorilla® Glass 3
- Battery**  
4,000mAh Battery  
Talk Time: Up to 42.6 Hours  
Standby Time: Up to 585 Hours  
Usage Time: Up to 5.3 Hours LTE  
Charging Time (Full): 2.5 Hours  
USB Type: Type C
- Features & OS**  
Qualcomm SDM450  
1.8 GHz Octa Core  
Android 9 Pie
- Memory**  
Memory: 32GB ROM/3GB RAM  
Available User Memory: 21GB  
MicroSD Support: Up to 128GB
- Connectivity**  
2G GSM: 850/900/1800/1900  
3G WCDMA: B2/4/5  
4G LTE: B2/4/5/12/66/71  
VoLTE Capable: Yes  
Wi-Fi Calling Capable: Yes  
Wi-Fi: 802.11 a/b/g/n/ac

Source: <https://coolpad.us/legacy/>

### What is VoWiFi?

Voice over Wi-Fi (VoWiFi), as the name implies, is delivering voice service via WiFi network. Users can make calls without the need of mobile signal. VoWiFi is a complementary technology to Voice over LTE (VoLTE). Both make use of the IP Multimedia Subsystem (IMS) technology to realize the voice traffic as IP packets.

Source: <https://insinuator.net/2016/10/a-journey-into-the-depths-of-vowifi-security/>

### Datalink layer (Layer 2)

The data packet generated at **Network layer** is then placed inside **Datalink layer header and trailer (Layer 2 header and trailer)**. Values inside Datalink layer header and trailer are relevant for processing data at **Datalink layer**.

The data packet at the **Datalink layer**, which encapsulates and may subdivide the **IP Datagram**, is known as a "**Frame**" (generally **Ethernet Frame**).

The most important values at Datalink layer header (Layer 2 header) are source and destination **MAC addresses (Layer 2 addresses)**. Following image represents data packet generated at **Datalink layer**.

Source: <https://www.omniseccu.com/tcpip/tcpip-encapsulation-decapsulation.php>

### Datalink Layer (Layer 2)

Receiver opens the **Datalink layer header and trailer (Layer 2 header and trailer)**, uses the values at **Datalink header and trailer** for processing data at the **Datalink layer**.

Receiver then collects the Network layer packet (IPv4 or IPv6 Datagram), and it is transferred to **Network layer** for further processing.

Source: <https://www.omniseccu.com/tcpip/tcpip-encapsulation-decapsulation.php>

**physical layer (PHY) protocol data unit (PPDU):** The unit of data exchanged between two peer PHY entities to provide the PHY data service.

Source: <https://ieeexplore.ieee.org/document/7786995> (Page 138)

- When the Network layer (layer 3) sends data to the Data-Link layer, that data is handed off to the LLC and becomes known as the MAC Service Data Unit (MSDU).
- The payload of a 802.11 data frame is the layer 3-7 information known as the MSDU.
- A simple definition of the MSDU is that it is the data payload that contains the IP packet plus some LLC data.

Source: <https://dot11ap.wordpress.com/msdu-and-mpdu/>



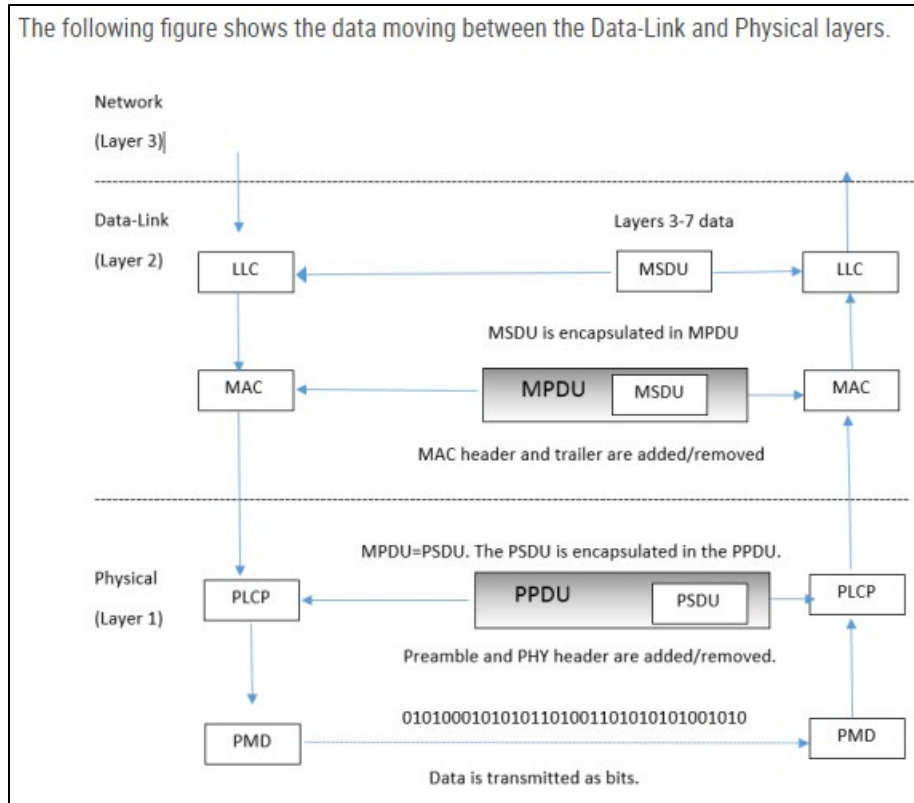

Source: <https://www.cwnp.com/802.11-mac-series-ndash-basics-mac-architecture-ndash-part-1-3/>

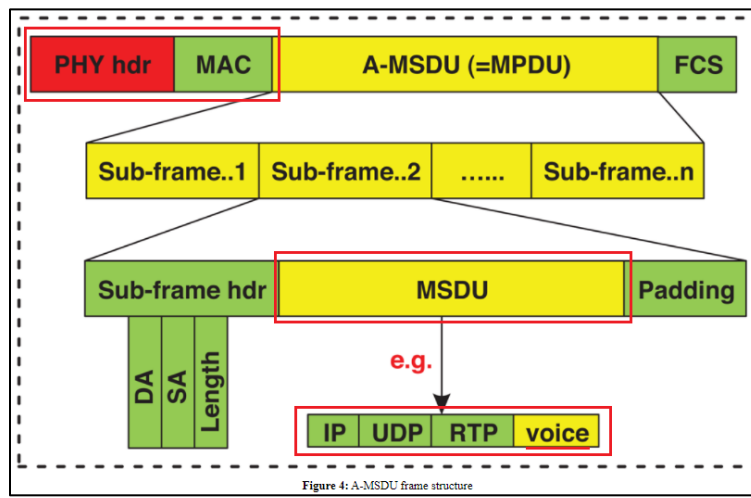

Source: <https://www.techscience.com/cmc/v66n2/40658/html>



Source: <https://whatis.techtarget.com/definition/Wi-Fi-calling>

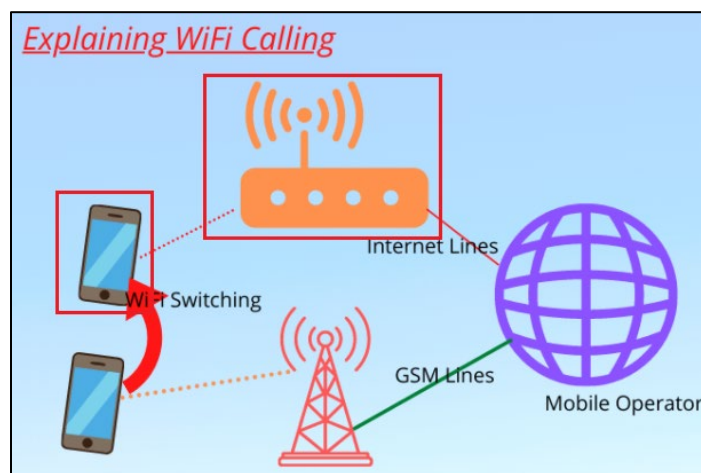

Source: <https://www.cspprotocol.com/what-is-wifi-calling/>

68. Buffalo Patents has been damaged as a result of the infringing conduct by Coolpad alleged above. Thus, Coolpad is liable to Buffalo Patents in an amount that adequately compensates it for such infringements, which, by law, cannot be less than a reasonable royalty, together with interest and costs as fixed by this Court under 35 U.S.C. § 284.

69. Buffalo Patents is only asserting method claims for the '915 Patent, and therefore, 35 U.S.C § 287(a) does not apply.

### COUNT III

#### DIRECT INFRINGEMENT OF U.S. PATENT NO. 8,611,328

70. On December 17, 2013, United States Patent No. 8,611,328 (“the ’328 Patent”) was duly and legally issued by the United States Patent and Trademark Office for an invention entitled “Communications Terminal, a System and a Method for Internet/Network Telephony.”

71. Buffalo Patents is the owner of the ’328 Patent, with all substantive rights in and to that patent, including the sole and exclusive right to prosecute this action and enforce the ’328 Patent against infringers, and to collect damages for all relevant times.

72. Coolpad made, had made, used, imported, provided, supplied, distributed, sold, and/or offered for sale products and/or systems including, for example, its Coolpad Legacy family of products that support Voice over Wi-Fi (VoWi-Fi) or Wi-Fi calling (“accused products”):

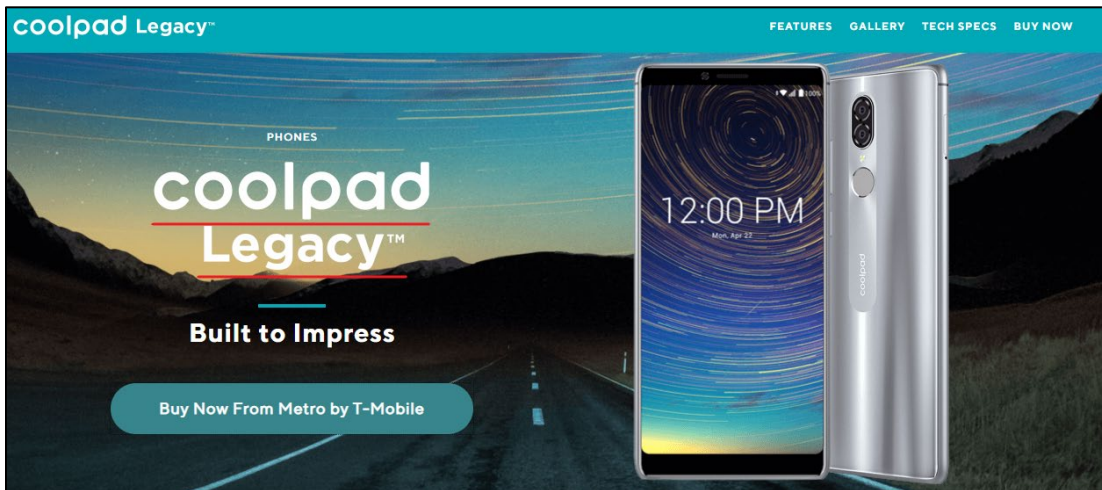

Source: <https://coolpad.us/legacy/>.

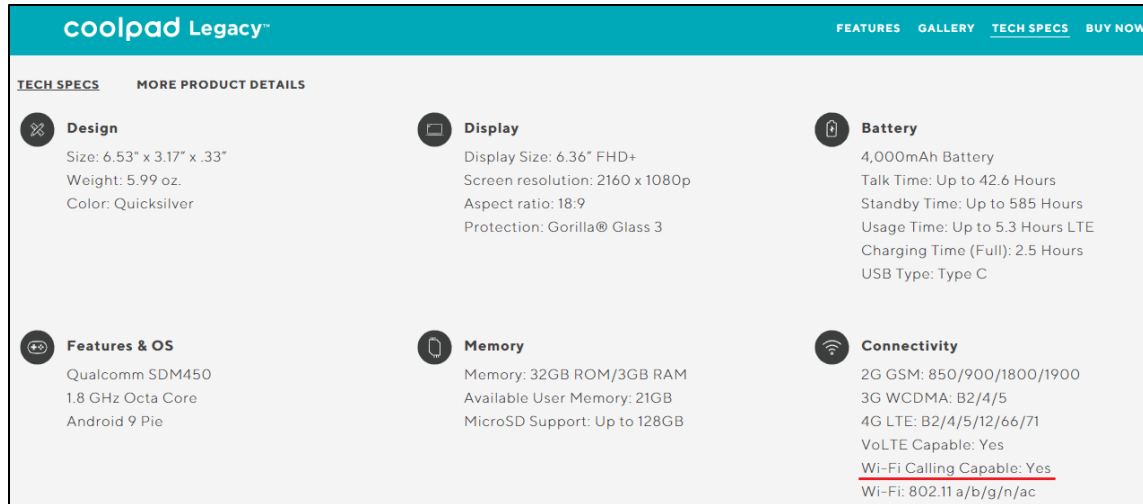

Source: <https://coolpad.us/legacy/>

73. By doing so, Coolpad has directly infringed (literally and/or under the doctrine of equivalents) at least Claim 8 of the '328 Patent. Coolpad's infringement in this regard is ongoing.

74. Coolpad Legacy devices are exemplary accused products.

75. Coolpad has infringed the '328 Patent by using the accused products and thereby practicing a method comprising converting a first signal representing detected sound to first digital data.

76. For example, a Coolpad Legacy device supports Wi-Fi calling/Voice over Wi-Fi (VoWi-Fi). VoWi-Fi enables a user to make and receive calls over the internet. A Coolpad Legacy device includes a codec (coder/decoder) to convert analog voice input into digital data and vice versa. As one example, when a user establishes a call using the VoWi-Fi feature, the sound waves generated by the user are converted into analog electrical signals ("first signal") by a microphone. The electrical signals contain the voice data, which is compressed and converted into digital data ("first digital data") with the help of a codec.

**coolpad Legacy™**      FEATURES   GALLERY   TECH SPECS   BUY NOW

**TECH SPECS**      MORE PRODUCT DETAILS

- Design**  
Size: 6.53" x 3.17" x .33"  
Weight: 5.99 oz.  
Color: Quicksilver
- Display**  
Display Size: 6.36" FHD+  
Screen resolution: 2160 x 1080p  
Aspect ratio: 18:9  
Protection: Gorilla® Glass 3
- Battery**  
4,000mAh Battery  
Talk Time: Up to 42.6 Hours  
Standby Time: Up to 585 Hours  
Usage Time: Up to 5.3 Hours LTE  
Charging Time (Full): 2.5 Hours  
USB Type: Type C
- Features & OS**  
Qualcomm SDM450  
1.8 GHz Octa Core  
Android 9 Pie
- Memory**  
Memory: 32GB ROM/3GB RAM  
Available User Memory: 21GB  
MicroSD Support: Up to 128GB
- Connectivity**  
2G GSM: 850/900/1800/1900  
3G WCDMA: B2/4/5  
4G LTE: B2/4/5/12/66/71  
VoLTE Capable: Yes  
Wi-Fi Calling Capable: Yes  
Wi-Fi: 802.11 a/b/g/n/ac

Source: <https://coolpad.us/legacy/>

**Wireless Settings**

**Connecting to a Wi-Fi Network**

1. On the Home screen, swipe up and then tap to enter the Settings screen. Then, choose **Network & internet** > **Wi-Fi** to turn Wi-Fi on/off.
2. Drag the slider to On enabling your phone to scan for available Wi-Fi networks.
3. Tap the name of a desired network to connect, entering the password if necessary.

Note: Previously connected and saved networks will be automatically joined. A user can join a network and forget it, removing it from the known networks list.

**Wi-Fi Calling**  
Wi-Fi Calling allows you to make and receive phone calls and messages over a Wi-Fi connection.

Source:

[https://coolpadsupport.zendesk.com/hc/article\\_attachments/360034048814/Coolpad\\_Legacy\\_QS\\_G\\_English\\_Spanish.pdf](https://coolpadsupport.zendesk.com/hc/article_attachments/360034048814/Coolpad_Legacy_QS_G_English_Spanish.pdf) (Page 1)

**What is Voice over Wi-Fi?**

Voice over Wi-Fi (VoWi-Fi) refers to the use of IEEE 802.11 wireless LANs (WLANs) to transport Voice over IP (VoIP) traffic. The technology has consumer, business and service provider applications. It is used over private WLANs, home Wi-Fi networks and public Wi-Fi hotspots.

Source: <https://ribboncommunications.com/company/get-help/glossary/voice-over-wi-fi>

### Microphone

The microphone changes the sound waves from your voice into electrical signals that are sent to the audio amplifier of the radio components. A microphone is essentially a speaker that works in reverse. When sound waves from your voice move the membrane, they make tiny electric currents either by moving a coil of wire within a magnet or by compressing the membrane against carbon dust (see [How do microphones work?](#) for details).

Source: <https://electronics.howstuffworks.com/cordless-telephone4.htm>

The dual-purpose nano SIM card / MicroSD card tray resides on the left edge, while the power and volume buttons reside on the right. At the top you'll find a microphone and a 3.5mm headphone jack. The bottom edge plays host to the USB-C port and two speaker grilles: One for the 1W speaker and one for the main microphone. The front-facing camera and earpiece speaker sit within the phone's display header as usual.



Source: <https://www.androidauthority.com/coolpad-legacy-review-1001320/>

### 3. Codecs

The quality of voice is a characteristic on digital telephony. Since VoIP and VoWiFi combine digital telephony and networking technologies they also have the quality of voice characteristic. An important element that controls the quality of voice is the compression, and conversion of analog to digital (codec) used on the voice traffic. There are numerous codecs defined for use with voice traffic. The following sections will introduce and give an overview of a few current codecs in use.

Source: [https://www.cse.wustl.edu/~jain/cse574-06/ftp/wireless\\_voip/index.html](https://www.cse.wustl.edu/~jain/cse574-06/ftp/wireless_voip/index.html)

Baseband part in a mobile is comprised of a digital signal processor (DSP) to process forward voice/data signals for transmission and to process reverse voice/data signals received.

This is the core processing part which changes for various air interface standards like GSM, HSPA, LTE and more. It is often named as physical layer or Layer 1 or L1. For Speech/audio, codec is used to compress and decompress the signal to match the data rate to the frame it has to fit in. The baseband or physical layer will add redundant bits to enable error detection as well as error correction. Error detection is obtained with CRC and error correction with forward error correction techniques. Other than this interleaving is done for the data of one burst which helps in spreading the error over the time hence helps receiver de-interleave and decode the frame (consecutively data burst) correctly.

**Source:** <https://insinuator.net/2016/10/a-journey-into-the-depths-of-vowifi-security/>

77. The method practiced using the accused products further comprises converting the first digital data into one or more first data packets that accord to a network protocol of a first network.

78. For example, a Coolpad Legacy device supports Wi-Fi calling/Voice over Wi-Fi (VoWi-Fi). VoWi-Fi enables a user to make and receive calls over the internet. As one example, when a user establishes a call using the VoWi-Fi feature, the voice data from the caller is compressed and converted into digital data. The digital data (“first digital data”) is encapsulated into IP packets (“first data packets”). These IP packets correspond to the Internet protocol (“network protocol of a first network”).

**coolpad Legacy™**      FEATURES   GALLERY   TECH SPECS   BUY NOW

**TECH SPECS**      MORE PRODUCT DETAILS

- Design**  
Size: 6.53" x 3.17" x .33"  
Weight: 5.99 oz.  
Color: Quicksilver
- Display**  
Display Size: 6.36" FHD+  
Screen resolution: 2160 x 1080p  
Aspect ratio: 18:9  
Protection: Gorilla® Glass 3
- Battery**  
4,000mAh Battery  
Talk Time: Up to 42.6 Hours  
Standby Time: Up to 585 Hours  
Usage Time: Up to 5.3 Hours LTE  
Charging Time (Full): 2.5 Hours  
USB Type: Type C
- Features & OS**  
Qualcomm SDM450  
1.8 GHz Octa Core  
Android 9 Pie
- Memory**  
Memory: 32GB ROM/3GB RAM  
Available User Memory: 21GB  
MicroSD Support: Up to 128GB
- Connectivity**  
2G GSM: 850/900/1800/1900  
3G WCDMA: B2/4/5  
4G LTE: B2/4/5/12/66/71  
VoLTE Capable: Yes  
Wi-Fi Calling Capable: Yes  
Wi-Fi: 802.11 a/b/g/n/ac

Source: <https://coolpad.us/legacy/>

**What is Voice over Wi-Fi?**  
Voice over Wi-Fi (VoWi-Fi) refers to the use of IEEE 802.11 wireless LANs (WLANs) to transport Voice over IP (VoIP) traffic. The technology has consumer, business and service provider applications. It is used over private WLANs, home Wi-Fi networks and public Wi-Fi hotspots.

Source: <https://ribboncommunications.com/company/get-help/glossary/voice-over-wi-fi>

**What is VoWiFi?**  
Voice over Wi-Fi (VoWiFi), as the name implies, is delivering voice service via WiFi network. Users can make calls without the need of mobile signal. VoWiFi is a complementary technology to Voice over LTE (VoLTE). Both make use of the IP Multimedia Subsystem (IMS) technology to realize the voice traffic as IP packets.

Source: <https://insinuator.net/2016/10/a-journey-into-the-depths-of-vowifi-security/>



### Transport Layer (Layer 4)

Transport layer adds many information with original data as Transport layer header (Layer 4 header), which are relevant for data processing at the Transport layer.

The Application layer message is encapsulated at the Transport layer. If the protocol used at the Transport Layer is TCP (Transmission Control Protocol), the data packet is known as "TCP Segment". If the protocol used at the Transport layer is UDP (User Datagram Protocol), the data packet is known as "UDP Datagram".

### Network Layer (Layer 3)

Network layer adds additional data as header, which are relevant for processing data at Network layer.

The data packet created at the Network layer by Internet Protocol (IPv4 or IPv6), which encapsulates its upper layer Transport layer segment/datagram, is known as "IP Datagram".

Source: <https://www.omniseccu.com/tcpip/tcpip-encapsulation-decapsulation.php>

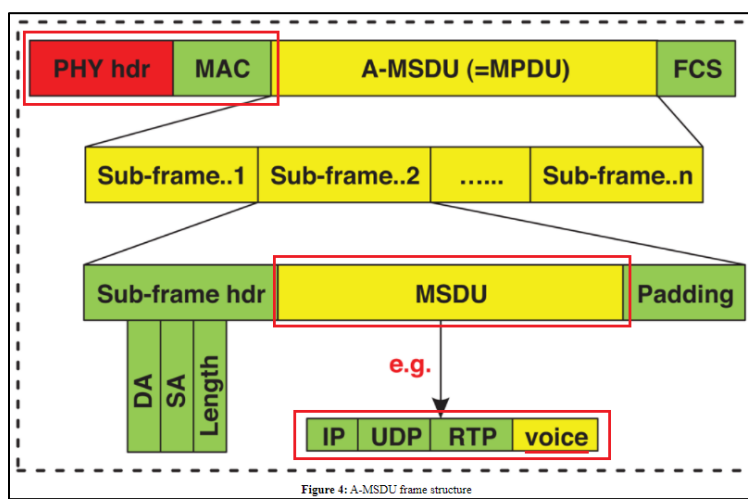

Source: <https://www.techscience.com/cmc/v66n2/40658/html>

79. The method practiced using the accused products further comprises embedding the one or more first data packets into first wireless data that accords to a network protocol of a near field communication network.

80. For example, a Coolpad Legacy device supports Wi-Fi calling/Voice over Wi-Fi (VoWi-Fi). VoWi-Fi enables a user to make and receive calls over the internet. As one example, when a user establishes a call using the VoWi-Fi feature, the voice data is compressed and encapsulated into IP packets. The IP packets ("first data packets") are embedded into PPDU (PLCP (Physical Layer Convergence Protocol) protocol Data Unit) frames by adding appropriate

headers, such as Physical layer and MAC layer headers. The PPDU (“first wireless data”) are formatted according to the 802.11 protocol (“network protocol of a near field communication network”) frame format.

The screenshot shows the product page for the Coolpad Legacy smartphone. The page is titled "coolpad Legacy™" and has navigation links for "FEATURES", "GALLERY", "TECH SPECS", and "BUY NOW". Under the "TECH SPECS" section, there are six categories of specifications:

- Design:** Size: 6.53" x 3.17" x .33", Weight: 5.99 oz., Color: Quicksilver
- Display:** Display Size: 6.36" FHD+, Screen resolution: 2160 x 1080p, Aspect ratio: 18:9, Protection: Gorilla® Glass 3
- Battery:** 4,000mAh Battery, Talk Time: Up to 42.6 Hours, Standby Time: Up to 585 Hours, Usage Time: Up to 5.3 Hours LTE, Charging Time (Full): 2.5 Hours, USB Type: Type C
- Features & OS:** Qualcomm SDM450, 1.8 GHz Octa Core, Android 9 Pie
- Memory:** Memory: 32GB ROM/3GB RAM, Available User Memory: 21GB, MicroSD Support: Up to 128GB
- Connectivity:** 2G GSM: 850/900/1800/1900, 3G WCDMA: B2/4/5, 4G LTE: B2/4/5/12/66/71, VoLTE Capable: Yes, Wi-Fi Calling Capable: Yes, Wi-Fi: 802.11 a/b/g/n/ac

Source: <https://coolpad.us/legacy/>

The screenshot shows an article titled "What is VoWiFi?". The text explains that Voice over Wi-Fi (VoWiFi) is delivering voice service via WiFi network. Users can make calls without the need of mobile signal. VoWiFi is a complementary technology to Voice over LTE (VoLTE). Both make use of the IP Multimedia Subsystem (IMS) technology to realize the voice traffic as IP packets.

Source: <https://insinuator.net/2016/10/a-journey-into-the-depths-of-vowifi-security/>

The screenshot shows an article titled "Datalink layer (Layer 2)". The text explains that the data packet generated at Network layer is then placed inside Datalink layer header and trailer (Layer 2 header and trailer). Values inside Datalink layer header and trailer are relevant for processing data at Datalink layer. The data packet at the Datalink layer, which encapsulates and may subdivide the IP Datagram, is known as a "Frame" (generally Ethernet Frame). The most important values at Datalink layer header (Layer 2 header) are source and destination MAC addresses (Layer 2 addresses). Following image represents data packet generated at Datalink layer.

Source: <https://www.omniseccu.com/tcpip/tcpip-encapsulation-decapsulation.php>

**physical layer (PHY) protocol data unit (PPDU):** The unit of data exchanged between two peer PHY entities to provide the PHY data service.

Source: <https://ieeexplore.ieee.org/document/7786995> (Page 138)

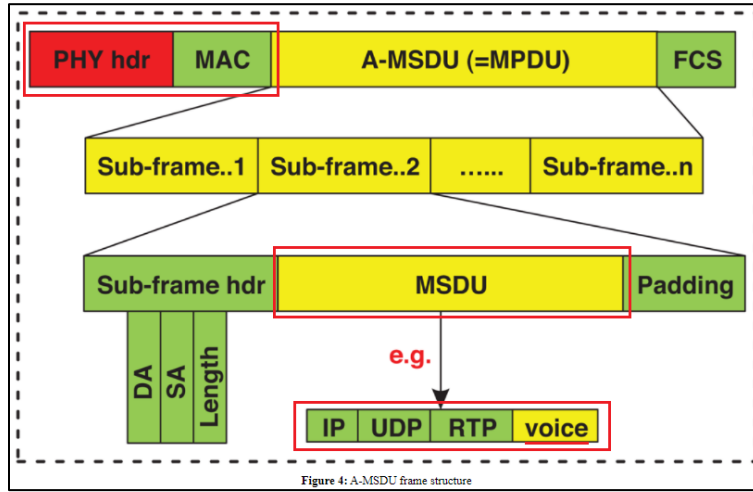

Source: <https://www.techscience.com/cmc/v66n2/40658/html>

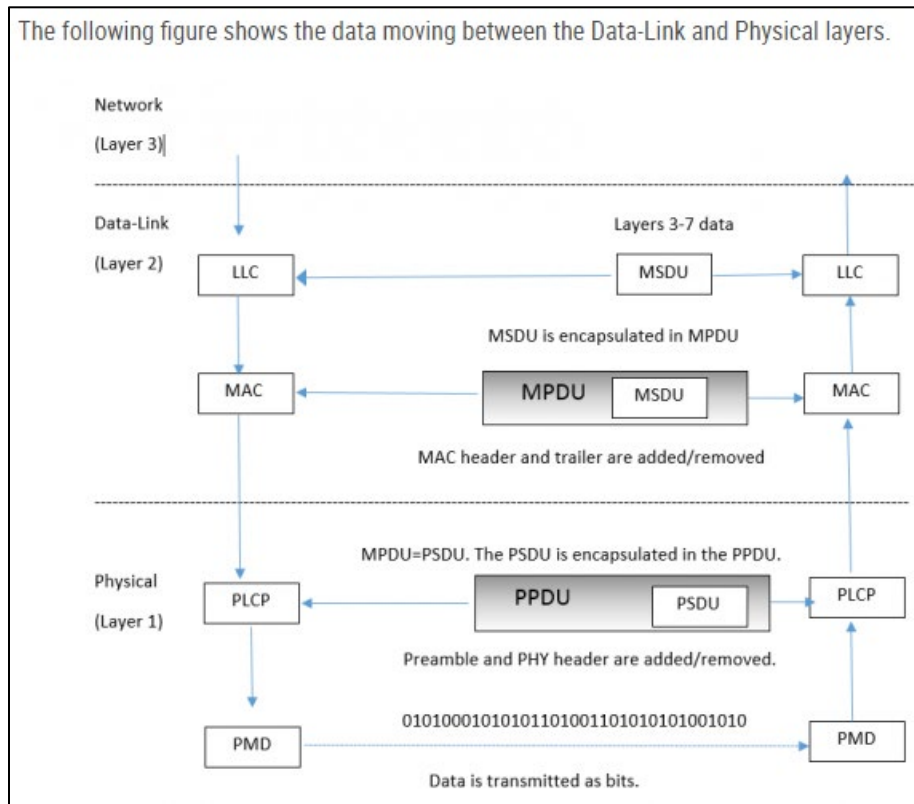

Source: <https://www.cwnp.com/802.11-mac-series-ndash-basics-mac-architecture-ndash-part-1-3/>

- When the Network layer (layer 3) sends data to the Data-Link layer, that data is handed off to the LLC and becomes known as the MAC Service Data Unit (MSDU).
- The payload of a 802.11 data frame is the layer 3-7 information known as the MSDU.
- A simple definition of the MSDU is that it is the data payload that contains the IP packet plus some LLC data.

Source: <https://dot11ap.wordpress.com/msdu-and-mpdu/>

81. The method practiced using the accused products further comprises transmitting the first wireless data via the near field communication network in accordance with the network protocol of the second network.

82. For example, a Coolpad Legacy device supports Wi-Fi calling/Voice over Wi-Fi (VoWi-Fi). VoWi-Fi enables a user to make and receive calls over the internet using Wi-Fi access points. VoWi-Fi allows the delivery of voice traffic as IP packets via a Wi-Fi network.

83. As one example, when a user establishes a call using the VoWi-Fi feature, the voice data is compressed and encapsulated into IP packets and further embedded into PPDU frames. The PPDU data corresponds to the 802.11 protocol (“network protocol of the second network”). The PPDU frames are then transmitted using Wi-Fi access points (“near field communication network”).

The screenshot shows the 'coolpad Legacy™' product page. The navigation bar includes 'FEATURES', 'GALLERY', 'TECH SPECS', and 'BUY NOW'. The 'TECH SPECS' section is active, displaying the following details:

- Design:** Size: 6.53" x 3.17" x .33", Weight: 5.99 oz., Color: Quicksilver
- Display:** Display Size: 6.36" FHD+, Screen resolution: 2160 x 1080p, Aspect ratio: 18:9, Protection: Gorilla® Glass 3
- Battery:** 4,000mAh Battery, Talk Time: Up to 42.6 Hours, Standby Time: Up to 585 Hours, Usage Time: Up to 5.3 Hours LTE, Charging Time (Full): 2.5 Hours, USB Type: Type C
- Features & OS:** Qualcomm SDM450, 1.8 GHz Octa Core, Android 9 Pie
- Memory:** Memory: 32GB ROM/3GB RAM, Available User Memory: 21GB, MicroSD Support: Up to 128GB
- Connectivity:** 2G GSM: 850/900/1800/1900, 3G WCDMA: B2/4/5, 4G LTE: B2/4/5/12/66/71, VoLTE Capable: Yes, Wi-Fi Calling Capable: Yes, Wi-Fi: 802.11 a/b/g/n/ac

Source: <https://coolpad.us/legacy/>

## What is Voice over Wi-Fi?

Voice over Wi-Fi (VoWi-Fi) refers to the use of IEEE 802.11 wireless LANs (WLANs) to transport Voice over IP (VoIP) traffic. The technology has consumer, business and service provider applications. It is used over private WLANs, home Wi-Fi networks and public Wi-Fi hotspots.

Source: <https://ribboncommunications.com/company/get-help/glossary/voice-over-wi-fi>

## What is VoWiFi?

Voice over Wi-Fi (VoWiFi), as the name implies, is delivering voice service via WiFi network. Users can make calls without the need of mobile signal. VoWiFi is a complementary technology to Voice over LTE (VoLTE). Both make use of the IP Multimedia Subsystem (IMS) technology to realize the voice traffic as IP packets.

Source: <https://insinuator.net/2016/10/a-journey-into-the-depths-of-vowifi-security/>

**physical layer (PHY) protocol data unit (PPDU):** The unit of data exchanged between two peer PHY entities to provide the PHY data service.

Source: <https://ieeexplore.ieee.org/document/7786995> (Page 138)

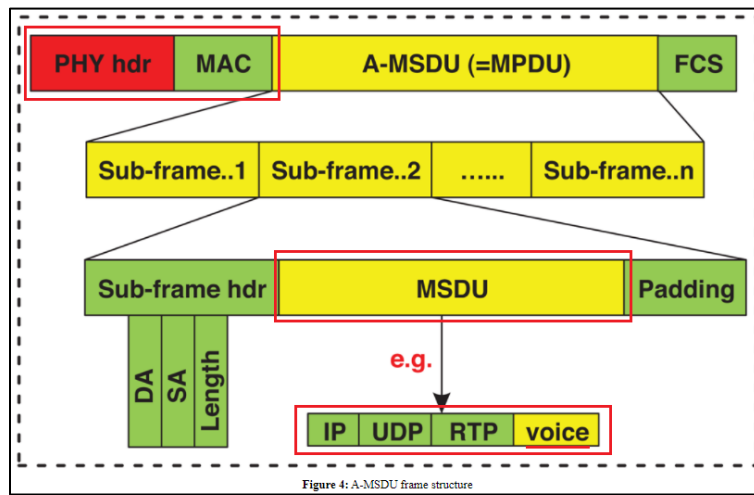

Source: <https://www.techscience.com/cmc/v66n2/40658/html>

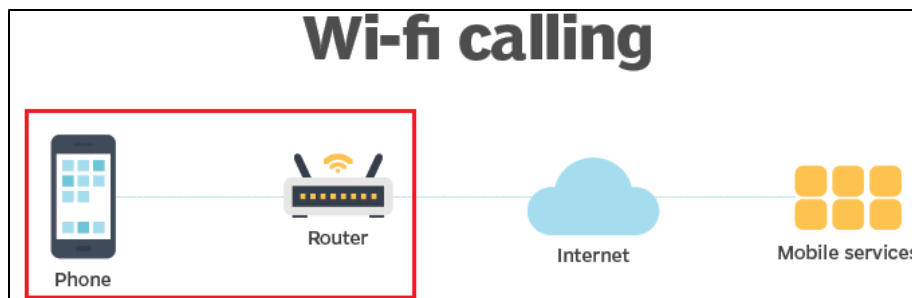

Source: <https://whatis.techtarget.com/definition/Wi-Fi-calling>

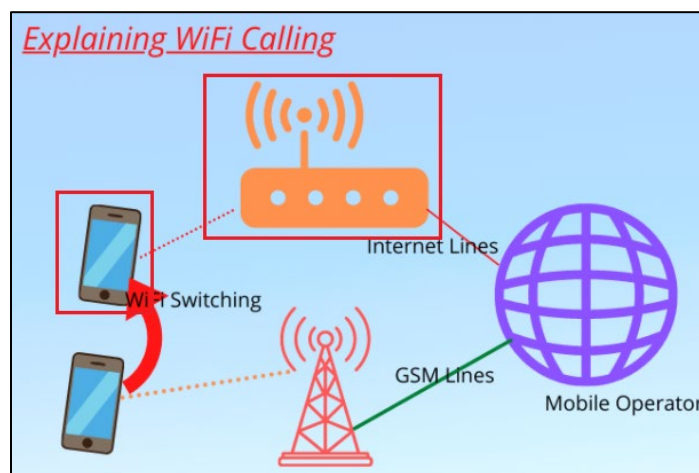

Source: <https://www.cspprotocol.com/what-is-wifi-calling/>

84. Buffalo Patents has been damaged as a result of the infringing conduct by Coolpad alleged above. Thus, Coolpad is liable to Buffalo Patents in an amount that adequately compensates it for such infringements, which, by law, cannot be less than a reasonable royalty, together with interest and costs as fixed by this Court under 35 U.S.C. § 284.

85. Buffalo Patents is only asserting method claims for the '328 Patent, and therefore, 35 U.S.C § 287(a) does not apply.

**COUNT IV**

**DIRECT INFRINGEMENT OF U.S. PATENT NO. 9,001,816**

86. On April 7, 2015, United States Patent No. 9,001,816 (“the ’816 Patent”) was duly and legally issued by the United States Patent and Trademark Office for an invention entitled “Communications Terminal, a System and a Method for Internet/Network Telephony.”

87. Buffalo Patents is the owner of the ’816 Patent, with all substantive rights in and to that patent, including the sole and exclusive right to prosecute this action and enforce the ’816 Patent against infringers, and to collect damages for all relevant times.

88. Coolpad made, had made, used, imported, provided, supplied, distributed, sold, and/or offered for sale products and/or systems including, for example, its Coolpad Legacy family of products that support Voice over Wi-Fi (VoWi-Fi) or Wi-Fi calling (“accused products”):

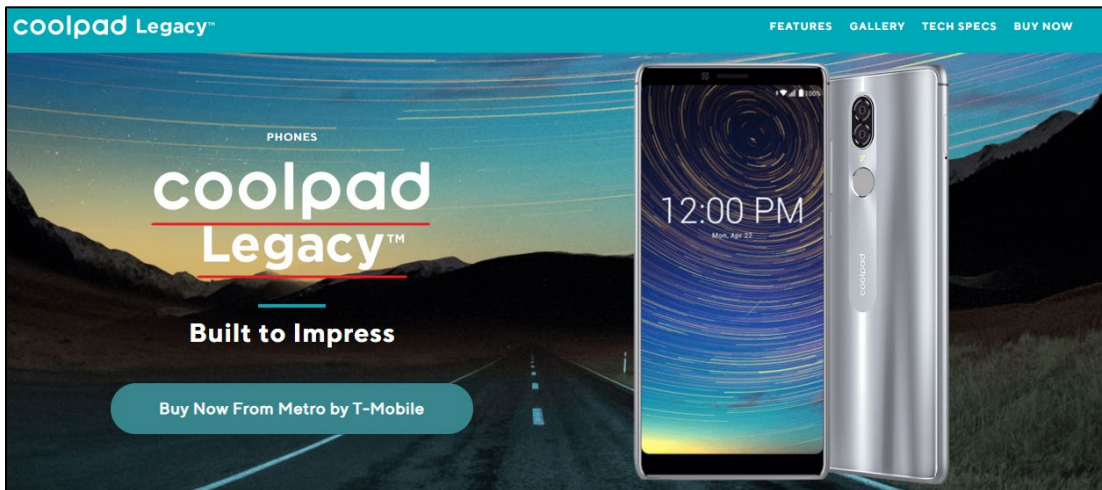

Source: <https://coolpad.us/legacy/>.

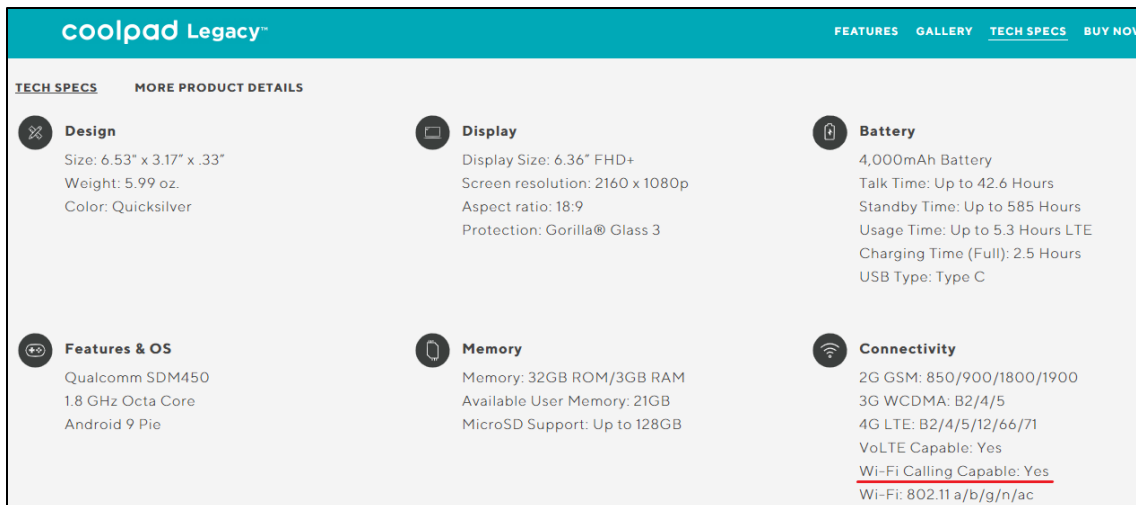

Source: <https://coolpad.us/legacy/>

89. By doing so, Coolpad has directly infringed (literally and/or under the doctrine of equivalents) at least Claim 10 of the '816 Patent. Coolpad's infringement in this regard is ongoing.

90. Coolpad Legacy devices are exemplary accused products.

91. Coolpad has infringed the '816 Patent by using the accused products and thereby practicing a method comprising receiving, via a near field network, wireless data that accords to a first network protocol, wherein the wireless data includes a data packet that accords to a second network protocol.

92. For example, a Coolpad Legacy device supports Wi-Fi calling/Voice over Wi-Fi (VoWi-Fi). VoWi-Fi enables a user to make and receive calls over the internet using Wi-Fi access points. VoWi-Fi allows the delivery of voice traffic as IP packets via a Wi-Fi network.

93. As one example, when a user (caller) establishes a call using the VoWi-Fi feature with another user (the receiver), the voice data from the caller is compressed and encapsulated into IP packets, and then formatted according to the IEEE 802.11 protocol frame format for transmission using 802.11 WLAN (Wireless Local Area Network) access points. The formatted



data is transmitted in the form of PPDU (PLCP (Physical Layer Convergence Protocol) protocol Data Unit). The receiver receives the transmitted PPDU via a Wi-Fi network (“near field network”). The PPDU (“wireless data”) received by the receiver correspond to the 802.11 protocol (“first network protocol”), and the IP packets (“data packet”) embedded in the PPDU correspond to the Internet protocol (“second network protocol”).

The screenshot shows the 'TECH SPECS' section of the Coolpad Legacy smartphone product page. The page is divided into six categories:

- Design:** Size: 6.53" x 3.17" x .33", Weight: 5.99 oz., Color: Quicksilver
- Display:** Display Size: 6.36" FHD+, Screen resolution: 2160 x 1080p, Aspect ratio: 18:9, Protection: Gorilla® Glass 3
- Battery:** 4,000mAh Battery, Talk Time: Up to 42.6 Hours, Standby Time: Up to 585 Hours, Usage Time: Up to 5.3 Hours LTE, Charging Time (Full): 2.5 Hours, USB Type: Type C
- Features & OS:** Qualcomm SDM450, 1.8 GHz Octa Core, Android 9 Pie
- Memory:** Memory: 32GB ROM/3GB RAM, Available User Memory: 21GB, MicroSD Support: Up to 128GB
- Connectivity:** 2G GSM: 850/900/1800/1900, 3G WCDMA: B2/4/5, 4G LTE: B2/4/5/12/66/71, VoLTE Capable: Yes, Wi-Fi Calling Capable: Yes, Wi-Fi: 802.11 a/b/g/n/ac

Source: <https://coolpad.us/legacy/>

## What is Voice over Wi-Fi?

Voice over Wi-Fi (VoWi-Fi) refers to the use of IEEE 802.11 wireless LANs (WLANs) to transport Voice over IP (VoIP) traffic. The technology has consumer, business and service provider applications. It is used over private WLANs, home Wi-Fi networks and public Wi-Fi hotspots.

Source: <https://ribboncommunications.com/company/get-help/glossary/voice-over-wi-fi>

## What is VoWiFi?

Voice over Wi-Fi (VoWiFi), as the name implies, is delivering voice service via WiFi network. Users can make calls without the need of mobile signal. VoWiFi is a complementary technology to Voice over LTE (VoLTE). Both make use of the IP Multimedia Subsystem (IMS) technology to realize the voice traffic as IP packets.

Source: <https://insinuator.net/2016/10/a-journey-into-the-depths-of-vowifi-security/>

**physical layer (PHY) protocol data unit (PPDU):** The unit of data exchanged between two peer PHY entities to provide the PHY data service.

Source: <https://ieeexplore.ieee.org/document/7786995> (Page 138)

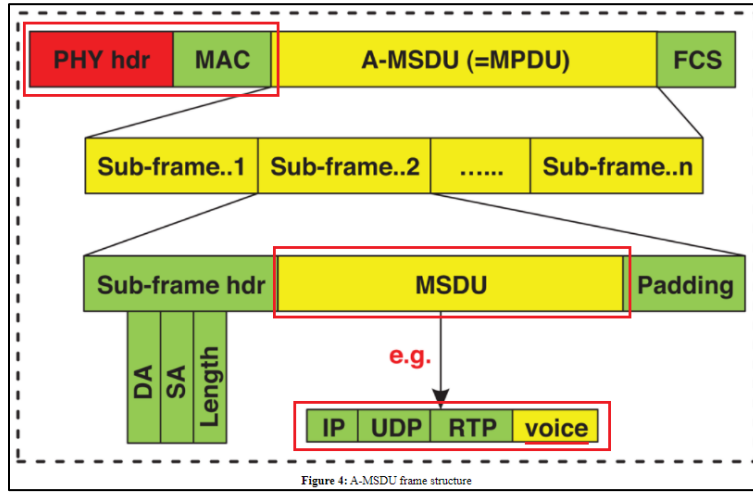

Source: <https://www.techscience.com/cmc/v66n2/40658/html>



Source: <https://whatis.techtarget.com/definition/Wi-Fi-calling>

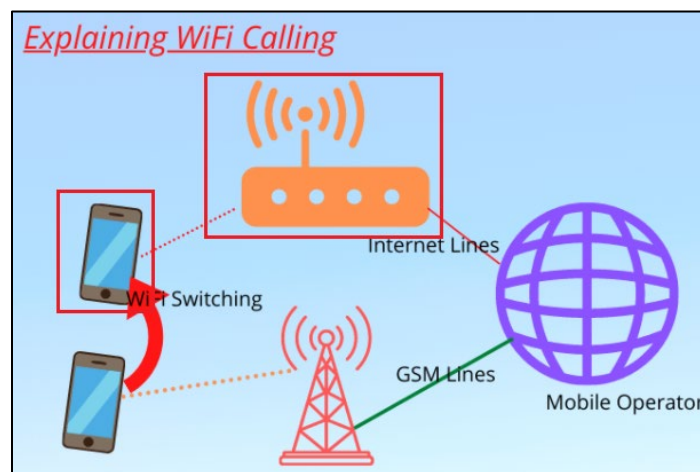

Source: <https://www.cspprotocol.com/what-is-wifi-calling/>

94. The method practiced using the accused products further comprises extracting the data packet from the wireless data.

95. For example, a Coolpad Legacy device supports Wi-Fi calling/Voice over Wi-Fi (VoWi-Fi). As one example, when a user (caller) establishes a call using the VoWi-Fi feature with another user (the receiver), the receiver receives transmitted PPDU's from a caller via a Wi-Fi network. The received PPDU's include appropriate headers, such as Physical layer and MAC layer headers. These headers are removed from the received PPDU's ("wireless data") in order to extract an IP packet ("data packet"), which includes the packetized voice data.

The screenshot shows the 'TECH SPECS' section of the Coolpad Legacy product page. It lists the following specifications:

- Design:** Size: 6.53" x 3.17" x .33", Weight: 5.99 oz., Color: Quicksilver
- Display:** Display Size: 6.36" FHD+, Screen resolution: 2160 x 1080p, Aspect ratio: 18:9, Protection: Gorilla® Glass 3
- Battery:** 4,000mAh Battery, Talk Time: Up to 42.6 Hours, Standby Time: Up to 585 Hours, Usage Time: Up to 5.3 Hours LTE, Charging Time (Full): 2.5 Hours, USB Type: Type C
- Features & OS:** Qualcomm SDM450, 1.8 GHz Octa Core, Android 9 Pie
- Memory:** Memory: 32GB ROM/3GB RAM, Available User Memory: 21GB, MicroSD Support: Up to 128GB
- Connectivity:** 2G GSM: 850/900/1800/1900, 3G WCDMA: B2/4/5, 4G LTE: B2/4/5/12/66/71, VoLTE Capable: Yes, Wi-Fi Calling Capable: Yes, Wi-Fi: 802.11 a/b/g/n/ac

Source: <https://coolpad.us/legacy/>

#### What is VoWiFi?

Voice over Wi-Fi (VoWiFi), as the name implies, is delivering voice service via WiFi network. Users can make calls without the need of mobile signal. VoWiFi is a complementary technology to Voice over LTE (VoLTE). Both make use of the IP Multimedia Subsystem (IMS) technology to realize the voice traffic as IP packets.

Source: <https://insinuator.net/2016/10/a-journey-into-the-depths-of-vowifi-security/>

### Datalink Layer (Layer 2)

Receiver opens the Datalink layer header and trailer (Layer 2 header and trailer), uses the values at Datalink header and trailer for processing data at the Datalink layer.

Receiver then collects the Network layer packet (IPv4 or IPv6 Datagram), and it is transferred to Network layer for further processing.

Source: <https://www.omniseccu.com/tcpip/tcpip-encapsulation-decapsulation.php>

- When the Network layer (layer 3) sends data to the Data-Link layer, that data is handed off to the LLC and becomes known as the MAC Service Data Unit (MSDU).
- The payload of a 802.11 data frame is the layer 3-7 information known as the MSDU.
- A simple definition of the MSDU is that it is the data payload that contains the IP packet plus some LLC data.

Source: <https://dot11ap.wordpress.com/msdu-and-mpdu/>

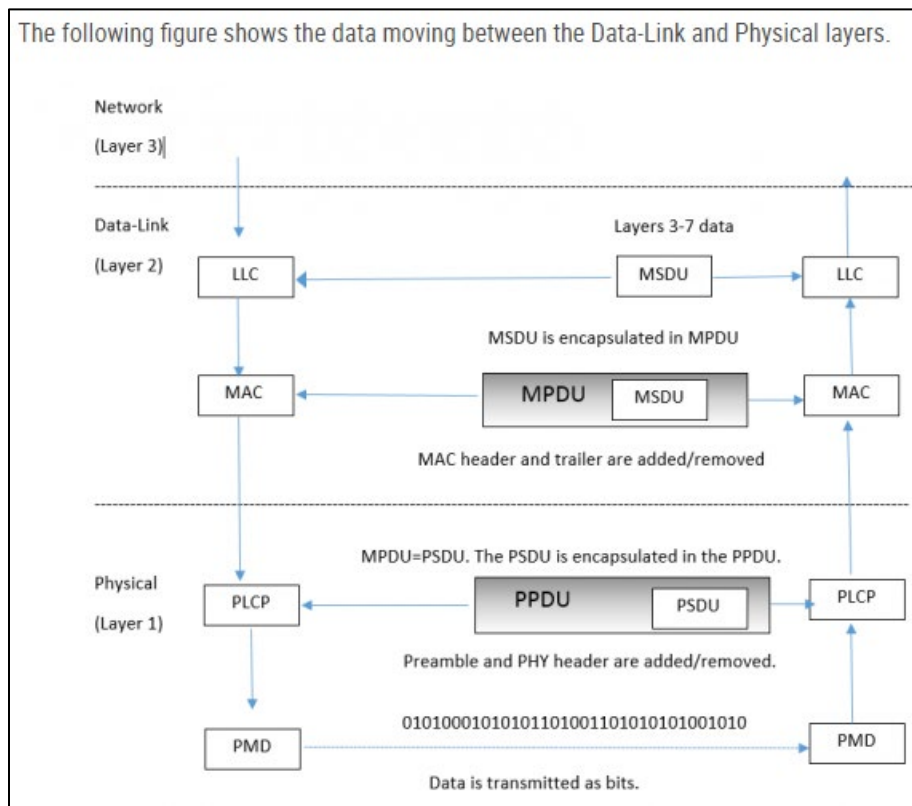

Source: <https://www.cwnp.com/802.11-mac-series-ndash-basics-mac-architecture-ndash-part-1-3/>

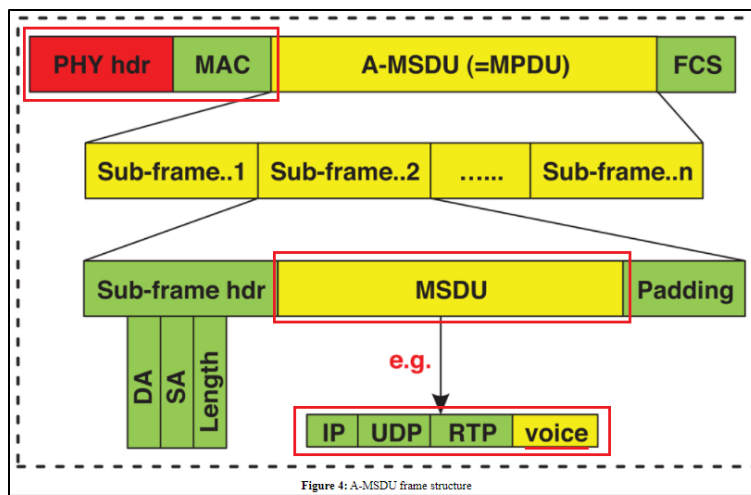

Source: <https://www.techscience.com/cmc/v66n2/40658/html>

96. The method practiced using the accused products further comprises generating a sound based on the data packet.

97. For example, a Coolpad Legacy device supports Wi-Fi calling/Voice over Wi-Fi (VoWi-Fi). As one example, when a user (caller) establishes a call using the VoWi-Fi feature with another user (the receiver), the receiver receives transmitted PPDU's from a caller via a Wi-Fi network. These PPDU's are then decapsulated to extract an IP packet ("data packet"), which includes the packetized voice data from the caller. The extracted IP packet is processed to convert the digital voice data into an analog voice signal using a codec. The analog voice signal is then fed to a speaker of the receiver's device for generating sound corresponding to the voice data extracted from the IP packet.

**coolpad Legacy™** FEATURES GALLERY TECH SPECS BUY NOW

**TECH SPECS** MORE PRODUCT DETAILS

- Design**  
Size: 6.53" x 3.17" x .33"  
Weight: 5.99 oz.  
Color: Quicksilver
- Display**  
Display Size: 6.36" FHD+  
Screen resolution: 2160 x 1080p  
Aspect ratio: 18:9  
Protection: Gorilla® Glass 3
- Battery**  
4,000mAh Battery  
Talk Time: Up to 42.6 Hours  
Standby Time: Up to 585 Hours  
Usage Time: Up to 5.3 Hours LTE  
Charging Time (Full): 2.5 Hours  
USB Type: Type C
- Features & OS**  
Qualcomm SDM450  
1.8 GHz Octa Core  
Android 9 Pie
- Memory**  
Memory: 32GB ROM/3GB RAM  
Available User Memory: 21GB  
MicroSD Support: Up to 128GB
- Connectivity**  
2G GSM: 850/900/1800/1900  
3G WCDMA: B2/4/5  
4G LTE: B2/4/5/12/66/71  
VoLTE Capable: Yes  
Wi-Fi Calling Capable: Yes  
Wi-Fi: 802.11 a/b/g/n/ac

Source: <https://coolpad.us/legacy/>

**What is VoWiFi?**

Voice over Wi-Fi (VoWiFi), as the name implies, is delivering voice service via WiFi network. Users can make calls without the need of mobile signal. VoWiFi is a complementary technology to Voice over LTE (VoLTE). Both make use of the IP Multimedia Subsystem (IMS) technology to realize the voice traffic as IP packets.

Source: <https://insinuator.net/2016/10/a-journey-into-the-depths-of-vowifi-security/>

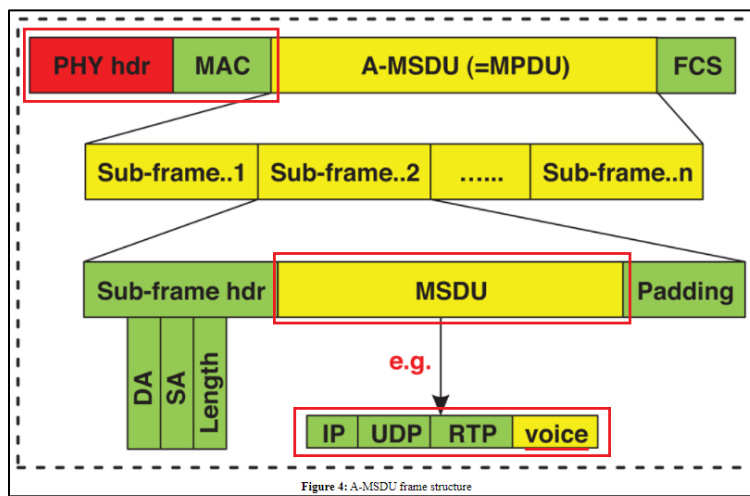

Source: <https://www.techscience.com/cmc/v66n2/40658/html>

Baseband part in a mobile is comprised of a digital signal processor (DSP) to process forward voice/data signals for transmission and to process reverse voice/data signals received.

This is the core processing part which changes for various air interface standards like GSM, HSPA, LTE and more. It is often named as physical layer or Layer 1 or L1. For Speech/audio, codec is used to compress and decompress the signal to match the data rate to the frame it has to fit in. The baseband or physical layer will add redundant bits to enable error detection as well as error correction. Error detection is obtained with CRC and error correction with forward error correction techniques. Other than this interleaving is done for the data of one burst which helps in spreading the error over the time hence helps receiver de-interleave and decode the frame (consecutively data burst) correctly.

**Source:** <https://insinuator.net/2016/10/a-journey-into-the-depths-of-vowifi-security/>

One common application for CODECs is with Digital Signal Processors (DSPs) in audio electronics devices. CODECs convert sound (using the ADC) to digital signals for a processor to compress and store and for playback, the stored digital data is decompressed and converted to analog signals via the DAC. The analog signal reaches the human ear by converting the analog signal into a transmissible sound via a pulse width modulator and a speaker, for example.

**Source:** <https://www.analogictips.com/what-is-a-codec/>

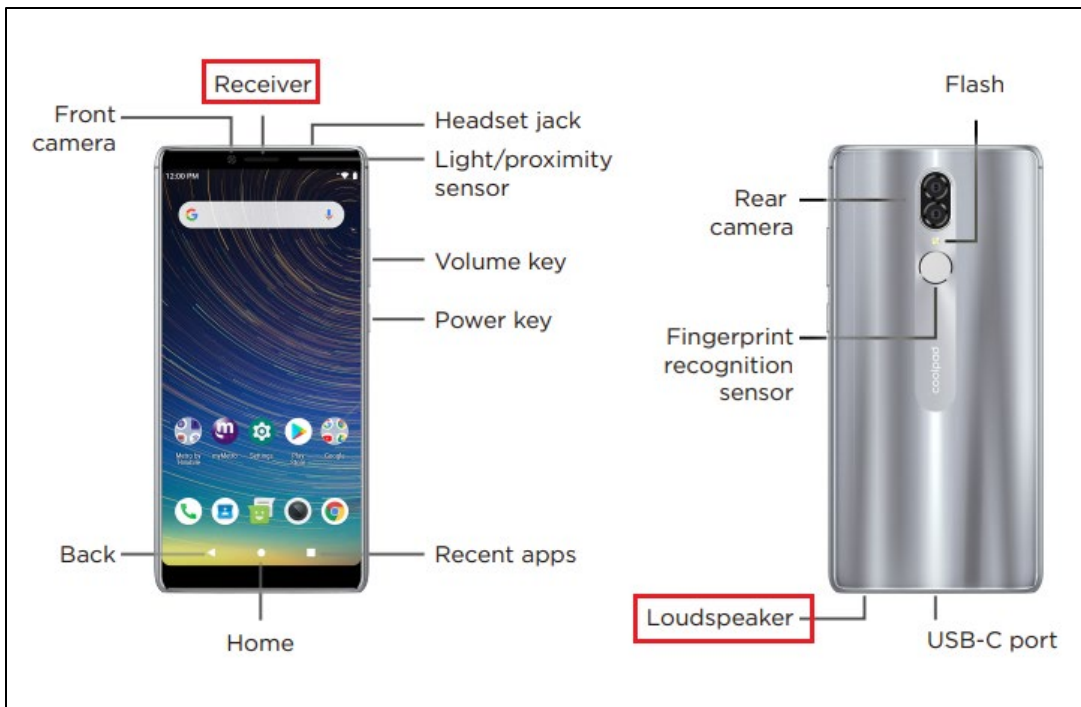

**Source:**

[https://coolpadsupport.zendesk.com/hc/article\\_attachments/360034048814/Coolpad\\_Legacy\\_OS\\_G\\_English\\_Spanish.pdf](https://coolpadsupport.zendesk.com/hc/article_attachments/360034048814/Coolpad_Legacy_OS_G_English_Spanish.pdf) (Page 1)

98. Buffalo Patents has been damaged as a result of the infringing conduct by Coolpad alleged above. Thus, Coolpad is liable to Buffalo Patents in an amount that adequately compensates it for such infringements, which, by law, cannot be less than a reasonable royalty, together with interest and costs as fixed by this Court under 35 U.S.C. § 284.

99. Buffalo Patents is only asserting method claims for the '328 Patent, and therefore, 35 U.S.C § 287(a) does not apply.

**ADDITIONAL ALLEGATIONS REGARDING INFRINGEMENT AND PERSONAL JURISDICTION**

100. Coolpad has also indirectly infringed the '670 Patent by inducing others to directly infringe the '670 Patent.



101. Coolpad has induced the end users and/or Coolpad's customers to directly infringe (literally and/or under the doctrine of equivalents) the '670 Patent by using the accused products.

102. Coolpad took active steps, directly and/or through contractual relationships with others, with the specific intent to cause them to use the accused products in a manner that infringes one or more claims of the '670 Patent, including, for example, Claim 1 of the '670 Patent.

103. Such steps by Coolpad included, among other things, advising or directing customers, end users, and others (including third party testing and certification organizations) to use the accused products in an infringing manner; advertising and promoting the use of the accused products in an infringing manner; and/or distributing instructions that guide users to use the accused products in an infringing manner.

104. Coolpad performed these steps, which constitute joint and/or induced infringement, with the knowledge of the '670 Patent and with the knowledge that the induced acts constitute infringement.

105. Coolpad was and is aware that the normal and customary use of the accused products by Coolpad's customers would infringe the '670 Patent. Coolpad's inducement is ongoing.

106. Coolpad has also induced its affiliates, or third-party manufacturers, shippers, distributors, retailers, or other persons acting on its or its affiliates' behalf, to directly infringe (literally and/or under the doctrine of equivalents) the '670 Patent by importing, selling or offering to sell the accused products.

107. Coolpad has a significant role in placing the accused products in the stream of commerce with the expectation and knowledge that they will be purchased by consumers in Texas and elsewhere in the United States.

108. Coolpad purposefully directs or controls the making of accused products and their shipment to the United States, using established distribution channels, for sale in Texas and elsewhere within the United States.

109. Coolpad purposefully directs or controls the sale of the accused products into established United States distribution channels, including sales to nationwide retailers. Coolpad's established United States distribution channels include one or more United States based affiliates (e.g., Coolpad Technologies Inc.).

110. Coolpad purposefully directs or controls the sale of the accused products online and in nationwide retailers such as Boost Mobile, including for sale in Texas and elsewhere in the United States, and expects and intends that the accused products will be so sold.

111. Coolpad purposefully places the accused products—whether by itself or through subsidiaries, affiliates, or third parties—into an international supply chain, knowing that the accused products will be sold in the United States, including Texas. Therefore, Coolpad also facilitates the sale of the accused products in Texas.

112. Coolpad took active steps, directly and/or through contractual relationships with others, with the specific intent to cause such persons to import, sell, or offer to sell the accused products in a manner that infringes one or more claims of the '670 Patent.

113. Such steps by Coolpad included, among other things, making or selling the accused products outside of the United States for importation into or sale in the United States, or knowing that such importation or sale would occur; and directing, facilitating, or influencing its

affiliates, or third-party manufacturers, shippers, distributors, retailers, or other persons acting on its or its affiliates' behalf, to import, sell, or offer to sell the accused products in an infringing manner.

114. Coolpad performed these steps, which constitute induced infringement, with the knowledge of the '670 Patent, and with the knowledge that the induced acts would constitute infringement.

115. Coolpad performed such steps in order to profit from the eventual sale of the accused products in the United States.

116. Coolpad's inducement is ongoing.

117. Coolpad has also indirectly infringed by contributing to the infringement of the '670 Patent. Coolpad has contributed to the direct infringement of the '670 Patent by the end user of the accused products.

118. The accused products have special features that are specially designed to be used in an infringing way and that have no substantial uses other than ones that infringe the '670 Patent, including, for example, Claim 1 of the '670 Patent.

119. The special features include, for example, improved wireless communication capabilities used in a manner that infringes the '670 Patent.

120. These special features constitute a material part of the invention of one or more of the claims of the '670 Patent, and are not staple articles of commerce suitable for substantial non-infringing use.

121. Coolpad's contributory infringement is ongoing.

122. Coolpad has had actual knowledge of the '670 Patent at least as of the date when it was notified of the filing of this action. Since at least that time, Coolpad has known the scope

of the claims of the '670 Patent, the products that practice the '670 Patent, and that Buffalo Patents is the owner of the '670 Patent.

123. By the time of trial, Coolpad will have known and intended (since receiving such notice) that its continued actions would infringe and actively induce and contribute to the infringement of one or more claims of the '670 Patent.

124. Furthermore, Coolpad has a policy or practice of not reviewing the patents of others (including instructing its employees to not review the patents of others), and thus has been willfully blind of Buffalo Patents' patent rights. *See, e.g.*, M. Lemley, "Ignoring Patents," 2008 Mich. St. L. Rev. 19 (2008).

125. Coolpad's actions are at least objectively reckless as to the risk of infringing valid patents, and this objective risk was either known or should have been known by Coolpad. Coolpad has knowledge of the '670 Patent.

126. Coolpad's customers have infringed the '670 Patent. Coolpad encouraged its customers' infringement.

127. Coolpad's direct and indirect infringement of the '670 Patent, and its direct infringement of the '915 Patent, the '328 Patent, and the '816 Patent has been, and/or continues to be willful, intentional, deliberate, and/or in conscious disregard of Buffalo Patents' rights under the patents-in-suit.

128. Buffalo Patents has been damaged as a result of Coolpad's infringing conduct alleged above. Thus, Coolpad is liable to Buffalo Patents in an amount that adequately compensates it for such infringements, which, by law, cannot be less than a reasonable royalty, together with interest and costs as fixed by this Court under 35 U.S.C. § 284.

**JURY DEMAND**

Buffalo Patents hereby requests a trial by jury on all issues so triable by right.

**PRAYER FOR RELIEF**

Buffalo Patents requests that the Court find in its favor and against Coolpad, and that the Court grant Buffalo Patents the following relief:

a. Judgment that one or more claims of the '670 Patent, the '915 Patent, the '328 Patent, and the '816 Patent have been infringed, either literally and/or under the doctrine of equivalents, by Coolpad and/or all others acting in concert therewith;

b. A permanent injunction enjoining Coolpad and its officers, directors, agents, servants, affiliates, employees, divisions, branches, subsidiaries, parents, and all others acting in concert therewith from infringement of the '670 Patent; or, in the alternative, an award of a reasonable ongoing royalty for future infringement of the '670 Patent by such entities;

c. Judgment that Coolpad account for and pay to Buffalo Patents all damages to and costs incurred by Buffalo Patents because of Coolpad's infringing activities and other conduct complained of herein, including an award of all increased damages to which Buffalo Patents is entitled under 35 U.S.C. § 284;

d. That Buffalo Patents be granted pre-judgment and post-judgment interest on the damages caused by Coolpad's infringing activities and other conduct complained of herein;

e. That this Court declare this an exceptional case and award Buffalo Patents its reasonable attorney's fees and costs in accordance with 35 U.S.C. § 285; and

f. That Buffalo Patents be granted such other and further relief as the Court may deem just and proper under the circumstances.

Dated: October 13, 2021

Respectfully submitted,

/s/ Zachariah S. Harrington  
Matthew J. Antonelli  
Texas Bar No. 24068432

matt@ahtlawfirm.com  
Zachariah S. Harrington  
Texas Bar No. 24057886  
zac@ahtlawfirm.com  
Larry D. Thompson, Jr.  
Texas Bar No. 24051428  
larry@ahtlawfirm.com  
Christopher Ryan Pinckney  
Texas Bar No. 24067819  
ryan@ahtlawfirm.com  
Rehan M. Safiullah  
Texas Bar No. 24066017  
rehan@ahtlawfirm.com

ANTONELLI, HARRINGTON  
& THOMPSON LLP  
4306 Yoakum Blvd., Ste. 450  
Houston, TX 77006  
(713) 581-3000

*Attorneys for Buffalo Patents, LLC*